

## MICRO SWITCH™ Environmentally Sealed Limit Switches

EN Series

003125

Issue 1

Datasheet



### DESCRIPTION

The Honeywell MICRO SWITCH™ Series of EN limit switches are bushing mount designed, manufactured, and qualified to MIL-PRF-8805 standards. These products provide a durable switch for commercial and military aircraft as well as commercial and military ground-based equipment. Other applications include off-road equipment where severe environments are encountered.

The EN Series of switches have proven to deliver consistent and reliable operation in harsh environments on critical applications for more than 65 years.

### VALUE TO CUSTOMERS

- Precise and reliable position indication of critical applications on aircraft and military systems

### DIFFERENTIATION

- MICRO SWITCH™ EN Series' products are highly configurable; offering a variety of integral actuators, electrical circuitries, and electrical terminations

### FEATURES

- Circuitry options from 1PST (one-pole single throw) circuit to 6PDT (six-pole double throw) circuits for position indication of different independent circuits or providing redundant circuit capabilities
- Rugged stainless steel housing and bushing
- All-metal drive train for consistent operating characteristics at high or low temperatures
- Most EN catalog listings are MIL-PRF-8805 compliant for stringent military and non-military applications
- MIL-PRF-8805 symbol 4 (resilient) sealing to keep dust, water, and ice from entering the switch enclosure
- Gold-bifurcated, gold-plated, or silver-alloy switch contacts for reliably controlling electrical loads from less than 0.5 A [low energy/logic level] up to 15 A (power duty)
- Wide temperature range from -54 °C to 125 °C [-65 °F to 257 °F] for sea level or high altitude military or commercial applications
- Assortment of switch actuators and electrical terminations
- Miniature package size [400EN Series and 600EN Series] reduces housing diameter by 30 % for smaller space required on equipment

### POTENTIAL APPLICATIONS

- Landing gear systems for commercial and military aircraft including helicopters
  - WOW switch (Weight-on-Wheels) for landing gear
  - Up-lock and down-lock sensing
  - Landing gear bay doors closed/locked
- External doors and hatches for commercial and military aircraft including helicopters
  - Closed and locked indication for passenger entry/exit doors, cargo bay doors, and/or other doors or hatches (refueling door, APU air inlet door)
- Military ground vehicles
  - Doors or hatches closed/locked or open
- Off-road construction equipment
  - Doors or panels present/closed/open
  - Up-stop or down-stop limits

### PORTFOLIO

Honeywell offers many Series of MICRO SWITCH™ sealed switches including the [HM Series](#), [SE Series](#), [XE Series](#), [HS Series](#), [HE Series](#), and [HR Series](#).

# MICRO SWITCH™ Environmentally Sealed Limit Switches, EN Series

Table 1. Specifications

Characteristic	Parameter
Description	Environmentally sealed military qualified limit switch series (MIL-PRF-8805)
Housing & bushing material	300 Series stainless steel
Contact material	Silver alloy, gold plated, gold bifurcated
Mechanical endurance	25,000 cycles min.
Electrical endurance	25,000 cycles min. @ rated load
Circuitry	1PST (one-pole single throw) to 6PDT (six-pole double throw); reference Figure 2, page 3
Electrical rating	Up to 15 A @ 28 Vdc; reference Table 2, page 2
Dielectric strength (initial)	1000 V RMS; 500 $\mu$ A max. leakage
Insulation resistance (initial)	500 Vdc; 1000 Megohms min.
Environmental sealing	Symbol 4, resilient seal per MIL-PRF-8805
Temperature range (std.)	-54 °C to 85 °C [-65 °F to 185 °F]
Temperature range (opt.)	-54 °C to 125 °C [-65 °F to 257 °F]
Shock	Symbol M (100 g) per MIL-PRF-8805
Vibration	Symbol 1, 10 g peak (10 Hz to 500 Hz)
Standards	Design conforms to MIL-PRF-8805

Table 2. Electrical Ratings

Rating Code	Sea Level @ 28 Vdc				Altitude 50,000 ft			
	Inrush	Motor	Res.	Ind.	Inrush	Motor <sup>2</sup>	Res.	Ind.
A	24	4	4	2	24	4	4 <sup>1</sup>	2
B	36	6	10	3	36	6	10	3
C	30	5	15	10	30	5	15	10
D	24	4	5	3	-			
E	-		1	0.5	-		1	0.5
F	N/A	4	7	4	N/A	4	7	2.5

<sup>1</sup> 5 A for rotary switches.

<sup>2</sup> Application information only.

# MICRO SWITCH™ Environmentally Sealed Limit Switches, EN Series

## STANDARD SWITCHES *(see pages 4 and 5)*

While the standard EN Series provides a wide variety of products, Honeywell offers a miniature EN Series and a special EN Series per the following descriptions.

## MINIATURE SWITCHES *(see pages 6 through 8)*

Miniature type EN switches meet the demand for smaller size and lighter weight without sacrificing performance or electrical capacity. These types are of the same construction, seal, and materials as the standard size EN switches.

Type 400EN switches are directly interchangeable with their standard size EN counterpart, yet the housings are smaller in diameter and lighter in weight. The miniature-size housing is 7,92 mm [0.312 in] smaller in diameter, and the switch weighs 9,1 g [0.3 oz] less.

## SWITCHES WITH SPECIAL REQUIREMENTS

*(see page 9)*

### High velocity actuation

This switch (1EN231-6) is designed to withstand near “hammer-blow” actuation as is found in over-center locking mechanisms. It is dimensionally interchangeable with standard listing 1EN1-6.

### Low force operation

Special spring construction within this switch (1EN51-6) reduces the normal 6 lb to 12 lb (26,7 N to 53,4 N) EN operating force to 3 lb to 6 lb (13,3 N to 26,7 N). This switch is also dimensionally interchangeable with the standard size 1EN1-6.

### Increased overtravel

A longer plunger and bushing on the switch (1EN61-6) extends the EN overtravel capabilities from the normal 6,35 mm to 21,8 mm [0.25 in to 0.86 in]. The longer bushing also permits additional adjustment of the plunger position or installations where an increased bushing length is required.

### High impact shock

Catalog listing, 1EN75-R3 (M8805/65-001), has been qualified to MIL-PRF-8805, including high impact shock class H. Other switches rated for high impact shock applications incorporate the same plunger mechanism and internal switch design as used in the 1EN75-R3 and are expected to conform to the same requirements.

## TERMINATION

Termination is specified in the order guides. Leadwires are generally six feet long, and of the gage and military specifications noted in the order guides.

## MOUNTING

Plunger actuator switches mount through 5/8 in [Ø 0.625 in] or 15/32 in [Ø 0.469 in] holes. Lock washer, keyed washer, and wire lock hexagon mounting nuts lock the switches in their mounting holes.

Rotary-actuated switches mount through 15/32 in [Ø 0.469 in] holes. A lock washer, wire lock hexagon nut, and locating pins on the top of the housing prevent switch rotation.

Figure 1. Typical EN Switch Construction

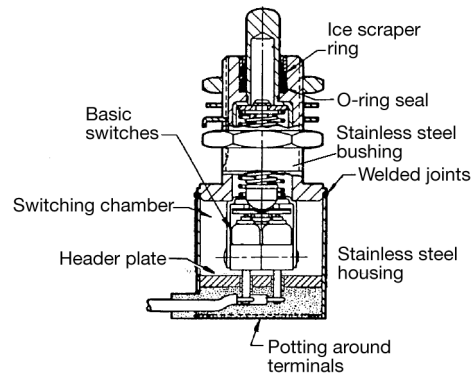
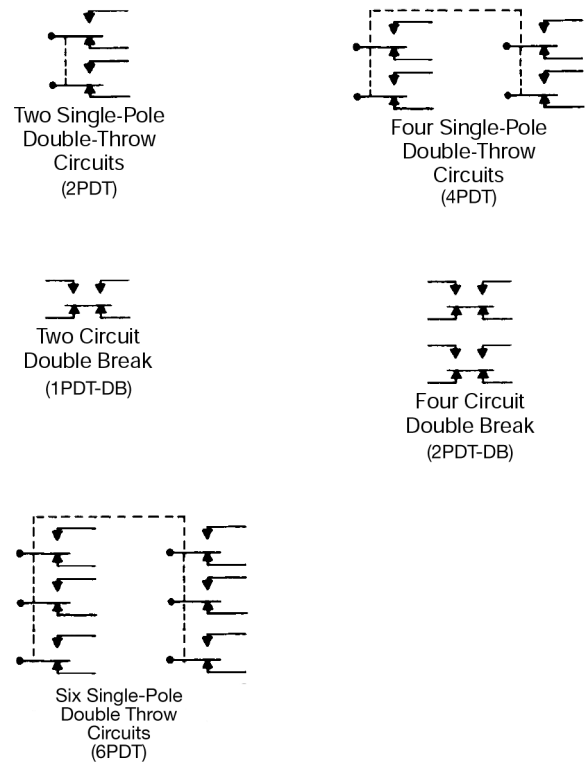

Figure 2. Circuitry Diagrams



# MICRO SWITCH™ Environmentally Sealed Limit Switches, EN Series

Table 3. EN Series Order Guide - Standard Series

Actuator	Circuitry	Termination	Electrical Rating Code**	Catalog Listing	Military Number or Note	O.F. N [lb]	R.F. min. N [lb]	F.P. nom. mm [in]	P.T. max. mm [in]	O.T. min. mm [in]	D.T. max. mm [in]	Bushing Thread Size	Housing Height mm [in]	Housing Diameter or Length mm [in]	Replacement Mounting Hardware Packet
PIN PLUNGER	2PDT	Leadwire #20 AWG (side exit) MIL-DTL-22759/7	A [4 A]	<b>1EN1-6</b>	<b>MS24331-1 (8805/40)</b>	26,7 to 53,4 [6 to 12]	17,8 [4]	35,0 [1.38]	1,02 [0.040]	6,35 [0.250]	0,51 [0.020]	0.625-24 UNEF	24,9 [0.980]	Ø 25,4 [1.0]	19PA8
	2PDT	Screw (4-48 thread)	A [4 A]	<b>1EN1-S</b>	–	26,7 to 53,4 [6 to 12]	17,8 [4]	35,0 [1.38]	1,02 [0.040]	6,35 [0.250]	0,51 [0.020]	0.625-24 UNEF	38,2 [1.51]	Ø 25,4 [1.0]	19PA78-EN
	2PDT	Connector (side exit)	A [4 A]	<b>1EN42-R</b>	–	26,7 to 53,4 [6 to 12]	17,8 [4]	35,0 [1.38]	1,02 [0.040]	6,35 [0.250]	0,51 [0.020]	0.625-24 UNEF	27,9 [1.10]	61,0 [2.4]	19PA78-EN
	2PDT	Connector (bottom exit)	A [4 A]	<b>1EN43-R</b>	–	26,7 to 53,4 [6 to 12]	17,8 [4]	35,0 [1.38]	1,02 [0.040]	6,35 [0.250]	0,51 [0.020]	0.625-24 UNEF	53,3 [2.1]	Ø 25,4 [1.0]	19PA78-EN
	2PDT	Leadwire #18 AWG (side exit) MIL-DTL-22759/7	B [10 A]	<b>2EN1-6</b>	<b>MS24331-2 (8805/40)</b>	26,7 to 53,4 [6 to 12]	22,3 [5]	35,0 [1.38]	1,27 [0.050]	6,35 [0.250]	0,89 [0.035]	0.625-24 UNEF	38,1 [1.50]	Ø 38,1 [1.50]	19PA8
	1PDT-DB	Leadwire #18 AWG (side exit) MIL-DTL-22759/7	C [15 A]	<b>3EN1-6</b>	<b>MS24331-3 (8805/40)</b>	26,7 to 53,4 [6 to 12]	22,3 [5]	35,0 [1.38]	1,52 [0.060]	6,35 [0.250]	0,89 [0.035]	0.625-24 UNEF	33,3 [1.31]	Ø 38,1 [1.50]	19PA8
	2PDT-DB	Leadwire #18 AWG (side exit) MIL-DTL-22759/7	C [15 A]	<b>4EN1-6</b>	<b>MS24331-4 (8805/40)</b>	26,7 to 53,4 [6 to 12]	22,3 [5]	35,0 [1.38]	1,78 [0.070]	6,35 [0.250]	1,14 [0.045]	0.625-24 UNEF	43,2 [1.70]	Ø 38,1 [1.50]	19PA8
	4PDT	Leadwire #20 AWG (side exit) MIL-DTL-22759/7	A [4 A]	<b>5EN1-6</b>	–	26,7 to 53,4 [6 to 12]	17,8 [4]	35,0 [1.38]	1,02 [0.040]	6,35 [0.250]	0,76 [0.030]	0.625-24 UNEF	30,5 [1.20]	Ø 38,1 [1.50]	19PA78-EN
BALL BEARING PLUNGER	2PDT	Leadwire #20 AWG (side exit) MIL-DTL-22759/7	A [4 A]	<b>2001EN1-6</b>	–	26,7 to 53,4 [6 to 12]	17,8 [4]	39,1 [1.54]	1,02 [0.040]	6,35 [0.250]	0,51 [0.020]	0.625-24 UNEF	24,9 [0.980]	Ø 25,4 [1.0]	19PA8
ROLLER PLUNGER*	2PDT	Leadwire #20 AWG (side exit) MIL-DTL-22759/7	A [4 A]	<b>21EN9-6*</b>	FAA-PMA	26,7 to 53,4 [6 to 12]	17,8 [4]	45,2 [1.78]	1,02 [0.040]	6,35 [0.250]	0,51 [0.020]	0.625-24 UNEF	24,9 [0.980]	Ø 25,4 [1.0]	19PA115-EN
	2PDT	Leadwire #18 AWG (side exit) MIL-W-22759/7	B [10 A]	<b>22EN9-6*</b>	–	26,7 to 53,4 [6 to 12]	22,3 [5]	45,2 [1.78]	1,27 [0.050]	6,35 [0.250]	0,89 [0.035]	0.625-24 UNEF	38,1 [1.5]	Ø 38,1 [1.5]	19PA115-EN
	2PDT-DB	Leadwire #18 AWG (side exit) MIL-W-22759/7	C [15 A]	<b>24EN9-6*</b>	–	26,7 to 53,4 [6 to 12]	22,3 [5]	45,2 [1.78]	1,78 [0.070]	6,35 [0.250]	1,14 [0.045]	0.625-24 UNEF	43,2 [1.70]	Ø 38,1 [1.50]	19PA115-EN
	4PDT	Leadwire #20 AWG (side exit) MIL-W-22759/7	A [4 A]	<b>25EN9-6*</b>	FAA-PMA	26,7 to 53,4 [6 to 12]	17,8 [4]	45,2 [1.78]	1,02 [0.040]	6,35 [0.250]	0,76 [0.030]	0.625-24 UNEF	30,5 [1.20]	Ø 38,1 [1.50]	19PA115-EN

O.F.- Operating Force; R.F.- Release Force; F.P.-Free Position; P.T.-Pretravel; O.T.-Overtravel; D.T.-Differential Travel

\* Roller plunger field adjustable in 45° increments.

\*\* Reference Table 2, page 2, for additional detail.

# MICRO SWITCH™ Environmentally Sealed Limit Switches, EN Series

Table 3. EN Series Order Guide - Standard Series, continued

Actuator	Circuitry	Termination	Electrical Rating Code**	Catalog Listing	Military Number or Note	O.T. Nm [in-lb]	R.T. min. Nm [in-lb]	P.T. degrees [nom.]	T.T. degrees [nom.]	D.T. max. degrees	Bushing Thread Size	Housing Height mm [in]	Housing Diameter or Length mm [in]	Replacement Mounting Hardware Packet
ROTARY ROLLER LEVER	2PDT	Leadwire #20 AWG (side exit) MIL-W-22759/7	D [5 A]	<b>31EN11-6 (CW)</b>	<b>MS21320-1 (8805/48)</b>	1,36 to 2,82 [12 to 25]	1,02 [9]	13°	45°	4°	0.469-32 UNS	54,8 [2.16]	Ø 25,4 [1.0]	19PA10
	2PDT	Leadwire #20 AWG (side exit) MIL-W-22759/7	D [5 A]	<b>31EN1-6 (CCW)</b>	<b>MS21320-2 (8805/48)</b>	1,36 to 2,82 [12 to 25]	1,02 [9]	13°	45°	4°	0.469-32 UNS	54,8 [2.16]	Ø 25,4 [1.0]	19PA10
	2PDT	Leadwire #18 AWG (side exit) MIL-W-22759/7	B [10 A]	<b>32EN11-6 (CW)</b>	<b>MS21320-3 (8805/48)</b>	1,36 to 2,82 [12 to 25]	1,02 [9]	20°	45°	6°	0.469-32 UNS	68,6 [2.70]	Ø 38,1 [1.5]	19PA10
	2PDT	Leadwire #18 AWG (side exit) MIL-W-22759/7	B [10 A]	<b>32EN1-6 (CCW)</b>	<b>MS21320-4 (8805/48)</b>	1,36 to 2,82 [12 to 25]	1,02 [9]	20°	45°	6°	0.469-32 UNS	68,6 [2.70]	Ø 38,1 [1.5]	19PA10
	2PDT-DB	Leadwire #18 AWG (side exit) MIL-W-22759/7	C [15 A]	<b>34EN11-6 (CW)</b>	<b>MS21320-7 (8805/48)</b>	1,36 to 2,82 [12 to 25]	0,9 [8]	15°	45°	10°	0.469-32 UNS	71,6 [2.82]	Ø 38,1 [1.5]	19PA10
	2PDT-DB	Leadwire #18 AWG (side exit) MIL-W-22759/7	C [15 A]	<b>34EN1-6 (CCW)</b>	<b>MS21320-8 (8805/48)</b>	1,36 to 2,82 [12 to 25]	0,9 [8]	15°	45°	10°	0.469-32 UNS	71,6 [2.82]	Ø 38,1 [1.5]	19PA10
	2PDT	Leadwire #18 AWG (side exit) MIL-W-22759/7	E [1 A]	<b>35EN27-4 (CW)</b>	Gold-bifurcated contacts	1,36 to 2,82 [12 to 25]	1,02 [9]	20°	45°	6°	0.469-32 UNS	60,7 [2.39]	Ø 38,1 [1.5]	19PA10
	2PDT	Leadwire #18 AWG (side exit) MIL-W-22759/7	E [1 A]	<b>35EN24-4 (CCW)</b>	FAA-PMA, Gold-bifurcated contacts	1,36 to 2,82 [12 to 25]	1,02 [9]	20°	45°	6°	0.469-32 UNS	60,7 [2.39]	Ø 38,1 [1.5]	19PA10
ROTARY LINKAGE LEVER <sup>1</sup>	2PDT	Leadwire #20 AWG (side exit) MIL-W-22759/7	A [4 A]	<b>41EN1-6<sup>1</sup></b>	<b>MS24420-1</b>	0,34 [3]	-	Nom. 35° actuation in 360° rotation		12°	0.469-32 UNS	26,7 [1.05]	Ø 25,4 [1.0]	19PA10
	2PDT	Leadwire #18 AWG (side exit) MIL-W-22759/7	B [10 A]	<b>42EN1-6<sup>1</sup></b>	<b>MS24420-2</b>	0,56 [5]	-	Nom. 35° actuation in 360° rotation		12°	0.469-32 UNS	42,7 [1.68]	Ø 38,1 [1.5]	19PA10
	2PDT-DB	Leadwire #18 AWG (side exit) MIL-W-22759/7	C [15 A]	<b>44EN1-6<sup>1</sup></b>	<b>MS24420-4</b>	1,13 [10]	-	Nom. 35° actuation in 360° rotation		20°	0.469-32 UNS	46,2 [1.82]	Ø 38,1 [1.5]	19PA10

O.T.- Operating Torque; R.T.- Release Torque; P.T.-Pretravel; T.T.-Total Travel; D.T.-Differential Travel

<sup>1</sup> These rotary linkage lever switches are continuous rotation CW or CCW.

\*\* Reference Table 2, page 2, for additional detail.

# MICRO SWITCH™ Environmentally Sealed Limit Switches, EN Series

Table 4. EN Series Order Guide - Miniature Series

Actuator	Circuitry	Termination	Electrical Rating Code**	Catalog Listing	Military Number or note	O.F. N [lb]	R.F. min. N [lb]	F.P. nom. mm [in]	P.T. max. mm [in]	O.T. min. mm [in]	D.T. max. mm [in]	Bushing Thread Size	Housing Height mm [in]	Housing Diameter or Length mm [in]	Replacement Mounting Hardware Packet
PIN PLUNGER	2PDT	Leadwire #20 AWG (side exit) MIL-W-22759/7	F [7 A]	402EN1-6	MS21321-1 8805/39	26,7 to 53,4 [6 to 12]	17,8 [4]	35,0 [1.38]	1,02 [0.040]	6,35 [0.250]	0,51 [0.020]	0.625-24 UNEF	24,9 [0.98]	Ø 17,5 [0.69]	-
	4PDT	Leadwire #20 AWG (side exit) MIL-W-22759/7	F [7 A]	404EN1-6	MS21321-2 8805/39	26,7 to 53,4 [6 to 12]	17,8 [4]	35,0 [1.38]	1,02 [0.040]	6,35 [0.250]	0,51 [0.020]	0.625-24 UNEF	30,5 [1.2]	Ø 25,4 [1.0]	-
	2PDT	Leadwire #20 AWG (side exit) MIL-W-22759/7	F [7 A]	602EN1-6	MS27240-1 8805/43	26,7 to 53,4 [6 to 12]	17,8 [4]	22,3 [0.88]	1,02 [0.040]	3,18 [0.125]	0,51 [0.020]	0.469-32 UNS	25,4 [1.0]	Ø 17,5 [0.69]	19PA9
	2PDT	Solder pins	F [7 A]	602EN142	-	26,7 to 53,4 [6 to 12]	17,8 [4]	22,3 [0.88]	1,02 [0.040]	3,18 [0.125]	0,51 [0.020]	0.469-32 UNS	25,4 [1.0]	Ø 17,5 [0.69]	19PA9
	2PDT	Leadwire #20 AWG (side exit) MIL-W-22759/7	E [1 A]	602EN222-6*	MS27240-5 8805/43, Gold-plated contacts	26,7 to 53,4 [6 to 12]	17,8 [4]	22,3 [0.88]	1,02 [0.040]	3,18 [0.125]	0,51 [0.020]	0.469-32 UNS	25,4 [1.0]	Ø 17,5 [0.69]	19PA9
	2PDT	Leadwire #20 AWG (side exit) MIL-W-22759/7	F [7 A]	602EN602-6	FAA-PMA	8,9 to 17,8 [2 to 4]	4,7 [1]	37,1 [1.46]	nom. 0,38 [0.015]	6,35 [0.250]	0,51 [0.020]	0.469-32 UNS	25,4 [1.0]	Ø 17,5 [0.69]	19PA9
	4PDT	Leadwire #20 AWG (side exit) MIL-W-22759/7	F [7 A]	604EN1-6	MS27240-2 8805/43	26,7 to 53,4 [6 to 12]	17,8 [4]	22,3 [0.88]	1,02 [0.040]	3,18 [0.125]	0,51 [0.020]	0.469-32 UNS	30,5 [1.2]	Ø 25,4 [1.0]	19PA9
	4PDT	Leadwire #20 AWG (side exit) MIL-W-22759/7	E [1 A]	604EN222-6*	MS27240-6 8805/43, Gold-plated contacts	26,7 to 53,4 [6 to 12]	17,8 [4]	22,3 [0.88]	1,02 [0.040]	3,18 [0.125]	0,51 [0.020]	0.469-32 UNS	30,5 [1.2]	Ø 25,4 [1.0]	19PA9

O.F.- Operating Force; R.F.- Release Force; F.P.-Free Position; P.T.-Pretravel; O.T.-Overtravel; D.T.-Differential Travel

\* Each pole (basic switch) has gold-plated silver contacts for controlling low energy loads. If the switch is applied to a power-duty application, the switch is not recommended to control a low energy load.

\*\* Reference Table 2, page 2, for additional detail.

# MICRO SWITCH™ Environmentally Sealed Limit Switches, EN Series

Table 4. EN Series Order Guide - Miniature Series, continued

Actuator	Circuitry	Termination	Electrical Rating Code**	Catalog Listing	Military Number or note	O.F. N [lb]	R.F. min. N [lb]	F.P. nom. mm [in]	P.T. max. mm [in]	O.T. min. mm [in]	D.T. max. mm [in]	Bushing Thread Size	Housing Height mm [in]	Housing Diameter or Length mm [in]	Replacement Mounting Hardware Packet
ROLLER PLUNGER*	2PDT	Leadwire #20 AWG (side exit) MIL-W-22759/7	F [7 A]	422EN1-6*	-	26,7 to 53,4 [6 to 12]	17,8 [4]	45,2 [1.78]	1,02 [0.040]	6,35 [0.250]	0,51 [0.020]	0.625-24 UNEF	24,9 [0.98]	Ø 17,5 [0.69]	19PA115-EN
	4PDT	Leadwire #20 AWG (side exit) MIL-W-22759/7	F [7 A]	424EN1-6*	-	26,7 to 53,4 [6 to 12]	17,8 [4]	45,2 [1.78]	1,02 [0.040]	6,35 [0.250]	0,51 [0.020]	0.625-24 UNEF	30,5 [1.2]	Ø 25,4 [1.0]	19PA8
	6 PDT	Leadwire #20 AWG (side exit) MIL-W-22759/7	F [7 A]	426EN9-8*	-	26,7 to 53,4 [6 to 12]	17,8 [4]	45,2 [1.78]	1,02 [0.040]	6,35 [0.250]	0,76 [0.030]	0.625-24 UNEF	32,7 [1.29]	Ø 38,1 [1.5]	19PA8
	2PDT	Leadwire #20 AWG (side exit) MIL-W-22759/7	F [7 A]	622EN1-6*	MS27240-3 8805/43	26,7 to 53,4 [6 to 12]	17,8 [4]	32,9 [1.30]	1,02 [0.040]	3,18 [0.125]	0,51 [0.020]	0.469-32 UNS	25,4 [1.0]	Ø 17,5 [0.69]	19PA9
	2PDT	Leadwire #20 AWG (side exit) MIL-W-22759/7	E [1 A]	622EN222-6* <sup>1</sup>	MS27240-7 8805/43, Gold-plated contacts	26,7 to 53,4 [6 to 12]	17,8 [4]	32,9 [1.30]	1,02 [0.040]	3,18 [0.125]	0,51 [0.020]	0.469-32 UNS	25,4 [1.0]	Ø 17,5 [0.69]	19PA9
	4PDT	Leadwire #20 AWG (side exit) MIL-W-22759/7	F [7 A]	624EN1-6*	MS27240-4 8805/43	26,7 to 53,4 [6 to 12]	17,8 [4]	32,9 [1.30]	1,02 [0.040]	3,18 [0.125]	0,51 [0.020]	0.469-32 UNS	30,5 [1.2]	Ø 25,4 [1.0]	19PA9
	4PDT	Leadwire #20 AWG (side exit) MIL-W-22759/7	E [1 A]	624EN222-6* <sup>1</sup>	MS27240-8 8805/43 Gold-plated contacts	26,7 to 53,4 [6 to 12]	17,8 [4]	32,9 [1.30]	1,02 [0.040]	3,18 [0.125]	0,51 [0.020]	0.469-32 UNS	30,5 [1.2]	Ø 25,4 [1.0]	19PA9

O.F.- Operating Force; R.F.- Release Force; F.P.-Free Position; P.T.-Pretravel; O.T.-Overtravel; D.T.-Differential Travel

<sup>1</sup> Each pole (basic switch) has gold-plated silver contacts for controlling low energy loads. If the switch is applied to a power-duty application, the switch is not recommended to control a low energy load.

\* Roller plunger field adjustable in 45° increments.

\*\* Reference Table 2, page 2, for additional detail.

# MICRO SWITCH™ Environmentally Sealed Limit Switches, EN Series

Table 4. EN Series Order Guide - Miniature Series, continued

Actuator	Circuitry	Termination	Electrical Rating Code**	Catalog Listing	Military Number or note	O.T. Nm [in-lb]	R.T. min. Nm [in-lb]	P.T. degrees [nom.]	T.T. degrees [nom.]	D.T. max. degrees	Bushing Thread Size	Housing Height mm [in]	Housing Diameter or Length mm [in]	Replacement Mounting Hardware Packet
ROTARY LINKAGE LEVER <sup>1</sup>	2PDT	Leadwire #20 AWG (side exit) MIL-W-22759/7	F [7 A]	<b>442EN1-6<sup>1</sup></b>	–	0,34 [3]	–	Nom. 50° actuation in 360° rotation	–	12°	0.469-32 UNS	25,4 [1.0]	Ø 17,5 [0.69]	–
	4PDT	Leadwire #20 AWG (side exit) MIL-W-22759/7	F [7 A]	<b>444EN1-6<sup>1</sup></b>	–	0,34 [3]	–	Nom. 50° actuation in 360° rotation	–	12°	0.469-32 UNS	30,23 [1.19]	Ø 17,5 [0.69]	–
	4PDT	Leadwire #20 AWG (side exit) MIL-W-22759/7	F [7 A]	<b>444EN49-6<sup>1</sup></b>	–	0,34 [3]	–	Nom. 50° actuation in 360° rotation	–	12°	0.469-32 UNS	30,23 [1.19]	Ø 17,5 [0.69]	–
	4PDT	Leadwire #20 AWG (side exit) MIL-W-22759/7	E [1 A]	<b>444EN222-6<sup>1,2</sup></b>	Gold-plated contacts	0,34 [3]	–	Nom. 50° actuation in 360° rotation	–	12°	0.469-32 UNS	30,23 [1.19]	Ø 17,5 [0.69]	–

O.T.- Operating Torque; R.T.- Release Torque; P.T.-Pretravel; T.T.-Total Travel; D.T.-Differential Travel

<sup>1</sup> These rotary linkage lever switches are continuous rotation CW or CCW.

<sup>2</sup> Each pole (basic switch) has gold-plated silver contacts for controlling low energy loads. If the switch is applied to a power-duty application, the switch is not recommended to control a low energy load.

\*\* Reference Table 2, page 2, for additional detail.



# MICRO SWITCH™ Environmentally Sealed Limit Switches, EN Series

Table 5. EN Series Order Guide - Special Purpose Series

Utilization	Actuator	Circuitry	Termination	Electrical Rating Code **	Catalog Listing	Military Number or note	O.F. N [lb]	R.F. min. N [lb]	F.P. nom. mm [in]	P.T. max. mm [in]	O.T. min. mm [in]	D.T. max. mm [in]	Bushing Thread Size	Housing Height mm [in]	Housing Diameter or Length mm [in]	Replacement Mounting Hardware Packet	
HIGH VELOCITY ACTUATION	PIN PLUNGER	2PDT	Leadwire #20 AWG (side exit) MIL-W-22759/7	A [4 A]	<b>1EN231-6</b>	-	26,7 to 53,4 [6 to 12]	17,8 [4]	35,0 [1.38]	1,02 [0.040]	5,84 [0.230]	0,51 [0.020]	0.625-24 UNEF	24,9 [0.98]	25,4 [1.0]	19PA78-EN	
LOW FORCE OPERATION		2PDT	Leadwire #20 AWG (side exit) MIL-W-22759/7	A [4 A]	<b>1EN51-6</b>	-	13,3 to 26,7 [3 to 6]	8,89 [2]	35,0 [1.38]	1,02 [0.040]	6,35 [0.250]	0,51 [0.020]	0.625-24 UNEF	24,9 [0.98]	25,4 [1.0]	19PA78-EN	
INCREASED OVERTRAVEL		2PDT	Leadwire #20 AWG (side exit) MIL-W-81044/9 Type E	A [4 A]	<b>1EN61-6</b>	FAA-PMA		26,7 to 53,4 [6 to 12]	17,8 [4]	35,0 [1.38]	1,02 [0.040]	12,70 [0.500]	0,51 [0.020]	0.625-24 UNEF	24,9 [0.98]	25,4 [1.0]	19PA78-EN
INCREASED SHOCK RESISTANCE		2PDT	7 Pin bottom exit, MIL. type connector	A [4 A]	<b>1EN75-R</b>	-		26,7 to 53,4 [6 to 12]	17,8 [4]	9,53 [0.375]	1,02 [0.040]	6,35 [0.250]	0,51 [0.020]	1.0-20 UNEF	57,9 [2.28]	Ø 25,4 [1.0]	19PA121-EN
		2PDT	7 Pin side exit, MIL. type connector	A [4 A]	<b>1EN76-R</b>	-		26,7 to 53,4 [6 to 12]	17,8 [4]	9,53 [0.375]	1,02 [0.040]	6,35 [0.250]	0,51 [0.020]	1.0-20 UNEF	36,6 [1.44]	26,7 [1.05]	19PA121-EN
		2PDT	7 Pin bottom exit, MIL. type connector	D [5 A]	<b>1EN75-R3</b>	<b>M8805/65-001</b>		26,7 to 53,4 [6 to 12]	17,8 [4]	9,53 [0.375]	1,02 [0.040]	6,35 [0.250]	0,51 [0.020]	1.0-20 UNEF	73,4 [2.89]	Ø 25,4 [1.0]	19PA121-EN
		2PDT	7 Pin bottom exit, MIL. type connector	A [4 A]	<b>21EN75-R1*</b>	-		26,7 to 53,4 [6 to 12]	17,8 [4]	19,8 [0.78]	1,02 [0.040]	6,35 [0.250]	0,51 [0.020]	1.0-20 UNEF	57,9 [2.28]	Ø 25,4 [1.0]	19PA121-EN
	2PDT	Leadwire #20 AWG (side exit) MIL-W-22759/7	A [4 A]	<b>21EN75-2*</b>	-		26,7 to 53,4 [6 to 12]	17,8 [4]	19,8 [0.78]	1,02 [0.040]	6,35 [0.250]	0,51 [0.020]	1.0-20 UNEF	34,5 [1.36]	Ø 25,4 [1.0]	19PA121-EN	

O.F.- Operating Force; R.F.- Release Force; F.P.-Free Position; P.T.-Pretravel; O.T.-Overtravel; D.T.-Differential Travel

\*Roller plunger field adjustable in 45° increments.

\*\* Reference Table 2, page 2, for additional detail.

# MICRO SWITCH™ Environmentally Sealed Limit Switches, EN Series

## OPERATION

### Plunger Actuators

For in-line actuation. An ice scraper ring cleans the actuator with each operation.

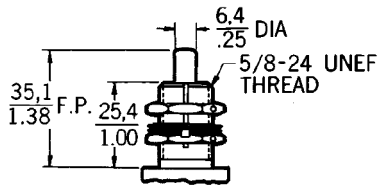

### Ball Bearing Plunger Actuators

For random direction operation. An ice scraper ring cleans the actuator with each operation.

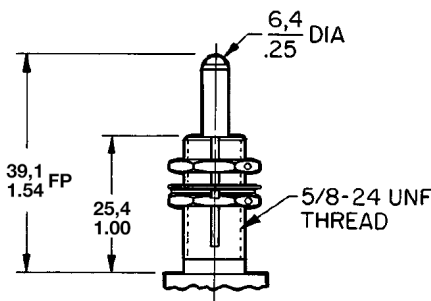

### Roller Plunger Actuators

For cam and slide actuation not to exceed 20° rise. Roller adjusts laterally in 45° increments. An ice scraper ring cleans the actuator with each operation.

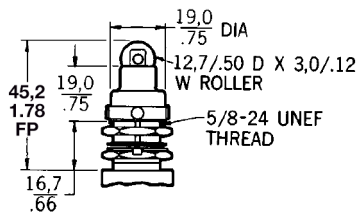

### Roller Linkage Lever Actuators

A threaded rod attaches to the rotary lever for positive actuation. The rotary lever operates in either direction and adjusts laterally to any position through 360°. The threaded rod pivots in two planes. The actuator has no spring return, but is controlled directly by the movement of the actuating device.

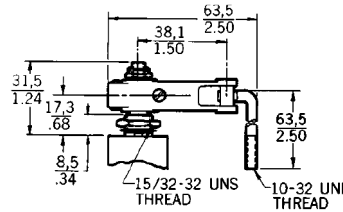

### Roller Lever Actuators

For cam and slide actuation with more than a 30° rise. The actuator is available in clockwise or counterclockwise operation with a spring-return mechanism. The actuator adjusts laterally to any position through 360°. The roller is laminated phenolic.

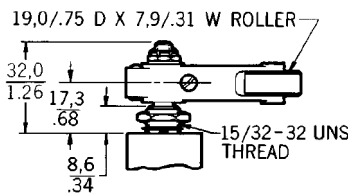

# MICRO SWITCH™ Environmentally Sealed Limit Switches, EN Series

## DIMENSIONAL DRAWINGS

Figure 3. Standard-size EN Switches

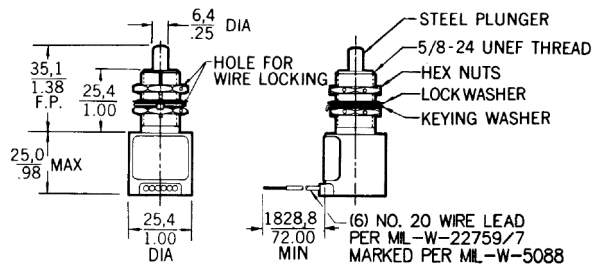
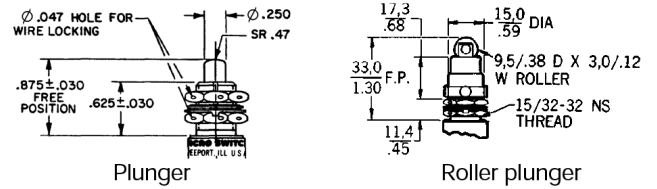

Figure 4. Miniature-size EN Switches

### 600EN actuators



### 400EN actuators

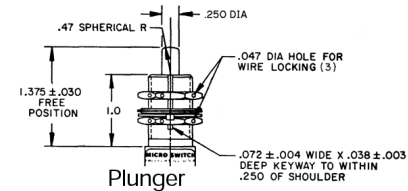
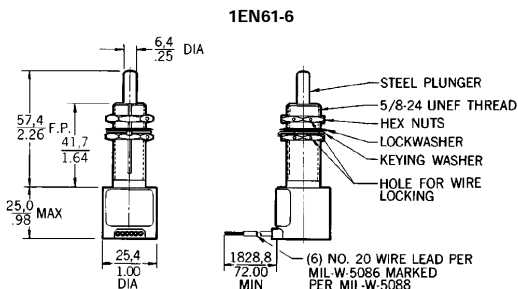
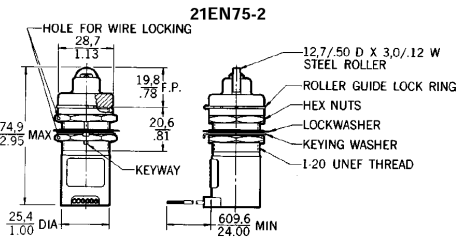
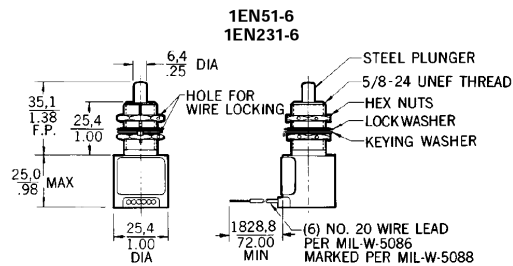
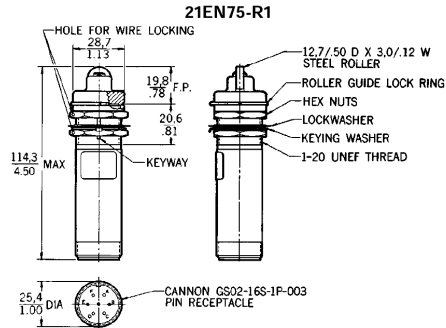
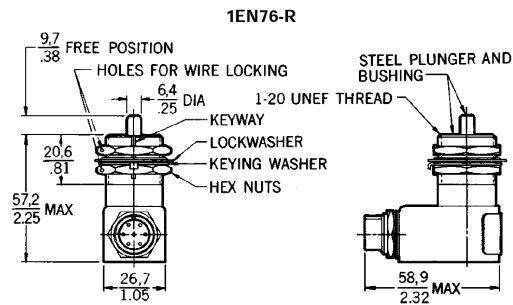
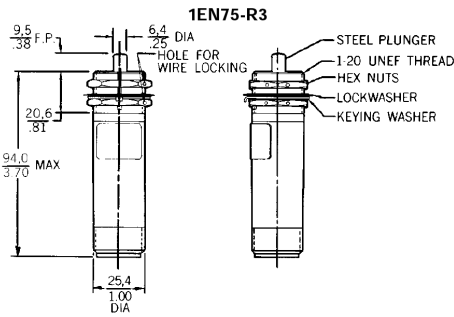
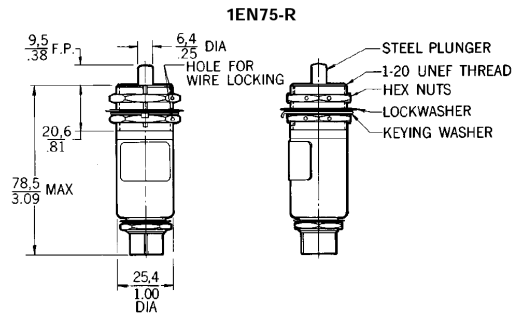

Figure 5. Special-purpose EN Switches

### Standard size EN switches













NOTE: Steel plunger and actuators are made from stainless steel.

Key: 0.0 = mm  
0.00 = inches

# MICRO SWITCH™ Environmentally Sealed Limit Switches, EN Series

Table 6. Replacement Parts

	Catalog Listing	Description	Used On
	6PA30	Roller lever arm	30EN Series
	6PA31	Linkage lever arm	40EN Series
	6PA32	Roller lever arm	1EN and 1HE Series
	6PA202-EN	Roller lever arm	600EN and 600HE Series
	15PA104	Roller guide and locking ring	21EN, 422/424EN Series (5/8 in bushing)
	15PA105	Roller guide and locking ring	622/624EN Series (15/32 in bushing)
	15PA137	Locking ring only	21EN 422/424EN Series (5/8 in bushing)
	15PA107	Locking ring only	622EN and 624EN Series (15/32 in bushing)
	19PA8	Military-type mounting hardware	1EN Series (5/8 in bushing)
	19PA9	Military-type mounting hardware	600EN Series (15/32 in bushing)

## ADDITIONAL MATERIALS

The following associated literature is available on the Honeywell web site at [sensing.honeywell.com](http://sensing.honeywell.com):

- Product line guide
- Product range guide
- Aerospace and defense product range guide

### **WARNING** **PERSONAL INJURY**

DO NOT USE these products as safety or emergency stop devices or in any other application where failure of the product could result in personal injury.

**Failure to comply with these instructions could result in death or serious injury.**

### **WARNING** **MISUSE OF DOCUMENTATION**

- The information presented in this product sheet is for reference only. Do not use this document as a product installation guide.
- Complete installation, operation, and maintenance information is provided in the instructions supplied with each product.

**Failure to comply with these instructions could result in death or serious injury.**

### Find out more

Honeywell serves its customers through a worldwide network of sales offices, representatives and distributors. For application assistance, current specifications, pricing or name of the nearest Authorized Distributor, contact your local sales office. To learn more about Honeywell's sensing and control products, call **+1-815-235-6847** or **1-800-537-6945**, visit **[sensing.honeywell.com](http://sensing.honeywell.com)**, or e-mail inquiries to **[info.sc@honeywell.com](mailto:info.sc@honeywell.com)**

Sensing and Productivity Solutions  
Honeywell  
1985 Douglas Drive North  
Golden Valley, MN 55422  
**[honeywell.com](http://honeywell.com)**

### Warranty/Remedy

Honeywell warrants goods of its manufacture as being free of defective materials and faulty workmanship. Honeywell's standard product warranty applies unless agreed to otherwise by Honeywell in writing; please refer to your order acknowledgement or consult your local sales office for specific warranty details. If warranted goods are returned to Honeywell during the period of coverage, Honeywell will repair or replace, at its option, without charge those items it finds defective. **The foregoing is buyer's sole remedy and is in lieu of all other warranties, expressed or implied, including those of merchantability and fitness for a particular purpose. In no event shall Honeywell be liable for consequential, special, or indirect damages.**

While we provide application assistance personally, through our literature and the Honeywell web site, it is up to the customer to determine the suitability of the product in the application.

Specifications may change without notice. The information we supply is believed to be accurate and reliable as of this printing. However, we assume no responsibility for its use.

# Honeywell

Компания «Океан Электроники» предлагает заключение долгосрочных отношений при поставках импортных электронных компонентов на взаимовыгодных условиях!

Наши преимущества:

- Поставка оригинальных импортных электронных компонентов напрямую с производств Америки, Европы и Азии, а так же с крупнейших складов мира;
- Широкая линейка поставок активных и пассивных импортных электронных компонентов (более 30 млн. наименований);
- Поставка сложных, дефицитных, либо снятых с производства позиций;
- Оперативные сроки поставки под заказ (от 5 рабочих дней);
- Экспресс доставка в любую точку России;
- Помощь Конструкторского Отдела и консультации квалифицированных инженеров;
- Техническая поддержка проекта, помощь в подборе аналогов, поставка прототипов;
- Поставка электронных компонентов под контролем ВП;
- Система менеджмента качества сертифицирована по Международному стандарту ISO 9001;
- При необходимости вся продукция военного и аэрокосмического назначения проходит испытания и сертификацию в лаборатории (по согласованию с заказчиком);
- Поставка специализированных компонентов военного и аэрокосмического уровня качества (Xilinx, Altera, Analog Devices, Intersil, Interpoint, Microsemi, Actel, Aeroflex, Peregrine, VPT, Syfer, Eurofarad, Texas Instruments, MS Kennedy, Miteq, Cobham, E2V, MA-COM, Hittite, Mini-Circuits, General Dynamics и др.);

Компания «Океан Электроники» является официальным дистрибьютором и эксклюзивным представителем в России одного из крупнейших производителей разъемов военного и аэрокосмического назначения «JONHON», а так же официальным дистрибьютором и эксклюзивным представителем в России производителя высокотехнологичных и надежных решений для передачи СВЧ сигналов «FORSTAR».



## JONHON

«JONHON» (основан в 1970 г.)

Разъемы специального, военного и аэрокосмического назначения:

(Применяются в военной, авиационной, аэрокосмической, морской, железнодорожной, горно- и нефтедобывающей отраслях промышленности)

«FORSTAR» (основан в 1998 г.)

ВЧ соединители, коаксиальные кабели, кабельные сборки и микроволновые компоненты:

(Применяются в телекоммуникациях гражданского и специального назначения, в средствах связи, РЛС, а так же военной, авиационной и аэрокосмической отраслях промышленности).



Телефон: 8 (812) 309-75-97 (многоканальный)

Факс: 8 (812) 320-03-32

Электронная почта: [ocean@oceanchips.ru](mailto:ocean@oceanchips.ru)

Web: <http://oceanchips.ru/>

Адрес: 198099, г. Санкт-Петербург, ул. Калинина, д. 2, корп. 4, лит. А