

Flexible and Durable Activations for Multiple Systems

525 Series Service Fittings provide an expanded range of services to include audio/video devices. 525 Series Service Fittings' four-piece design delivers the flexibility of interchangeable faceplates and the durability to withstand multiple moves, adds and changes. These fittings can be applied to Walkerduct® Pro Series, Walkerduct® Underfloor Duct, Flushduct® and Walker 800 Series Floor Boxes.

525 Series Service Fittings are made from die-cast aluminum with a brushed satin finish. Each pedestal provides a single service, with multiple fittings required for two or more services. This line of fittings is ideal for use in schools, commercial office spaces and in labs.



525 Series Fittings provide single service wiring solutions.

FEATURES & BENEFITS

- **All 525 Series Fittings are UL Listed to U.S. and Canadian underfloor duct safety standards.**
- **Enlarged baseplate openings.** Two openings in the baseplate have been enlarged to accept 1 1/4" [32mm] locking nipple. Third opening accepts 1" [25mm] locking nipple. Provides greater wiring capacity.
- **Unique 3-position baseplate.** Allows fitting to be centered or adjusted 3/4" [19.1mm] to one side of center. This integral flexibility permits the fitting to be placed clear of furniture, equipment or adjacent fittings.
- **Interchangeable faceplates.** The 525 Series uses the same faceplates as the previous 505 Series four-piece fittings. Functional changes are now as simple as changing faceplates instead of entire activations.
- **A/V compatibility.** Accepts Extron® Electronics and Ortronics® audio/video devices.
- **Die-cast aluminum with satin finish.** Durable construction provides a fitting that performs and maintains a good appearance after years of service.
- **Flexible four-piece design.** Accommodates two removable faceplates. Choices include blank, power and communication styles. Reduces labor cost for making moves and changes.
- **New housing design.** Reduces the amount of visible lines and angles, improving aesthetic impact.
- **Datacom connectivity options.** Accepts industry standard and proprietary devices from a wide range of manufacturers to provide a seamless and aesthetically pleasing interface for voice, data, audio, and video applications at the point of use.

Four-Piece Service Fittings

Catalog No./Item	Description/Specifications
525A 	Service Fitting – 1" [25mm] I.D. grommet one side.
525B 	Service Fitting – 1" [25mm] I.D. grommet both sides.
525C 	Service Fitting – 1 1/4" [32mm] I.D. grommet one side.
525D 	Service Fitting – 1 1/4" [32mm] I.D. grommet both sides.
525F 	Service Fitting – Duplex receptacle opening, one side.
525G 	Service Fitting – Duplex receptacle opening, both sides



Catalog No./Item	Description/Specifications
525H 	Service Fitting – 20A, 125V duplex receptacle, one side.
525I 	Service Fitting – 20A, 125V duplex receptacle, both sides.
525J 	Service Fitting – Decora or GFI receptacle opening, one side.
525RT 	Service Fitting – Includes faceplate with opening, one side. Ortronics Series II and TracJack adapters included.
525ACT 	Service Fitting – Includes faceplate with opening, one side. Activate CM-MAB adapter included.

525 Series Accessories

Catalog No./Item	Description/Specifications
500RT 	Faceplate – Single opening. Ortronics Series II and TracJack adapters included.
500ACT  2 5/8" [67mm] 4 7/16" [113mm]	Faceplate – Single opening. Activate CM-MAB adapter included.
500B 	Faceplate – Blank.
500-MAAP 	Faceplate – Accepts Extron® Electronics MAAP device plates.
500T 	Faceplate – 1" [25mm] I.D. grommeted hole.

Catalog No./Item	Description/Specifications																																	
500SP- 	Faceplate – Single opening. Suffix indicates hole diameter.																																	
	<table border="1" style="width: 100%;"> <thead> <tr> <th>SUFFIX</th> <th colspan="2">HOLE DIAMETER</th> </tr> </thead> <tbody> <tr> <td>1/2</td> <td>1/2"</td> <td>[12.7mm]</td> </tr> <tr> <td>7/8</td> <td>7/8"</td> <td>[22.2mm]</td> </tr> <tr> <td>1.0625</td> <td>1.0625"</td> <td>[27mm]</td> </tr> <tr> <td>1 1/8</td> <td>1 1/8"</td> <td>[29mm]</td> </tr> <tr> <td>1.39</td> <td>1.39"</td> <td>[35mm]</td> </tr> <tr> <td>1 7/16</td> <td>1 7/16"</td> <td>[37mm]</td> </tr> <tr> <td>1 1/2</td> <td>1 1/2"</td> <td>[38mm]</td> </tr> <tr> <td>1 9/16</td> <td>1 9/16"</td> <td>[40mm]</td> </tr> <tr> <td>1 5/8</td> <td>1 5/8"</td> <td>[41mm]</td> </tr> <tr> <td>2</td> <td>2"</td> <td>[51mm]</td> </tr> </tbody> </table>	SUFFIX	HOLE DIAMETER		1/2	1/2"	[12.7mm]	7/8	7/8"	[22.2mm]	1.0625	1.0625"	[27mm]	1 1/8	1 1/8"	[29mm]	1.39	1.39"	[35mm]	1 7/16	1 7/16"	[37mm]	1 1/2	1 1/2"	[38mm]	1 9/16	1 9/16"	[40mm]	1 5/8	1 5/8"	[41mm]	2	2"	[51mm]
SUFFIX	HOLE DIAMETER																																	
1/2	1/2"	[12.7mm]																																
7/8	7/8"	[22.2mm]																																
1.0625	1.0625"	[27mm]																																
1 1/8	1 1/8"	[29mm]																																
1.39	1.39"	[35mm]																																
1 7/16	1 7/16"	[37mm]																																
1 1/2	1 1/2"	[38mm]																																
1 9/16	1 9/16"	[40mm]																																
1 5/8	1 5/8"	[41mm]																																
2	2"	[51mm]																																
500DR 	Faceplate – For single duplex receptacle.																																	
500-GFI 	Faceplate – For Decora or GFI device.																																	
525HB 	Housing and Base Plate – Only.																																	

Activation Accessories

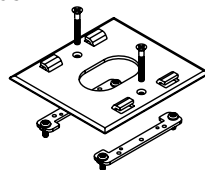
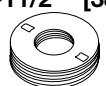
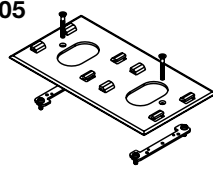
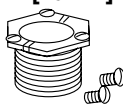
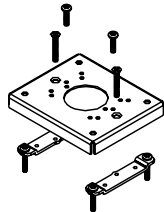
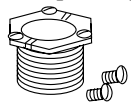
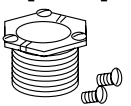
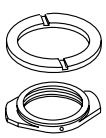
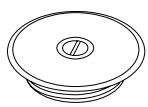
Catalog No./Item	Description/Specifications	Catalog No./Item	Description/Specifications
436-2-7/8 [22.2mm] -11/2 [38mm] -2 [51mm] -23/8 [60mm] -3 [76mm] 	Afterset Inserts for Duct – 2" [51mm] IPS. 2 1/2" [64mm] core drill size; 2 1/4" [57mm] hole saw size. Suffix denotes height.	825SFCK 	Conversion Kit – To attach service fitting to 800 Series floor boxes. Includes 825C Ring, 1124L-1 Locking Nipple, and 825P-1 Adapter.
424-3/4 [19.1mm] -1 [25mm] 	Extensions – For 2" [51mm] IPS preset or afterset inserts. Suffix denotes height of extension.	430S505 	Single Trim Plate – To attach fitting to Walkerdect Pro Series Preset. Base of 525 fitting not needed.
1126A-1/4 [6.4mm] -3/4 [19.1mm] -1 [25mm] -11/4 [32mm] -11/2 [38mm] 	Adapter – To change 2" [51mm] IPS preset or afterset to reduced opening size. Suffix denotes opening size.	431D505 	Double Trim Plate – To attach two fittings to Walkerdect Pro Series Presets. Base of 525 fitting not needed.
1124-1 [25mm] 1124L-1 [25mm] 	Locking Nipple – For 1" [25mm] IPS opening; 1" [25mm] long. Locking Nipple – For 1" [38mm] IPS opening; 1 1/2" [38mm] long.	428B525 	Flush Carpet Plate – To attach to Walkerdect Pro Series Plate. Includes hardware.
1124-11/4 [38mm] 1124L-11/4 [38mm] 	Locking Nipple – For 1 1/4" [32mm] IPS opening; 1" [25mm] long. Locking Nipple – For 1 1/4" [32mm] IPS opening; 1 1/2" [38mm] long.		
1124F-1 [25mm] 	Locking Nipple – For 1" [25mm] IPS opening; 5/8" [16mm] long. For use on Flushduct Infloor Raceway.		
455F-1 	Outlet Flange – For 1 5/8" [241mm] diameter opening on Flushduct Infloor Raceway. Accepts 1" [25mm] locking nipple.		
1044B 1044S For 3/4" IPS <hr/> 1045B 1045S For 1" IPS <hr/> 1046B 1046S For 1 1/4" IPS <hr/> 1043B 1043S For 2" IPS 	Blanking Plates – 3 1/2" [89mm] diameter top plate NOTE: B - Brass S - Stainless Steel		

Cross Reference	
OLD CATALOG NUMBER	NEW CATALOG NUMBER
505A, 501E	525A
505ACT	525ACT
505B, 502E	525B
505C, 503E	525C
505F	525F
505G	525G
505H, 523E	525H
505HB	525HB
505I	525I
505J	525J
505RT	525RT



Electrical Wiring Systems

60 Woodlawn Street
West Hartford, CT 06110
Phone: 1.877.BY.LEGRAND (295-3472)
www.legrand.us

570 Applewood Crescent
Vaughan, Ontario L4K 4B4
Phone: 905.738.9195
www.legrand.ca



Компания «Океан Электроники» предлагает заключение долгосрочных отношений при поставках импортных электронных компонентов на взаимовыгодных условиях!

Наши преимущества:

- Поставка оригинальных импортных электронных компонентов напрямую с производств Америки, Европы и Азии, а так же с крупнейших складов мира;
- Широкая линейка поставок активных и пассивных импортных электронных компонентов (более 30 млн. наименований);
- Поставка сложных, дефицитных, либо снятых с производства позиций;
- Оперативные сроки поставки под заказ (от 5 рабочих дней);
- Экспресс доставка в любую точку России;
- Помощь Конструкторского Отдела и консультации квалифицированных инженеров;
- Техническая поддержка проекта, помощь в подборе аналогов, поставка прототипов;
- Поставка электронных компонентов под контролем ВП;
- Система менеджмента качества сертифицирована по Международному стандарту ISO 9001;
- При необходимости вся продукция военного и аэрокосмического назначения проходит испытания и сертификацию в лаборатории (по согласованию с заказчиком);
- Поставка специализированных компонентов военного и аэрокосмического уровня качества (Xilinx, Altera, Analog Devices, Intersil, Interpoint, Microsemi, Actel, Aeroflex, Peregrine, VPT, Syfer, Eurofarad, Texas Instruments, MS Kennedy, Miteq, Cobham, E2V, MA-COM, Hittite, Mini-Circuits, General Dynamics и др.);

Компания «Океан Электроники» является официальным дистрибьютором и эксклюзивным представителем в России одного из крупнейших производителей разъемов военного и аэрокосмического назначения «JONHON», а так же официальным дистрибьютором и эксклюзивным представителем в России производителя высокотехнологичных и надежных решений для передачи СВЧ сигналов «FORSTAR».



JONHON

«JONHON» (основан в 1970 г.)

Разъемы специального, военного и аэрокосмического назначения:

(Применяются в военной, авиационной, аэрокосмической, морской, железнодорожной, горно- и нефтедобывающей отраслях промышленности)

«FORSTAR» (основан в 1998 г.)

ВЧ соединители, коаксиальные кабели, кабельные сборки и микроволновые компоненты:

(Применяются в телекоммуникациях гражданского и специального назначения, в средствах связи, РЛС, а так же военной, авиационной и аэрокосмической отраслях промышленности).



Телефон: 8 (812) 309-75-97 (многоканальный)

Факс: 8 (812) 320-03-32

Электронная почта: ocean@oceanchips.ru

Web: <http://oceanchips.ru/>

Адрес: 198099, г. Санкт-Петербург, ул. Калинина, д. 2, корп. 4, лит. А