



**ULTRAVOLT® EFL SERIES**  
ENHANCED FLOATING HOT DECK  
LOW-VOLTAGE POWER SUPPLIES WITH  
ISOLATED DIGITAL AND ANALOG I/O





---

# **Enhanced** floating hot deck low- voltage power supplies

The EFL series of floating hot deck, low-voltage (LV) power supplies offers an integrated solution for systems requiring LV power and controls with high voltage isolation. Combining a highly isolated, DC-to-DC, multi-output low-voltage power supply (LVPS) with an advanced isolated digital and analog I/O topology, the EFL subsystem provides both power and controls to floating-hot-deck circuitry. This solution, when combined with one or more UltraVolt® HVPS or other circuitry, can provide high-performance solutions for a variety of applications.

## Features

- › Precision analog control
- › Linearity of  $\pm 0.05\%$  and accuracy of  $\pm 0.2\%$
- › 10ppm temperature coefficient
- › Isolated up to 15 kV or 30 kV
- › Isolation resistance of 150 G $\Omega$  (15 kV) or 2 G $\Omega$  (30 kV)
- › 4 regulated floating LV power outputs
- › Isolated digital and analog I/O to and from floating hot deck

## Typical Applications

- › Floating/stacked ion or e-beam biases
- › Floating filament bias
- › Floating pulsed and gated grids
- › Floating capacitance meters
- › Floating high side current monitors
- › Floating leakage testers





## NORMAL, HALF-QUIET, AND QUIET MODES

All EFLs feature a mode control. Three different models—normal, half-quiet, and quiet—are selectable via the voltage level at the mode pin. A voltage between -1.0 and +0.8 V keeps the unit in normal mode; the up and down analog channels follow their inputs. If the mode feature is not used, the mode pin must be grounded for the EFL to operate properly.

A voltage more negative than -4.00 V places the EFL in half-quiet mode. The up channels do not respond to changes in their inputs in half-quiet mode.

A voltage greater than +3.75 V and less than +5.0 V places the EFL in quiet mode. In quiet mode, the up and down channels do not respond to changes in their inputs.

The voltage level at the mode pin must not exceed +5.0 V at any time. Please contact Advanced Energy® for an analysis of your requirements.

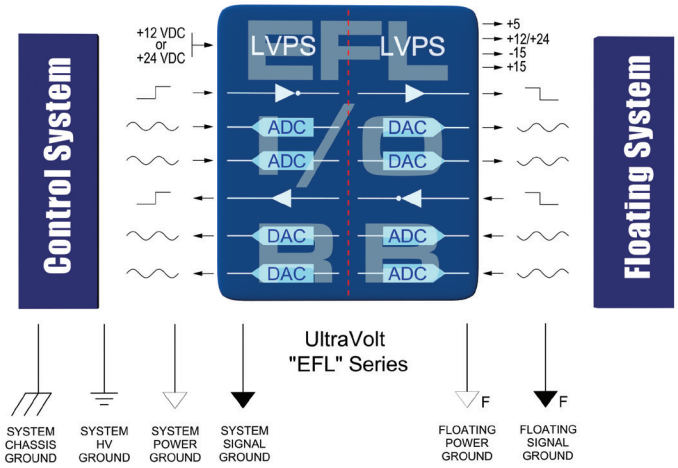

*Note: If a voltage > 0.8 V is applied to the mode pin, it must source less than 400  $\mu$ A.*

PARAMETER	CONDITIONS	MODELS			UNITS
Input Power		12 W	24 W	36 W (15 kV only)	
Voltage Range	Full Power	+12 $\pm$ 5%	+24 $\pm$ 10%	+24 $\pm$ 10%	VDC
Current	Standby (Disabled)	< 150	< 100	< 100	mA
Current	No Load	< 0.50	< 0.50	< 0.50	A
Current	Max Load	< 2.50	< 2.30	< 3.00	A
AC Ripple Current	Nominal Input, Full Load	< 50	< 50	< 50	mA pk to pk
Local Controls: Reference		All Types			
Output Voltage	T = +25°C, Initial Value	+5.1 $\pm$ 2%			VDC
Output Impedance	T = +25°C	464 $\pm$ 1%			$\Omega$
Stability	Over Full Temperature Range	0.4			mV/°C
Local Controls: LVPS Enable/Disable		All Types			
Power Supply On	Open, or a Voltage Above TTL High (Isorce < 400 $\mu$ A)	+3.2 to 5			VDC
Power Supply Off	Grounded, or a Voltage Below TTL Low	< 0.8 (Isink 1 mA min)			VDC
Input/Output Isolation		15EFL	30EFL		
Isolation Voltage	Continuous	15	30		kV
Isolation Resistance	All Inputs to All Outputs	150	2		G $\Omega$
Leakage Capacitance	All Inputs to All Outputs	< 40 std, < 50 "-E"	< 40 std		pF



PARAMETER	CONDITIONS	MODELS			UNITS
<b>Isolated Power Outputs</b>		<b>12 W</b>	<b>24 W</b>	<b>36 W (15 kV only)</b>	
<b>Output #1 Power</b>	Nominal Input, Max Iout	12	24	36	W
<b>Output #1 Voltage</b>	Nominal Input Voltage Range	+12 ±2%	+24 ±2%	+24 ±2%	VDC
<b>Output #1 Current</b>	Min to Max	0 to 1	0 to 1	0 to 1.5	A
<b>Output #1 Line Regulation</b>	Nominal Input Range, Full Load	< 0.1%	< 0.1%	< 0.1%	VDC
<b>Output #1 Load Regulation</b>	No Load to Full Load	< 0.25%	< 0.30%	< 0.40%	VDC
<b>Output #1 Ripple</b>	Full Load	< 2.5%	< 1.5%	< 1.5%	V pk to pk
<b>Output #2 and #4 Voltage</b>	Nominal Input Voltage Range	±15 ±5%	±15 ±5%	±15 ±5%	VDC
<b>Output #2 and #4 Current</b>	Min to Max	0 to 50	0 to 50	0 to 50	mA
<b>Output #2 and #4 Line Regulation</b>	Nominal Input Range, Full Load	< 0.3%	< 0.3%	< 0.3%	VDC
<b>Output #2 and #4 Load Regulation</b>	No Load to Full Load	< 5%	< 1%	< 1%	VDC
<b>Output #2 and #4 Ripple</b>	Full Load	< 2.5%	< 2.5%	< 2.5%	V pk to pk
<b>Output #3 Voltage</b>	Nominal Input Voltage Range	+5.1 ±1%	+5.1 ±1%	+5.1 ±1%	VDC
<b>Output #3 Current</b>	Min to Max	500	500	500	mA
<b>Output #3 Line Regulation</b>	Nominal Input Range, Full Load	< 1%	< 1%	< 1%	VDC
<b>Output #3 Load Regulation</b>	No Load to Full Load	< 1%	< 1%	< 1%	VDC
<b>Output #3 Ripple</b>	Full Load	< 4%	< 4%	< 4%	V pk to pk
<b>Isolated Controls: TTL Channel "Up"</b>		<b>All Types</b>			
<b>Local Input</b>	Source Voltage, Sink Current	0 ≤ 0.5 (Isink 3 mA min)			
		1 ≥ 2.4 (300 μA max or open collector)			VDC
<b>Isolated Output</b>	Inverted and Buffered TTL	1 ≥ 2.4, 0 ≤ 0.55 ± (sources 0.8 mA, sinks 3 mA)			VDC
<b>Baud Rate</b>	Duty Cycle	< 15			ms
<b>Isolated Controls: Analog "Up"</b>		<b>12 V</b>	<b>24 V</b>		
<b>Local Input Voltage</b>	Range	0 to +5	0 to +10		VDC
<b>Isolated Output Voltage</b>	Range	0 to +5	0 to +10		VDC
<b>Local Input Impedance</b>		20.0 K			Ω
<b>Initial Offset Error</b>		< ±2			mV
<b>Gain Error</b>	Full Scale	< ±0.2%			VDC
<b>Linearity Error</b>	Full Scale	< ±0.05%			VDC
<b>Stability</b>	30 Min Warmup, Per 8 h, per day	< 0.02%			VDC
<b>Temperature Coefficient</b>	0 to +55 °C	< ±10			ppm/°C
<b>Bandwidth</b>	Symmetric or Asymmetric Signal	DC to 4			Hz



**-RB' ISOLATED CONTROLS: TTL CHANNEL "DOWN"**

Parameter	Conditions	All Types	Units
Isolated 'Hot Deck' Input	Source Voltage, Sink Current	$0 \leq 0.5$ (Isink 1 mA Min)	VDC
		$1 \geq 2.4$ (300 $\mu$ A max or open collector)	
Local Output	Inverted and Buffered TTL	$1 > 2.4$ (sources 0.8 mA)	VDC
		$0 < 0.55$ (sinks 10 mA)	
Propagation Delay	Duty Cycle	$< 15$	ms

**ISOLATED CONTROLS: ANALOG CHANNELS #1 and #2 "DOWN"**

Parameter	Conditions	All Types	Units
Isolated 'Hot Deck' +Input	Range	0 to +5 for 12 V and 0 to +10 for 24 V	VDC
Isolated 'Hot Deck' -Input	Range	0 to -5 for 12 V and 0 to -10 for 24 V	VDC
Isolated 'Hot Deck' + or -Input impedance	Signal Source	$> 10$	M $\Omega$
Local Output +Voltage	Range	0 to +5 for 12 V and 0 to +10 for 24 V	VDC
Local Output -Voltage	Range	0 to -5 for 12 V and 0 to -10 for 24 V	VDC
Initial Offset Error	Signal Source	$< \pm 2$	mVDC
Gain Error	Full Scale	$< \pm 0.2\%$	VDC
Linearity Error	Full Scale	$< \pm 0.05\%$	VDC
Stability	30 Min Warmup, Per 8 h, Per Day	$< 0.01\%/< 0.02\%$	VDC
Temperature Coefficient	-20 to +55°C	$< \pm 10$	ppm/°C
Bandwidth	Symmetric or Asymmetric Signal	DC to 4	Hz
Temperature		All Types	
Operating	Full Load, Case Measurement	-20 to +55	°C
Storage	Non-operating, Case Measurement	-55 to +85	°C
Thermal Shock	Mil-Std-810, Method 503-4, Proc. II	-20 to +55	°C
Altitude		All Types	
Operating	All Operating Conditions	Sea level to vacuum	-
Storage	Non-operating	Sea level to vacuum	-
Shock and Vibration		All Types	
Shock	Mil-Std-810, Method 516.5, Proc. IV	20	Gs
Vibration	Mil-Std-810, Method 514.5, Fig. 514.5C-3	10	Gs

Note: Analog channels #1 and #2 DOWN parameters are valid for outputs in the range of 10 to 100% of maximum.

**LOCAL CONNECTIONS**

Pin	Function
1	INPUT POWER GROUND RETURN
2	POSITIVE POWER INPUT
3	LVPS ENABLE/DISABLE/SYNC IN
4	TTL UP
5	SIGNAL GROUND RETURN
6	ANALOG UP CHANNEL 1
7	+5 V REFERENCE OUTPUT
8	ANALOG DOWN CHANNEL 1, +
9	ANALOG DOWN CHANNEL 1, -
10	ANALOG DOWN CHANNEL 2, +
11	ANALOG DOWN CHANNEL 2, -
12	ANALOG UP CHANNEL 2
13	MODE
14	TTL OUTPUT (INVERTED DIGITAL DOWN CHANNEL 1)

**ISOLATED/FLOATING CONNECTIONS**

Pin	Function
1	ANALOG DOWN CHANNEL 1, +
2	ANALOG DOWN CHANNEL 1, -
3	ANALOG DOWN CHANNEL 2, +
4	ANALOG DOWN CHANNEL 2, -
5	+15 VDC OUTPUT
6	ANALOG UP CHANNEL 2
7	FLOATING TTL INPUT (DIGITAL DOWN CHANNEL 1)
8	FLOATING POWER GROUND RETURN
9	FLOATING +12 VDC OR +24VDC OUTPUT
10	FLOATING -15 VDC OUTPUT
11	FLOATING TTL UP
12	FLOATING SIGNAL GROUND RETURN
13	FLOATING ANALOG UP CHANNEL 1
14	FLOATING +5.1 VDC REFERENCE OUTPUT

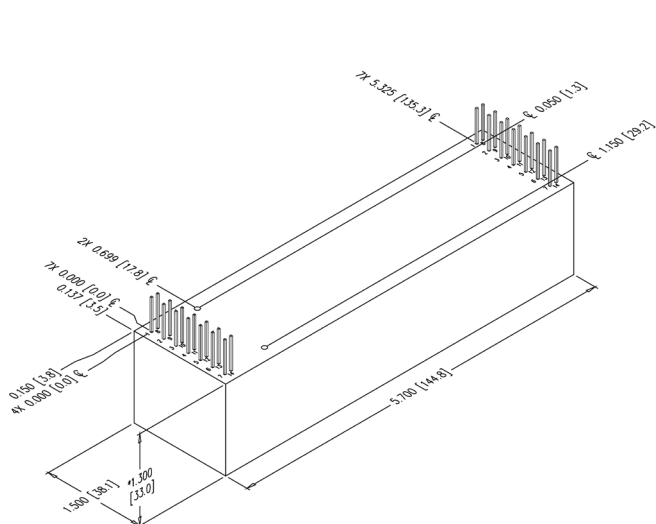

15EFL Module

Note: Pins appear shorter in the outline drawing than actual module to ease visibility of pinout numbers. Minimum pin height from the cover is 7.62 mm (0.300").

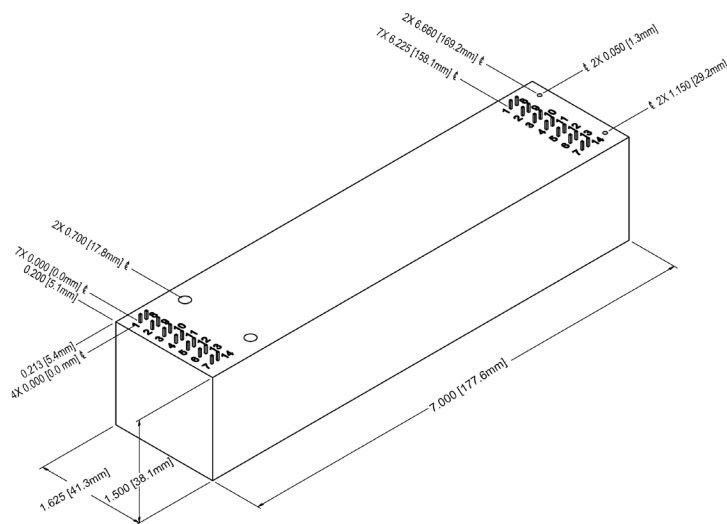

30EFL Module

## PHYSICAL SPECIFICATIONS

**Construction** Epoxy-filled DAP box certified to ASTM-D-5948

### Size

**Volume**  
15EFL: 181.9 cc (11.1 in<sup>3</sup>)  
30EFL: 275.3 cc (16.8 in<sup>3</sup>)

**Weight**  
15EFL: 377.1 g (13.3 oz)  
30EFL: 569.8 g (20.1 oz)

### Tolerance

**Overall** ±1.27 mm (0.050")  
**Pin to Pin** ±0.38 mm (0.015")  
**15EFL** Mounting hole locations ±0.64 mm (0.025")  
**30EFL** Mounting hole locations ±0.76 mm (0.030")

## ORDERING INFORMATION

<b>Type</b>	15 kV Isolation	15EFL
	30 kV Isolation	30EFL
<b>Input Voltage</b>	12 VDC Nominal	12
	24 VDC Nominal	24
<b>Power</b>	Watts Output (12 Vin Only)	-12 W
	Watts Output (24 Vin Only)	-24 W
	Watts Output (15 kVout, 24 Vin Only)	-36 W
<b>Standard Features</b>	(1) Digital Up Channel and (2) Analog Up Channels	-I/O
	(1) Digital Down Channel and (2) Analog Down Channels	-R/B
<b>Options</b>	Partial Mu-Metal Shield	-M
<b>Case</b>	Plastic Case—Diallyl Phthalate	Standard
	"Eared" Chassis Mounting Plate (15 kV only)	-E



Non-RoHS compliant units are available. Please contact the factory for more information.

Example: **15EFL12-12W-I/O-RB**

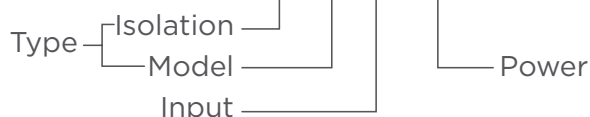





For international contact information, visit [advanced-energy.com](http://advanced-energy.com).



Компания «Океан Электроники» предлагает заключение долгосрочных отношений при поставках импортных электронных компонентов на взаимовыгодных условиях!

Наши преимущества:

- Поставка оригинальных импортных электронных компонентов напрямую с производств Америки, Европы и Азии, а так же с крупнейших складов мира;
- Широкая линейка поставок активных и пассивных импортных электронных компонентов (более 30 млн. наименований);
- Поставка сложных, дефицитных, либо снятых с производства позиций;
- Оперативные сроки поставки под заказ (от 5 рабочих дней);
- Экспресс доставка в любую точку России;
- Помощь Конструкторского Отдела и консультации квалифицированных инженеров;
- Техническая поддержка проекта, помощь в подборе аналогов, поставка прототипов;
- Поставка электронных компонентов под контролем ВП;
- Система менеджмента качества сертифицирована по Международному стандарту ISO 9001;
- При необходимости вся продукция военного и аэрокосмического назначения проходит испытания и сертификацию в лаборатории (по согласованию с заказчиком);
- Поставка специализированных компонентов военного и аэрокосмического уровня качества (Xilinx, Altera, Analog Devices, Intersil, Interpoint, Microsemi, Actel, Aeroflex, Peregrine, VPT, Syfer, Eurofarad, Texas Instruments, MS Kennedy, Miteq, Cobham, E2V, MA-COM, Hittite, Mini-Circuits, General Dynamics и др.);

Компания «Океан Электроники» является официальным дистрибьютором и эксклюзивным представителем в России одного из крупнейших производителей разъемов военного и аэрокосмического назначения «JONHON», а так же официальным дистрибьютором и эксклюзивным представителем в России производителя высокотехнологичных и надежных решений для передачи СВЧ сигналов «FORSTAR».



## JONHON

«JONHON» (основан в 1970 г.)

Разъемы специального, военного и аэрокосмического назначения:

(Применяются в военной, авиационной, аэрокосмической, морской, железнодорожной, горно- и нефтедобывающей отраслях промышленности)

«FORSTAR» (основан в 1998 г.)

ВЧ соединители, коаксиальные кабели, кабельные сборки и микроволновые компоненты:

(Применяются в телекоммуникациях гражданского и специального назначения, в средствах связи, РЛС, а так же военной, авиационной и аэрокосмической отраслях промышленности).



Телефон: 8 (812) 309-75-97 (многоканальный)

Факс: 8 (812) 320-03-32

Электронная почта: [ocean@oceanchips.ru](mailto:ocean@oceanchips.ru)

Web: <http://oceanchips.ru/>

Адрес: 198099, г. Санкт-Петербург, ул. Калинина, д. 2, корп. 4, лит. А