



SOT-25



Pin Definition:

1. Input +
2. Ground
3. Input -
4. Output
5. Vcc

General Description

The TS331 is single precision voltage comparators capable of single-supply or split-supply operation. The specifications as low as 2.0 mV make this device an excellent ground level with single-supply operation. Input offset-voltage selection for many applications in consumer automotive, and It is designed to permit a common mode range-to- industrial electronics.

Features

- Output voltage compatible with DTL, ECL, TTL, MOS and CMOS Logic levels
- Low input bias current 25nA
- Low input offset current $\pm 0.5\text{nA}$
- Low input offset voltage $\pm 2\text{mV}(\text{typ})$
- Input common mode range to ground level
- Differential input voltage range equal to power supply voltage
- Very low supply current drain (0.4mA) - independent of supply voltage
- Wide single-supply range 2V~36V
- Split-supply range $\pm 1\text{V}$ to $\pm 18\text{V}$

Block Diagram

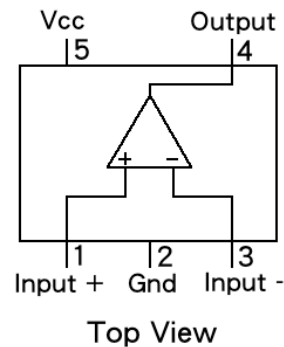

Ordering Information

Part No.	Package	Packing
TS331CX5 RF	SOT-25	3Kpcs / 7" Reel

Absolute Maximum Rating

Parameter	Symbol	Limit	Unit
Supply Voltage	V_{CC}	+36 or ± 18	V
Differential Input Voltage	V_{IDR}	36	V
Input Common Mode Voltage Range	V_{ICR}	-0.3 to 36	V
Input Current	I_{IN}	50	mA
Output Short Circuit to Ground	I_{SC}	Continuous	
Output Sink Current	I_{SINK}	20	mA
Operating Temperature Range	T_{OPR}	-40 ~ +85	$^{\circ}\text{C}$
Junction Temperature	T_J	150	$^{\circ}\text{C}$
Storage Temperature Range	T_{STG}	-65 ~ +150	$^{\circ}\text{C}$
Lead Temperature 1.6mm(1/16") from case for 10Sec.	T_{LEAD}	260	$^{\circ}\text{C}$

Electrical Characteristics ($V_{CC} = 5V$, $T_a=25^{\circ}C$; unless otherwise specified.)

Characteristics	Symbol	Min	Typ	Max	Unit
Input Offset Voltage (note 3)	V_{io}	--	2	5	mV
Input Offset Current, $I_{IN(+)} - I_{IN(-)}$, $V_{CM}=0V$	I_{io}	--	--	50	nA
Input Offset Current (note 4), $I_{IN(+)} - I_{IN(-)}$, $V_{CM}=0V$	I_{IB}	--	--	250	nA
Input Common Mode Voltage Range, $V_{CC}=30V$	V_{ICR}	-0	--	$V_{CC}-1.5$	V
Voltage Gain, $R_L \geq 15K$, $V_{CC}=15V$, $V_o=1V \sim 11V$	A_{VOL}	50	200	--	V/mV
Large Signal Response Time $V_{in}=TTL$ Logic Swing. $V_{ref} = 1.4V$, $V_{RL}=5V$. $R_L=5.1K\Omega$	--	--	300	--	nS
Response Time (note 6), $V_{RL}=5V$. $R_L=5.1K\Omega$	t_{TLH}	--	1.3	--	μS
Output Sink Current, $V_{IN(-)}=1V$, $V_{IN(+)}=0V$, $V_o \leq 1.5V$	I_{SINK}	6.0	16	--	mA
Output Saturation Voltage, $V_{IN(-)}=1V$, $V_{IN(+)}=0V$, $I_{SINK} \leq 4mA$	V_{OL}	--	250	400	mV
Output Leakage Current, $V_{IN(-)}=0V$, $V_{IN(+)}=1V$, $V_o=5V$	I_{OL}	--	0.1	--	nA
Supply Current $R_L = \infty$, $V_{CC} = 5V$ $R_L = \infty$, $V_{CC} = 36V$	I_{CC}	--	0.4 1.0	1.0 2.5	mA

Note 1. The max. Output current may be as high as 20mA, independent of the magnitude of V_{CC} , output short circuits to V_{CC} can cause excessive heating and eventual destruction.

Note 2. This magnitude of input current will only occur if the input leads are driven more negative than ground or the negative supply voltage. This is due to the input PNP collector base junction becoming forward biased acting as an input clamp diode. There is also a lateral PNP parasitic transistor action on the IC chip. This phenomena can cause the output voltage of the comparators to go to the V_{CC} voltage level (or ground if overdrive is large) during the time the input is driven negative. This will not destroy the device and normal output states will recover when the inputs become $-0.3V$ of ground or negative supply.

Note 3. At output switch point, $V_o=1.4V_{dc}$, $R_s=0\Omega$ with V_{CC} from $5V_{dc}$ to $30V_{dc}$, and over the full input common-mode

Note 4. Due to the PNP transistor inputs, bias current will flow out of the inputs, this current is essentially constant independent of the output state, therefore, no loading changes will exist on the input lines.

Note 5. Input common mode of either input should not be permitted to go more than 0.3V negative of ground or minus supply. The upper limit of common mode range is $V_{CC} - 1.5V$ but either or both inputs can be taken to as high as 30volts without damage.

Note 6. Response time is specified with a 100mV step and 5.0mV of overdrive. With larger magnitudes of overdrive faster response times are obtainable.

Application information

This comparator feature high gain, wide bandwidth characteristics. This gives the device oscillation tendencies if the outputs are capacitive coupled to the inputs via stray capacitance. This oscillation manifests itself during output transitions (V_{OL} to V_{OH}). To alleviate this situation input resistors $< 10K\Omega$ should be used. The addition of positive feedback (< 10 mV) is also recommended.

It is good design practice to ground all unused pins. Differential input voltages may be larger than supply voltage without damaging the comparator's inputs. Voltages more negative than $-0.3V$ should not be used.

Application information (continues)

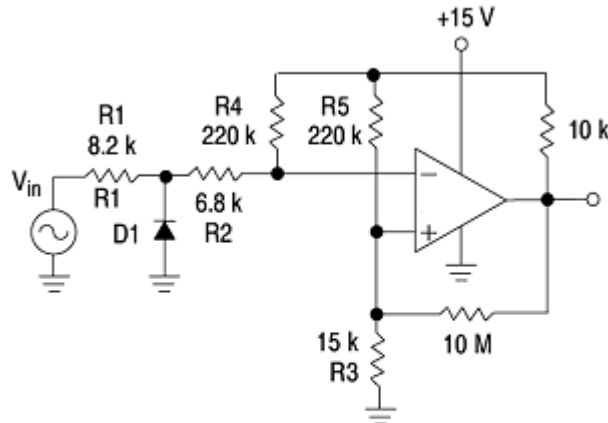

D1 prevents input from going negative by more than 0.6 V.

$$R1 + R2 = R3$$

$$R3 \leq \frac{R5}{10} \text{ for small error in zero crossing.}$$

Figure 4. Zero Crossing Detector (Single Supply)

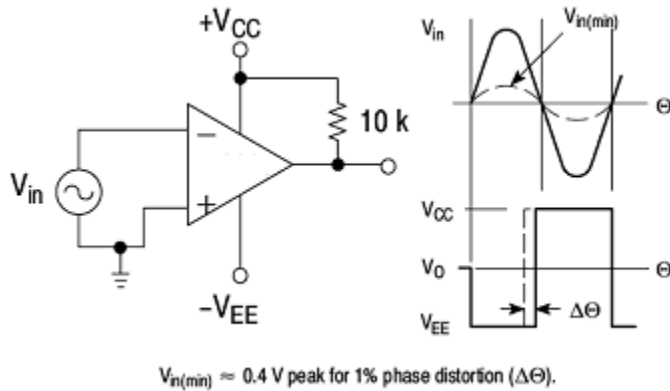

$V_{in(min)} \approx 0.4 \text{ V peak for } 1\% \text{ phase distortion } (\Delta\Theta).$

Figure 6. Time Delay Generator

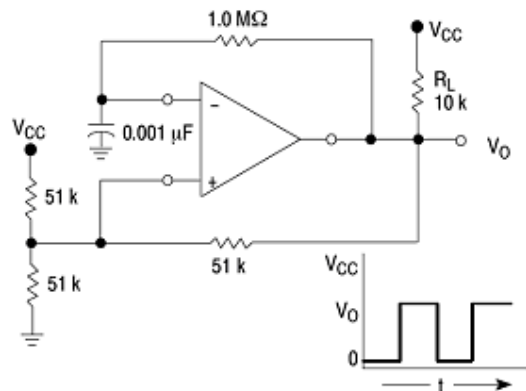

Figure 7. Free-Running Square-Wave Oscillator

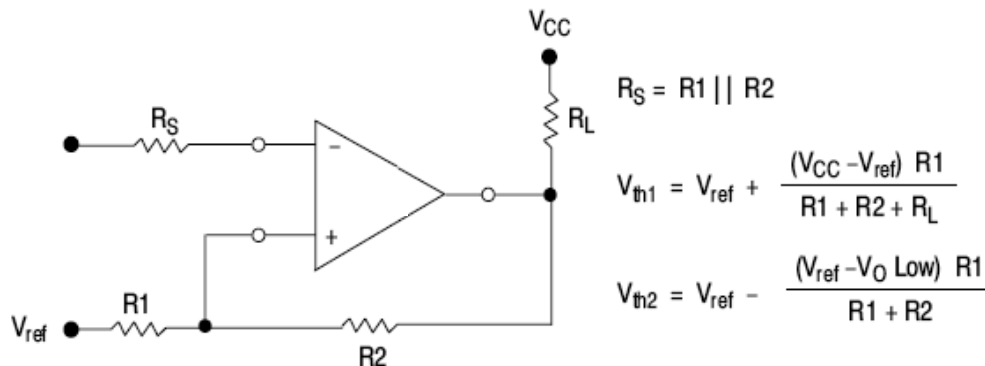
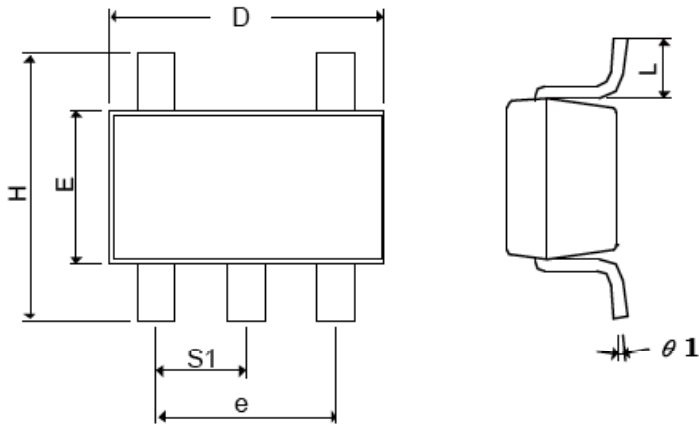

Figure 8. Comparator with Hysteresis

SOT-25 Mechanical Drawing



DIM	MILLIMETERS		INCHES	
	MIN	MAX	MIN	MAX.
A+A1	0.09	1.25	0.0354	0.0492
B	0.30	0.50	0.0118	0.0197
C	0.09	0.25	0.0035	0.0098
D	2.70	3.10	0.1063	0.1220
E	1.40	1.80	0.0551	0.0709
E	1.90 BSC		0.0748 BSC	
H	2.40	3.00	0.09449	0.1181
L	0.35 BSC		0.0138 BSC	
$\theta 1$	0°	10°	0°	10°
S1	0.95 BSC		0.0374 BSC	

Front View

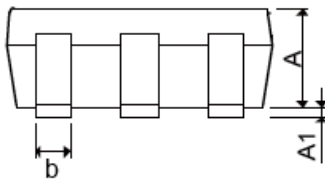

Marking Diagram

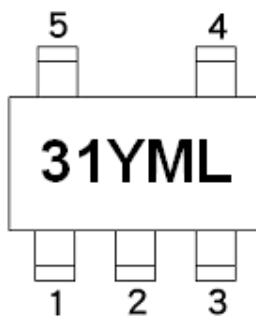

- 31** = Product Code for TS331CX5
- Y** = Year Code
- M** = Month Code
(A=Jan, B=Feb, C=Mar, D=Apl, E=May, F=Jun, G=Jul, H=Aug, I=Sep, J=Oct, K=Nov, L=Dec)
- L** = Lot Code

Notice

Specifications of the products displayed herein are subject to change without notice. TSC or anyone on its behalf, assumes no responsibility or liability for any errors or inaccuracies.

Information contained herein is intended to provide a product description only. No license, express or implied, to any intellectual property rights is granted by this document. Except as provided in TSC's terms and conditions of sale for such products, TSC assumes no liability whatsoever, and disclaims any express or implied warranty, relating to sale and/or use of TSC products including liability or warranties relating to fitness for a particular purpose, merchantability, or infringement of any patent, copyright, or other intellectual property right.

The products shown herein are not designed for use in medical, life-saving, or life-sustaining applications. Customers using or selling these products for use in such applications do so at their own risk and agree to fully indemnify TSC for any damages resulting from such improper use or sale.

Компания «Океан Электроники» предлагает заключение долгосрочных отношений при поставках импортных электронных компонентов на взаимовыгодных условиях!

Наши преимущества:

- Поставка оригинальных импортных электронных компонентов напрямую с производств Америки, Европы и Азии, а так же с крупнейших складов мира;
- Широкая линейка поставок активных и пассивных импортных электронных компонентов (более 30 млн. наименований);
- Поставка сложных, дефицитных, либо снятых с производства позиций;
- Оперативные сроки поставки под заказ (от 5 рабочих дней);
- Экспресс доставка в любую точку России;
- Помощь Конструкторского Отдела и консультации квалифицированных инженеров;
- Техническая поддержка проекта, помощь в подборе аналогов, поставка прототипов;
- Поставка электронных компонентов под контролем ВП;
- Система менеджмента качества сертифицирована по Международному стандарту ISO 9001;
- При необходимости вся продукция военного и аэрокосмического назначения проходит испытания и сертификацию в лаборатории (по согласованию с заказчиком);
- Поставка специализированных компонентов военного и аэрокосмического уровня качества (Xilinx, Altera, Analog Devices, Intersil, Interpoint, Microsemi, Actel, Aeroflex, Peregrine, VPT, Syfer, Eurofarad, Texas Instruments, MS Kennedy, Miteq, Cobham, E2V, MA-COM, Hittite, Mini-Circuits, General Dynamics и др.);

Компания «Океан Электроники» является официальным дистрибьютором и эксклюзивным представителем в России одного из крупнейших производителей разъемов военного и аэрокосмического назначения «JONHON», а так же официальным дистрибьютором и эксклюзивным представителем в России производителя высокотехнологичных и надежных решений для передачи СВЧ сигналов «FORSTAR».



JONHON

«JONHON» (основан в 1970 г.)

Разъемы специального, военного и аэрокосмического назначения:

(Применяются в военной, авиационной, аэрокосмической, морской, железнодорожной, горно- и нефтедобывающей отраслях промышленности)

«FORSTAR» (основан в 1998 г.)

ВЧ соединители, коаксиальные кабели, кабельные сборки и микроволновые компоненты:

(Применяются в телекоммуникациях гражданского и специального назначения, в средствах связи, РЛС, а так же военной, авиационной и аэрокосмической отраслях промышленности).



Телефон: 8 (812) 309-75-97 (многоканальный)

Факс: 8 (812) 320-03-32

Электронная почта: ocean@oceanchips.ru

Web: <http://oceanchips.ru/>

Адрес: 198099, г. Санкт-Петербург, ул. Калинина, д. 2, корп. 4, лит. А