

# IB IL AO 4/8/U/BP-XC-PAC

**Inline analog output terminal,  
version for extreme conditions,  
8 outputs**

Data sheet  
8359\_en\_00

© PHOENIX CONTACT 2012-05-08

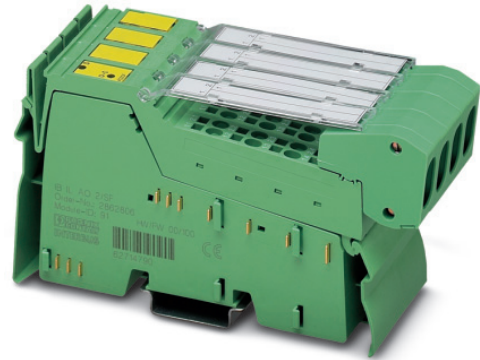

## 1 Description

This terminal is designed for use within an Inline station. This terminal provides an 8-channel output module to output analog standard voltage signals.

The output values are represented by 16-bit or 8-bit values. Thanks to special engineering measures and tests, the terminal can be used under extreme ambient conditions.

## Features

- Eight analog signal outputs
- Connection of actuators in 2-wire technology with shield connection
- Communication via either process data or parameter channel (PCP)
- Channels are configured independently of one another using the bus system.
- Measured values can be represented in four different formats
- Diagnostic indicator
- Can be used under extreme ambient conditions
- Painted PCBs
- Extended temperature range T2 (-40°C ... +55°C)



This data sheet is only valid in association with the IL SYS INST UM E user manual.



Make sure you always use the latest documentation. It can be downloaded at [www.phoenixcontact.net/catalog](http://www.phoenixcontact.net/catalog).

## Table of contents

1	Description.....	1
2	Ordering data.....	3
3	Technical data .....	4
4	Tolerance and temperature response .....	7
5	Tested successfully: Use under extreme ambient conditions .....	8
6	Internal basic circuit diagram .....	9
7	Electrical isolation.....	10
8	Local diagnostic indicators .....	10
9	Terminal point assignment for each connector .....	10
10	Installation instructions .....	11
11	Connection notes.....	11
12	Connection example.....	11
13	Connecting shielded cables using the shield connector .....	12
14	Process data.....	12
15	OUT process data.....	13
	15.1 Output word OUT1 (control word) .....	14
	15.2 Parameters in output word OUT1 .....	15
	15.3 Parameters for configuration .....	15
16	IN process data.....	16
	16.1 Input word IN1 (status word).....	16
	16.2 Input words IN2 to IN5.....	16
17	Formats for representing output values.....	17
	17.1 IB IL format (default setting) .....	17
	17.2 IB ST format .....	18
	17.3 S7-compatible format .....	19
	17.4 "Standardized representation" format.....	20
18	Configuration and analog value transmission .....	21
19	PCP communication .....	22
	19.1 Object dictionary .....	22
	19.2 Object descriptions.....	23

## 2 Ordering data

### Products

Description	Type	Order No.	Pcs. / Pkt.
Inline analog input terminal, version for extreme conditions, complete with accessories (connector and labeling field), 8 outputs, 0 - 10 V, $\pm 10$ V, 2-wire connection technology	IB IL AO 4/8/U/BP-XC-PAC	2701164	1

### Accessories

Description	Type	Order No.	Pcs. / Pkt.
Inline shield connector for analog Inline terminals	IB IL SCN 6-SHIELD-TWIN	2740245	5
Shield connection clamp for applying the shield on busbars	SK 8	3025163	10
Shield connection clamp for applying the shield on busbars	SK 14	3025176	10
Shield connection clamp for applying the shield on busbars	SK 20	3025189	10
Shield connection clamp for applying the shield on busbars	SK 35	3026463	10
Support for mounting on the NS 35/7,5 DIN rail, for 10 mm x 3 mm busbars	AB-SK	3025341	10
Support for direct mounting with contact to the mounting surface	AB-SK 65	3026489	10
Support, made of insulation material, with fixing screws, can be used for either 10 mm x 3 mm or 6 mm x 6 mm busbars	AB-SK/E	3026476	10
Neutral busbar, 3 mm x 10 mm, length: 1000 mm	NLS-CU 3/10 SN 1000MM	0402174	10
Power terminal, conductor cross section: 0.5 - 4 mm <sup>2</sup> , width: 7 mm	AK 4	0404017	50
Power terminal, conductor cross section: 0.5 - 4 mm <sup>2</sup> , width: 7 mm; color: green-yellow	AK 4 GNYE	0421029	50
Power terminal, conductor cross section: 0.5 - 4 mm <sup>2</sup> , width: 7 mm; color: black	AKG 4 BK	0421032	50

### Documentation

Description	Type	Order No.	Pcs. / Pkt.
"Automation terminals of the Inline product range" user manual	IL SYS INST UM E	-	-

### 3 Technical data

#### Dimensions (nominal sizes in mm)

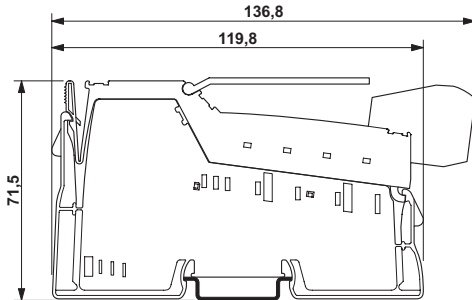

Housing dimensions (width x height x depth)	12.2 x 136.8 x 71.5 mm
---	------------------------

#### General data

Color	Green
Weight	215 g (with connectors)
Operating mode	Process data mode with 5 words/1 word PCP
Connection method for actuators	2-wire technology with shield connection
Ambient temperature (operation)	-40 °C ... +55°C (see also the "Tested successfully: Use under extreme ambient conditions" section of the data sheet).
Ambient temperature (storage/transport)	-40 °C ... +85°C
Temperature class	T2 (-40°C ... +55°C, IEC 50155)
Permissible humidity (operation/storage/transport)	10% to 95%, according to DIN EN 61131-2
Permissible air pressure (operation/storage/transport)	70 kPa ... 106 kPa (up to 3000 m above sea level)
Degree of protection	IP20
Protection class	III, IEC 61140, EN 61140, VDE 0140-1

#### Connection data

Designation	Inline connector
Connection method	Spring-cage connection
Conductor cross section, solid/stranded	0.08 mm <sup>2</sup> ... 1.5 mm <sup>2</sup>
Conductor cross section (AWG)	28 ... 16

#### Inline local bus interface

Connection method	Inline data jumper
Transmission speed	500 kbps

#### Power consumption

Communications power $U_L$	7.5 V DC
Current consumption from $U_L$	80 mA (typical)
I/O supply voltage $U_{ANA}$	24 V DC
Current consumption at $U_{ANA}$	72 mA (typical)
Total power consumption	2.35 W (typical)

#### Supply of the module electronics and I/O through bus coupler/power terminal

Connection method	Potential routing
-------------------	-------------------

**Analog outputs**

Number	Eight analog voltage outputs	
Connection of signals	2 or 3-wire, shielded twisted pair cable	
Signals	0 V to 10 V, 0 V to 5 V, ±10 V, ±5 V	
Output value representation	16 bits (15 bits with sign bit) or 8 bits (7 bits with sign bit)	
Resolution of the DAC	16 bits	
Resolution (quantization)	Inline format	
0 V to 10 V	0 V to 10.837 V	0.333 mV/LSB
0 V to 5 V	0 V to 5.419 V	0.167 mV/LSB
±10 V	-10.837 V to +10.837 V	0.333 mV/LSB
±5 V	-5.419 V to +5.419 V	0.167 mV/LSB
Basic error limit	Voltage: ±0.1% (typical) of the output range final value	
Output load	2 kΩ, minimum, 30 kΩ, typical	
Process data update including conversion time of the D/A converter	2 ms	
Slew rate (>99% of the final value)	< 1 ms at ohmic load	
Actuator cable length	250 m, maximum, using shielded cable 10 m, maximum, using unshielded cable	
Default		
Output range	±10 V	
Format	IB IL	
Behavior upon bus reset	HOLD (hold last value)	

**Protective equipment**

Transient protection of analog outputs	Yes
Short-circuit protection of analog outputs	Yes, for at least 1 minute

**Electrical isolation**

**Common potentials**

The 24 V main voltage  $U_M$ , 24 V segment voltage  $U_S$ , and GND have the same potential. FE is a separate potential area.

**Separate potentials in the terminal**

Test distance	Test voltage
7.5 V supply voltage/ ±15 V	500 V AC, 50 Hz, 1 min.
7.5 V supply voltage (bus logic)/functional earth ground	500 V AC, 50 Hz, 1 min.
±15 V-, +5 V analog supply (analog I/O)/functional earth ground	500 V AC, 50 Hz, 1 min.

**Error messages to the higher-level control or computer system**

Failure of the internal I/O voltage supply	Yes, I/O error message sent to the bus coupler
Failure of or insufficient communications power $U_L$	Yes, I/O error message sent to the bus coupler

**Signal rise times: voltage output 0 V to 10 V (typical values)**

	10% to 90%	0% to > 99% (including overshoots)
No-load operation	9 μs	20 μs
Ohmic load $R_L = 2 \text{ k}\Omega$	10 μs	22 μs
Ohmic/capacitive load $R_L = 2 \text{ k}\Omega$ / $C_L = 10 \text{ nF}$ (parallel)	9 μs	28 μs
Ohmic/capacitive load $R_L = 2 \text{ k}\Omega$ / $C_L = 220 \text{ nF}$ (parallel)	71 μs	175 μs
Ohmic/inductive load $R_L = 2 \text{ k}\Omega$ / $L_L = 3,3 \text{ mH}$ (serial)	9 μs	19 μs

**Signal rise times: voltage output 0 V to 5 V (typical values)**

	10% to 90%	0% to > 99% (including overshoots)
No-load operation	8 μs	18 μs
Ohmic load $R_L = 2\text{ k}\Omega$	9 μs	20 μs
Ohmic/capacitive load $R_L = 2\text{ k}\Omega$ / $C_L = 10\text{ nF}$ (parallel)	8 μs	26 μs
Ohmic/capacitive load $R_L = 2\text{ k}\Omega$ / $C_L = 220\text{ nF}$ (parallel)	29 μs	118 μs
Ohmic/inductive load $R_L = 2\text{ k}\Omega$ / $L_L = 3.3\text{ mH}$ (serial)	8 μs	20 μs

**Signal rise times: voltage output ±5 V (typical values)**

	10% to 90%	0% to > 99% (including overshoots)
No-load operation	9 μs	19 μs
Ohmic load $R_L = 2\text{ k}\Omega$	10 μs	20 μs
Ohmic/capacitive load $R_L = 2\text{ k}\Omega$ / $C_L = 10\text{ nF}$ (parallel)	9 μs	28 μs
Ohmic/capacitive load $R_L = 2\text{ k}\Omega$ / $C_L = 220\text{ nF}$ (parallel)	54 μs	150 μs
Ohmic/inductive load $R_L = 2\text{ k}\Omega$ / $L_L = 3.3\text{ mH}$ (serial)	9 μs	20 μs

**Signal rise times: voltage output ±10 V (typical values)**

	10% to 90%	0% to > 99% (including overshoots)
No-load operation	12 μs	24 μs
Ohmic load $R_L = 2\text{ k}\Omega$	13 μs	27 μs
Ohmic/capacitive load $R_L = 2\text{ k}\Omega$ / $C_L = 10\text{ nF}$ (parallel)	12 μs	32 μs
Ohmic/capacitive load $R_L = 2\text{ k}\Omega$ / $C_L = 220\text{ nF}$ (parallel)	117 μs	220 μs
Ohmic/inductive load $R_L = 2\text{ k}\Omega$ / $L_L = 3.3\text{ mH}$ (serial)	12 μs	24 μs

**Programming data**

Local bus (INTERBUS)

ID code	DF <sub>hex</sub> (223 <sub>dec</sub> )
Length code	05 <sub>hex</sub>
Input address area	5 words
Output address area	5 words
Parameter channel (PCP)	1 words
Register length (bus)	6 words



For the programming data/configuration data of other bus systems, please refer to the corresponding electronic device data sheet (e.g., GSD, EDS).

**Approvals**

For the latest approvals, please visit [www.phoenixcontact.net/catalog](http://www.phoenixcontact.net/catalog).

## 4 Tolerance and temperature response



All percentage tolerance values refer to the relevant measuring range final value. Unless stated otherwise, nominal operation (nominal voltage, preferred mounting position, default format, identical measuring range setting for channels) is used as the basis. The tolerance values refer to the operating temperature range specified in the tables. The operable range outside this range is not taken into consideration. Please also observe the tolerances under influences of electromagnetic interference.

The maximum tolerance values represent the worst case measurement inaccuracy. They contain the theoretical maximum possible tolerances in the output range sections measuring ranges as well as the theoretical maximum possible tolerances of the calibration and test equipment.

### Tolerance and temperature response

The tolerance values refer to the measuring range final value at a typical load (30 k $\Omega$ ).

#### T<sub>A</sub> = 25°C

Output range	Absolute (typical)	Absolute (maximum)	Relative (typical)	Relative (maximum)
0 V to 5 V, $\pm 5$ V	$\pm 18$ mV	$\pm 25$ mV	$\pm 0.36\%$	$\pm 0.50\%$
0 V to 10 V, $\pm 10$ V	$\pm 19$ mV	$\pm 25$ mV	$\pm 0.19\%$	$\pm 0.25\%$

T<sub>A</sub> = -25°C...+55°C

Output range	Absolute (typical)	Absolute (maximum)	Relative (typical)	Relative (maximum)
0 V to 5 V, $\pm 5$ V	$\pm 22$ mV	$\pm 40$ mV	$\pm 0.44\%$	$\pm 0.80\%$
0 V to 10 V, $\pm 10$ V	$\pm 26$ mV	$\pm 40$ mV	$\pm 0.26\%$	$\pm 0.40\%$

### Additional tolerances influenced by electromagnetic fields

Type of electromagnetic interference	Typical deviation of the output range final value (relative)
Electromagnetic fields; field strength 10 V/m according to EN 61000-4-3/IEC 61000-4-3	< $\pm 0.5\%$
Conducted interference Class 3 (test voltage 10 V) according to EN 61000-4-6/IEC 61000-4-6	< $\pm 0.5\%$
Fast transients (burst), 4 kV supply, 2 kV input according to EN 61000-4-4/IEC 61000-4-4	< $\pm 0.5\%$

## 5 Tested successfully: Use under extreme ambient conditions

The terminal has been tested successfully over 250 temperature change cycles in accordance with IEC 61131-2 in the range from  $-40^{\circ}\text{C}$  to  $+70^{\circ}\text{C}$ .

The following conditions were observed:

- The Inline devices for all connecting cables were connected with a minimum conductor cross section of  $0.5\text{ mm}^2$
- The Inline station was installed on a wall-mounted horizontal DIN rail
- Fans were used to ensure continuous movement of air in the control cabinet
- The Inline station was not exposed to vibration or shock
- The Inline station was operated with a maximum of  $24.5\text{ V}$  (ensured by using regulated power supply units)

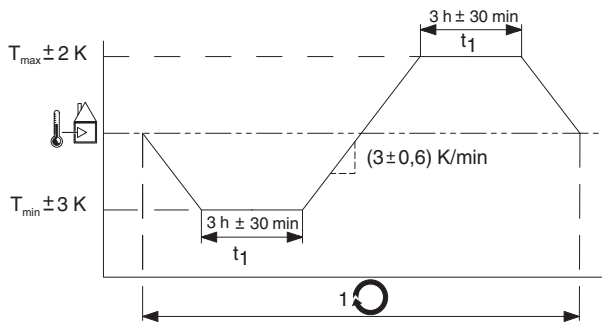

Figure 1 Temperature change cycle



Temperature in the control cabinet/ambient temperature



Cycle



**WARNING:**

The terminal is not approved for use in potentially explosive areas.

The terminal is not approved for use in safety technology.



### 6 Internal basic circuit diagram

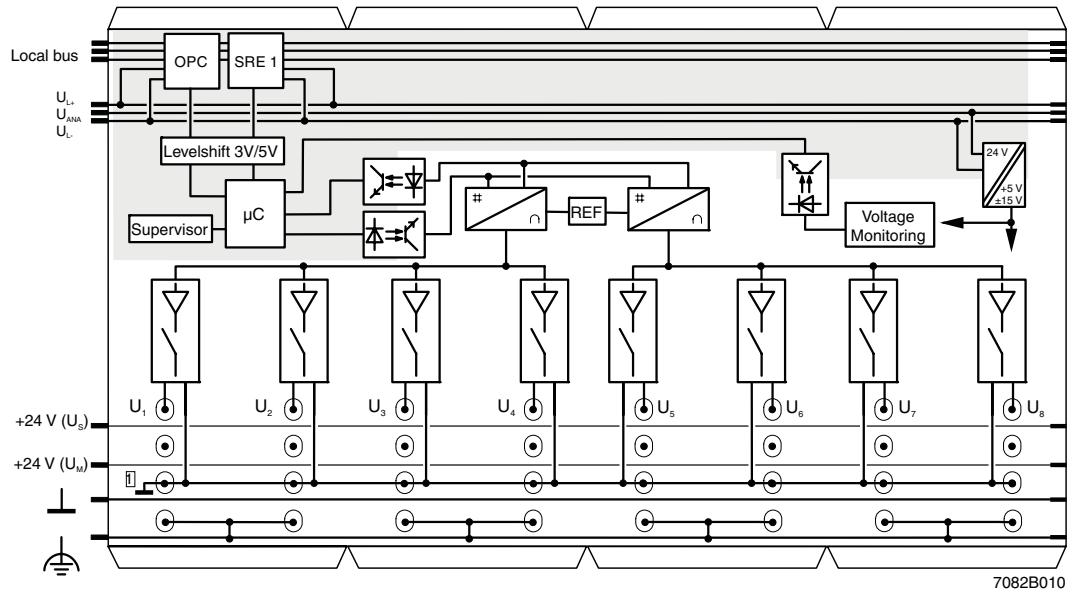















Figure 2 Internal wiring of the terminal points

Key:

-  Protocol chip
  -  Register expansion
  -  Level adaptation
  -  Hardware monitoring
  -  Microcontroller
  -  Optocoupler
  -  Digital/analog converter
  -  Reference voltage
  -  Output level
  -  Voltage monitoring
  -  DC/DC converter with electrical isolation
  -  Analog ground, electrically isolated from potential jumper ground
-  Other symbols used are explained in the IL SYS INST UM E user manual.

**7 Electrical isolation**

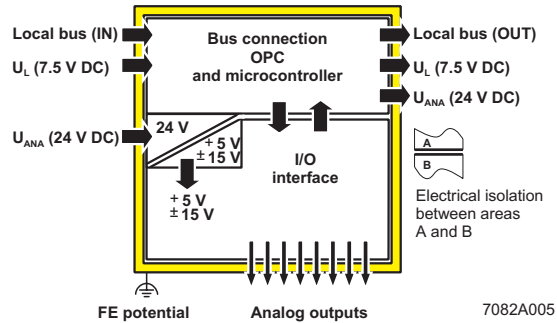

Figure 3 Electrical isolation of the individual function areas

**8 Local diagnostic indicators**

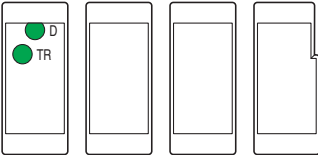

Figure 4 Local diagnostic indicators

Des.	Color	Meaning
D	Green	Diagnostics
TR	Green	PCP active

**Function identification**

Yellow

**9 Terminal point assignment for each connector**

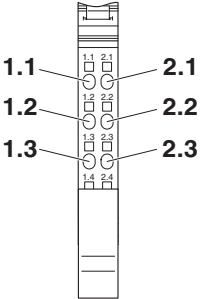

Figure 5 Terminal point assignment

Terminal points	Signal	Assignment
1.1	U <sub>1</sub>	Voltage output 1
2.1	U <sub>2</sub>	Voltage output 2
1.2, 2.2	-	Not used
1.3, 2.3	AGND	Ground of voltage outputs
1.4, 2.4	Shield	Shield connection

## 10 Installation instructions

High current flowing through potential jumpers  $U_M$  and  $U_S$  leads to a temperature rise in the potential jumpers and inside the terminal. To keep the current flowing through the potential jumpers of the analog terminals as low as possible, always place the analog terminals after all the other terminals at the end of the main circuit (for the sequence of the In-line terminals: see also IL SYS INST UM E user manual).

## 11 Connection notes



Analog actuators with a cable length of **< 10 m** can be connected using unshielded twisted-pair cables.



Connect analog actuators with a cable length of **> 10 m** using shielded twisted-pair cables. At the terminal, connect one end of the shielding to PE. Fold the outer cable sheath back and connect the shield to the terminal via the shield connector clamp (with strain relief). The clamp connects the shield directly to FE on the terminal side.



Ensure that the braided shield is 15 mm longer than the strain relief when connecting a shielded actuator cable to the I/O connector. Connect the actuator cables as described in “Connecting shielded cables using the shield connector” on page 12.

## 12 Connection example



Use a connector with shield connection when installing the actuators. Figure 6 shows the connection schematically (without shield connector).

Connecting actuators

Slot	1	2	3	4
Channel	1 2	3 4	5 6	7 8

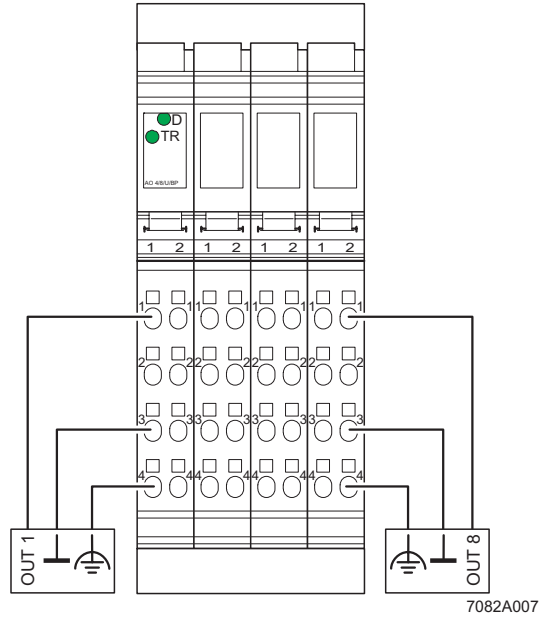

Figure 6 Connecting two actuators

### 13 Connecting shielded cables using the shield connector

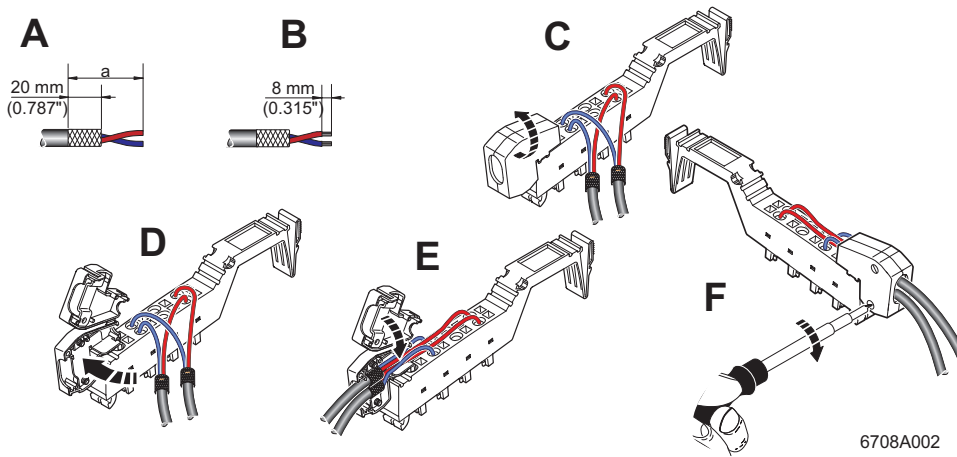

Figure 7 Connecting the shield using the shield connector



The diameter of the actuator cable is usually too large to allow the cables to be inserted into the strain relief of the shield connector with sheathed and folded shield. The connection procedure for this cable therefore differs from the connection procedure described in the user manual. The differences from the user manual are marked in bold text.

When connecting the cables, proceed as shown in Figure 7:

#### Stripping cables

- Strip the outer cable sheaths to the desired length (a). (A)  
The desired length (a) depends on the connection position of the wires and whether the wires should have a large or small amount of space between the connection point and the shield connection.
- Shorten the braided shield to **20 mm** (A).
- Do **not** fold the braided shield back over the outer sheath. (B)
- Remove the protective foil.
- Strip 8 mm off the wires. (B)



Inline wiring is normally without ferrules. However, it is possible to use ferrules. If you are using ferrules, make sure they are properly crimped.

**Wiring connectors  
(according to the user manual)**

- Push a screwdriver into the actuation shaft of the appropriate terminal point, so that you can insert the wire into the spring opening.  
Phoenix Contact recommends the screwdriver SZF 1-0,6X3,5 (Order. No. 1204517).
- Insert the wire. Remove the screwdriver from the opening. This clamps the wire.

The connector pin assignment can be found in the table on page 10.

- Insert the shield connection clamp in the shield connection according to the cable width (see user manual).
- Place the cables in the shield connection. (D)  
**Push the outer cable sheaths up to the shield connection clamp. The wires with the braided shield must be underneath the shield connection clamp. The braided shield must project approximately 15 mm over the shield connection clamp.**
- Close the shield connection. (E)
- Tighten the screws on the shield connection with a screwdriver. (F)

**Connecting the shield**

- Open the shield connection (see user manual). (C)

**14 Process data**

The device has five process data words and one PCP word.

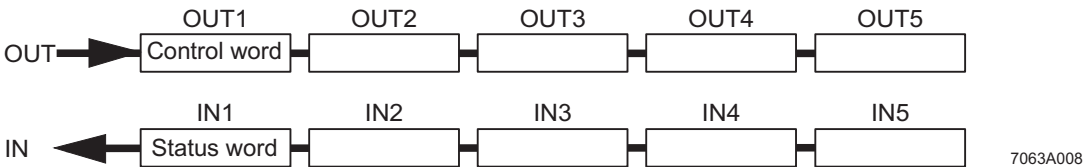

Figure 8 Order of the process data words

**15 OUT process data**

Five process data output words are available.

Configure the terminal channels via the OUT1 process data word.

If you change the configuration the corresponding channel is re-initialized. If the configuration is invalid, a corresponding error message is output in the status word. The configuration settings are stored in a volatile memory only.

15.1 Output word OUT1 (control word)

	OUT1															
Bit	15	14	13	12	11	10	9	8	7	6	5	4	3	2	1	0
Assignment	Command code				Channel/output				0	0	0	0	0	0	0	0

Bit 15 to bit 8 (command code and channel/output):

Bit 15 to bit 12	Bit 11 to bit 8	OUT1	Command function
0 0 0 0	0 0 0 0	0000 <sub>hex</sub>	All outputs are disabled
0 0 0 0	0 0 0 1	0100 <sub>hex</sub>	Output at channels 1 to 4
0 0 0 0	1 0 0 1	0900 <sub>hex</sub>	Output at channels 5 to 8
0 0 0 1	0 <b>C</b> <b>C</b> <b>C</b>	1x00 <sub>hex</sub>	Read configuration in IN2 channel-by-channel.
0 0 1 1	1 1 0 0	3C00 <sub>hex</sub>	Read firmware version and module ID in IN2.
0 1 0 0	0 <b>C</b> <b>C</b> <b>C</b>	4xyy <sub>hex</sub>	Configure channel
0 1 0 1	0 0 0 1	5100 <sub>hex</sub>	Output at channels 1 to 8 in 8-bit resolution
0 1 1 0	0 0 0 0	60yy <sub>hex</sub>	Configure entire terminal (all channels)

CCC = Channel number; CCC = 000: Channel 1; CCC = 111: Channel 8; yy = Parameter for configuration

Control word assignment with command code 0<sub>hex</sub>

	OUT1															
Bit	15	14	13	12	11	10	9	8	7	6	5	4	3	2	1	0
Assignment	0	0	0	0	<b>Gr</b>	0	<b>Z</b>	<b>FAO</b>	0	0	0	0	0	0	0	0

0	All outputs disabled
1	Outputs are set to the value specified last

0	Output value directly; the buffered values for the channels that are not addressed are also output
1	Buffer value only

0 Channels 1 to 4  
1 Channels 5 to 8

- Gr Group
- Z Buffering action
- FAO Enabling the analog output channels

Output word assignment with command "Output at channels 1 to 8 in 8-bit resolution"

Word	OUT 1		OUT 2		OUT 3		OUT 4		OUT 5	
Byte	1	2	3	4	5	6	7	8	9	10
	5100 <sub>hex</sub>		Chan- nel 1	Chan- nel 2	Chan- nel 3	Chan- nel 4	Chan- nel 5	Chan- nel 6	Chan- nel 7	Chan- nel 8

### 15.2 Parameters in output word OUT1

For command  $4xyy_{hex}$  and  $60yy_{hex}$  the parameters must be specified in OUT1 in addition to the command code. The parameters are only evaluated for these commands.

Bit	OUT1														
	15	14	13	12	11	10	9	8	7	6	5	4	3	2	1
4xyy assignment	0	1	0	0	0	K	K	K	0	AV	Format	Output range			
60yy assignment	0	1	1	0	0	0	0	0	0	AV	Format	Output range			

- AV                      Output behavior during bus reset
- Format                Representation of the output value in the OUT process data
- Output range         Output range settings

 If invalid parameters are specified in the parameter word, the command will not be executed. The command is confirmed in the input words with the set error bit.

### 15.3 Parameters for configuration

The values displayed in bold are default settings.

Bit 6:

Code		Output behavior during bus reset
Dec	Bin	
<b>0</b>	<b>0</b>	<b>Hold</b>
1	1	Reset

Bit 5 and bit 4

Code		Format
Dec	Bin	
<b>0</b>	<b>00</b>	<b>IB IL format (15 bits + sign bit with extended diagnostics)</b>
1	01	IB ST format (12 bits + sign bit + 3 diagnostic bits)
2	10	S7-compatible format (15 bits + sign bit)
3	11	Standardized representation format

Bit 3 to bit 0:

Code		Output range
Dec	Bin	
0	0000	0 V to 10 V
<b>1</b>	<b>0001</b>	<b>±10 V</b>
2	0010	0 V to 5 V
3	0011	±5 V
4	0100	Reserved
...	...	
15	1111	

## 16 IN process data

### 16.1 Input word IN1 (status word)

Five IN process data words are available.

The input word IN1 serves as status word.

		IN1															
Bit		15	14	13	12	11	10	9	8	7	6	5	4	3	2	1	0
Assignment	EB	Bits 14 to 8 of the control word are mirrored							0	0	0	0	0	0	0	0	0

#### EB: Error bit

EB = 0 No error has occurred.

EB = 1 An error has occurred.

#### Mirroring of the command code:

A command code mirrored from the control word. Here, the MSB is suppressed.

### 16.2 Input words IN2 to IN5

The mirrored output words, the configuration or the firmware version are transmitted to the controller board or the PC via the process data input words IN2 up to IN5 in accordance with the configuration.

For control word **3C00<sub>hex</sub>**, IN2 provides the firmware version and the module ID.

#### Example: firmware version 1.23:

		IN2															
Bit		15	14	13	12	11	10	9	8	7	6	5	4	3	2	1	0
Assignment (hex)		1				2				3				4 <sub>hex</sub>			
Meaning		Firmware version 1.23												Module ID			



## 17 Formats for representing output values

### 17.1 IB IL format (default setting)

The output value is represented in bits 14 to 0. An additional bit (bit 15) is available as a sign bit.

Output value representation in IB IL format; 15 bits

MSB														LSB	
15	14	13	12	11	10	9	8	7	6	5	4	3	2	1	0
SB	Analog value														

SB Sign bit

### Typical analog values depending on the output range

INTERBUS output word		0 V to 10 V	+/-10 V	0 V to 5 V	+/- 5 V
[hex]	[dec]	$U_{\text{Output}}$ [V]	$U_{\text{Output}}$ [V]	$U_{\text{Output}}$ [V]	$U_{\text{Output}}$ [V]
≤7FFF	≤32767	+10.837	+10.837	+5.419	+5.419
7F00	32512	+10.837	+10.837	+5.419	+5.419
7530	30000	+10.0	+10.0	+5.0	+5.0
0001	1	+333.33 μ	+333.33 μ	+166.67 μ	+166.67 μ
0000	0	≤0	0	≤0	0
FFFF	-1	0	-333.33 μ	0	-166.67 μ
8AD0	-30000	0	-10.0	0	-5.0
8100	-32512	0	-10.837	0	-5.419
80FF to 8000 (without 8001 and 8080)	-32768...-32513	HOLD	HOLD	HOLD	HOLD
8001	-32767 Ovrange	+10.837	+10.837	+5.419	+5.419
8080	-32640 Underrange	0	-10.837	0	-5.419

**17.2 IB ST format**

The output value is represented in bits 14 to 3. The remaining 4 bits are available as sign and error bits.

Output value representation in IB ST format; 12 bits

MSB													LSB		
15	14	13	12	11	10	9	8	7	6	5	4	3	2	1	0
SB	Analog value												0	0	0

- SB Sign bit
- 0 Reserved

**Typical analog values depending on the output range**

INTERBUS output word		0 V to 10 V	+/-10 V	0 V to 5 V	+/- 5 V
[hex]	[dec]	$U_{Output}$ [V]	$U_{Output}$ [V]	$U_{Output}$ [V]	$U_{Output}$ [V]
≤7FFF	32767	9.9976	9.9976	4.9988	4.9988
7FF8	32760	9.9976	9.9976	4.9988	4.9988
4000	16384	5.00	5.00	2.50	2.50
0008	8	0.002441	0.002441	0.001221	0.001221
0000	0	0	0	0	0
FFF8	-8	0	-0.002441	0	-0.001221
C000	-16384	0	-5.0000	0	-2.5000
8008	-32760	0	-9.9976	0	-4.9988
≥8000	-32768	0	-9.9976	0	-4.9988

**17.3 S7-compatible format**

The output value is represented in bits 14 to 0. An additional bit (bit 15) is available as a sign bit.

Output value representation in the format compatible with S7 (15 bits)

MSB														LSB	
15	14	13	12	11	10	9	8	7	6	5	4	3	2	1	0
SB	Analog value														

SB Sign bit

**Typical analog values depending on the output range**

INTERBUS output word		0 V to 10 V	+/-10 V	0 V to 5 V	+/- 5 V
[hex]	[dec]	U <sub>Output</sub> [V]	U <sub>Output</sub> [V]	U <sub>Output</sub> [V]	U <sub>Output</sub> [V]
≤7FFF	≤32767	0	0	0	0
7F00	32512	0	0	0	0
7EFF	32511	+11.7589	+11.7589	+5.88	+5.88
6C01	27649	+10.0004	+10.0004	+5.0002	+5.0002
6C00	27648	+10.0000	+10.0000	+5.0000	+5.0000
5100	20736	+7.5000	+7.5000	+3.7500	+3.7500
1	1	+361.69 μ	+361.69 μ	+180.845 μ	+180.845 μ
0	0	0	0	0	0
FFFF	-1	0	-361.69 μ	0	-180.845 μ
E501	-6911	0	-2.4996	0	-1.2498
E500	-6912	0	-2.5000	0	-1.2500
AF00	-20736	0	-7.5000	0	-3.7500
9400	-27648	0	-10.0000	0	-5.0000
93FF	-27649	0	-10.0004	0	-5.0002
8101	-32511	0	-11.7589	0	-5.8800
8000 to 8100	-32768 to -32512	0	0	0	0

**17.4 “Standardized representation” format**

The output value is represented in bits 14 to 0. An additional bit (bit 15) is available as a sign bit.

Output value representation in “standardized representation” format (15 bits)

MSB	15	14	13	12	11	10	9	8	7	6	5	4	3	2	1	0	LSB
SB	Analog value																

SB Sign bit

**Typical analog values depending on the output range**

INTERBUS output word		0 V to 10 V	+/-10 V	0 V to 5 V	+/- 5 V
[hex]	[dec]	U <sub>Output</sub> [V]	U <sub>Output</sub> [V]	U <sub>Output</sub> [V]	U <sub>Output</sub> [V]
2A56 to 7FFF	10838 to 32767	+10.837	+10.837	+5.419	+5.419
2A55	10837	<b>+10.837</b>	<b>+10.837</b>	+5.419	+5.419
2710	10000	+10.0	+10.0	+5.419	+5.419
152B	5419	+5.419	+5.419	<b>+5.419</b>	<b>+5.419</b>
1388	5000	+5.0	+5.0	+5.0	+5.0
0001	1	+0.001	+0.001	+0.001	+0.001
0000	0	0	0	0	0
FFFF	-1	0	-0.001	0	-0.001
EC78	-5000	0	-5.0	0	-5.0
EAD5	-5419	0	-5.419	0	<b>-5.419</b>
D8F0	-10000	0	-10.0	0	-5.419
D5AB	-10837	0	<b>-10.837</b>	0	-5.419
D5AA to 8100	-10838 to -32512	0	-10.837	0	-5.419
80FF to 8000 (without 8001 and 8080)	-32768 to -32513	HOLD	HOLD	HOLD	HOLD
8001	-32767 Overrange	+10.837	+10.837	+5.419	+5.419
8080	-32640 Underrange	0	-10.837	0	-5.419

## 18 Configuration and analog value transmission

You can configure the terminal **either** via process data or via PCP and transmit the analog values accordingly.

### Example for terminal configuration via process data

All channels are to hold their value (HOLD), use the IB IL format and output the values in the range 0 V to 5 V. Therefore the parameter value is 0002<sub>hex</sub>.

Step	Process data	Meaning
1	OUT1 = 6002 <sub>hex</sub>	Specify configuration
2	Wait until IN1 = 6002 <sub>hex</sub>	Wait for confirmation
3	Analog value OUT2 = Channel 1, ..., OUT5 = Channel 4 OUT1 = 0100 <sub>hex</sub>	Analog value output at channels 1 to 4
4	Wait until IN1 = 0100 <sub>hex</sub>	Wait for confirmation
5	Analog value OUT2 = Channel 5, ..., OUT5 = Channel 8 OUT1 = 0900 <sub>hex</sub>	Analog value output at channels 5 to 8
6	Wait until IN1 = 0900 <sub>hex</sub>	Wait for confirmation



Secure process data transmission requires process data consistency of five words.

In the event that consistency of five words cannot be ensured, an intermediate step is recommended after every output command. The buffer bit in the “Write analog values” command is used for this purpose. As a result, step 3 and step 5 become more complicated:

Step	Process data	Meaning
1	OUT1 = 6002 <sub>hex</sub>	Specify configuration
2	Wait until IN1 = 6002 <sub>hex</sub>	Wait for confirmation
3a	OUT1 = 0300 <sub>hex</sub>	Buffer command
3b	Wait until IN1 = 0300 <sub>hex</sub>	Wait for confirmation
3c	OUT2 = analog value of channel 1 OUT3 = analog value of channel 2 OUT4 = analog value of channel 3 OUT5 = analog value of channel 4	Buffer the analog values for channels 1 to 4
3d	OUT1 = 0100 <sub>hex</sub>	Output the analog values for channels 1 to 4
4	Wait until IN1 = 0100 <sub>hex</sub>	Wait for confirmation
5a	OUT1 = 0B00 <sub>hex</sub>	Buffer command
5b	Wait until IN1 = 0B00 <sub>hex</sub>	Wait for confirmation
5c	OUT2 = analog value of channel 5 OUT3 = analog value of channel 6 OUT4 = analog value of channel 7 OUT5 = analog value of channel 8	Buffer the analog values for channels 5 to 8
5d	OUT1 = 0900 <sub>hex</sub>	Output the analog values for channels 5 to 8
6	Wait until IN1 = 0900 <sub>hex</sub>	Wait for confirmation

## 19 PCP communication



For information on PCP communication, please refer to the IBS SYS PCP G4 UM E (Order No. 2745169) and IBS PCP COMPACT UM E (Order No. 9015349) user manuals.

By default upon delivery, the terminal is configured according to the default settings on page 15. The terminal can be configured to suit your application using process data or PCP.

In PCP mode, the terminal is configured with the “Config Table” object.



The IBS CMD (for standard controller boards) and PC Worx (for Field Controllers (FC) and Remote Field Controllers (RFC)) programs are available for the configuration and parameterization of your INTERBUS system. Please refer to the corresponding documentation for more information.

### 19.1 Object dictionary

Index	Data type	N	L	Meaning	Object name	Rights
0080 <sub>hex</sub>	Array of Unsigned 16	10	2	Terminal configuration	Config Table	rd/wr
0085 <sub>hex</sub>	Array of Unsigned 16	8	2	Analog values of the channels	Analog Out Values	rd/wr

N: Number of elements

rd: Read access permitted

L: Length of an element in bytes

wr: Write access permitted

**19.2 Object descriptions**

**Config Table object**

Configure the terminal using this object.

**Object description:**

Object	Config Table	
Access	Read, Write	
Data type	Array of Unsigned 16	10 x 2 bytes
Index	0080 <sub>hex</sub>	
Subindex	00 <sub>hex</sub>	Write all elements
	01 <sub>hex</sub>	Configuration of channel 1
	02 <sub>hex</sub>	Configuration of channel 2
	03 <sub>hex</sub>	Configuration of channel 3
	04 <sub>hex</sub>	Configuration of channel 4
	05 <sub>hex</sub>	Configuration of channel 5
	06 <sub>hex</sub>	Configuration of channel 6
	07 <sub>hex</sub>	Configuration of channel 7
	08 <sub>hex</sub>	Configuration of channel 8
	09 <sub>hex</sub>	System settings
	0A <sub>hex</sub>	Reserved
Length (bytes)	14 <sub>hex</sub>	Subindex 00 <sub>hex</sub>
	02 <sub>hex</sub>	Subindex 01 <sub>hex</sub> to 0A <sub>hex</sub>
Data	Terminal configuration	

**Element value range**

The “**Configuration channel x**” elements have the following structure:

Bit	15	14	13	12	11	10	9	8	7	6	5	4	3	2	1	0
Assignment	0	0	0	0	0	0	0	0	0	AV	Format	Output range				

For the value ranges of the individual parameters, please refer to “Parameters for configuration” on page 15.

If an invalid configuration is specified, a negative confirmation is generated with error message 08<sub>hex</sub>, 00<sub>hex</sub> or xx30<sub>hex</sub>. The low byte of the additional error code is 30<sub>hex</sub> (value is out of range), the high byte contains the number of the affected element.

**Example:** Config Table is completely filled with data (subindex 00) and the entry for channel 6 is invalid. In this case, the additional error code equals 0630<sub>hex</sub>.

**Additional functions in element 9 (system settings):**

0001<sub>hex</sub>: Configuration via process data not locked

0002<sub>hex</sub>: Writing of the “Analog Out Values” object is permitted.

**Analog Out Values object**

The elements of this object contain the analog values of the channels in a format that has been selected for this channel.

Writing to this object must be enabled in the Config Table object. Write value 0002<sub>hex</sub> to subindex 09 in the “Config Table” object for this purpose.

**Object description:**

Object	Analog Values	
Access	Read/Write	
Data type	Array of Unsigned 16	8 x 2 bytes
Index	0085 <sub>hex</sub>	
Subindex	00 <sub>hex</sub>	Read/write all elements
	01 <sub>hex</sub>	Analog value of channel 1
	02 <sub>hex</sub>	Analog value of channel 2
	03 <sub>hex</sub>	Analog value of channel 3
	04 <sub>hex</sub>	Analog value of channel 4
	05 <sub>hex</sub>	Analog value of channel 5
	06 <sub>hex</sub>	Analog value of channel 6
	07 <sub>hex</sub>	Analog value of channel 7
	08 <sub>hex</sub>	Analog value of channel 8
Length (bytes)	10 <sub>hex</sub>	Subindex 00 <sub>hex</sub>
	02 <sub>hex</sub>	Subindex 01 <sub>hex</sub> to 08 <sub>hex</sub>
Data	Analog values of the channels	



Компания «Океан Электроники» предлагает заключение долгосрочных отношений при поставках импортных электронных компонентов на взаимовыгодных условиях!

Наши преимущества:

- Поставка оригинальных импортных электронных компонентов напрямую с производств Америки, Европы и Азии, а так же с крупнейших складов мира;
- Широкая линейка поставок активных и пассивных импортных электронных компонентов (более 30 млн. наименований);
- Поставка сложных, дефицитных, либо снятых с производства позиций;
- Оперативные сроки поставки под заказ (от 5 рабочих дней);
- Экспресс доставка в любую точку России;
- Помощь Конструкторского Отдела и консультации квалифицированных инженеров;
- Техническая поддержка проекта, помощь в подборе аналогов, поставка прототипов;
- Поставка электронных компонентов под контролем ВП;
- Система менеджмента качества сертифицирована по Международному стандарту ISO 9001;
- При необходимости вся продукция военного и аэрокосмического назначения проходит испытания и сертификацию в лаборатории (по согласованию с заказчиком);
- Поставка специализированных компонентов военного и аэрокосмического уровня качества (Xilinx, Altera, Analog Devices, Intersil, Interpoint, Microsemi, Actel, Aeroflex, Peregrine, VPT, Syfer, Eurofarad, Texas Instruments, MS Kennedy, Miteq, Cobham, E2V, MA-COM, Hittite, Mini-Circuits, General Dynamics и др.);

Компания «Океан Электроники» является официальным дистрибьютором и эксклюзивным представителем в России одного из крупнейших производителей разъемов военного и аэрокосмического назначения «**JONHON**», а так же официальным дистрибьютором и эксклюзивным представителем в России производителя высокотехнологичных и надежных решений для передачи СВЧ сигналов «**FORSTAR**».



## JONHON

«**JONHON**» (основан в 1970 г.)

Разъемы специального, военного и аэрокосмического назначения:

(Применяются в военной, авиационной, аэрокосмической, морской, железнодорожной, горно- и нефтедобывающей отраслях промышленности)

«**FORSTAR**» (основан в 1998 г.)

ВЧ соединители, коаксиальные кабели, кабельные сборки и микроволновые компоненты:

(Применяются в телекоммуникациях гражданского и специального назначения, в средствах связи, РЛС, а так же военной, авиационной и аэрокосмической отраслях промышленности).



Телефон: 8 (812) 309-75-97 (многоканальный)

Факс: 8 (812) 320-03-32

Электронная почта: [ocean@oceanchips.ru](mailto:ocean@oceanchips.ru)

Web: <http://oceanchips.ru/>

Адрес: 198099, г. Санкт-Петербург, ул. Калинина, д. 2, корп. 4, лит. А