

# General Specifications

## Electrical Capacity (Resistive Load)

**Low/Logic Level:** 50mA @ 24V DC maximum

## Other Ratings

**Contact Resistance:** 100 milliohms maximum

**Insulation Resistance:** 100 megohms minimum @ 250V DC

**Dielectric Strength:** 250V AC minimum between contacts & between contacts & case for 1 minute minimum

**Mechanical Life:** 100,000 operations minimum

**Electrical Life:** 100,000 operations minimum

**Nominal Operating Force:** 1.57N

**Total Travel:** .010" (.250mm)

## Materials & Finishes

**Actuator:** Glass fiber reinforced polyamide (UL94V-0)

**Case:** Stainless steel

**Seal:** Polytetrafluoroethylene

**Base:** Polyphthalamide (UL94V-0)

**Movable Contacts:** Beryllium copper with silver plating

**Stationary Contacts:** Brass with silver plating

**Terminals:** Brass with silver plating

## Environmental Data

**Operating Temperature Range:** -25°C through +70°C (-13°F through +158°F)

**Humidity:** 90 ~ 95% humidity for 96 hours @ 40°C (104°F)

**Vibration:** 10 ~ 55Hz with peak-to-peak amplitude of 1.5mm traversing the frequency range & returning in 1 minute; 3 right angled directions for 2 hours

**Shock:** 50G (490m/s<sup>2</sup>) acceleration (tested in 6 right angled directions, with 5 shocks in each direction)

## Processing

**Soldering:** Reflow Soldering Recommended. See Profile A in Supplement section.

Manual Soldering: See Profile A in Supplement section.

**Cleaning:** Automated cleaning. See Cleaning Specifications in Supplement section.

## Standards & Certifications

**Flammability Standards:** UL94V-0 actuator & base

The CB3 Series tactiles have not been tested for UL recognition or CSA certification.

These switches are designed for use in a low-voltage, low-current, logic-level circuit.

When used as intended in a logic-level circuit, the results do not produce hazardous energy.

# Distinctive Characteristics

Sealed construction prevents contact contamination and allows automated soldering and cleaning.

.244" (6.2mm) square body allows compact mounting.

Heat tolerant resin used for actuator and base meets UL flammability rating of 94V-0 and maintains switch reliability through vapor phase and infrared convection reflow soldering.

Dome contact gives crisp tactile feedback to positively indicate circuit transfer and assures high reliability and long life – more than 100,000 operations.

Gull-winged terminals ensure mechanical stability during soldering and simplify solder joint inspection.

Insert molded terminals lock out flux, solvents, and other contaminants.

Packaged in tape-reel or partitioned tray. Tape-reel packaging meets EIA-481-D Standard.

Coplanarity: all considered surfaces must lie between two parallel planes that are a maximum distance apart of .0059" (0.15mm). (Additional coplanarity details in Terms and Acronyms in the Supplement section.)

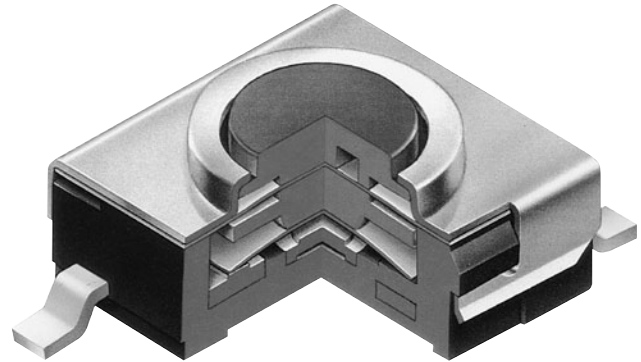

Actual Size

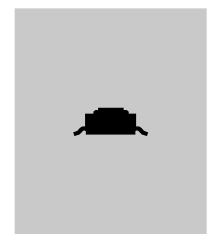

### TYPICAL SWITCH ORDERING EXAMPLE

Ordering Example: **CB3** - **15** - **F** - **P** - **□**

Pole & Circuit			
15	SPST	OFF	(ON)
( ) = Momentary			

Actuator	
F	Flat Button

Terminals	
P	Gull Wing for Upright Mount

Packaging	
R	Tape-Reel 1,000 Pieces/Reel
No Code	Partitioned Tray

### DESCRIPTION FOR TYPICAL ORDERING EXAMPLE

**CB315FP**



### POLE & CIRCUIT

Pole	Model	Actuator Position ( ) = Momentary		Switch Throw & Schematic	Note: Terminal numbers are not actually on switch.
		Normal	Down		
SP	CB315	OFF	(ON)	SPST 	

### TYPICAL SWITCH DIMENSIONS

#### Single Pole • Single Throw

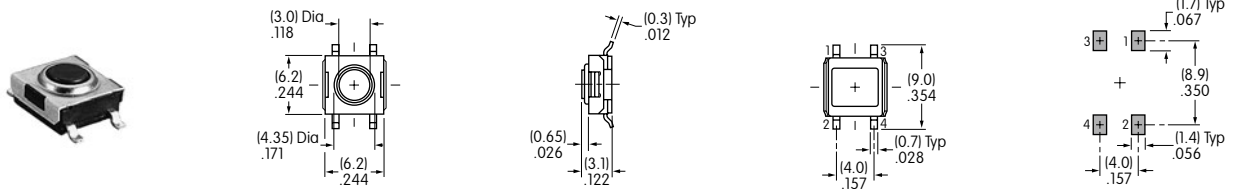

**CB315FP**

Toggles  
Rockers  
Pushbuttons  
Illuminated PB  
Programmable  
Keylocks  
Rotaries  
Slides  
Tactiles  
Tilt  
Touch  
Indicators  
Accessories  
Supplement

## PACKAGING

**R**

### Tape-Reel (packaged to EIA-481-D standard)

Switches must be ordered in 1,000-piece increments when tape-reel packaging is selected.

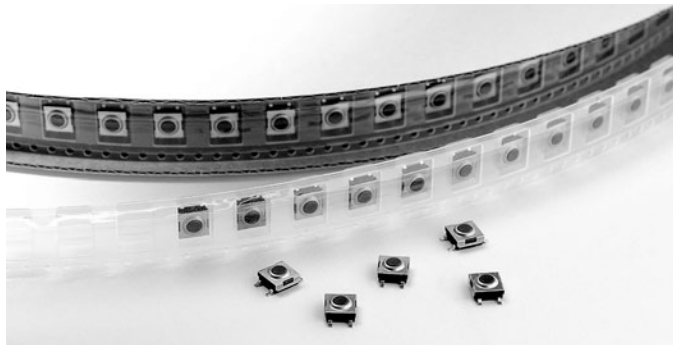

**No Code**

### Partitioned Tray

If less than 1,000 pieces are ordered, the switches are packaged in a partitioned tray. No code is required.

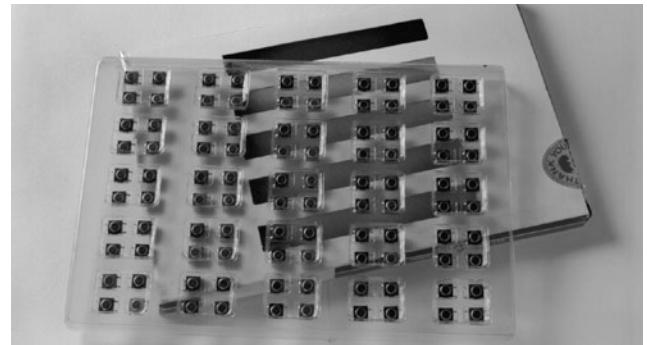

### Tape-Reel Dimensions & Specifications

Each tape-reel of 1,050 pockets contains 1,000 switches

Minimum Leader Length: 16.54" (420mm) Minimum Trailer Length: 7.09" (180mm)

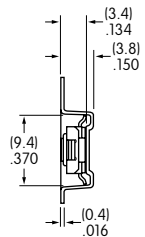
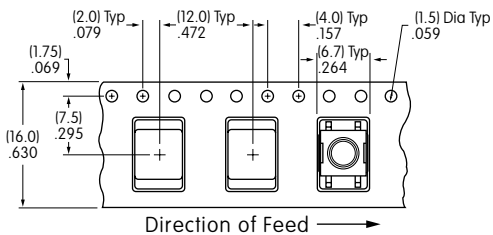
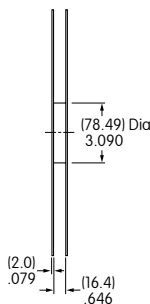
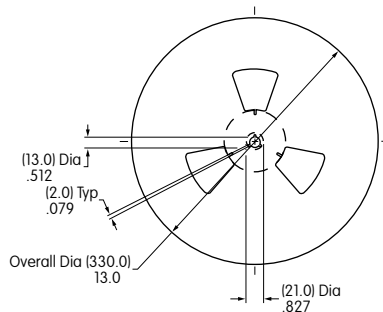

## KEYBOARD MATRIX

### Common Bus Matrix

These single pole, single throw switches can be used in a keyboard matrix and, using strapped terminals, achieve a common bus electrical configuration on a single-sided PC board.

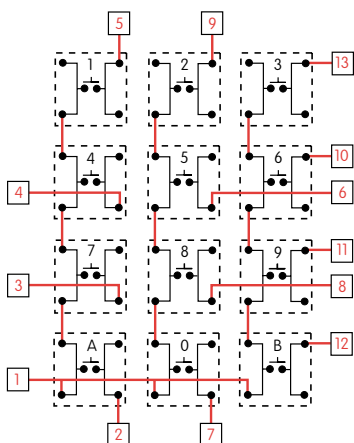

		PC Terminations												
		1	2	3	4	5	6	7	8	9	10	11	12	13
Keys (Switches)	1													
	2													
	3													
	4													
	5													
	6													
	7													
	8													
	9													
	0													
	A													
	B													

● = ON

### X-Y Matrix

These single pole, single throw switches can be arranged on a single-sided PC board matrix with strapped terminals to achieve an X-Y type electrical interconnection.

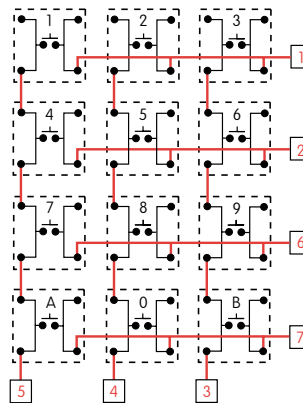

		PC Terminations						
		1	2	3	4	5	6	7
Keys (Switches)	1							
	2							
	3							
	4							
	5							
	6							
	7							
	0							
	A							
	B							

● = ON

Red = PCB Trace    Black = Switch Circuit

Toggles  
Rockers  
Pushbuttons  
Illuminated PB  
Programmable  
Keylocks  
Rotaries  
Slides  
Tactiles  
Tilt  
Touch  
Indicators  
Accessories  
Supplement

Компания «Океан Электроники» предлагает заключение долгосрочных отношений при поставках импортных электронных компонентов на взаимовыгодных условиях!

Наши преимущества:

- Поставка оригинальных импортных электронных компонентов напрямую с производств Америки, Европы и Азии, а так же с крупнейших складов мира;
- Широкая линейка поставок активных и пассивных импортных электронных компонентов (более 30 млн. наименований);
- Поставка сложных, дефицитных, либо снятых с производства позиций;
- Оперативные сроки поставки под заказ (от 5 рабочих дней);
- Экспресс доставка в любую точку России;
- Помощь Конструкторского Отдела и консультации квалифицированных инженеров;
- Техническая поддержка проекта, помощь в подборе аналогов, поставка прототипов;
- Поставка электронных компонентов под контролем ВП;
- Система менеджмента качества сертифицирована по Международному стандарту ISO 9001;
- При необходимости вся продукция военного и аэрокосмического назначения проходит испытания и сертификацию в лаборатории (по согласованию с заказчиком);
- Поставка специализированных компонентов военного и аэрокосмического уровня качества (Xilinx, Altera, Analog Devices, Intersil, Interpoint, Microsemi, Actel, Aeroflex, Peregrine, VPT, Syfer, Eurofarad, Texas Instruments, MS Kennedy, Miteq, Cobham, E2V, MA-COM, Hittite, Mini-Circuits, General Dynamics и др.);

Компания «Океан Электроники» является официальным дистрибьютором и эксклюзивным представителем в России одного из крупнейших производителей разъемов военного и аэрокосмического назначения «JONHON», а так же официальным дистрибьютором и эксклюзивным представителем в России производителя высокотехнологичных и надежных решений для передачи СВЧ сигналов «FORSTAR».



## JONHON

«JONHON» (основан в 1970 г.)

Разъемы специального, военного и аэрокосмического назначения:

(Применяются в военной, авиационной, аэрокосмической, морской, железнодорожной, горно- и нефтедобывающей отраслях промышленности)

«FORSTAR» (основан в 1998 г.)

ВЧ соединители, коаксиальные кабели, кабельные сборки и микроволновые компоненты:

(Применяются в телекоммуникациях гражданского и специального назначения, в средствах связи, РЛС, а так же военной, авиационной и аэрокосмической отраслях промышленности).



Телефон: 8 (812) 309-75-97 (многоканальный)

Факс: 8 (812) 320-03-32

Электронная почта: [ocean@oceanchips.ru](mailto:ocean@oceanchips.ru)

Web: <http://oceanchips.ru/>

Адрес: 198099, г. Санкт-Петербург, ул. Калинина, д. 2, корп. 4, лит. А