

AMPHENOL PART NUMBER CONFIGURATION
UE86-3G4420-X0X61

- LIGHT PIPE OPTION**
 0 - NO LIGHT PIPE
 1 - 4 LP PER 2X1, NORMAL ORIENTATION
 2 - 2 INNER LP PER 2X1, NORMAL ORIENTATION
 3 - 2 OUTER LP PER 2X1, NORMAL ORIENTATION
 4 - 4 LP PER 2X1, REVERSING ORIENTATION
 5 - 2 INNER LP PER 2X1, REVERSING ORIENTATION
 6 - 2 OUTER LP PER 2X1, REVERSING ORIENTATION
 7 - 3 LP PER 2X1, 2 OUTER LP, NORMAL ORIENTATION
 8 - 3 LP PER 2X1, 2 OUTER LP, REVERSING ORIENTATION

- PACKAGING**
 1 - TRAY PACKAGING (STACKED)
- PLATING OPTIONS FOR CONNECTOR**
 2 - 30µ" GOLD PLATING ON MATING AREA
 15-100µ" MATTE TIN ON TERMINATION
 3 - 30µ" GOLD PLATING ON MATING AREA
 150-300µ" MATTE TIN ON TERMINATION
 5 - 15µ" GOLD PLATING ON MATING AREA
 15-100µ" MATTE TIN ON TERMINATION
 6 - 15µ" GOLD PLATING ON MATING AREA
 150-300µ" MATTE TIN ON TERMINATION

REVISIONS				
REV.	ECN NO.	DESCRIPTION	DATE	APPROVED
D		UPDATE NOTES	AUG 19/14	J.SI
E		CHANGED PCB THICKNESS	NOV 03/15	J.SI
F		REMOVED DIM. ZONE B1, SHEET 2 OF 5	OCT 31/16	J.SI

DATE CODE
 PART NUMBER
 (LAST DIGIT INDICATING PACKAGING TYPE, NOT PRINTED ON THE PART)

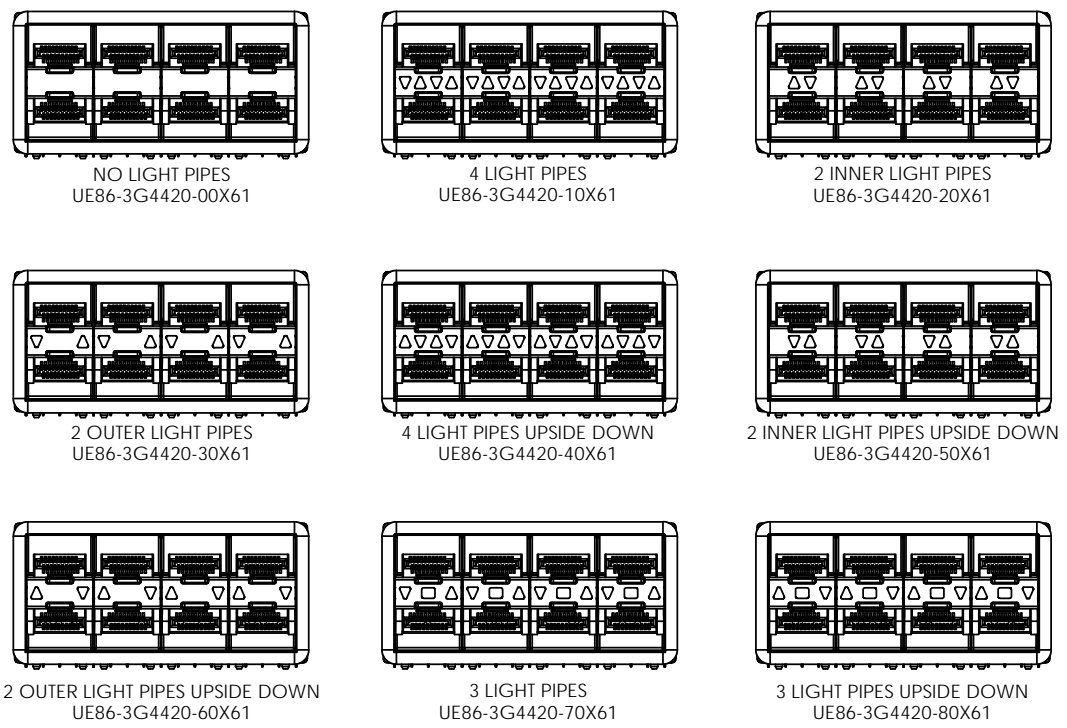
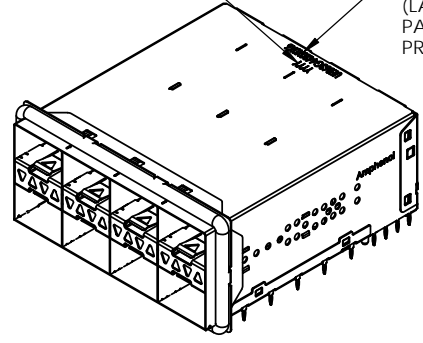

- MATERIAL: (RoHS COMPLIANT)
- CAGE - PRESS FIT: COPPER ALLOY (NICKEL SILVER)
 - CONNECTOR - PRESS FIT:
 - PLASTIC HOUSING: LCP, FLAMMABILITY RATING UL94-V0
 - CONTACTS: PHOSPHOR BRONZE
 - LIGHT PIPE: CLEAR POLYCARBONATE, FLAMMABILITY RATING UL94-V0
 - PACKAGING: TRAY PACKAGING
 - TEMPERATURE RANGE: -40°C TO +85°C
 - EMI GASKET: CONDUCTIVE ELASTOMER UL94-V0



THIS DOCUMENT CONTAINS PROPRIETARY INFORMATION AND SUCH INFORMATION MAY NOT BE DISCLOSED TO OTHERS FOR ANY PURPOSE OR USED FOR MANUFACTURING PURPOSES WITHOUT WRITTEN PERMISSION FROM AMPHENOL CANADA CORP.

UNLESS SPECIFIED OTHERWISE	DRAWN	P. OU	SEP 03/13	Amphenol High Speed Interconnects A Division of Amphenol Corp. www.amphenolcanada.com 2X4 SFP ULTRAPORT WITH LIGHT PIPE OPTIONS AND EMI GASKET	DWG. NO. P-UE86-3G4420-X0X61 REV F
DIMENSIONS ARE IN MILLIMETERS	CHECKED	J. SI	NOV03/15		
REFERENCE IN PARENTHESES	M.E. APP'D				
GENERAL TOLERANCES	Q.A. APP'D				
1 DECIMAL PLACE ±0.25	DWG APP'D	J. SI	NOV03/15	CODE ID NO. 03554 DWG SIZE: A4 SCALE: 2:3 SHEET 1 OF 5	
2 DECIMAL PLACE ±0.15	MATERIAL AND FINISH	SEE NOTES			
3 DECIMAL PLACE N/A	REF.	ECN Exxxxx			
ANGULAR DEGREES ±1°	THIRD ANGLE PROJECTION				
ENG. REL. NO.					

REVISIONS				
REV.	ECN NO.	DESCRIPTION	DATE	APPROVED
D		UPDATE NOTES	AUG 19/14	J.SI
E		CHANGED PCB THICKNESS	NOV 03/15	J.SI
F		REMOVED DIM. ZONE B1, SHEET 2 OF 5	OCT 31/16	J.SI

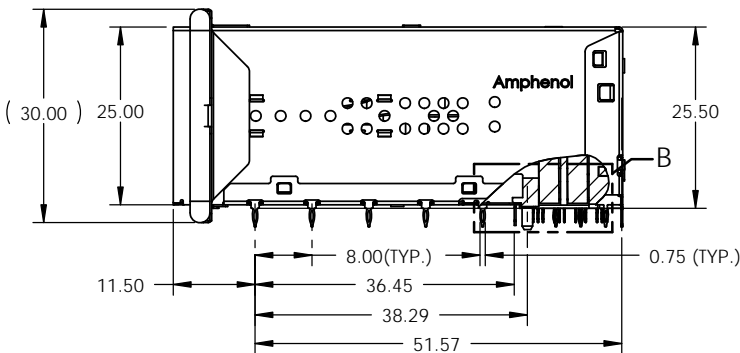
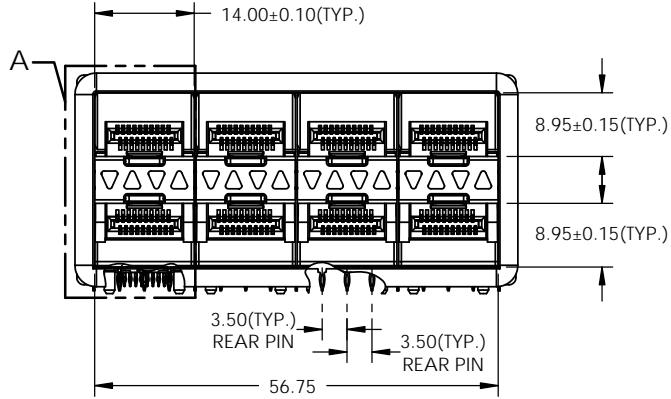
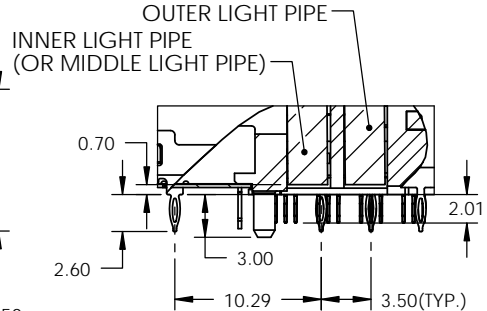
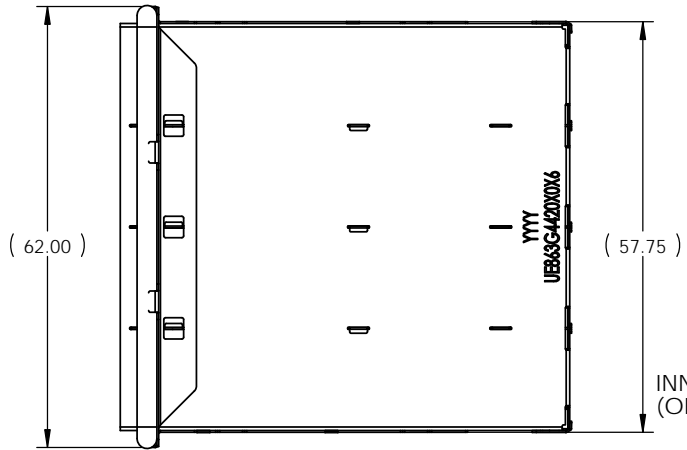
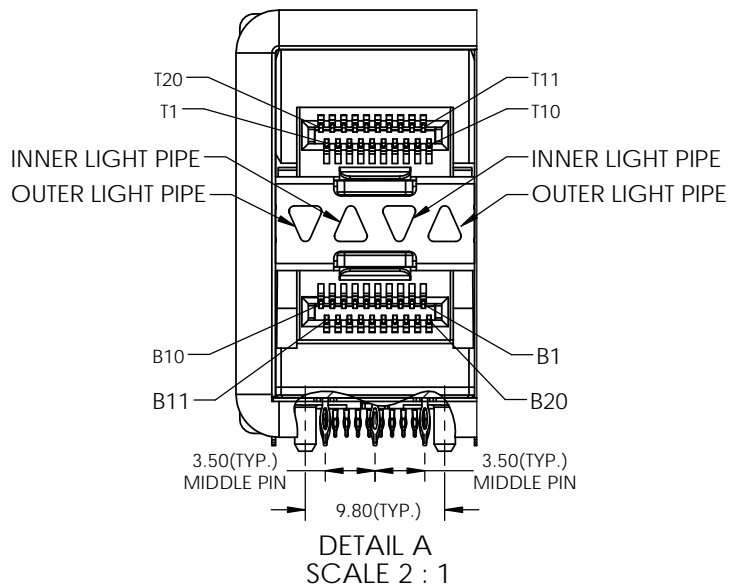

THIS DOCUMENT CONTAINS PROPRIETARY INFORMATION AND SUCH INFORMATION MAY NOT BE DISCLOSED TO OTHERS FOR ANY PURPOSE OR USED FOR MANUFACTURING PURPOSES WITHOUT WRITTEN PERMISSION FROM AMPHENOL CANADA CORP.

UNLESS SPECIFIED OTHERWISE DIMENSIONS ARE IN MILLIMETERS REFERENCE IN PARENTHESES GENERAL TOLERANCES	DRAWN P. OU CHECKED J. SI M.E. APP'D Q.A. APP'D DWG APP'D J. SI MATERIAL AND FINISH REF. ECN Exxxxx	SEP 03/13 NOV03/15	Amphenol High Speed Interconnects A Division of Amphenol Corp. www.amphenolcanada.com
1 DECIMAL PLACE ±0.25 2 DECIMAL PLACE ±0.15 3 DECIMAL PLACE N/A ANGULAR DEGREES ±1° ENG. REL. NO.	SEE NOTES	NOV03/15	
THIRD ANGLE PROJECTION DO NOT SCALE DRAWING			2X4 SFP ULTRAPORT WITH LIGHT PIPE OPTIONS AND EMI GASKET DWG. NO. P-UE86-3G4420-X0X61 CODE ID NO. 03554 DWG SIZE: A4 SCALE: 1:1 SHEET 2 OF 5

REVISIONS				
REV.	ECN NO.	DESCRIPTION	DATE	APPROVED
D		UPDATE NOTES	AUG 19/14	J.SI
E		CHANGED PCB THICKNESS	NOV 03/15	J.SI
F		REMOVED DIM. ZONE B1, SHEET 2 OF 5	OCT 31/16	J.SI

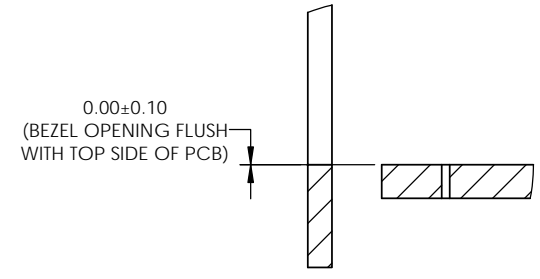
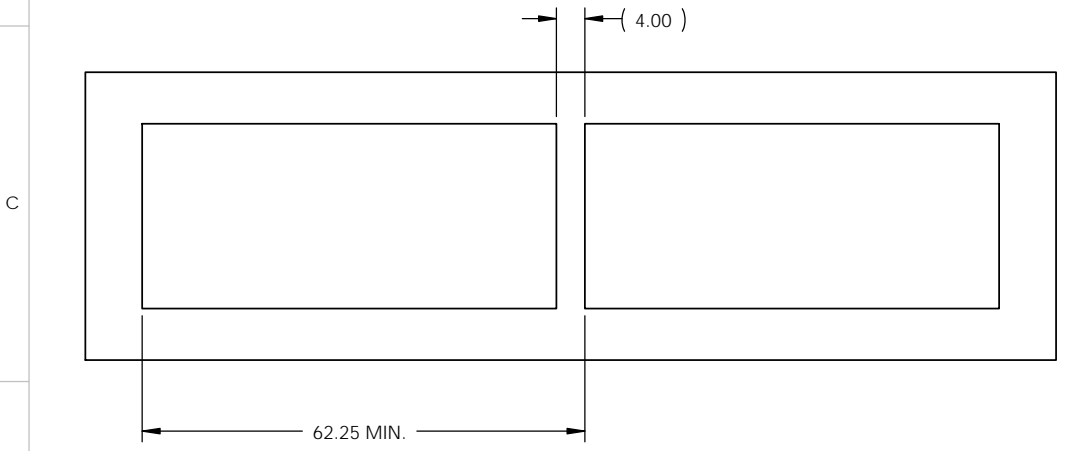
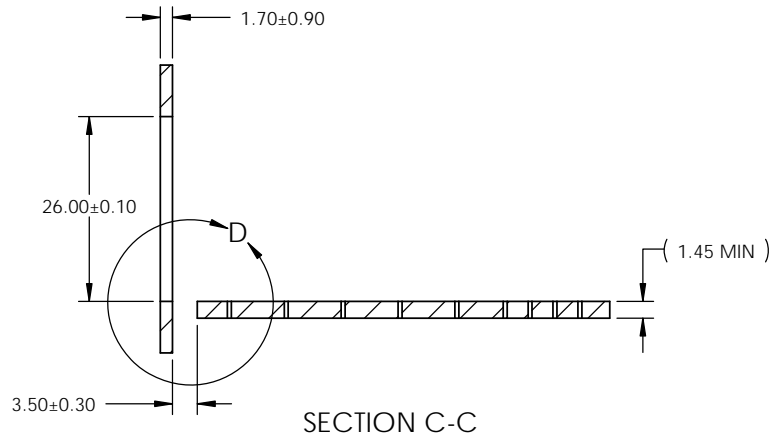
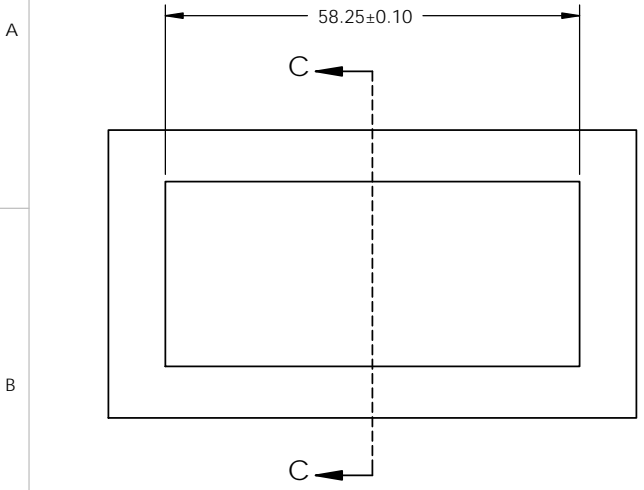

DETAIL D
SCALE 2 : 1

THIS DOCUMENT CONTAINS PROPRIETARY INFORMATION AND SUCH INFORMATION MAY NOT BE DISCLOSED TO OTHERS FOR ANY PURPOSE OR USED FOR MANUFACTURING PURPOSES WITHOUT WRITTEN PERMISSION FROM AMPHENOL CANADA CORP.

UNLESS SPECIFIED OTHERWISE DIMENSIONS ARE IN MILLIMETERS		DRAWN P. OU SEP 03/13	Amphenol High Speed Interconnects A Division of Amphenol Corp. www.amphenolcanada.com
REFERENCE IN PARENTHESES		CHECKED J. SI NOV03/15	
GENERAL TOLERANCES		M.E. APP'D	
1 DECIMAL PLACE ±0.25		Q.A. APP'D	
2 DECIMAL PLACE ±0.15		DWG APP'D J. SI NOV03/15	2X4 SFP ULTRAPORT WITH LIGHT PIPE OPTIONS AND EMI GASKET
3 DECIMAL PLACE N/A		MATERIAL AND FINISH SEE NOTES	
ANGULAR DEGREES ±1°		REF. ECN Exxxxx	DWG. NO. P-UE86-3G4420-X0X61
ENG. REL. NO.		THIRD ANGLE PROJECTION	DO NOT SCALE DRAWING
		CODE ID NO. 03554	DWG SIZE: A4 SCALE: 1:1 SHEET 3 OF 5

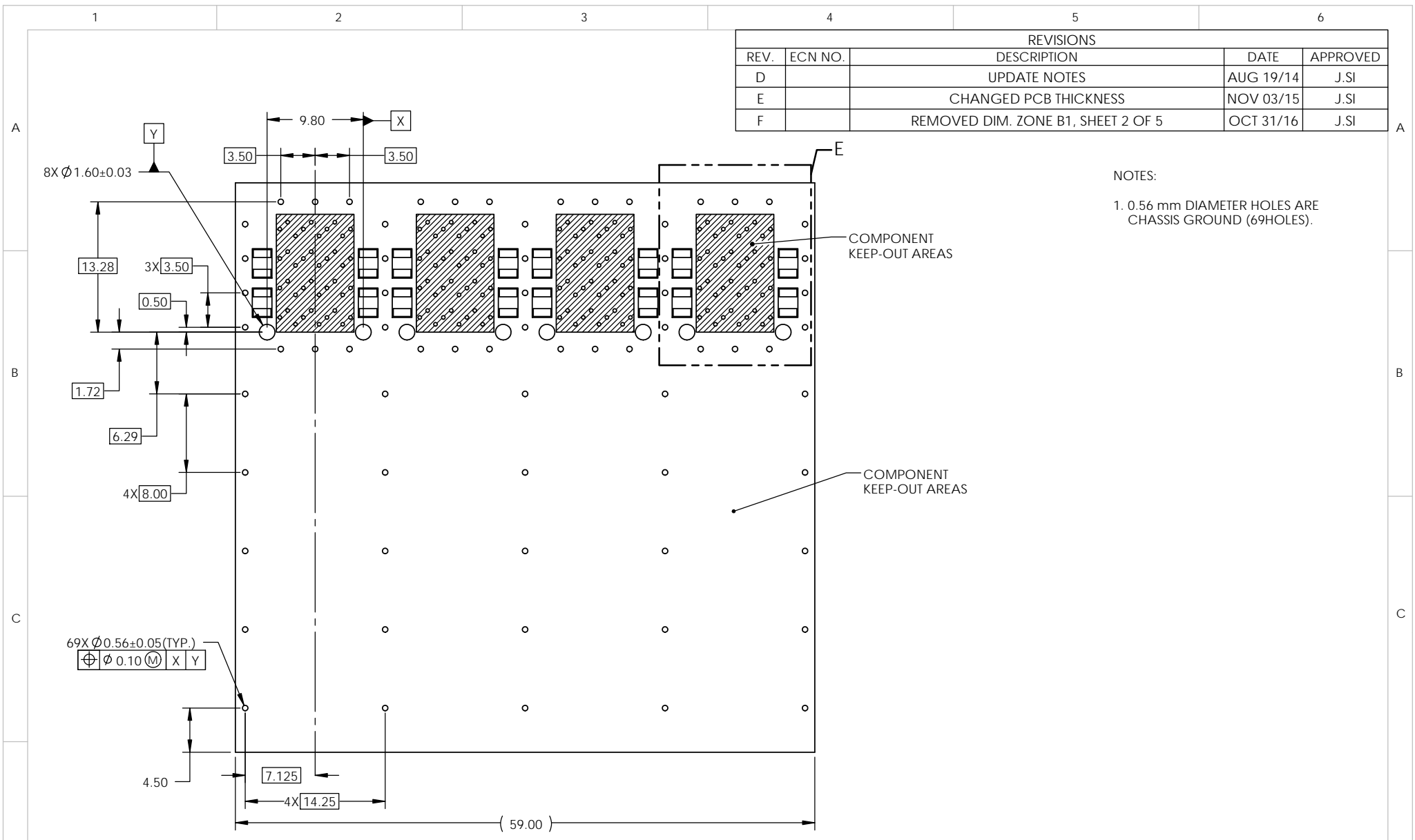

REVISIONS				
REV.	ECN NO.	DESCRIPTION	DATE	APPROVED
D		UPDATE NOTES	AUG 19/14	J.SI
E		CHANGED PCB THICKNESS	NOV 03/15	J.SI
F		REMOVED DIM. ZONE B1, SHEET 2 OF 5	OCT 31/16	J.SI

NOTES:
 1. 0.56 mm DIAMETER HOLES ARE CHASSIS GROUND (69HOLES).

2X4 PCB LAYOUT

THIS DOCUMENT CONTAINS PROPRIETARY INFORMATION AND SUCH INFORMATION MAY NOT BE DISCLOSED TO OTHERS FOR ANY PURPOSE OR USED FOR MANUFACTURING PURPOSES WITHOUT WRITTEN PERMISSION FROM AMPHENOL CANADA CORP.

UNLESS SPECIFIED OTHERWISE DIMENSIONS ARE IN MILLIMETERS		DRAWN P. OU	SEP 03/13	Amphenol High Speed Interconnects A Division of Amphenol Corp. www.amphenolcanada.com 2X4 SFP ULTRAPORT WITH LIGHT PIPE OPTIONS AND EMI GASKET	DWG. NO. P-UE86-3G4420-X0X61 REV F
REFERENCE IN PARENTHESES		CHECKED J. SI	NOV03/15		
GENERAL TOLERANCES		M.E. APP'D			
1 DECIMAL PLACE ±0.25		Q.A. APP'D			
2 DECIMAL PLACE ±0.15		DWG APP'D J. SI	NOV03/15		
3 DECIMAL PLACE N/A		MATERIAL AND FINISH	SEE NOTES		
ANGULAR DEGREES ±1°		REF.	ECN Exxxxx		
ENG. REL. NO.		THIRD ANGLE PROJECTION	DO NOT SCALE DRAWING	CODE ID NO. 03554	DWG SIZE: A4 SCALE: 2:1 SHEET 4 OF 5

REVISIONS				
REV.	ECN NO.	DESCRIPTION	DATE	APPROVED
D		UPDATE NOTES	AUG 19/14	J.SI
E		CHANGED PCB THICKNESS	NOV 03/15	J.SI
F		REMOVED DIM. ZONE B1, SHEET 2 OF 5	OCT 31/16	J.SI

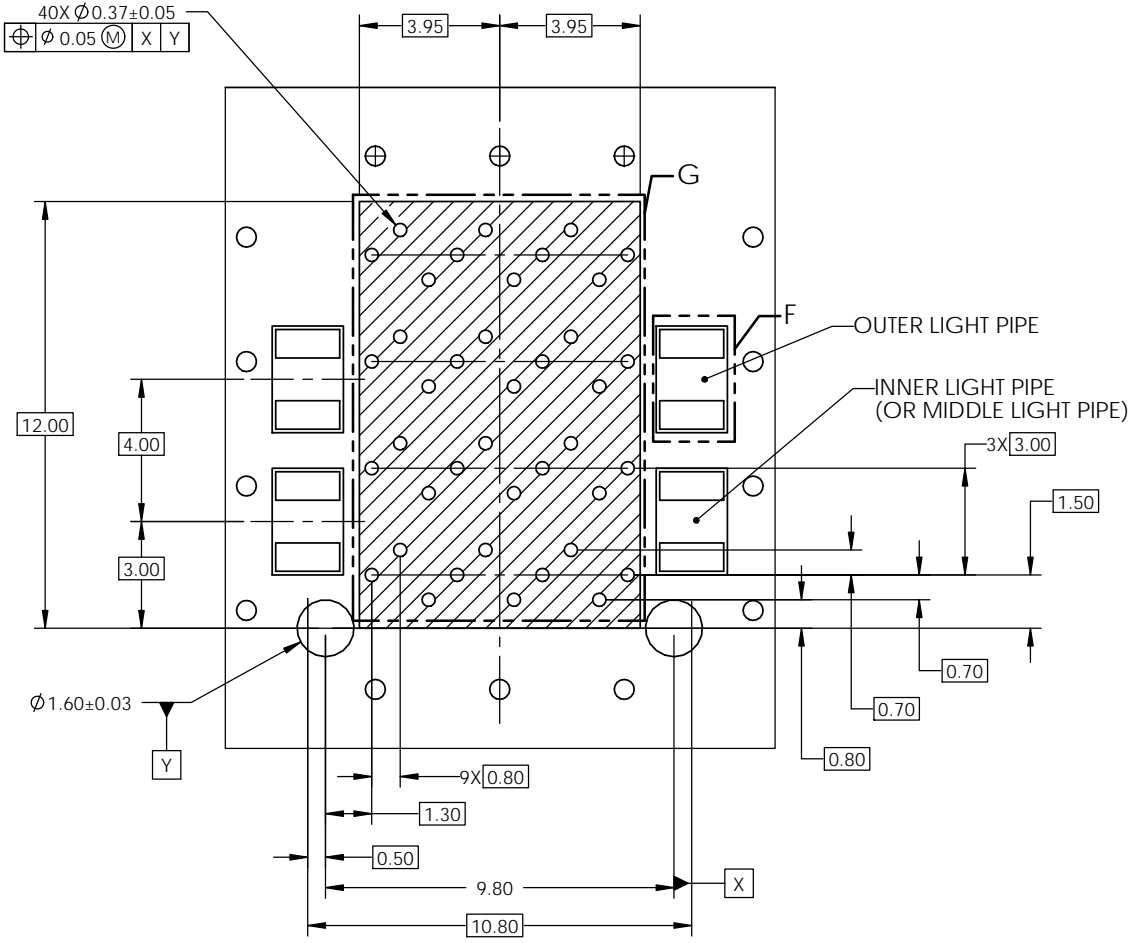

DETAIL E
SCALE 5 : 1

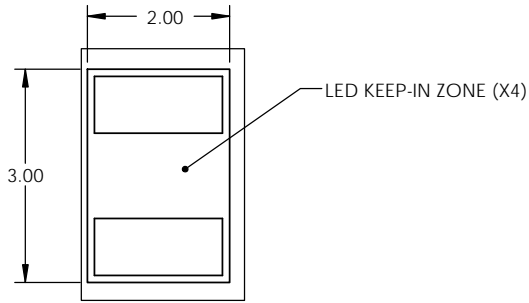

DETAIL F
SCALE 10 : 1

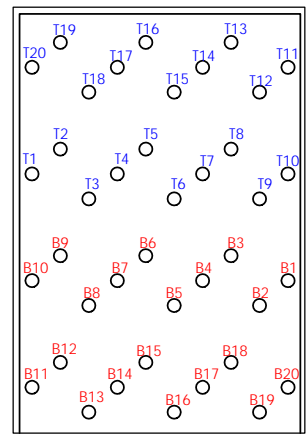

DETAIL G
SCALE 5 : 1

THIS DOCUMENT CONTAINS PROPRIETARY INFORMATION AND SUCH INFORMATION MAY NOT BE DISCLOSED TO OTHERS FOR ANY PURPOSE OR USED FOR MANUFACTURING PURPOSES WITHOUT WRITTEN PERMISSION FROM AMPHENOL CANADA CORP.

UNLESS SPECIFIED OTHERWISE		DRAWN	P. OU	SEP 03/13
DIMENSIONS ARE IN MILLIMETERS		CHECKED	J. SI	NOV03/15
REFERENCE IN PARENTHESES		M.E. APP'D		
GENERAL TOLERANCES		Q.A. APP'D		
1 DECIMAL PLACE	±0.25	DWG APP'D	J. SI	NOV03/15
2 DECIMAL PLACE	±0.15	MATERIAL AND FINISH	SEE NOTES	
3 DECIMAL PLACE	N/A	REF.	ECN Exxxxx	
ANGULAR DEGREES	±1°	THIRD ANGLE PROJECTION	DO NOT SCALE DRAWING	
ENG. REL. NO.				

Amphenol High Speed Interconnects A Division of Amphenol Corp. www.amphenolcanada.com				
2X4 SFP ULTRAPORT WITH LIGHT PIPE OPTIONS AND EMI GASKET				
DWG. NO.		P-UE86-3G4420-X0X61		REV F
CODE ID NO.	03554	DWG SIZE:	A4	SCALE: 2:1
				SHEET 5 OF 5

Компания «Океан Электроники» предлагает заключение долгосрочных отношений при поставках импортных электронных компонентов на взаимовыгодных условиях!

Наши преимущества:

- Поставка оригинальных импортных электронных компонентов напрямую с производств Америки, Европы и Азии, а так же с крупнейших складов мира;
- Широкая линейка поставок активных и пассивных импортных электронных компонентов (более 30 млн. наименований);
- Поставка сложных, дефицитных, либо снятых с производства позиций;
- Оперативные сроки поставки под заказ (от 5 рабочих дней);
- Экспресс доставка в любую точку России;
- Помощь Конструкторского Отдела и консультации квалифицированных инженеров;
- Техническая поддержка проекта, помощь в подборе аналогов, поставка прототипов;
- Поставка электронных компонентов под контролем ВП;
- Система менеджмента качества сертифицирована по Международному стандарту ISO 9001;
- При необходимости вся продукция военного и аэрокосмического назначения проходит испытания и сертификацию в лаборатории (по согласованию с заказчиком);
- Поставка специализированных компонентов военного и аэрокосмического уровня качества (Xilinx, Altera, Analog Devices, Intersil, Interpoint, Microsemi, Actel, Aeroflex, Peregrine, VPT, Syfer, Eurofarad, Texas Instruments, MS Kennedy, Miteq, Cobham, E2V, MA-COM, Hittite, Mini-Circuits, General Dynamics и др.);

Компания «Океан Электроники» является официальным дистрибьютором и эксклюзивным представителем в России одного из крупнейших производителей разъемов военного и аэрокосмического назначения «**JONHON**», а так же официальным дистрибьютором и эксклюзивным представителем в России производителя высокотехнологичных и надежных решений для передачи СВЧ сигналов «**FORSTAR**».



JONHON

«**JONHON**» (основан в 1970 г.)

Разъемы специального, военного и аэрокосмического назначения:

(Применяются в военной, авиационной, аэрокосмической, морской, железнодорожной, горно- и нефтедобывающей отраслях промышленности)

«**FORSTAR**» (основан в 1998 г.)

ВЧ соединители, коаксиальные кабели, кабельные сборки и микроволновые компоненты:

(Применяются в телекоммуникациях гражданского и специального назначения, в средствах связи, РЛС, а так же военной, авиационной и аэрокосмической отраслях промышленности).



Телефон: 8 (812) 309-75-97 (многоканальный)

Факс: 8 (812) 320-03-32

Электронная почта: ocean@oceanchips.ru

Web: <http://oceanchips.ru/>

Адрес: 198099, г. Санкт-Петербург, ул. Калинина, д. 2, корп. 4, лит. А