



# ER6230QI 3A Buck Regulator

Step-Down DC-DC Switching Converter with Integrated MOSFET

## EVALUATION BOARD OVERVIEW

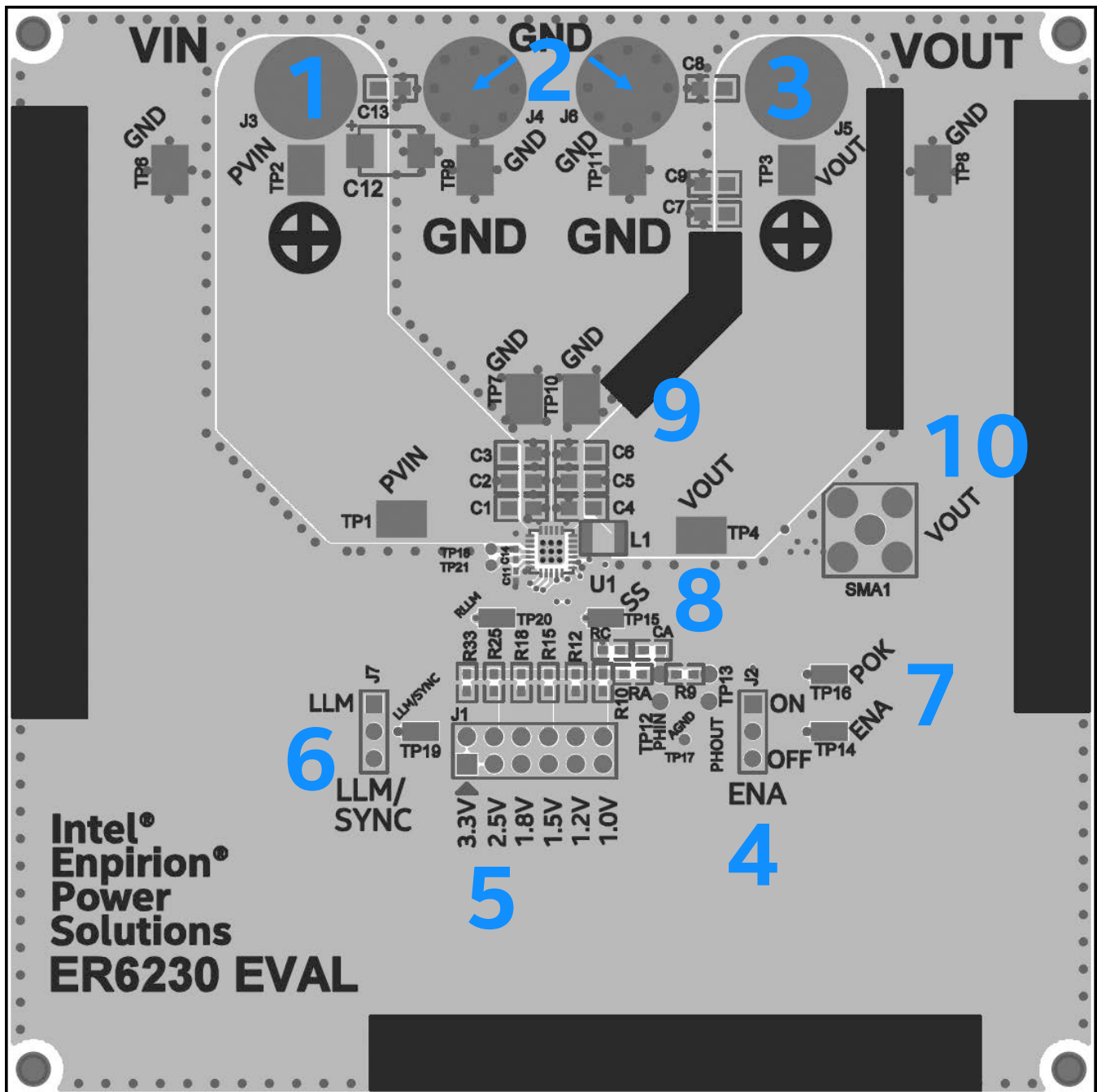

Figure 1: Evaluation Board (EVB) Features (Top View)

**NOTE A:** The ER6230QI Evaluation Board is shown in Figure 1 with the important features numbered.

**NOTE B:** The following instructions will directly correlate with the numbers shown in Figure 1.

## EVALUATION BOARD INSTRUCTIONS

**1) Input Supply (VIN)** - Connect 2.7V to 6.6V supply on VIN (J3). Pay attention to input polarity and do not turn on until everything is connected correctly.

**2) Ground (GND)** - Connect the input and output ground to GND (J4, J6).

**3) Output Voltage (VOUT)** - Connect the load to VOUT (J5). If the instructions were followed up to this point, the device may be powered on.

**4) Enable (ENA)** - The ENABLE is used to enable or disable the device. Connecting a jumper on ENA (J2) towards the OFF side will disable the device. Similarly, connecting a jumper on the ENA (J2) towards the ON side will enable the device. An external signal may be applied to the ENA (TP14) to enable or disable the device (ON > 1.5V, OFF < 1.2V).

**5) Output Voltage Settings (J1)** - The output voltage may be adjusted quickly by placing a jumper one of the selections on J1. The voltages are pre-set by the resistors R33, R25, R18, R15, R12, R10 which corresponds to 3.3V, 2.5V, 1.8V, 1.5V, 1.2V and 1.0V respectively. The compensation CA may be adjusted according to Table 1 for best results. The output voltage may also be adjusted to any voltage as indicated by the equation for RB shown in Figure 2.

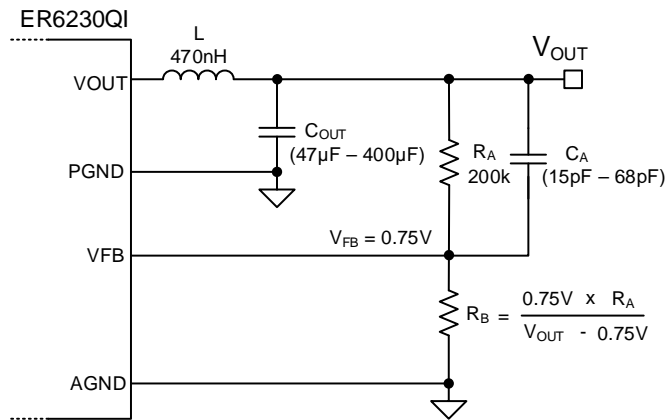

**Figure 2: VOUT Resistor Divider & Compensation Capacitor**

**6) Clock Sync and LLM (LLM/SYNC)** - At static Logic HIGH, device will allow automatic engagement of light load mode. At static logic LOW, the device is forced into

PWM only. A clocked input to this pin will synchronize the internal switching frequency to the external signal. Do not leave this pin floating.

**7) Power OK (POK)** - This is the open drain Power OK flag. When VOUT is over 90% of regulation, POK will be pulled high to VIN through the RPOK resistor (RPOK is on the backside of the board).

**Table 1: External Compensation Recommendations**

VIN	VOUT	RB	CA	RA	COUT (0805)
2.5V – 6.6V	0.75V	OPEN	33pF	200kΩ	2 x 47μF
	0.9V	1MΩ	33pF		
	1.0V	600kΩ	27pF		
	1.2V	332kΩ	27pF		
	1.5V	200kΩ	22pF		
	1.8V	143kΩ	22pF		
	2.5V	84.5kΩ	18pF		
	3.3V	59kΩ	15pF		

**8) Soft Start Capacitor (CSS)** - The soft start capacitor (CSS) is 15nF by default and can be between 10nF to 100nF. The output rise time is controlled by CSS. The voltage rise time calculation is shown:

$$\text{Rise Time} \rightarrow t_{\text{RISE}} [\text{ms}] = C_{\text{SS}} [\text{nF}] \times 0.08$$

$$C_{\text{SS}} = 15\text{nF} \rightarrow t_{\text{RISE}} \approx 1.2\text{ms}$$

$$C_{\text{SS}} = 100\text{nF} \rightarrow t_{\text{RISE}} \approx 8\text{ms}$$

The CSS capacitor is on the backside of the board.

**9) Bulk Capacitors** - The ER6230QI may support up to 400μF on the output, but the compensation should be adjusted accordingly. Using Table 1 as the reference for CA, if COUT is increased, then the CA should also be increased. The relationship is linearly shown below:

$$\Delta C_{\text{OUT}} \approx +100\mu\text{F} \rightarrow \Delta C_{\text{A}} \approx +10\text{pF}$$

The recommended maximum output capacitance (COUT\_MAX) is 400μF and phase-lead capacitance (CA\_MAX) is 68pF.

**10) Output Ripple Measurement (SMA1)** - A SMA cable may be connected to SMA1 to measure the AC coupled output ripple.

## EVALUATION BOARD SCHEMATIC

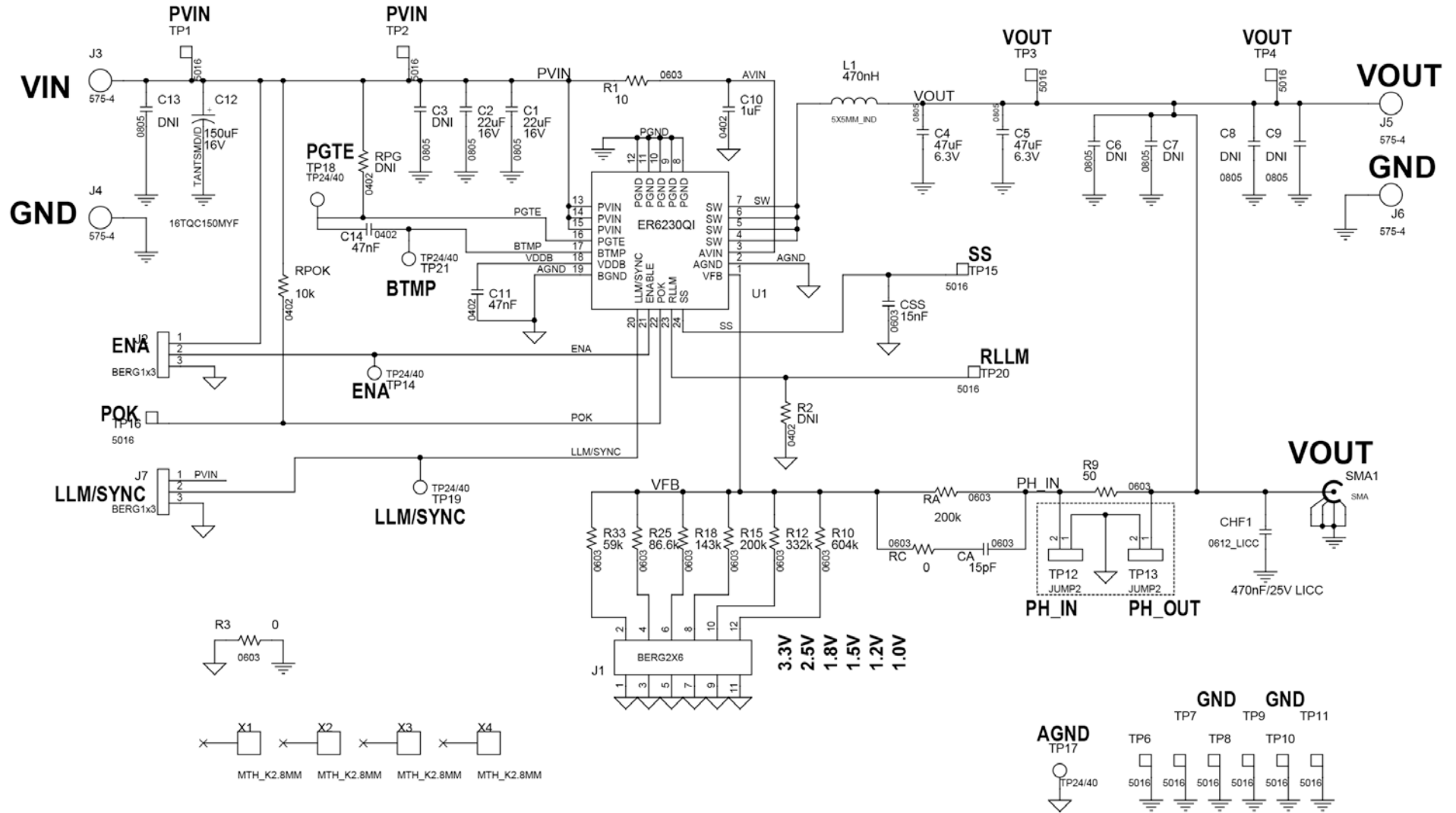

## BILL OF MATERIALS (B.O.M.)

Quantity	Reference	Value	Manufacturer	Part Number	PCB Footprint	Voltage	Tolerance	Power	Dielectric
1	CA	15pF	Murata	GRM1885C1H150JA01D	0603	50V	5%		COG
1	CHF1	470nF	Murata	LLL31MR71E474MA01L	0612				X7R
1	CSS	15nF	Murata	GRM155R71E153KA61D	0402	50V	±10%		X7R
2	C1,C2	22uF	TDK Electronics	C2012X5R1C226M125AC	0805	16V	20%		X5R
2	C4,C5	47uF	Taiyo Yuden	JMK212BJ476MG-T	0805	6.3V	±20%		X5R
1	C10	1uF	TDK Electronics	CGB2A1X5R1E105K033BC	0402	25V	±10%		X5R
2	C11,C14	47nF	Murata	GRM155R71A473KA01	0402	10V	±10%		X7R
1	C12	150uF	Panasonic	16TQC150MYF	TANTSMD/D	16V	20%		
1	L1	470nH	FDK	MIPSAZ3225D	MIPSAZ3225D		30%		
2	R15,RA	200k	Stackpole Electronics Inc	RMCF0603FT200K	0603		±1%	1/8W	
2	R3,RC	0	Panasonic	ERJ-3GEY0R00V	0603			1/10W	
1	RPOK	10k	Yageo	ERJ-2RKF1002X	0402		± 1%	1/16W	
1	R1	10	Panasonic	ERJ-2RKF10R0X	0402		±1%	1/16W	
1	R9	50	Vishay	FC0603E50R0BTBST1	0603		±1%	1/8W	
1	R10	604k	Yageo	RC0603FR-07604KL	0603		±1%	1/8W	
1	R12	332k	Yageo	RC0603FR-07332KL	0603		±1%	1/8W	
1	R18	143k	Yageo	RC0603FR-07143KL	0603		±1%	1/8W	
1	R25	86.6k	Vishay Dale	CRCW060386K6FKEA	0603		±1%	1/8W	
1	R33	59k	Yageo	RC0603FR-0759KL	0603		±1%	1/8W	
1	U1	ER6230QI	Intel	ER6230QI	QFN24_4x4				

## WHERE TO GET MORE INFORMATION

For more information about Intel and Intel Enpirion PowerSoCs, visit:

<https://www.altera.com/products/power/overview.html>

© 2018 Intel Corporation. All rights reserved. Intel, the Intel logo, Altera, ARRIA, CYCLONE, ENPIRION, MAX, MEGACORE, NIOS, QUARTUS, and STRATIX words and logos are trademarks of Intel Corporation or its subsidiaries in the U.S. and/or other countries. Other marks and brands may be claimed as the property of others. Intel reserves the right to make changes to any products and services at any time without notice. Intel assumes no responsibility or liability arising out of the application or use of any information, product, or service described herein except as expressly agreed to in writing by Intel. Intel customers are advised to obtain the latest version of device specifications before relying on any published information and before placing orders for products or services.

\* Other marks and brands may be claimed as the property of others.

Компания «Океан Электроники» предлагает заключение долгосрочных отношений при поставках импортных электронных компонентов на взаимовыгодных условиях!

Наши преимущества:

- Поставка оригинальных импортных электронных компонентов напрямую с производств Америки, Европы и Азии, а так же с крупнейших складов мира;
- Широкая линейка поставок активных и пассивных импортных электронных компонентов (более 30 млн. наименований);
- Поставка сложных, дефицитных, либо снятых с производства позиций;
- Оперативные сроки поставки под заказ (от 5 рабочих дней);
- Экспресс доставка в любую точку России;
- Помощь Конструкторского Отдела и консультации квалифицированных инженеров;
- Техническая поддержка проекта, помощь в подборе аналогов, поставка прототипов;
- Поставка электронных компонентов под контролем ВП;
- Система менеджмента качества сертифицирована по Международному стандарту ISO 9001;
- При необходимости вся продукция военного и аэрокосмического назначения проходит испытания и сертификацию в лаборатории (по согласованию с заказчиком);
- Поставка специализированных компонентов военного и аэрокосмического уровня качества (Xilinx, Altera, Analog Devices, Intersil, Interpoint, Microsemi, Actel, Aeroflex, Peregrine, VPT, Syfer, Eurofarad, Texas Instruments, MS Kennedy, Miteq, Cobham, E2V, MA-COM, Hittite, Mini-Circuits, General Dynamics и др.);

Компания «Океан Электроники» является официальным дистрибьютором и эксклюзивным представителем в России одного из крупнейших производителей разъемов военного и аэрокосмического назначения «JONHON», а так же официальным дистрибьютором и эксклюзивным представителем в России производителя высокотехнологичных и надежных решений для передачи СВЧ сигналов «FORSTAR».



## JONHON

«JONHON» (основан в 1970 г.)

Разъемы специального, военного и аэрокосмического назначения:

(Применяются в военной, авиационной, аэрокосмической, морской, железнодорожной, горно- и нефтедобывающей отраслях промышленности)

«FORSTAR» (основан в 1998 г.)

ВЧ соединители, коаксиальные кабели, кабельные сборки и микроволновые компоненты:

(Применяются в телекоммуникациях гражданского и специального назначения, в средствах связи, РЛС, а так же военной, авиационной и аэрокосмической отраслях промышленности).



Телефон: 8 (812) 309-75-97 (многоканальный)

Факс: 8 (812) 320-03-32

Электронная почта: [ocean@oceanchips.ru](mailto:ocean@oceanchips.ru)

Web: <http://oceanchips.ru/>

Адрес: 198099, г. Санкт-Петербург, ул. Калинина, д. 2, корп. 4, лит. А