

**Enhanced Low Power, BR/EDR/BLE
Bluetooth 5.0 SOC**

The CYW20719 is a BT 5.0 compliant, stand-alone baseband processor with an integrated 2.4 GHz transceiver with BLE, EDR and BR. The device is intended for use in audio, IoT, sensors (medical, home, security, and so forth) and human interface device (HID) applications. Manufactured using an advanced 40nm CMOS low-power fabrication process, the CYW20719 employs high level of integration to reduce external components, thereby minimizing application footprint and costs.

This datasheet provides details of the functional, operational, and electrical characteristics of the CYW20719 device. It is intended for hardware, design, application, and OEM engineers.

Figure 1. Functional Block Diagram

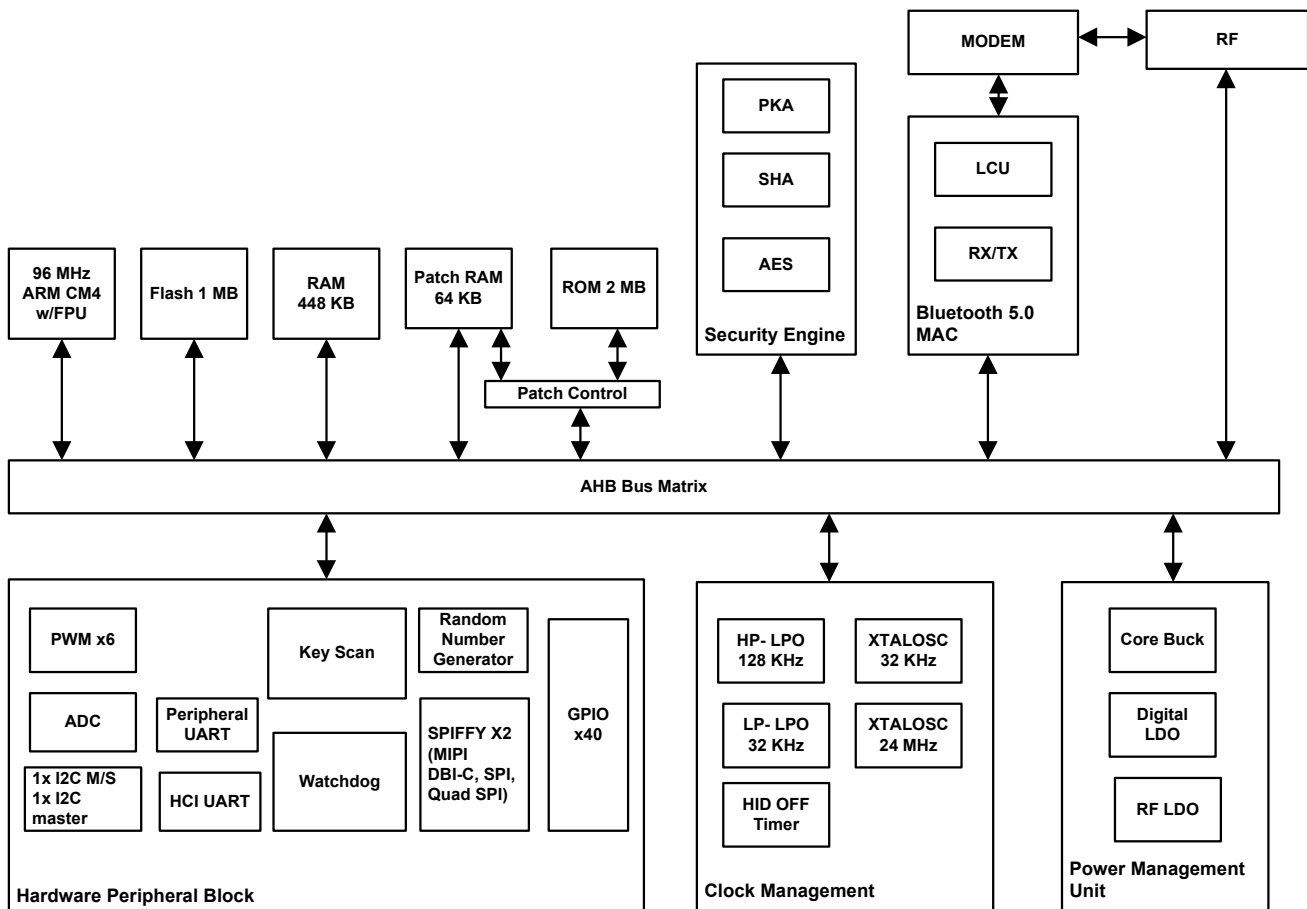

Features

Bluetooth Subsystem

- Complies with Bluetooth Core Specification v5.0 with LE 2 Mbps
- Supports Basic Rate (BR), Enhanced Data Rate (EDR) 2&3 Mbps, Bluetooth Low Energy (BLE)
- Supports Adaptive Frequency Hopping (AFH)
- TX power 4 dBm
- RX sensitivity -95.5 dBm (BLE)
- Ultra-low-power radio
 - RX current 5.9 mA (BLE)
 - TX current 5.6 mA @ 0 dBm (BLE)

Coexistence Support

- Support for Global Coexistence Interface for easy coexistence implementation with select Cypress Wi-Fi devices

MCU Subsystem

- 96-MHz Arm Cortex-M4 microcontroller unit (MCU) with floating point unit (FPU)
- Supports serial wire debug (SWD)
- Runs Bluetooth stack and application
- Option to execute from on-chip flash or RAM

Memory Subsystem

- 1 MB flash
- 512 KB RAM
- 2 MB ROM that stores Bluetooth stack and driver and offloads flash for user applications

Audio features and interfaces

- 1x I²S with master and slave modes
- 1x PCM
- PDM²
- Analog front end for analog microphone¹

Clocks

- On-chip 32 kHz oscillator (LP-LPO)
- On-chip 128 kHz oscillator (HP-LPO)
- 32 kHz crystal oscillator (Optional if low power modes not required)
- 24 MHz crystal oscillator
- 48-bit real time clock (RTC)

Peripherals and communication

- 6x 16-bit PWMs
- Programmable key-scan matrix interface, up to 8x20 key-scanning matrix ^{1,2}
- Quadrature decoder²
- Watchdog timer (WDT)
- 1x peripheral UART, 1x UART for programming and HCI
- 2x SPI (master/slave mode) Blocks (SPI, Quad SPI, and MIPI DBI-C)
- 1x I2C master/slave and 1x I2C master
- 1x 28-channel ADC (10-ENOB for DC measurement and 12-ENOB for Audio measurement)
- Hardware security engine²

General Purpose Input Output (GPIO)

- 16 GPIOs on QFN package
- 40 GPIOs on WLCSP package
- Support up to 3.63 V operation
- Four GPIOs support 16 mA and 8 mA sink at 3.3 V and 1.8 V respectively

Operating voltage and low-power support

- Wide operating voltage range: 1.90 V to 3.63 V
- 5 power modes to implement ultra-low power application – managed by real time operating system
- 0.4 uA current in HID-OFF mode (wake from GPIO).

Packages

- 5 mm x 5 mm 40-pin quad flat no-lead (QFN)
- 3.2 mm x 3.1 mm 134-ball Wafer Level Chip Scale Package (WLCSP)

Software Support

- WICED Studio

Applications

- Wearables and Fitness bands
- Headsets, earbuds, and other audio solutions
- Home automation
- Blood pressure monitors and other medical applications
- Proximity sensors
- Key Fobs
- Thermostats and thermometers
- Toys

1. Available only in WLCSP Package

2. Subjected to driver support in WICED[®] Studio

Contents

| | | | |
|---|----------|--|-----------|
| 1. Bluetooth Baseband Core | 4 | 6.13 PCM Interface | 14 |
| 1.1 BQB and Regulatory Testing Support | 4 | 6.14 Security Engine | 14 |
| 2. MCU | 5 | 6.15 Power Modes | 15 |
| 3. External Reset | 5 | 7. Firmware | 15 |
| 4. Power Management Unit (PMU) | 6 | 8. Pin Assignments and GPIOs | 16 |
| 5. Integrated Radio Transceiver | 7 | 8.1 40-Pin QFN and WLCSP Pin Assignments | 16 |
| 5.1 Transmitter Path | 7 | 8.2 40-Pin QFN and WLCSP GPIOs | 18 |
| 5.2 Receiver Path | 7 | 9. Pin/Ball Maps | 23 |
| 5.3 Local Oscillator (LO) | 7 | 9.1 40-Pin QFN Pin Map | 23 |
| 6. Peripheral and Communication Interfaces | 8 | 9.2 WLCSP Ball Map | 24 |
| 6.1 I2C Compatible Master | 8 | 10. Specifications | 29 |
| 6.2 HCI UART Interface | 8 | 10.1 Electrical Characteristics | 29 |
| 6.3 Peripheral UART Interface | 8 | 10.2 RF Specifications | 33 |
| 6.4 Crystal Oscillators | 9 | 10.3 Timing and AC Characteristics | 36 |
| 6.5 GPIO Ports | 10 | 11. Mechanical Information | 42 |
| 6.6 Keyboard Scanner (Available only on WLCSP Package) | 11 | 11.1 40-Pin QFN Package | 42 |
| 6.7 Mouse Quadrature Signal Decoder | 11 | 11.2 WLCSP Package | 43 |
| 6.8 ADC | 11 | 11.3 WLCSP Package Keep-out | 44 |
| 6.9 PWM | 12 | 11.4 Tape Reel and Packaging Specifications | 44 |
| 6.10 Serial Peripheral Interface block | 13 | 12. Ordering Information | 45 |
| 6.11 Pulse Density Modulation (PDM) Microphone ... | 13 | 13. Additional Information | 45 |
| 6.12 I2S Interface | 13 | 13.1 Acronyms and Abbreviations | 45 |
| | | Sales, Solutions, and Legal Information | 49 |

1. Bluetooth Baseband Core

The Bluetooth Baseband Core (BBC) implements all time-critical functions required for high-performance Bluetooth operation. The BBC manages the buffering, segmentation, and routing of data for all connections. It prioritizes and schedules all RX/TX activities including adv, paging, scanning, and servicing of connections. In addition to these functions, it independently handles the host controller interface (HCI) including all commands, events, and data flowing over HCI. The core also handles symbol timing, forward error correction (FEC), header error control (HEC), cyclic redundancy check (CRC), authentication, data encryption/decryption, and data whitening/dewhitening.

Table 1. Bluetooth Features

| Bluetooth 1.0 | Bluetooth 1.2 | Bluetooth 2.0 |
|----------------------------|------------------------------|-----------------------------|
| Basic Rate | Interlaced Scans | EDR 2 Mbps and 3 Mbp |
| SCO | Adaptive Frequency Hopping | – |
| Paging and Inquiry | eSCO | – |
| Page and Inquiry Scan | – | – |
| Sniff | – | – |
| Bluetooth 2.1 | Bluetooth 3.0 | Bluetooth 4.0 |
| Secure Simple Pairing | Unicast Connectionless Data | Bluetooth Low Energy |
| Enhanced Inquiry Response | Enhanced Power Control | – |
| Sniff Subrating | eSCO | – |
| Bluetooth 4.1 | Bluetooth 4.2 | Bluetooth 5.0 |
| Low Duty Cycle Advertising | Data Packet Length Extension | LE 2 Mbps |
| Dual Mode | LE Secure Connection | Slot Availability Mask |
| LE Link Layer Topology | Link Layer Privacy | High Duty Cycle Advertising |

1.1 BQB and Regulatory Testing Support

The CYW20719 fully supports Bluetooth Test mode as described in Part 1:1 of the Specification of the Bluetooth System v3.0. This includes the transmitter tests, normal and delayed loop back tests, and reduced hopping sequence.

In addition to the standard Bluetooth Test Mode, the CYW20719 also supports enhanced testing features to simplify RF debugging and qualification and type-approval testing. These features include:

- Fixed frequency carrier wave (unmodulated) transmission
 - Simplifies some type-approval measurements (Japan)
 - Aids in transmitter performance analysis
- Fixed frequency constant receiver mode
 - Receiver output directed to I/O pin
 - Allows for direct BER measurements using standard RF test equipment
 - Facilitates spurious emissions testing for receive mode
- Fixed frequency constant transmission
 - 8-bit fixed pattern or PRBS-9
 - Enables modulated signal measurements with standard RF test equipment

2. MCU

The CYW20719 includes a Cortex M4 processor with 2 MB of ROM, 448 KB of data RAM, 64 KB of patch RAM, and 1 MB of on-chip flash. The CM4 has a maximum speed of 96 MHz. CYW20719 supports execution from on-chip flash (OCF).

The CM4 also includes a single precision IEEE 754 compliant floating point unit (FPU).

The CM4 runs all the BT layers as well as application code. The ROM includes LM, HCI, L2CAP, GATT, as well as other stack layers freeing up the flash for application usage. A standard SWD Interface provides debugging support.

3. External Reset

An external active-low reset signal, RESET_N, can be used to put the CYW20719 in the reset state. The RESET_N should be released only after the VDDO supply voltage level has been stabilized for at least 35 ms.

4. Power Management Unit (PMU)

Figure 2 shows the CYW20719 PMU block diagram. The CYW20719 includes an integrated buck regulator, a bypass LDO, a capless LDO for digital circuits and a separate LDO for RF. The bypass LDO automatically takes over from the buck once V_{bat} supply falls below 2.1 V.

The voltage levels shown in this figure are the default settings; the firmware may change voltage levels based on operating conditions.

Figure 2. Default Usage Mode

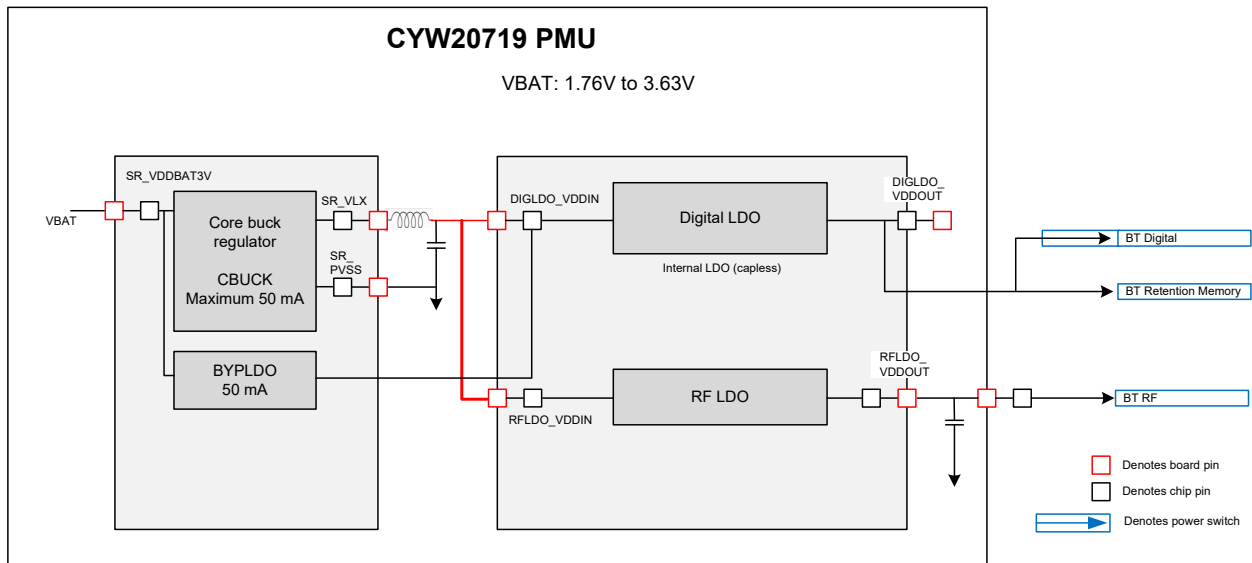

5. Integrated Radio Transceiver

The CYW20719 has an integrated radio transceiver that has been designed to provide low power operation in the globally available 2.4 GHz unlicensed ISM band. It is fully compliant with the Bluetooth Radio Specification and exceeds the requirements to provide the highest communication link quality of service.

5.1 Transmitter Path

The CYW20719 features a fully integrated transmitter. The baseband transmit data is GFSK modulated in the 2.4 GHz ISM band.

Digital Modulator

The digital modulator performs the data modulation and filtering required for the GFSK signal. The fully digital modulator minimizes any frequency drift or anomalies in the modulation characteristics of the transmitted signal.

Power Amplifier

The CYW20719 has an integrated power amplifier (PA) that can transmit up to +4 dBm for class 2 operation.

5.2 Receiver Path

The receiver path uses a low IF scheme to down-convert the received signal for demodulation in the digital demodulator and bit synchronizer. The receiver path provides a high degree of linearity, and an extended dynamic range to ensure reliable operation in the noisy 2.4 GHz ISM band. The front-end topology, which has built-in out-of-band attenuation, enables the CYW20719 to be used in most applications without off-chip filtering.

Digital Demodulator and Bit Synchronizer

The digital demodulator and bit synchronizer take the low-IF received signal and perform an optimal frequency tracking and bit synchronization algorithm.

Receiver Signal Strength Indicator

The radio portion of the CYW20719 provides a receiver signal strength indicator (RSSI) to the baseband. This enables the controller to take part in a Bluetooth power-controlled link by providing a metric of its own receiver signal strength to determine whether the transmitter should increase or decrease its output power.

5.3 Local Oscillator (LO)

LO provides fast frequency hopping (1600 hops/second) across the 79 maximum available channels for BR/EDR functionality. The CYW20719 uses an internal loop filter.

6. Peripheral and Communication Interfaces

6.1 I²C Compatible Master

The CYW20719 provides a 2-pin I²C compatible Master interface to communicate with I²C compatible peripherals. The I²C compatible master supports the following clock speeds:

- 100 kHz
- 400 kHz
- 800 kHz (Not a standard I²C-compatible speed.)
- 1 MHz (Compatibility with high-speed I²C-compatible devices is not guaranteed.)

SCL and SDA lines can be routed to any of the P0-P39 GPIOs allowing for flexible system configuration. When used as SCL/SDA the GPIOs go into open drain mode and require an external pull-up for proper operation. I²C block does not support multi master capability by either master/slave devices.

I²C1 is Master Only; I²C2 is Master/Slave. The Slave support is subject to driver support in WICED[®] Studio.

6.2 HCI UART Interface

The CYW20719 includes a UART interface for factory programming as well as when operating as a BT HCI device in a system with an external host. The UART physical interface is a standard, 4-wire interface (RX, TX, RTS, and CTS) with adjustable baud rates from 115200 bps to 1.5 Mbps. Typical rates are 115200, 921600, 1500000 bps although intermediate speeds are also available. Support for changing the baud rate during normal HCI UART operation is included through a vendor-specific command. The CYW20719 UART operates correctly with the host UART as long as the combined baud rate error of the two devices is within $\pm 5\%$. The UART interface has a 1040-byte receive FIFO and a 1040-byte transmit FIFO to support enhanced data rates. The interface supports the Bluetooth UART HCI (H4) specification. The default baud rate for H4 is 115.2 kbaud.

During HCI mode the DEV_WAKE signal can be programmed to wake up the CYW20719 or allow the CYW20719 to sleep when radio activities permit. The CYW20719 can also wake up the host as needed or allow the host to sleep via the HOST_WAKE signal. The combined two signals allow the host and the CYW20719 to optimize system power consumption by allowing independent control of low power modes. DEV_WAKE and HOST_WAKE signals can be enabled via a vendor specific command.

6.3 Peripheral UART Interface

The CYW20719 has a second UART that may be used to interface to peripherals. This peripheral UART is accessed through the optional I/O ports, which can be configured individually and separately for each functional pin. The CYW20719 can map the peripheral UART to any GPIO (P0-P39). The Peripheral UART is functionally the same as HCI UART but with a 256 byte transmit and receive FIFO.

6.4 Crystal Oscillators

6.4.1 24-MHz Crystal Oscillator

The CYW20719 uses a 24 MHz crystal oscillator (XTAL). The XTAL must have an accuracy of ± 20 ppm as defined by the Bluetooth specification. Two external load capacitors are required to work with the crystal oscillator. The selection of the load capacitors is XTAL-dependent (see Figure 3).

Figure 3. Recommended 24 MHz Oscillator Configuration

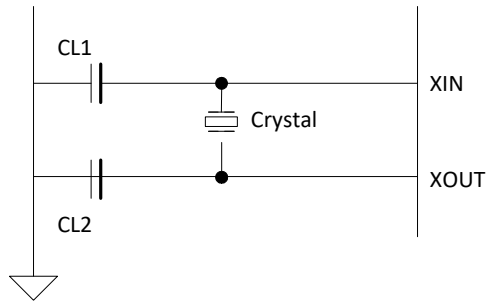

Table 2. Reference Crystal Electrical Specifications

| Parameter | Conditions | Minimum | Typical | Maximum | Unit |
|------------------------------|--|-------------|---------|----------|---------|
| Nominal frequency | – | – | 24.000 | – | MHz |
| Oscillation mode | – | Fundamental | | | – |
| Frequency Accuracy | Includes operating temperature range and aging | – | – | ± 20 | ppm |
| Equivalent series resistance | – | – | – | 60 | ohm |
| Load capacitance | – | – | 8 | – | pF |
| Drive level | – | – | – | 200 | μ W |
| Shunt capacitance | – | – | – | 2 | pF |

6.4.2 32 kHz Crystal Oscillator

The CYW20719 includes a 32 KHz oscillator to provide accurate timing during low power operations. Figure 4 shows the 32 kHz XTAL oscillator with external components and Table 3 lists the oscillator's characteristics. This oscillator can be operated with 32.768 kHz crystal oscillator or be driven with a clock input at similar frequency. The default component values are: R1 = 10 MΩ and C1 = C2 = ~6 pF. The values of C1 and C2 are used to fine-tune the oscillator.

Figure 4. Recommended 32 kHz Oscillator Electrical Specification

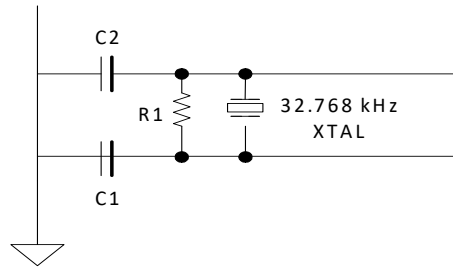

Table 3. Reference 32 kHz Oscillator Electrical Specification

| Parameter | Symbol | Conditions | Minimum | Typical | Maximum | Unit |
|-----------------------------|---------------|--|---------|---------|---------|---------|
| Output frequency | F_{oscout} | – | – | 32.768 | – | kHz |
| Frequency tolerance | – | Crystal-dependent | – | 100 | – | ppm |
| Start-up time | $T_{startup}$ | – | – | 500 | – | ms |
| XTAL drive level | P_{drv} | For crystal selection | – | – | 0.5 | μ W |
| XTAL series resistance | R_{series} | For crystal selection | – | – | 70 | kΩ |
| XTAL shunt capacitance | C_{shunt} | For crystal selection | – | – | 2.2 | pF |
| External AC Input Amplitude | $V_{IN} (AC)$ | $C_{couple} = 100 \text{ pF};$ $R_{bias} = 10 \text{ Mohm}$ | 400 | – | – | mVpp |

6.5 GPIO Ports

The CYW20719 has 40 GPIOs labeled P0-P39 on WLCSP package and 16 GPIOs on QFN package. All GPIOs support the following:

- programmable pull-up/down of approx 45K Ohms.
- input disable, allowing pins to be left floating or analog signals connected without risk of leakage.
- source/sink 8 mA at 3.3 V and 4 mA at 1.8 V.
- P15 is Bonded to the same pin as XTALI_32K on the QFN package (Pin 32). If External 32.768KHz crystal is not used, then this pin can be used as GPIO P15.
- P26/P27/P28/P29 (some of these pins are not available on QFN package) sink/source 16 mA at 3.3 V and 8 mA at 1.8 V.

Most peripheral functions can be assigned to any GPIO. For details, refer to Table 4 and Table 5.

For more details on Supermux configuration and control, refer to "Supermux Wizard for CYW20719" user guide.

6.6 Keyboard Scanner (Available only on WLCSP Package)

The CYW20719 includes a HW keyscanner that supports a maximum matrix size of 20x8. The scanner has 8 inputs (also referred to as rows) and 20 outputs (also referred to as columns). Keys are detected by driving the columns down sequentially and sampling the rows. The HW scanner includes support for ghost key detection and debouncing. The scanner can also operate in sleep and PDS mode allowing low power operation while continuing to detect/store all key strokes, up or down. In other low power modes, the scanner can continue to monitor the matrix and initiate exit to active mode upon detecting a change of state.

Note: Subject to the driver support in WICED[®] Studio.

6.7 Mouse Quadrature Signal Decoder

The CYW20719 includes one double-axis and one single axis quadrature decoders. There are two input lines for each axis and a programmable control signal that can be active high or low. The application can access the quadrature interface via the driver included in the firmware.

Note: Subject to the driver support in WICED[®] Studio.

6.8 ADC

CYW20719 includes is a Σ - Δ ADC designed for audio (13 bits) and DC (10 bits) measurements. The ADC can measure the voltage on 28 GPIO. When used for analog inputs, the GPIOs must be placed in digital input disable mode to disconnect the digital circuit from the pin and avoid leakage. The internal band gap reference has $\pm 5\%$ accuracy without calibration. Calibration and digital correction schemes can be applied to reduce ADC absolute error and improve measurement accuracy in DC mode.

- P0, P1, P8-P18, P21-23, P28-P38 can be used as ADC inputs.

6.9 PWM

The CYW20719 has six internal PWMs, labeled PWM0-5

- Each of the six PWM channels contains the following registers:
 - 16-bit initial value register (read/write)
 - 16-bit toggle register (read/write)
 - 16-bit PWM counter value register (read)
- PWM configuration register is shared among PWM0-5 (read/write). This 6-bit register is used:
 - To enable/disable each PWM channel
 - To select the clock of each PWM channel
 - To invert the output phase of each PWM channel

The application can access the PWM module through the FW driver.

Figure 5 shows the structure of one PWM channel.

Figure 5. PWM Block Diagram

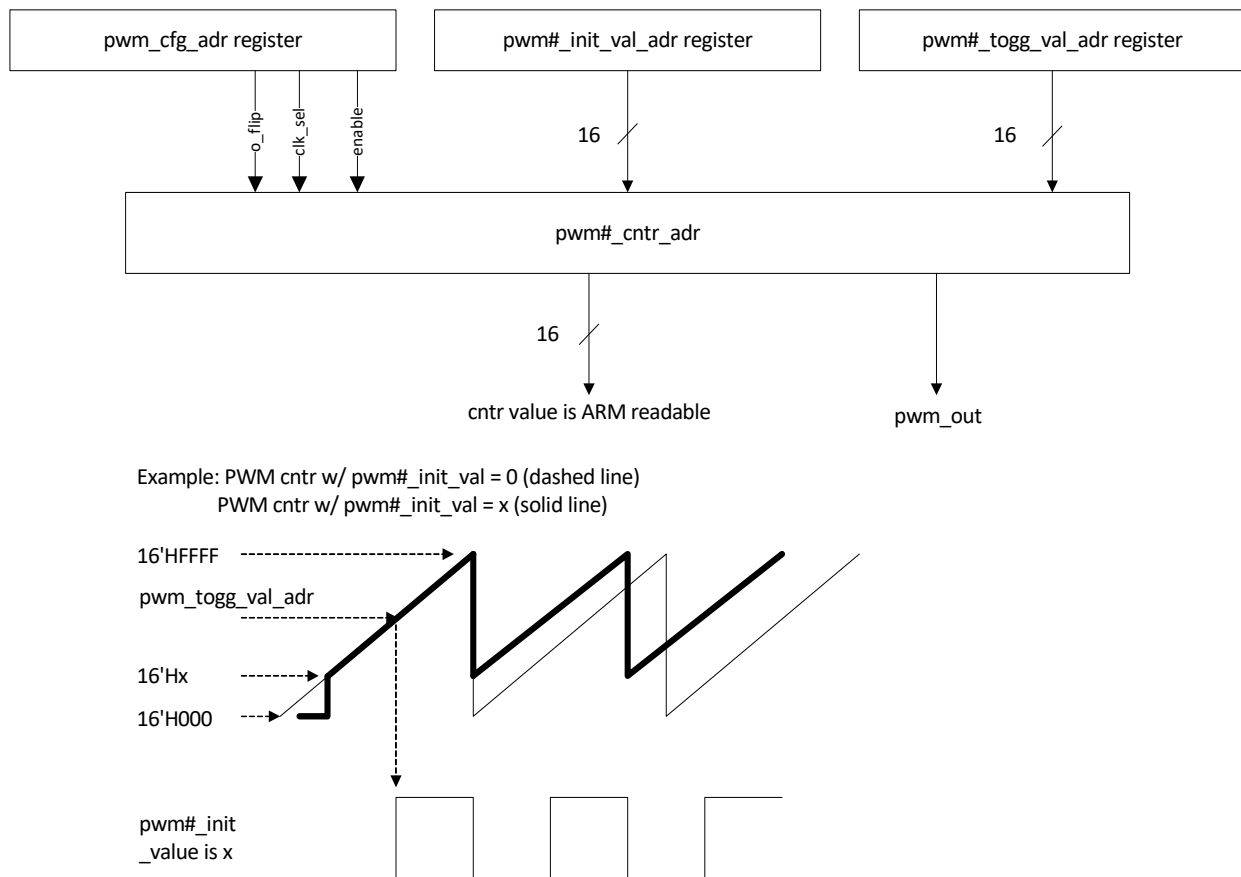

6.10 Serial Peripheral Interface block

The CYW20719 has two independent SPI interfaces. Both interfaces support Single, Dual, and Quad mode SPI operations as well as MIPI DBI-C Interface. Either of the interface can be a master/slave. SPI2 can support only one Slave. SPI1 has a 1024 byte transmit and receive buffers which is shared with the host UART interface. SPI2 has a dedicated 256 byte transmit and receive buffers. To support more flexibility for user applications, the CYW20719 has optional I/O ports that can be configured individually and separately for each functional pin. SPI I/O voltage depends on VDDO.

6.10.1 MIPI interface

There are three options in DBI type-C corresponding to 9-bit, 16-bit, and 8-bit modes. The CYW20719 plays the role of host, and only the 9-bit and 8-bit modes (option 1 and option 3 in DBI-C spec) are supported. In the 9-bit mode, the SCL, CS, MOSI, and MISO pins are used. In the 8-bit mode, an additional pin DCX, indicating whether the current outgoing bit stream is a command or data byte is required.

6.11 Pulse Density Modulation (PDM) Microphone

The CYW20719 accepts a $\Sigma\Delta$ -based one-bit PDM input stream and outputs filtered samples at either 8 kHz or 16 kHz sampling rates. The PDM signal derives from an external kit that can process analog microphone signals and generate digital signals. The PDM input shares the filter path with the aux ADC. Two types of data rates can be supported:

- 8 kHz
- 16 kHz

The external digital microphone takes in a 2.4 MHz clock generated by the CYW20719 and outputs a PDM signal which is registered by the PDM interface with either the rising or falling edge of the 2.4 MHz clock selectable through a programmable control bit. The design can accommodate two simultaneous PDM input channels, so stereo voice is possible.

Note: Subject to the driver support in WICED Studio.

6.12 I²S Interface

The CYW20719 supports a single I²S digital audio port in both master and slave modes. The I²S signals are:

- I²S Clock: I²S SCK
- I²S Word Select: I²S WS
- I²S Data Out: I²S DO
- I²S Data In: I²S DI

I²S SCK and I²S WS become outputs in master mode and inputs in slave mode, while I²S DO always stays as an output and I²S DI stays as input. The channel word length is fixed to 16 bits (frame length of 32 bits) and the data is justified so that the MSB of the left-channel data is aligned with the MSB of the I²S bus, as per I²S Specifications. The MSB of each data word is transmitted one bit clock cycle after the I²S WS transition, synchronous with the falling edge of bit clock. Left Channel data is transmitted when I²S WS is low, and right-channel data is transmitted when I²S WS is high. Data bits sent by the CYW20719 are synchronized with the falling edge of I²S SCK and should be sampled by the receiver on the rising edge of the I²S SCK.

The I²S port is primarily used to transfer audio samples while using the A2DP profile¹. The A2DP controller is half duplex and the direction of the audio samples depend on the A2DP role (sink/source). The I²S clock in the master mode can either be

- 44.1 KHz x 32 bits per frame = 1411.2 KHz
- 48 KHz x 32 bits per frame = 1536 KHz

In the slave mode, any clock rate is supported up to a maximum of 3.072 MHz.

Note: PCM interface shares HW with the I²S interface which means that both voice and audio cannot be routed at the same time.

1. The I²S port cannot be used at the application level for purposes other than routing A2DP audio samples.

6.13 PCM Interface

The CYW20719 includes a PCM interface that can connect to linear PCM codec devices in master or slave mode. In master mode, the CYW20719 generates the PCM_CLK and PCM_SYNC signals. In slave mode, these signals are provided by another device on the PCM interface and are inputs to the CYW20719. Some of the parameters of the PCM interface may be configured by the host.

The PCM interface is used for full-duplex bi-directional transfer of 8K or 16K voice samples from and to a SCO or eSCO connection². By default, the PCM interface runs in an I²S compatible mode, which allows the CYW20719 to transfer voice samples to I²S devices.

Note: PCM interface shares HW with the I²S interface which means that both voice and audio cannot be routed simultaneously.

6.13.1 Slot Mapping

The CYW20719 supports up to three simultaneous full-duplex SCO or eSCO channels through the PCM Interface. These three channels are time-multiplexed onto the single PCM interface by using a time-slotting scheme where the 8 kHz or 16 kHz voice sample interval is divided into as many as 16 slots. The number of slots is dependent on the selected interface rate (128 kHz, 256kHz, 512 kHz, 1024 kHz or 2048 kHz). The corresponding number of slots for these interface rate is 1, 2, 4, 8, and 16, respectively. Transmit and receive PCM data from an SCO channel is always mapped to the same slot. The PCM data output driver tristates its output on unused slots to allow other devices to share the same PCM interface signals. The data output driver tristates its output after the falling edge of the PCM clock during the last bit of the slot.

6.13.2 Frame Synchronization

The CYW20719 supports both short and long-frame synchronization in both master and slave modes and can be configured from the host. In short frame synchronization mode, the frame synchronization signal is an active-high pulse at the audio frame rate that is a single-bit period in width and is synchronized to the rising edge of the bit clock. The PCM slave looks for a high on the falling edge of the bit clock and expects the first bit of the first slot to start at the next rising edge of the clock. In long-frame synchronization mode, the frame synchronization signal is again an active-high pulse at the audio frame rate; however, the duration is three bit periods and the pulse starts coincident with the first bit of the first slot.

6.13.3 Data Formatting

The CYW20719 may be configured to generate or accept several different data formats. For conventional narrow band speech mode, the CYW20719 always uses 13 of the 16 bits in each PCM frame. The location and order of these 13 bits can be configured to support various data formats on the PCM interface. The remaining three bits are ignored on the input and may be filled with 0s, 1s, a sign bit, or a programmed value on the output. The default format is 13-bit 2's complement data, left justified, filled with 0's and clocked MSB first.

6.13.4 Burst PCM Mode

In this mode of operation, the PCM bus runs at a significantly higher rate of operation to allow the host to duty cycle its operation and save current. In this mode of operation, the PCM bus can operate at a rate of up to 24 MHz. This mode of operation is initiated with an HCI command from the host.

6.14 Security Engine

The CYW20719 includes a hardware security accelerator which greatly decreases the time required to perform typical security operations. This security engine includes:

- Public key acceleration (PKA) cryptography
- AES-CTR/CBC-MAC/CCM acceleration
- SHA2 message hash and HMAC acceleration
- RSA encryption and decryption of modulus sizes up to 2048 bits
- Elliptic curve Diffie-Hellman in prime field GF(p)

Note: Security engine is used only by Bluetooth stack to reduce CPU overhead. It is not available for application use

6.14.1 Random Number Generator

This hardware block is used for key generation for Bluetooth.

Note: Availability for use by the application is subject to the support in WICED® Studio.

2. The PCM interface cannot be used as a generic serial interface at the application level. It can only be used for routing SCO or eSCO voice samples.

6.15 Power Modes

The CYW20719 supports the following HW power modes:

- Active mode - Normal operating mode in which all peripherals are available and the CPU is active.
- Idle mode- In this mode, the CPU is in “Wait for Interrupt” (WFI) and the HCLK, which is the high frequency clock derived from the main crystal oscillator is running at a lower clock speed. Other clocks are active and the state of the entire chip is retained.
- Sleep mode - In this mode, CPU is in WFI and the HCLK is not running. The PMU determines if the other clocks can be turned off and does accordingly. State of the entire chip is retained, the internal LDOs run at a lower voltage (voltage is managed by the PMU), and SRAM is retained.
- Power Down Sleep (PDS) mode -This mode is an extension of the PMU Sleep wherein most of the peripherals such as UART and SPI are turned off. The entire memory is retained, and on wakeup the execution resumes from where it paused.
- Shut Down Sleep (SDS) mode -Everything is turned off except I/O Power Domain, RTC, and LPO. The device can come out of this mode either due to BT activity or by an external interrupt. Before going into this mode, the application can store some bytes of data into “Always On RAM” (AON). When the device comes out of this mode, the data from AON is restored. After waking from SDS, the application will start from the beginning (warmboot) and has to restore its state based on information stored in AON. In the SDS mode, a single BT task with no data activity, such as an ACL connection, BLE connection, or BLE advertisement can be performed.
- HID-OFF (Timed-Wake) mode -The device can enter this mode asynchronously, that is, the application can force the device into this mode at any time. I/O Power Domain, RTC, and LPO are the only active blocks. A timer that runs off the LPO is used to wake the device up after a predetermined fixed time.
- HID-OFF (External Interrupt-Waked) mode - This mode is similar to Timed-Wake, but in HID-OFF mode even the LPO and RTC are turned off. So, the only wakeup source is an external interrupt.

Transition between power modes is handled by the on-chip firmware with host/application involvement. Please see [Firmware](#) Section for details.

7. Firmware

The CYW20719 ROM firmware runs on a real time operating system and handles the programming and configuration of all on-chip hardware functions as well as the BT/LE baseband, Link Manager (LM), HCI, Generic Attribute Profile (GATT), Attribute Protocol (ATT), Logical Link Control and Adaptation Protocol (L2CAP) and Service Discovery Protocol (SDP) layers. The ROM also includes drivers for on-chip peripherals as well as handling on-chip power management functions including transitions between different power modes.

The CYW20719 is fully supported by the Cypress WICED® Studio platform. WICED releases provide latest ROM patches, drivers, and sample applications allowing customized applications using the CYW20719 to be built quickly and efficiently.

Please refer to WICED Technical Brief and CYW20719 Product Guide for details on the firmware architecture, driver documentation, power modes and how to write applications/profiles using the CYW20719.

8. Pin Assignments and GPIOs

This section addresses both QFN and WLCSP pin assignments and GPIOs for the CYW20719 device.

8.1 40-Pin QFN and WLCSP Pin Assignments

Table 4. 40-Pin QFN and WLCSP Pin Assignments

| Pin Name | Pin Number | | I/O | Power Domain | Description |
|------------------------|------------|---|-----|--------------|---|
| | QFN-40 | WLCSP | | | |
| Microphone | | | | | |
| ADC_avddBAT | – | 5 | I | VDDIO | VDDIO |
| ADC_AVDDC | – | 3 | I | – | No Connect |
| Mic_avdd | – | 19 | I | MIC_AVDD | Microphone supply |
| Micbias | – | 32 | I | MIC_AVDD | Microphone Bias Supply |
| Micn | – | 4 | I | MIC_AVDD | Microphone negative input |
| Micp | – | 18 | I | MIC_AVDD | Microphone positive input |
| ADC_AVSS | – | 34 | I | AVSS | Analog ground |
| ADC_AVSSC | – | 17 | I | AVSS | Analog ground |
| ADC_REFGND | – | 33 | I | AVSS | Analog reference ground |
| Mic_avss | – | 47 | I | AVSS | Microphone analog ground |
| Baseband Supply | | | | | |
| BT_VDDO | 25 | 1,8,9,11,14,26,29,42,56,66,91 | I | VDDO | I/O Pad Power supply |
| BT_VDDC | – | 2,43,58,74,99 | I/O | VDDC | Baseband core power supply |
| VDDO | 39 | - | I | VDDO | LHL PAD power supply. Can be tied to BT_VDDO. |
| RF Power Supply | | | | | |
| BT_PAVDD | 17 | 116 | I | PAVDD | PA supply |
| BT_PLLVDD1p2 | 21 | 106 | I | PLLVDD1P2 | RFPLL and crystal oscillator supply |
| BT_VCOVDD1p2 | 20 | 125 | I | VCOVDD1P2 | VCO supply |
| BT_IFVDD1P2 | 19 | 110 | I | IFVDD1P2 | IFPLL Power Supply |
| Onboard LDO's | | | | | |
| DIGLDO_VDDIN | 16 | 127 | I | | Internal Digital LDO input |
| DIGLDO_VDDOUT | – | 126 | O | | Internal Digital LDO output |
| RFLDO_VDDIN | 15 | 111 | I | – | RF LDO Input |
| RFLDO_VDDOUT | 14 | 128 | O | – | RF LDO Output |
| SR_VDDBAT3V | 13 | 129 | I | – | Core Buck Input |
| VDDBAT3V | – | 120 | I | – | Core Buck Input |
| SR_VLX | 12 | 121 | O | – | Core Buck Output |
| Ground Pins | | | | | |
| BT_PAVSS | – | 123 | I | VSS | Ground |
| BT_PLLVSS | – | 107 | I | VSS | Ground |
| BT_VCOVSS | – | 119 | I | VSS | Ground |
| BT_IFVSS | – | 115 | I | VSS | Ground |
| BT_VSSC | – | 30, 57, 75, 87, 117, 118, 124, 133, 134 | I | VSS | Ground |

Table 4. 40-Pin QFN and WLCSP Pin Assignments (Cont.)

| Pin Name | Pin Number | | I/O | Power Domain | Description |
|--------------------------|------------|---------------------------------|-------|--------------|--|
| | QFN-40 | WLCSP | | | |
| VSSC | – | 112 | I | VSS | Ground |
| VSSO_0 | – | 10,13, 25, 28,72, 96,101 | I | VSS | Ground |
| SR_PVSS | – | 130 | I | VSS | Ground |
| xtal_avss | – | 35 | I | XTAL_AVSS | Crystal ground |
| PMU_AVSS | – | 113 | I | PMU_AVSS | PMU ground |
| UART | | | | | |
| BT_UART_CTS_N | 30 | 15 | I, PU | VDDO | Clear to send (CTS) for HCI UART interface. Leave unconnected if not used. |
| BT_UART_RTS_N | 29 | 31 | O, PU | VDDO | Request to send (RTS) for HCI UART interface. Leave unconnected if not used. |
| BT_UART_RXD | 27 | 45 | I | VDDO | UART serial input. Serial data input for the HCI UART interface. |
| BT_UART_TXD | 28 | 46 | O, PU | VDDO | UART serial output. Serial data output for the HCI UART interface. |
| Crystal | | | | | |
| BT_XTALI | 22 | 105 | I | PLLVD1P2 | Crystal oscillator input. See “The XTAL must have an accuracy of ± 20 ppm as defined by the Bluetooth specification. Two external load capacitors are required to work with the crystal oscillator. The selection of the load capacitors is XTAL-dependent (see Figure 3)” for options. |
| BT_XTALO | 23 | 104 | O | PLLVD1P2 | Crystal oscillator output. |
| XTALI_32K | 32 | 6 | I | VDDO | Low-power oscillator input. |
| XTALO_32K | 31 | 20 | O | VDDO | Low-power oscillator output. |
| BT_RF | 18 | 132 | – | – | RF Antenna Port |
| BT_CLK_REQ | – | 68 | O | N/A | Used for shared-clock application. |
| JTAG_SEL | 11 | 102 | – | – | Reserved ARM JTAG debug mode control. Connect to GND for all applications. |
| RST_N | 10 | 103 | I | VDDO | Active-low system reset with internal pull-up resistor. |
| Reserved Pins | | | | | |
| Reserved | 26 | 21, 36, 49, 61, 77, 84, 85, 108 | N/A | N/A | Reserved. Leave unconnected. |
| Reserved, Connect to GND | – | 16, 92 | N/A | N/A | Reserved, connect to GND |

8.2 40-Pin QFN and WLCSP GPIOs

Table 5. 40-Pin QFN and WLCSP GPIOs

| Pin Name | Pin Number | | I/O | Power Domain | Description |
|--------------|------------|-------|-----|--------------|--|
| | QFN-40 | WLCSP | | | |
| BT_DEV_WAKE | – | 86 | I | VDDO | A signal from the host to the CYW20719 indicating that the host requires attention. |
| BT_HOST_WAKE | 24 | 76 | O | VDDO | A signal from the CYW20719 device to the host indicating that the Bluetooth device requires attention. |
| BT_GPIO_2 | – | 44 | I/O | VDDO | GPIO: Can also be configured as a GCI Pin |
| BT_GPIO_3 | – | 59 | I/O | VDDO | GPIO: Can also be configured as a GCI Pin |
| BT_GPIO_4 | – | 79 | I/O | VDDO | GPIO: Can also be configured as a GCI Pin |
| BT_GPIO_5 | – | 78 | I/O | VDDO | GPIO: Can also be configured as a GCI Pin |
| P0 | 3 | 93 | I/O | VDDO | <ul style="list-style-type: none"> ■ GPIO: P0 ■ Keyboard scan input (row): KSI0 ■ A/D converter input 29 ■ Supermux I/O functions as defined in Table 6. |
| P1 | 4 | 54 | I/O | VDDO | <ul style="list-style-type: none"> ■ GPIO: P1 ■ Keyboard scan input (row): KSI1 ■ A/D converter input 28 ■ Supermux I/O functions as defined in Table 6 |
| P2 | 34 | 60 | I/O | VDDO | <ul style="list-style-type: none"> ■ GPIO: P2 ■ Keyboard scan input (row): KSI2 ■ Supermux I/O functions as defined in Table 6 |
| P3 | – | 22 | I/O | VDDO | <ul style="list-style-type: none"> ■ GPIO: P3 ■ Keyboard scan input (row): KSI3 ■ Supermux I/O functions as defined in Table 6 |
| P4 | 35 | 23 | I/O | VDDO | <ul style="list-style-type: none"> ■ GPIO: P4 ■ Keyboard scan input (row): KSI4 ■ Supermux I/O functions as defined in Table 6 |
| P5 | – | 37 | I/O | VDDO | <ul style="list-style-type: none"> ■ GPIO: P5 ■ Keyboard scan input (row): KSI5 ■ Supermux I/O functions as defined in Table 6 |
| P6 | 36 | 50 | I/O | VDDO | <ul style="list-style-type: none"> ■ GPIO: P6 ■ Keyboard scan input (row): KSI6 ■ Supermux I/O functions as defined in Table 6 |
| P7 | 37 | 62 | I/O | VDDO | <ul style="list-style-type: none"> ■ GPIO: P7 ■ Keyboard scan input (row): KSI7 ■ Supermux I/O functions as defined in Table 6 |
| P8 | – | 69 | I/O | VDDO | <ul style="list-style-type: none"> ■ GPIO: P8 ■ A/D converter input 27 ■ Supermux I/O functions as defined in Table 6 |
| P9 | – | 52 | I/O | VDDO | <ul style="list-style-type: none"> ■ GPIO: P9 ■ A/D converter input 26 ■ External T/R switch control: tx_pd ■ Supermux I/O functions as defined in Table 6 |

Table 5. 40-Pin QFN and WLCSP GPIOs (Cont.)

| Pin Name | Pin Number | | I/O | Power Domain | Description |
|------------------|------------|-------|-----|--------------|--|
| | QFN-40 | WLCSP | | | |
| P10 | 40 | 63 | I/O | VDDO | <ul style="list-style-type: none"> ■ GPIO: P10 ■ Keyboard scan output (column): KSO2 ■ A/D converter input 25 ■ Supermux I/O functions as defined in Table 6 |
| P11 | 40 | 70 | I/O | VDDO | <ul style="list-style-type: none"> ■ GPIO: P11 ■ A/D converter input 24 ■ Supermux I/O functions as defined in Table 6 |
| P12 | – | 40 | I/O | VDDO | <ul style="list-style-type: none"> ■ GPIO: P12 ■ A/D converter input 23 ■ Supermux I/O functions as defined in Table 6 |
| P13 | 1 | 71 | I/O | VDDO | <ul style="list-style-type: none"> ■ GPIO: P13 ■ A/D converter input 22 ■ Supermux I/O functions as defined in Table 6 |
| P14 | – | 24 | I/O | VDDO | <ul style="list-style-type: none"> ■ GPIO: P14 ■ A/D converter input 21 ■ Supermux I/O functions as defined in Table 6 |
| P15 ^c | 32 | 7 | I/O | VDDO | <ul style="list-style-type: none"> ■ GPIO: P15 ■ A/D converter input 20 ■ Supermux I/O functions as defined in Table 12 |
| P16 | 33 | 48 | I/O | VDDO | <ul style="list-style-type: none"> ■ GPIO: P16 ■ A/D converter input 19 ■ Supermux I/O functions as defined in Table 6 |
| P17 | 38 | 38 | I/O | VDDO | <ul style="list-style-type: none"> ■ GPIO: P17 ■ A/D converter input 18 ■ Supermux I/O functions as defined in Table 6 |
| P18 | – | 51 | I/O | VDDO | <ul style="list-style-type: none"> ■ GPIO: P18 ■ A/D converter input 17 ■ Supermux I/O functions as defined in Table 6 |
| P19 | – | 39 | I/O | VDDO | <ul style="list-style-type: none"> ■ Reserved for system use. Leave unconnected. |
| P20 | – | 12 | I/O | VDDO | <ul style="list-style-type: none"> ■ Reserved for system use. Leave unconnected. |
| P21 | – | 53 | I/O | VDDO | <ul style="list-style-type: none"> ■ GPIO: P21 ■ A/D converter input 14 ■ Supermux I/O functions as defined in Table 6 |
| P22 | – | 27 | I/O | VDDO | <ul style="list-style-type: none"> ■ GPIO: P22 ■ A/D converter input 13 ■ Supermux I/O functions as defined in Table 6 |
| P23 | 1 | 64 | I/O | VDDO | <ul style="list-style-type: none"> ■ GPIO: P23 ■ A/D converter input 12 ■ Supermux I/O functions as defined in Table 6 |
| P24 | – | 90 | I/O | VDDO | <ul style="list-style-type: none"> ■ GPIO: P24 ■ Supermux I/O functions as defined in Table 6 |
| P25 | 8 | 97 | I/O | VDDO | <ul style="list-style-type: none"> ■ GPIO: P25 ■ Supermux I/O functions as defined in Table 6 |
| P26 | 7 | 83 | I/O | VDDO | <ul style="list-style-type: none"> ■ GPIO: P26 ■ Current: 16 mA sink ■ Supermux I/O functions as defined in Table 6 |

Table 5. 40-Pin QFN and WLCSP GPIOs (Cont.)

| Pin Name | Pin Number | | I/O | Power Domain | Description |
|-----------------------|------------|-------|-----|--------------|--|
| | QFN-40 | WLCSP | | | |
| P27 | – | 94 | I/O | VDDO | <ul style="list-style-type: none"> ■ GPIO: P27 ■ Current: 16 mA sink ■ Supermux I/O functions as defined in Table 6 |
| P28 | 1 | 41 | I/O | VDDO | <ul style="list-style-type: none"> ■ GPIO: P28 ■ A/D converter input 11 ■ Current: 16 mA sink ■ Supermux I/O functions as defined in Table 6 |
| P29 | 2 | 80 | I/O | VDDO | <ul style="list-style-type: none"> ■ GPIO: P29 ■ Optical control output: QOC3 ■ A/D converter input 10 ■ Current: 16 mA sink ■ Supermux I/O functions as defined in Table 6 |
| P30 | – | 95 | I/O | VDDO | <ul style="list-style-type: none"> ■ GPIO: P30 ■ A/D converter input 9 ■ Supermux I/O functions as defined in Table 6 |
| P31 | – | 73 | I/O | VDDO | <ul style="list-style-type: none"> ■ GPIO: P31 ■ A/D converter input 8 ■ Supermux I/O functions as defined in Table 6 |
| P32 | – | 98 | I/O | VDDO | <ul style="list-style-type: none"> ■ GPIO: P32 ■ A/D converter input 7 ■ Supermux I/O functions as defined in Table 6 |
| P33 | 9 | 100 | I/O | VDDO | <ul style="list-style-type: none"> ■ GPIO: P33 ■ A/D converter input 6 ■ Supermux I/O functions as defined in Table 6 |
| P34 | 5 | 81 | I/O | VDDO | <ul style="list-style-type: none"> ■ GPIO: P34 ■ A/D converter input 5 ■ Supermux I/O functions as defined in Table 6 |
| P35 | 5 | 65 | I/O | VDDO | <ul style="list-style-type: none"> ■ GPIO: P35 ■ A/D converter input 4 ■ Supermux I/O functions as defined in Table 6 |
| P36 | 5 | 55 | I/O | VDDO | <ul style="list-style-type: none"> ■ GPIO: P36 ■ A/D converter input 3 ■ Supermux I/O functions as defined in Table 6 |
| P37 ^c | – | 88 | I/O | VDDO | <ul style="list-style-type: none"> ■ GPIO: P37 ■ A/D converter input 2 ■ Supermux I/O functions as defined in Table 6 |
| P38 | 6 | 89 | I/O | VDDO | <ul style="list-style-type: none"> ■ GPIO: P38 ■ A/D converter input 1 ■ Supermux I/O functions as defined in Table 6 |
| P39 | – | 82 | I/O | VDDO | <ul style="list-style-type: none"> ■ Reserved for system use. Leave unconnected. |
| Strapping Pins | | | | | |
| BT_TM1 | – | 67 | I | – | Device test mode control. Connect to GND for all applications. |
| PMU_DISABLE | – | 109 | I | VDDO | PMU Enable/Disable. Connected to ground. |

a. All GPIOs are super mux. All GPIOs can be programmed for any alternative functions as listed in [Table 6](#) and [Table 7](#).

- b. During power-on reset, all inputs are disabled.
 c. P15 and P37 should not be driven high externally while the part is held in reset (they can be floating or driven low). Failure to do so may cause some current to flow through these pins until the part comes out of reset.

Table 6. GPIO Supermux Input Functions

| Input | Description |
|-----------------|------------------------------|
| SWDCK | Serial Wire Debugger Clock |
| SWDIO | Serial Wire Debugger I/O |
| spiffy1_clk[s] | SPIFFY 1 Clock (Slave) |
| spiffy1_cs[s] | SPIFFY 1 Chip Select (Slave) |
| spiffy1_mosi[s] | SPIFFY 1 MOSI (Slave) |
| spiffy1_miso[m] | SPIFFY 1 MISO (Master) |
| spiffy1_io2 | SPIFFY 1 I/O 2 (Quad SPI) |
| spiffy1_io3 | SPIFFY 1 I/O 3 (Quad SPI) |
| spiffy1_int[s] | SPIFFY 1 Interrupt (Slave) |
| spiffy2_clk[s] | SPIFFY 2 Clock (Slave) |
| spiffy2_cs[s] | SPIFFY 2 Chip Select (Slave) |
| spiffy2_mosi[s] | SPIFFY 2 MOSI (Slave) |
| spiffy2_miso[m] | SPIFFY 2 MISO (Master) |
| spiffy2_io2 | SPIFFY 2 I/O 2 |
| spiffy2_io3 | SPIFFY 2 I/O 3 |

Table 6. GPIO Supermux Input Functions (Cont.)

| Input | Description |
|----------------|----------------------------|
| spiffy2_int[s] | SPIFFY 2 Interrupt (Slave) |
| puart_rx | Peripheral UART RX |
| puart_cts_n | Peripheral UART CTS |
| SCL | I2C Clock |
| SDA | I2C Data |
| SCL2 | I2C2 Clock |
| SDA2 | I2C2 Data |
| PCM_IN | PCM Input |
| PCM_CLK | PCM Clock |
| PCM_SYNC | PCM Sync |
| I2S_DI | I2S Data Input |
| I2S_WS | I2S Word Select |
| I2S_CLK | I2S Clock |
| PDM_IN_Ch_1 | PDM Input Channel 1 |
| PDM_IN_Ch_2 | PDM Input Channel 2 |

Table 7. GPIO Supermux Output Functions

| Output | Description |
|--|----------------------------|
| do_P# (data out of GPIO. For example: 0) | |
| kso0 | Key Scan output 0 |
| kso1 | Key Scan output 1 |
| kso2 | Key Scan output 2 |
| kso3 | Key Scan output 3 |
| kso4 | Key Scan output 4 |
| kso5 | Key Scan output 5 |
| kso6 | Key Scan output 6 |
| kso7 | Key Scan output 7 |
| kso8 | Key Scan output 8 |
| kso9 | Key Scan output 9 |
| kso10 | Key Scan output 10 |
| kso11 | Key Scan output 11 |
| kso12 | Key Scan output 12 |
| kso13 | Key Scan output 13 |
| kso14 | Key Scan output 14 |
| kso15 | Key Scan output 15 |
| kso16 | Key Scan output 16 |
| kso17 | Key Scan output 17 |
| kso18 | Key Scan output 18 |
| kso19 | Key Scan output 19 |
| do_P# ^ pwm0 | PWM Channel 0 |
| do_P# ^ pwm1 | PWM Channel 1 |
| do_P# ^ pwm2 | PWM Channel 2 |
| do_P# ^ pwm3 | PWM Channel 3 |
| do_P# ^ pwm4 | PWM Channel 4 |
| do_P# ^ pwm5 | PWM Channel 5 |
| ack0 | Auxiliary clock Output 0 |
| ack1 | Auxiliary clock Output 1 |
| HID_OFF | HID-OFF Indicator |
| pa_ramp | External PA ramp |
| tx_pu | External PA Control Signal |

Table 7. GPIO Supermux Output Functions (Cont.)

| Output | Description |
|---------------------------|-----------------------------------|
| rx_pu | External PA Control Signal |
| SWDIO | Serial Wire Debugger Input/Output |
| SDA2 | I2C 2 Data |
| SCL2 | I2C 2 Clock |
| puart_tx (uart2_tx) | Peripheral UART TX |
| puart_rts_n (uart2_rts_n) | Peripheral UART RTS |
| spiffy1_CLK | SPIFFY 1 Clock |
| spiffy1_CS | SPIFFY 1 Chip Select |
| spiffy1_MOSI | SPIFFY 1 MOSI |
| spiffy1_MISO | SPIFFY 1 MISO |
| spiffy1_IO2 | SPIFFY I/O 2 |
| spiffy1_IO3 | SPIFFY I/O 3 |
| spiffy1_INT | SPIFFY Interrupt |
| spiffy1_DCX | MIPI-DBI Data/Command Indicator |
| spiffy2_CLK | SPIFFY 2 Clock |
| spiffy2_CS | SPIFFY 2 Chip Select |
| spiffy2_MOSI | SPIFFY 2 MOSI |
| spiffy2_MISO | SPIFFY 2 MISO |
| spiffy2_IO2 | SPIFFY 2 I/O 2 |
| spiffy2_IO3 | SPIFFY 2 I/O 3 |
| spiffy2_INT | SPIFFY 2 Interrupt |
| spiffy2_DCX | MIPI-DBI Data/Command Indicator |
| pcm_in_o | PCM IN |
| pcm_out_o | PCM Out |
| pcm_bclk_o | PCM Bit Clock |
| pcm_sync_o | PCM Sync Output |
| i2s_ssd | I2S Slave Serial Data |
| i2s_sws | I2S Slave Word Select |
| i2s_sck | I2S Slave Clock |
| i2s_msd | I2S Master Serial Data |
| i2s_mws | I2S Master Word Select |
| i2s_mck | I2S Master Clock |

9. Pin/Ball Maps

9.1 40-Pin QFN Pin Map

The CYW20719 40-pin QFN package is shown in [Figure 6](#).

Figure 6. 40-Pin QFN Pin Map

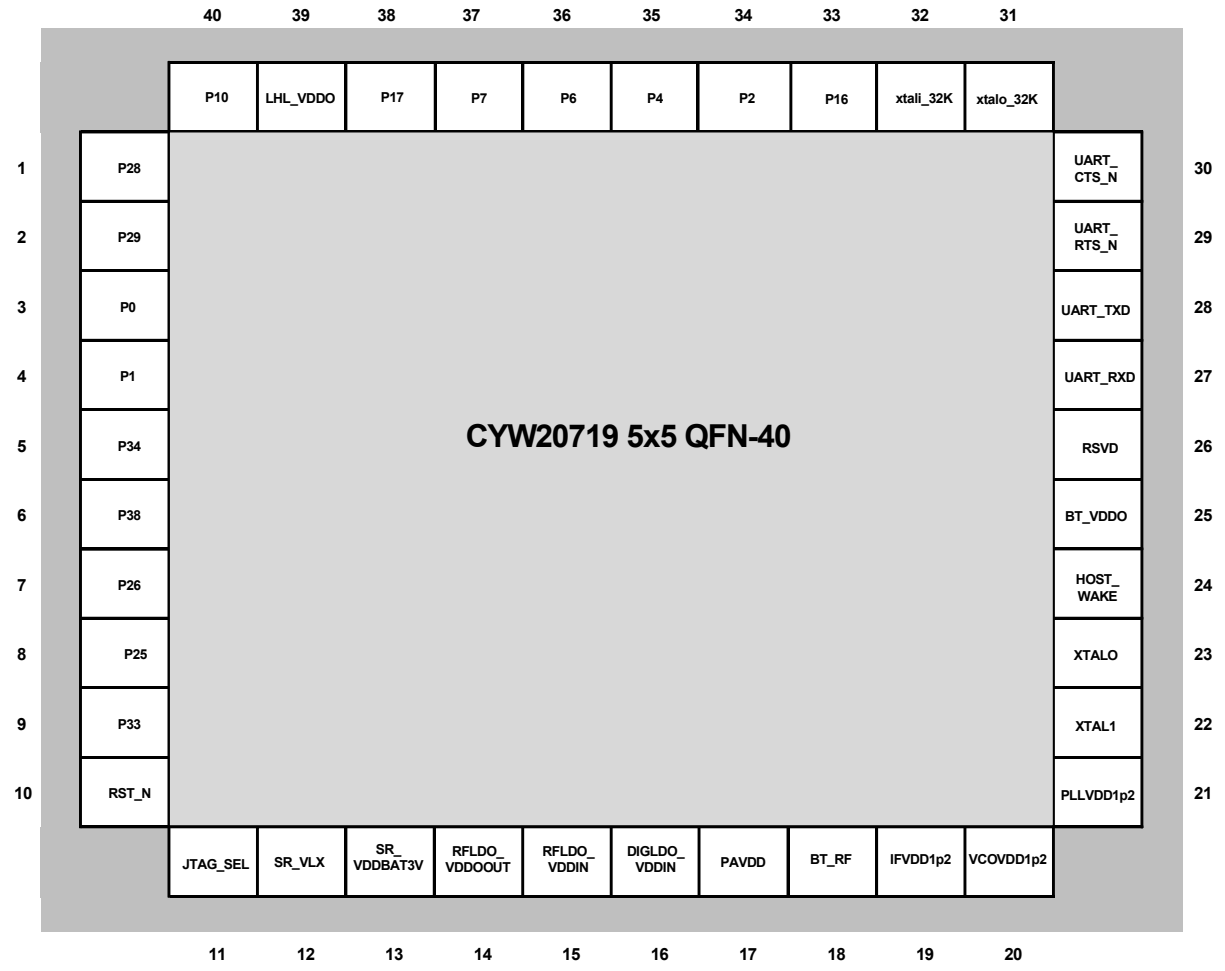

9.2 WLCSP Ball Map

The CYW20719 WLCSP package is shown in [Figure 7](#).

Figure 7. WLCSP Ball Map

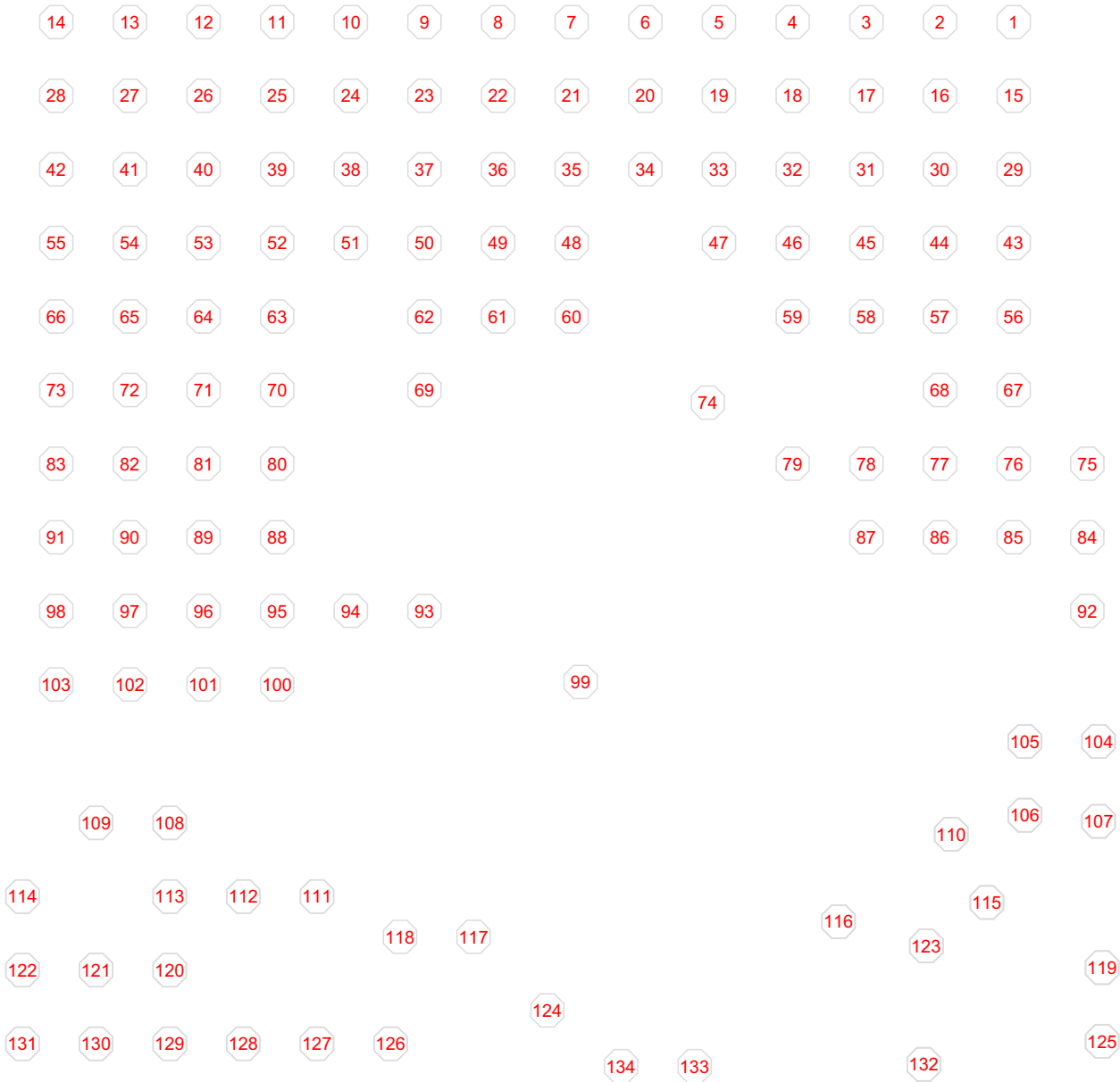

Notes:

- [Figure 7](#) shows the bottom view of the WLCSP package (Bumps facing up).
- See [Table 4](#) and [Table 9](#) and for additional WLCSP information.
- [Table 9](#) shows the package view from the bottom (bumps facing up).
- Coordinate origin (0, 0) is at the center of the WLCSP package with the bumps facing up.

Table 8. CYW20719 WLCSP Bump Coordinates

| Bump# | NET_NAME | X-COORD (μm) | Y-COORD (μm) |
|-------|---------------------------|--------------|--------------|
| 1 | BT_VDDO | 1232.28 | 1356.88 |
| 2 | BT_VDDC | 1032.28 | 1356.88 |
| 3 | Reserved - Do not connect | 832.28 | 1356.88 |
| 4 | Micn | 632.28 | 1356.88 |
| 5 | ADC_avddBAT | 432.28 | 1356.88 |
| 6 | xtali_32K | 232.29 | 1356.88 |
| 7 | P15 | 32.29 | 1356.88 |
| 8 | VDDO_0 | -167.7 | 1356.88 |
| 9 | VDDO_0 | -367.7 | 1356.88 |
| 10 | VSSO_0 | -567.7 | 1356.88 |
| 11 | VDDO_0 | -767.7 | 1356.88 |
| 12 | P20 | -967.69 | 1356.88 |
| 13 | VSSO_0 | -1167.69 | 1356.88 |
| 14 | VDDO_0 | -1367.69 | 1356.88 |
| 15 | BT_UART_CTS_N | 1232.28 | 1156.88 |
| 16 | Reserved, Connect to GND | 1032.28 | 1156.88 |
| 17 | ADC_AVSSC | 832.28 | 1156.88 |
| 18 | Micp | 632.28 | 1156.88 |
| 19 | Mic_avdd | 432.28 | 1156.88 |
| 20 | xtalo_32K | 232.29 | 1156.88 |
| 21 | Reserved | 32.29 | 1156.88 |
| 22 | P3 | -167.7 | 1156.88 |
| 23 | P4 | -367.7 | 1156.88 |
| 24 | P14 | -567.7 | 1156.88 |
| 25 | VSSO_0 | -767.7 | 1156.88 |
| 26 | VDDO_0 | -967.69 | 1156.88 |
| 27 | P22 | -1167.69 | 1156.88 |
| 28 | VSSO_0 | -1367.69 | 1156.88 |
| 29 | BT_VDDO | 1232.28 | 956.88 |
| 30 | BT_VSSC | 1032.28 | 956.88 |
| 31 | BT_UART_RTS_N | 832.28 | 956.88 |
| 32 | Micbias | 632.28 | 956.88 |
| 33 | ADC_REFGND | 432.28 | 956.88 |
| 34 | ADC_AVSS | 232.29 | 956.88 |
| 35 | xtal_avss | 32.29 | 956.88 |
| 36 | Reserved | -167.7 | 956.88 |
| 37 | P5 | -367.7 | 956.88 |
| 38 | P17 | -567.7 | 956.88 |
| 39 | P19 | -767.7 | 956.88 |
| 40 | P12 | -967.69 | 956.88 |
| 41 | P28 | -1167.69 | 956.88 |
| 42 | VDDO_0 | -1367.69 | 956.88 |

Table 8. CYW20719 WLCSP Bump Coordinates (Cont.)

| Bump# | NET_NAME | X-COORD (µm) | Y-COORD (µm) |
|-------|--------------|--------------|--------------|
| 43 | BT_VDDC | 1232.28 | 756.89 |
| 44 | BT_GPIO_2 | 1032.28 | 756.89 |
| 45 | BT_UART_RXD | 832.28 | 756.89 |
| 46 | BT_UART_TXD | 632.28 | 756.89 |
| 47 | Mic_avss | 432.28 | 756.89 |
| 48 | P16 | 32.29 | 756.89 |
| 49 | Reserved | -167.7 | 756.89 |
| 50 | P6 | -367.7 | 756.89 |
| 51 | P18 | -567.7 | 756.89 |
| 52 | P9 | -767.7 | 756.89 |
| 53 | P21 | -967.69 | 756.89 |
| 54 | P1 | -1167.69 | 756.89 |
| 55 | P36 | -1367.69 | 756.89 |
| 56 | BT_VDDO | 1232.28 | 556.89 |
| 57 | BT_VSSC | 1032.28 | 556.89 |
| 58 | BT_VDDC | 832.28 | 556.89 |
| 59 | BT_GPIO_3 | 632.28 | 556.89 |
| 60 | P2 | 32.29 | 556.89 |
| 61 | Reserved | -167.7 | 556.89 |
| 62 | P7 | -367.7 | 556.89 |
| 63 | P10 | -767.7 | 556.89 |
| 64 | P23 | -967.69 | 556.89 |
| 65 | P35 | -1167.69 | 556.89 |
| 66 | VDDO_0 | -1367.69 | 556.89 |
| 67 | BT_TM1 | 1232.28 | 356.89 |
| 68 | BT_CLK_REQ | 1032.28 | 356.89 |
| 69 | P8 | -367.7 | 356.89 |
| 70 | P11 | -767.7 | 356.89 |
| 71 | P13 | -967.69 | 356.89 |
| 72 | VSSO_0 | -1167.69 | 356.89 |
| 73 | P31 | -1367.69 | 356.89 |
| 74 | BT_VDDC | 401.88 | 322.94 |
| 75 | BT_VSSC | 1432.27 | 156.89 |
| 76 | BT_HOST_WAKE | 1232.28 | 156.89 |
| 77 | Reserved | 1032.28 | 156.89 |
| 78 | BT_GPIO_5 | 832.28 | 156.89 |
| 79 | BT_GPIO_4 | 632.28 | 156.89 |
| 80 | P29 | -767.7 | 156.89 |
| 81 | P34 | -967.69 | 156.89 |
| 82 | P39 | -1167.69 | 156.89 |
| 83 | P26 | -1367.69 | 156.89 |
| 84 | Reserved | 1432.27 | -43.1 |

Table 8. CYW20719 WLCSP Bump Coordinates (Cont.)

| Bump# | NET_NAME | X-COORD (µm) | Y-COORD (µm) |
|-------|--------------------------|--------------|--------------|
| 85 | Reserved | 1232.28 | -43.1 |
| 86 | BT_DEV_WAKE | 1032.28 | -43.1 |
| 87 | BT_VSSC | 832.28 | -43.1 |
| 88 | P37 | -767.7 | -43.1 |
| 89 | P38 | -967.69 | -43.1 |
| 90 | P24 | -1167.69 | -43.1 |
| 91 | VDDO_0 | -1367.69 | -43.1 |
| 92 | Reserved, Connect to GND | 1432.27 | -243.09 |
| 93 | P0 | -367.7 | -243.09 |
| 94 | P27 | -567.7 | -243.09 |
| 95 | P30 | -767.7 | -243.09 |
| 96 | VSSO_0 | -967.69 | -243.09 |
| 97 | P25 | -1167.69 | -243.09 |
| 98 | P32 | -1367.69 | -243.09 |
| 99 | BT_VDDC | 56.23 | -435.87 |
| 100 | P33 | -767.7 | -443.09 |
| 101 | VSSO_0 | -967.69 | -443.09 |
| 102 | JTAG_SEL | -1167.69 | -443.09 |
| 103 | RST_N | -1367.69 | -443.09 |
| 104 | BT_XTALO | 1462.79 | -597.97 |
| 105 | BT_XTALI | 1262.79 | -597.97 |
| 106 | BT_PLLVDD1p2 | 1262.79 | -797.97 |
| 107 | BT_PLLVSS | 1462.79 | -814.63 |
| 108 | Reserved | -1059.5 | -819 |
| 109 | PMU_DISABLE | -1259.5 | -819 |
| 110 | BT_IFVDD1p2 | 1062.79 | -849.66 |
| 111 | RFLDO_VDDIN1P5 | -659.5 | -1018.99 |
| 112 | VSSC | -859.5 | -1018.99 |
| 113 | PMU_AVSS | -1059.5 | -1018.99 |
| 114 | PMU_AVSS | -1459.49 | -1018.99 |
| 115 | BT_IFVSS | 1159.51 | -1035.5 |
| 116 | BT_PAVDD | 756.99 | -1087.29 |
| 117 | BT_VSSC | -234 | -1128.6 |
| 118 | BT_VSSC | -433.99 | -1128.6 |
| 119 | BT_VCOVSS | 1472.59 | -1212.28 |
| 120 | VDDBAT3V | -1059.5 | -1218.99 |
| 121 | SR_VLX | -1259.5 | -1218.99 |
| 122 | Reserved | -1459.49 | -1218.99 |
| 123 | BT_PAVSS | 994.94 | -1153.5 |
| 124 | BT_VSSC | -34 | -1328.59 |
| 125 | BT_VCOVDD1p2 | 1472.59 | -1412.28 |
| 126 | DIGLDO_VDDOUT | -459.5 | -1418.99 |

Table 8. CYW20719 WLCSP Bump Coordinates (Cont.)

| Bump# | NET_NAME | X-COORD (μm) | Y-COORD (μm) |
|--------------|-----------------|---------------------|---------------------|
| 127 | DIGLDO_VDDIN1P5 | -659.5 | -1418.99 |
| 128 | RFLDO_VDDOUT | -859.5 | -1418.99 |
| 129 | SR_VDDBAT3V | -1059.5 | -1418.99 |
| 130 | SR_PVSS | -1259.5 | -1418.99 |
| 131 | Reserved | -1459.49 | -1418.99 |
| 132 | BT_RF | 988.31 | -1475 |
| 133 | BT_VSSC | 365.99 | -1479.96 |
| 134 | BT_VSSC | 165.99 | -1479.96 |

10. Specifications

10.1 Electrical Characteristics

Caution! The absolute maximum ratings in the following table indicate levels where permanent damage to the device can occur, even if these limits are exceeded for only a brief duration. Functional operation is not guaranteed under these conditions. Operation at absolute maximum conditions for extended periods can adversely affect long-term reliability of the device.

Table 9. Absolute Maximum Ratings

| Requirement Parameter | Specification | | | Unit |
|--|---------------|------|-------|------|
| | Min. | Nom. | Max. | |
| Maximum Junction Temperature | – | – | 125 | °C |
| VDD IO (BT_VDDO, VDDO_0) | –0.5 | – | 3.795 | V |
| VDD RF (BT_IFVDD1p2, BT_PLLVDD1p2, BT_VCOVDD1p2, BT_PAVDD) | –0.5 | – | 1.38 | V |
| VDDBAT3V/SR_VDDBAT3V | –0.5 | – | 3.795 | V |
| DIGLDO_VDDIN1P5 | –0.5 | – | 1.65 | V |
| RFLDO_VDDIN1P5 | –0.5 | – | 1.50 | V |
| MIC_AVDD | –0.5 | – | 3.795 | V |

Table 10. ESD/Latch up

| Requirement Parameter | Specification | | | Unit |
|-----------------------|---------------|------|------|------|
| | Min. | Nom. | Max. | |
| ESD Tolerance HBM | –2000 | – | 2000 | V |
| ESD Tolerance CDM | –500 | – | 500 | V |
| Latch up | – | 200 | – | mA |

Table 11. Environmental Ratings

| Characteristic | Value | Units |
|-----------------------|-------------|-------|
| Operating Temperature | –30 to +85 | °C |
| Storage Temperature | –40 to +150 | °C |

Note:

Lowest operating temperature for the 32 KHz xtal is -10°C

Table 12. Recommended Operating Conditions

| Parameter | Specification | | | Unit |
|---|---------------|------|------|------|
| | Min. | Typ. | Max. | |
| VDDIO (BT_VDDO, VDDO_0) | 1.76 | 3.0 | 3.63 | V |
| VDDBAT3V ^a /SR_VDDBAT3V ^a | 1.9 | 3.0 | 3.63 | V |
| MIC_AVDD | 1.76 | 3.0 | 3.63 | V |

a. Supply tolerance for VDDBAT3V and SR_VDDBAT3V must be 2% or less.

The CYW20719 uses an on board low voltage detector to shut down the part when supply voltage (VDDBAT3V) drops below operating range.

Table 13. Shutdown Voltage

| Parameter | Specification | | | Unit |
|-------------------|---------------|------|------|------|
| | Min. | Typ. | Max. | |
| V _{SHUT} | 1.625 | 1.7 | 1.76 | V |

10.1.1 Core Buck Regulator

Table 14. Core Buck Regulator

| Parameter | Conditions | Min. | Typ. | Max. | Unit |
|-----------------------------------|--|------|------|------|------|
| Input supply voltage DC, VBAT | DC voltage range inclusive of disturbances | 1.9 | 3.0 | 3.63 | V |
| CBUCK output current | Low Power Operation Mode (LPOM) only | – | – | 65 | mA |
| Output voltage range | Programmable, 30mV/step default = 1.2 V (bits = 0000) | 1.2 | 1.26 | 1.5 | V |
| Output voltage DC accuracy | Includes load and line regulation | –4 | – | +4 | % |
| LPOM efficiency (high load) | – | – | 85 | – | % |
| LPOM efficiency (low load) | – | – | 80 | – | % |
| Input supply voltage ramp-up time | 0 to 3.3 V | 40 | – | – | µs |

- Minimum capacitor value refers to residual capacitor value after taking into account part-to-part tolerance, DC-bias, temperature, and aging.
- Maximum capacitor value refers to the total capacitance seen at a node where the capacitor is connected. This also includes any decoupling capacitors connected at the load side, if any.

10.1.2 Recommended External Component for Core Buck Regulator

Table 15. Recommended External Component for Core Buck Regulator

| Parameter | Conditions | Min. | Typ. | Max. | Unit |
|---------------------------------|---|------|------|------|------|
| External output inductor L | 2.2 µH ±25%, DCR=114 mΩ ±20%, ACR<1Ω (for frequency<1 MHz) | – | 2.2 | – | µH |
| External output capacitor, Cout | 4.7 µF ±10%, 6.3V, 0402 inch, X5R, MLCC capacitor +board total-ESR < 20 mΩ | – | 4.7 | – | µF |
| External input capacitor, Cin | For SR_VDDBAT pin Ceramic, X5R, 0402, ESR<30 mΩ at 4 MHz, +/-20%, 6.3V, 10 µF | – | 10 | – | µF |

10.1.3 Recommended External Components for RFLDO

Table 16. Recommended External Components for RFLDO

| Parameter | Conditions | Min. | Typ. | Max. | Unit |
|-------------------------------|-----------------------------------|------|------|------|------|
| External output capacitor, Co | Total ESR (trace/cap): 5 m–240 mΩ | 0.5 | 2.2 | 4.7 | µF |

10.1.4 Digital I/O Characteristics

Table 17. Digital I/O Characteristics

| Characteristics | Symbol | Minimum | Typical | Maximum | Unit |
|---|----------|---------------|---------|---------|---------|
| Input low voltage (VDDO = 3 V) | V_{IL} | – | – | 0.8 | V |
| Input high voltage (VDDO = 3 V) | V_{IH} | 2.4 | – | – | V |
| Input low voltage (VDDO = 1.8 V) | V_{IL} | – | – | 0.4 | V |
| Input high voltage (VDDO = 1.8 V) | V_{IH} | 1.4 | – | – | V |
| Output low voltage | V_{OL} | – | – | 0.45 | V |
| Output high voltage | V_{OH} | VDDO – 0.45 V | – | – | V |
| Input low current | I_{IL} | – | – | 1.0 | μ A |
| Input high current | I_{IH} | – | – | 1.0 | μ A |
| Input capacitance | C_{IN} | – | – | 0.4 | pF |
| Output low current (VDDO = 3 V, V_{OL} = 0.5 V) | I_{OL} | – | – | 8.0 | mA |
| Output low current (VDDO = 1.8 V, V_{OL} = 0.5 V) | I_{OL} | – | – | 4.0 | mA |
| Output high current (VDDO = 3 V, V_{OH} = 2.55 V) | I_{OH} | – | – | 8.0 | mA |
| Output high current (VDDO = 1.8 V, V_{OH} = 1.35 V) | I_{OH} | – | – | 4.0 | mA |

10.1.5 ADC Electrical Characteristics

Table 18. Electrical Characteristics

| Parameter | Symbol | Conditions/Comments | Min. | Typ. | Max. | Unit |
|--------------------------|-----------|--|------|------|------|------------|
| Current consumption | I_{TOT} | – | – | 2 | 3 | mA |
| Power down current | – | At room temperature | – | 1 | – | μ A |
| ADC Core Specification | | | | | | |
| ADC reference voltage | VREF | From BG with $\pm 3\%$ accuracy | – | 0.85 | – | V |
| ADC sampling clock | – | – | – | 12 | – | MHz |
| Absolute error | – | Includes gain error, offset and distortion. Without factory calibration. | – | – | 5 | % |
| | | Includes gain error, offset and distortion. After factory calibration. | – | – | 2 | % |
| ENOB | – | For audio application | 12 | 13 | – | Bit |
| | | For static measurement | 10 | – | – | |
| ADC input full scale | FS | For audio application | – | 1.6 | – | |
| | | For static measurement | 1.8 | – | 3.6 | |
| Conversion rate | – | For audio application | 8 | 16 | – | kHz |
| Signal bandwidth | – | For audio application | 20 | – | 8K | Hz |
| | | For static measurement | – | DC | – | |
| Input impedance | R_{IN} | For audio application | 10 | – | – | K Ω |
| | | For static measurement | 500 | – | – | |
| Startup time | – | For audio application | – | 10 | – | ms |
| | | For static measurement | – | 20 | – | μ s |
| MIC PGA Specifications | | | | | | |
| MIC PGA gain range | – | – | 0 | – | 42 | dB |
| MIC PGA gain step | – | – | – | 1 | – | dB |
| PGA input referred noise | – | At 42 dB PGA gain A-weighted | – | – | 4 | μ V |

Table 18. Electrical Characteristics (Cont.)

| Parameter | Symbol | Conditions/Comments | Min. | Typ. | Max. | Unit |
|------------------------------------|--------|--|------|------|------|------|
| MIC Bias Specifications | | | | | | |
| MIC bias output voltage | – | At 3 V supply, 25°C, default settings | – | 2.4 | – | V |
| MIC bias loading current | – | – | – | – | 3 | mA |
| MIC bias noise | – | Refers to PGA input 20 Hz to 8 kHz, A-weighted | – | – | 3 | µV |
| MIC bias PSRR | – | at 1 kHz | 40 | – | – | dB |
| ADC SNR | – | A-weighted 0 dB PGA gain, Temperature= 25°C | – | 78 | – | dB |
| ADC THD + N | – | –3 dBFS input 0 dB PGA gain, Temperature= 25°C | – | 70 | – | dB |
| GPIO input voltage | | Always lower than avddBAT | – | – | 3.6 | V |
| GPIO source impedance ^a | – | Resistance | – | – | 1 | kΩ |
| | | Capacitance | – | – | 10 | pF |

a. Conditional requirement for the measurement time of 10 µs. Relaxed with longer measurement time for each GPIO input channel.

10.1.6 Current Consumption

In [Table 19](#), current consumption measurements are taken at input of VBAT and VDDIO combined (LDOIN = VDDIO = 3.0V).

Table 19. Current Consumption BT/LE

| Operational Mode | Conditions | Typical | Unit |
|------------------------------|--|---------|------|
| HCI | 48 MHz with Pause | 1.1 | mA |
| | 48 MHz Without Pause | 2.2 | mA |
| RX | Continuous RX | 5.9 | mA |
| TX | Continuous TX - 0 dBm | 5.6 | mA |
| PDS | | 61 | µA |
| HID-Off | 32 KHz XTAL and 16 KB Retention RAM on | 1.6 | µA |
| Advertising | Unconnectable - 1 sec | 14 | µA |
| | Connectable undirected - 1 sec | 17 | µA |
| LE Connection - SDS | Master - 1 sec | TBD | µA |
| | Slave - 1 sec | TBD | µA |
| Page Scan - PDS | Interlaced - R1 | 122 | µA |
| Sniff - PDS | 500 ms Sniff, 1 attempt, 0 timeout - Master | 132 | µA |
| | 500 ms Sniff, 1 attempt, 0 timeout - Slave | 138 | µA |
| Bi-Directional Data Exchange | Continuous DM5 or DH5 packets - Master/Slave | 6.9 | mA |

10.2 RF Specifications

Note: Table 20 and Table 21 apply to single-ended industrial temperatures. Unused inputs are left open.

Table 20. Receiver RF Specifications

| Parameter | Mode and Conditions | Min | Typ | Max | Unit |
|--|---------------------------------------|------|--------------------|-------|------|
| Frequency range | – | 2402 | – | 2480 | MHz |
| RX sensitivity (QFN) ^a | GFSK, 0.1% BER, 1 Mbps | – | –92.0 ^b | – | dBm |
| | $\pi/4$ -DQPSK, 0.01% BER, 2 Mbps | – | –94.0 ^b | – | dBm |
| | 8-DPSK, 0.01% BER, 3 Mbps | – | –88.0 ^b | – | dBm |
| RX sensitivity (WLCSP) ^a | GFSK, 0.1% BER, 1 Mbps | – | –91.5 ^b | – | dBm |
| | $\pi/4$ -DQPSK, 0.01% BER, 2 Mbps | – | –93.5 ^b | – | dBm |
| | 8-DPSK, 0.01% BER, 3 Mbps | – | –87.5 ^b | – | dBm |
| Maximum input | All data rates | – | – | –20 | dBm |
| GFSK Modulation | | | | | |
| C/I cochannel | GFSK, 0.1% BER ^c | – | – | 11.0 | dB |
| C/I 1 MHz adjacent channel | GFSK, 0.1% BER ^d | – | – | 0 | dB |
| C/I 2 MHz adjacent channel | GFSK, 0.1% BER ^c | – | – | –30.0 | dB |
| C/I \geq 3 MHz adjacent channel | GFSK, 0.1% BER ^e | – | – | –40.0 | dB |
| C/I image channel | GFSK, 0.1% BER ^c | – | – | –9.0 | dB |
| C/I 1 MHz adjacent to image channel | GFSK, 0.1% BER ^c | – | – | –20.0 | dB |
| QPSK Modulation | | | | | |
| C/I cochannel | $\pi/4$ -DQPSK, 0.1% BER ^c | – | – | 13.0 | dB |
| C/I 1 MHz adjacent channel | $\pi/4$ -DQPSK, 0.1% BER ^d | – | – | 0 | dB |
| C/I 2 MHz adjacent channel | $\pi/4$ -DQPSK, 0.1% BER ^c | – | – | –30.0 | dB |
| C/I \geq 3 MHz adjacent channel | $\pi/4$ -DQPSK, 0.1% BER ^e | – | – | –40.0 | dB |
| C/I image channel | $\pi/4$ -DQPSK, 0.1% BER ^c | – | – | –9.0 | dB |
| C/I 1 MHz adjacent to image channel | $\pi/4$ -DQPSK, 0.1% BER ^c | – | – | –20.0 | dB |
| 8PSK Modulation | | | | | |
| C/I cochannel | 8-DPSK, 0.1% BER ^c | – | – | 21.0 | dB |
| C/I 1 MHz adjacent channel | 8-DPSK, 0.1% BER ^c | – | – | 5.0 | dB |
| C/I 2 MHz adjacent channel | 8-DPSK, 0.1% BER ^c | – | – | –25.0 | dB |
| C/I \geq 3 MHz adjacent channel | 8-DPSK, 0.1% BER ^e | – | – | –33.0 | dB |
| C/I image channel | 8-DPSK, 0.1% BER ^c | – | – | 0 | dB |
| C/I 1 MHz adjacent to image channel | 8-DPSK, 0.1% BER ^c | – | – | 13 | dB |
| Out-of-Band Blocking Performance (CW)^d | | | | | |
| 30 MHz to 2000 MHz | BDR GFSK 0.1% BER | – | –10.0 | – | dBm |
| 2000 MHz to 2399 MHz | BDR GFSK 0.1% BER | – | –27.0 | – | dBm |
| 2498 MHz to 3000 MHz | BDR GFSK 0.1% BER | – | –27.0 | – | dBm |
| 3000 MHz to 12.75 GHz | BDR GFSK 0.1% BER | – | –10.0 | – | dBm |
| Inter-modulation Performance^f | | | | | |
| BT, interferer signal level | BDR GFSK 0.1% BER | – | – | –39.0 | dBm |
| Spurious Emissions | | | | | |
| 30 MHz to 1 GHz | – | – | – | –57.0 | dBm |
| 1 GHz to 12.75 GHz | – | – | – | –55.0 | dBm |

a. Dirty TX is off

b. Up to 1dB of variation may potentially be seen from typical sensitivity specs due to the chip, board and associated variations

- c. The receiver sensitivity is measured at BER of 0.1% on the device interface.
- d. Desired signal is 10 dB above the reference sensitivity level (defined as -70 dBm).
- e. Desired signal is 3 dB above the reference sensitivity level (defined as -70 dBm).
- f. Desired signal is -64 dBm Bluetooth-modulated signal, interferer 1 is -39 dBm sine wave at frequency f1, interferer 2 is -39 dBm Bluetooth modulated signal at frequency f2, $f_0 = 2*f_1 - f_2$, and $|f_2 - f_1| = n*1$ MHz, where n is 3, 4, or 5. For the typical case, n = 4.

Table 21. Transmitter RF Specifications

| Parameter | Min | Typ | Max | Unit |
|--|------|-----|-------|----------------|
| Transmitter Section | | | | |
| Frequency range | 2402 | – | 2480 | MHz |
| Class 2: GFSK TX power | – | 4.0 | – | dBm |
| Class2: EDR TX Power | – | 0 | – | dBm |
| 20 dB bandwidth | – | 930 | 1000 | kHz |
| Adjacent Channel Power | | | | |
| $ M - N = 2$ | – | – | -20 | dBm |
| $ M - N \geq 3$ | – | – | -40 | dBm |
| Out-of-Band Spurious Emission | | | | |
| 30 MHz to 1 GHz | – | – | -36.0 | dBm |
| 1 GHz to 12.75 GHz | – | – | -30.0 | dBm |
| 1.8 GHz to 1.9 GHz | – | – | -47.0 | dBm |
| 5.15 GHz to 5.3 GHz | – | – | -47.0 | dBm |
| LO Performance | | | | |
| Initial carrier frequency tolerance | -75 | – | +75 | kHz |
| Frequency Drift | | | | |
| DH1 packet | -25 | – | +25 | kHz |
| DH3 packet | -40 | – | +40 | kHz |
| DH5 packet | -40 | – | +40 | kHz |
| Drift rate | -20 | – | 20 | kHz/50 μ s |
| Frequency Deviation | | | | |
| Average deviation in payload (sequence used is 00001111) | 140 | – | 175 | kHz |
| Maximum deviation in payload (sequence used is 10101010) | 115 | – | – | kHz |
| Channel spacing | – | 1 | – | MHz |
| Modulation Accuracy | | | | |
| p/4-DQPSK Frequency Stability | -10 | – | 10 | kHz |
| p/4-DQPSK RMS DEVM | – | – | 20 | % |
| p/4-QPSK Peak DEVM | – | – | 35 | % |
| p/4-DQPSK 99% DEVM | – | – | 30 | % |
| 8-DPSK frequency stability | -10 | – | 10 | kHz |
| 8-DPSK RMS DEVM | – | – | 13 | % |
| 8-DPSK Peak DEVM | – | – | 25 | % |
| 8-DPSK 99% DEVM | – | – | 20 | % |
| In-Band Spurious Emissions | | | | |
| 1.0 MHz < $ M - N $ < 1.5 MHz | – | – | -26 | dBc |
| 1.5 MHz < $ M - N $ < 2.5 MHz | – | – | -20 | dBm |
| $ M - N > 2.5$ MHz | – | – | -40 | dBm |

Table 22. BLE RF Specifications

| Parameter | Conditions | Minimum | Typical | Maximum | Unit |
|-------------------------------------|---------------------------|---------|--------------------|---------|------|
| Frequency range | N/A | 2402 | – | 2480 | MHz |
| RX sensitivity (QFN) ^a | LE GFSK, 0.1% BER, 1 Mbps | – | –95.0 ^b | – | dBm |
| RX sensitivity (WLCSP) ^a | LE GFSK, 0.1% BER, 1 Mbps | – | –94.5 ^b | – | dBm |
| TX power | N/A | – | 4.0 | – | dBm |
| Mod Char: Delta F1 average | N/A | 225 | 255 | 275 | kHz |
| Mod Char: Delta F2 max ^c | N/A | 99.9 | – | – | % |
| Mod Char: Ratio | N/A | 0.8 | 0.95 | – | % |

a. Dirty Tx is Off

b. Up to 1dB of variation may potentially be seen from typical sensitivity specs due to the chip, board and associated variations

c. At least 99.9% of all delta F2 max frequency values recorded over 10 packets must be greater than 185 kHz.

Table 23. BLE2M RF Specifications

| Parameter | Condition | Min. | Typ. | Max. | Unit |
|-----------------------------|-------------|------|-------|------|----------|
| Frequency Range | N/A | 2402 | | 2480 | MHz |
| RX Sensitivity ^a | 255 Packets | - | -90.5 | - | dBm |
| TX Power | N/A | - | 4 | - | dBm |
| Mod Char: Delta F1 average | N/A | 450 | 500 | 550 | KHz |
| Mod Char: Delta F2 max | N/A | 370 | - | - | KHz |
| Mod Char: Ratio | N/A | 0.8 | - | - | % |
| Frequency Drift | N/A | -50 | - | 50 | KHz |
| Drift Rate | N/A | -20 | - | 20 | KHz/50µs |

a. Dirty TX is OFF.

Table 24. CYW20719 GPS and GLONASS Band Spurious Emission

| Parameter | Condition | Min. | Typ. | Max. | Unit |
|---------------|-----------|------|------|------|--------|
| 1570-1580 MHz | GPS | – | –160 | – | dBm/Hz |
| 1592-1610 MHz | GLONASS | – | –159 | – | dBm/Hz |

10.3 Timing and AC Characteristics

In this section, use the numbers listed in the Reference column of each table to interpret the following timing diagrams.

10.3.1 UART Timing

Table 25. UART Timing Specifications

| Reference | Characteristics | Min. | Typ. | Max. | Unit |
|-----------|---|------|------|------|-------------|
| 1 | Delay time, UART_CTS_N low to UART_TXD valid | – | – | 1.50 | Bit periods |
| 2 | Setup time, UART_CTS_N high before midpoint of stop bit | – | – | 0.67 | Bit periods |
| 3 | Delay time, midpoint of stop bit to UART_RTS_N HIGH | – | – | 1.33 | Bit periods |

Figure 8. UART Timing

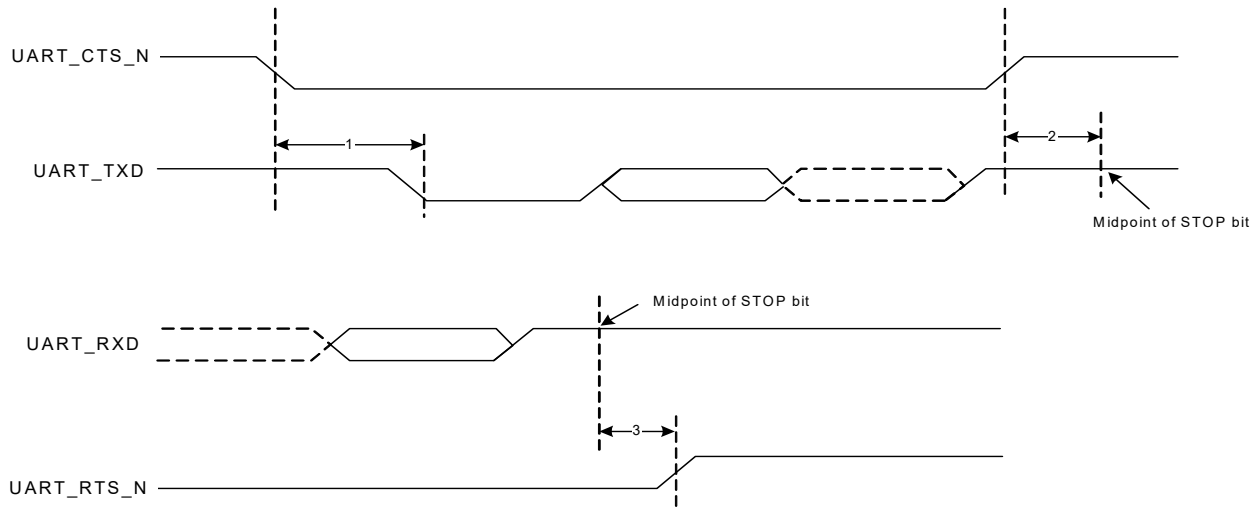

10.3.2 SPI Timing

The SPI interface can be clocked up to 24 MHz.

Table 26 and Figure 9 show the timing requirements when operating in SPI Mode 0 and 2.

Table 26. SPI Mode 0 and 2

| Reference | Characteristics | Min. | Max. | Unit |
|-----------|--|-------|-------|------|
| 1 | Time from master assert SPI_CSN to first clock edge | 45 | – | ns |
| 2 | Hold time for MOSI data lines | 12 | ½ SCK | ns |
| 3 | Time from last sample on MOSI/MISO to slave deassert SPI_INT | 0 | 100 | ns |
| 4 | Time from slave deassert SPI_INT to master deassert SPI_CSN | 0 | – | ns |
| 5 | Idle time between subsequent SPI transactions | 1 SCK | – | ns |

Figure 9. SPI Timing, Mode 0 and 2

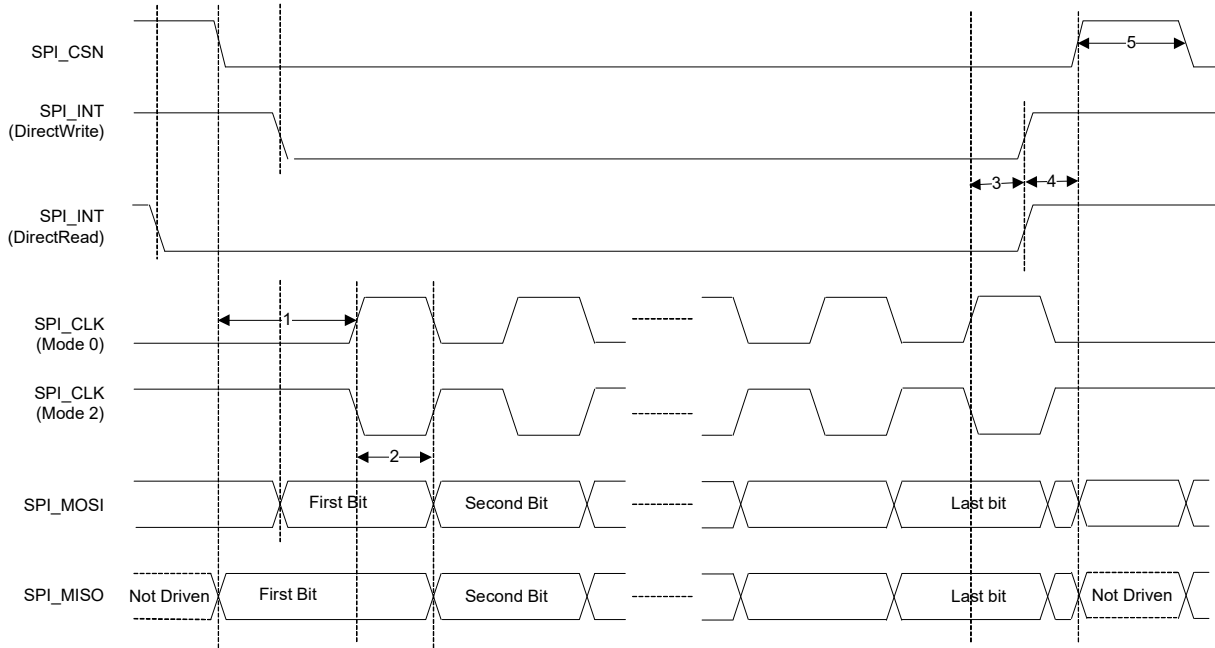
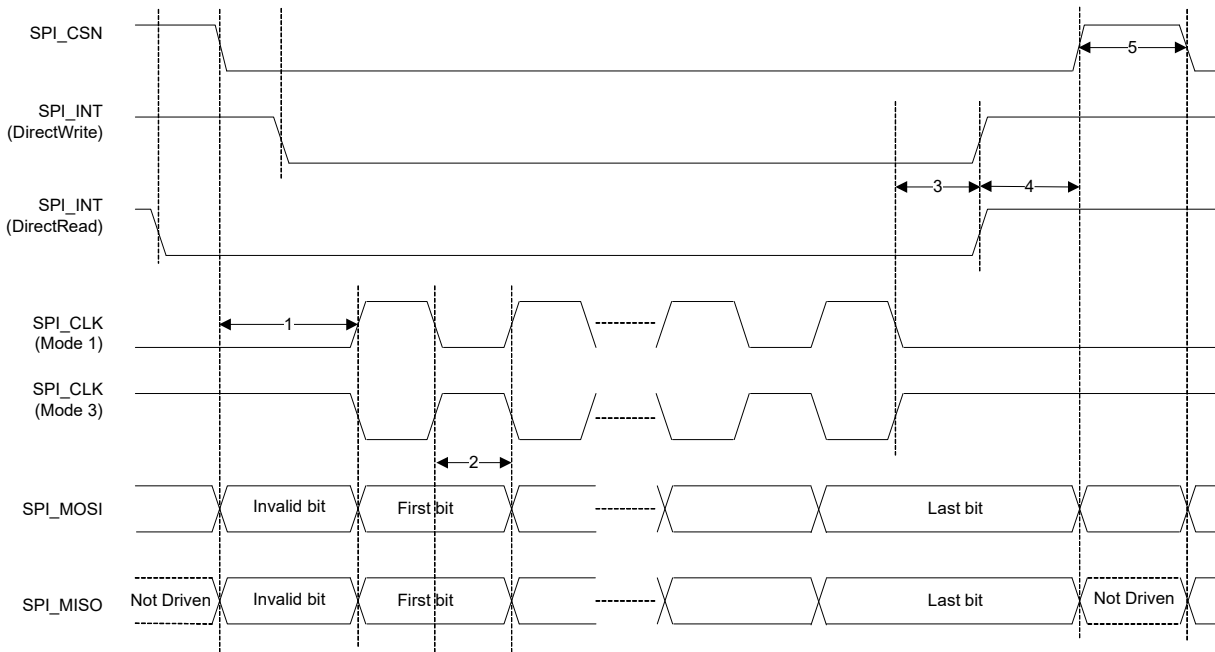

Table 27 and Figure 10 show the timing requirements when operating in SPI Mode 0 and 2.

Table 27. SPI Mode 1 and 3

| Reference | Characteristics | Min. | Max. | Unit |
|-----------|--|-------|-------|------|
| 1 | Time from master assert SPI_CSN to first clock edge | 45 | – | ns |
| 2 | Hold time for MOSI data lines | 12 | ½ SCK | ns |
| 3 | Time from last sample on MOSI/MISO to slave deassert SPI_INT | 0 | 100 | ns |
| 4 | Time from slave deassert SPI_INT to master deassert SPI_CSN | 0 | – | ns |
| 5 | Idle time between subsequent SPI transactions | 1 SCK | – | ns |

Figure 10. SPI Timing, Mode 1 and 3



10.3.3 I²C Compatible Interface Timing

The specifications in Table 28 references Figure 11.

Table 28. I²C Compatible Interface Timing Specifications (up to 1 MHz)

| Reference | Characteristics | Minimum | Maximum | Unit |
|-----------|-----------------------------------|---------|---------|------|
| 1 | Clock frequency | - | 100 | kHz |
| | | | 400 | |
| | | | 800 | |
| | | | 1000 | |
| 2 | START condition setup time | 650 | - | ns |
| 3 | START condition hold time | 280 | - | ns |
| 4 | Clock low time | 650 | - | ns |
| 5 | Clock high time | 280 | - | ns |
| 6 | Data input hold time ^a | 0 | - | ns |
| 7 | Data input setup time | 100 | - | ns |
| 8 | STOP condition setup time | 280 | - | ns |
| 9 | Output valid from clock | - | 400 | ns |
| 10 | Bus free time ^b | 650 | - | ns |

a. As a transmitter, 125 ns of delay is provided to bridge the undefined region of the falling edge of SCL to avoid unintended generation of START or STOP conditions.
 b. Time that the CBUS must be free before a new transaction can start.

Figure 11. I²C Interface Timing Diagram

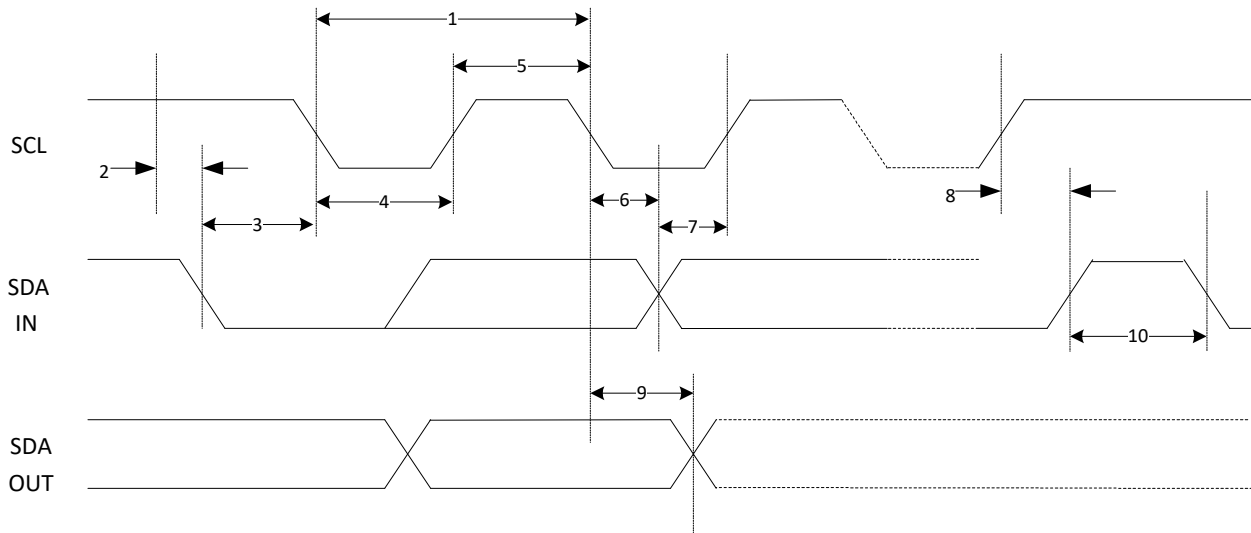
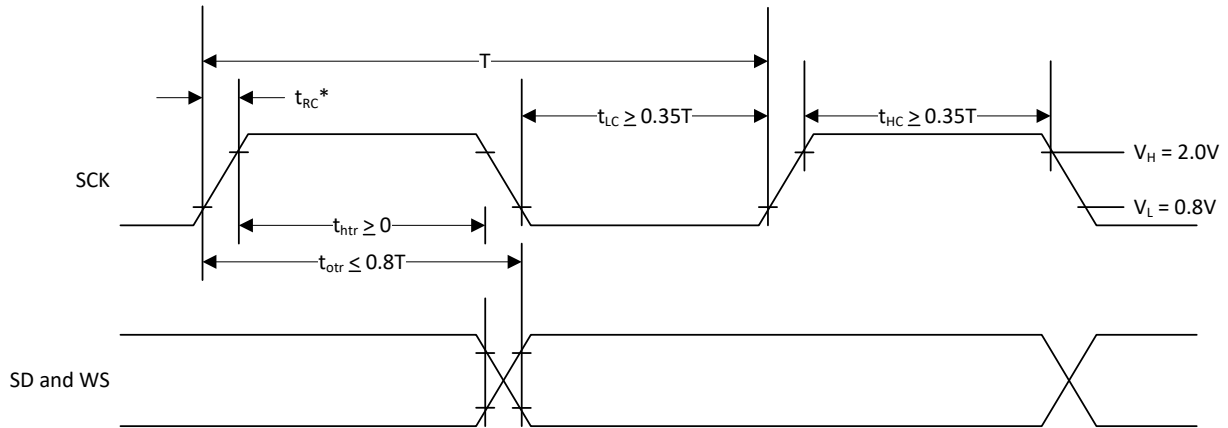

Table 29. Timing for I²S Transmitters and Receivers

| | Transmitter | | | | Receiver | | | | Notes |
|--|--------------|--------------|--------------|--------|--------------|--------------|-------------|-----|-------|
| | Lower Limit | | Upper Limit | | Lower Limit | | Upper Limit | | |
| | Min | Max | Min | Max | Min | Max | Min | Max | |
| Clock Period T | T_{tr} | – | – | – | T_r | – | – | – | a |
| Master Mode: Clock generated by transmitter or receiver | | | | | | | | | |
| HIGH t_{HC} | $0.35T_{tr}$ | – | – | – | $0.35T_{tr}$ | – | – | – | b |
| LOW t_{LC} | $0.35T_{tr}$ | – | – | – | $0.35T_{tr}$ | – | – | – | b |
| Slave Mode: Clock accepted by transmitter or receiver | | | | | | | | | |
| HIGH t_{HC} | – | $0.35T_{tr}$ | – | – | – | $0.35T_{tr}$ | – | – | c |
| LOW t_{LC} | – | $0.35T_{tr}$ | – | – | – | $0.35T_{tr}$ | – | – | c |
| Rise time t_{RC} | – | – | $0.15T_{tr}$ | – | – | – | – | – | d |
| Transmitter | | | | | | | | | |
| Delay t_{dtr} | – | – | – | $0.8T$ | – | – | – | – | e |
| Hold time t_{htr} | 0 | – | – | – | – | – | – | – | d |
| Receiver | | | | | | | | | |
| Setup time t_{sr} | – | – | – | – | $0.2T_{tr}$ | – | – | – | f |
| Hold time t_{hr} | – | – | – | – | $0.2T_{tr}$ | – | – | – | f |

- a. The system clock period T must be greater than T_{tr} and T_r because both the transmitter and receiver have to be able to handle the data transfer rate.
- b. At all data rates in master mode, the transmitter or receiver generates a clock signal with a fixed mark/space ratio. For this reason, t_{HC} and t_{LC} are specified with respect to T.
- c. In slave mode, the transmitter and receiver need a clock signal with minimum HIGH and LOW periods so that they can detect the signal. So long as the minimum periods are greater than $0.35T_{tr}$, any clock that meets the requirements can be used.
- d. Because the delay (t_{dtr}) and the maximum transmitter speed (defined by T_{tr}) are related, a fast transmitter driven by a slow clock edge can result in t_{dtr} not exceeding t_{RC} which means t_{htr} becomes zero or negative. Therefore, the transmitter has to guarantee that t_{htr} is greater than or equal to zero, so long as the clock rise-time t_{RC} is not more than t_{RCmax} , where t_{RCmax} is not less than $0.15T_{tr}$.
- e. To allow data to be clocked out on a falling edge, the delay is specified with respect to the rising edge of the clock signal and T, always giving the receiver sufficient setup time.
- f. The data setup and hold time must not be less than the specified receiver setup and hold time.

Figure 12. I²S Transmitter Timing



T = Clock period
 T_{tr} = Minimum allowed clock period for transmitter
 $T = T_{tr}$
 * t_{RC} is only relevant for transmitters in slave mode.

Figure 13. I²S Receiver Timing

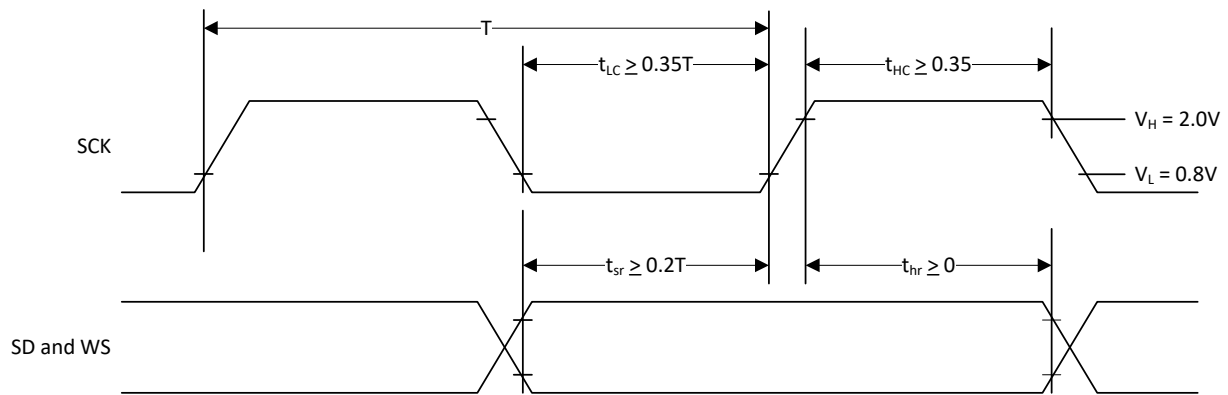

T = Clock period
 T_r = Minimum allowed clock period for transmitter
 $T > T_r$

11. Mechanical Information

11.1 40-Pin QFN Package

Figure 14. CYW20719 5.0 mm x 5.0 mm 40-Pin QFN Package

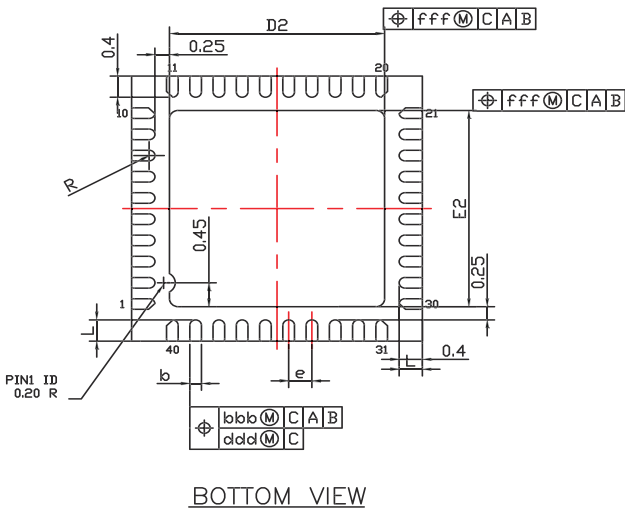
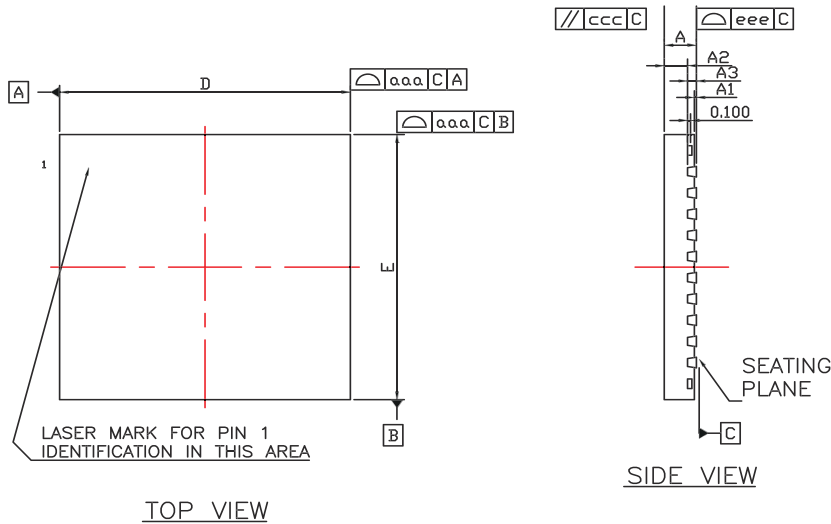

* CONTROLLING DIMENSION : MM

| SYMBOL | MILLIMETER | | |
|--------|------------|-------|-------|
| | MIN. | NOM. | MAX. |
| A | 0.500 | 0.550 | 0.600 |
| A1 | - | - | 0.050 |
| A2 | - | 0.400 | 0.425 |
| A3 | - | 0.152 | REF |
| b | 0.150 | 0.200 | 0.250 |
| D | 5.00 BSC | | |
| D2 | 3.600 | 3.700 | 3.800 |
| E | 5.00 BSC | | |
| E2 | 3.600 | 3.700 | 3.800 |
| L | 0.300 | 0.400 | 0.500 |
| e | 0.400 BSC | | |
| R | 0.075 | - | - |
| aaa | 0.100 | | |
| bbb | 0.070 | | |
| ccc | 0.100 | | |
| ddd | 0.050 | | |
| eee | 0.080 | | |
| fff | 0.100 | | |

1. ALL DIMENSIONS ARE IN MILLIMETERS.
2. DIE THICKNESS ALLOWABLE IS 0.305 mm MAXIMUM (.012 INCHES MAXIMUM)
3. DIMENSIONING & TOLERANCES CONFORM TO ASME Y14.5M. -1994.
4. THE PIN #1 IDENTIFIER MUST BE PLACED ON THE TOP SURFACE OF THE PACKAGE BY USING INDENTATION MARK OR OTHER FEATURE OF PACKAGE BODY.
5. EXACT SHAPE AND SIZE OF THIS FEATURE IS OPTIONAL.
6. PACKAGE WARPAGE MAX 0.08 mm.
7. APPLIED FOR EXPOSED PAD AND TERMINALS. EXCLUDE EMBEDDING PART OF EXPOSED PAD FROM MEASURING.
8. APPLIED ONLY TO TERMINALS.

11.2 WLCSP Package

Figure 15. CYW20719 WLCSP Package

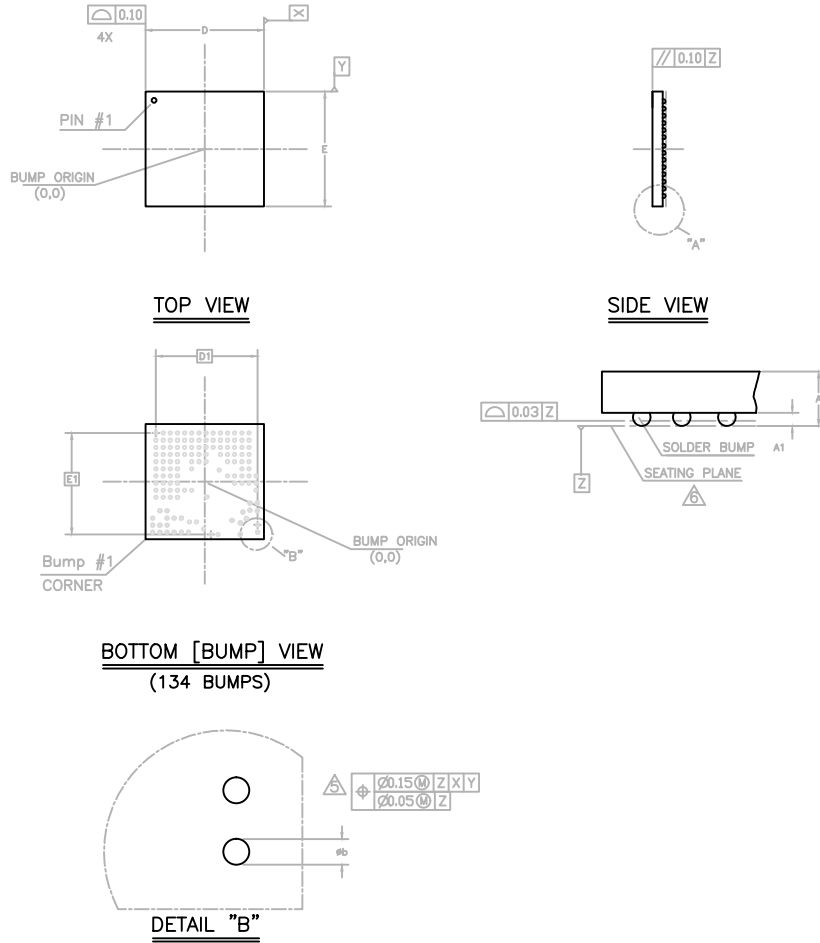

| SYMBOL | DIMENSIONS | | |
|--------|------------|-------|-------|
| | MIN. | NOM. | MAX. |
| A | - | - | 0.33 |
| A1 | 0.075 | 0.090 | 0.105 |
| D | 3.270 | 3.310 | 3.350 |
| E | 3.180 | 3.220 | 3.260 |
| D1 | 2.84 BSC | | |
| E1 | 2.83 BSC | | |
| N | 134 | | |
| ∅ b | 0.100 | 0.115 | 0.130 |

NOTES:

- ALL DIMENSIONS AND TOLERANCES CONFORM TO ASME Y14.5M-1994. NOTES: UNLESS OTHERWISE SPECIFIED
 - BUMP POSITION DESIGNATION PER JESD 95-1, SPP-010
 - REFER TO CYPRESS APPLICATION NOTE "WAFER-SCALE CHIP-SIZED PACKAGE (WSCSP) OVERVIEW AND ASSEMBLY GUIDELINES FOR DESIGN, IMPLEMENTATION, AND MANUFACTURING RECOMMENDATIONS AND GUIDELINES.
 - MINIMUM BUMP PITCH IS 0.200MM
- DIMENSION IS MEASURED AT THE MAXIMUM SOLDER BALL DIAMETER, PARALLEL TO PRIMARY DATUM Z.
- PRIMARY DATUM Z AND SEATING PLANE ARE DEFINED BY THE SPHERICAL CROWNS OF THE SOLDER BALLS.

11.3 WLCSP Package Keep-out

Figure 16. CYW20719YB1 WLCSP Keep-out Model

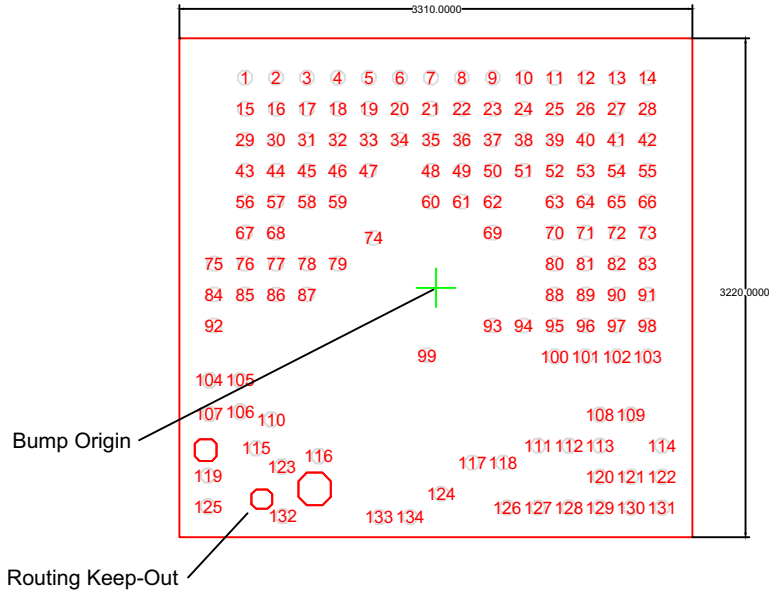

Note: Figure 16 shows the top view of the WLCSP package (Bumps facing down).

11.4 Tape Reel and Packaging Specifications

Table 30. CYW20719 Tape Reel Specifications

| Parameter | Value |
|-------------------|-----------|
| Quantity per reel | 5000 |
| Reel diameter | 13 inches |
| Hub diameter | 4 inches |
| Tape width | 12 mm |
| Tape pitch | 8 mm |

The top-left corner of the CYW20719 package is situated near the sprocket holes, as shown in Figure 17.

Figure 17. Pin 1 Orientation

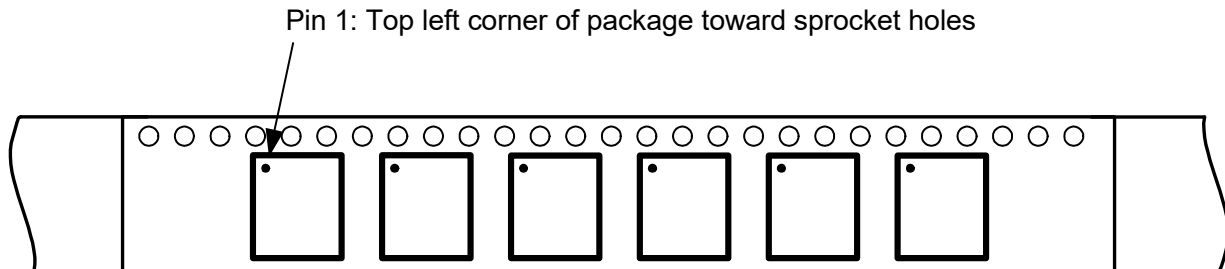

12. Ordering Information

Table 31. Ordering Information

| Part Number | Package | Ambient Operating Temperature |
|-----------------|--------------------------|-------------------------------|
| CYW20719B1KWB9G | 3.2 x 3.1 134-Ball WLCSP | -30°C to 85°C |
| CYW20719B1KUMLG | 5x5 40-pin QFN | -30°C to 85°C |

13. Additional Information

13.1 Acronyms and Abbreviations

The following list of acronyms and abbreviations may appear in this document.

| Term | Description |
|-------|--|
| AFH | adaptive frequency hopping |
| ATT | Attribute Protocol |
| BBC | Bluetooth Baseband Core |
| BDR | basic data rate |
| BLE | Bluetooth low energy |
| BR | basic data rate |
| BQS | Bluetooth Qualification Body |
| CRC | cyclic redundancy check |
| ED | erroneous data |
| EIR | extended inquiry response |
| EPR | encryption pause resume |
| FEC | forward error correction |
| FPU | floating point unit |
| GATT | Generic Attribute Profile |
| GAP | generic access profile |
| GFSK | Gaussian Frequency Shift Keying |
| GPIO | general-purpose I/O |
| HCI | host control interface |
| IF | intermediate frequency |
| JTAG | Joint Test Action Group |
| L2CAP | Logical Link Control and Adaptation Protocol |
| LCU | link control unit |
| LDO | low drop-out |
| LE | low energy |
| LM | Link Manager |
| LO | local oscillator |
| LPO | low power oscillator |
| LSTO | link supervision time out |
| PA | power amplifier |

| Term | Description |
|---------------|--|
| PBF | packet boundary flag |
| PDM | pulse density modulation |
| PDS | Power down sleep |
| PLL | phase locked loop |
| PMU | power management unit |
| POR | power-on reset |
| PRBS | Pseudo Random Binary Sequence |
| PWM | pulse width modulation |
| QFN | quad flat no-lead |
| QoS | quality of service |
| RAM | random access memory |
| RC oscillator | A resistor-capacitor oscillator is a circuit composed of an amplifier, which provides the output signal, and a resistor-capacitor network, which controls the frequency of the signal. |
| RF | radio frequency |
| ROM | read-only memory |
| RX/TX | receive/transmit |
| SCO | synchronous connection-oriented |
| SDP | Service Discovery Protocol |
| SDS | Shut Down Sleep |
| SPI | serial peripheral interface |
| SPIFFY | serial peripheral interface fully functional |
| SSP | secure simple pairing |
| SSR | sniff subrating |
| SWD | serial wire debug |
| TSSI | transmit signal strength indicator |
| UART | universal asynchronous receiver/transmitter |
| WLCSP | wafer level chip scale package |

Document History Page

| Document Title: CYW20719 Enhanced Low Power, BR/EDR/BLE Bluetooth 5.0 SOC | | | | |
|---|---------|-----------------|-----------------|---|
| Document Number: 002-14815 | | | | |
| Revision | ECN | Orig. of Change | Submission Date | Description of Change |
| ** | – | UTSV | 05/03/2016 | 20719-DS100-R Initial release |
| *A | 5441953 | UTSV | 10/05/2016 | Updated to Cypress template Added Cypress part numbering scheme |
| *B | 5889849 | MILI | 09/28/2017 | <p>Added 134-Ball WLCSP in “Features” on page 2.</p> <p>Added VBAT* in the Figure 2 on page 7.</p> <p>Added “The Bypass LDO is activated when the VBAT input voltage falls below 2.1V” in the Section “Power Management Unit” on page 8.</p> <p>Removed Figure 3. Power Management Unit.</p> <p>Updated the title and Figure 4 from Usage Mode 1: RF Powered from LDO (Default) to “Default usage Mode” on page 8.</p> <p>Removed ZA_STRAP, and ZINC_air_strap from Figure 2 on page 8.</p> <p>Removed 1.4.2. Usage Mode 2 and 1.4.3. Usage Mode 3.</p> <p>Changed the title “1.6.1 Cypress Serial Communication Interface” to “I2C Compatible Master” on page 10.</p> <p>Replaced BSC to I²C in the datasheet.</p> <p>Removed second para from the section “UART Interface” on page 10 and added “The Firmware’s UART driver allows applications to select different baud rates”.</p> <p>Removed “Table: Common Baud Rate Examples” and the corresponding sentences from the section “UART Interface” on page 10.</p> <p>Updated Figure 2: Replaced 22pF with CL1 and 20pF with CL2.</p> <p>Updated Table 3 on page 11.</p> <p>Removed 1.9.2 HID Peripheral Block</p> <p>Added “Those pins include PWM functionality which can be used for LED dimming” in the section GPIO Ports on page 12 and also the “Note: On the double and triple bonded pins, only one of the GPIO can be used at a given time. When a certain GPIO is selected, the other GPIOs bonded to the same pin must be configured to input and output disable”.</p> <p>Replaced “PAVDD2P5” to “PAVDD” throughout the document.</p> <p>Added “The 20719 includes one double-axis and one single axis quadrature decoders. There are two input lines for each axis and a programmable control signal that can be active high or low.</p> <p>The application can access the quadrature interface via the driver included in the firmware.” in the Mouse Quadrature Signal Decoder on page 13.</p> <p>Removed 1.17 Infrared Modulator and 1.18 Infrared Learning.</p> <p>Added Table 7 on page 25 and Table 8 on page 28.</p> <p>Updated the title to “Enhanced Low Power Bluetooth 5.0/BLE/2 Mbps LE/EDR/Integrated SOC”.</p> <p>Updated Table 12 on page 33 and Table 13 on page 34.</p> <p>Removed Table: Cypress Part Numbering Scheme from Page 1.</p> |

Document History Page

| Document Title: CYW20719 Enhanced Low Power, BR/EDR/BLE Bluetooth 5.0 SOC | | | | |
|---|---------|-----------------|-----------------|--|
| Document Number: 002-14815 | | | | |
| Revision | ECN | Orig. of Change | Submission Date | Description of Change |
| *C | 6075109 | SGUP | 03/09/2018 | <p>Updated Figure 1 and Figure 2. Added Features and Applications section. Created a table for Bluetooth Features. Updated with "The CYW20719 includes a Cortex M4 processor with 2 Mbyte of program ROM, 448 KB of data RAM, 64 KB of patch RAM, and 1 Mbyte of on-chip flash. The M4 has a maximum speed of 96 MHz. The 1 Mbyte of flash is supported by an 8KB cache allowing direct code execution from flash at near maximum speed and low power consumption. The CM4 also includes a single precision IEEE 754 compliant floating point unit (FPU).The CM4 runs all the BT layers as well as application code. The ROM includes LM, HCI, L2CAP, GATT, as well as other stack layers freeing up the flash for application usage. A standard serial wire debug (SWD) interface provides debugging support." in MCU. Changed the title I2C to I2C Compatible Master and UART Interface to HCI UART Interface. Updated Table 2, Table 4, Table 9, Table 12, Table 14, Table 17, Table 16, Table 17, Table 20, Table 21 and Table 22. Updated GPIO Ports, ADC, PWM, Serial Peripheral Interface block. Created Table 6 and Table 7. Added the terms BQS, PRBS and SPIFFY to Acronyms and Abbreviations table. Removed all references of "LHL". Added Table 18 in the ADC Electrical Characteristics section. Replaced "CSC" as "I2C" throughout the document. Table 20 and Table 22: Updated footnote "Up to 1dB of variation is expected from typical sensitivity specs due to the chip and board variation". Added ADC Electrical Characteristics. Added Random Number Generator section. Updated Power Modes section. Table 5: Removed the description "Quadrature, Peripheral UART, SPI_1, I2C, Keyboard Scan output and External T/R switch control". Removed Figure: Reset Timing. Added "I2C1 is Master Only; I2C2 is Master/Slave. The Slave support is subject to driver support in WICED Studio" to I2C Compatible Master section. Added "P15 is Bonded to the same pin as XTALI_32K on the QFN package (Pin 32). If External 32.768KHz crystal is not used, then this pin can be used as GPIO P15" to GPIO Ports section. Table 3: Added "External AC Input Amplitude" Parameter. Removed tables: Digital LDO and RF LDO. Table 17: Added UART_TXD VOL and UART_TXD VOH characteristics. Table 18: Removed "Analog supply Voltage", "Analog core supply" and "Audio supply" Parameters.</p> |

Document History Page

| Document Title: CYW20719 Enhanced Low Power, BR/EDR/BLE Bluetooth 5.0 SOC | | | | |
|---|---------|-----------------|-----------------|--|
| Document Number: 002-14815 | | | | |
| Revision | ECN | Orig. of Change | Submission Date | Description of Change |
| *D | 6222848 | MILI | 07/12/2018 | <p>Table 4: Updated QFN-40 value as 26 for the Reserved Pin and removed the QFN value for BT_VDDO and added a row for “Reserved, Connect to GND”.</p> <p>Table 8: Updated “VSSO_0” to “Reserved, Connect to GND” and added a row for “ BT_VSSC”.</p> <p>Figure 6: Changed BT_VDDC to RSVD.</p> <p>Updated Table 7, Table 14 and Table 18.</p> <p>Added a Table 23.BLE2M RF Specifications on page 35.</p> <p>Figure 1: Removed “Programmable wait states”.</p> <p>Table 11: Added note “Lowest operating temperature for the 32 KHz xtal is -10°C.</p> <p>Updated I2S Interface and PCM Interface sections.</p> <p>Updated Acronyms and Abbreviations section.</p> |

Sales, Solutions, and Legal Information

Worldwide Sales and Design Support

Cypress maintains a worldwide network of offices, solution centers, manufacturer's representatives, and distributors. To find the office closest to you, visit us at [Cypress Locations](#).

Products

| | |
|-------------------------------|--|
| Arm® Cortex® Microcontrollers | cypress.com/arm |
| Automotive | cypress.com/automotive |
| Clocks & Buffers | cypress.com/clocks |
| Interface | cypress.com/interface |
| Internet of Things | cypress.com/iot |
| Memory | cypress.com/memory |
| Microcontrollers | cypress.com/mcu |
| PSoC | cypress.com/psoc |
| Power Management ICs | cypress.com/pmic |
| Touch Sensing | cypress.com/touch |
| USB Controllers | cypress.com/usb |
| Wireless Connectivity | cypress.com/wireless |

PSoC® Solutions

[PSoC 1](#) | [PSoC 3](#) | [PSoC 4](#) | [PSoC 5LP](#) | [PSoC 6 MCU](#)

Cypress Developer Community

[Community](#) | [Projects](#) | [Video](#) | [Blogs](#) | [Training](#) | [Components](#)

Technical Support

cypress.com/support

© Cypress Semiconductor Corporation, 2016-2018. This document is the property of Cypress Semiconductor Corporation and its subsidiaries, including Spansion LLC ("Cypress"). This document, including any software or firmware included or referenced in this document ("Software"), is owned by Cypress under the intellectual property laws and treaties of the United States and other countries worldwide. Cypress reserves all rights under such laws and treaties and does not, except as specifically stated in this paragraph, grant any license under its patents, copyrights, trademarks, or other intellectual property rights. If the Software is not accompanied by a license agreement and you do not otherwise have a written agreement with Cypress governing the use of the Software, then Cypress hereby grants you a personal, non-exclusive, nontransferable license (without the right to sublicense) (1) under its copyright rights in the Software (a) for Software provided in source code form, to modify and reproduce the Software solely for use with Cypress hardware products, only internally within your organization, and (b) to distribute the Software in binary code form externally to end users (either directly or indirectly through resellers and distributors), solely for use on Cypress hardware product units, and (2) under those claims of Cypress's patents that are infringed by the Software (as provided by Cypress, unmodified) to make, use, distribute, and import the Software solely for use with Cypress hardware products. Any other use, reproduction, modification, translation, or compilation of the Software is prohibited.

TO THE EXTENT PERMITTED BY APPLICABLE LAW, CYPRESS MAKES NO WARRANTY OF ANY KIND, EXPRESS OR IMPLIED, WITH REGARD TO THIS DOCUMENT OR ANY SOFTWARE OR ACCOMPANYING HARDWARE, INCLUDING, BUT NOT LIMITED TO, THE IMPLIED WARRANTIES OF MERCHANTABILITY AND FITNESS FOR A PARTICULAR PURPOSE. No computing device can be absolutely secure. Therefore, despite security measures implemented in Cypress hardware or software products, Cypress does not assume any liability arising out of any security breach, such as unauthorized access to or use of a Cypress product. In addition, the products described in these materials may contain design defects or errors known as errata which may cause the product to deviate from published specifications. To the extent permitted by applicable law, Cypress reserves the right to make changes to this document without further notice. Cypress does not assume any liability arising out of the application or use of any product or circuit described in this document. Any information provided in this document, including any sample design information or programming code, is provided only for reference purposes. It is the responsibility of the user of this document to properly design, program, and test the functionality and safety of any application made of this information and any resulting product. Cypress products are not designed, intended, or authorized for use as critical components in systems designed or intended for the operation of weapons, weapons systems, nuclear installations, life-support devices or systems, other medical devices or systems (including resuscitation equipment and surgical implants), pollution control or hazardous substances management, or other uses where the failure of the device or system could cause personal injury, death, or property damage ("Unintended Uses"). A critical component is any component of a device or system whose failure to perform can be reasonably expected to cause the failure of the device or system, or to affect its safety or effectiveness. Cypress is not liable, in whole or in part, and you shall and hereby do release Cypress from any claim, damage, or other liability arising from or related to all Unintended Uses of Cypress products. You shall indemnify and hold Cypress harmless from and against all claims, costs, damages, and other liabilities, including claims for personal injury or death, arising from or related to any Unintended Uses of Cypress product.

Cypress, the Cypress logo, Spansion, the Spansion logo, and combinations thereof, WICED, PSoC, CapSense, EZ-USB, F-RAM, and Traveo are trademarks or registered trademarks of Cypress in the United States and other countries. For a more complete list of Cypress trademarks, visit cypress.com. Other names and brands may be claimed as property of their respective owners.

Компания «Океан Электроники» предлагает заключение долгосрочных отношений при поставках импортных электронных компонентов на взаимовыгодных условиях!

Наши преимущества:

- Поставка оригинальных импортных электронных компонентов напрямую с производств Америки, Европы и Азии, а так же с крупнейших складов мира;
- Широкая линейка поставок активных и пассивных импортных электронных компонентов (более 30 млн. наименований);
- Поставка сложных, дефицитных, либо снятых с производства позиций;
- Оперативные сроки поставки под заказ (от 5 рабочих дней);
- Экспресс доставка в любую точку России;
- Помощь Конструкторского Отдела и консультации квалифицированных инженеров;
- Техническая поддержка проекта, помощь в подборе аналогов, поставка прототипов;
- Поставка электронных компонентов под контролем ВП;
- Система менеджмента качества сертифицирована по Международному стандарту ISO 9001;
- При необходимости вся продукция военного и аэрокосмического назначения проходит испытания и сертификацию в лаборатории (по согласованию с заказчиком);
- Поставка специализированных компонентов военного и аэрокосмического уровня качества (Xilinx, Altera, Analog Devices, Intersil, Interpoint, Microsemi, Actel, Aeroflex, Peregrine, VPT, Syfer, Eurofarad, Texas Instruments, MS Kennedy, Miteq, Cobham, E2V, MA-COM, Hittite, Mini-Circuits, General Dynamics и др.);

Компания «Океан Электроники» является официальным дистрибьютором и эксклюзивным представителем в России одного из крупнейших производителей разъемов военного и аэрокосмического назначения «JONHON», а так же официальным дистрибьютором и эксклюзивным представителем в России производителя высокотехнологичных и надежных решений для передачи СВЧ сигналов «FORSTAR».



JONHON

«JONHON» (основан в 1970 г.)

Разъемы специального, военного и аэрокосмического назначения:

(Применяются в военной, авиационной, аэрокосмической, морской, железнодорожной, горно- и нефтедобывающей отраслях промышленности)

«FORSTAR» (основан в 1998 г.)

ВЧ соединители, коаксиальные кабели,
кабельные сборки и микроволновые компоненты:

(Применяются в телекоммуникациях гражданского и специального назначения, в средствах связи, РЛС, а так же военной, авиационной и аэрокосмической отраслях промышленности).



Телефон: 8 (812) 309-75-97 (многоканальный)

Факс: 8 (812) 320-03-32

Электронная почта: ocean@oceanchips.ru

Web: <http://oceanchips.ru/>

Адрес: 198099, г. Санкт-Петербург, ул. Калинина, д. 2, корп. 4, лит. А