

# PRODUCT CATALOG

## RF & Microwave Connectors & Cable Assemblies



  
**EMERSON**  
Network Power

**Johnson**  
Connectivity Solutions

Emerson Network Power Connectivity Solutions has a wide range of cable assemblies and connectors suited for RF, Microwave and Fiber Optic signal transmission. Connectivity Solutions is a vertically integrated supplier of custom, fixed length and semi-rigid cable assemblies from DC to 50 GHz. Our product lines deliver custom-engineered products and solutions to satisfy the most demanding and complex requirements.

**AIM-Cambridge**  
Connectivity Solutions



AIM-Cambridge has a universal line of products that offer cost effective, high quality solutions for connectivity. Our connectors are available in BNC, Type N, F Type, RCA, UHF, Mini-UHF, TNC, D-Sub and Modular Plugs for Data/Telecom applications. In addition, we stock a wide variety of cables for A/V, SATV, CATV, computer and LAN applications, as well as a complete line of termination tools and structured cabling products. AIM-Cambridge promises that its product will provide you with unmatched consistency, quality, reliability and ease of use.

**Johnson**  
Connectivity Solutions



Johnson designs and manufactures an industry leading line of RF coaxial connectors and adapters, which are available in both 50 and 75 ohm versions. Johnson connectors are designed to provide the highest quality data transmission for audio, video and data applications. The Johnson line of products can address frequency ranges from DC to 46GHz and all sizes from Ultra-miniature interfaces (UMC), Micro-miniature, (MCX, MMCX, SMP), Subminiature (SMA, SMB, SMK, kwiQMAte™), Medium connectors (Type N connectors) through to large connectors (DIN7/16). The breadth of products available within the Johnson range includes board and cable mount connectors as well as semi-rigid, conformable, and flexible RF coaxial cables.

**Midwest Microwave**  
Connectivity Solutions



Midwest Microwave manufactures passive coaxial microwave components that are known for their precision performance and high quality that meets the precise requirements of the RF/Microwave industry. Our broad product portfolio includes: Attenuators, Precision Adapters, Terminations, DC Blocks, Power Dividers, Couplers, Equalizers, Phase Shifters, Connectors, Custom Cable Assemblies and Test Cables that are designed and manufactured for both military and commercial applications.

Midwest also offers a wide variety of Qualified Product List (QPL) approved products in the M3933, M39030 and M39012 series, as well as many DESC/DSCC approved models.

**Semflex**  
Connectivity Solutions



Semflex designs and manufactures low loss, flexible, microwave coaxial cable and custom cable assemblies for the military/aerospace, commercial OEM and test instrumentation markets. Semflex offers cables ranging from DC to 50 GHz, available with ultra low insertion loss, power ratings up to 21 KW, and available with all popular connectors.

**Stratos**  
Connectivity Solutions



Stratos optical connectivity products is globally recognized as highly reliable, cost-effective, and provides optical connectivity solutions that are virtually immune to dust, mud, oil, water, and other contaminants.

Our expanded beam connectivity products are ideal for harsh environment applications in the broadcast, industrial, petrochemical and military/aerospace markets where high reliability, low maintenance and quick serviceability are critical requirements. Our optical active products are used mainly in military, aerospace and industrial markets where high speed/high reliable performance is mission critical. The actives product line includes optical transceivers, optical media converters and custom devices tailored to your application.

**Trompeter**  
Connectivity Solutions



Trompeter is recognized as a global leader in delivering best in class RF connectivity products. The Trompeter line of patch jacks, RF connectors, cable assemblies, HDTV digital technology and DS3 connectivity solutions is unrivalled. Our mission is to provide products that continually deliver the highest quality signal integrity for the most demanding applications in Telecom, Central Office, Broadcast, Military Aerospace, and Instrumentation markets worldwide. Our extensive line of cost-effective products are rigorously designed and tested to provide the critically engineered solutions necessary to enhance the end-user's overall experience.

**Vitelec**  
Connectivity Solutions



Vitelec provides a comprehensive range of RF coaxial interconnect products and cable assemblies. The company has a long established reputation for offering quality and innovation with a wide range of both standard and custom designed products for the electronic and communication industries.

**MMCX Connectors**

50 Ohm Connectors  
 Specifications..... 4  
 Semi-Rigid and Flexible Cable ..... 6  
 PC Mount ..... 8  
 Termination ..... 9

Non-Magnetic Connectors - 50 Ohm  
 Specifications..... 11  
 Semi-Rigid and Flexible Cable ..... 12  
 PC Mount ..... 12

Other Information  
 Assembly Tools ..... 185  
 Cable Information ..... 192  
 Assembly Instructions..... 193  
 Mounting Hole Layouts ..... 194  
 Index..... 274  
 Competitor Cross Reference ..... 280

**3** **MMCX Connectors**

**13** **MCX Connectors**

**39** **SMK Connectors**

**45** **SMA Connectors**

**103** **SMB Connectors**

**131** **SMC Connectors**

**137** **SMP Connectors**

**145** **Type N Connectors**

**153** **Shielded Cable Terminations**

**157** **Between-Series Adapters**

**161** **Fixed Length Cable Assemblies**

**173** **Ultra Miniature Connectors (UMC)**

**181** **kwiQMAte™ Connectors**

**185** **Tools**

**193** **Assembly Instructions**

**257** **Electronic Hardware**

**274** **Index**

*While every precaution has been taken to ensure accuracy and completeness herein, Emerson Network Power Connectivity Solutions assumes no responsibility, and disclaims all liability for damages resulting from use of this information or for any errors or omissions. Specifications subject to change without notice.*

Electrical Specifications

Impedance: 50 Ohms

Frequency Range:

Connectors .....	0-6 GHz
Dummy loads.....	0-1 GHz

VSWR (max): (f = GHz)

	Straight Cable Connectors	Right Angle Cable Connectors
.047 OD .....	1.20	1.14 + .07f
RG-178, RG-316, RG-316 DS .....	1.20	1.25
RG-405 .....	1.15	1.15
Uncabled receptacles, dummy loads .....	N/A	

Working Voltage:

Connectors .....	170 VRMS at sea level†
Dummy loads.....	N/A

Dielectric Withstanding Voltage:

Connectors.....	500 VRMS at sea level†
Dummy loads.....	N/A

Insulation Resistance: 1000 megohms min

Contact Resistance: (milliohms max)

	Initial	After Environmental
Center contact (straight cabled connectors and uncabled receptacles) .....	5.0	8.0
Center contact (right angle cabled connectors).....	5.0	15.0
Outer contact (all connectors).....	1.0	1.5
Braid to body .....	1.5	N/A

Corona Level:

Connectors .....	190 volts min at 70,000 feet†
Dummy loads.....	N/A

Insertion Loss: (dB max, tested at 1 GHz)

Straight cabled connectors .....	0.1
Right angle cabled connectors.....	0.2
Uncabled receptacles, dummy loads.....	N/A

RF Leakage: (dB min, tested at 2.5 GHz)

Flexible cable .....	-60 dB
RG-405 .....	-70 dB
Dummy loads .....	N/A

RF High Potential Withstanding Voltage: (400 VRMS at 4 and 7 MHz)†

Power Rating (Dummy Load): 0.5 watt @ +25°C, derated to 0.25 watt @ +125°C

†Avoid user injury due to misapplication. See safety advisory definitions inside front cover.

Mechanical Specifications

Engagement Design: Series MMCX

Engagement/Disengagement Force: 8 lbs max axial engagement  
1.4 lbs min axial disengagement

Contact Retention: 2.0 lbs min axial force

Cable Retention:

	Axial Force* (lbs)	Torque (oz-in)
.047 flexible .....	3.5	N/A
RG-178 .....	7.0	N/A
RG-316 .....	20.0	N/A
RG-316 DS .....	25.0	N/A
RG-405 .....	30.0	16

\*Or cable breaking strength whichever is less.

Durability: ..... 500 cycles min

Environmental Specifications

(Meets or Exceeds the Applicable Paragraph of MIL-PRF-39012)

Temperature Range:

Connectors .....	- 65°C to + 165°C
Dummy loads .....	- 65°C to + 125°C

Thermal Shock: MIL-STD-202, Method 107, Condition C, except -55°C to +155°C (N/A dummy loads)

Corrosion: MIL-STD-202, Method 101, Condition B (N/A dummy loads)

Shock: MIL-STD-202, Method 213, Condition B (N/A dummy loads)

Vibration: MIL-STD-202, Method 204, Condition D (N/A dummy loads)

Moisture Resistance: MIL-STD-202, Method 106 (N/A dummy loads)

Material Specifications

- Bodies:** Brass per ASTM B16, gold plated\*\* per MIL-DTL-45204 .00001" min
- Contacts:** Beryllium copper per ASTM B196, gold plated per MIL-DTL-45204 .00003" min
- Interface Spring:** Beryllium copper per ASTM B196, gold plated per MIL-DTL-45204 .00003" min
- Insulators:** PTFE fluorocarbon per ASTM D 1710 and ASTM D 1457
- Crimp Sleeves:** Copper per ASTM B301 or brass per ASTM B16, gold plated per MIL-DTL-45204 .00001" min
- Mounting Hardware:** Brass (nuts) per ASTM B16 or phosphor bronze (lockwashers) per ASTM B139, gold plated per MIL-DTL-45204 .00001" min

\*\*All gold plated parts include a .00005" min nickel barrier layer.

Mating Engagement for MMCX Series

- ID of contact to meet VSWR mating characteristics and connector durability when mated with a dia .016 +/- .001 male contact.
- Must meet the force to engage and disengage when mated with mating part.

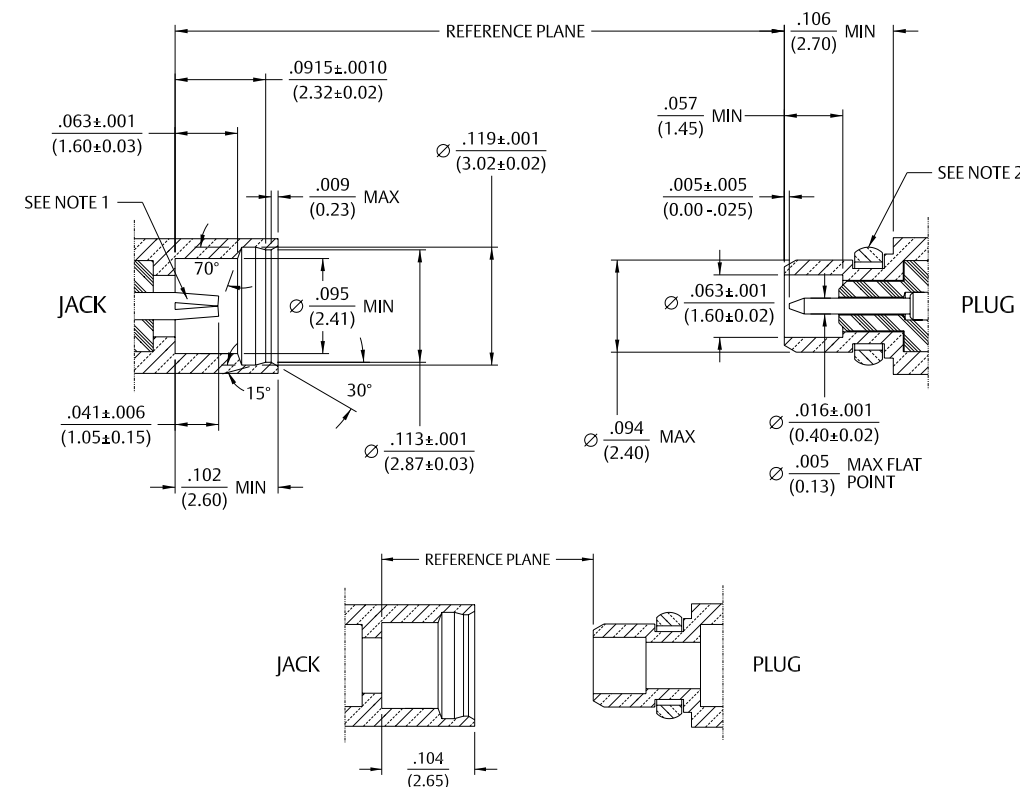

For more information, please contact customer service at (507) 833-8822 or (800) 247-8256 • www.EmersonConnectivity.com

Illustrations are shown in inches (millimeters).

## Semi-Rigid and Flexible Cable

### Right Angle Solder Type Plug – Captivated Contact

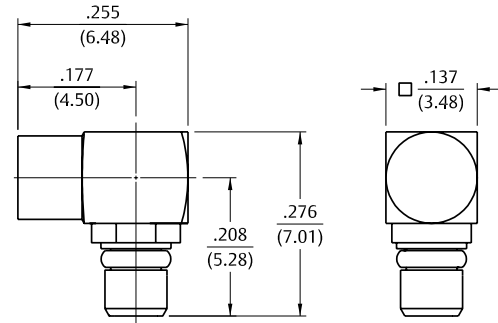

Cable Type	Gold Plated
RG-405	135-3693-101

Assembly instructions page 198.

### Right Angle Crimp Type Plug – Captivated Contact

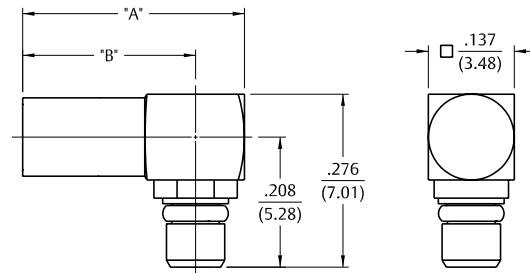

Cable Type	Gold Plated	"A"	"B"	Termination
.047" OD Flexible	135-3436-101	.354 (8.99)	.276 (7.01)	Crimp Insert
RG-178, 196	135-3402-101	.354 (8.99)	.276 (7.01)	Crimp Insert
RG-178, 196	135-3402-111	.412 (10.46)	.334 (8.48)	Crimp Sleeve
RG-316, 188, 161, 174, 179, 187	135-3403-101	.412 (10.46)	.334 (8.48)	Crimp Sleeve
RG-316 DS, 188 DS	135-3404-101	.412 (10.46)	.334 (8.48)	Crimp Sleeve

Assembly instructions page 200 and 201.

## Semi-Rigid and Flexible Cable

### Straight Crimp Type Plug – Solder or Crimp Captivated Contact

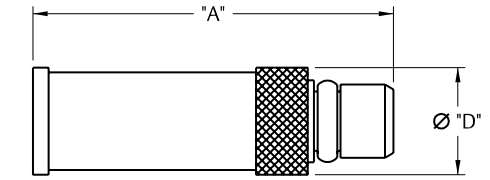

Cable Type	Gold Plated	"A"	"D"	Termination
.047" OD Flexible	135-3436-001	.462 (11.73)	.137 (3.48)	Crimp Insert
RG-178, 196	135-3402-001	.462 (11.73)	.137 (3.48)	Crimp Insert
RG-316, 188, 161, 174	135-3403-001	.509 (12.93)	.173 (4.39)	Crimp Sleeve
RG-316 DS, 188 DS	135-3404-001	.509 (12.93)	.173 (4.39)	Crimp Sleeve
RG-179, 187	135-3433-001	.509 (12.93)	.173 (4.39)	Crimp Sleeve

Assembly instructions page 202 and 203.

### Straight Crimp Type Jack – Solder or Crimp Captivated Contact

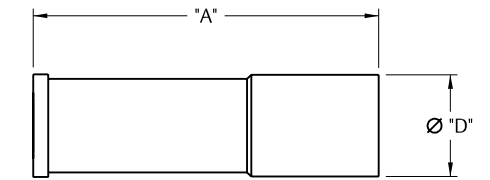

Cable Type	Part No.	"A"	"D"	Termination
.047" OD Flexible	135-3336-001	.462 (11.73)	.137 (3.48)	Crimp Insert
RG-178, 196	135-3302-001	.462 (11.73)	.137 (3.48)	Crimp Insert
RG-316, 188, 161, 174	135-3303-001	.545 (13.84)	.173 (4.39)	Crimp Sleeve
RG-316 DS, 188 DS	135-3304-001	.545 (13.84)	.173 (4.39)	Crimp Sleeve
RG-179, 187	135-3333-001	.545 (13.84))	.173 (4.39)	Crimp Sleeve

Assembly instructions page 204 and 205.

### Straight Crimp Type Bulkhead Jack – Solder or Crimp Captivated Contact

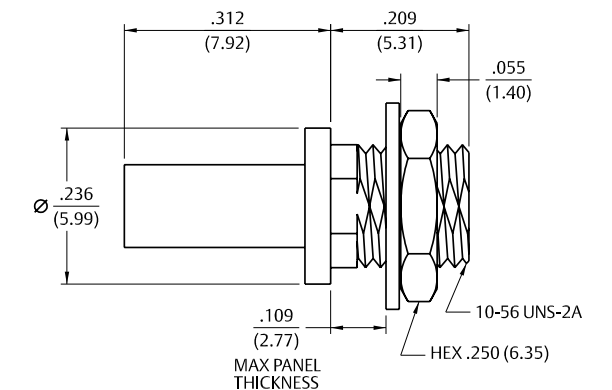

Cable Type	Gold Plated	Termination
.047" OD Flexible	135-3336-401	Crimp Insert
RG-178, 196	135-3302-401	Crimp Insert

Assembly instructions page 205.  
Mounting Hole layout figure 5 page 194.

## PC Mount

### Right Angle Jack Receptacle



Gold Plated	"A"
135-3701-301	.115 (2.92)
135-3701-311	.068 (1.73)

Mounting Hole layout figure 12 page 194.

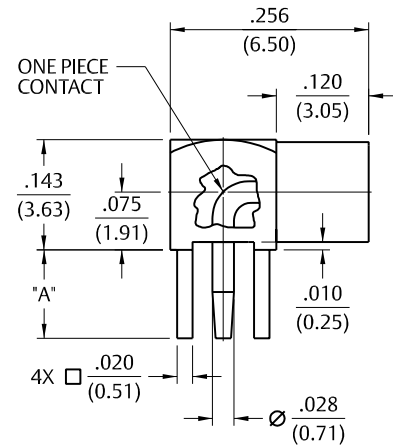

### Straight Jack Receptacle



Gold Plated	"A"
135-3701-201	.115 (2.92)
135-3701-211	.068 (1.73)

Mounting Hole layout figure 12 page 194.

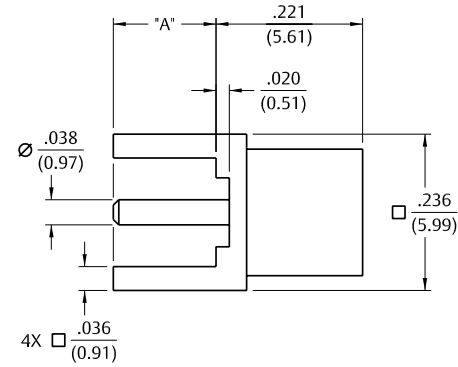

### Straight Surface Mount Jack Receptacle



Gold Plated	Packaging
135-3711-201	Stock
135-3711-202	Tape and Reel, 1500 pcs/reel

Recommended Land Pattern figure 15 page 195.  
Tape and Reel .315 (8.0) component pitch .630 (16.0) wide.

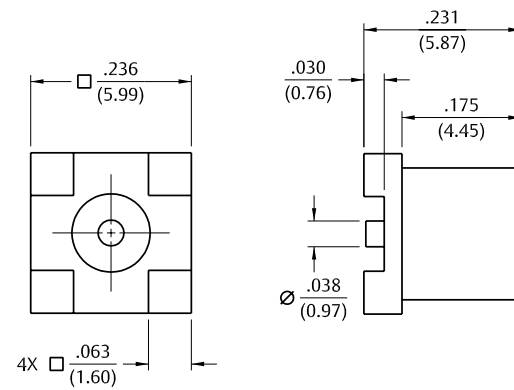

## PC Mount

### Straight Plug Receptacle



Gold Plated
135-3801-201

Mounting Hole layout figure 12 page 194.

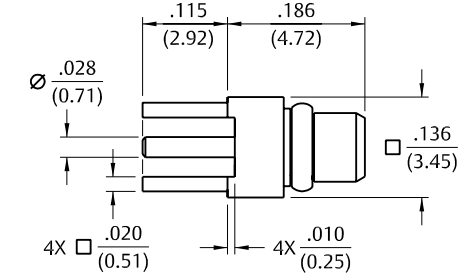

### End Launch Surface Mount Jack Receptacle



Gold Plated	Packaging
135-3711-801	Stock
135-3711-802	Tape and Reel, 1000 pcs/reel

Recommended Land Pattern and Board Notch figure 14 page 195.  
Tape and Reel .316 (8.0) component pitch .630 (16.0) wide.

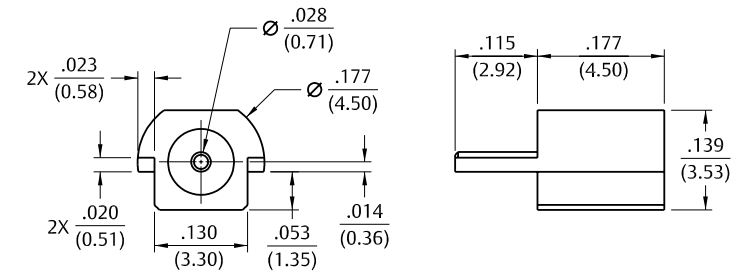

### Plug Dummy Load



Gold Plated	Resistance
135-3801-811	50 Ohms

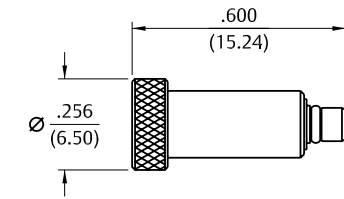

## Non-Magnetic Connectors

Our line of non-magnetic connectors is one of many successful examples of how Johnson® commercializes the high-end, custom application into the cost-sensitive solution that maintains the original Mil-Spec performance. As MRI and other magnetically sensitive technologies grow and evolve so to must the Johnson connector portfolio. Stronger magnetic fields, demands for better signal-to-noise ratios, custom-sized and modular flex coils for increasingly smaller machines: the RF connectors within the equipment have to bear an increasingly tricky role of delivering higher through-put while creating less interference.

With SMA, SMB, MCX, MMCX and soon SMP interfaces made available in a variety of PC and Cable-Mount designs, we can deliver the imaging performance your customers count on.

- The materials and finishes of our connectors meet the stringent limits of image and magnetic field distortion in an MR environment.
- The connector electrical performance exceeds the frequency requirements of the Receive/Transmit RF Coils in MR equipment (typically DC-6 GHz).
- The copper alloys of the body, springs and contact parts are designed to provide uniformity and maintain low permeability and magnetic susceptibility.
- Gold finishes are altered to eliminate magnetic barrier layers and provide excellent corrosion resistance and wear characteristics.
- Plugs maintain their electrical and mechanical performances in the environments of high-vibration common with MRI machines.
- A robust connector assembly design allows for a high count of mating cycles.
- As a helpful visual cue the connectors are marked "NM".



Emerson Connectivity Solutions Non-Magnetic design capabilities expand beyond the parts and interfaces listed in this catalog. Please contact technical support to discuss the options for manufacturing your customized interconnects.

## Electrical Specifications

<b>Impedance:</b> 50 Ohms		
<b>Frequency Range:</b> .....		0-6 GHz
<b>VSWR (max):</b> (max) (f = GHz)		
	Straight Cabled Connectors	Right Angle Cabled Connectors
.047 dia.....	1.20	1.14 + .07f
RG-178, RG-316, RG-316 DS.....	1.20	1.25
<b>Working Voltage:</b>		
Connectors .....		170 VRMS at sea level†
<b>Dielectric Withstanding Voltage:</b>		
Connectors .....		500 VRMS at sea level†
<b>Insulation Resistance:</b> 1000 megohms min		
<b>Contact Resistance:</b> (milliohms max)	<u>Initial</u>	<u>After Environmental</u>
Center contact (straight cabled connectors and uncabled receptacles) .....	5.0	8.0
Center contact (right angle cabled connectors) .....	5.0	15.0
Outer contact (all connectors) .....	1.0	1.5
Braid to body .....	1.5	N/A
<b>Corona Level:</b>		
Connectors .....		190 volts min at 70,000 feet†
<b>Insertion Loss:</b> (dB max, tested at 1 GHz)		
Straight cabled connectors .....		0.1
Right angle cabled connectors.....		0.2
Uncabled receptacles.....		N/A
<b>RF Leakage:</b> (dB min, tested at 2.5 GHz)		
Flexible cable.....		-60 dB
<b>RF High Potential Withstanding Voltage:</b> 400 VRMS min (tested at 4 and 7 MHz)†		

## Mechanical Specifications

<b>Engagement Design:</b> Series MMCX		
<b>Engagement/Disengagement Force:</b> 8 lbs max axial engagement 1.4 lbs min axial disengagement		
<b>Contact Retention:</b> 2.0 lbs min axial force	<u>Axial Force* (lbs)</u>	<u>Torque (oz-in)</u>
<b>Cable Retention:</b>		
.047 flexible .....	3.5	N/A
RG-178.....	7.0	N/A
RG-316.....	20.0	N/A
RG-316 DS.....	25.0	N/A
RG-405.....	30.0	16
*Or cable breaking strength whichever is less.		
<b>Durability:</b> .....		500 cycles min

## Environmental Specifications

(Meets or Exceeds the Applicable Paragraph of MIL-PRF-39012)

<b>Temperature Range:</b> .....	-65°C to +165°C
<b>Thermal Shock:</b> MIL-STD-202, Method 107, Condition C (except -55° C to +155° C)	
<b>Corrosion:</b> MIL-STD-202, Method 101, Condition B	
<b>Shock:</b> MIL-STD-202, Method 213, Condition B	
<b>Vibration:</b> MIL-STD-202, Method 204, Condition D	
<b>Moisture Resistance:</b> MIL-STD-202, Method 106	

## Material Specifications

(See non-magnetic materials page 10)

For more information, please contact customer service at (507) 833-8822 or (800) 247-8256 • [www.EmersonConnectivity.com](http://www.EmersonConnectivity.com)

Illustrations are shown in inches (millimeters).

# Flexible Cable and PC Mount

## Right Angle Crimp Type Plug – Captivated Contact

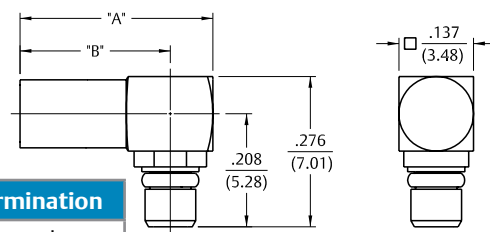

Cable Type	Gold Plated	"A"	"B"	Termination
RG-316, 188, 187, 179, 161, 174	135-9403-101	.412 (10.46)	.334 (8.48)	Crimp Sleeve
RG-178, 196	135-9402-111	.412 (10.46)	.334 (8.48)	Crimp Sleeve
.047 OD Flexible	135-9436-101	.354 (8.99)	.276 (6.98)	Crimp Insert

Assembly instructions page 199 and 200.

## Straight Crimp Type Plug – Solder or Crimp Contact – Captivated Contact

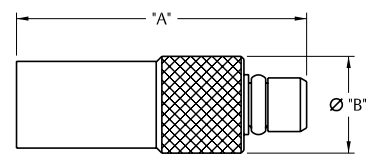

Cable Type	Gold Plated	"A"	"B"	Termination
RG-316, 188, 161, 174	135-9403-001	.509 (12.93)	.173 (4.39)	Crimp Sleeve
RG-178, 196	135-9402-001	.462 (11.73)	.137 (3.48)	Crimp Insert
.047 OD Flexible	135-9436-001	.462 (11.73)	.137 (7.01)	Crimp Insert

Assembly instructions page 204 and 205.

## Straight Jack Receptacle

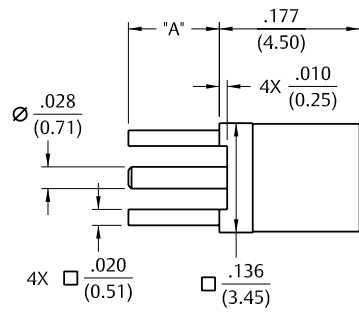

Gold Plated	"A"
135-9701-201	.115 (2.92)
135-9701-211	.068 (1.73)

Mounting hole layout figure 12 on page 195.

## Right Angle Jack Receptacle

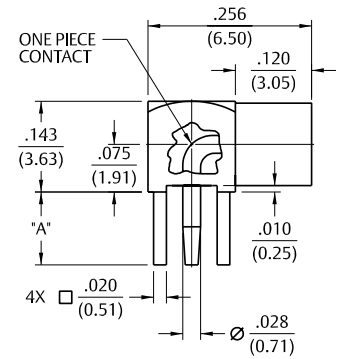

Gold Plated	"A"
135-9701-301	.155 (3.94)
135-9701-311	.068 (1.73)

Mounting hole layout figure 12 on page 195.

## End Launch Surface Mount Jack Receptacle

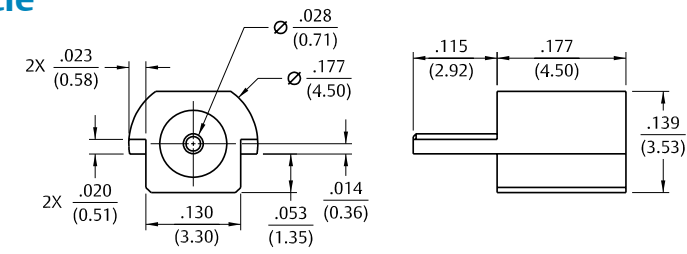

Gold Plated	Packaging
135-9711-801	Stock
135-9711-802	Tape and Reel 1000 pcs/reel

Recommended land pattern figure 14 on page 195.  
Tape and Reel .316 (8.0) component pitch .630 (16.0) wide.

## MCX Connectors

50 Ohm Connectors  
 Specifications.....14  
 Semi-Rigid & Flexible Cable.....16  
 PC Mount.....18  
 Bulkhead & Panel Mount.....22  
 Adapters.....23  
 Terminations.....23

Reverse Polarity 50 Ohm Connectors  
 Specifications.....24  
 Semi-Rigid & Flexible Cable.....26  
 PC Mount.....27

75 Ohm Connectors  
 Specifications.....28  
 Semi-Rigid & Flexible Cable.....31  
 PC Mount.....32  
 Adapters.....34  
 Terminations.....35

50 Ohm Non-Magnetic Connectors  
 Specifications.....36  
 Semi-Rigid & Flexible Cable.....37  
 PC Mount.....38

Other Information  
 Assembly Tools.....185  
 Capabilities.....190  
 Cable Information.....192  
 Assembly Instruction.....193  
 Mounting Hole Layouts.....194  
 Numerical Index.....274  
 Competitor Cross Reference.....280

3 **MMCX Connectors**

13 **MCX Connectors**

39 **SMK Connectors**

45 **SMA Connectors**

103 **SMB Connectors**

131 **SMC Connectors**

137 **SMP Connectors**

145 **Type N Connectors**

153 **Shielded Cable Terminations**

157 **Between-Series Adapters**

161 **Fixed Length Cable Assemblies**

173 **Ultra Miniature Connectors (UMC)**

181 **kwiQMate™ Connectors**

185 **Tools**

193 **Assembly Instructions**

257 **Electronic Hardware**

274 **Index**

While every precaution has been taken to ensure accuracy and completeness herein, Emerson Network Power Connectivity Solutions assumes no responsibility, and disclaims all liability for damages resulting from use of this information or for any errors or omissions. Specifications subject to change without notice.

# Specifications

## Electrical Specifications

**Impedance:** 50 Ohms

**Frequency Range:**

Connectors.....	0-6 GHz	
Dummy loads.....	0-1 GHz	

**VSWR:** (max) (f = GHz)

	Straight Cabled Connectors	Right Angle Cabled Connectors
RG-178.....	1.17 + .04f	1.07 + .06f
RG-316 and RG-405.....	1.13 + .04f	1.07 + .04f
Adapters.....	1.13 + .04f	

Uncabled receptacles, Dummy loads..... N/A

**Working Voltage:** (VRMS max)†

	Sea Level	70K Feet
RG-178.....	250	65
RG-316, RG-405, uncabled receptacles, adapters.....	335	85
Dummy loads.....	N/A	

**Dielectric Withstanding Voltage:** (VRMS min at sea level)†

RG-178.....	750
RG-316, RG-405, uncabled receptacles, adapters.....	1000
Dummy loads.....	N/A

**Insulation Resistance:** 1,000 megohms min

**Contact Resistance:** (milliohms max)

	Initial	After Environmental
Center contact (straight cabled connectors and uncabled receptacles).....	5.0	8.0
Center contact (right angle cabled connectors, adapters).....	5.0	15.0
Outer contact (all connectors).....	1.0	1.5
Braid to body (gold plated connectors).....	1.0	N/A
Braid to body (nickel plated connectors).....	2.5	N/A

**Corona Level:** (Volts min at 70,000 feet)

RG-178.....	190
RG-316, RG-405 uncabled receptacles, adapters.....	250
Dummy loads.....	N/A

**Insertion Loss:** (dB max tested at 1 GHz)

Straight cabled connectors, adapters.....	0.1 dB
Right angle cabled connectors.....	0.2 dB
Uncabled receptacles, dummy loads.....	N/A

**RF Leakage:** (dB min, tested at 2.5 GHz)

Cable connectors.....	-55 dB
Uncabled receptacles and adapters, dummy load.....	N/A

**RF High Potential Withstanding Voltage:** (VRMS min, tested at 4 and 7 MHz)†

RG-178.....	500
RG-316 and adapters.....	700
RG-405.....	670
Uncabled receptacles.....	600
Dummy loads.....	N/A

**Power Rating (Dummy Load):** 0.5 watt @ +25°C, derated to 0.25 watt @ +125°C

† Avoid user injury due to misapplication. See safety advisory definitions inside front cover.

## Mechanical Specifications

**Engagement Design:** Compatible with CECC 22220, Series MCX

**Engagement Force:** 5.6 lbs max axial force

**Disengagement Force:** 8 lbs max axial force, 1 lb min

**Contact Retention:** 2.3lbs min axial force (captivated contacts) 1 oz-in min torque (uncabled receptacles)

	Axial Force* (lbs)	Torque (oz-in)
RG-178.....	10.0	N/A
RG-316.....	20.0	N/A
RG-316 DS.....	25.0	N/A
RG-405.....	30.0	16

\*Or cable breaking strength whichever is less.

**Durability:** .....500 cycles min

## Environmental Specifications

(Meets or Exceeds the Applicable Paragraph of MIL-PRF-39012)

**Temperature Range:**

Connectors.....	- 65°C to + 165°C
Dummy loads.....	- 65°C to + 125°C

**Thermal Shock:** MIL-STD-202, Method 107, Condition F (N/A dummy loads)

**Corrosion:** MIL-STD-202, Method 101, Condition B (N/A dummy loads)

**Shock:** MIL-STD-202, Method 213, Condition B (N/A dummy loads)

**Vibration:** MIL-STD-202, Method 204, Condition B (N/A dummy loads)

**Moisture Resistance:** MIL-STD-202, Method 106 (N/A dummy loads)

## Material Specifications

**Bodies:** Brass per ASTM B16, gold plated\*\* per MIL-DTL-45204 .00001" min or nickel plated per AMS-QQ-N-290

**Contacts:** Male - brass per ASTM B16, gold plated per MIL-DTL-45204 .00003" min  
Female - beryllium copper per ASTM B196, gold plated per MIL-DTL-45204 .00003" min

**Insulators:** PTFE fluorocarbon per ASTM D 1710 and ASTM D 1457

**Expansion Caps:** Brass per ASTM B16, gold plated per MIL-DTL-45204 .00001" min or nickel plated per AMS-QQ-N-290

**Crimp Sleeves:** Copper per ASTM B301, gold plated per MIL-DTL-45204 .00001" min or nickel plated per AMS-QQ-N-290

**Mounting Hardware:** Brass (nuts) per ASTM B16 or phosphor bronze (lockwashers) per ASTM B139, gold plated per MIL-DTL-45204 .00001" min or nickel plated per AMS-QQ-N-290

\*\* All gold plated parts include a .00005" min. nickel underplate barrier layer.

## Mating Engagement for MCX Series Compatible with CECC 22220

1. ID of contact to meet VSWR mating characteristics and connector durability when mated with a dia. .019-.021 (0.48-0.53) male contact.
2. Must meet the force to engage and disengage when mated with mating part.

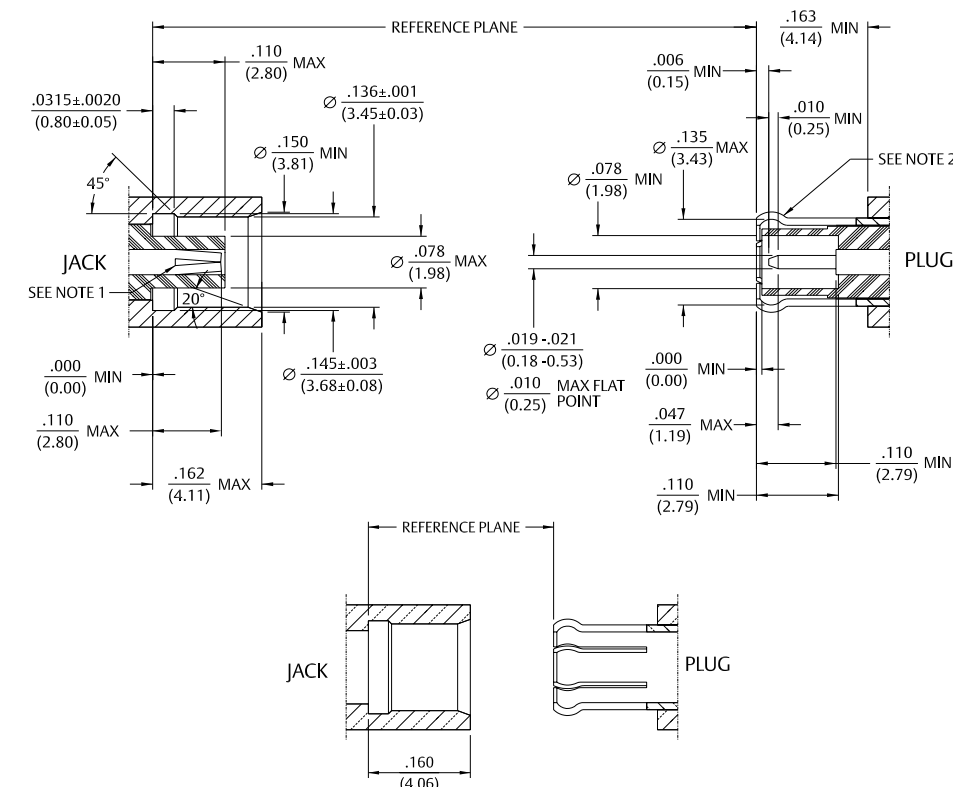

For more information, please contact customer service at (507) 833-8822 or (800) 247-8256 • www.EmersonConnectivity.com

Illustrations are shown in inches (millimeters).



# Semi-Rigid Cable & Flexible Cable

## Straight Solder Type Plug

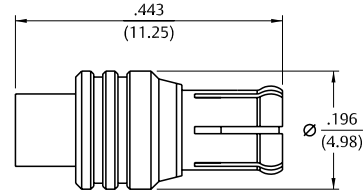

Cable Type	Gold Plated	Nickel Plated
RG-405	133-3693-001	133-3693-006

Assembly instructions page 206.

## Right Angle Solder Type Plug – Captivated Contact

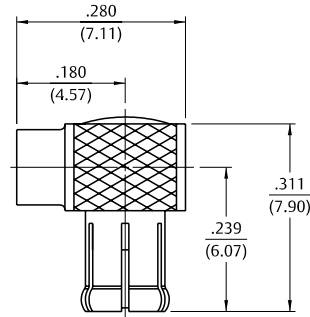

Cable Type	Gold Plated	Nickel Plated
RG-405	133-3693-101	133-3693-106

Assembly instructions page 206.

## Straight Crimp Type Plug – Solder or Crimp Contact

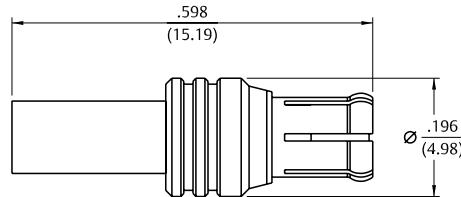

Cable Type	Gold Plated	Nickel Plated	Captivated Contact
RG-178, 196	133-3402-001	133-3402-006	No
RG-316, 188, 161, 174	133-3403-001	133-3403-006	Yes
RG-316 DS, 188DS	133-3404-001	133-3404-006	Yes
RG-179, 187	133-3433-001	133-3433-006	Yes

Assembly instructions page 207.

# Flexible Cable

## Right Angle Crimp Type Plug – Captivated Contact

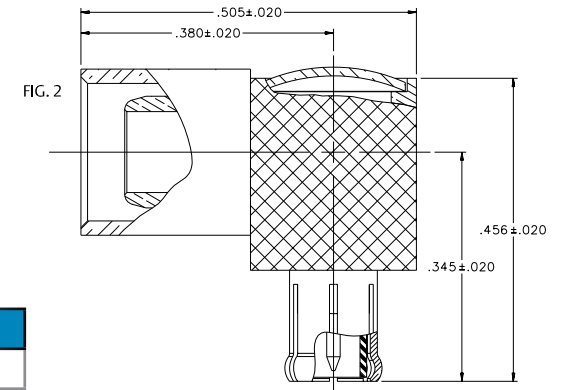
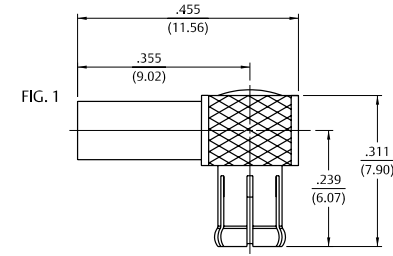

Cable Type	Gold Plated	Nickel Plated	Fig.
RG-178, 196	133-3402-101	133-3402-106	1
RG-316, 188, 161, 174	133-3403-101	133-3403-106	1
RG-316 DS, 188 DS	133-3404-101	133-3404-106	1
RG-58, 303, 141	133-3407-101	133-3407-106	2
RG-179, 187	133-3433-101	133-3433-106	1

Assembly instructions page 210.

## Straight Crimp Type Jack – Solder or Crimp Contact

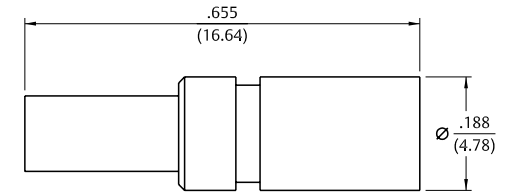

Cable Type	Gold Plated	Nickel Plated	Captivated Contact
RG-178, 196	133-3302-001	133-3302-006	No
RG-316, 188, 161, 174, 179, 187	133-3303-001	133-3303-006	Yes
RG-316 DS, 188 DS	133-3304-001	133-3304-006	Yes

Assembly instructions page 207.

## Straight Crimp Type Bulkhead Jack – Solder or Crimp Contact

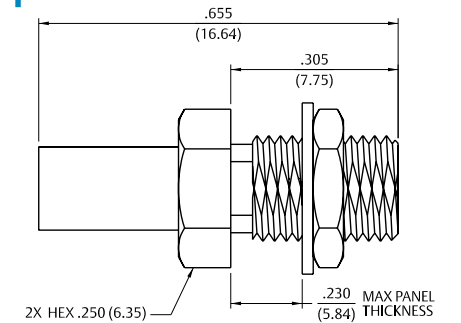

Cable Type	Gold Plated	Nickel Plated	Captivated Contact
RG-178, 196	133-3302-401	133-3302-406	No
RG-316, 188, 161, 174, 179, 187	133-3303-401	133-3303-406	Yes
RG-316 DS, 188 DS	133-3304-401	133-3304-406	Yes

Assembly instructions page 207. Mounting hole layout figure 5 page 194.

# PC Mount

## Straight Plug Receptacle



Gold Plated	Nickel Plated
133-3801-201	133-3801-206

Mounting hole layout figure 4 page 194.

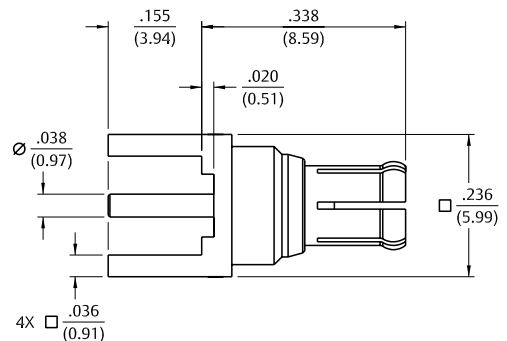

## Straight Plug Receptacle – Low Profile



Gold Plated	Nickel Plated
133-3801-211	133-3801-216

Mounting hole layout figure 4 page 194.

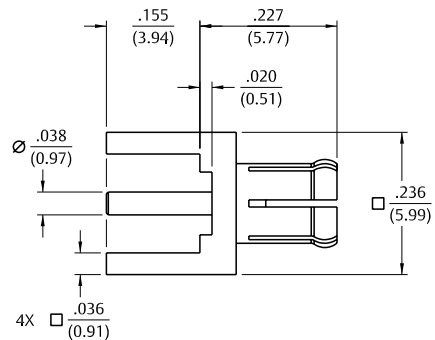

## Straight Jack Receptacle



Gold Plated	Nickel Plated	"A"
133-3701-201	133-3701-206	.155 (3.94)
133-3701-211	133-3701-216	.110 (2.79)
133-3701-221	133-3701-226	.068 (1.73)

Mounting hole layout figure 4 page 194.

Four and six connector ganged receptacles available. See page 190.

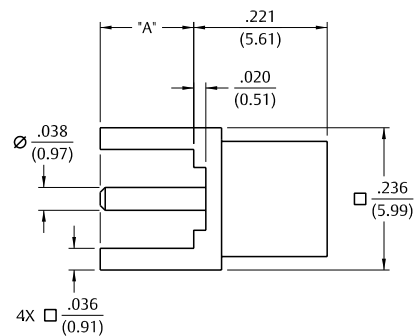

## PC Mount

## Straight Jack Receptacle – .100" Layout



Gold Plated	Nickel Plated
133-3701-231	133-3701-236

Mounting hole layout figure 12 page 194.

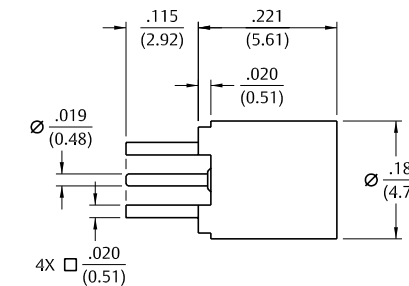

## Straight Surface Mount Jack Receptacle



Gold Plated	Packaging
133-3711-201	Stock
133-3711-202	Tape and Reel 750 pcs/reel

Recommended land pattern figure 13 on page 195.  
Tape and Reel .315 (8.0) component pitch .630 (16.0) wide.

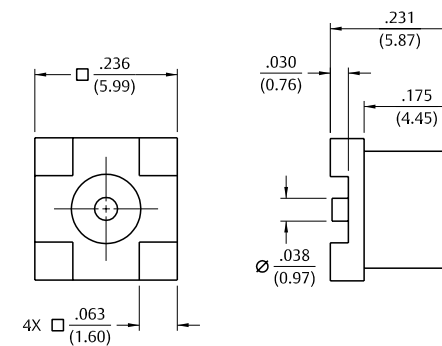

## Straight Surface Mount Jack Receptacle



Gold Plated	Packaging
133-3711-211	Stock
133-3711-212	Tape and Reel 750 pcs/reel

Recommended land pattern figure 13 on page 195.  
Tape and Reel .472 (12.0) component pitch .630 (16.0) wide.

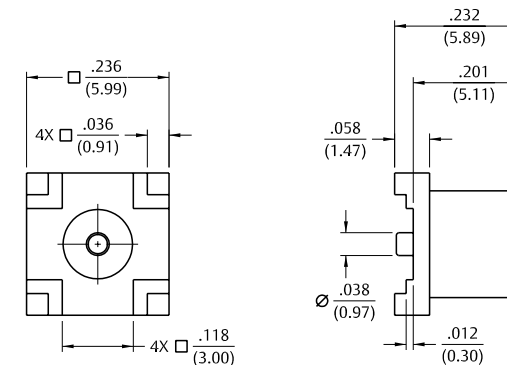

# PC Mount

## Right Angle Jack Receptacle



Gold Plated	Nickel Plated	"A"
133-3701-301	133-3701-306	.155 (3.94)
133-3701-311	133-3701-316	.110 (2.79)
133-3701-321	133-3701-326	.068 (1.73)

Mounting hole layout figure 4 page 194.

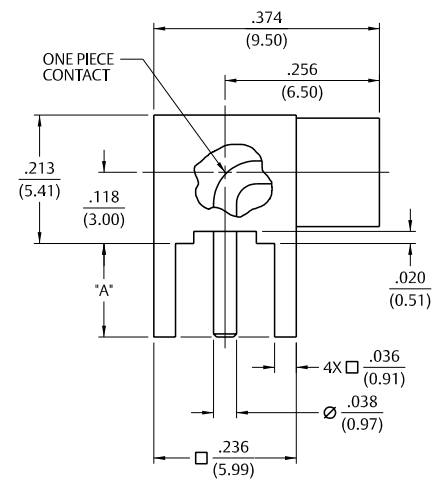

## Right Angle Surface Mount Jack Receptacle



Gold Plated	Packaging
133-3711-301	Stock
133-3711-302	Tape and Reel 750 pcs/reel

Recommended land pattern figure 13 on page 195.  
Tape and Reel .472 (12.0) component pitch .945 (24.0) wide.

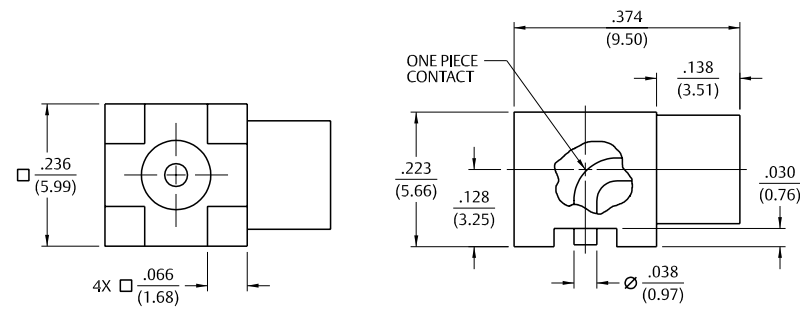

## Right Angle Surface Mount Jack Receptacle



Gold Plated	Packaging
133-3711-311	Stock
133-3711-312	Tape and Reel 750 pcs/reel

Recommended land pattern figure 4 on page 194.  
Tape and Reel .472 (12.0) component pitch .945 (24.0) wide.

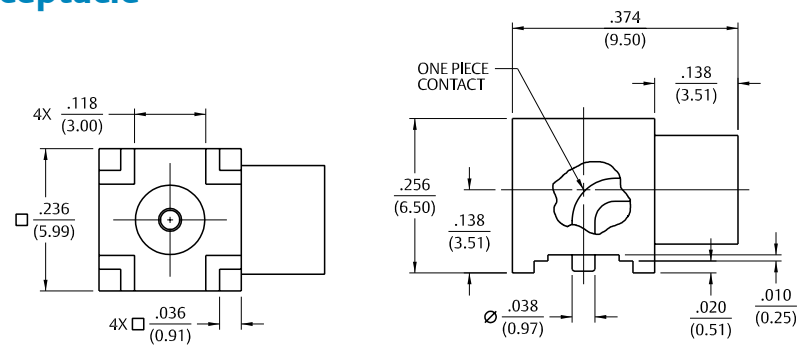

## End Launch Plug Receptacle



Gold Plated	Nickel Plated	Board Thickness	"A"	"B"
133-3801-841	133-3801-846	.062 (1.57)	.068 (1.73)	.048 (1.22)
133-3801-851	133-3801-856	.042 (1.07)	.048 (1.22)	.068 (1.73)

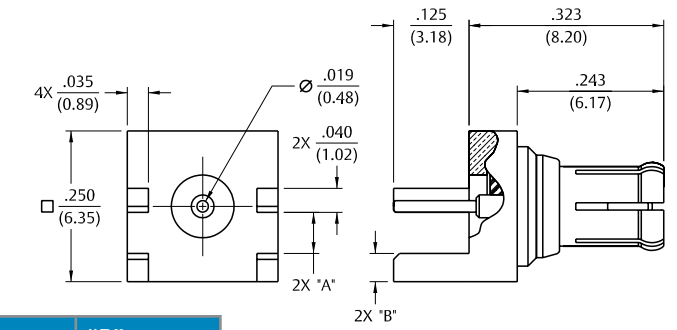

## End Launch Jack Receptacle



Gold Plated	Nickel Plated	Board Thickness	"A"	"B"
133-3701-801	133-3701-806	.062 (1.57)	.068 (1.73)	.048 (1.22)
133-3701-811	133-3701-816	.042 (1.07)	.048 (1.22)	.068 (1.73)

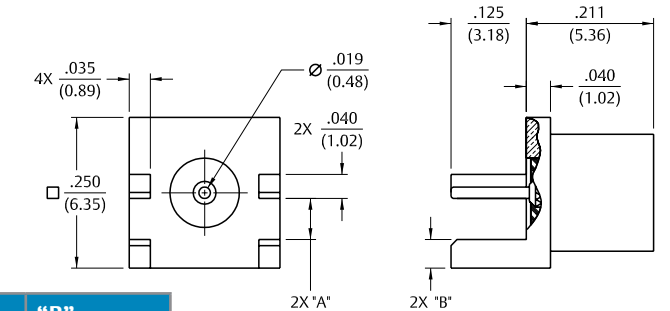

## End Launch Bulkhead Jack Receptacle



Gold Plated	Nickel Plated	Board Thickness
133-3701-821	133-3701-826	.062 (1.57)

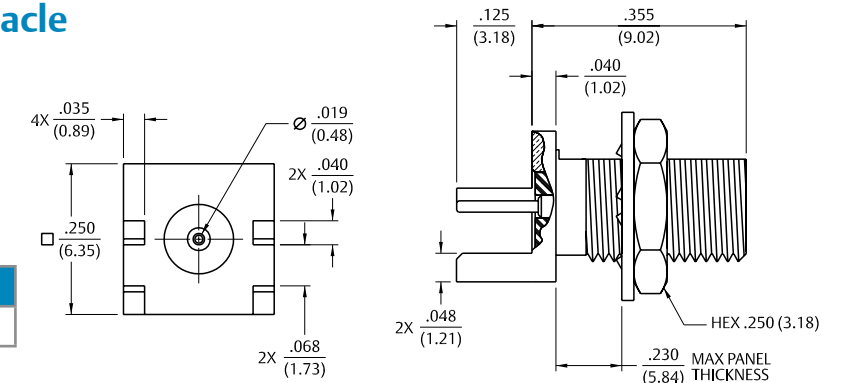

# PC Mount

# PC Mount, Bulkhead Mount & Panel Mount

## End Launch Surface Mount Jack Receptacle



Gold Plated	Packaging
133-3711-801	Stock
133-3711-802	Tape and Reel 1000 pcs/reel

Recommended land pattern figure 21 page 195.  
Tape and Reel .472 (12.0) component pitch .945 (24.0) wide

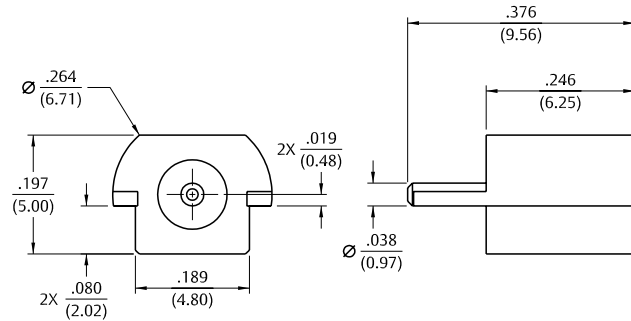

## Front Mount Bulkhead Jack Receptacle



Gold Plated	Nickel Plated	Mounting Style	Fig
133-3701-401	133-3701-406	D Flat Threaded	1
133-3701-411	133-3701-416	Press Fit Knurl	2

Mounting hole layout for 133-3701-401 figure 5 page 194.  
Mounting hole layout for 133-3701-406 figure 5 page 194.  
Mounting hole layout for 133-3701-411 figure 10 page 194.  
Mounting hole layout for 133-3701-416 figure 10 page 194.

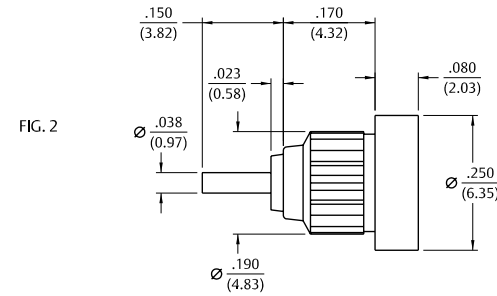
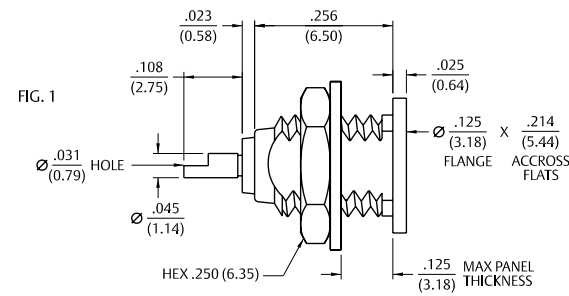

## 2-Hole Flange Mount Jack Receptacle – Flush Dielectric



Gold Plated	Nickel Plated
133-3701-601	133-3701-606

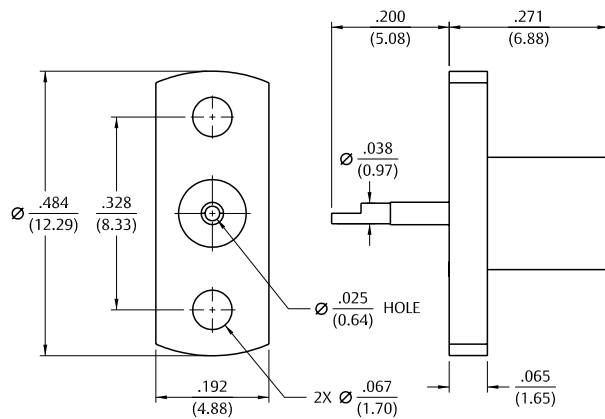

# Panel Mount, In-Series Adapters & Terminations

## 2-Hole Flange Mount Jack Receptacle – Extended Dielectric



Gold Plated	Nickel Plated	"A"	"B"
133-3701-611	133-3701-616	.170 (4.32)	.092 (2.34)
133-3701-621	133-3701-626	.300 (7.62)	.200 (5.08)

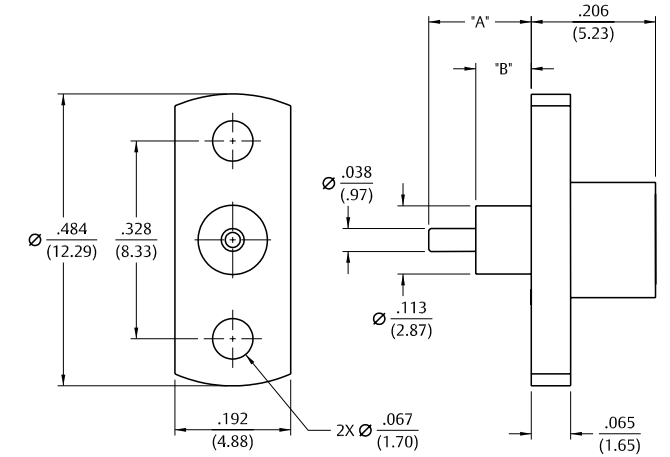

## Jack to Jack Adapter



Gold Plated	Nickel Plated
133-3901-801	133-3901-806

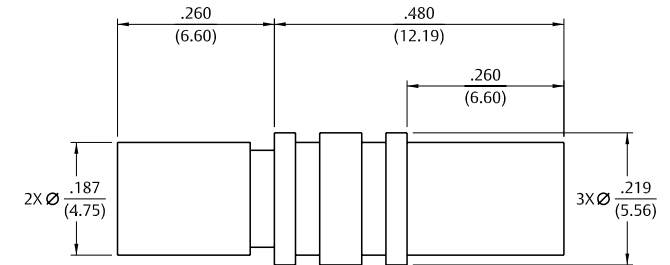

## Jack to Bulkhead Jack Adapter



Gold Plated	Nickel Plated
133-3901-401	133-3901-406

Mounting hole layout figure 5 page 194.

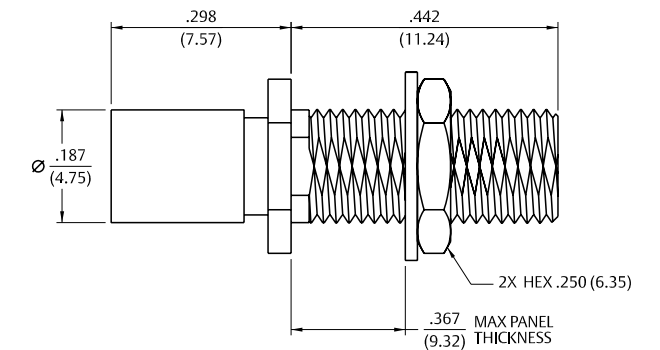

## Plug Dummy Load



Freq. Range	Gold Plated	Nickel Plated	Resistance
0-1 GHz	133-3801-801	133-3801-806	50 Ohm
0-1 GHz	133-3801-821	133-3801-826	75 Ohm

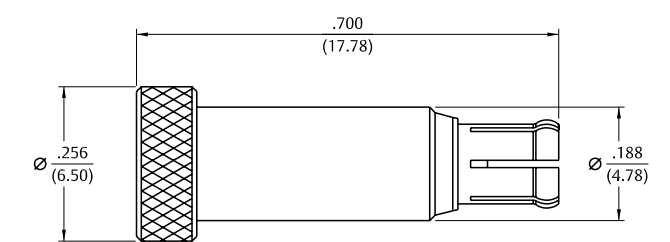

# Specifications

## Electrical Specifications

**Impedance:** 50 Ohms  
**Frequency Range:** .....0-6 GHz  
**VSWR (max):** (f=GHz)

	Straight Cabled Connectors	Right Angle Cabled Connectors
RG-178.....	1.17 + .04f	1.07 + .06f
RG-316.....	1.13 + .04f	1.07 + .04f
Uncabled receptacles.....	N/A	

**Working Voltage:** (VRMS max)†

	Sea Level	70K Feet
RG-178.....	250	65
RG-316.....	335	85

**Dielectric Withstanding Voltage:** (VRMS min at sea level)†

RG-178.....	750
RG-316, uncabled receptacles.....	1000

**Corona Level:** (Volts min at 70,000 feet)

RG-178.....	190
RG-316, uncabled receptacles.....	250

**Insertion Loss:** (dB max tested at 1 GHz)

Straight cabled connectors.....	0.1 dB
Right angle cabled connectors.....	0.2 dB
Uncabled receptacles.....	N/A

**Insulation Resistance:** 1000 megohms min  
**Contact Resistance:** (milliohms max)

	Initial	After Environmental
Center contact (straight cabled connectors and uncabled receptacles).....	5.0	8.0
Center contact (right angle cabled connectors).....	5.0	15.0
Outer contact (all connectors).....	1.0	1.5
Braid to body (gold plated connectors).....	1.0	N/A
Braid to body (nickel plated connectors).....	2.5	N/A

**RF Leakage:** (dB min, tested at 2.5 GHz)

Cable connectors.....	-55 dB
Uncabled receptacles.....	N/A

**RF High Potential Withstanding Voltage:** (VRMS min tested at 4 and 7 MHz) †

RG-178.....	500
RG-316.....	700
Uncabled receptacles.....	600

† Avoid user injury due to misapplication. See safety advisory definitions.

## Mechanical Specifications

**Engagement Force:** 5.6 lbs max axial force  
**Disengagement Force:** 8 lbs max axial force, 1 lbs min.  
**Contact Retention:** 2.3 lbs min axial force (captivated contacts) 1 oz-in min torque (uncabled receptacles)  
**Cable Retention:**

	Axial Force* (lbs)	Torque (oz-in)
RG-178.....	10.0	N/A
RG-316.....	20.0	N/A
RG-316 DS.....	25.0	N/A

\*Or cable breaking strength whichever is less.  
**Durability:**.....500 cycles min

## Environmental Specifications

(Meets or Exceeds the Applicable Paragraph of MIL-PRF-39012)

**Temperature Range:** ..... - 65°C to + 165°C  
**Thermal Shock:** MIL-STD-202, Method 107, Condition F  
**Corrosion:** MIL-STD-202, Method 101, Condition B  
**Shock:** MIL-STD-202, Method 213, Condition B  
**Vibration:** MIL-STD-202, Method 204, Condition B  
**Moisture Resistance:** MIL-STD-202, Method 106

# Specifications

## Material Specifications

**Bodies:** Brass per ASTM B16 or zinc per ASTM B86-71, gold plated\*\* per MIL-DTL-45204 .00001" min or nickel plated per AMS-QQ-N-290  
**Contacts:** Male - brass per ASTM B16, gold plated per MIL-DTL-45204 .00003" min  
 Female - beryllium copper per ASTM B196, gold plated per MIL-DTL-45204 .00003" min  
**Insulators:** PTFE fluorocarbon per ASTM D 1710 and ASTM D 1457  
**Expansion Caps:** Brass per ASTM B16, gold plated per MIL-DTL-45204 .00001" min or nickel plated per AMS-QQ-N-290  
**Crimp Sleeves:** Copper per ASTM B301, gold plated per MIL-DTL-45204 .00001" min or nickel plated per AMS-QQ-N-290  
**Mounting Hardware:** Brass (nuts) per ASTM B16 or phosphor bronze (lockwashers) ASTM B139, gold plated per MIL-DTL-45204 .00001" min or nickel plated per AMS-QQ-N-290

\*\* All gold plated parts include a .00005" min. nickel underplate barrier layer.

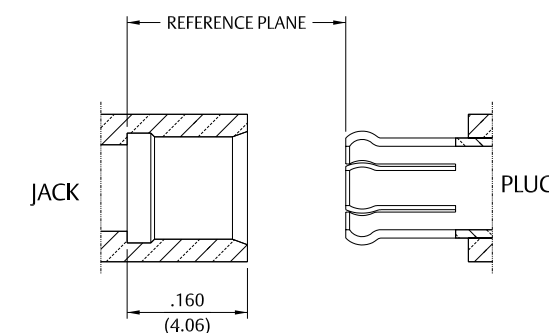
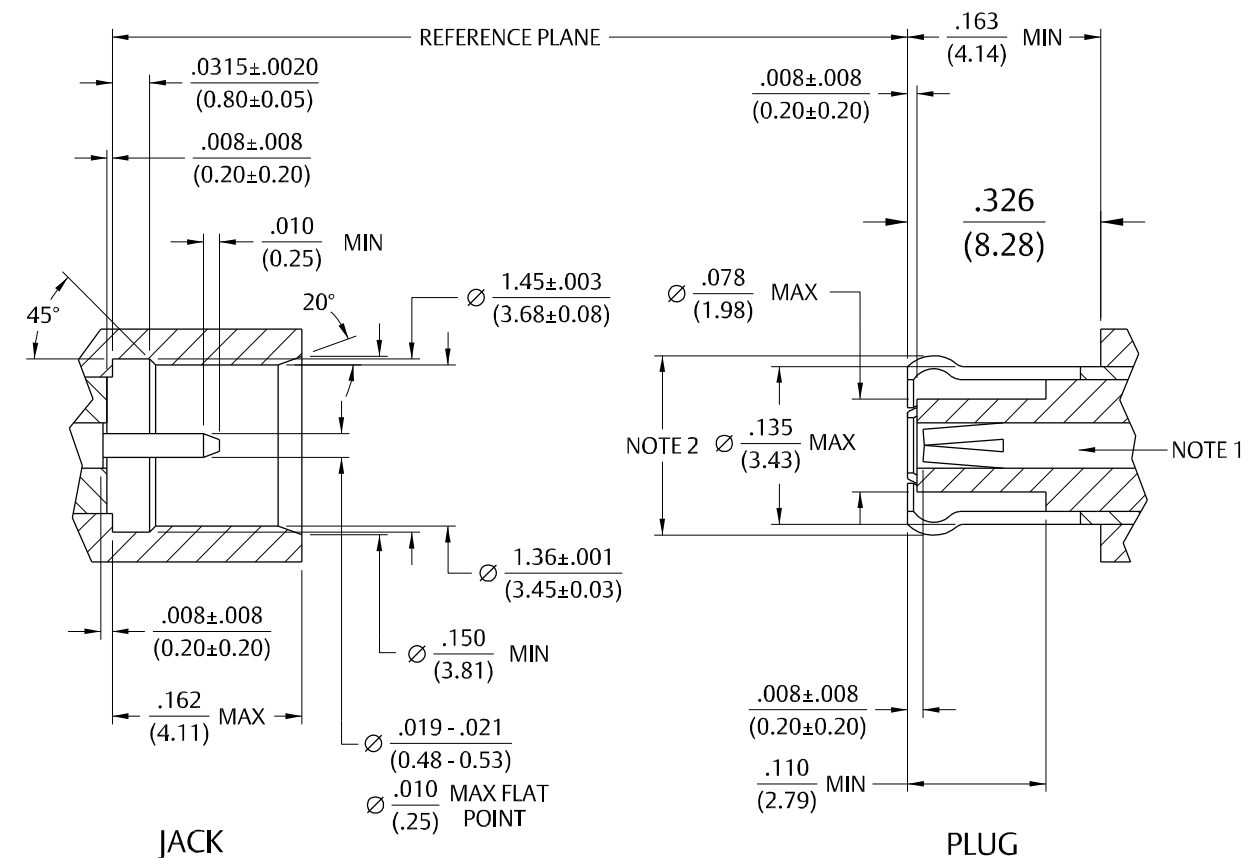

Notes:

1. ID of contact to meet VSWR mating characteristics and connector durability when mated with a dia. .019-.021 (.48-.53) male contact.
2. Must meet the force to engage and disengage when mated with mating part.

For more information, please contact customer service at (507) 833-8822 or (800) 247-8256 • www.EmersonConnectivity.com

Illustrations are shown in inches (millimeters).

# Flexible Cable

## Straight Crimp Type Plug – Solder or Crimp Contact

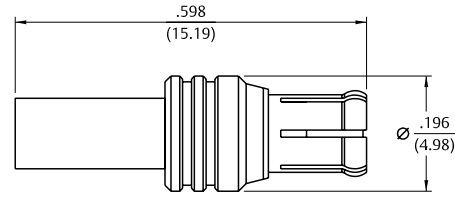

Cable Type	Gold Plated	Nickel Plated	Captivated Contact
RG-178, 196	133-5402-001	133-5402-006	No
RG-316, 188, 161, 174	133-5403-001	133-5403-006	Yes
RG-316 DS, 188 DS	133-5404-001	133-5404-006	Yes

Assembly instructions page 207.

## Right Angle Crimp Type Plug – Captivated Contact

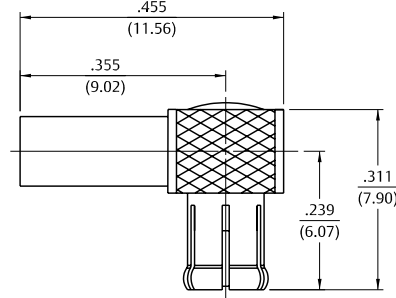

Cable Type	Gold Plated	Nickel Plated
RG-178, 196	133-5402-101	133-5402-106
RG-316, 188, 161, 174	133-5403-101	133-5403-106
RG-316 DS, 188 DS	133-5404-101	133-5404-106

Assembly instructions page 210.

## Straight Crimp Type Bulkhead Jack – Solder or Crimp Contact

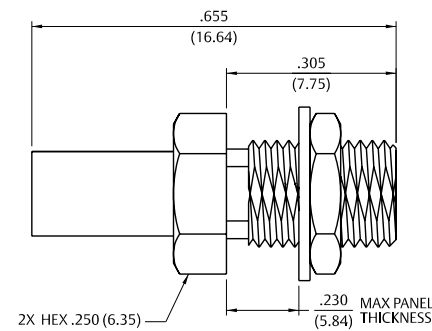

Cable Type	Gold Plated	Nickel Plated	Captivated Contact
RG-178, 196	133-5302-401	133-5302-406	No
RG-316, 188, 161, 174	133-5303-401	133-5303-406	Yes
RG-316 DS, 188 DS	133-5304-401	133-5304-406	Yes

Mounting hole layout figure 5 page 194.  
Assembly instructions page 207.

## Straight Jack Receptacle



Gold Plated	Nickel Plated
133-5701-201	133-5701-206

Mounting hole layout figure 4 page 194.

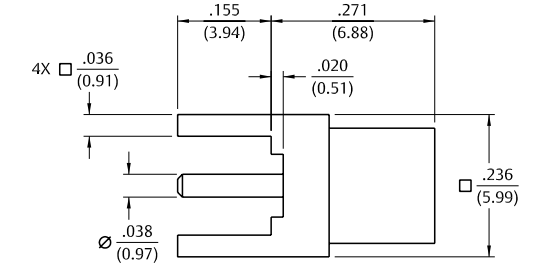

## End Launch Bulkhead Jack Receptacle



Gold Plated	Nickel Plated
133-5701-801	133-5701-806

Mounting hole layout figure 4 page 194.

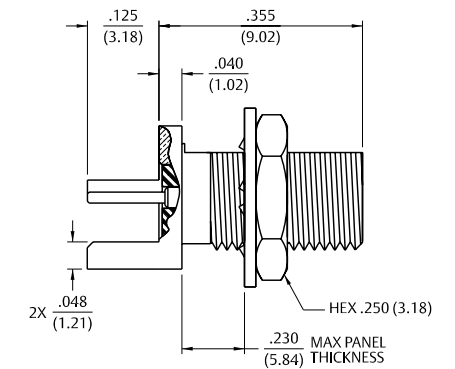
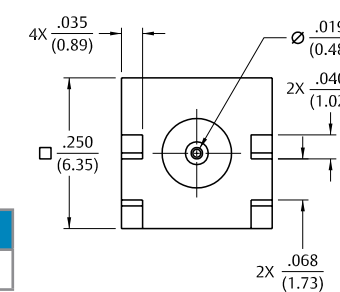

# Specifications

## Electrical Specifications

**Impedance:** 75 Ohms  
**Frequency Range:** ..... 0-6 GHz  
**VSWR:** (max) (f=GHz)

	Straight Cabled Connectors	Right Angle Cabled Connectors
RG-179 .....	1.13 + .04f	1.07 + .04f
In-series adapters .....	1.07 + .03f	
Between-series adapters, loads .....	1.05 + .01f	
Uncabled receptacles.....		N/A

**Working Voltage:** (VRMS max)†

	Sea Level	70K Feet
RG-179 .....	335	85
Uncabled receptacles, adapters .....	335	85
Loads, matching pad.....		N/A

**Dielectric Withstanding Voltage:** (VRMS min at sea level)†

RG-179 .....	1000
Uncabled receptacles, adapters .....	1000
Loads.....	N/A

**Insulation Resistance:** 1,000 megohms min  
**Contact Resistance:** (milliohms max)

	Initial	After Environmental
Center contact (straight cabled connectors and uncabled receptacles).....	5.0	8.0
Center contact (right angle cabled connectors, adapters).....	10.0	15.0
Center contact (loads).....	N/A	
Outer contact.....	1.0	1.5
Braid to body (gold plated connectors).....	1.0	N/A

**Corona Level:** (Volts min at 70,000 feet) †

RG-179 .....	250
Uncabled receptacles, adapters .....	250
Loads matching pad.....	N/A

**Insertion Loss:** (dB max tested at 1 GHz)

Straight cabled connectors .....	0.1 dB
Right angle cabled connectors.....	0.2 dB
Uncabled receptacles, adapters.....	N/A

**RF Leakage:** (dB min, tested at 2.5 GHz)

Cable connectors .....	-55 dB typical
Uncabled receptacles, adapters, loads .....	N/A

**RF High Potential Withstanding Voltage:** (VRMS min, tested at 4 and 7 MHz)†

Cabled Connectors for RG-179 .....	700
Uncabled receptacles, adapters .....	600
Loads .....	N/A

**Power Rating:** (Loads) 1.0 Watt at +25°C, derated linearly to 0.5 Watts at +125°C

† Avoid user injury due to misapplication. See safety advisory definitions inside front cover.

# Specifications

## Mechanical Specifications

**Engagement Design:** Compatible with CECC 22220, Series MCX 50 Ohm  
**Engagement Force:** 5.6 lbs max axial force  
**Disengagement Force:** 8 lbs max axial force, 1 lb min  
**Contact Retention:** 2.3 lbs min axial force (captivated contacts) 1 oz-in - min torque (uncabled receptacles)

	Axial Force (lbs) *	Torque (oz-in)
RG-179, BELDEN 735A .....	20.0	N/A
RG-179 DS.....	25.0	N/A

\*Or cable breaking strength whichever is less.  
**Durability:** ..... 500 cycles min

## Environmental Specifications

(Meets or Exceeds the Applicable Paragraph of MIL-PRF-39012)

**Temperature Range:**  
 All Connectors, Adapters..... -65°C to +165°C  
 Loads .....

**Thermal Shock:** MIL-STD-202, Method 107, Condition F (N/A Loads)  
**Temperature Coefficient:** Loads +/- 300ppm/°C  
**Corrosion:** MIL-STD-202, Method 101, Condition B (N/A Loads)  
**Shock:** MIL-STD-202, Method 213, Condition B (N/A Loads)  
**Vibration:** MIL-STD-202, Method 204, Condition B (N/A Loads)  
**Moisture Resistance:** MIL-STD-202, Method 106 (N/A Loads)

## Material Specifications

**Bodies:** Brass per ASTM B16, gold plated\*\* per MIL-DTL-45204 .00001" min or stainless steel, type 303 per ASTM A582, passivated per MIL-F-14072 (EL70)  
**Contacts:** Male - brass per ASTM B16, gold plated per MIL-DTL-45204 .00003" min  
 Female - beryllium copper per ASTM B196, gold plated per MIL-DTL-45204 .00003" min  
**Insulators:** PTFE fluorocarbon per ASTM D 1710 and ASTM D 1457  
**Expansion Caps:** Brass per ASTM B16, gold plated per MIL-DTL-45204 .00001" min  
**Crimp Sleeves:** Copper, gold plated per MIL-DTL-45204 .00001" min  
**Mounting Hardware:** Brass (nuts) per ASTM B16 or phosphor bronze (lockwashers) ASTM B139, gold plated per MIL-DTL-45204 .00001" min

\*\* All gold plated parts include a .00005" min. nickel underplate barrier layer.

# Specifications

## Mating Engagement for 75 Ohm MCX Series (Intermatable with CECC22220 50 Ohm MCX)

1. ID of contact to meet VSWR mating characteristics and connector durability when mated with a dia. .019-.021 (0.48-0.53) dia. male contact.
2. Must meet the force to engage and disengage when mated with mating part.
3. Interface shall intermate with MCX 50 Ohm interface per CECC 22220.

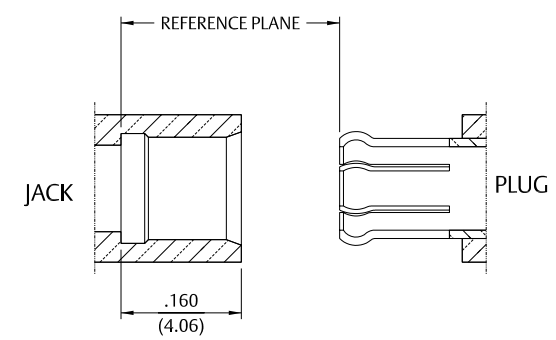
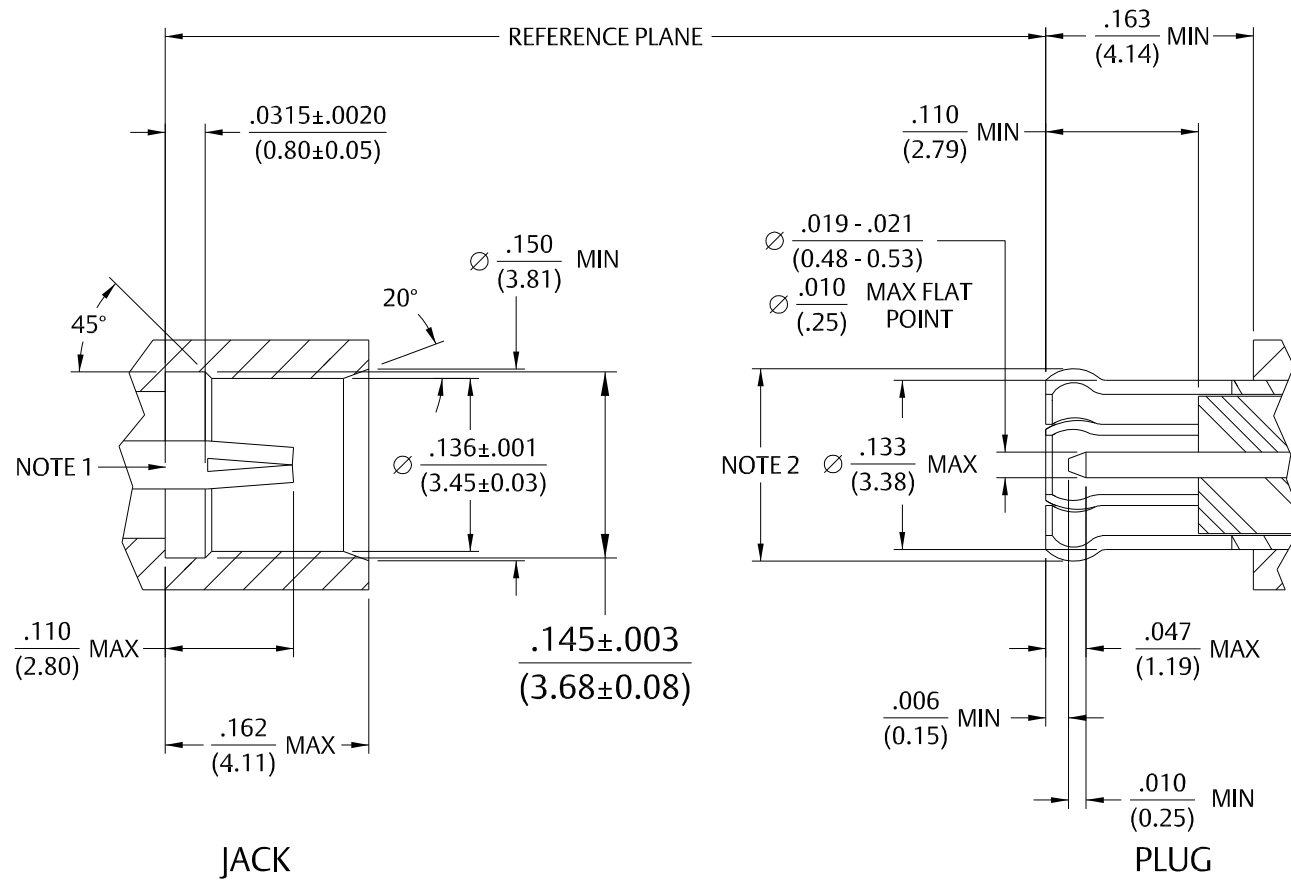

## Straight Crimp Type Plug – Solder or Crimp Captivated Contact

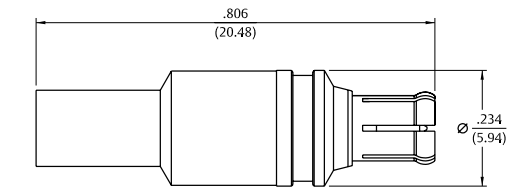

Cable Type	Gold Plated
RG-179	133-8433-001
RG-179 DS	133-8434-001
Belden 735A	133-8445-001

Assembly instructions page 209.

## Right Angle Crimp Type Plug – Captivated Contact

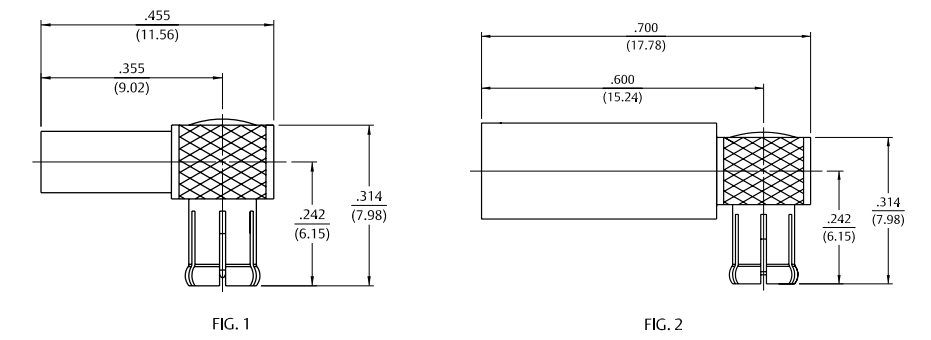

Cable Type	Gold Plated	Fig
RG-179	133-8433-101	1
RG-179 DS	133-8434-101	1
Belden 735A	133-8445-101	2

Assembly instructions page 211.

## Straight Crimp Type Jack – Solder or Crimp Captivated Contact

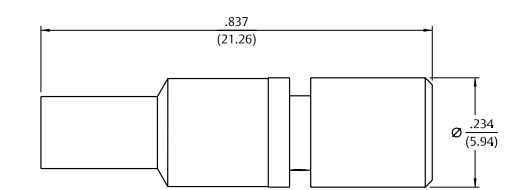

Cable Type	Gold Plated
RG-179	133-8333-001
RG-179 DS	133-8334-001

Assembly instructions page 209.



# Flexible Cable & PC Mount

## Straight Crimp Type Bulkhead Jack – Solder or Crimp Captivated Contact



Cable Type	Gold Plated
RG-179	133-8333-401
RG-179 DS	133-8334-401

Assembly instructions page 209.  
Mounting hole layout figure 5 page 194.

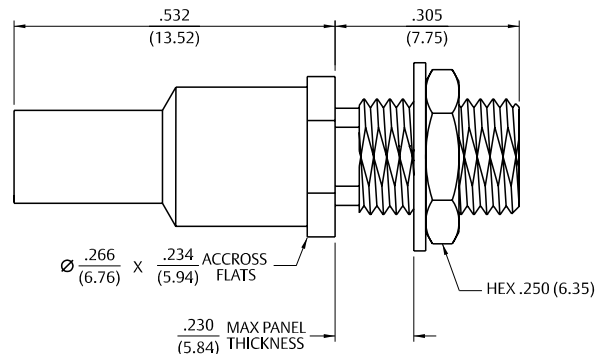

## Straight Plug Receptacle



Gold Plated	"A"	"B"
133-8801-201	.155 (3.80)	.343 (8.71)
133-8801-211	.110 (2.70)	.343 (8.71)
133-8801-221	.155 (3.80)	.510 (12.95)

Mounting hole layout figure 20 page 195.

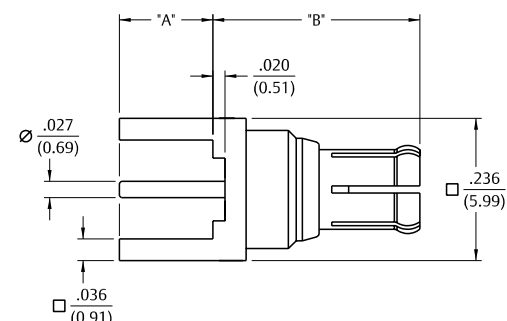

## Straight Jack Receptacle



Gold Plated	"A"
133-8701-201	.155 (3.80)
133-8701-211	.100 (2.54)

Mounting hole layout figure 20 page 195.

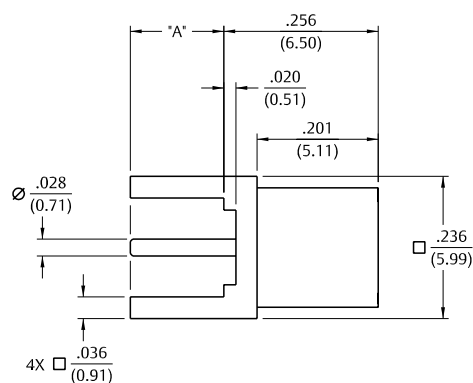

## Surface Mount Jack Receptacle



Gold Plated	Packaging
133-8711-201	Bulk Packs
133-8711-202	Tape and Reel 770 pcs/reel

Mounting hole layout figure 11 page 194.  
Tape and Reel .472 (12.0) component pitch .630 (16.0) wide.

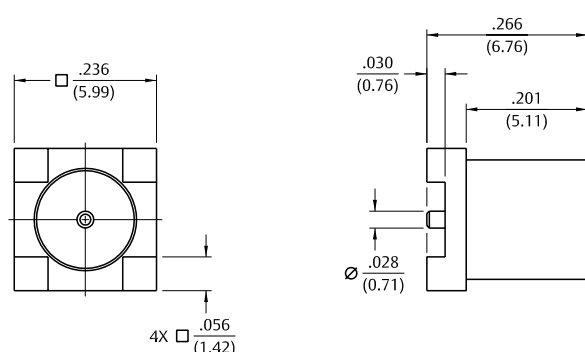

## Right Angle Jack Receptacle



Gold Plated	"A"
133-8701-301	.155 (3.80)
133-8701-311	.110 (2.70)

Mounting hole layout figure 20 page 195.

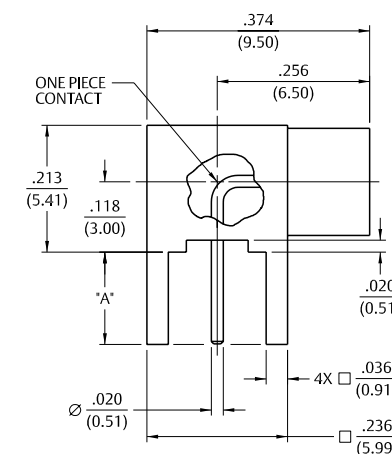

## End Launch Jack Receptacle



Cable Type	Board Thickness
133-8701-801	.062 (1.57)

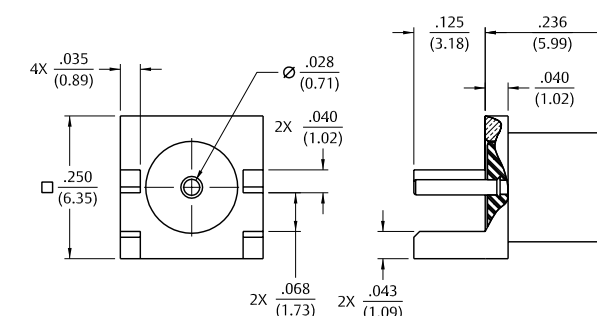

## Bulkhead Mount & In-Series Adapters

### Bulkhead Jack Receptacle



Gold Plated
133-8701-401

Mounting hole layout figure 1 page 194.

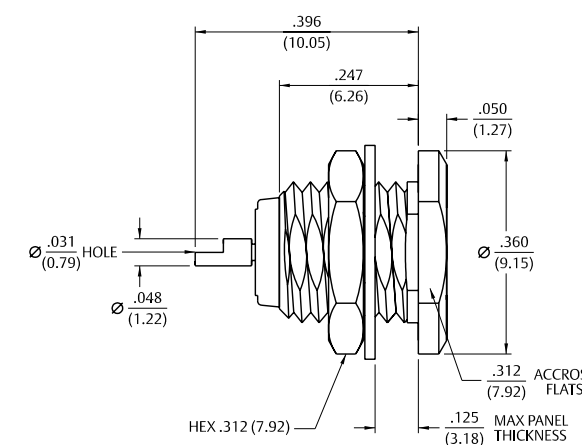

### Jack to Jack Adapter



Gold Plated
133-8901-801

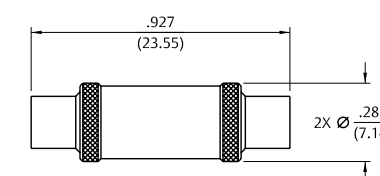

For more information, please contact customer service at (507) 833-8822 or (800) 247-8256 • [www.EmersonConnectivity.com](http://www.EmersonConnectivity.com)  
Illustrations are shown in inches (millimeters).

## Between-Series Adapters & Terminations

## In-Series Adapters & Between Series Adapters

### Jack to Plug Adapter



Gold Plated  
133-8901-821

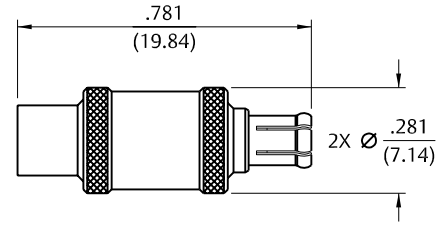

### 75 Ohm Type N Jack to 75 Ohm MCX Plug Adapter



Stainless Steel Passivated  
134-1068-021

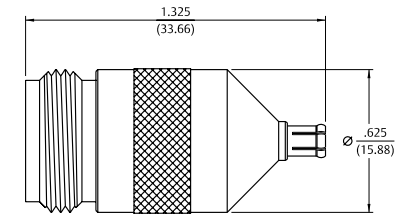

### 75 Ohm Type N Plug to 75 Ohm MCX Plug Adapter



Stainless Steel Passivated  
134-1068-001

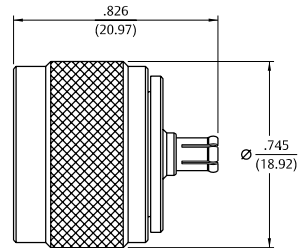

### 75 Ohm Type N Jack to 75 Ohm MCX Jack Adapter



Stainless Steel Passivated  
134-1068-031

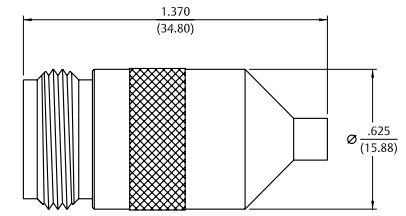

### 75 Ohm Type N Plug to 75 Ohm MCX Jack Adapter



Stainless Steel Passivated  
134-1068-011

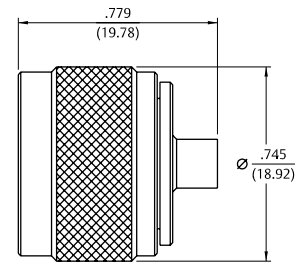

### Plug Precision Load



Gold Plated  
133-8801-831

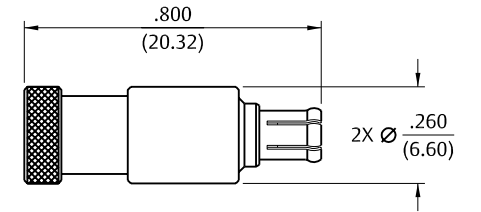

### Jack Precision Load



Gold Plated  
133-8701-831

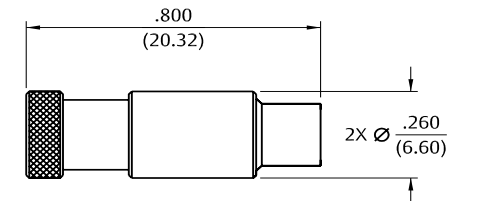

# Specifications

## Electrical Specifications

**Impedance:** 50 Ohms  
**Frequency Range:** ..... 0-6 GHz  
**VSWR (max):** (f = GHz)

	Straight Cabled Connectors	Right Angle Cabled Connectors
RG-316 cable.....	1.13 + .04f	1.07 + .04f
Uncabled receptacles.....	N/A	
<b>Working Voltage:</b> (VRMS max)†	<u>Sea Level</u>	<u>70K Feet</u>
RG-316 .....	335	85
<b>Dielectric Withstanding Voltage:</b> (VRMS min at sea level)†	1000	
<b>Insulation Resistance:</b> 1,000 megohms min		
<b>Contact Resistance:</b> (milliohms max)	<u>Initial</u>	<u>After Environmental</u>
Center contact (straight cabled connectors and uncabled receptacles).....	5.0	8.0
Center contact (right angle cabled connectors).....	5.0	15.0
Outer contact.....	1.0	1.5
Braid to body.....	1.0	N/A
<b>Corona Level:</b> (Volts min at 70,000 feet) †		
RG-316, uncabled receptacles .....	250	
<b>Insertion Loss:</b> (dB max tested at 1 GHz)		
Straight cabled connectors .....	0.1 dB	
Right angle cabled connectors .....	0.2 dB	
Uncabled receptacles .....	N/A	
<b>RF Leakage:</b> (dB min, tested at 2.5 GHz)		
Cabled connectors.....	-55 dB	
Uncabled receptacles .....	N/A	
<b>RF High Potential Withstanding Voltage:</b> (VRMS min tested at 4 and 7 MHz)		
Cabled Connectors .....	700	
Uncabled receptacles .....	600	

† Avoid user injury due to misapplication. See safety advisory definitions.

## Mechanical Specifications

**Engagement Design:** Compatible with CECC 22220, Series MCX 50 Ohm  
**Engagement Force:** 5.6 lbs max axial force  
**Disengagement Force:** 8 lbs max axial force, 1 lb min  
**Contact Retention:** 2.3 lbs min axial force (captivated contacts) 1 oz-in min torque (uncabled receptacles)

	Axial Force (lbs) *	Torque (oz-in)
RG-316.....	20.0	N/A
RG-316 DS.....	25.0	N/A

\*Or cable breaking strength whichever is less.  
**Durability:** .....500 cycles min

## Environmental Specifications

(Meets or Exceeds the Applicable Paragraph of MIL-PRF-39012)

**Temperature Range:** ..... - 65°C to + 165°C  
**Thermal Shock:** MIL-STD-202, Method 107, Condition F  
**Corrosion:** MIL-STD-202, Method 101, Condition B  
**Shock:** MIL-STD-202, Method 213, Condition B  
**Vibration:** MIL-STD-202, Method 204, Condition B  
**Moisture Resistance:** MIL-STD-202, Method 106

## Material Specifications

(See non-magnetic materials page 10)

# Non-Magnetic RF Connectors – For Flexible Cable

## Straight Crimp Type Plug – Solder or Crimp Contact – Captivated Contact

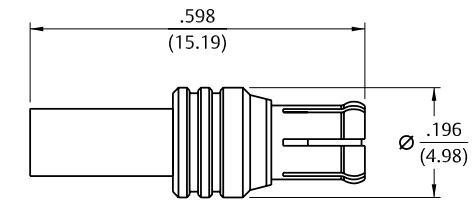

Cable Type	Gold Plated
RG-316, 188, 174	133-9403-001
RG-316 DS, 188 DS	133-9404-001

Assembly instructions page 208.

## Right Angle Crimp Type Plug – Captivated Contact

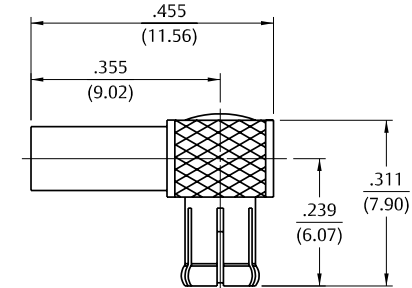

Cable Type	Gold Plated
RG-316, 188, 174	133-9403-101
RG-316 DS, 188 DS	133-9404-101

Assembly instructions page 207.

# Non-Magnetic RF Connectors – For PC Mount

## Straight Jack Receptacle



Gold Plated	"A"
133-9701-201	.155 (3.94)
133-9701-211	.110 (2.79)

Mounting hole layout figure 4 page 194.

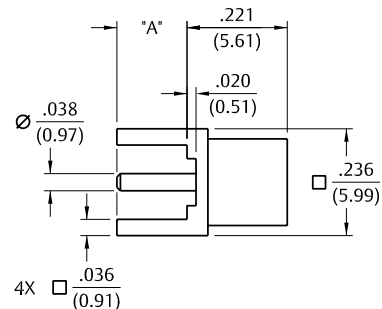

## Straight Jack Receptacle – .100" Layout



Gold Plated
133-9701-231

Mounting hole layout figure 12 page 194.

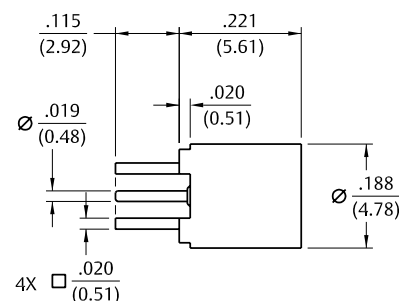

## Right Angle Jack Receptacle



Gold Plated	"A"
133-9701-301	.155 (3.94)
133-9701-311	.110 (2.79)

Mounting hole layout figure 4 page 194.

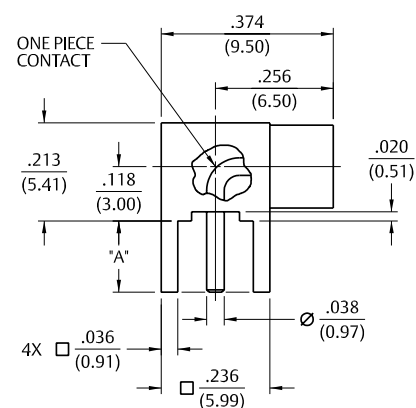

## End Launch Jack Receptacle – Round Contact



Gold Plated	Board Thickness
133-9701-801	.062 (1.57)

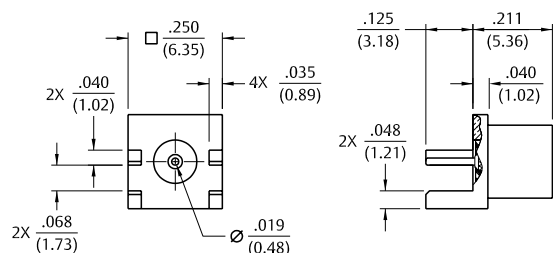

## SMK Connectors

50 Ohm Connectors  
 Specifications..... 40  
 Semi-Rigid & Flexible Cable.....43  
 Adapters ..... 44

Other Information  
 Assembly Tools ..... 185  
 Capabilities ..... 190  
 Cable Information ..... 192  
 Assembly Instruction ..... 193  
 Mounting Hole Layouts..... 194  
 Numerical Index..... 274  
 Competitor Cross Reference ..... 280

3	MMCX Connectors
13	MCX Connectors
39	SMK Connectors
45	SMA Connectors
103	SMB Connectors
131	SMC Connectors
137	SMP Connectors
145	Type N Connectors
153	Shielded Cable Terminations
157	Between-Series Adapters
161	Fixed Length Cable Assemblies
173	Ultra Miniature Connectors (UMC)
181	kwiQMate™ Connectors
185	Tools
193	Assembly Instructions
257	Electronic Hardware
274	Index

While every precaution has been taken to ensure accuracy and completeness herein, Emerson Network Power Connectivity Solutions assumes no responsibility, and disclaims all liability for damages resulting from use of this information or for any errors or omissions. Specifications subject to change without notice.

# Specifications

## SMK (2.92mm) Connectors

The Johnson line of SMK Connectors provides an excellent solution for demanding applications requiring high frequency transmission. Although similar to the SMA interface, a smaller internal body diameter (2.92mm) and air dielectric provide a higher cutoff frequency and other key advantages:

- Precision manufacturing allows superior electrical performance to 40 GHz
- Female contacts have a unique three-slot construction, which enhances connectivity by creating a more rugged connector while reducing the chance of intermittent connections
- Precise assembly tooling assures excellent, repeatable contact and support bead location on cabled connectors
- Connector mating interface per MIL-STD-348
- Mating interface control provides consistent electrical performance
- Plug connector VSWR is 1.20 Max to 40 GHz and a 12 inch SMK plug to plug cable assembly performs better than 1.35 VSWR to 40 GHz
- Field Replaceable Jacks are teamed with a high quality hermetic seal feed thru for use in sealed circuit modules
- SMK plug interface employs more precise dimensions than an SMA and uses a shorter snub nose male pin such that the connector bodies align before the contacts engage



## Electrical Specifications

<b>Impedance:</b>	50 Ohms	
<b>Frequency Range:</b>	0-40 GHz	
<b>VSWR (max):</b> (f = GHz)		
Semi-Rigid straight cabled connectors and adapters .....	1.20 max	
Field replaceable (see typical return loss graph) .....	N/A	
<b>Working Voltage:</b> (VRMS max)		
<b>Connectors for Cable Type</b>	<b>Sea Level</b>	<b>70K Feet</b>
RG-405 and field replaceable .....	335	85
RG-402 and adapters .....	500	125
<b>Dielectric Withstanding Voltage:</b> (VRMS min at sea level)		
RG-405 and field replaceable .....	1000	
RG-402 and adapters .....	1500	
<b>Corona Level:</b> (Volts min at 70,000 feet)		
RG-405 and field replaceable .....	250	
RG-402 and adapters .....	375	
<b>Insertion Loss:</b> (dB max)		
Adapters .....	0.06 f (GHz), tested at 6 GHz	
Straight Semi-Rigid cable connectors .....	0.03 f (GHz), tested at 10 GHz	
<b>Insulation Resistance:</b> 5000 megohms min		
<b>Contact Resistance:</b> (milliohms max)	<b>Initial</b>	<b>After Environmental</b>
Center contact straight cabled connectors .....	3.0*	4.0
Center contact adapters .....	4.0	6.0
Field replaceable connectors .....	6.0	8.0
Outer contact (all connectors) .....	2.0	N/A
Body to cable (gold plated connectors) .....	0.5	N/A
Body to cable (passivated connectors) .....	5.0	N/A
<b>RF Leakage:</b> (dB min, tested at 2.5 GHz) .....	-90dB	
<b>RF High Potential Withstanding Voltage:</b> (VRMS min., tested at 4 and 7 MHz)†		
RG-405 and field replaceable .....	670	
RG-402 and adapters .....	1000	

## Mechanical Specifications

<b>Engagement Design:</b>	MIL-STD-348, Series SMK (2.92mm)	
<b>Engagement/Disengagement Force:</b>	2 lb-in max	
<b>Mating Torque:</b>	7 to 10 in-lb	
<b>Bulkhead Mounting Nut Torque:</b>	15 in-lb	
<b>Coupling Proof Torque:</b>	15 in-lb min	
<b>Coupling Nut Retention:</b>	60 lbs min	
<b>Contact Retention:</b>	6 lbs min axial force (captivated contacts)	
<b>Cable Retention:</b>	<b>Axial Force* (lbs)</b>	<b>Torque (in-oz)</b>
RG-405 .....	30	16
RG-402 .....	60	55

\*Or cable breaking strength whichever is less  
 † Avoid user injury due to misapplication. See safety advisory definitions.

## Environmental Specifications

(Meets or Exceeds the Applicable Paragraph of MIL-PRF-C-39012)

- Temperature Range:** - 65°C to + 165°C
- Thermal Shock:** MIL-STD-202, Method 107, Condition B
- Corrosion:** MIL-STD-202, Method 101, Condition B
- Shock:** MIL-STD-202, Method 213, Condition I
- Vibration:** MIL-STD-202, Method 204, Condition D
- Moisture Resistance:** MIL-STD-202, Method 106

## Material Specifications

- Bodies:** Stainless steel per ASTM B16, gold plated\* per MIL-G-45204 .00005" min. or passivated per MIL-DTL-14072
  - Contacts:** Female - beryllium copper per ASTM B1960, gold plated per MIL-DTL-G-45204 .00005" min
  - Contact Support Beads:** PTFE fluorocarbon per ASTM D 1710 and ASTM D 1457 or modified PPE resin
  - Seal Rings:** Silicone rubber per ZZ-R-765
- \* All gold plated parts include a .00005" min. nickel underplate barrier layered

## Mating Engagement for SMK (2.92mm) Series

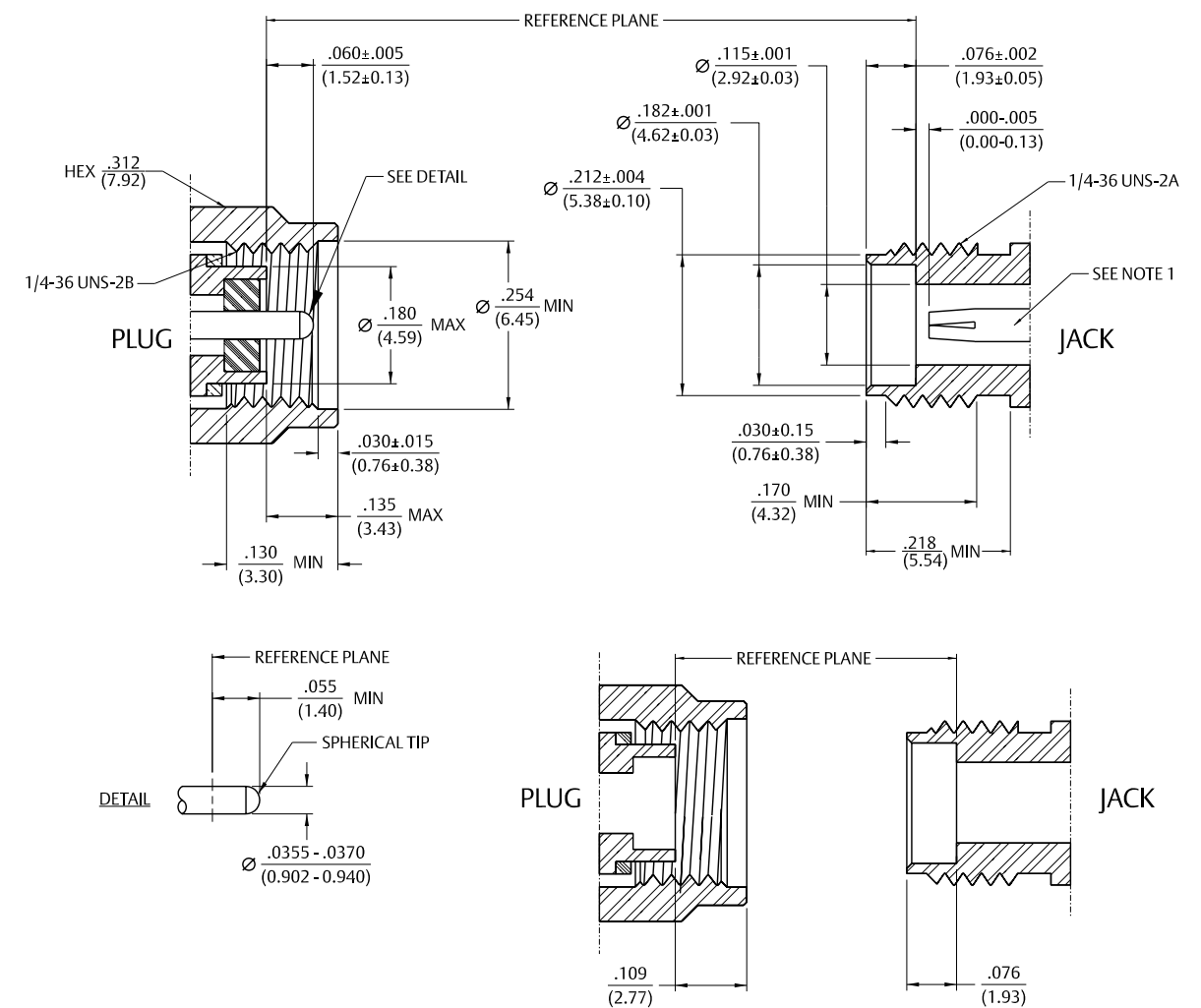

Notes:  
 1. ID of contact shall meet VSWR and connectivity requirements when mated with dia. .0355-.0365 male pin.

For more information, please contact customer service at (507) 833-8822 or (800) 247-8256 • www.EmersonConnectivity.com  
 Illustrations are shown in inches (millimeters).

# Specifications

## Field Replaceable Application Notes

These field replaceable connectors are easy to install and replace. The hermetic seal is mounted into the circuit module wall and the connector can be removed and replaced without destroying the hermeticity of the circuit housing.

The field replaceable connector creates a transition from microstrip circuitry to a coaxial transmission line. The SMK (2.92mm) seal pin diameter is .012 (.030) to minimize the capacitive effects on the circuit trace. For optimum electrical performance, the transition from the hermetic seal to the microstrip trace must be properly compensated which involves adjusting the microstrip trace width to minimize any impedance discontinuities found in the transition area.

The plot shown below is representative of the typical return loss of a Johnson field replaceable SMK connector. To produce the data shown below, a test fixture is created using the Johnson SMK hermetic seal. The fixture consists of a suitably thick spacer plate with the hermetic seal mounted flush to both surfaces. Two connectors are mounted back to back around the fixture and the VSWR of this test assembly is measured. The calculated return loss trace shown is equivalent to the square root of the measured VSWR of the test assembly. Since the connectors tested are of identical design, it can be stated with fair accuracy that the calculated data shown represents the response of a single field replaceable connector and its transition to the hermetic seal.

Although we do not publish a VSWR specification for field replaceable connectors, typical connector return loss can be expected to be better than 20 dB through 40 GHz. A VSWR specification is not stated because an industry standard method for testing field replaceable connectors does not exist. The actual performance of the connector is dependent upon the following:

1. For optimum electrical performance, we recommend the use of our standard 142-1000-033 hermetic seal with a pin diameter of .0120+/-0.0005 (0.305+/-0.013).
2. It is recommended that the hermetic seal be mounted flush with the circuit housing. Tolerance variations between the hermetic seal and machined housing do not always guarantee an optimum transition to the connector. Some manufacturers recommend an additional counterbore in the circuit housing to accommodate a solder washer during installation of the seal. We do not recommend this type of installation because, if the counterbore is not completely filled with solder, electrical discontinuities may be created.
3. The transition between the hermetic seal pin and the microstrip trace will effect electrical performance, as stated above. Several different methods of hermetic seal mounting and seal pin to microstrip trace attachment are used in the industry.

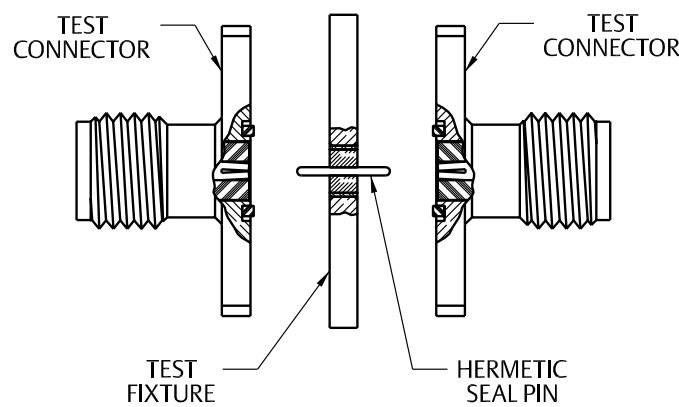

# Semi-Rigid Cable

## Straight Solder Type Plug – with Contact, Slide-On Nut

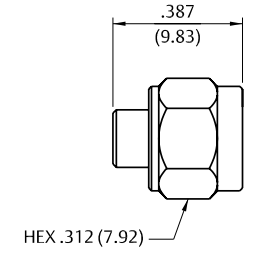

Cable Type	Gold Plated	Passivated*
RG-405 RG-402	145-0693-001	145-0693-002
RG-405 RG-402	145-0694-001	145-0694-002

Assembly instructions page 212.  
\*Passivated coupling nut with gold plated body.

## 2-Hole Flange Mount Jack Receptacle

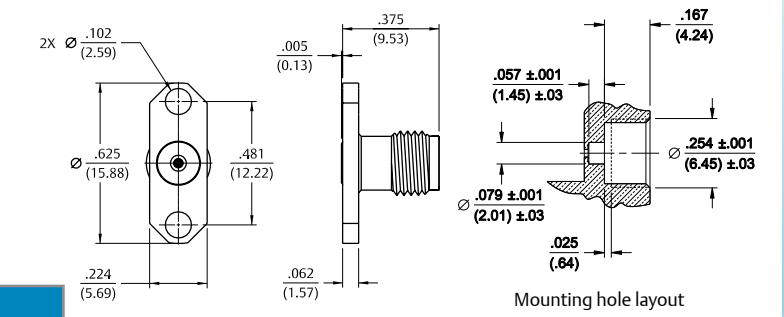

Gold Plated	Passivated	Accepts Pin Size
145-0701-601	145-0701-602	.0120+/-0.0005(0.305+/-0.013)

## 4-Hole Flange Mount Jack Receptacle

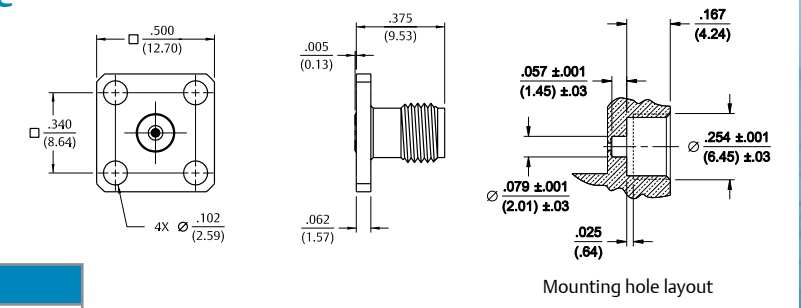

Gold Plated	Passivated	Accepts Pin Size
145-0701-611	145-0701-612	.0120+/-0.0005(0.305+/-0.013)

## Jack Receptacle – Thread Mount Field Replaceable

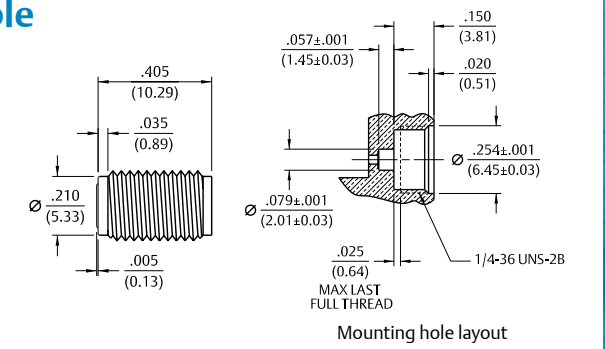

Gold Plated	Passivated	Accepts Pin Size
145-0701-001	145-0701-002	.0120 +/-0.0005 (0.305 +/-0.013)

For more information, please contact customer service at (507) 833-8822 or (800) 247-8256 • [www.EmersonConnectivity.com](http://www.EmersonConnectivity.com)  
Illustrations are shown in inches (millimeters).

# In-Series Adapters

## Hermetic Seal Feedthru

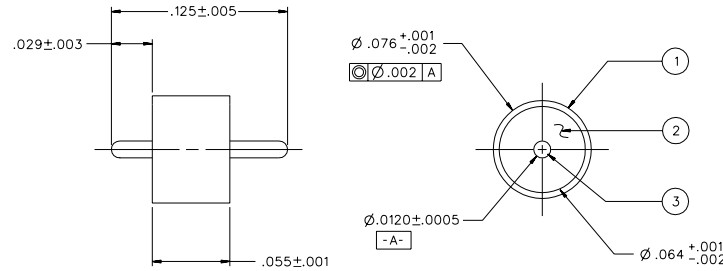

Part No.	Item 1 – Outer Ring	Item 2 – Insulator	Item 3 – Pin
142-1000-033	Kovar Gold Pl .00005 min over Nickel Pl .00005 min	Glass Corning 7070 Or Equivalent	Kovar Gold Pl .00005 min. over Nickel Pl .00005 min.

Notes:  
 1. The hermetic seal should be mounted as flush as possible with the housing. Excessive recession will create a high impedance air gap between connection and housing which degrades electrical performance.  
 2. The use of an additional counterbore to accommodate a solder ring for seal mounting is not recommended. A slight chamfer may be used if care is taken to completely fill the area with solder. **Avoid air gaps!**

### Electrical

**Impedance:** 50 Ohms  
**Frequency Range:** DC to 40 GHz  
**VSWR:** Dependent upon application  
**Working Voltage:** 250 VRMS max at sea level  
**Dielectric Withstanding Voltage:** 500 VRMS min at sea level  
**Insulation Resistance:** 5000 Megohm min  
**Insertion Loss:** 0.2 dB max at 40 GHz

### Environmental

**Hermeticity:** 1x10-8 cc/sec at one atmosphere  
**Solderability:** MIL-STD-202, Method 209  
**Operating Temperature:** -55° C to +165° C

## Jack to Jack In-Series Adapter



Gold Plated  
145-0901-801

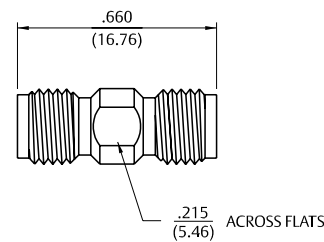

## Plug to Plug In-Series Adapter



Gold Plated  
145-0901-811

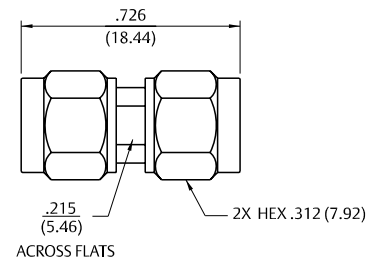

## Plug to Jack In-Series Adapter



Gold Plated  
145-0901-821

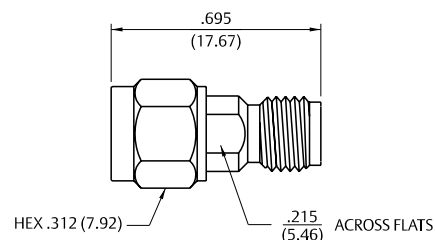

## SMA Connectors

50 Ohm Connectors

- Specifications..... 46
- Quick Connect ..... 49
- Semi-Rigid & Flexible Cable..... 50
- PC Mount ..... 56
- Bulkhead & Panel Mount ..... 62
- Self-Fixture End Launch..... 63
- Field Replaceable ..... 71
- Adapters ..... 76
- Terminations..... 77
- Reverse Polarity
- Specifications..... 78
- Semi-Rigid & Flexible Cable..... 80
- PC Mount ..... 81
- Reverse Thread
- Specifications..... 82
- Semi-Rigid & Flexible Cable..... 83
- PC Mount ..... 85
- 50 Ohm Non-Magnetic Connectors
- Specifications..... 86
- Semi-Rigid & Flexible Cable..... 87
- PC Mount ..... 88
- 50 Ohm High Frequency End Launch
- Specifications..... 90
- PC Mount ..... 92
- 50 Ohm Stainless Steel
- Specifications..... 94
- Semi-Rigid & Flexible Cable..... 97
- PC Mount ..... 100
- Bulkhead & Panel Mount ..... 100
- Fixed Attenuators
- Specifications..... 102
- Attenuators ..... 113
- Other Information
- Assembly Tools ..... 185
- Capabilities ..... 190
- Cable Information ..... 192
- Assembly Instruction ..... 193
- Mounting Hole Layouts ..... 194
- Numerical Index..... 274
- Competitor Cross Reference ..... 280

While every precaution has been taken to ensure accuracy and completeness herein, Emerson Network Power Connectivity Solutions assumes no responsibility, and disclaims all liability for damages resulting from use of this information or for any errors or omissions. Specifications subject to change without notice.

- 3 MMCX Connectors
- 13 MCX Connectors
- 39 SMK Connectors
- 45 SMA Connectors
- 103 SMB Connectors
- 131 SMC Connectors
- 137 SMP Connectors
- 145 Type N Connectors
- 153 Shielded Cable Terminations
- 157 Between-Series Adapters
- 161 Fixed Length Cable Assemblies
- 173 Ultra Miniature Connectors (UMC)
- 181 kwiQMate™ Connectors
- 185 Tools
- 193 Assembly Instructions
- 257 Electronic Hardware
- 274 Index

## Specifications

### Electrical Ratings

**Impedance:** 50 Ohms

**Frequency Range:**

Dummy loads .....	0-2.00 GHz
Flexible cabled connectors .....	0-12.4 GHz
Uncabled receptacles, Right Angle Semi-Rigid cabled connectors and adapters.....	0-18.0 GHz
Straight Semi-Rigid cabled connectors and field replaceable connectors .....	0-26.5 GHz

**VSWR:** (max) (f = GHz)

	Straight Cabled Connectors	Right Angle Cabled Connectors
RG-178.....	1.20 + .025f	1.20 + .03f
RG-316, LMR-100.....	1.15 + .02f	1.15 + .03f
RG-58, LMR-195.....	1.15 + .01f	1.15 + .02f
RG-142.....	1.15 + .01f	1.15 + .02f
LMR-200, LMR-240 .....	1.10 + .03f	1.10 + .06f
RG-405.....	1.07 + .008f	1.18 + .015f
RG-402 (w/contact) .....	1.05 + .008f	1.15 + .015f
RG-402 (w/o contact) .....	1.035 + .005f	

Jack-bulkhead jack adapter and plug-plug adapter .....

Jack-jack adapter and plug-jack adapter .....

Uncabled receptacles, dummy loads.....

Field replaceable (see page 80).....

**Working Voltage:** (VRMS max)†

	Sea Level	70K Feet
RG-178 .....	170	45
RG-316, LMR-100, 195, 200 .....	250	65
RG-58, RG-142, LMR-240, RG-405, uncabled receptacles, RG-402 w/o contact.....	335	85
RG-402 with contact and adapters.....	500	125
Dummy loads .....		N/A

**Dielectric Withstanding Voltage:** (VRMS min at sea level)†

RG-178.....	500
RG-316, LMR-100, 195, 200 .....	750
RG-58, RG-142, LMR-240, RG-405, field replaceable, uncabled receptacles.....	1000
RG-402 with contact and adapters .....	1500
RG-402 w/o contact, dummy loads.....	N/A

**Insulation Resistance:** 5000 megohms min

**Contact Resistance:** (milliohms max)

	Initial	After Environmental
Center contact (straight cabled connectors and uncabled receptacles) .....	3.0*	4.0*
Center contact (right angle cabled connectors and adapters) .....	4.0	6.0
Field replaceable connectors .....	6.0	8.0
Outer contact (all connectors).....	2.0	N/A
Braid to body (gold plated connectors) .....	0.5	N/A
Braid to body (nickel plated connectors).....	5.0	N/A

\*N/A where the cable center conductor is used as a contact

**Corona Level:** (Volts min at 70,000 feet)†

RG-178 .....	125
RG-316, LMR-100, 195, 200 .....	190
RG-58, RG-142, LMR-240, RG-405, uncabled receptacles, RG-402 w/o contact.....	250
RG-402 with contact and adapters.....	375
Dummy loads.....	N/A

## Specifications

**Insertion Loss:** (dB max)

Straight flexible cable connectors and adapters.....	$0.06\sqrt{f(\text{GHz})}$ , tested at 6 GHz
Right angle flexible cable connectors .....	$0.15\sqrt{f(\text{GHz})}$ , tested at 6 GHz
Straight Semi-Rigid cable connectors with contact .....	$0.03\sqrt{f(\text{GHz})}$ , tested at 10 GHz
Right angle Semi-Rigid cable connectors .....	$0.05\sqrt{f(\text{GHz})}$ , tested at 10 GHz
Straight Semi-Rigid cable connectors w/o contact .....	$0.03\sqrt{f(\text{GHz})}$ , tested at 16 GHz
Straight low loss flexible cable connectors .....	$0.06\sqrt{f(\text{GHz})}$ , tested at 1 GHz
Right Angle low loss flexible cable connectors .....	$0.15\sqrt{f(\text{GHz})}$ , tested at 1 GHz

Uncabled receptacles, field replaceable, dummy loads.....

**RF Leakage:** (dB min, tested at 2.5 GHz)

Flexible cable connectors, adapters and RG-402 connectors w/o contact .....	-60 dB
Field replaceable w/o EMI gasket.....	-70 dB
RG-405 connectors and RG-402 connectors with contact, and field replaceable with EMI Gasket.....	-90 dB
Two-way adapters .....	-90 dB
Uncabled receptacles, dummy loads.....	N/A

**RF High Potential Withstanding Voltage:**

(VRMS min, tested at 4 and 7 MHz)†

RG-178.....	335
RG-316, LMR-100, 195, 200.....	500
RG-58, RG-142, LMR-240, RG-405, RG-402 connectors w/o contact, uncabled receptacles .....	670
RG-402 with contact and adapters .....	1000

**Power Rating (Dummy Load):** 0.5 watt @ + 25°C, derated to 0.25 watt @ +125°C

### Mechanical Ratings

<b>Engagement Design:</b>	MIL-STD-348, Series SMA
<b>Engagement/Disengagement Force:</b>	2 lb-in max
<b>Mating Torque:</b>	7 to 10 lb-in
<b>Bulkhead Mounting Nut Torque:</b>	15 lb-in
<b>Coupling Proof Torque:</b>	15 lb-in min
<b>Coupling Nut Retention:</b>	60 lbs min
<b>Contact Retention:</b>	6 lbs min axial force (captivated contacts) 4 oz-in min torque (uncabled receptacles)

Cable Retention: .....	Axial Force* (lbs)	Torque (oz-in)
RG-178.....	10	N/A
RG-316, LMR-100.....	20	N/A
LMR-195, 200 .....	30	N/A
RG-58, LMR-240.....	40	N/A
RG-142.....	45	N/A
RG-405.....	30	16
RG-402.....	60	55

\*Or cable breaking strength whichever is less.

**Durability:** 500 cycles min 100 cycles min for RG-402 connectors w/o contact

### Environmental Specifications

(Meets or Exceeds the Applicable Paragraph of MIL-PRF-39012)

<b>Temperature Range:</b>	- 65°C to + 165°C
<b>Thermal Shock:</b>	MIL-STD-202, Method 107, Condition B (N/A dummy loads)
<b>Corrosion:</b>	MIL-STD-202, Method 101, Condition B (N/A dummy loads)
<b>Shock:</b>	MIL-STD-202, Method 213, Condition I (N/A dummy loads)
<b>Vibration:</b>	MIL-STD-202, Method 204, Condition Dv
<b>Moisture Resistance:</b>	MIL-STD-202, Method 106 (N/A dummy loads)

† Avoid user injury due to misapplication. See safety advisory definitions.

For more information, please contact customer service at (507) 833-8822 or (800) 247-8256 • [www.EmersonConnectivity.com](http://www.EmersonConnectivity.com)

Illustrations are shown in inches (millimeters).



# Specifications

## Material Specifications

- Bodies:** Brass per ASTM B16, gold plated\* per MIL-DTL-45204 .00001" min. or nickel plated per SAE-AMS2423
- Contacts:** Male - brass per ASTM B16, gold plated per MIL-DTL-45204 .00005" min  
Female - beryllium copper per ASTM B196, gold plated per MIL-DTL-45204 .00005" min
- Nut Retention Spring:** Beryllium copper per ASTM B196, Unplated
- Insulators:** PTFE fluorocarbon per ASTM D 1710 and ASTM D 1457 or Tefzel per ASTM D 3159 or PFA 340 per ASTM D 3307
- Expansion Caps:** Brass per ASTM B36, gold plated per MIL-DTL-45204 .00001" min. or nickel plated per SAE-AMS2423
- Crimp Sleeves:** Copper per ASTM B301 or brass per ASTM B16, gold plated per MIL-DTL-45204 .00001" min or nickel plated per SAE-AMS2423
- Mounting Hardware:** Brass (nuts) per ASTM B16 or phosphor bronze (lockwashers), gold plated per MIL-DTL-45204 .00005" min or nickel plated per SAE-AMS2423
- Seal Rings:** Silicone rubber per A-A-59588A
- EMI Gaskets:** Conductive silicone rubber per MIL-G-83528, Type M

\* All gold plated parts include a .00005" min. nickel underplate barrier layer

## Mating Engagement for SMA Series

### NOTES

- ID to meet VSWR, contact resistance and insertion withdrawal forces when mated with a dia. .0355-.0370 pin.
- Gasket is not supplied with brass connectors.

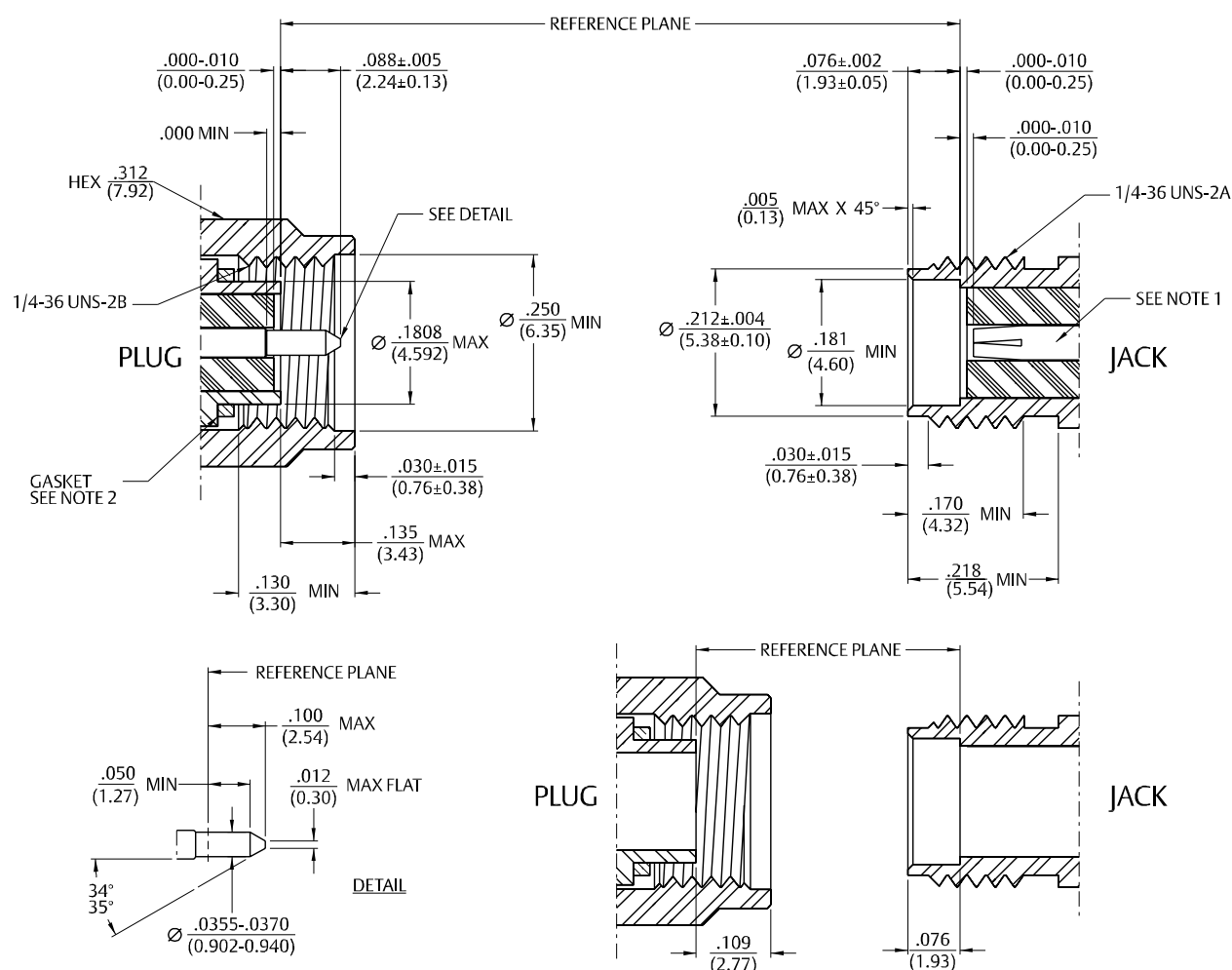

# Quick Connect

The Johnson line of **SMA Quick-Connect Plug** quickly mates to a standard, threaded SMA Jack receptacle allowing rapid test connections to devices utilizing SMA threaded jacks.

SMA electrical performance is not compromised because the connector retains all the benefits of a threaded coaxial coupling. The final connection is a solid metal to metal coupling not relying on spring forces to maintain the coupling. This results in a more reliable connection with less signal leakage and a lower VSWR than most push-on connectors.

Full MIL-PRF-39012 electrical compatibility is obtained with a push and twist motion. The knurled thumbnut requires only one half to one full turn to create a solid electromechanical connection. Rapid disconnect is accomplished with a twist and pull motion.

The SMA Quick-Connect Plug Adapter converts a standard SMA Plug test cable into a Quick-Connect cable. This makes the testing process more efficient by reducing the time and effort required to connect and disconnect the test cable.

Note: Push-on using front of connector, twist back-end coupling nut to secure.

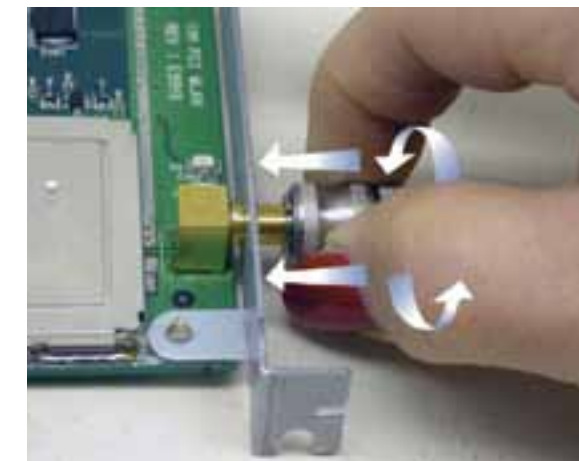

Plugs		
Cable Type	Gold Plated*	"A"
RG-161, 174, 188, 316	142-1403-001	1.249
RG-188 DS, RG-316 DS	142-1404-001	1.249
RG-58, 141, 303	142-1407-001	1.099
RG-55, 142, 223, 400	142-1408-001	1.249

Adapters	
Gold Plated*	
142-1901-821	

\*Nickel plated coupling hardware, gold plated body  
Assembly instructions page 219.

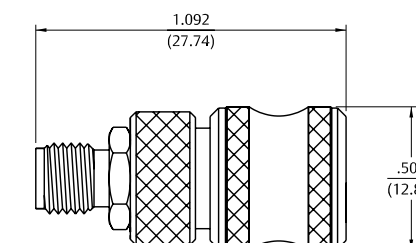
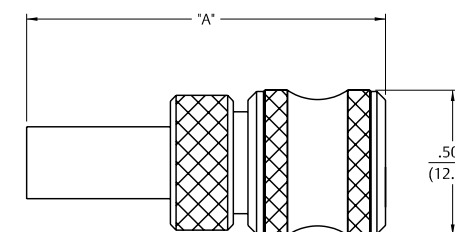

# Semi-Rigid Cable

## Straight Solder Type Plug – with Contact, Captive Nut Thin Wall Connector Interface



Cable Type	Gold Plated	Nickel Plated	Fig.	"A"
RG-405	142-0693-001	142-0693-006	1	.405 (10.29)
RG-402	142-0694-001*	142-0694-006*	2	.440 (11.18)

Assembly instructions page 214.

\*Mating torque 8 lb-in max, coupling proof torque 8 lb-in max.

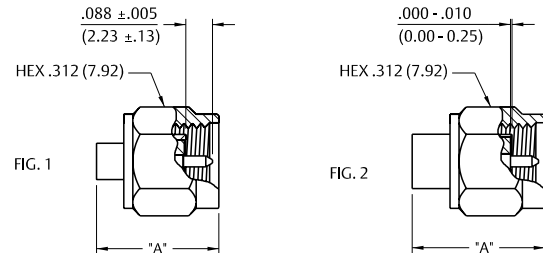

## Straight Solder Type Plug – without Contact, Thread-on Nut



Cable Type	Gold Plated	Nickel Plated
RG-402	142-0694-011	142-0694-016

Assembly instructions page 214.

Center conductor of cable serves as contact.

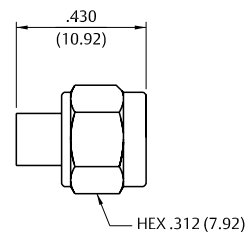

## Right Angle Solder Type Plug (1-piece body)



Cable Type	Gold Plated	Nickel Plated	"A"	"B"
RG-405	142-0693-101	142-0693-106	.336 (8.53)	.253 (6.43)
RG-402	142-0694-101	142-0694-106	.462 (11.73)	.306 (7.77)

Assembly instructions page 213.

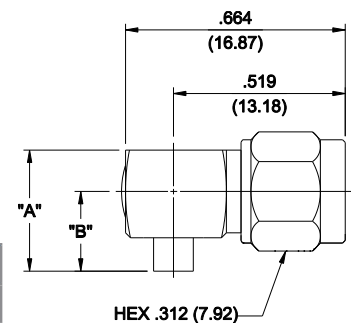

## Straight Solder Type Plug – with Contact, Thread-on Nut



Cable Type	Gold Plated	Nickel Plated	"A"
RG-405	142-0693-051	142-0693-056	.405 (10.29)
RG-402	142-0694-051	142-0694-056	.438 (11.13)

Assembly instructions page 216.

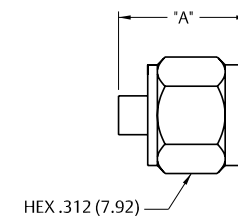

## Straight Solder Type Plug – Short Profile – without Contact, Captive Nut



Cable Type	Gold Plated	Nickel Plated
RG-402	142-0694-031	142-0694-036

Assembly instructions page 215. Center conductor of cable serves as contact.

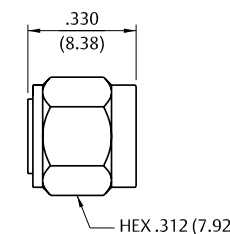

## Straight Solder Type Plug – without Contact, Slide-on Nut



Cable Type	Gold Plated	Nickel Plated
RG-402	142-0694-021	142-0694-026

Assembly instructions page 215.

Center conductor of cable serves as contact.

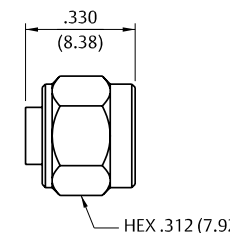

## Straight Solder Type Plug – without Contact, Slide-on Notched Nut



Cable Type	Gold Plated	Nickel Plated
RG-402	142-0694-041	142-0694-046

Assembly instructions page 215. Center conductor of cable serves as contact.

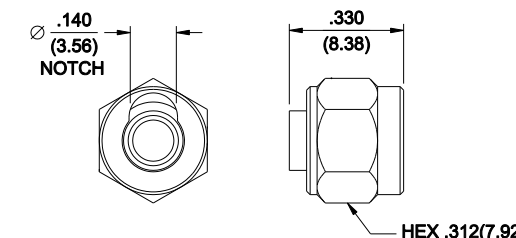

# Semi-Rigid Cable

## Semi-Rigid Cable

### Straight Solder Type Jack

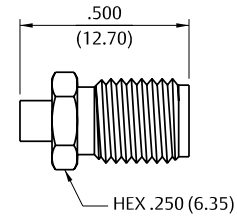

Cable Type	Gold Plated	Nickel Plated
RG-405	142-0593-001	142-0593-006
RG-402	142-0594-001	142-0594-006

Assembly instructions page 214.

### Straight Solder Type Bulkhead Jack with O-Ring

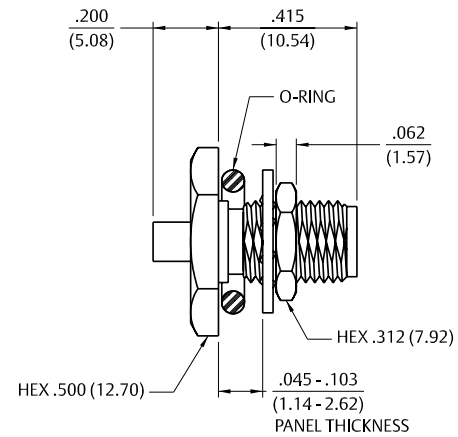

Cable Type	Gold Plated	Nickel Plated
RG-405	142-0593-401	142-0593-406
RG-402	142-0594-401	142-0594-406

Assembly instructions page 214.  
Mounting hole layout figure 1 page 194.

### Straight Solder Type Bulkhead Jack

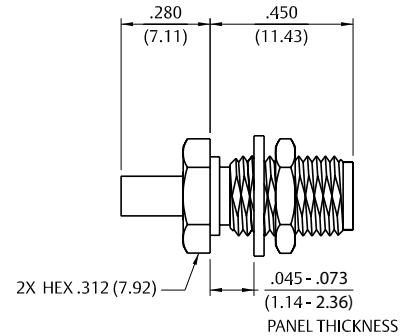

Cable Type	Gold Plated
RG-405	142-0593-411

Assembly instructions page 214.  
Mounting hole layout figure 1 page 194.

## Flexible Cable

53

### Straight Crimp Type Plug (3-piece) – Solder or Crimp Captivated Contact

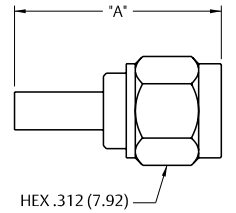

Cable Type	Gold Plated	Nickel Plated	"A"
RG-178, 196	142-0402-011	142-0402-016	.591 (15.01)
RG-161, 174, 188, 316, LMR-100 HPF-100 RF-100	142-0403-011	142-0403-016	.706 (17.93)
RG-188 DS, RG-316 DS	142-0404-011	142-0404-016	.706 (17.93)
RG-58, 141, 303, LMR-195, HPF-195, RF-195	142-0407-011	142-0407-016	.706 (17.93)
RG-55, 142, 223, 400	142-0408-011	142-0408-016	.706 (17.93)
RG-179, 187	142-0433-011	142-0433-016	.706 (17.93)
LMR-200, HPF-200, RF-200	142-0439-001	142-0439-006	.844 (21.44)
LMR-240, HPF-240, RF-240	142-0435-001	142-0435-006	.844 (21.44)

Assembly Instructions: RG-178 page 217. LMR 195, 200 and 240, see page 220.  
Other cable groups, see page 219.

### Right Angle Crimp Type Plug – Captivated Contact

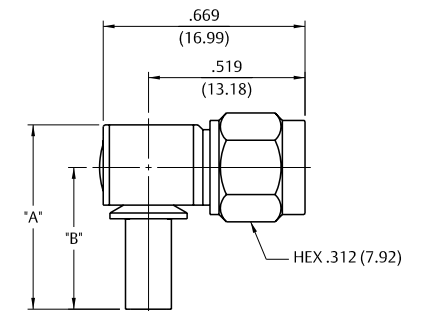

Cable Type	Gold Plated	Nickel Plated	"A"	"B"
RG-178, 196	142-0402-101	142-0402-106	.611 (15.52)	.470 (11.94)
R-161, 174, 188, 316, LMR-100, HPF-100, RF-100	142-0403-101	142-0403-106	.611 (15.52)	.470 (11.94)
RG-188 DS, RG-316 DS	142-0404-101	142-0404-106	.611 (15.52)	.470 (11.94)
LMR-195, HPF-195, RF-195, RG-58, 141, 303	142-0407-101	142-0407-106	.611 (15.52)	.470 (11.94)
RG-55, 142, 223, 400	142-0408-101	142-0408-106	.611 (15.52)	.470 (11.94)
RG-179, 187	142-0433-101	142-0433-106	.611 (15.52)	.470 (11.94)
LMR-200, HPF-200, RF-200	142-0439-101	142-0439-106	.611 (15.52)	.470 (11.94)
LMR-240, HPF-240, RF-240	142-0435-101	142-0435-106	.635 (16.13)	.490 (12.45)

Assembly Instructions: LMR 195, 200 and 240 page 229.  
Other cable groups, see page 224.

# Flexible Cable

## Straight Crimp Type Bulkhead Jack – Captivated Contact



Cable Type	Gold Plated	Nickel Plated
RG-178, 196	142-0302-401	142-0302-406
RG-161, 174, 188, 316	142-0303-401	142-0303-406
RG-188 DS, RG-316 DS	142-0304-401	142-0304-406
RG-58, 141, 303	142-0307-401	142-0307-406
RG-55, 142, 223, 400	142-0308-401	142-0308-406

Assembly instructions page 225.  
Mounting hole layout figure 1 page 194.

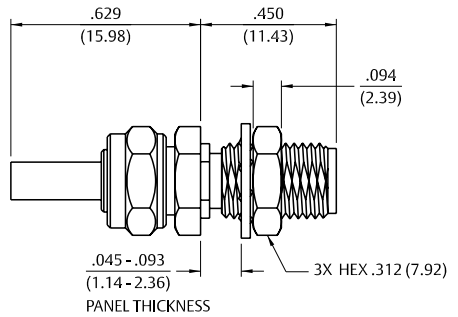

## Straight Crimp Type Bulkhead Jack (3-piece) – Solder or Crimp Captivated Contact



Cable Type	Gold Plated	Nickel Plated	"A"
RG-178, 196	142-0302-431	142-0302-436	.285 (7.24)
RG-161, RG-16, 174, 188, 316, LMR-100 HPF-100 RF-100	142-0303-411	142-0303-416	.385 (9.78)
RG-188 DS, RG-316 DS	142-0304-411	142-0304-416	.385 (9.78)
RG-58, 141, 303, LMR-195, HPF-195, RF-195	142-0307-411	142-0307-416	.385 (9.78)
RG-55, 142, 223, 400	142-0308-411	142-0308-416	.385 (9.78)
RG-179, 187	142-0333-411	142-0333-416	.385 (9.78)
LMR-200, HPF-200, RF-200	142-0339-401	142-0339-406	.545 (13.84)
LMR-240, HPF-240, RF-240	142-0335-401	142-0335-406	.545 (13.84)

Assembly Instructions: RG-178 page 217. LMR 195, 200 and 240, see page 220.  
Other cable groups, see page 219. Mounting hole layout figure 1 page 194.

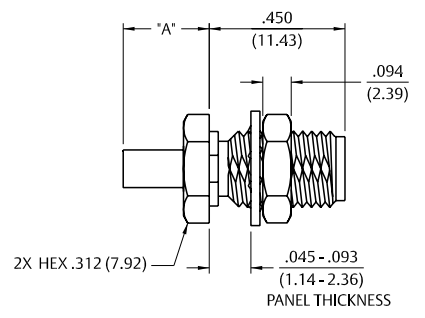

## Straight Crimp Type Jack (3-piece) – Solder or Crimp Captivated Contact



Cable Type	Gold Plated	Nickel Plated	"A"
RG-178, 196	142-0302-011	142-0302-016	.651 (16.54)
RG-161, 174, 188, 316	142-0303-011	142-0303-016	.756 (19.20)
RG-188 DS, RG-316 DS	142-0304-011	142-0304-016	.756 (19.20)
RG-58, 141, 303	142-0307-011	142-0307-016	.756 (19.20)
RG-55, 142, 223, 400	142-0308-011	142-0308-016	.756 (19.20)

Assembly Instructions: RG-178 page 217. LMR 195, 200 and 240, see page 220.  
Other cable groups, see page 219. Mounting hole layout figure 1 page 194.

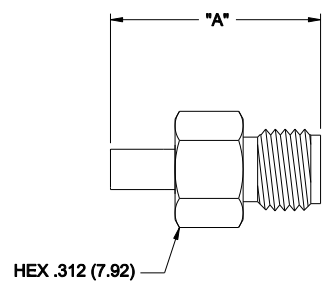

# Flexible Cable

## Straight Clamp Type Plug – Captivated Contact



Cable Type	Gold Plated	Nickel Plated	"A"
RG-178, 196	142-0202-011	142-0202-016	.816 (20.73)
RG-161, 174, 188, 316	142-0203-011	142-0203-016	.816 (20.73)
RG-58, 141, 303, 55, 142, 223, 400	142-0207-011	142-0207-016	.895 (22.73)

Assembly instructions page 230.  
Mounting hole layout figure 1 page 194.

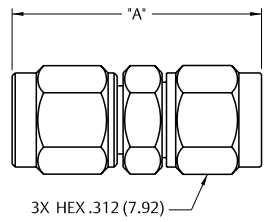

## Right Angle Clamp Type Plug – Captivated Contact



Cable Type	Gold Plated	Nickel Plated	"A"	"B"
RG-178 196	142-0202-101	142-0202-106	.569 (14.45)	.428 (10.81)
RG-161 174, 188, 316	142-0203-101	142-0203-106	.574 (14.58)	.433 (11.00)
RG-58, 141, 303, 55, 142, 223, 400	142-0207-101	142-0207-106	.686 (17.42)	.545 (13.84)

Assembly instructions page 231.  
Mounting hole layout figure 1 page 194.

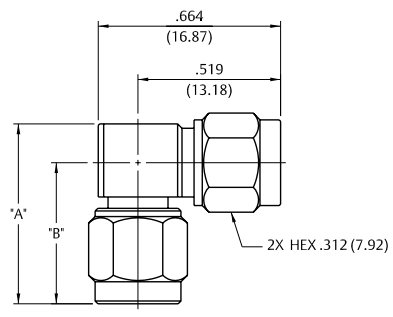

## Straight Clamp Type Bulkhead Jack – Captivated Contact



Cable Type	Gold Plated	Nickel Plated	"A"
RG-178, 196	142-0102-401	142-0102-406	.452 (11.48)
RG-161, 174, 188, 316	142-0103-401	142-0103-406	.487 (12.37)
RG-58, 141, 303, 55, 142, 223, 400	142-0107-401	142-0107-406	.531 (13.49)

Assembly instructions page 230.

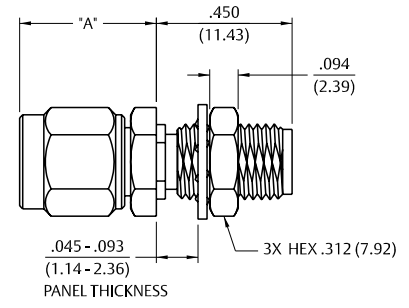

## Rear Mount Bulkhead Plug – Antenna Connector



Cable Type	Gold Plated
RG-178, .047 Semi-Rigid	142-0801-421 *

\* With Nickel mounting nut. Assembly instructions page 216.  
Mates with SMA Jack Antenna Interface.

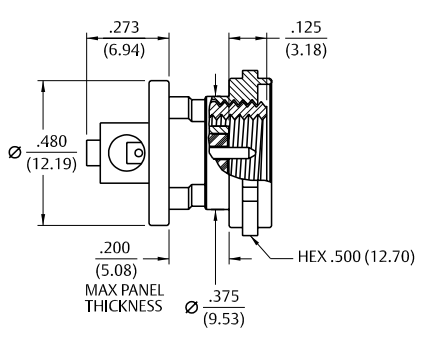

For more information, please contact customer service at (507) 833-8822 or (800) 247-8256 • www.EmersonConnectivity.com  
Illustrations are shown in inches (millimeters).

# PC Mount

## Straight Plug Receptacle



Gold Plated	Nickel Plated
142-0801-201	142-0801-206

Mounting hole layout figure 2 page 194.

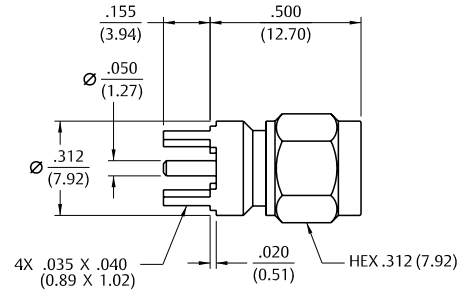

## Right Angle Plug Receptacle



Gold Plated	Nickel Plated
142-0801-301	142-0801-306

Mounting hole layout figure 2 page 194.

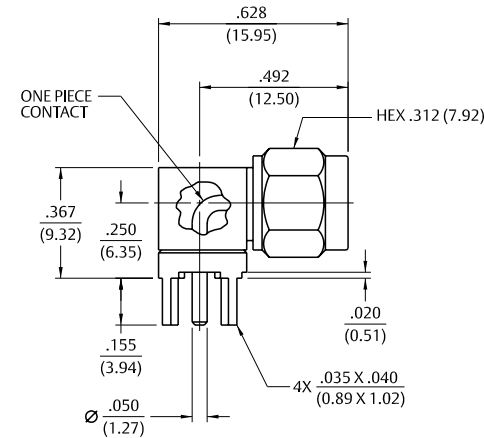

## Straight Jack Receptacle



Gold Plated	Nickel Plated	"A"
142-0701-201	142-0701-206	.155 (3.94)
142-0701-231	142-0701-236	.110 (2.79)

Mounting hole layout figure 2 page 194.

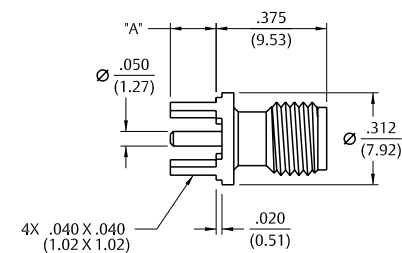

## Straight Bulkhead Jack Receptacle



Gold Plated	Nickel Plated	"A"	"B"
142-0701-421	142-0701-426	.700 (17.78)	.450 (11.43)
142-0701-491	142-0701-496	.065 (1.65)	.755 (19.18)

Mounting hole layout figure 2 page 194.

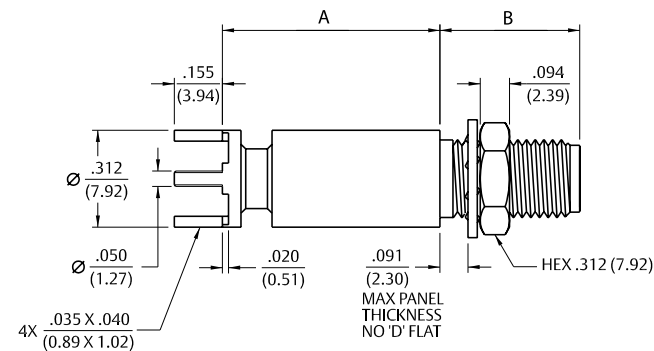

# PC Mount

## Straight Jack Receptacle – Surface Mount



Gold Plated	Packaging
142-0711-201	Stock
142-0711-202	Tape and Reel 500 pcs/reel

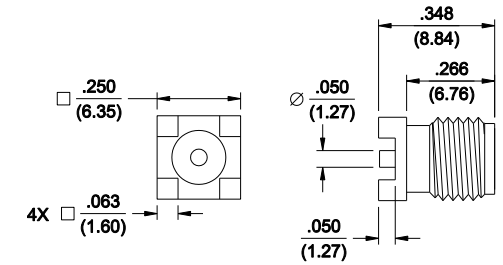

## Right Angle Jack Receptacle



Gold Plated	Nickel Plated
142-0701-301	142-0701-306

Recommended Land Pattern figure 2 page 194.

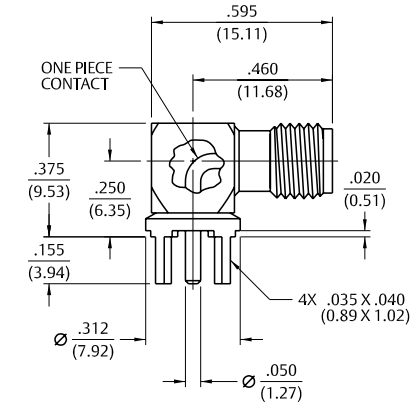

## Right Angle Jack Receptacle – Surface Mount



Gold Plated	Packaging
142-0711-301	Stock
142-0711-302	Tape and Reel 425 pcs/reel

Recommended Land Pattern figure 7 page 194.

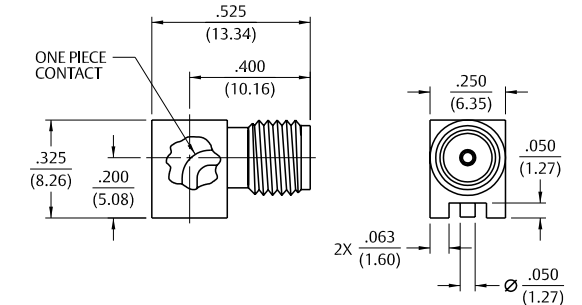

## Right Angle Bulkhead Jack Receptacle



Gold Plated	Nickel Plated	"A"
142-0701-501	142-0701-506	.155 (3.94)
142-0701-551	142-0701-556	.110 (2.79)

Mounting hole layout figure 1 and 2 page 194.

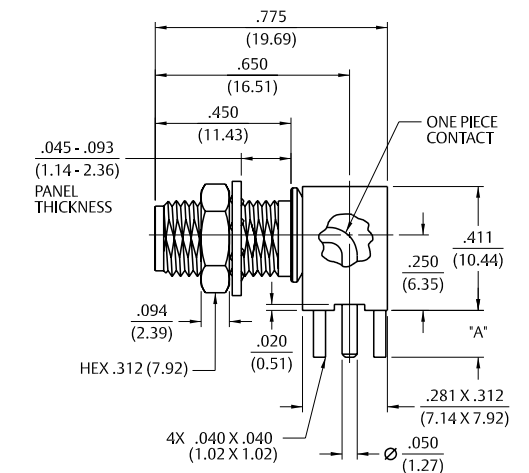

For more information, please contact customer service at (507) 833-8822 or (800) 247-8256 • [www.EmersonConnectivity.com](http://www.EmersonConnectivity.com)

Illustrations are shown in inches (millimeters).

# PC Mount

The **End Launch** connector is attached to the circuit board by inserting the board edge between the legs and soldering the legs and center conductor to pads on the board. For optimum high frequency performance, the connector to circuit board transition must be adjusted for low VSWR. To compensate for the transition from coax to microstrip, trace widths "A" and "B" must be adjusted based on circuit board thickness. When properly adjusted, this technique yields a low VSWR over a wide bandwidth.

The tabulated dimensions "A", "B", "C", "D", and "E" were determined experimentally to achieve low VSWR (typically less than 1.5 up to 18 GHz). The circuit board used connectors for these tests was double-sided FR 4 with 1 oz. copper on both sides. The copper was left on the bottom of the board to create a ground plane for the 50 Ohm microstrip structure. While not all inclusive, these dimensions are given as reference information for selected SMA End Launch connectors. Further adjustments may be necessary depending upon the application. All dimensions are in inches.

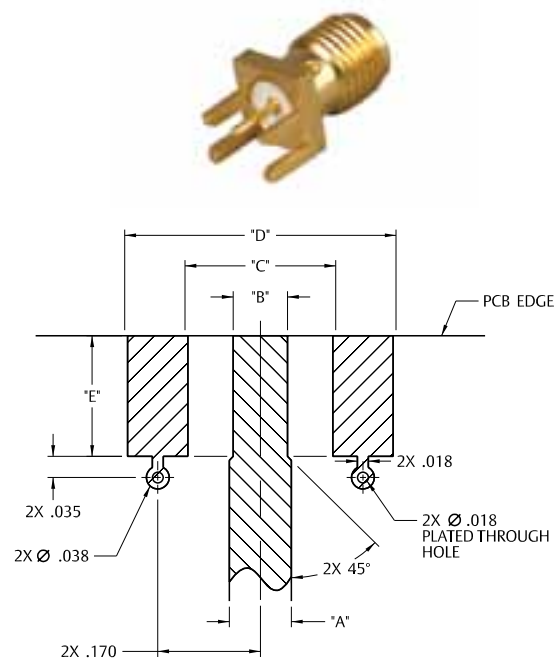

Part No.	Base Width	Board Thickness	"A"	"B"	"C"	"D"	"E"
142-0701-801/806	.375	.062	.103	.090	.250	.440	.200
142-0701-851/858	.375	.062	.103	.090	.250	.440	.200
142-0701-871/876	.375	.062	.103	.090	.250	.440	.200
142-0711-821/826	.250	.062	.103	.070	.170	.380	.165
142-0711-871/876	.375	.047	.083	.075	.250	.440	.200
142-0711-881/886	.375	.047	.083	.075	.250	.440	.200
142-0701-881/886	.375	.031	.050	.045	.250	.440	.200

Tabulated Dimensions "A", "B", "C", and "D" are symmetrical about the center line.

## End Launch Plug Receptacle – Round Contact

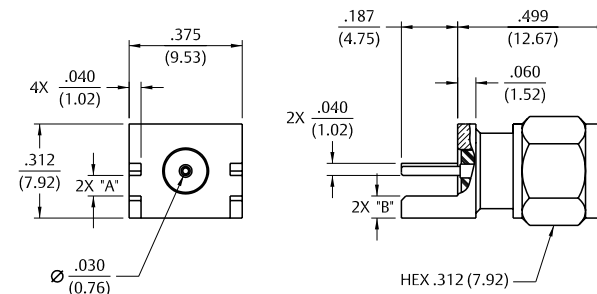

Gold Plated	Nickel Plated	Board Thickness	"A"	"B"
142-0801-801	142-0801-806	.062 (1.57)	.068 (1.73)	.073 (1.85)
142-0801-821	142-0801-826	.042 (1.07)	.048 (1.22)	.093 (2.36)

## End Launch Plug Receptacle – Tab Contact

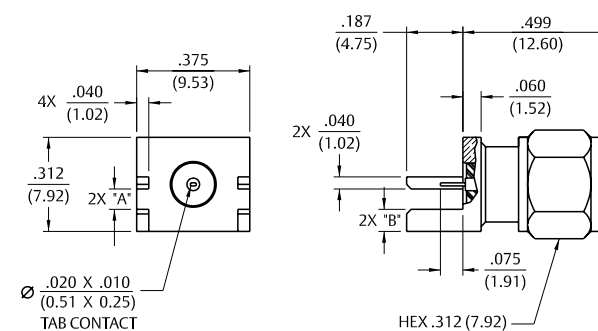

Gold Plated	Nickel Plated	Board Thickness	"A"	"B"
142-0801-811	142-0801-816	.062 (1.57)	.068 (1.73)	.083 (2.11)
142-0801-831	142-0801-836	.042 (1.07)	.048 (1.22)	.103 (2.62)

## End Launch Plug Receptacle – Round Contact

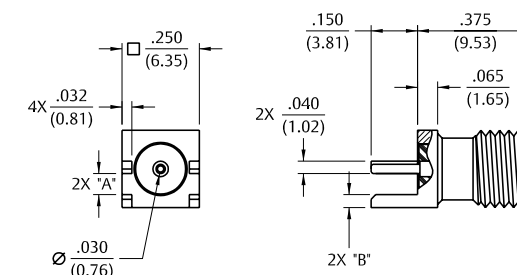

Gold Plated	Nickel Plated	Board Thickness	"A"	"B"
142-0711-821	142-0711-826	.062 (1.57)	.068 (1.73)	.042 (1.07)
142-0711-841	142-0711-846	.042 (1.07)	.048 (1.22)	.062 (1.57)

Coupling proof torque 8 lb-ins maximum without support .083 (2.11) wrench.

# PC Mount

## End Launch Jack Receptacle – Round Contact

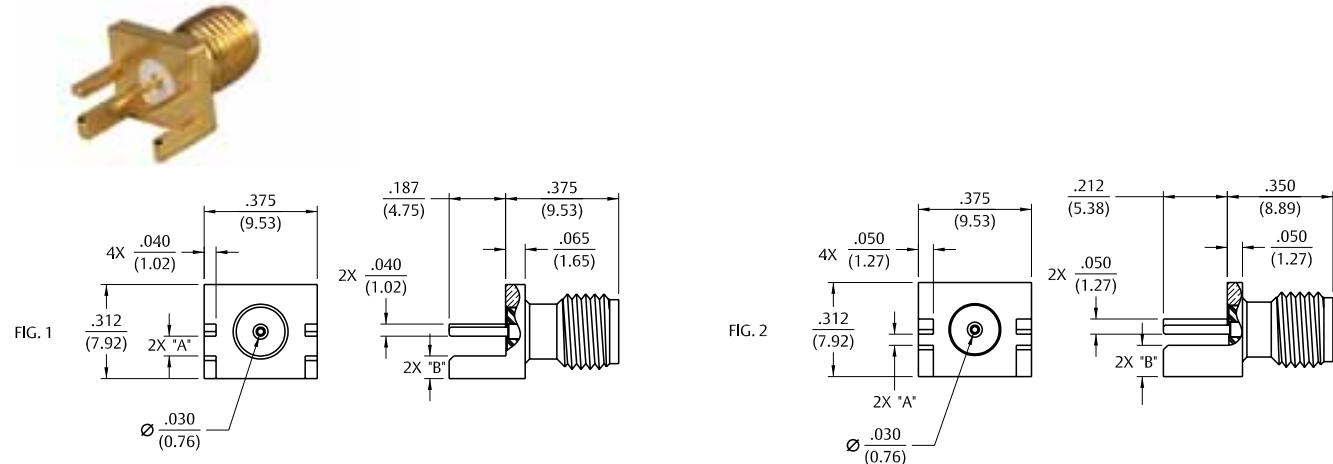

Gold Plated	Nickel Plated	Board Thickness	"A"	"B"	Figure
142-0701-801	142-0701-806	.062 (1.57)	.068 (1.73)	.073 (1.85)	1
142-0701-831	142-0701-836	.042 (1.07)	.048 (1.22)	.093 (2.36)	1
142-0701-881	142-0701-886	.031 (0.79)	.037 (0.94)	.104 (2.64)	2
142-0711-871	142-0711-876	.047 (1.19)	.053 (1.35)	.088 (2.24)	1

## End Launch Jack Receptacle – Tab Contact

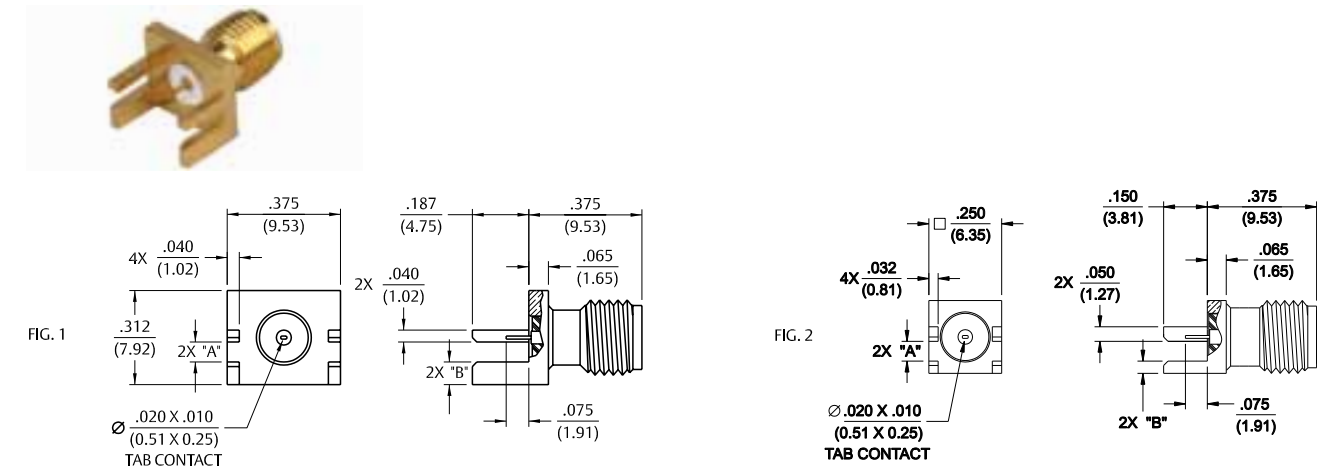

Gold Plated	Nickel Plated	Board Thickness	"A"	"B"	Figure
142-0701-851	142-0701-856	.062 (1.57)	.068 (1.73)	.083 (2.11)	1
142-0701-841	142-0701-846	.042 (1.07)	.048 (1.22)	.103 (2.62)	1
142-0711-881	142-0711-886	.047 (1.19)	.053 (1.35)	.098 (2.24)	1
142-0721-811	142-0721-816	.025 (0.64)	.030 (0.76)	.121 (3.07)	1
142-0721-861	142-0721-866	.032 (0.81)	.037 (0.94)	.083 (2.11)	2

# PC Mount

## End Launch Bulkhead Jack Receptacle – Round Contact

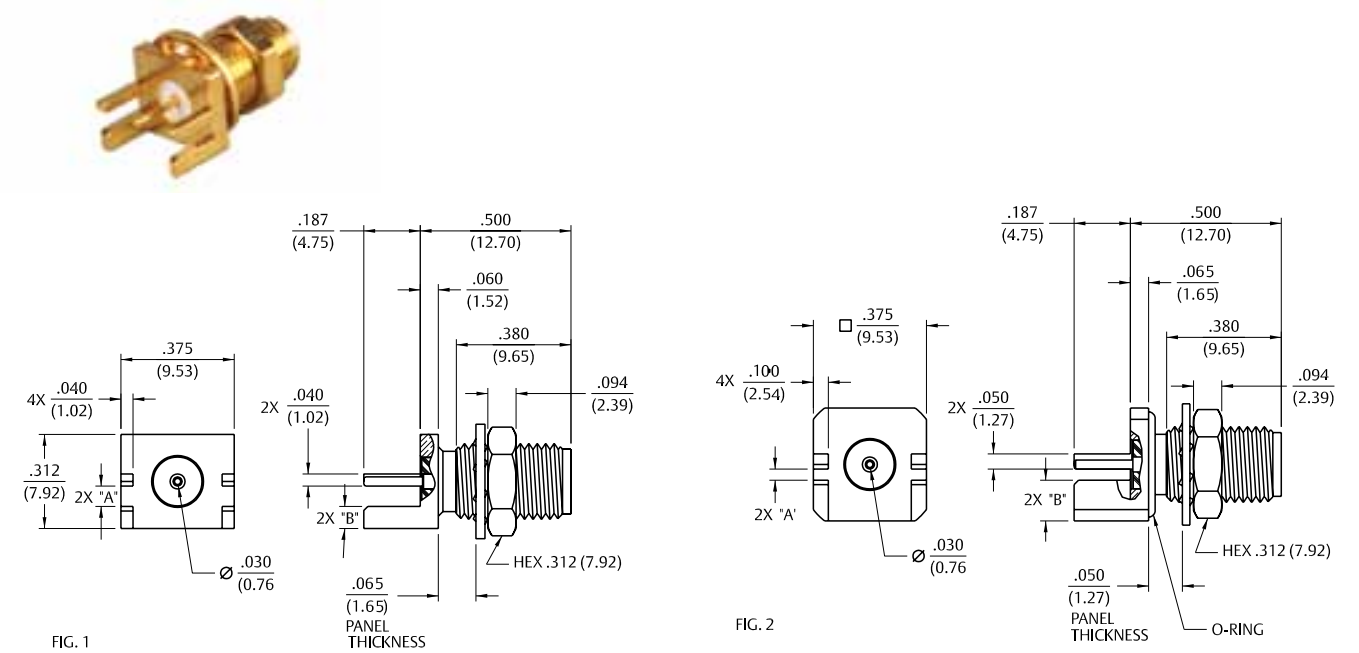

Gold Plated	Nickel Plated	Board Thickness	"A"	"B"	"O" Ring	Figure
142-0701-871	142-0701-876	.062 (1.57)	.068 (1.73)	.073 (1.85)	No	1
142-0721-871	142-0721-876	.074 (1.88)	.080 (2.03)	.061 (1.55)	No	1
142-0721-841	142-0721-846	.069 (1.75)	.075 (1.91)	.066 (1.68)	No	1
142-0731-861	142-0731-866	.031 (0.79)	.037 (0.94)	.135 (3.43)	Yes	2

## End Launch Bulkhead Jack Receptacle – Round Contact

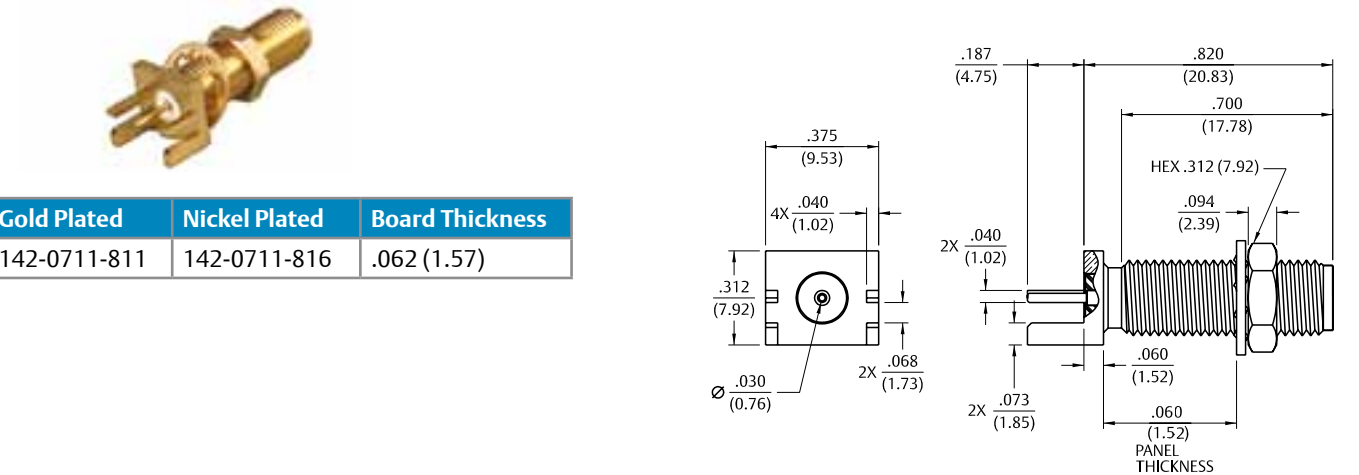

Gold Plated	Nickel Plated	Board Thickness
142-0711-811	142-0711-816	.062 (1.57)

## Bulkhead Mount

### End Launch Jack Receptacle – Surface Mount



Gold Plated	Packaging
142-0721-881	Stock
142-0721-882	Tape and Reel 475 pcs/reel

Recommended land pattern figure 22 page 195.

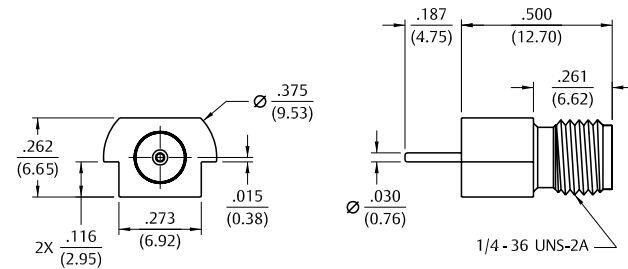

### Front Mount Bulkhead Jack Receptacle



Gold Plated	Nickel Plated
142-0701-411	142-0701-416

Mounting hole layout figure 1 page 194.

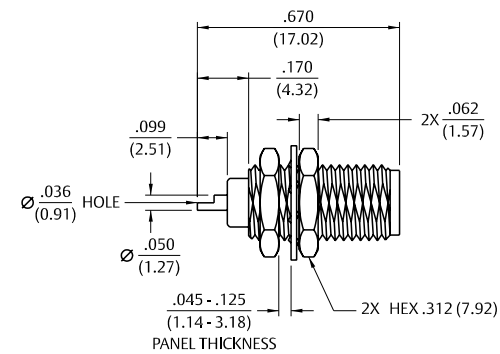

### Rear Mount Bulkhead Jack Receptacle



Gold Plated	Nickel Plated
142-0701-401	142-0701-406

Mounting hole layout figure 1 page 194.

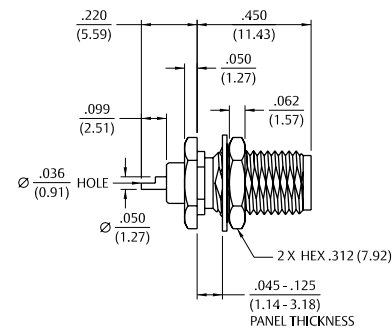

### Right Angle Bulkhead Mount Jack Receptacle



Gold Plated	Nickel Plated
142-0701-531	142-0701-536

Mounting hole layout figure 1 page 194.

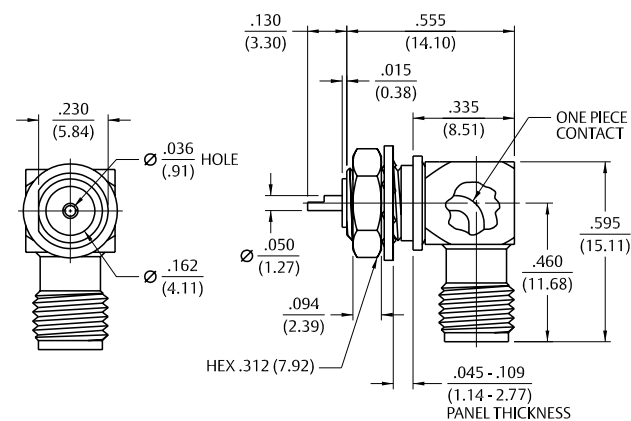

## Self-Fixture End Launch

63

### Gold Plated, Round Contact



Part No.	Board Thickness
142-0791-801	.062 (1.57)

Assembly instructions page 227.

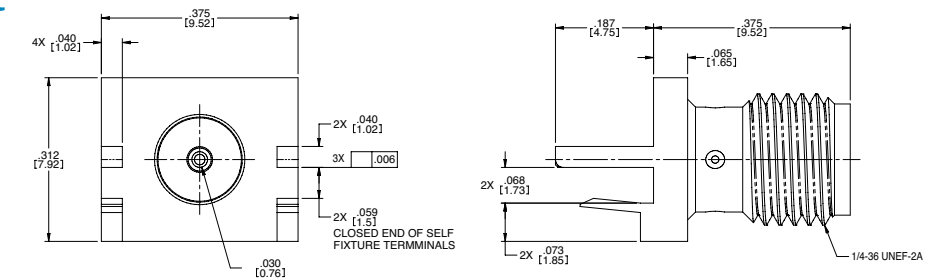

### Gold Plated, Tab Contact



Part No.	Board Thickness	"A"	"B"	"C"
142-0791-811	.042 (1.07)	.048 (1.22)	.103 (2.62)	.039 (0.99)
142-0791-821	.062 (1.57)	.068 (1.73)	.083 (2.11)	.059 (1.50)

Assembly instructions page 227.

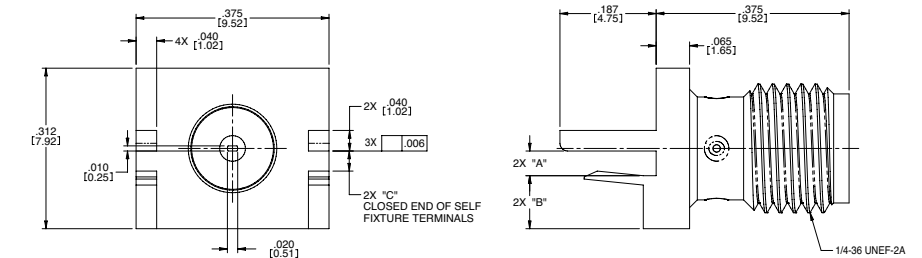

### Gold Plated, Round Contact – High Frequency



Part No.	Frequency Range	Board Thickness	"A"	"B"
142-1701-821	0-26.5 GHz	.062 (1.57)	.068	.059
142-1701-831	0-26.5 GHz	.059 (1.49)	.063	.054

Assembly instructions page 227.

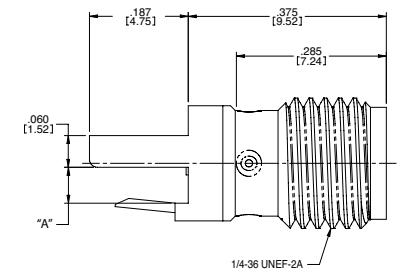
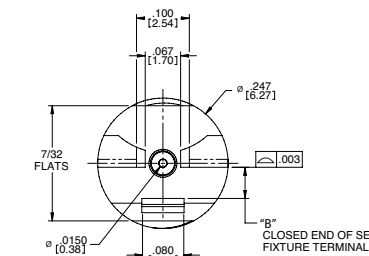



## Spark Plugs

## Jack Receptacle – Thread Mount Field Replaceable

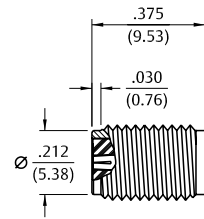

Gold Plated	Nickel Plated	Accepts Pin Size
142-1731-001	142-1731-006	.020 (0.51)
142-1731-011	142-1731-016	.036 (0.91)

Mounting hole layout figure 19 page 195.

## Jack Receptacle – Thread Mount Extended Dielectric (Non-Hermetic)

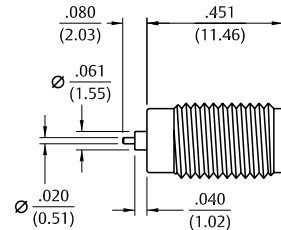

Gold Plated	Nickel Plated
142-1731-021	142-1731-026

Mounting hole layout for 142-1731-021 figure 19 page 195.  
Mounting hole layout for 142-1731-026 figure 18 page 195.

## Jack Receptacle – Thread Mount with Hardware Extended Dielectric Bulkhead

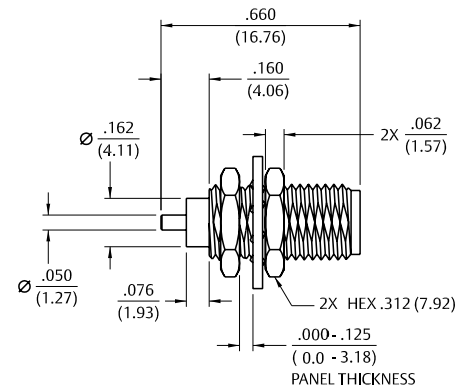

Gold Plated	Nickel Plated
142-1731-031	142-1731-036

Mounting hole layout for 142-1731-031 figure 18 page 195.  
Mounting hole layout for 142-1731-036 figure 1 page 194.

## Spark Plugs

65

## Jack Receptacle – Knurl Mount\* Tab Contact



Gold Plated	Nickel Plated
142-1721-001	142-1721-006

\* Not intended for use in materials harder than Rockwell B82.  
Assembly tool 140-0000-954 page 188.  
Mounting hole layout figure 17 page 195.

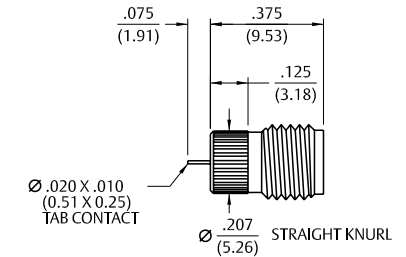

## Jack Receptacle – Knurl Mount\* Round Contact



Gold Plated	Nickel Plated
142-1721-011	142-1721-016

\* Not intended for use in materials harder than Rockwell B82.  
Assembly tool 140-0000-954 page 188.  
Mounting hole layout figure 17 page 195.

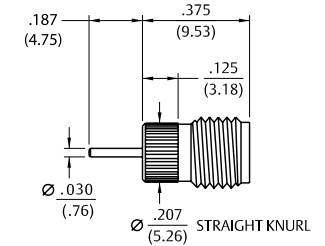

# Spark Plugs

## Jack Receptacle – Knurl Mount \* Round Contact

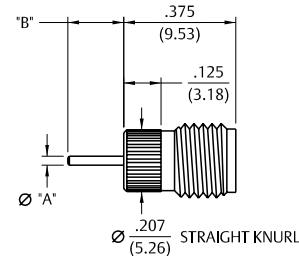

Gold Plated	Nickel Plated	"A"	"B"
142-1721-011	142-1721-016	.030 (0.76)	.187 (3.18)
142-1721-021	142-1721-026	.050 (1.24)	.190 (4.83)

\* Not intended for use in materials harder than Rockwell B82. Mounting hole layout figure 17 page 195.

## Jack Receptacle – Knurl Mount \* Solder Cup Contact

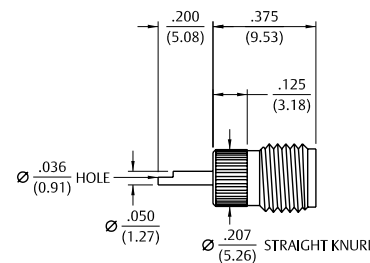

Gold Plated	Nickel Plated
142-0701-481	142-0701-486

\* Not intended for use in materials harder than Rockwell B82. Mounting hole layout figure 17 page 195.

## Jack Receptacle – Knurl Mount \* Extended Dielectric

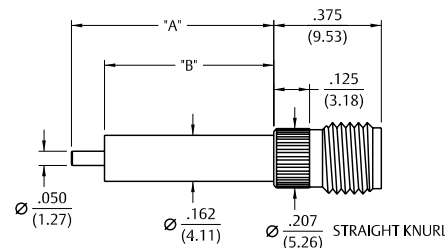

Gold Plated	Nickel Plated	"A"	"B"
142-1721-031	142-1721-036	.190 (4.83)	.095 (2.41)
142-1721-041	142-1721-046	.240 (6.10)	.180 (4.57)
142-1721-051	142-1721-056	.705 (17.91)	.590 (14.99)

\* Not intended for use in materials harder than Rockwell B82. Mounting hole layout figure 17 page 195.

## 2-Hole Flange Mount Jack Receptacle – Flush Dielectric



Gold Plated	Nickel Plated
142-0701-621	142-0701-626

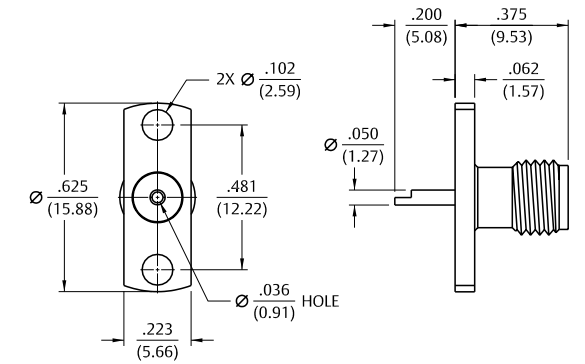

## 4-Hole Flange Mount Jack Receptacle – Flush Dielectric



Gold Plated	Nickel Plated
142-0701-631	142-0701-636

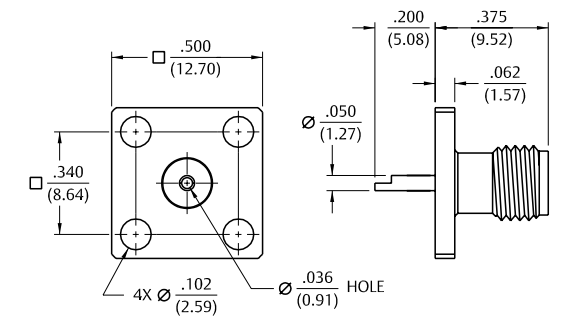

## 2-Hole Flange Mount Jack Receptacle – Extended Dielectric



Gold Plated	Nickel Plated	"A"	"B"
142-1701-131	142-1701-136	.705 (17.91)	.590 (14.99)
142-1701-031	142-1701-036	.240 (6.10)	.180 (4.57)

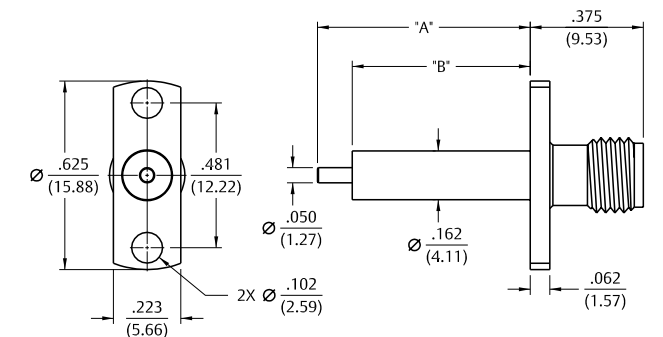

# Panel Mount

## 4-Hole Flange Mount Jack Receptacle – Extended Dielectric

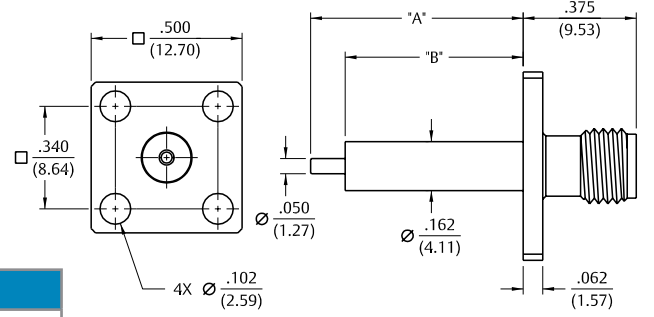

Gold Plated	Nickel Plated	"A"	"B"
142-1701-121	142-1701-126	.705 (17.91)	.590 (14.99)
142-1701-041	142-1701-046	.190 (4.83)	.095 (2.41)

## 4-Hole Flange Mount Jack Receptacle – Extended Dielectric

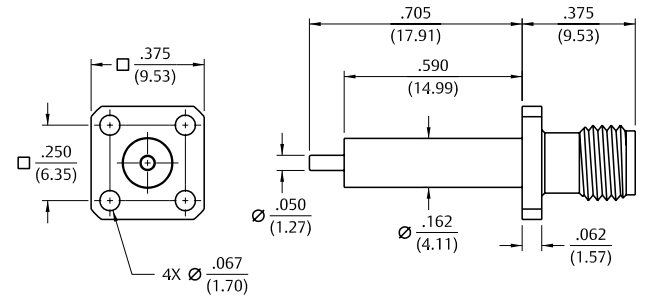

Gold Plated	Nickel Plated
142-1701-011	142-1701-016

## 2-Hole Flange Mount Jack Receptacle – Extended Dielectric

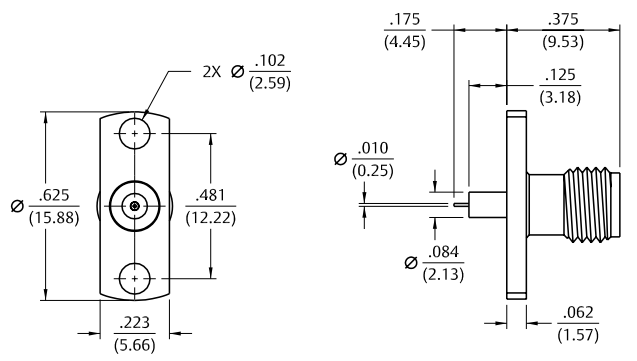

Gold Plated	Nickel Plated
142-1701-201	142-1701-206

# Panel Mount

## 4-Hole Flange Mount Jack Receptacle – Extended Dielectric

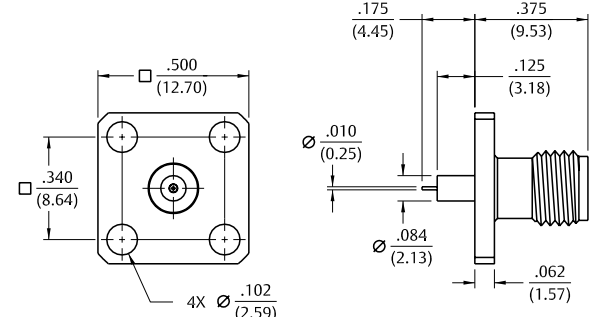

Gold Plated	Nickel Plated
142-1701-191	142-1701-196

## 4-Hole Right Angle Flange Mount Jack Receptacle – Extended Dielectric

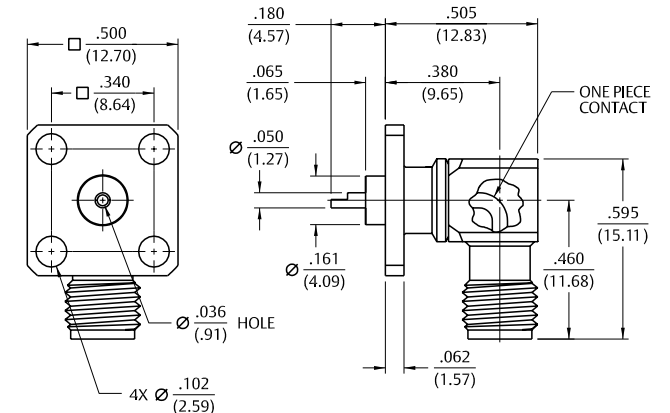

Gold Plated	Nickel Plated
142-0701-701	142-0701-706

## 4-Hole Right Angle Flange Mount Jack Receptacle – Extended Dielectric

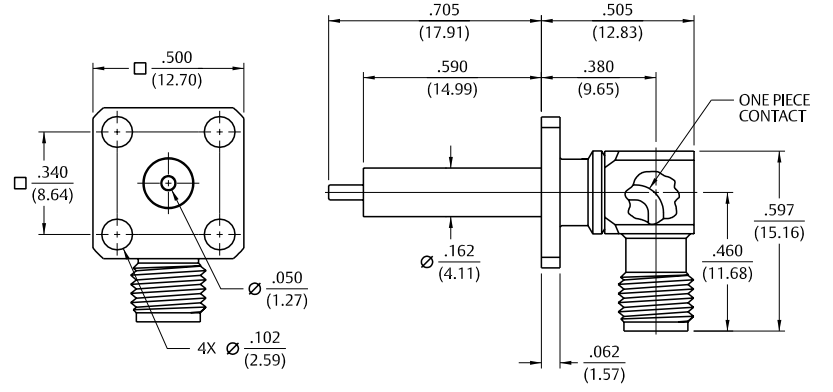

Gold Plated	Nickel Plated
142-1711-001	142-1711-006

## Panel Mount

## Field Replaceable

## 2-Hole Right Angle Flange Mount Jack Receptacle – Extended Dielectric 90° Orientation

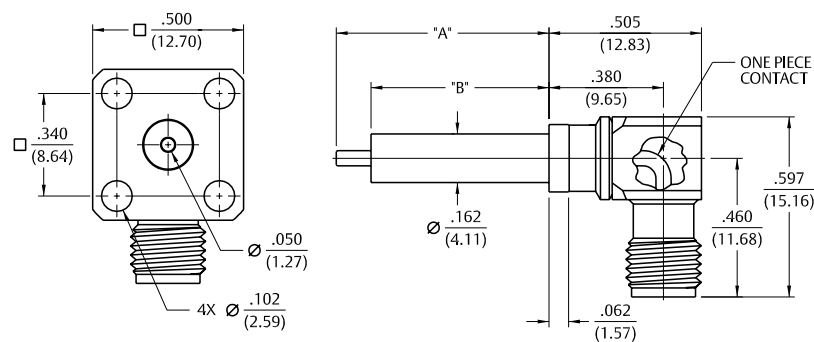

Gold Plated	Nickel Plated	"A"	"B"
142-1711-011	142-1711-016	.705 (17.91)	.590 (14.99)
142-1711-061	142-1711-066	.195 (4.95)	.130 (3.30)

## 2-Hole Right Angle Flange Mount Jack Receptacle – Extended Dielectric +45° Orientation

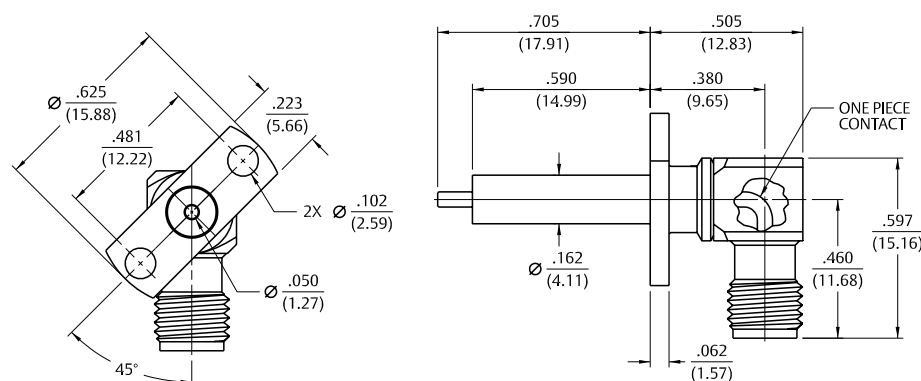

Gold Plated	Nickel Plated
142-1711-021	142-1711-026

## 2-Hole Right Angle Flange Mount Jack Receptacle – Extended Dielectric -45° Orientation

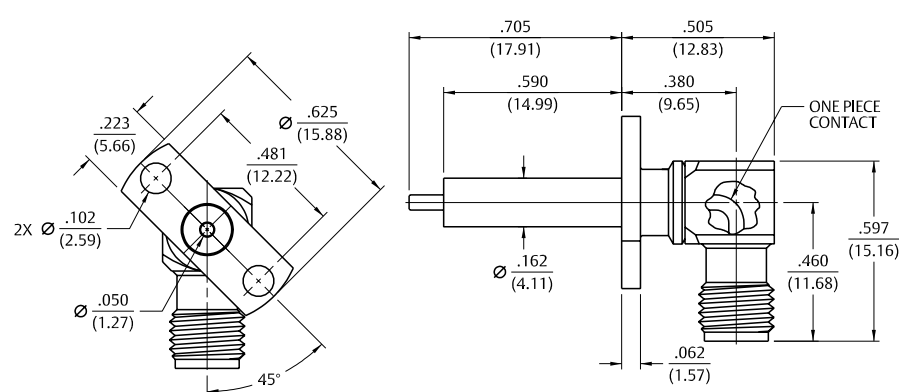

Gold Plated	Nickel Plated
142-1711-031	142-1711-036

## Application Notes

The field replaceable style of connector is known by many names in the industry, such as MIC launcher, hermetic seal launcher, spark plug launcher, etc. Some types, such as those known as “spark plugs,” have the hermetic seal incorporated into the connector. These types require special welding to install and can not be replaced without destroying the hermeticity of the circuit housing. True field replaceable connectors, such as the Johnson line, are easy to install and replace. Because the hermetic seal is not incorporated into the connector design, the connector can be removed and replaced without destroying the hermetic seal or the hermeticity of the circuit housing.

All of the above-mentioned connector types perform the same basic function—creating a transition from microstrip circuitry to a coaxial transmission line. Whenever possible, the hermetic seal pin diameter should be chosen as close as possible to the microstrip trace width. For optimum electrical performance, the transition from the hermetic seal to the microstrip trace must be properly compensated which involves adjusting the microstrip trace width to minimize any impedance discontinuities found in the transition area.

The plot shown below is representative of the typical return loss of a Johnson SMA field replaceable connector. To produce the data shown below, a test fixture is created using the appropriate Johnson hermetic seal. The fixture consists of a suitably thick spacer plate with the hermetic seal mounted flush to both surfaces. Two connectors are mounted back to back around the fixture and the VSWR of this test assembly is measured. The return loss data shown is equivalent to the square root of the measured VSWR of the test assembly. Since the connectors tested are of identical design, it can be stated with fair accuracy that the data shown represents the response of a single field replaceable connector and its transition to the hermetic seal.

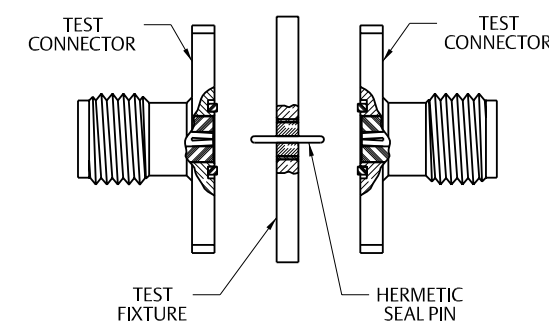

Although we do not publish a VSWR specification for field replaceable connectors, typical connector VSWR can be expected to be better than  $1.1 + .01f$  ( $f = \text{GHz}$ ). A VSWR specification is not stated because an industry standardized method for testing field replaceable connectors does not exist. The actual performance of the connector is dependent upon the application for the following reasons:

1. The choice of hermetic seal to be used by the customer is not specified by the connector manufacturer. Hermetic seals produced by different manufacturers will not have the same electrical characteristics. For optimum electrical performance, we recommend the use of our standard 142-1000-001, 002, 003 and 004 hermetic seals for pin diameters of .012 (.30), .015 (.38), .018 (0.46) and .020 (0.51). Custom hermetic seal configurations can be quoted.
2. It is recommended that the hermetic seal be mounted flush with the circuit housing. Tolerance variations between the hermetic seal and machined housing do not always guarantee an optimum transition to the connector. Emerson does not recommend the addition of a counter bore in the circuit housing to accommodate solder washers as solder voids will cause electrical discontinuities.
3. As stated above, the transition between the hermetic seal pin and the microstrip trace will affect electrical performance. Several different methods of hermetic seal mounting and seal pin to microstrip trace attachment are used in the industry. We cannot recommend one method over the other as this is dependent upon the customer's application.

“As always, quotes for non-standard field replaceable connectors and/or hermetic seals are welcome.”

For more information, please contact customer service at (507) 833-8822 or (800) 247-8256 • [www.EmersonConnectivity.com](http://www.EmersonConnectivity.com)

Illustrations are shown in inches (millimeters).

## Field Replaceable Panel Mount

## 2-Hole Flange Mount Jack Receptacle – with EMI Gasket

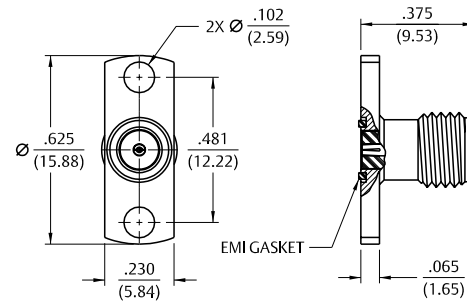

Accepts Pin Size	Gold Plated	Nickel Plated
.012 (0.30)	142-1701-601	142-1701-606
.015 (0.38)	142-1701-611	142-1701-616
.018 (0.46)	142-1701-621	142-1701-626

## 2-Hole Flange Mount Jack Receptacle – without EMI Gasket

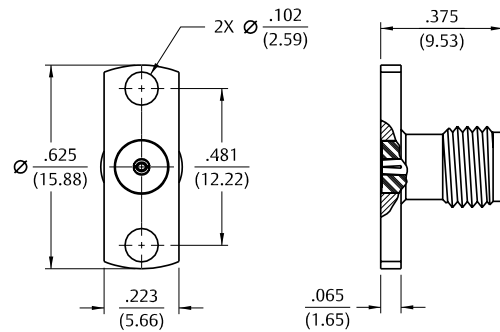

Accepts Pin Size	Gold Plated	Nickel Plated
.020 (0.51)	142-1701-631	142-1701-636
.036 (0.91)	142-1701-641	142-1701-646

## 4-Hole Flange Mount Jack Receptacle – with EMI Gasket

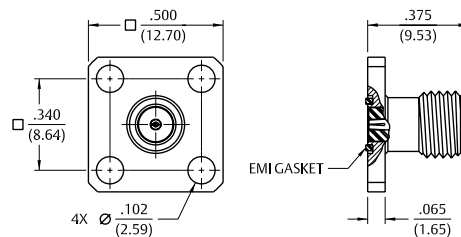

Accepts Pin Size	Gold Plated	Nickel Plated
.012 (0.30)	142-1701-501	142-1701-506
.015 (0.38)	142-1701-511	142-1701-516
.018 (0.46)	142-1701-521	142-1701-526

## 4-Hole Flange Mount Jack Receptacle – without EMI Gasket

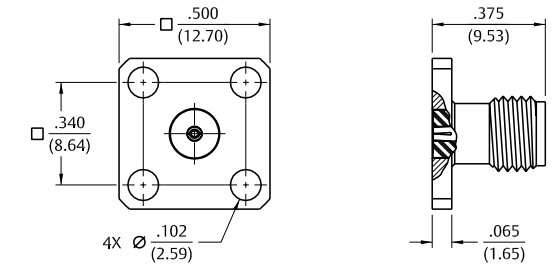

Accepts Pin Size	Gold Plated	Nickel Plated
.020 (0.51)	142-1701-531	142-1701-536
.036 (0.91)	142-1701-541	142-1701-546

## 4-Hole Flange Mount Jack Receptacle – with EMI Gasket

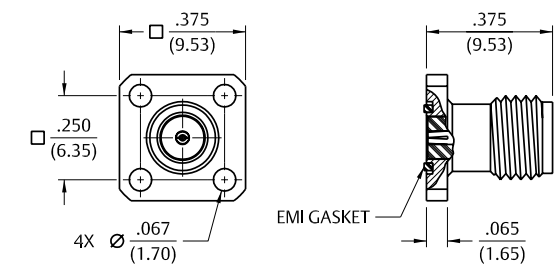
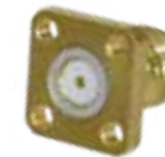

Accepts Pin Size	Gold Plated	Nickel Plated
.012 (0.30)	142-1701-551	142-1701-556
.015 (0.38)	142-1701-561	142-1701-566
.018 (0.46)	142-1701-571	142-1701-576

## 4-Hole Flange Mount Jack Receptacle – without EMI Gasket

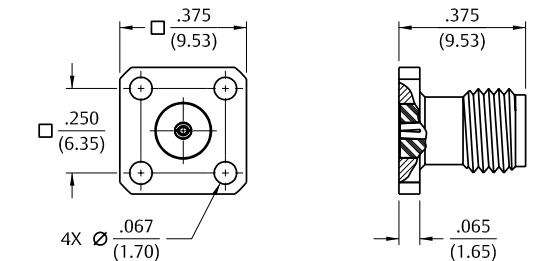

Accepts Pin Size	Gold Plated	Nickel Plated
.020 (0.51)	142-1701-581	142-1701-586
.036 (0.91)	142-1701-591	142-1701-596

## Field Replaceable Panel Mount

### 4-Hole Right Angle Flange Mount Jack Receptacle – with EMI Gasket

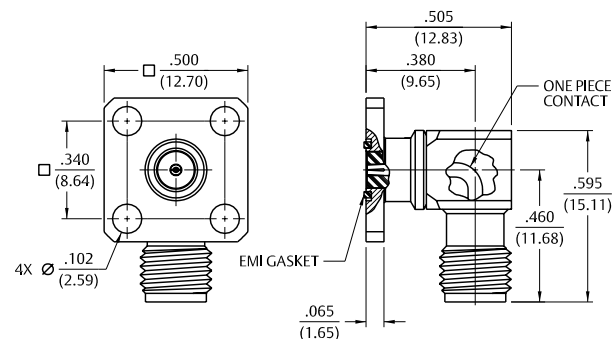

Accepts Pin Size	Gold Plated	Nickel Plated
.015 (0.38)	142-1711-511	142-1711-516
.018 (0.46)	142-1711-521	142-1711-526

### 2-Hole Flange Mount Plug Receptacle – with EMI Gasket

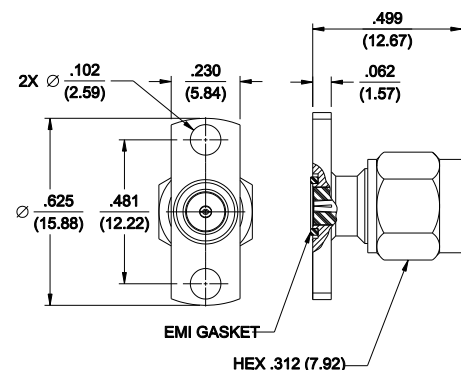

Accepts Pin Size	Gold Plated	Nickel Plated
.012 (0.30)	142-1801-601	142-1801-606
.015 (0.38)	142-1801-611	142-1801-616
.018 (0.46)	142-1801-621	142-1801-626

### 4-Hole Flange Mount Plug Receptacle – with EMI Gasket

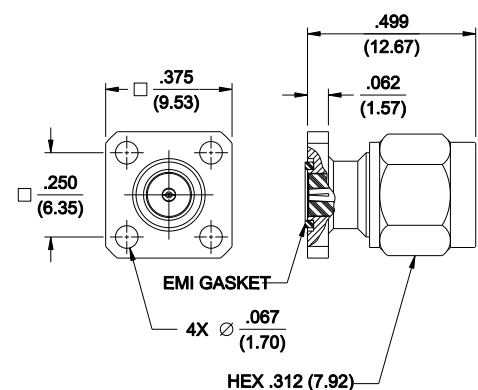

Accepts Pin Size	Gold Plated	Nickel Plated
.012 (0.30)	142-1801-551	142-1801-556
.015 (0.38)	142-1801-561	142-1801-566
.018 (0.46)	142-1801-571	142-1801-576

### Hermetic Seal Feedthrough

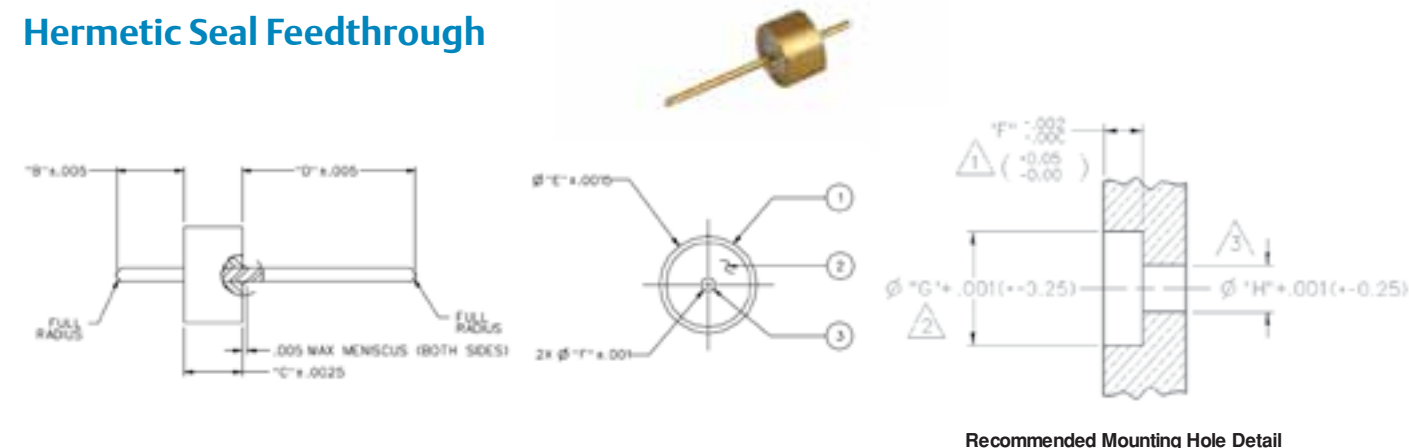

Recommended Mounting Hole Detail

Part No.	Item 1 Outer Ring	Item 2 Insulator	Item 3 Pin	"A"	"B"	"C"	"D"	"E"
142-1000-001	Kovar Gold pl .00005 min over Nickel pl .000005 min	Glass Corning 7052 or equivalent	Kovar Gold pl .00005 min over Nickel pl .000005 min	.070 (1.78)	.0625 (1.59)	.180 (4.57)	.0985 (2.50)	.012 (0.30)
142-1000-002	Kovar Gold pl .00005 min over Nickel pl .000005 min	Glass Corning 7070 or equivalent	Kovar Gold pl .00005 min over Nickel pl .000005 min	.072 (1.83)	.0625 (1.59)	.180 (4.57)	.0985 (2.50)	.015 (0.38)
142-1000-003	Kovar Gold pl .00005 min over Nickel pl .000005 min	Glass Corning 7050 or equivalent	Kovar Gold pl .00005 min over Nickel pl .000005 min	.072 (1.83)	.0600 (1.52)	.180 (4.57)	.1100 (2.79)	.018 (0.46)
142-1000-004	Kovar Gold pl .00005 min over Nickel pl .000005 min	Glass Corning 7052 or equivalent	Kovar Gold pl .00005 min over Nickel pl .000005 min	.070 (1.78)	.0600 (1.52)	.203 (5.16)	.1580 (4.01)	.020 (0.51)

### Mounting Hole Dimensions

Part No.	Pin Diameter	"F"	"G"	Air "H"	Teflon * "H"
142-1000-001	.012 (0.30)	.063 (1.60)	.102 (2.59)	.028 (0.71)	.039 (0.99)
142-1000-002	.015 (0.38)	.063 (1.60)	.102 (2.59)	.035 (0.89)	.049 (1.24)
142-1000-003	.018 (0.46)	.060 (1.52)	.114 (2.90)	.042 (1.07)	.059 (1.50)
142-1000-004	.020 (0.51)	.060 (1.52)	.162 (4.11)	.046 (1.17)	.065 (1.65)

\* Teflon is a registered trademark of DuPont

#### Notes:

- The hermetic seal should be mounted as flush as possible with the housing. Excessive recession will create a high impedance air gap which degrades electrical performance.
- The use of an additional counterbore to accommodate a solder ring for seal mounting is not recommended. A slight chamfer may be used if care is taken to completely fill the area with solder—avoid air gaps.
- Dimensions shown are given to achieve 50 Ohms with either air or a teflon insulator. A teflon insulator may be helpful insupporting small pin diameters.

### Electrical

<b>Impedance:</b>	50 Ohms
<b>Frequency Range:</b>	DC to 26.5 GHz
<b>VSWR:</b>	Dependent upon application
<b>Working Voltage:</b>	250 VRMS max at sea level
<b>Dielectric Withstanding Voltage:</b>	500 VRMS min at sea level
<b>Insulation Resistance:</b>	5000 Megohm min
<b>Insertion Loss:</b>	.015F dB max (F in GHz)

### Environmental

<b>Hermeticity:</b>	1x10 <sup>-8</sup> cc/sec at one atmosphere
<b>Solderability:</b>	MIL-STD-202, Method 209
<b>Operating Temperature:</b>	-55° C to +165° C

For more information, please contact customer service at (507) 833-8822 or (800) 247-8256 • [www.EmersonConnectivity.com](http://www.EmersonConnectivity.com)

Illustrations are shown in inches (millimeters).

## In-Series Adapters

## Jack to Jack Adapter



Gold Plated	Nickel Plated
142-0901-801	142-0901-806

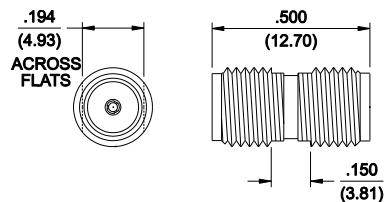

## Jack to Bulkhead Jack Adapter



Gold Plated	Nickel Plated
142-0901-401	142-0901-406

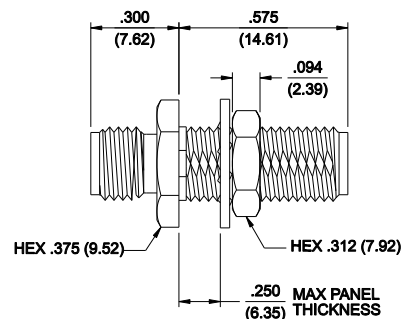

## Plug to Plug Adapter



Gold Plated	Nickel Plated
142-0901-811	142-0901-816

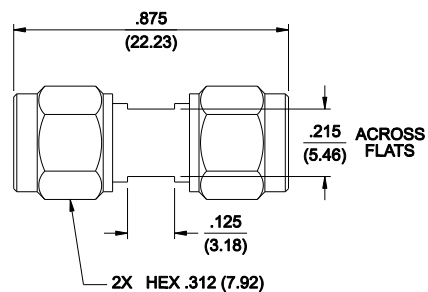

## Plug to Jack Adapter



Gold Plated	Nickel Plated
142-0901-821	142-0901-826

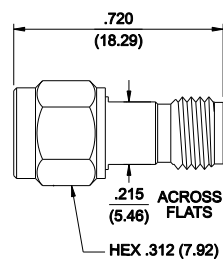

## Right Angle Jack to Jack Adapter



Gold Plated
142-0901-921

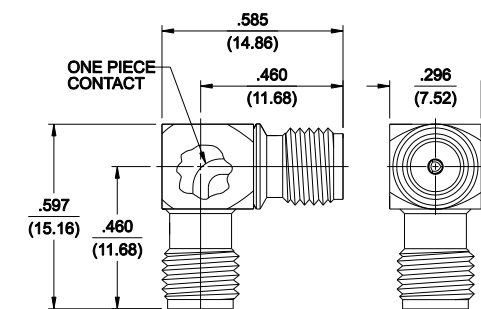

## Right Angle Plug to Plug Adapter



Gold Plated
142-0901-931

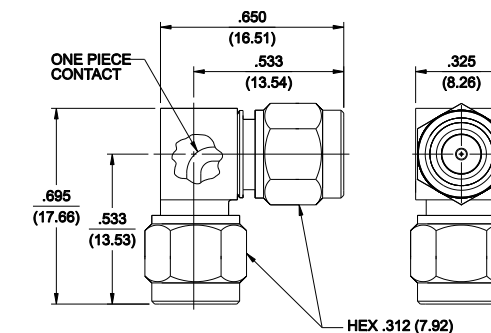

## Right Angle Jack to Plug Adapter



Gold Plated
142-0901-941

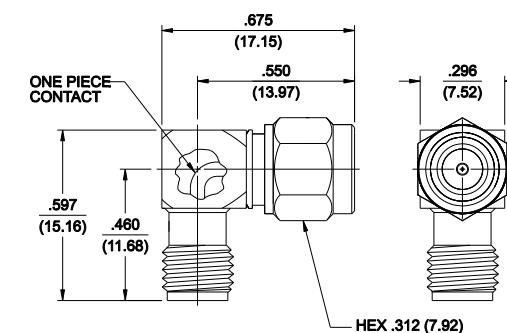

## Dummy Load Plug



Gold Plated	Nickel Plated	Resistance
142-0801-861	142-0801-866	50 Ohm

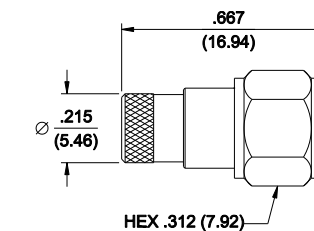

## In-Series Adapters

## Electrical Specifications

**Impedance:** 50 Ohms**Frequency Range:**

Flexible cable connectors ..... 0-12.4 GHz

Flexible cable connectors ..... 0-18.0 GHz

**VSWR:** (max) (f = GHz)

	Straight Cabled Connectors	Right Angle Cabled Connectors
RG-316, LMR-100 cable .....	1.15 + .02f	1.15 + .03f
RG-58, LMR-195 cable .....	1.17 + .025f	1.17 + .06f
RG-142 cable .....	1.17 + .02f	1.15 + .03f
LMR-200, LMR-240 cable .....	1.10 + .03f	1.10 + .06f
Uncabled receptacles.....	N/A	

**Working Voltage:** (VRMS max)

	Sea Level	70K Feet
RG-316, LMR-100, 195, 200 .....	250	65
RG-58, RG-142, LMR-240, uncabled receptacles.....	335	85

**Dielectric Withstanding Voltage:** (VRMS min at sea level)

RG-316; LMR-100, 195, 200 ..... 750

RG-58, RG-142, LMR-240, uncabled receptacles..... 1000

**Insulation Resistance:** 5000 megohms min

	Initial	After Environmental
<b>Contact Resistance:</b> (milliohms max)		
Center contact (straight cabled connectors and uncabled receptacles) .....	3.0	4.0
Center contact (right angle cabled connectors) .....	4.0	6.0
Outer contact (all connectors).....	2.0	N/A
Braid to body (gold plated connectors) .....	0.5	N/A
Braid to body (nickel plated connectors) .....	5.0	N/A

**Corona Level:** (Volts min at 70,000 feet)

RG-316, LMR-100, 195, 200 ..... 190

RG-58, RG-142, LMR-240, uncabled receptacles ..... 250

**Insertion Loss:** (dB max)Straight flexible cable connectors .....  $0.06\sqrt{f(\text{GHz})}$ , tested at 6 GHzRight angle flexible cable connectors .....  $0.15\sqrt{f(\text{GHz})}$ , tested at 6 GHzLow loss flexible straight cable connectors .....  $0.06\sqrt{f(\text{GHz})}$ , tested at 1 GHzLow loss flexible right angle cable connectors .....  $0.15\sqrt{f(\text{GHz})}$ , tested at 1 GHz

Uncabled receptacles, field replaceable ..... N/A

**RF Leakage:** (dB min, tested at 2.5 GHz)

Flexible cable connectors ..... -60 dB

Uncabled receptacles and adapters ..... N/A

**RF High Potential Withstanding Voltage:**

(VRMS min tested at 4 and 7 MHz)† RG-316; LMR-100, 195, 200..... 500

RG-58, RG-142, LMR-240, uncabled receptacles..... 670

† Avoid user injury due to misapplication. See safety advisory definitions.

## Mechanical Ratings

<b>Engagement Design:</b>	Reverse Polarity, Series SMA
<b>Engagement/Disengagement Force:</b>	2 lb-in max max
<b>Mating Torque:</b>	7 to 10 lb-in
<b>Bulkhead Mounting Nut Torque:</b>	15 lb-in
<b>Coupling Proof Torque:</b>	15 lb-in min
<b>Coupling Nut Retention:</b>	60 lbs min
<b>Contact Retention:</b>	6 lbs min axial force (captivated contacts)
	4 oz-in min 4 oz-in min

	Axial Force* (lbs)	Torque (oz-in)
<b>Cable Retention:</b>		
Connectors for RG-316, LMR-100 .....	20	N/A
Connectors for LMR195, 200 .....	30	N/A
Connectors for RG-58, LMR-240 .....	40	N/A
Connectors for RG-142 .....	45	N/A

\*Or cable breaking strength whichever is less.

**Durability:** 500 cycles minimum

## Environmental Specifications

(Meets or Exceeds the Applicable Paragraph of MIL-PRF-39012)

<b>Temperature Range:</b>	-65°C to +165°C
<b>Thermal Shock:</b>	MIL-STD-202, Method 107, Condition B
<b>Corrosion:</b>	MIL-STD-202, Method 101, Condition B
<b>Shock:</b>	MIL-STD-202, Method 213, Condition I
<b>Vibration:</b>	MIL-STD-202, Method 204, Condition D
<b>Moisture Resistance:</b>	MIL-STD-202, Method 106

## Material Specifications

<b>Bodies:</b>	Brass per ASTM B16, gold plated* per MIL-DTL-45204 .00001" min or nickel plated per ASTM B16
<b>Contacts:</b>	Male - brass per QQ-B-626, gold plated per MIL-DTL-45204 .00003" min Female - beryllium copper per ASTM B196, gold plated* per MIL-DTL-45204 .00003" min
<b>Nut Retention Spring:</b>	Beryllium copper per ASTM B196, unplated
<b>Insulators:</b>	PTFE fluorocarbon per ASTM D 1710 and ASTM D 1457 or Tefzel per ASTM D 3159
<b>Expansion Caps:</b>	Brass per ASTM B16, gold plated* per MIL-DTL-45204 .00001" min. or nickel plated per SAE-AMS2423
<b>Crimp Sleeves:</b>	Copper per ASTM B301 or brass per ASTM B16, gold plated* per MIL-DTL-45204 .00001" min or nickel plated per SAE-AMS2423
<b>Mounting Hardware:</b>	Brass (nuts) per ASTM B16 or phosphor bronze (lockwashers) per ASTM B139, gold plated* per MIL-DTL-45204 .00001" min

\* All gold plated parts include a .00005" min nickel barrier layer.

† Avoid user injury due to misapplication. See safety advisory definitions.

## Mating Engagement for SMA Reverse Polarity Series

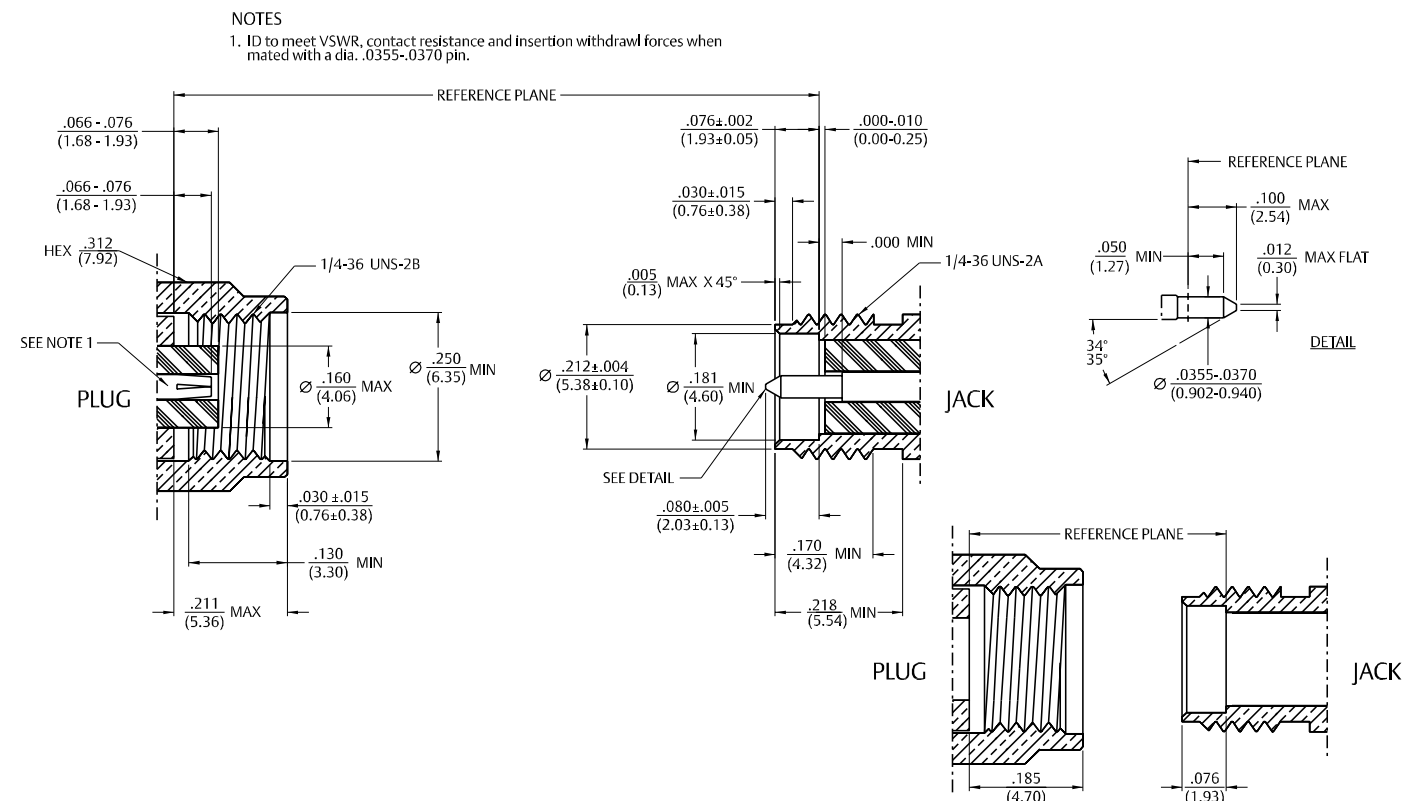

For more information, please contact customer service at (507) 833-8822 or (800) 247-8256 • www.EmersonConnectivity.com

Illustrations are shown in inches (millimeters).



## Flexible Cable

## Straight Crimp Type Plug – Solder or Crimp Captivated Contact



Cable Type	Gold Plated	Nickel Plated	"A"
RG-316/U, 188, 174, 161, LMR-100 HPF-100, RF-100	142-4403-001	142-4403-006	.706 (17.93)
RG-316 DS, 188 DS	142-4404-001	142-4404-006	.706 (17.93)
RG-58, 141, 303 LMR-195, HPF-195, RF-195	142-4407-001	142-4407-006	.706 (17.93)
RG-142, 55, 223, 400	142-4408-001	142-4408-006	.706 (17.93)
LMR-200, HPF-200, RF-200	142-4439-001	142-4439-006	.844 (21.44)
LMR-240, HPF-240, RF-240	142-4435-001	142-4435-006	.844 (21.44)

Assembly Instructions: LMR 195, 200 and 240 page 219. All other cables page 220.

## Right Angle Crimp Type Plug – Captivated Contact



Cable Type	Gold Plated	Nickel Plated	"A"	"B"
RG-316, 188, 174, 161, LMR-100, HPF-100, RF-100	142-4403-101	142-4403-106	.611 (15.52)	.470 (11.94)
RG-316 DS, 188 DS	142-4404-101	142-4404-106	.611 (15.52)	.470 (11.94)
RG-58, 141, 303, LMR-195, HPF-195, RF-195	142-4407-101	142-4407-106	.611 (15.52)	.470 (11.94)
RG-142, 55, 223, 400	142-4408-101	142-4408-106	.611 (15.52)	.470 (11.94)
LMR-200, HPF-200, RF-200	142-4439-101	142-4439-106	.611 (15.52)	.470 (11.94)
LMR-240, HPF-240, RF-240	142-4435-101	142-4435-106	.635 (16.13)	.490 (12.45)

Assembly Instructions: LMR 195, 200 and 240 page 224. All other cables page 229.  
Center conductor of cable serves as contact.

## Straight Crimp Type Bulkhead Jack – Captivated Contact

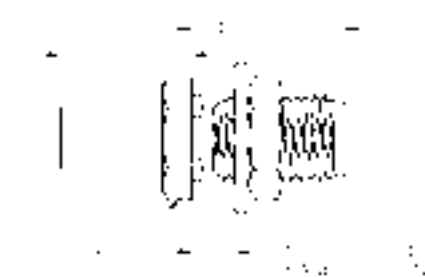

Cable Type	Gold Plated	Nickel Plated
RG-316, 188, 174, 161	142-4303-401	142-4303-406
RG-316 DS, 188 DS	142-4304-401	142-4304-406
RG-58, 141, 303	142-4307-401	142-4307-406
RG-142, 55, 223, 400	142-4308-401	142-4308-406

Assembly instructions page 219.  
Mounting hole layout figure 1 page 194.

## Straight Jack Receptacle

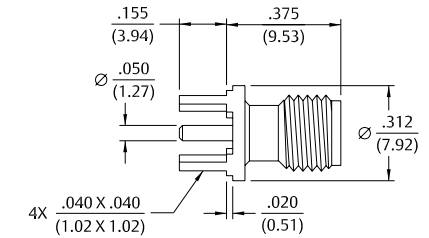

Gold Plated	Nickel Plated
142-4701-201	142-4701-206

Mounting hole layout figure 2 page 194.

## Right Angle Bulkhead Jack Receptacle



Gold Plated	Nickel Plated
142-4701-501	142-4701-506

Mounting hole layout figure 1 and 2 page 194.

## End Launch Bulkhead Jack Receptacle

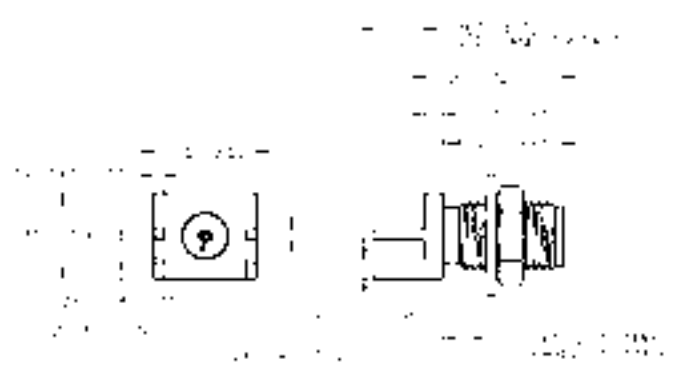

Gold Plated	Nickel Plated	Board Thickness
142-4701-801	142-4701-806	.062 (1.57)

For more information, please contact customer service at (507) 833-8822 or (800) 247-8256 • [www.EmersonConnectivity.com](http://www.EmersonConnectivity.com)

Illustrations are shown in inches (millimeters).

# Specifications

## Electrical Specifications

**Impedance:** 50 Ohms

**Frequency Range:**

Flexible cable connectors .....	0-12.4 GHz
Uncabled receptacles .....	0-18.0 GHz

**VSWR:** (max) (f = GHz)

	Straight Cabled Connectors	Right Angle Cabled Connectors
RG-316, LMR-100 cable .....	1.15 + .02f	1.15 + .03f
RG-58, LMR-195 cable .....	1.15 + .01f	1.15 + .02f
RG-142 cable .....	1.15 + .01f	1.15 + .02f
LMR-200, LMR-240 cable .....	1.10 + .03f	1.10 + .06f
Uncabled receptacles.....	N/A	

**Working Voltage:** (VRMS max)

	Sea Level	70K Feet
RG-316; LMR-100, 195, 200 .....	250	65
RG-58, RG-142, LMR-240, uncabled receptacles.....	335	85

**Dielectric Withstanding Voltage:** (VRMS min at sea level)

RG-316; LMR-100, 195, 200 .....	750
RG-58, RG-142, LMR-240, uncabled receptacles.....	1000

**Insulation Resistance:** 5000 megohms min

**Contact Resistance:** (milliohms max)

	Initial	After Environmental
Center contact (straight cabled connectors and uncabled receptacles) .....	3.0	4.0
Center contact (right angle cabled connectors) .....	4.0	6.0
Outer contact (all connectors).....	2.0	N/A
Braid to body (gold plated connectors) .....	0.5	N/A
Braid to body (nickel plated connectors) .....	5.0	N/A

**Corona Level:** (Volts min at 70,000 feet)†

RG-316, LMR-100, 195, 200 .....	190
RG-58, RG-142, LMR-240, uncabled receptacles .....	250

**Insertion Loss:** (dB max)

Straight flexible cable connectors .....	$0.06\sqrt{f}$ (GHz), tested at 6 GHz
Right angle flexible cable connectors .....	$0.15\sqrt{f}$ (GHz), tested at 6 GHz
Low loss flexible straight cable connectors .....	$0.06\sqrt{f}$ (GHz), tested at 1 GHz
Low loss flexible right angle cable connectors.....	$0.15\sqrt{f}$ (GHz), tested at 1 GHz
Uncabled receptacles, field replaceable .....	N/A

**RF Leakage:** (dB min tested at 2.5 GHz)

† Avoid user injury due to misapplication. See safety advisory definitions.

## Mechanical Ratings

**Engagement Design:**

Reverse Thread, Series SMA

**Engagement/Disengagement Force:** 2 lb-in max

**Mating Torque:** 7 to 10 lb-in

**Bulkhead Mounting Nut Torque:** 15 lb-in

**Coupling Proof Torque:** 15 lb-in min

**Coupling Nut Retention:** 60 lbs min

**Contact Retention:** 6 lbs. min axial force (captivated contacts)

4 oz-in min torque (uncabled receptacles)

**Cable Retention:**

	Axial Force* (lbs)	Torque (oz-in)
RG-316, LMR-100.....	20	N/A
LMR195, 200.....	30	N/A
RG-58, LMR-240.....	40	N/A
RG-142.....	45	N/A

\*Or cable breaking strength whichever is less.

**Durability:** 500 cycles min

# Specifications

## Environmental Specifications

(Meets or Exceeds the Applicable Paragraph of MIL-PRF-39012)

**Temperature Range:** - 65°C to + 165°C

**Thermal Shock:** MIL-STD-202, Method 107, Condition B

**Corrosion:** MIL-STD-202, Method 101, Condition B

**Shock:** MIL-STD-202, Method 213, Condition I

**Vibration:** MIL-STD-202, Method 204, Condition D

**Moisture Resistance:** MIL-STD-202, Method 106

## Material Specifications

**Bodies:**

Brass per ASTM B16, gold plated\* per MIL-DTL-45204 .00001" min or nickel plated per ASTM B16

**Contacts:**

Male - brass per QQ-B-626, gold plated\* per MIL-DTL-45204 .00003" min

Female - beryllium copper per ASTM B196, gold plated\* per MIL-DTL-45204 .00003" min

**Nut Retention Spring:** Beryllium copper per ASTM B196. Unplated

**Insulators:** PTFE fluorocarbon per ASTM D1710 and ASTM D1457 or Tefzel per ASTM D 3159

**Expansion Caps:** Brass per ASTM B16, gold plated per MIL-DTL-45204 .00001" min or nickel plated\* per SAE-AMS2423

**Crimp Sleeves:** Copper per ASTM B301 or brass per ASTM B301, gold plated\* per MIL-DTL-45204 .00001" min or nickel plated per SAE-AMS2423

**Mounting Nut:**

Brass per ASTM B16, green chromate over zinc plated Mounting Lockwasher: Phosphor bronze per ASTM B139, gold plated\* per MIL-DTL-45204 .00001" min or nickel plated per SAE-AMS2423

\* All gold plated parts include a .00005" min nickel barrier layer.

† Avoid user injury due to misapplication. See safety advisory definitions.

## Mating Engagement for SMA Reverse Thread Series

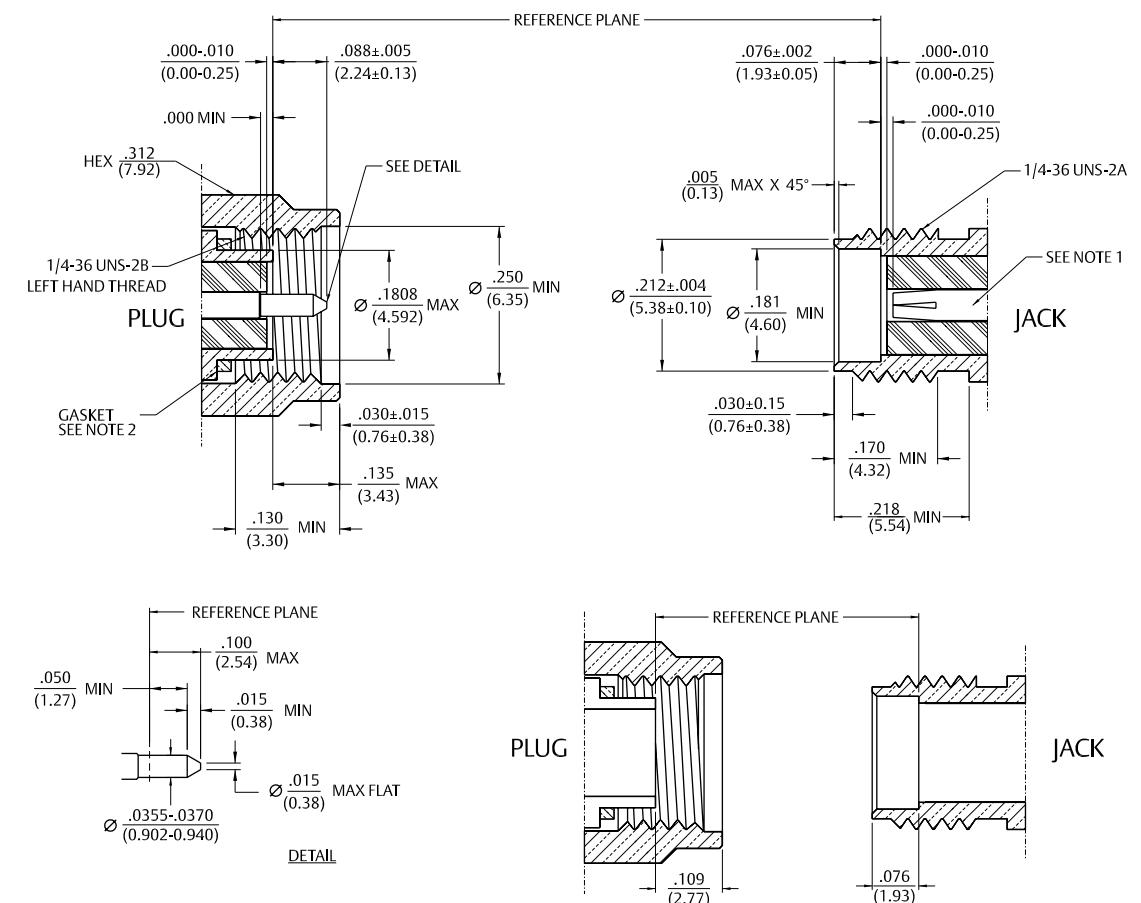

For more information, please contact customer service at (507) 833-8822 or (800) 247-8256 • www.EmersonConnectivity.com

Illustrations are shown in inches (millimeters).

## Flexible Cable

## Straight Crimp Type Plug – Solder or Crimp Captivated Contact

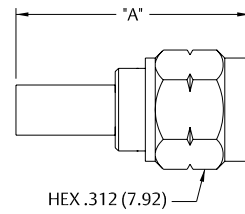

Cable Type	Gold Plated	Nickel Plated	"A"
RG-316, 188, 174, 161, LMR-100 HPF-100 RF-100	142-5403-001	142-5403-006	.706 (17.93)
RG-316 DS, 188 DS,	142-5404-001	142-5404-006	.706 (17.93)
RG-58, 141, 303 LMR-195, HPF-195, RF-195	142-5407-001	142-5407-006	.706 (17.93)
RG-142, 55, 223, 400	142-5408-001	142-5408-006	.706 (17.93)
LMR-200, HPF-200, RF-200	142-5439-001	142-5439-006	.844 (21.44)
LMR-240, HPF-240, RF-240	142-5435-001	142-5435-006	.844 (21.44)

Assembly Instructions: LMR 195, 200 and 240 page 220. All other cables page 219.

## Right Angle Crimp Type Plug – Captivated Contact

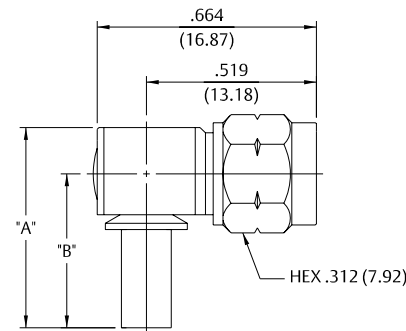

Cable Type	Gold Plated	Nickel Plated	"A"	"B"
RG-316, 188, 174, 161, LMR-100 HPF-100 RF-100	142-5403-101	142-5403-106	.611 (15.52)	.470 (11.94)
RG-316 DS 188 DS	142-5404-101	142-5404-106	.611 (15.52)	.470 (11.94)
RG-58, 141, 303, LMR-195 HPF-195 RF195	142-5407-101	142-5407-106	.611 (15.52)	.470 (11.94)
RG-142, 55, 223, 400	142-5408-101	142-5408-106	.611 (15.52)	.470 (11.94)
LMR-200 HPF-200 RF-200	142-5439-101	142-5439-106	.611 (15.52)	.470 (11.94)
LMR-240 HPF-240 RF-240	142-5435-101	142-5435-106	.635 (16.13)	.490 (12.45)

Assembly instructions: LMR 195, 200 and 240 page 229. All other cables page 224.

## Straight Crimp Type Bulkhead Jack – Solder or Crimp

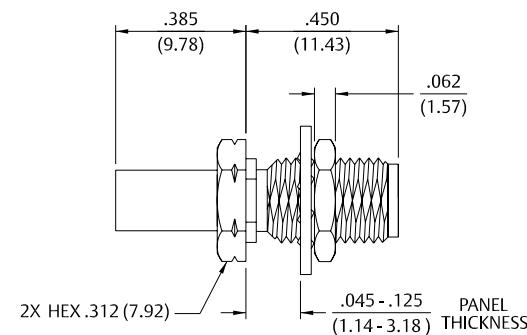

Cable Type	Gold Plated	Nickel Plated
RG-316, 188, 174, 161	142-5303-401	142-5303-406
RG-316 DS, 188 DS	142-5304-401	142-5304-406
RG-58, 141, 303	142-5307-401	142-5307-406
RG-142, 55, 223, 400	142-5308-401	142-5308-406

Assembly instructions page 219.  
Mounting hole layout figure 1 page 194.

## Straight Jack Receptacle



Gold Plated	Nickel Plated
142-5701-201	142-5701-206

Mounting hole layout figure 2 page 194.

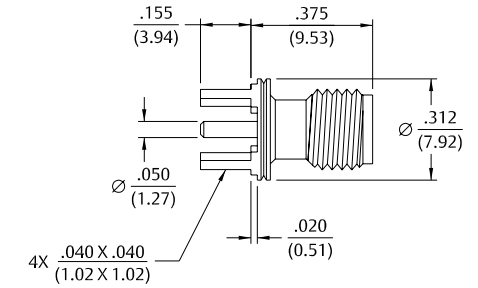

## Right Angle Bulkhead Jack Receptacle



Gold Plated	Nickel Plated
142-5701-501	142-5701-506

Mounting hole layout figures 1 and 2 page 194.

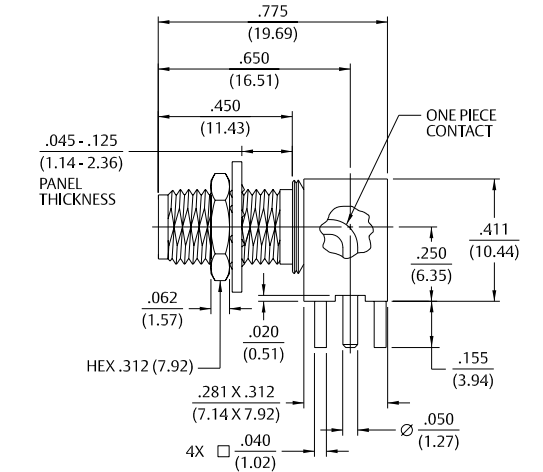

## End Launch Bulkhead – Round Contact



Gold Plated	Nickel Plated	Board Thickness
142-5701-801	142-5701-806	.062 (1.57)

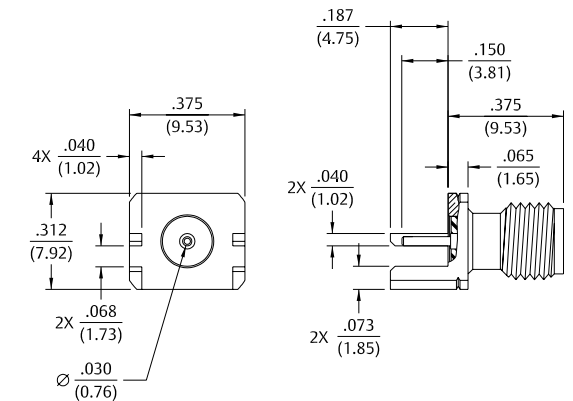

## End Launch Bulkhead Jack Receptacle – Round Contact



Gold Plated	Nickel Plated	Board Thickness
142-5701-811	142-5701-816	.062 (1.57)

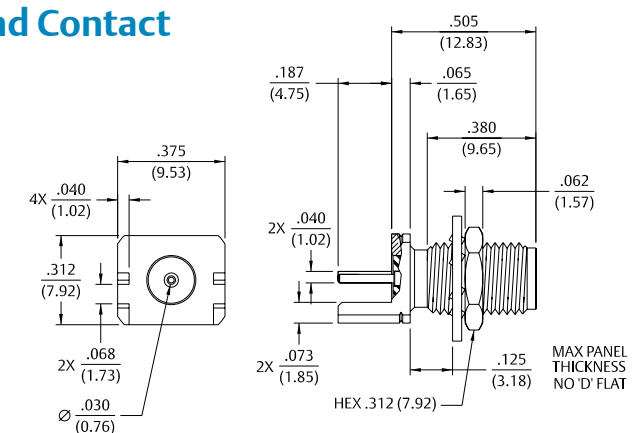

For more information, please contact customer service at (507) 833-8822 or (800) 247-8256 • [www.EmersonConnectivity.com](http://www.EmersonConnectivity.com)

Illustrations are shown in inches (millimeters).

# Specifications

## Electrical Specifications

**Impedance:** 50 Ohms

**Frequency Range:** Flexible cable connectors.....0-12.4 GHz  
Uncabled receptacles .....0-18.0 GHz

**VSWR:** (max) (f = GHz)

	Straight Cabled Connectors	Right Angle Cabled Connectors
RG-316 cable .....	1.15 + .02f	1.15 + .03f
RG-58 cable .....	1.15 + .01f	1.15 + .02f
Uncabled receptacles.....	N/A	
<b>Working Voltage:</b> (VRMS max)†	<b>Sea Level</b>	<b>70K Feet</b>
RG-316 .....	250	65
RG-58, uncabled receptacles .....	335	85

**Dielectric Withstanding Voltage:** (VRMS min at sea level)†

RG-316 .....	750
RG-58, uncabled receptacles .....	1000

**Insulation Resistance:** 5000 megohms min

**Contact Resistance:** (milliohms max )

	Initial	After Environmental
Center contact (straight cabled connectors, uncabled receptacles).....	3.0	4.0
Center contact (right angle cabled connectors).....	4.0	6.0
Outer contact (all connectors).....	2.0	N/A
Braid to body .....	0.5	N/A

**Corona Level:** (Volts min at 70,000 feet)†

RG-316 190	
RG-58, uncabled receptacles .....	250

**Insertion Loss:** (dB max)

Straight flexible cable connectors .....	$0.06 \sqrt{f \text{ (GHz)}}$ , tested at 6 GHz
Right angle flexible cable connectors .....	$0.15 \sqrt{f \text{ (GHz)}}$ , tested at 6 GHz
Uncabled receptacles .....	N/A

**RF Leakage:** (dB min tested at 2.5 GHz)

Flexible cable connectors .....	-60 dB
Uncabled receptacles .....	N/A

**RF High Potential Withstanding Voltage:** (VRMS minimum, tested at 4 and 7 MHz)†

RG-316 .....	500
RG-58, uncabled receptacles .....	670

† Avoid user injury due to misapplication. See safety advisory definitions inside front cover.

## Mechanical Specifications

**Engagement Design:** MIL-STD-348, Series SMA

**Engagement/Disengagement Force:** 2 lb-in min max

**Mating Torque:** 7 to 10 lb-in min

**Coupling Proof Torque:** 15 lb-in min

**Coupling Nut Retention:** 60 lbs min

**Contact Retention:** 6 lbs min axial force (captivated contacts)  
4 oz-in min torque (uncabled receptacles)

Cable Retention:	Axial Force* (lbs)	Torque (oz-in)
RG-316 .....	20	N/A
RG-58 .....	40	N/A

\*Or cable breaking strength whichever is less.

**Durability:** 500 cycles min

## Environmental Specifications

(Meets or Exceeds the Applicable Paragraph of MIL-PRF-39012)

**Temperature Range:** -65°C to +165°C

**Thermal Shock:** MIL-STD-202, Method 107, Condition B

**Corrosion:** MIL-STD-202, Method 101, Condition B

**Shock:** MIL-STD-202, Method 213, Condition I

**Vibration:** MIL-STD-202, Method 204, Condition D

**Moisture Resistance:** MIL-STD-202, Method 106

## Material Specifications

(See non-magnetic materials page 10)

† Avoid user injury due to misapplication. See safety advisory definitions inside front cover.

## Straight Crimp Type Plug (3-piece) – Captivated Contact



Cable Type	Gold Plated
RG-316, 188, 174	142-9403-011
RG-316 DS, 188 DS	142-9404-011
RG-58, 141, 303	142-9407-001

Assembly instructions page 219.

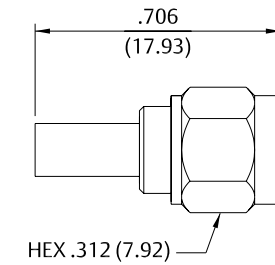

## Right Angle Crimp Type Plug – Captivated Contact



Cable Type	Gold Plated
RG-316, 188, 174	142-9403-101
RG-316 DS, 188 DS	142-9404-101
RG-58, 141	142-9407-101

Assembly instructions page 224.

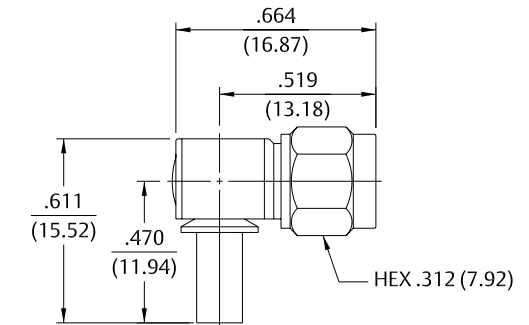

## Straight Crimp Type Bulkhead Jack (3-piece) – Captivated Contact



Cable Type	Gold Plated
RG-316, 188, 174	142-9303-411

Assembly instructions page 219.

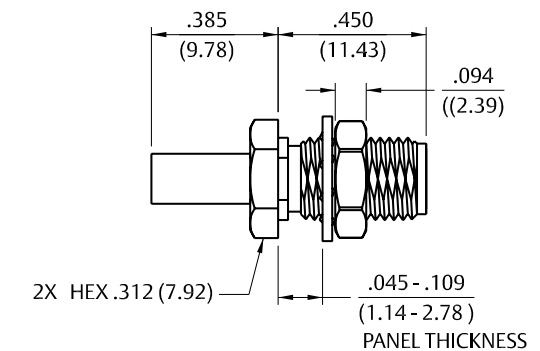

# PC Mount

## Straight Jack Receptacle



Gold Plated	"A"
142-9701-201	.155 (3.94)
142-9701-211	.110 (2.79)

Mounting hole layout figure 3 on page 194.

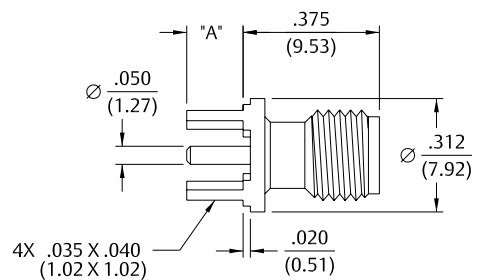

## Straight Plug Receptacle



Gold Plated
142-9801-201

Mounting hole layout figure 3 on page 194.

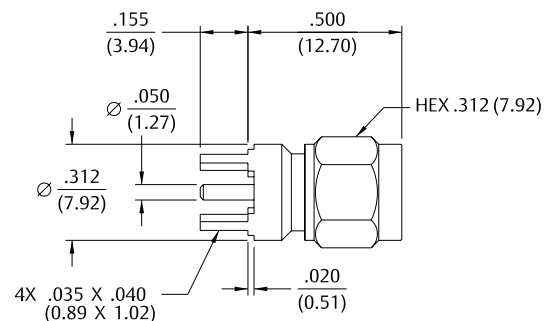

## Right Angle Jack Receptacle



Gold Plated
142-9701-301

Mounting hole layout figure 3 on page 194.

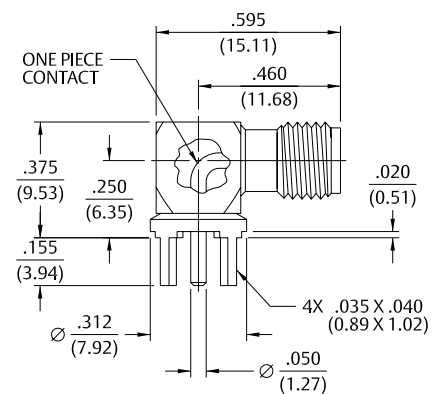

# PC Mount

## End Launch Jack Receptacle – Round Contact



Gold Plated	Board Thickness
142-9701-801	.062 (1.57)

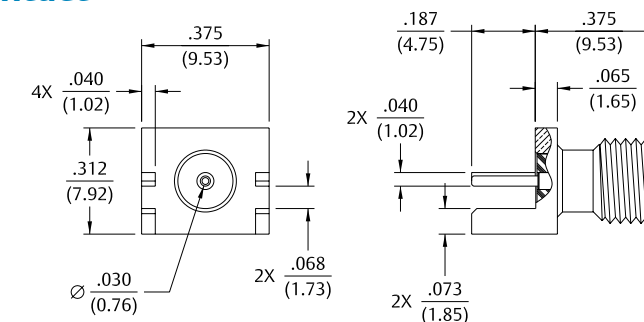

## End Launch Jack Receptacle – Tab Contact



Gold Plated	Board Thickness
142-9701-811	.062 (1.57)

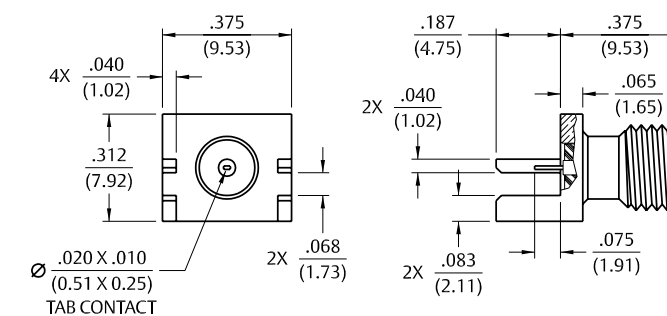

## Specifications

### Electrical Specifications

<b>Impedance:</b>	50 Ohms	
<b>Frequency Range:</b>	0-26.5 GHz	
<b>VSWR: (max)</b>	1.05+.02f(GHz) max at 0-18 GHz, <1.50 typical at 18-26.5 GHz	
<b>Working Voltage:</b>	170 VRMS max at sea level, 45 VRMS max at 70K feet	
<b>Dielectric Withstanding Voltage:</b>	500 VRMS min at sea level	
<b>Insulation Resistance:</b>	1000 Megohms min	
<b>Contact Resistance: (milliohms max)</b>	<u>Initial</u>	<u>After Environmental</u>
Center Contact .....	3.0	4.0
Outer Conductor .....	2.0	NA
<b>Corona Level:</b> .....	125 Volts at 70K feet	
<b>Insertion Loss:</b> .....	(Dependant upon application)	
<b>RF Leakage:</b>	Not Applicable	
<b>RF High Potential Withstanding Voltage:</b>	335 VRMS min at 4 and 7 MHz	

### Mechanical Specifications

<b>Engagement Design:</b>	MIL-STD-348, Series SMA
<b>Engagement/Disengagement Force:</b>	2 lb-in max
<b>Mating Torque:</b>	7 to 10 lb-in
<b>Contact Retention:</b>	6 lbs min axial force, 4 oz-in min radial torque

### Environmental Ratings

(Meets or Exceeds the Applicable Paragraph of MIL-PRF-39012)

<b>Temperature Range:</b>	-65°C to +165°C
<b>Thermal Shock:</b>	MIL-STD-202, Method 107, Condition B - Except 115°C High Temp
<b>Corrosion:</b>	MIL-STD-202, Method 101, Condition B
<b>Shock:</b>	MIL-STD-202, Method 213, Condition I
<b>Vibration:</b>	MIL-STD-202, Method 204, Condition D
<b>Moisture Resistance:</b>	MIL-STD-202, Method 106

### Mating Engagement for SMA Series Thickwall Plug Compatible with MIL-STD-348

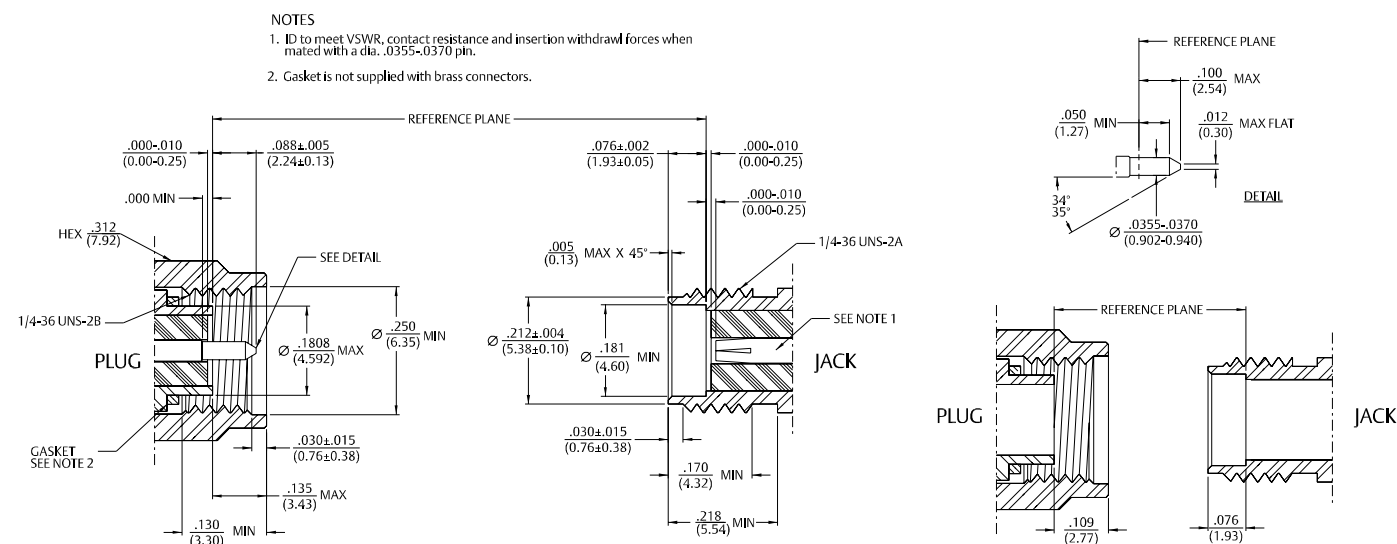

## Applications & Design Features

### High Frequency SMA End Launch Connectors for Microwave PC Board Substrates

The Johnson line of High Frequency End Launch connectors are used to transition microwave energy from coaxial to planar transmission line structures. These connectors provide a unique solution for microwave engineers who fabricate circuit designs on very thin high frequency board substrates. The in-line connector design minimizes reflections as compared to a right-angle (perpendicular) pc mount transition.

- Cellular Linear Power Amplifiers
- Broadband MMIC Power Amplifiers
- Microwave Filters, Mixers and Combiners
- Wireless Infrastructure Antennas
- DBS Low-Noise Block Down Converters
- Remote Sensing and Metering
- Global Positioning Satellite Antennas
- Phased Array Antennas
- Radar Systems
- High Speed Routers and Switches
- Automated Test Equipment
- RF Identification Tags

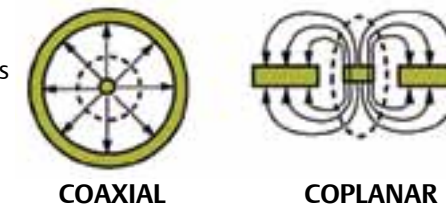

High Frequency End Launch connectors are designed to attach directly to a high frequency coplanar waveguide (CPW) circuit board transmission line, although other lines such as microstrip can be used with good results. These connectors can be used on high frequency PC board substrate layers as thin as 8 mils, and operate at frequencies up to 26.5 GHz (see Return Loss chart).

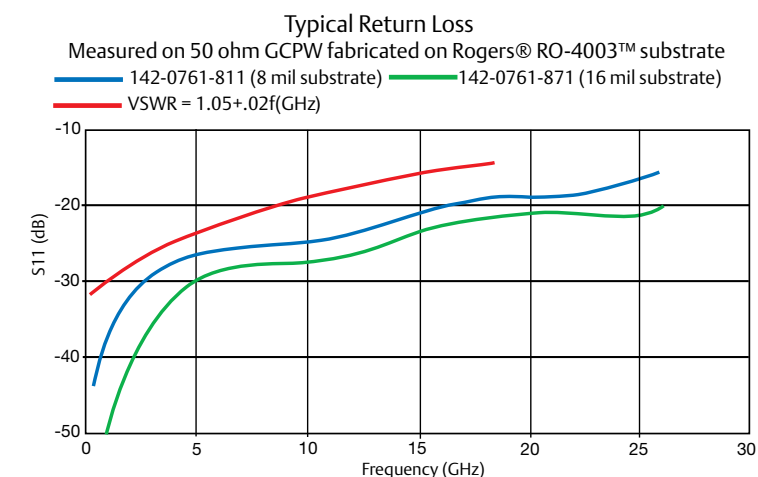

### Design Features

This connector is an economical alternative to other high frequency designs in the industry. This design differentiates itself from other launch connectors:

- Design of the connector is self contained, no external mounting screws, adapter sections, spring clips, etc. are required for assembly to the circuit board.
- Center contact pin does not require special orientation to the surface of the circuit board. The center contact is mechanically captivated and optimized to maintain proper impedance while withstanding torque and axial force stress.
- Output coax of the connector at board launch is sized appropriately to match the thickness of the high frequency board substrate. The output coax section extends well within the connector while maintaining constant inner and outer coaxial diameters.
- Signal side grounding legs of the connector are spaced close enough to keep grounding paths short, but far enough apart to maintain constant impedance in the launch transition area.
- Signal side grounding legs and GCPW geometry control radiation, no additional shielding is required to prevent signal cross-talk effects in the transition area. The launch transition is effectively isolated from adjacent transmis-

sion lines in the signal plane.

- Connector is not locked into position when placed on the circuit board. Intentional floating design allows proper alignment in X, Y and Z, minimizing discontinuities due to manufacturing tolerances.
- The distinctive through hole mounting technique allows the use of one connector with varying circuit board thicknesses. The connectors are also available in a traditional straddle mount end launch design, which was pioneered by Emerson Network Power Connectivity Solutions over 30 years ago.
- A small amount of PTFE insulation projects from the rear mating plane of the connector, acting as a seal when soldering the center conductor pin to the trace. The connector is held against the circuit board edge during the soldering process, compressing the PTFE insulation. This effectively creates a barrier between the inner and outer conductors, preventing the bridging of solder.
- Appropriate sized connectors do not require additional compensation to standard coplanar or microstrip matched impedance line geometries. Transition can be fine-tuned by pulling the trace back a slight amount from the board edge.

For more information, please contact customer service at (507) 833-8822 or (800) 247-8256 • [www.EmersonConnectivity.com](http://www.EmersonConnectivity.com)

Illustrations are shown in inches (millimeters).

## PC Mount

## Jack Receptacle – Round Body

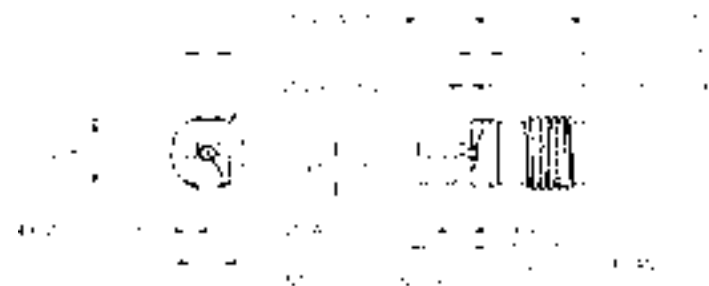

Gold Plated	High Frequency Substrate Thickness	"A"	"B"	"C"
142-0761-801	.008 (0.20) - .014 (0.36)	.010 (0.25)	.050 (1.27)	.096 (2.44)
142-0761-821	.014 (0.36) - .020 (0.51)	.015 (0.38)	.067 (1.70)	.113 (2.87)

Assembly instructions page 228.

## Jack Receptacle, Square Body



Gold Plated	High Frequency Substrate Thickness	"A"	"B"	"C"
142-0761-811	.008 (0.20) - .014 (0.36)	.010 (0.25)	.050 (1.27)	.096 (2.44)
142-0761-831	.014 (0.36) - .020 (0.51)	.015 (0.38)	.067 (1.70)	.113 (2.87)

Assembly instructions page 228.

## Jack Receptacle – PC Mount, Round Body with Thick Legs



Gold Plated	High Frequency Substrate Thickness	"A"	"B"	"C"
142-0761-881	.008 (0.20) - .014 (0.36)	.010 (0.25)	.050 (1.27)	.096 (2.44)
142-0771-821	.014 (0.36) - .020 (0.51)	.015 (0.38)	.067 (1.70)	.113 (2.87)

Assembly instructions page 228.

\* Coupling proof torque 8 inch pounds maximum without support wrench.

## PC Mount

## Jack Receptacle – for .062 Board, Round Body

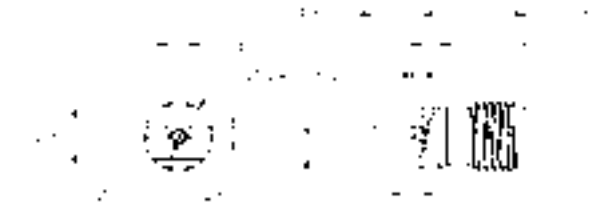

Gold Plated	High Frequency Substrate Thickness	"A"	"B"	"C"
142-0761-841	.008 (0.20) - .014 (0.36)	.010 (0.25)	.050 (1.27)	.032 (0.81)
142-0761-861	.014 (0.36) - .020 (0.51)	.015 (0.38)	.067 (1.70)	.040 (1.02)

Assembly instructions page 228.

## Jack Receptacle – for .062 Board, Square Body



Gold Plated	High Frequency Substrate Thickness	"A"	"B"	"C"
142-0761-851	.008 (0.20) - .014 (0.36)	.010 (0.25)	.050 (1.27)	.032 (0.81)
142-0761-871	.014 (0.36) - .020 (0.51)	.015 (0.38)	.067 (1.70)	.040 (1.02)

Assembly instructions page 228.

## Jack Receptacle – for .062 Board, Round Body with Thick Legs

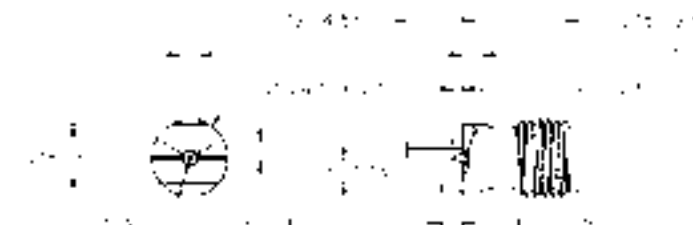

Gold Plated	High Frequency Substrate Thickness	"A"	"B"	"C"
142-0761-891	.008 (0.20) - .014 (0.36)	.010 (0.25)	.050 (1.27)	.032 (0.81)
142-0771-831	.014 (0.36) - .020 (0.51)	.015 (0.38)	.067 (1.70)	.040 (1.02)

Assembly instructions page 228.

\* Coupling proof torque 8 inch pounds maximum without support wrench.

## Specifications

### Electrical Ratings

**Impedance:** 50 Ohms

**Frequency Range:**

Flexible cable connectors .....	0-12.4 GHz
Uncabled receptacles.....	0-18.0 GHz
Straight Semi-Rigid cable connectors.....	0-26.5 GHz

**VSWR:** (max) (f = GHz)

	Straight Cabled Connectors	Right Angle Cabled Connectors
RG-316, LMR-100 cable .....	1.15+.02f	1.15+.03f
RG-58, LMR-195 cable .....	1.15+.01f	1.15+.02f
RG-142 cable .....	1.15+.01f	1.15+.02f
RG-405 cable (0 - 18 GHz) .....	1.07+.008f	
RG-405 cable (18 - 26.5 GHz) .....	1.35 max	
RG-402 cable (w/contact).....	1.05+.008f	
RG-402 cable (w/o contact).....	1.035+.005f	

**Insertion Loss:** (dB max)

Straight flexible cable connectors .....	0.06 $\sqrt{f}$ (GHz), tested at 6 GHz
Right angle flexible cable connectors .....	0.15 $\sqrt{f}$ (GHz), tested at 6 GHz
Straight Semi-Rigid cable connectors with contact.....	0.03 $\sqrt{f}$ (GHz), tested at 10 GHz
Straight Semi-Rigid cable connectors w/o contact.....	0.03 $\sqrt{f}$ (GHz), tested at 16 GHz
Uncabled receptacles .....	N/A

**Working Voltage:** (VRMS max)

	Sea Level	70K Feet
RG-316, LMR-100, 195 .....	250	65
RG-58, RG-142, RG-405, uncabled receptacles, RG-402 w/o contact.....	335	85
RG-402 with contact.....	500	125

**Dielectric Withstanding Voltage:** (VRMS min at sea level) †

	Sea Level
RG-316, LMR-100, 195 .....	750
RG-58, RG-142, RG-405, uncabled receptacles .....	1000
RG-402 with contact.....	1500
RG-402 w/o contact.....	N/A

**Corona Level:** (Volts min at 70,000 feet)

	70K Feet
RG-316, LMR-100, 195 .....	190
RG-58, RG-142, .086 Semi-Rigid, uncabled receptacles, RG-402 w/o contact.....	250
RG-402 with contact .....	375

**Insulation Resistance:** 5000 Megohms min

	Initial	After Environmental
Contact Resistance: (milliohms max)		
Center contact (straight cabled connectors and uncabled receptacles) .....	3.0*	4.0*
Center contact (right angle cabled connectors) .....	4.0	6.0
Outer contact (all connectors) .....	2.0	N/A
Braid to Body (gold plated bodies).....	0.5	N/A

\*N/A where the cable center conductor is used as a contact

**RF Leakage:** (dB min, tested at 2.5 GHz)

Flexible cable connectors and RG-402 connectors w/o contact .....	-60
RG-405 connectors and RG-402 connectors with contact .....	-90
Uncabled receptacles .....	N/A

**RF High Potential Withstanding Voltage:** (VRMS min, tested at 4 and 7 MHz)

RG-316, LMR-100, 195 .....	500
RG-58, RG-142, RG-405, RG-402 cable w/o contact, Uncabled receptacles .....	670
RG-402 with contact .....	1000

† Avoid user injury due to misapplication. See safety advisory definitions.

### Mechanical Specifications

<b>Engagement Design:</b>	MIL-STD-348, Series SMA
<b>Durability:</b>	500 cycles min 100 cycles min for RG-402 connectors w/o contact
<b>Engagement/Disengagement Force:</b>	2 inch-pounds max
<b>Mating Torque:</b>	7 to 10 lb-in
<b>Bulkhead Mounting Nut Torque:</b>	15 lb-ins recommended
<b>Coupling Proof Torque:</b>	15 lb-ins min
<b>Coupling Nut Retention:</b>	60-lbs min
<b>Contact Retention:</b>	6 lbs. min axial force (captivated contacts) 4 oz-in min torque (uncabled receptacles)

**Cable Retention: (minimum\*)**

	Axial Force (lbs)	Torque (oz-in)
RG-316, LMR-100 .....	20	N/A
RG-58.....	40	N/A
RG-142 Cabled .....	45	N/A
RG-405.....	30	16
RG-402 .....	60	55
LMR-195.....	30	N/A

\* Or cable breaking strength, whichever is less

### Environmental Specifications

(Meets or Exceeds the Applicable Paragraph of MIL-PRF-39012)

<b>Temperature Range:</b>	-65°C to +165°C
<b>Thermal Shock:</b>	MIL-STD-202, Method 107, Condition B (except +85°C high temperature)
<b>Corrosion:</b>	MIL-STD-202, Method 101, Condition B
<b>Shock:</b>	MIL-STD-202, Method 213, Condition I
<b>Vibration:</b>	MIL-STD-202, Method 204, Condition D
<b>Moisture Resistance:</b>	MIL-STD-202, Method 106

### Material Specifications

<b>Bodies:</b>	Stainless Steel, type 303, per ASTM A 582, passivated per MIL-DTL-14072 (EL 300), or gold Plated per MIL-G-45204 .00005" min
<b>Contacts:</b>	Male - Brass per ASTM B16, Gold plated* per MIL-G-45204 (.00005" min) Female – Beryllium Copper per ASTM B196, Gold plated* per MIL-G-45204 (.00005" min)
<b>Insulators:</b>	PTFE Fluorocarbon per ASTM D1710 and ASTM D1457
<b>Gaskets:</b>	Silicon Rubber per A-A-59588A
<b>Expansion Caps:</b>	Brass per ASTM B16, gold plated per MIL-G-45204 .00005" min or nickel plated per AMS-QQ-N-290
<b>Crimp Sleeves:</b>	Copper per ASTM A75, gold plated per MIL-G-45204 .0005" min or nickel per AMS-QQ-N-290 plated (.00005" min)
<b>Nut Retention Spring (Plugs):</b>	Beryllium Copper per ASTM B196, un-plated
<b>Mounting Hardware:</b>	Stainless Steel, type 303, Per ASTM A582, passivated per MIL-DTL-14072 (EL 300), or gold plated* per MIL-G-45204 .00005" min

Note: All Gold plated parts include a .00005" min Nickel under plated barrier layer.

For more information, please contact customer service at (507) 833-8822 or (800) 247-8256 • www.EmersonConnectivity.com

Illustrations are shown in inches (millimeters).

## Specifications



## Specifications

## Mating Engagement for Stainless Steel SMA Series Per MIL-STD-348A

## NOTES

1. ID to meet VSWR, contact resistance and insertion withdrawl forces when mated with a dia. .0355-.0370 pin.
2. Gasket is not supplied with brass connectors.

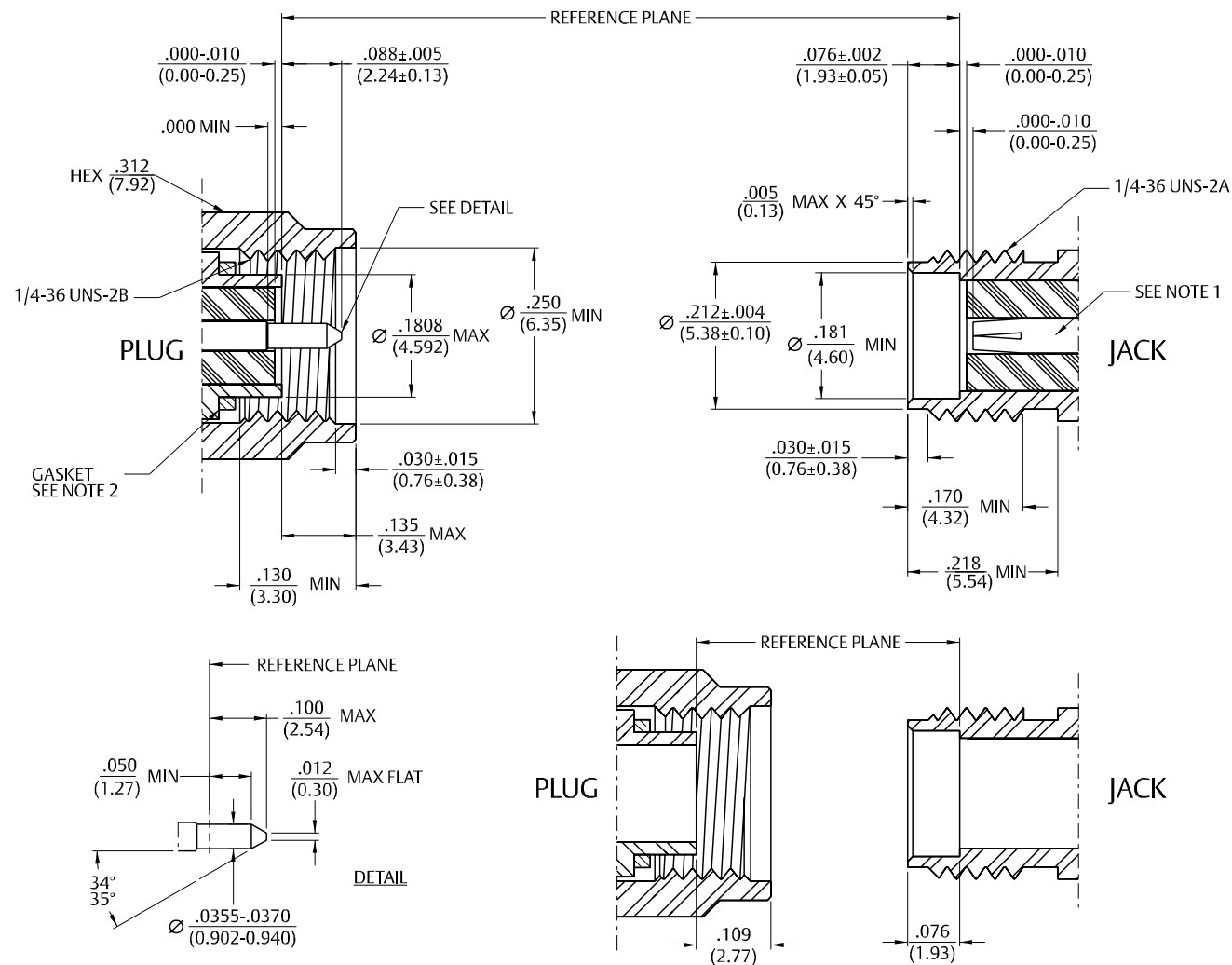

## Straight Solder Type Plug – with Contact, Captive Nut Thin Wall

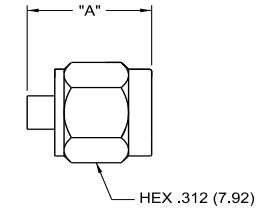

Cable Type	Gold Plated Body	"A"
RG-405	141-0693-002	.405
RG-402	141-0694-002	.440

Assembly instructions page 214.

## Straight Solder Type Plug – Without Contact, Thread-On Nut

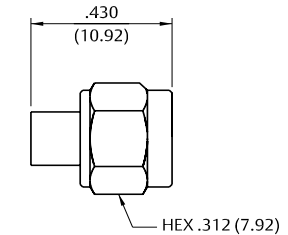

Cable Type	Gold Plated Body
RG-402	141-0694-012

Assembly instructions page 214.

## Straight Solder Type Plug with Captivated Solderless Contact, Captive Nut and Thick Wall Interface

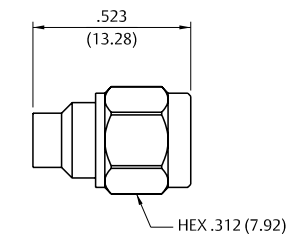

Cable Type	Gold Plated Body
RG-405	141-0693-062
RG-402	141-0694-062

Assembly instructions page 222.

## Semi-Rigid

## Straight Solder Type Jack



Cable Type	Gold Plated Body
RG-405	141-0593-001
RG-402	141-0594-001

Assembly instructions page 214.

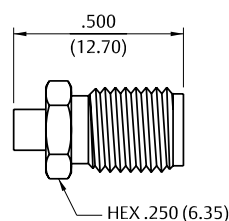

## Straight Solder Type Bulkhead Jack with O-Ring



Cable Type	Gold Plated Body
RG-405	141-0593-401
RG-402	141-0594-401

Assembly instructions page 214.

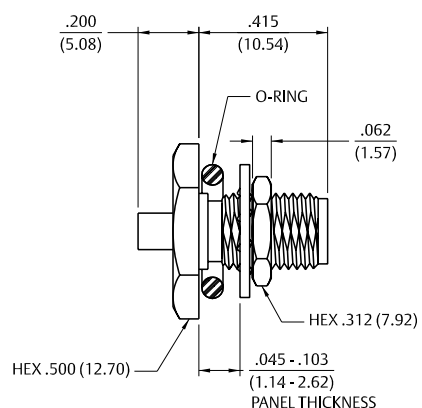

## Straight Solder Type Bulkhead Jack with Captivated Solderless Contact and O-Ring



Cable Type	Gold Plated Body
RG-405	141-0593-421
RG-402	141-0594-421

Assembly instructions page 222.

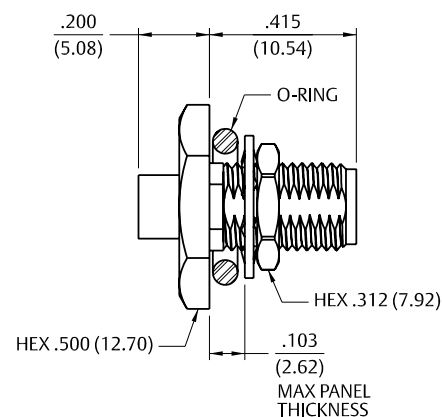

## Flexible Cable

## Straight Crimp Type Plug (3-piece) – Solder or Crimp Captivated Contact



Cable Type	Passivated
RG-161, 174, 188, 316, LMR-100, HPF-100, RF-100	141-0403-012
RG-188 DS, RG-316 DS	141-0404-012
RG-58, 141, 303, LMR-195, HPF-195, RF-195	141-0407-012
RG-55, 142, 223, 400	141-0408-012

Assembly instructions page 219.

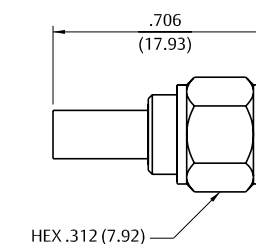

## Right Angle Crimp Type Plug – Captivated Contact



Cable Type	Passivated	"A"	"B"	"C"	"D"
RG-161, 174, 188, 316	141-0403-102	.652	.527	.593	.467
RG-188 DS, RG-316 DS	141-0404-112	.652	.527	.593	.467
RG-58, 141, 303	141-0407-102	.636	.519	.596	.471
RG-55, 142, 223, 400	141-0408-102	.636	.519	.596	.471

Assembly instructions page 224.

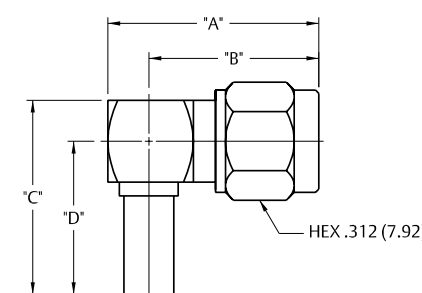

## Straight Crimp Type Bulkhead Jack (3-piece) – Solder or Crimp Captivated Contact



Cable Type	Passivated
RG-161, 174, 188, 316	141-0303-412
RG-188 DS, RG-316 DS	141-0304-412
RG-58, 141, 303	141-0307-412
RG-55, 142, 223, 400	141-0308-412

Assembly instructions page 219.

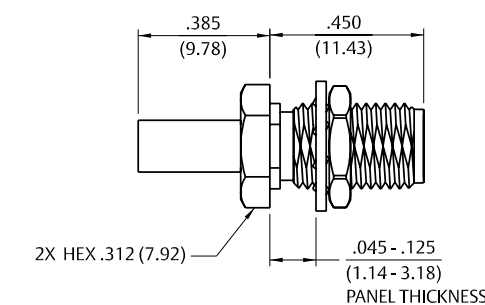

# PC Mount, Bulkhead and Panel Mount

## Right Angle PC Mount Jack Receptacle



Gold Plated  
141-0701-301

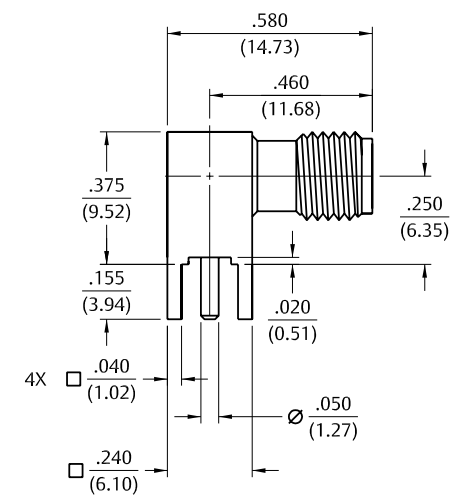

## Straight PC Mount Jack Receptacle



Gold Plated  
141-0701-201

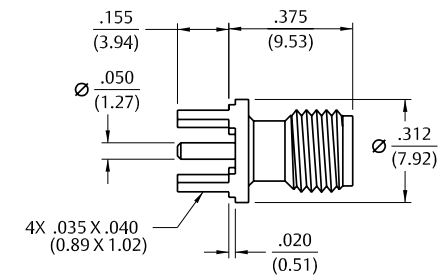

## Rear Mount Bulkhead Jack Receptacle



Passivated  
141-0701-402

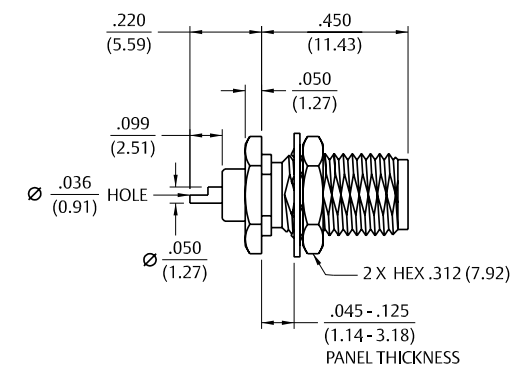

## 2-Hole Flange Mount Jack Receptacle – Flush Dielectric



Passivated  
141-0701-602

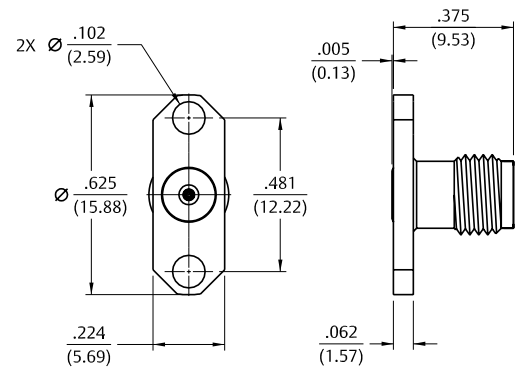

# Panel Mount

## 4-Hole Flange Mount Jack Receptacle – Flush Dielectric



Passivated  
141-0701-612

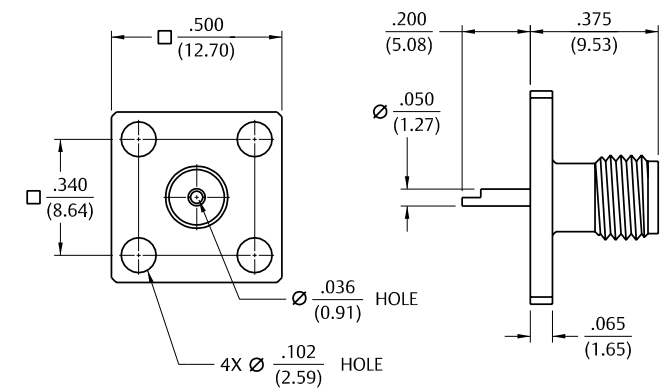

## 2-Hole Flange Mount Jack Receptacle – Extended Dielectric



Passivated  
141-0701-622

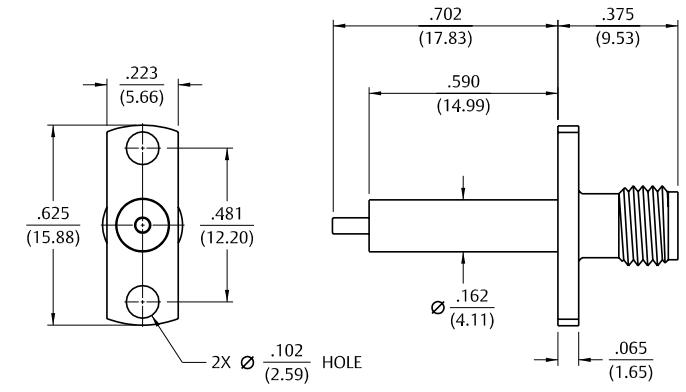

## 4-Hole Flange Mount Jack Receptacle – Extended Dielectric



Passivated  
141-0701-632

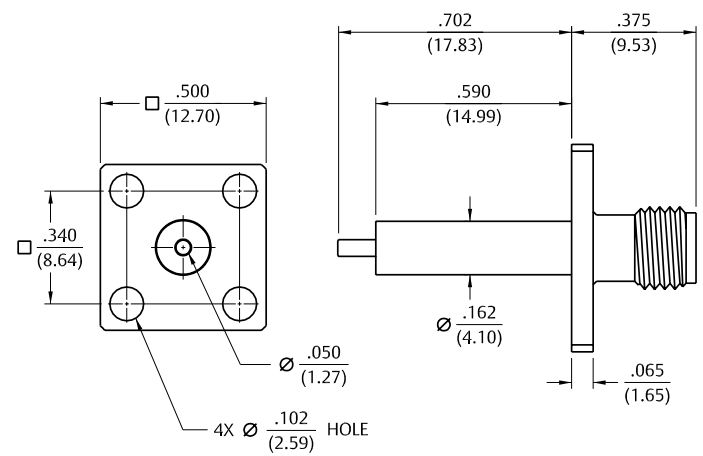

For more information, please contact customer service at (507) 833-8822 or (800) 247-8256 • [www.EmersonConnectivity.com](http://www.EmersonConnectivity.com)  
Illustrations are shown in inches (millimeters).

3	MMCX Connectors
13	MCX Connectors
39	SMK Connectors
45	SMA Connectors
103	SMB Connectors
131	SMC Connectors
137	SMP Connectors
145	Type N Connectors
153	Shielded Cable Terminations
157	Between-Series Adapters
161	Fixed Length Cable Assemblies
173	Ultra Miniature Connectors (UMC)
181	kwiQMate™ Connectors
185	Tools
193	Assembly Instructions
257	Electronic Hardware
274	Index

# Specifications

## Electrical Specifications

**Impedance:** 50 Ohms  
**Frequency Range:** 0-6 GHz  
**Attenuation Values:** 1, 2, 3, 6 and 10 dB Nominal\*

**Attenuation Accuracy:**

dB*	0 - 4 GHz	4 - 6 GHz
1-3	±0.3	±0.5
4-6	±0.4	±0.5
7-10	±0.5	±0.5

**VSWR Max:**

dB*	0 - 2.5 GHz	2.5 - 4 GHz	4 - 6 GHz
1-3	1.15 : 1	1.20 : 1	1.25 : 1
4-6	1.15 : 1	1.20 : 1	1.25 : 1
7-10	1.15 : 1	1.25 : 1	1.30 : 1

**Average Input Power:** 2 W Max @ +25°C  
 Derated Linearly to 0.5W at +125°C

\*Other values available, please contact Factory

## Mechanical Specifications

**SMA Connectors:** Per MIL-STD-348A

## Environmental Specifications

**Temperature Range:** -55°C to +125°C  
**Thermal Shock:** MIL-STD-202, Method 107, Condition B except +100°C high temperature)  
**Shock:** MIL-STD-202, Method 213, Condition I  
**Vibration:** MIL-STD-202, Method 204, Condition D

## Material Specifications

**Connector Body:** 303 Stainless Steel per ASTM A582, Passivated per MIL-F-14-72 (EL 300)  
**Coupling Nut:** 303 Stainless Steel per ASTM A582, Passivated per MIL-F-14-72 (EL 300)  
**Retaining Ring:** Beryllium Copper per ASTM B196, Unplated  
**SMA Plug Gasket:** Silicone Rubber per ZZ-R-765  
**Male Contact:** Brass per ASTM B16, Gold Plated per MIL-G-45204 (.00003 min)  
**Female Contact:** Beryllium Copper per ASTM B196, Gold Plated per MIL-G-45204 (.00003 min)  
**Insulators:** PTFE per ASTM D1710  
**Attenuator Card:** Alumina per Mil-I-10, RoHS Compliant Terminals

## SMA Fixed Attenuators Commercial Series



Attenuation (dB Nominal)*	Freq. Range	Stainless Steel Passivated
1	(0-6 GHz)	141-3901-801
2	(0-6 GHz)	141-3901-802
3	(0-6 GHz)	141-3901-803
6	(0-6 GHz)	141-3901-806
10	(0-6 GHz)	141-3901-810

\* Standard values shown. Contact factory for other requirements. Inches (millimeters).

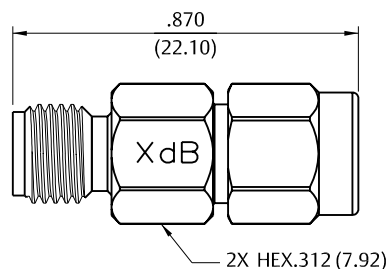

## SMB Connectors

50 Ohm Connectors

Specifications.....	104
Semi-Rigid & Flexible Cable.....	107
PC Mount.....	111
Bulkhead & Panel Mount.....	115
Adapters.....	116
Terminations.....	116

50 Ohm Non-Magnetic Connectors

Specifications.....	117
Semi-Rigid & Flexible Cable.....	118
PC Mount.....	119

75 Ohm Connectors

Specifications.....	120
Semi-Rigid & Flexible Cable.....	123
PC Mount.....	125
Panel Mount.....	127
Terminations.....	129
Adapters.....	130

Other Information

Assembly Tools.....	185
Capabilities.....	190
Cable Information.....	192
Assembly Instruction.....	193
Mounting Hole Layouts.....	194
Numerical Index.....	274
Competitor Cross Reference.....	280

While every precaution has been taken to ensure accuracy and completeness herein, Emerson Network Power Connectivity Solutions assumes no responsibility, and disclaims all liability for damages resulting from use of this information or for any errors or omissions. Specifications subject to change without notice.

## Electrical Specifications

**Impedance:** 50 Ohms**Frequency Range:**

Connectors.....0-4 GHz

Dummy loads.....0-1 GHz

**VSWR:** (max) (f = GHz)

	Straight Cabled Connectors	Right Angle Cabled Connectors
RG-178	1.30 + .04f	1.45 + .06f
RG-316, RG-58, and RG-405	1.25 + .04f	1.35 + .04f
Adapters	1.20 + .04f	
Uncabled receptacles, dummy loads	N/A	

RG-178

RG-316, RG-58, and RG-405

Adapters

Uncabled receptacles, dummy loads..... N/A

**Working Voltage:** (VRMS max)†

	Sea Level	70K Feet
RG-178	250	60
RG-316, RG-58, RG-405, uncabled receptacles, adapters	335	85
Dummy loads	N/A	

RG-178.....250

RG-316, RG-58, RG-405, uncabled receptacles, adapters .....335

Dummy loads..... N/A

**Dielectric Withstanding Voltage:** (VRMS min at sea level)

RG-316 ..... 750

RG-58, RG-142, uncabled receptacles ..... 1000

Dummy loads..... N/A

**Corona Level:** (Volts min at 70,000 feet)†

RG-178 ..... 185

RG-316, RG-58, RG-405 ..... 250

Uncabled receptacles, adapters, dummy loads ..... N/A

**Insertion Loss:** (dB max, tested at 1.5 GHz)

Straight cabled connectors ..... 0.30 dB

Right angle cabled connectors ..... 0.60 dB

Uncabled receptacles, adapters, dummy loads ..... N/A

**Insulation Resistance:** 1000 megohms min**Contact Resistance:** (milliohms max)

	Initial	After Environmental
Center contact (straight cabled connectors and uncabled receptacles)	6.0	8.0
Center contact (right angle cabled connectors and adapters)	12.0	16.0
Outer contact (gold plated connectors)	1.0	1.5
Outer contact (nickel plated connectors)	2.5	3.5
Braid to body (gold plated connectors)	1.0	N/A
Braid to body (nickel plated connectors)	2.5	N/A

Center contact (straight cabled connectors and uncabled receptacles)

Center contact (right angle cabled connectors and adapters)

Outer contact (gold plated connectors)

Outer contact (nickel plated connectors)

Braid to body (gold plated connectors)

Braid to body (nickel plated connectors)

**RF Leakage:** (dB min, tested at 2.5 GHz)

Cabled connectors ..... -55 dB

Uncabled receptacles, adapters, dummy loads ..... N/A

**RF High Potential Withstanding Voltage:**

(VRMS min, tested at 4 and 7 MHz)†

RG-178 ..... 500

RG-316, RG-58 ..... 700

Uncabled receptacles and adapters ..... 600

Dummy loads..... N/A

**Power Rating (Dummy Load):** 0.5 watt @ +25°C, derated to 0.25 watt @ +125° C

## Mechanical Specifications

**Engagement Design:**

MIL-STD-348, Series SMB

**Engagement/Disengagement Force:**

2 lbs min to 14 lbs max axial force

**Contact Retention:**

4 lbs min axial force (captivated contacts)

1 oz-in min torque (uncabled receptacles)

**Cable Retention:**

Axial Force\* (lbs)

Torque (oz-in)

RG-178 ..... 10

RG-316 ..... 20

RG-58 ..... 40

RG-405 ..... 30

\*Or cable breaking strength whichever is less.

**Durability:** 500 cycles min

## Environmental Specifications

(Meets or Exceeds the Applicable Paragraph of MIL-PRF-39012)

**Temperature Range:**

Connectors ..... -65°C to +165°C

Dummy loads ..... -65°C to +125°C

**Thermal Shock:**

MIL-STD-202, Method 107, Condition B (N/A dummy loads)

**Corrosion:**

MIL-STD-202, Method 101, Condition B (N/A dummy loads)

**Shock:**

MIL-STD-202, Method 213, Condition B (N/A dummy loads)

**Vibration:**

MIL-STD-202, Method 204, Condition B (N/A dummy loads)

## Material Specifications

**Bodies:**

Brass per ASTM B16 or zinc per ASTM B86-71, gold plated per MIL-DTL-45204 .00001" min or nickel plated per SAE-AMS2423

**Contacts:**

Male - brass per ASTM B16, gold plated per MIL-DTL-45204 .00003" min

Female - beryllium copper per ASTM B196, gold plated per MIL-DTL-45204 .00003" min

**Insulators:**

PTFE fluorocarbon per ASTM D 1710 and ASTM D 1457 or Teflon PFA 340

**Expansion Caps:**

Brass per ASTM B36, gold plated per MIL-DTL-45204 .00001" min or nickel plated per SAE-AMS2423

**Crimp Sleeves:**

Copper per ASTM B301 or brass per ASTM B16, gold plated per MIL-DTL-45204 .00001" min or nickel plated per SAE-AMS2423

**Mounting Hardware:**

Brass (nuts) per ASTM B16 or phosphor bronze (lockwashers) per ASTM B139, gold plated per MIL-DTL-45204 .00001" min or nickel plated per SAE-AMS2423

**Cover Rings:**

Phosphor Bronze per ASTM B139, gold plated per MIL-DTL-45204 .00001 min or nickel plated per SAE-AMS2423

† Avoid user injury due to misapplication. See safety advisory definitions inside front cover.

Note: All Gold plated parts include a .00005" min Nickel under plated barrier layer.

Mating Engagement for SMB Series

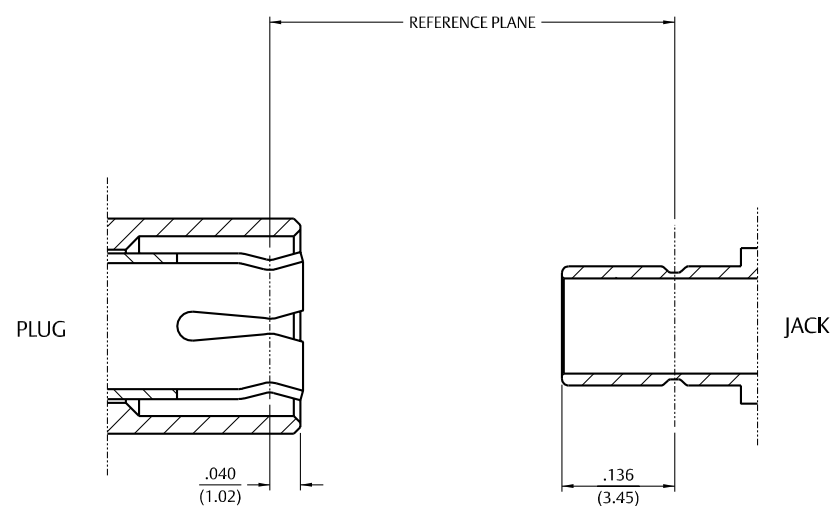
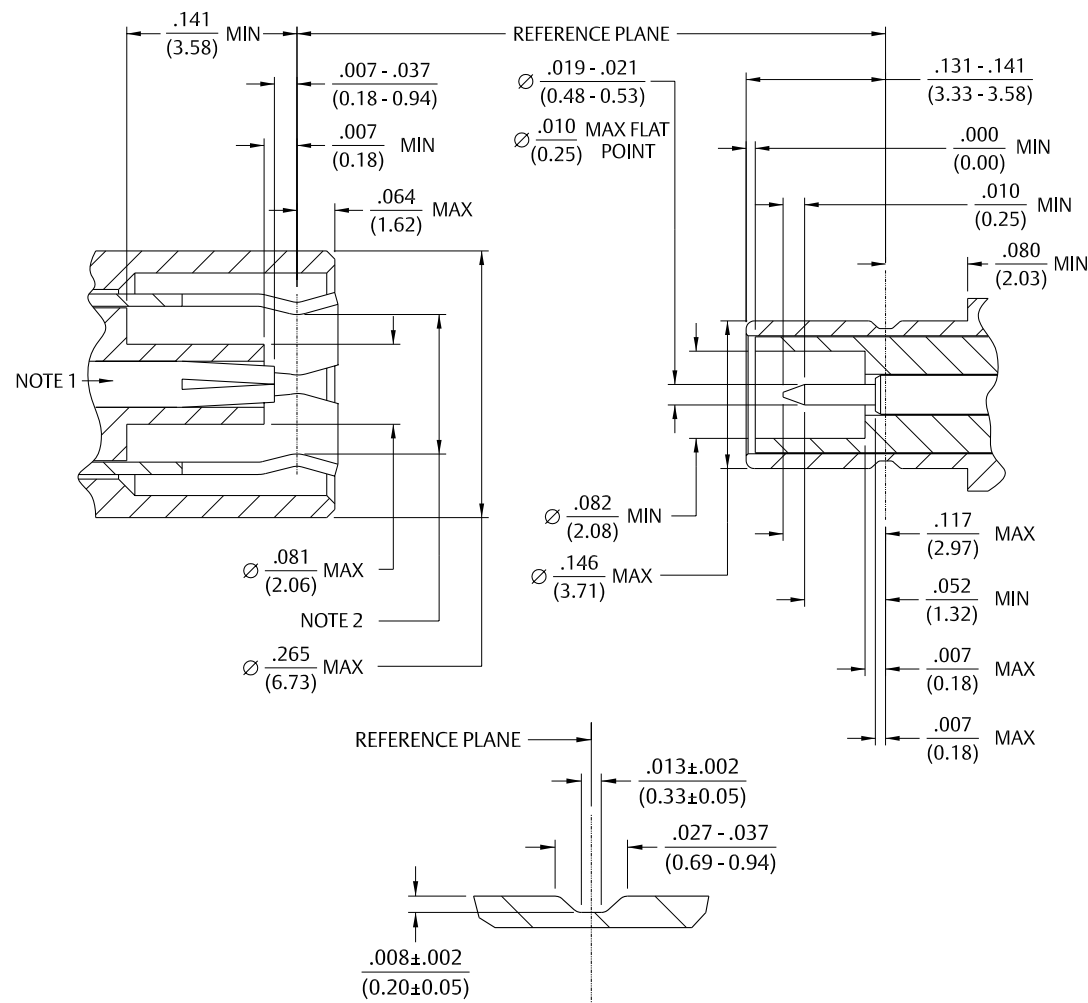

Notes 1. ID of contact to meet VSWR, mating characteristics and connector durability when mated with a dia .019/.021 (0.48/0.53) male contact.  
2. Must meet the force to engage and disengage when mated with mating part.

Straight Solder Type Plug – Captivated Contact

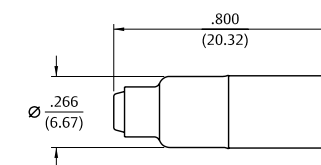

Cable Type	Gold Plated	Nickel Plated
RG-405	131-3693-001	131-3693-016

Assembly instructions page 233.

Straight Solder Type Bulkhead Plug – Captivated Contact

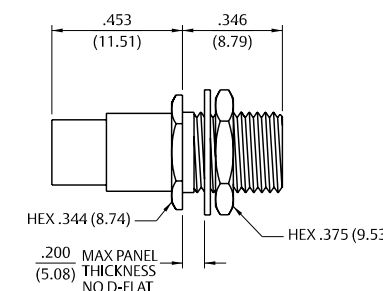

Cable Type	Gold Plated	Nickel Plated
RG-402	131-3694-401	131-3694-406

Assembly instructions page 233.  
Mounting hole dia. .290 (7.05).

Right Angle Solder Type Plug – Captivated Contact

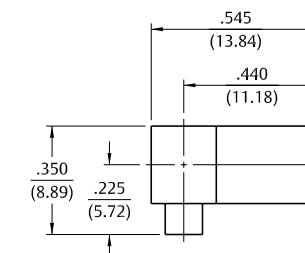

Cable Type	Gold Plated	Nickel Plated
RG-405	131-3693-101	131-3693-116

Assembly instructions page 234.

Straight Bulkhead Solder Type Jack – Captivated Contact

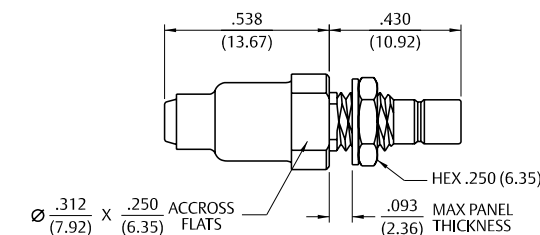

Cable Type	Gold Plated	Nickel Plated
RG-405	131-3593-401	131-3593-406

Assembly instructions page 233.  
Mounting hole layout figure 5 page 194.

## Flexible Cable

## Straight Crimp Type Plug (3-Piece) – Solder or Crimp Captivated Contact

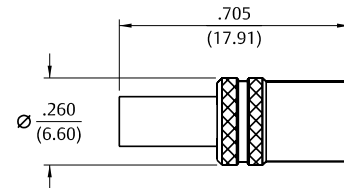

Cable Type	Gold Plated	Nickel Plated
RG-161, 174, 179, 187, 188, 316	131-3403-021	131-3403-026
RG-316 DS, 188 DS, 179 DS, 187 DS	131-3404-021	131-3404-026
RG-58, 141, 303	131-3407-011	131-3407-016

Assembly instructions page 232.

## Straight Solder Type Bulkhead Plug – Solder or Crimp Captivated Contact

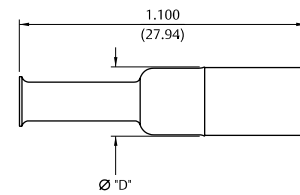

Cable Type	Gold Plated	Nickel Plated	Crimp Contact	"D"
RG-178, 196	131-3402-001	131-3402-016	No	.266 (6.76)
RG-161, 174, 179, 187, 188, 316	131-3403-001	131-3403-016	Yes	.266 (6.76)
RG-316 DS, 188 DS, 179 DS, 187 DS	131-3404-001	131-3404-016	Yes	.266 (6.76)
RG-58, 141, 303	131-3407-001	131-3407-006	Yes	.270 (6.86)

Assembly instructions page 237.

## Straight Crimp Type Plug – Die Cast – Solder or Crimp Captivated Contact

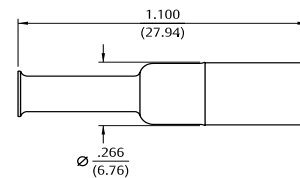

Cable Type	Gold Plated	Nickel Plated
RG-161, 174, 179, 187, 188, 316	131-1403-001	131-1403-016
RG-316 DS, 188 DS, 179 DS, 187 DS	131-1404-001	131-1404-016

Assembly instructions page 237.

## Straight Crimp Type Bulkhead Plug – Solder or Crimp Captivated Contact

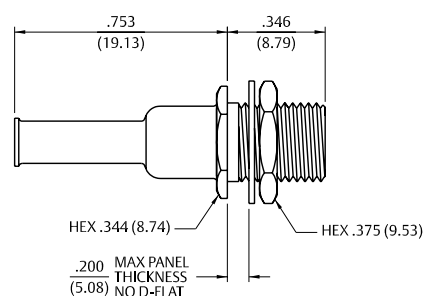

Cable Type	Gold Plated	Nickel Plated
RG-161U, 174, 179, 187, 188, 316	131-3403-401	131-3403-406
RG-316 DS, 188 DS, 179 DS, 187 DS	131-3404-401	131-3404-406

Assembly instructions page 237. Mounting hole dia. .290 (7.05).

## Flexible Cable

109

## Right Angle Crimp Type Plug – Captivated Contact

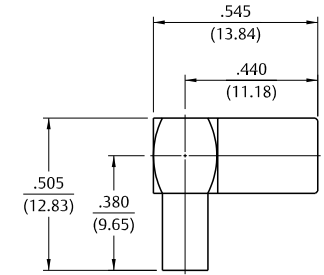

Cable Type	Gold Plated	Nickel Plated
RG-178, 196	131-3402-101	131-3402-116
RG-161, 174, 179, 187, 188, 316	131-3403-101	131-3403-116
RG-316 DS, 188 DS, 179 DS, 187 DS	131-3404-101	131-3404-116

Assembly instructions page 238.

## Right Angle Crimp Type Plug – Captivated Contact

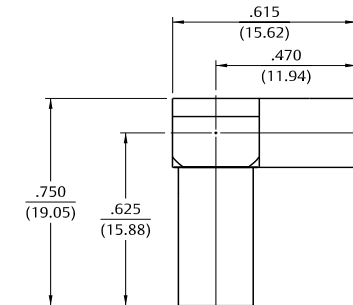

Cable Type	Gold Plated	Nickel Plated
RG-58, 141, 303	131-3407-101	131-3407-106

Assembly instructions page 238.

## Right Angle Crimp Type Plug – Die Cast – Captivated Contact

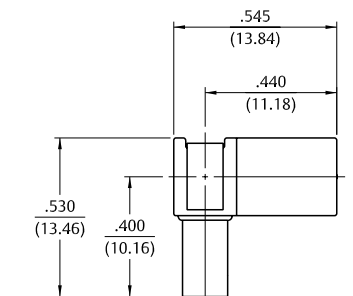

Cable Type	Gold Plated	Nickel Plated
RG-178, 196	131-1402-101	131-1402-116
RG-161, 174, 179, 187, 188, 316	131-1403-101	131-1403-116
RG-316 DS, 188 DS, 179 DS, 187 DS	131-1404-101	131-1404-116

Assembly instructions page 238.

For more information, please contact customer service at (507) 833-8822 or (800) 247-8256 • [www.EmersonConnectivity.com](http://www.EmersonConnectivity.com)

Illustrations are shown in inches (millimeters).

## Flexible Cable

## Straight Crimp Type Jack – Solder or Crimp Captivated Contact

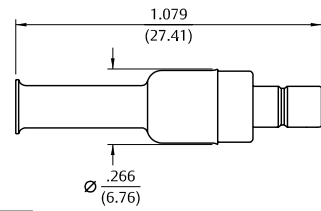

Cable Type	Gold Plated	Nickel Plated	Crimp Contact
RG-178, 196	131-3302-001	131-3302-006	No
RG-161, 174, 179, 187, 188, 316	131-3303-001	131-3303-006	Yes

Assembly instructions page 237.  
Mounting hole layout figure 5 page 194.

## Straight Crimp Type Bulkhead Jack – Solder or Crimp Captivated Contact

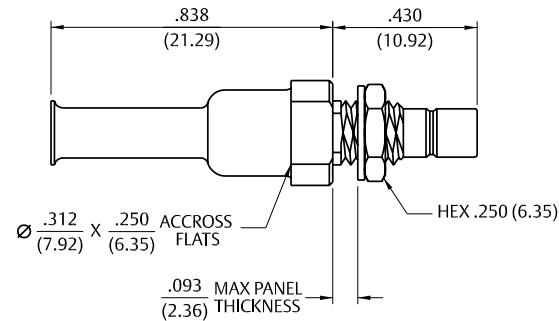

Cable Type	Gold Plated	Nickel Plated
RG-161, 174, 179, 187, 188, 316	131-3303-401	131-3303-406
RG-316 DS, 188 DS, 179 DS, 187 DS	131-3304-401	131-3304-406

Assembly instructions page 237.  
Mounting hole layout figure 5 page 194.

## Right Angle Crimp Type Bulkhead Jack – Captivated Contact

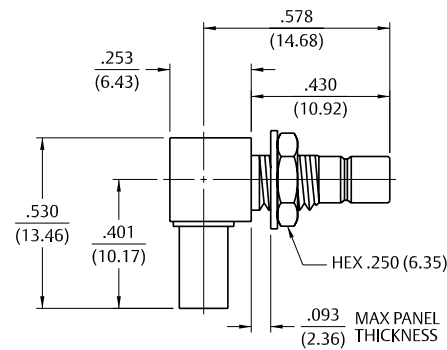

Cable Type	Gold Plated	Nickel Plated
RG-161, 174, 179, 187, 188, 316	131-3303-501	131-3303-506
RG-316 DS, 188 DS, 179 DS, 187 DS	131-3304-501	131-3304-506

Assembly instructions page 238.  
Mounting hole layout figure 5 page 194.

## Straight Plug Receptacle

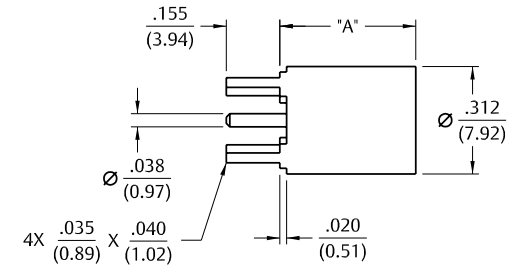

Gold Plated	Nickel Plated	"A"
131-3801-201	131-3801-216	.395 (10.03)
131-3801-231	131-3801-236	.500 (12.70)

Mounting hole layout figure 4 page 194.

## Right Angle Plug Receptacle



Gold Plated	Nickel Plated
131-3801-301	131-3801-316

Mounting hole layout figure 4 page 194.

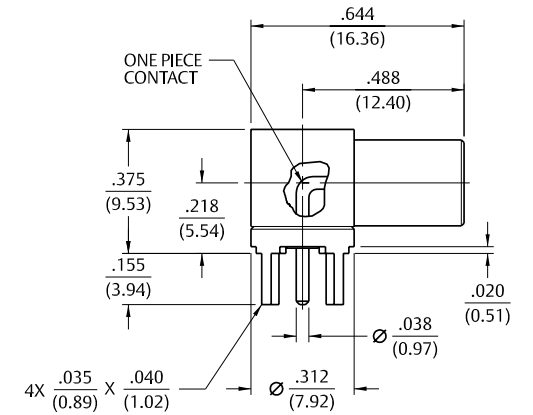

## Right Angle Plug Receptacle – Die Cast



Gold Plated	Nickel Plated
131-1801-371	131-1801-376

Mounting hole layout figure 4 page 194.

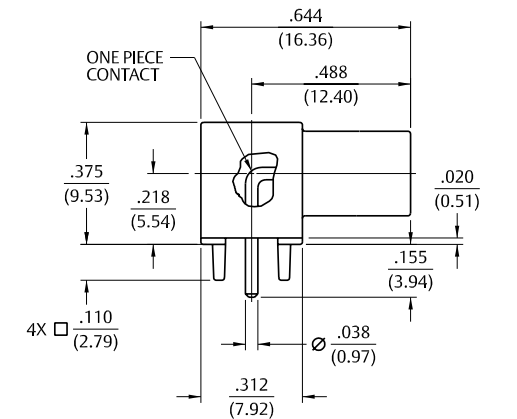



## PC Mount

## Straight Jack Receptacle



Gold Plated	Nickel Plated	"A"
131-3701-201	131-3701-206	.155 (3.94)
131-3701-211	131-3701-216	.110 (2.79)

Mounting hole layout figure 4 page 194.

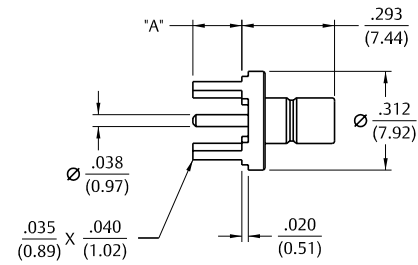

## Straight Jack Receptacle



Gold Plated	Nickel Plated	"A"
131-3701-261	131-3701-266	.155 (3.94)
131-3701-271	131-3701-276	.095 (2.41)

Mounting hole layout figure 4 page 194.

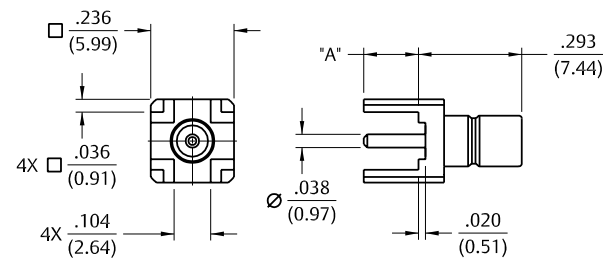

## Straight Bulkhead Jack Receptacle



Gold Plated	Nickel Plated
131-3701-231	131-3701-236

Mounting hole layout figures 4 and 5 page 195.

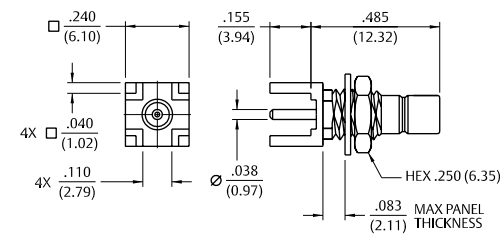

## PC Mount

113

## Straight Jack Receptacle – Surface Mount



Gold Plated

131-3711-201

Recommended Land pattern figure 9 page 194.

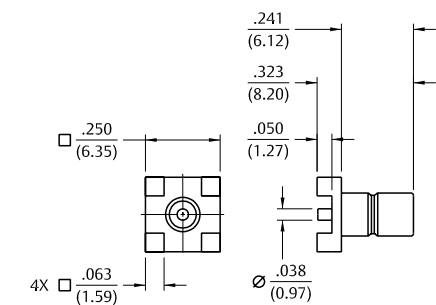

## Right Angle Jack Receptacle



Gold Plated

131-3701-301

Nickel Plated

131-3701-306

Mounting hole layout figure 4 page 194.

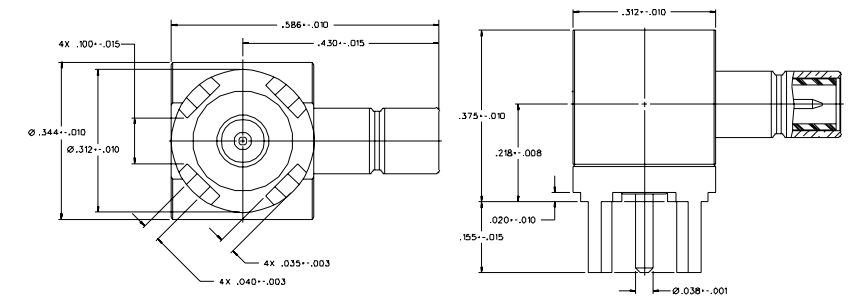

## Right Angle Jack Receptacle – Die Cast



Gold Plated

131-1701-371

Nickel Plated

131-1701-376

Mounting hole layout figure 4 page 194.

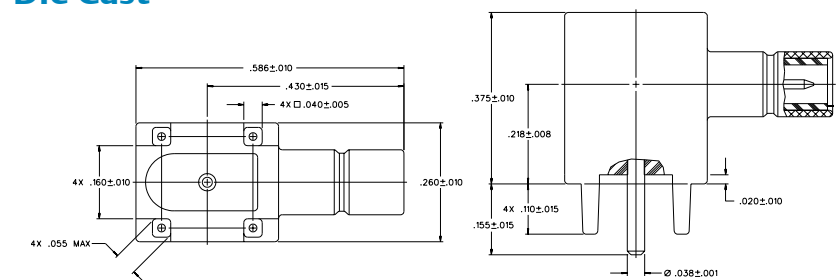

## PC Mount

## Right Angle Surface Mount Jack Receptacle



Gold Plated	Packaging
131-3711-301	Stock
131-3711-302	Tape and Reel, 425 pcs/reel

Mounting hole layout figure 9 page 194.

Tape and Reel .630 (16.0) component pitch .945 (24.0) wide

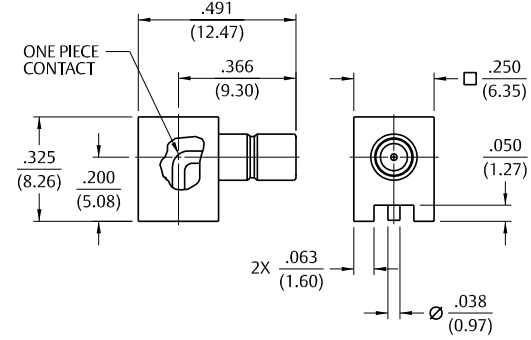

## Right Angle Bulkhead Jack Receptacle



Gold Plated	Nickel Plated	"A"
131-3701-501	131-3701-506	.083 (2.11)
131-3701-511	131-3701-516	.110 (2.79)
131-3701-341	131-3701-346	.155 (3.94)

Mounting hole layout figures 4 and 5 page 194.

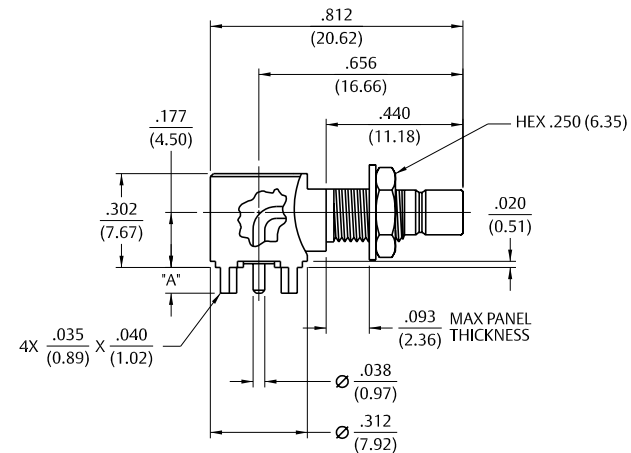

## End Launch Jack Receptacle – Round Contact



Gold Plated	Nickel Plated	Board Thickness	"A"	"B"
131-3701-801	131-3701-806	.062 (1.57)	.068 (1.73)	.073 (1.85)
131-3701-821	131-3701-826	.042 (1.07)	.048 (1.22)	.093 (2.36)

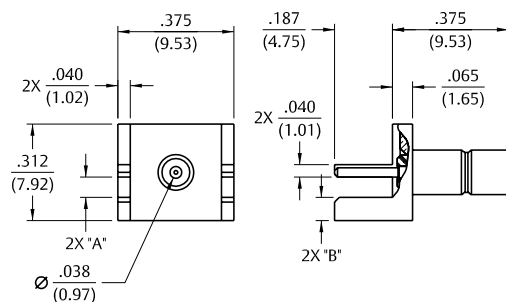

## End Launch Jack Receptacle – Tab Contact



Gold Plated	Nickel Plated	Board Thickness	"A"	"B"
131-3701-811	131-3701-816	.062 (1.57)	.068 (1.73)	.083 (2.11)
131-3701-831	131-3701-836	.042 (1.07)	.048 (1.22)	.103 (2.62)

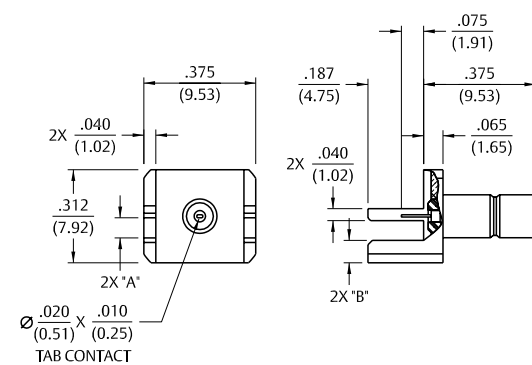

## Bulkhead and Panel Mount

## Front Mount Bulkhead Jack Receptacle



Gold Plated	Nickel Plated
131-3701-411	131-3701-416

Mounting hole layout figure 5 page 194.

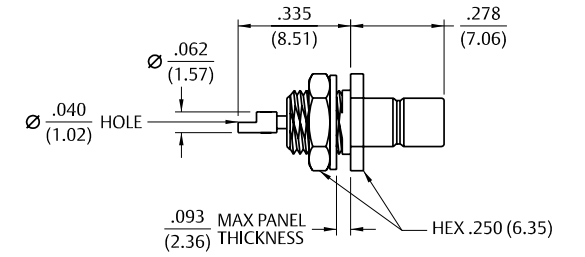

## Rear Mount Bulkhead Jack Receptacle



Gold Plated	Nickel Plated
131-3701-401	131-3701-406

Mounting hole layout figure 5 page 194.

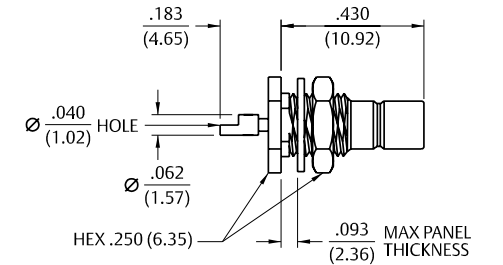

## Front Mount Bulkhead Jack Receptacle – Thread Mount Ruggedized Interface – Round Contact



Gold Plated	Nickel Plated
131-3701-441	131-3701-446

## 2-Hole Flange Mount Jack Receptacle



Gold Plated	Nickel Plated
131-3701-621	131-3701-626

## 4-Hole Flange Mount Jack Receptacle



Gold Plated	Nickel Plated
131-3701-631	131-3701-636

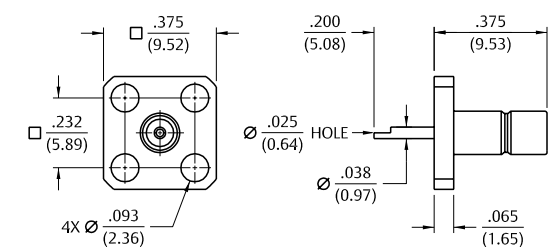
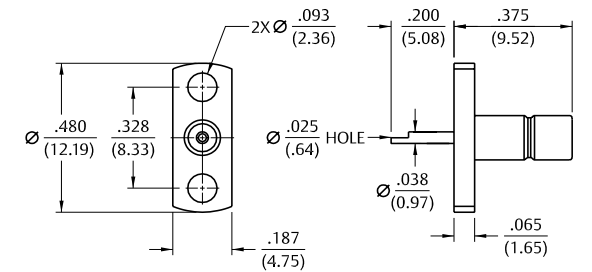
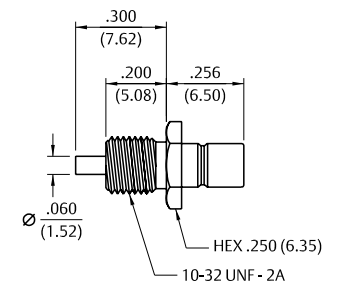

For more information, please contact customer service at (507) 833-8822 or (800) 247-8256 • [www.EmersonConnectivity.com](http://www.EmersonConnectivity.com)

Illustrations are shown in inches (millimeters).

# In-Series Adapters & Terminations

## Jack to Bulkhead Jack Adapter



Gold Plated	Nickel Plated
131-3901-401	131-3901-406

Mounting hole layout figure 5 page 194.

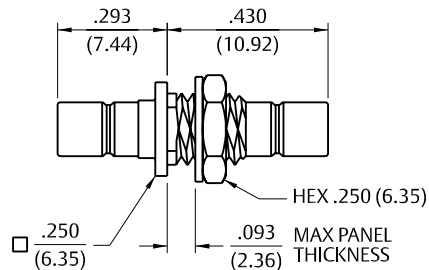

## Plug to Bulkhead Jack Adapter



Gold Plated	Nickel Plated
131-3901-411	131-3901-416

Mounting hole layout figure 5 page 194.

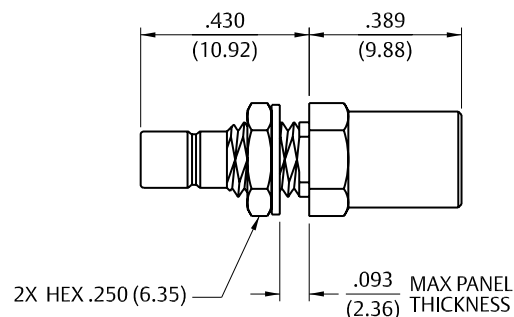

## Plug Dummy Load – 50 Ohm and 75 Ohm



Gold Plated	Nickel Plated	Resistance
131-3801-811	131-3801-816	50 Ohm
131-3801-821	131-3801-826	75 Ohm

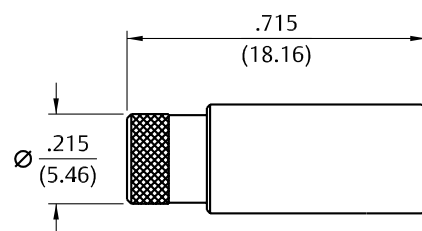

## Electrical Specifications

**Impedance:** 50 Ohms

**Frequency Range:**

Connectors	Straight Cabled Connectors	Right Angle Cabled Connectors
RG-316	1.25 + .04f	1.35 + .04f
Uncabled receptacles	N/A	

**Working Voltage:** (VRMS max)†

	Sea Level	70K Feet
RG-316, uncabled connectors	335	85

**Dielectric Withstanding Voltage:** (VRMS min at sea level)†

RG-316, uncabled receptacles	1000
------------------------------	------

**Corona Level:** (Volts min at 70,000 feet)†

RG-316	250
Uncabled receptacles	N/A

**Insertion Loss:** (dB max, tested at 1.5 GHz)

Straight cabled connectors	0.30 dB
Right angle cabled connectors	0.60 dB
Uncabled receptacles	N/A

**Insulation Resistance:** 1000 megohms min

**Contact Resistance:** (milliohms max)

	Initial	After Environmental
Center contact (straight cabled connectors and uncabled receptacles)	6.0	8.0
Center contact (right angle cabled connectors)	12.0	16.0
Outer contact	1.0	1.5
Braid to body	1.0	N/A

**RF Leakage:** (dB min tested at 2.5 GHz)

Cabled connectors	-55 dB
Uncabled receptacles	N/A

**RF High Potential Withstanding Voltage:** (Vrms min, tested at 4 and 7 MHz)†

Connectors for RG-316	700
Uncabled receptacles	600

## Mechanical Specifications

**Engagement Design:**

MIL-STD-348, Series SMB

**Engagement/Disengagement Force:**

2 pounds min to 14 pounds max axial force

**Contact Retention:**

4 lbs. min axial force (captivated contacts)

1 inch-ounce min torque (uncabled receptacles)

**Cable Retention:**

RG-316	Axial Force* (lbs)	Torque (oz-in)
	20	N/A

\*or cable breaking strength whichever is less.

**Durability:** 500 cycles min

## Environmental Specifications

(Meets or Exceeds the Applicable Paragraph of MIL-PRF-39012)

**Temperature Range:** - 65°C to + 165°C

**Thermal Shock:** MIL-STD-202, Method 107, Condition B

**Corrosion:** MIL-STD-202, Method 101, Condition B

**Shock:** MIL-STD-202, Method 213, Condition B

**Vibration:** MIL-STD-202, Method 204, Condition B

\* See Non-Magnetic materials specifications page X.

† Avoid user injury due to misapplication. See safety advisory definitions inside front cover.

Refer back to Page 121 for Mating Engagement detail.

## Material Specifications

(See non-magnetic materials page 10)

For more information, please contact customer service at (507) 833-8822 or (800) 247-8256 • www.EmersonConnectivity.com

Illustrations are shown in inches (millimeters).

## Flexible Cable

## Straight Crimp Type Plug – Solder or Crimp Captivated Contact

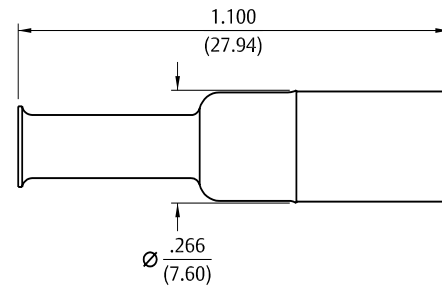

Cable Type	Gold Plated
RG-316, 188, 174, 179, 187	131-9403-001
RG-316 DS, 188 DS, 179 DS, 187 DS	131-9404-001

Assembly instructions page 235.

## Straight Crimp Type Plug (3-piece) Solder or Crimp Captivated Contact

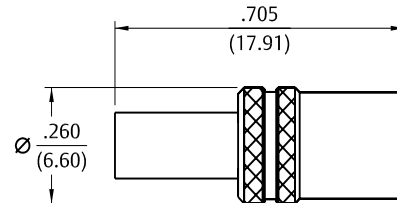

Cable Type	Gold Plated
RG-316, 188, 174, 179, 187	131-9403-021
RG-316 DS, 188 DS, 179 DS, 187 DS	131-9404-021

Assembly instructions page 232.

## Right Angle Crimp Type Plug – Captivated Contact

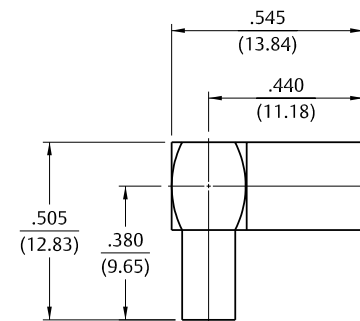

Cable Type	Gold Plated
RG-316, 188, 174, 179, 187	131-9403-101
RG-316 DS, 188 DS, 179 DS, 187 DS	131-9404-101

Assembly instructions page 236.

## PC Mount

119

## Straight Jack Receptacle



Gold Plated	"A"
131-9701-201	.155 (3.94)
131-9701-211	.095 (2.41)

Mounting hole layout figure 4 page 194.

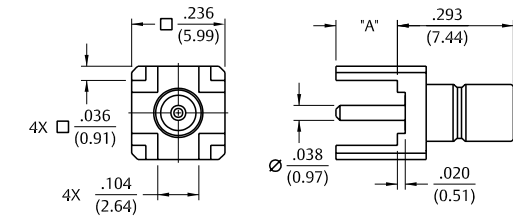

## Right Angle Jack Receptacle



Gold Plated
131-9701-301

Mounting hole layout figure 4 page 194.

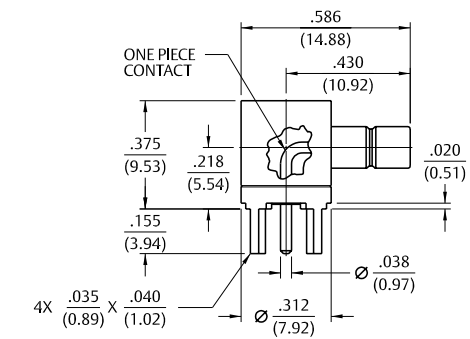

## Specifications

## Electrical Specifications

**Impedance:** 75 Ohms**Frequency Range:** 0-2 GHz**VSWR:** (max) (f = GHz)

RG-179, RG-59, Belden 735A:

Straight cabled connectors.....	1.25 + .04f
Right angle cabled connectors .....	1.35 + .04f
Adapters .....	1.20 + .04f
Type N Adapters .....	1.05 + .01f
Precision loads .....	1.05 + .01f
Uncabled receptacles, opens, shorts.....	N/A

**Working Voltage:** (VRMS max)Sea Level70K Feet

RG-179, RG-59, Belden 735A, uncabled receptacles, adapters.....335 85

Open, shorts, loads.....N/A N/A

**Dielectric Withstanding Voltage:** (Vrms min at sea level)†

RG-179, RG-59, Belden 735A, uncabled receptacles, adapters.....1000

Open, shorts, loads.....N/A

**Insulation Resistance:** 1000 megohms min**Contact Resistance:** (milliohms max)InitialAfter Environmental

Center contact (straight cabled connectors, uncabled receptacles, opens, shorts, loads) .....6.0 8.0

Center contact (right angle cabled connectors and adapters).....12.0 16.0

Outer contact (gold plated connectors).....1.0 1.5

Outer contact (nickel plated connectors).....2.5 3.5

Braid to body (gold plated connectors).....1.0 N/A

**Corona Level:** (Volts min at 70,000 ft)†

RG-179, RG-59, Belden 735A .....250

Uncabled receptacles, adapters, open, shorts, loads.....N/A

**Insertion Loss:** (dB max, tested at 1.5 GHz)

Straight cabled connectors.....0.30 dB

Right angle cabled connectors .....0.60 dB

Uncabled receptacles, adapters, opens, shorts, loads.....N/A

**RF Leakage:** (dB min tested at 2.0 GHz)

Cabled connectors.....-55 dB

Uncabled receptacles, adapters opens, shorts, loads.....N/A

**RF High Potential Withstanding Voltage:**

(VRMS min, tested at 4 and 7 MHz)†

RG-179, RG-59, Belden 735A.....700

Uncabled receptacles and adapters.....600

Opens, shorts, loads .....N/A

**Power Rating:** (Loads) 1.0 watt at +25°C derated linearly to .5 watt at +125°C**Electrical Length:** Open ± 1.5° (±5.2° relative to short)

Short ± 1.5° (±5.2° relative to open)

Adapters ±5.2° (N/A for Jack-Bulkhead Jack and N Types)

## Specifications

121

## Mechanical Specifications

**Engagement Design:** Compatible with MIL-STD-348, Series SMB**Engagement/Disengagement Force:** 2 lbs min to 14 lbs max axial force**Contact Retention:** 4 lbs. min axial force (captivated contacts)

1 oz-in min torque (uncabled receptacles)

**Cable Retention:**Axial Force\* (lbs)Torque (oz-in)

RG-179, Belden 735A .....20 N/A

RG-59 .....40 N/A

\* or cable breaking strength whichever is less.

**Durability:** 500 cycles min

## Environmental Specifications

(Meets or Exceeds the Applicable Paragraph of MIL-PRF-39012)

**Temperature Range:** - 65°C to +165°C - Connectors and adapters, - 65°C to +125°C - Loads, 20°C to 26°C -- Opens, shorts**Thermal Shock:** MIL-STD-202, Method 107, Condition B (N/A opens, shorts, loads)**Corrosion:** MIL-STD-202, Method 101, Condition B (N/A opens, shorts, loads)**Shock:** MIL-STD-202, Method 213, Condition B (N/A opens, shorts, loads)**Vibration:** MIL-STD-202, Method 204, Condition B (N/A opens, shorts, loads)**Temperature Coefficient:** (Loads only) ± 300 ppm/°C

## Material Specifications

**Bodies:** Brass per ASTM B16, gold plated\*\* per MIL-DTL-45204 .00001" min or nickel plated per SAE-AMS2423 N type adapters stainless steel per SAE-AMS QQ-S-763, passivated per MIL-DTL-14072**Contacts:** Male & Female - beryllium copper per ASTM B196, gold plated per MIL-DTL-45204 .00003" min**Insulators:** PTFE fluorocarbon per ASTM D 1710 and ASTM D 1457**Expansion Caps:** Brass per ASTM B36, gold plated per MIL-DTL-45204 .00001" min or nickel plated per SAE-AMS2423**Crimp Sleeves:** Copper per ASTM B301, gold plated per MIL-DTL-45204 .00001" min or nickel plated per SAE-AMS2423**Mounting Hardware:** Brass (nuts) per ASTM B16 or phosphor bronze (lockwashers) per ASTM B139, gold plated per

MIL-DTL-45204 .00001" min or nickel plated per SAE-AMS2423

*Note: All gold plated parts include a .00005" min nickel underplate barrier layer.**† Avoid user injury due to misapplication. See safety advisory definitions inside front cover.*

# Specifications

## Mating Engagement for Mini-75 Ohm SMB Series (Intermatable with Standard 50 Ohm SMB)

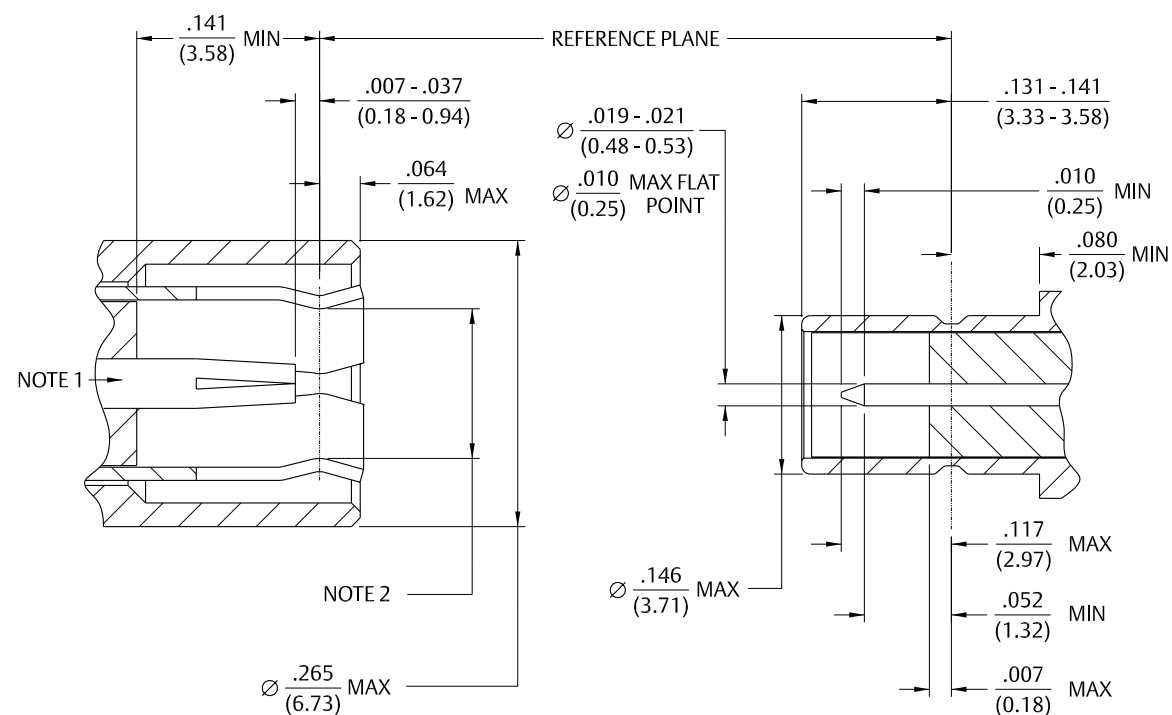

PLUG

JACK

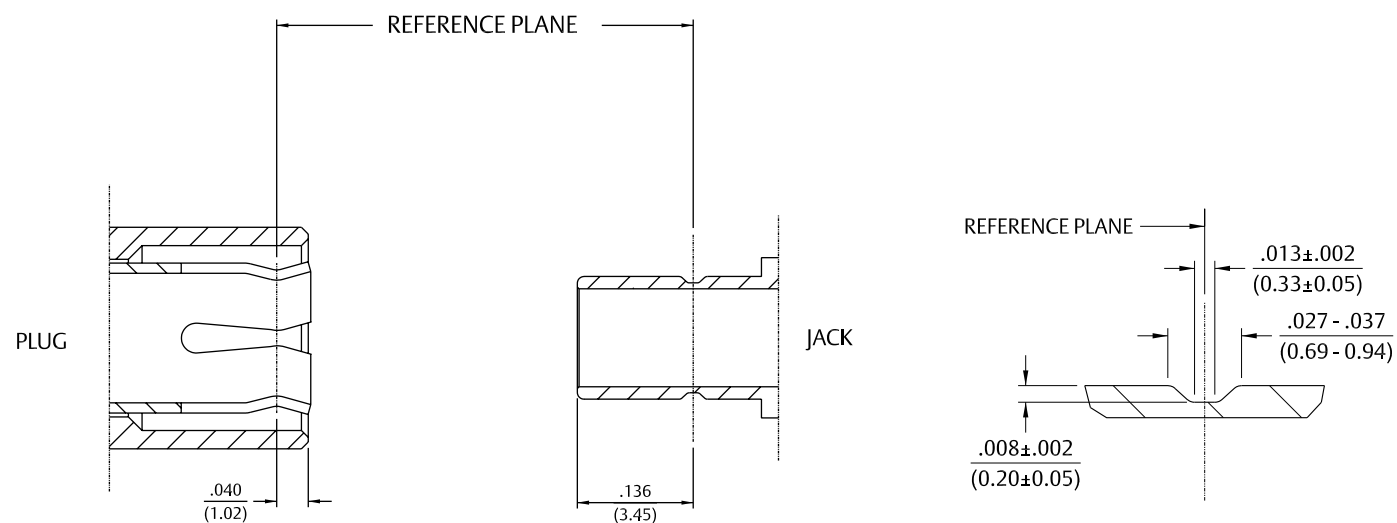

- Notes
1. ID of contact to meet VSWR, mating characteristics and connector durability when mated with a dia .019/.021 (0.48/0.53) male contact.
  2. Must meet the force to engage and disengage when mated with mating part.

## Straight Crimp Type Plug (3-piece) – Solder or Crimp Captivated Contact



Cable Type	Gold Plated	Nickel Plated
RG-179, RG-187	131-8433-001	131-8433-006
RG-179 DS, RG-187 DS	131-8434-001	131-8434-006
Belden 735A	131-8445-011	131-8445-016

Assembly instructions page 232.

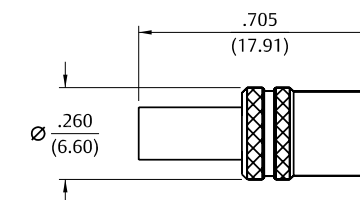

## Straight Crimp Type Plug – Solder or Crimp Captivated Contact



Cable Type	Gold Plated	Nickel Plated	"D"
RG-179, 187	131-8403-001	131-8403-006	.266 (6.76)
RG-179 DS, RG-187 DS	131-8404-001	131-8404-006	.266 (6.76)
Belden 735A	131-8445-001	131-8445-006	.266 (6.76)
RG-59	131-8409-001	131-8409-006	.312 (7.92)

Assembly instructions page 237.

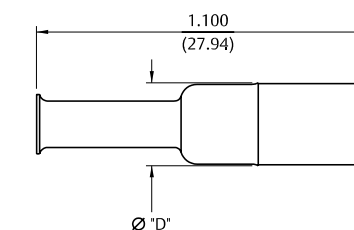

## Straight Crimp Type Plug – Die Cast – Solder or Crimp Captivated Contact



Cable Type	Gold Plated	Nickel Plated
RG-179, 187	131-8403-011	131-8403-016
RG-179 DS, RG-187 DS	131-8404-011	131-8404-016

Assembly instructions page 237.

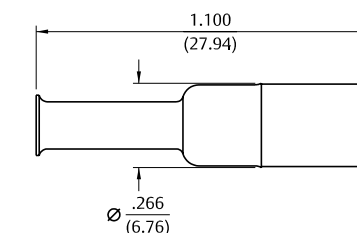

## Straight Crimp Type Bulkhead Jack – Solder or Crimp Captivated Contact



Cable Type	Gold Plated	Nickel Plated
RG-179, 187	131-8303-401	131-8303-406
RG-179 DS, RG-187 DS	131-8304-401	131-8304-406

Assembly instructions page 237.

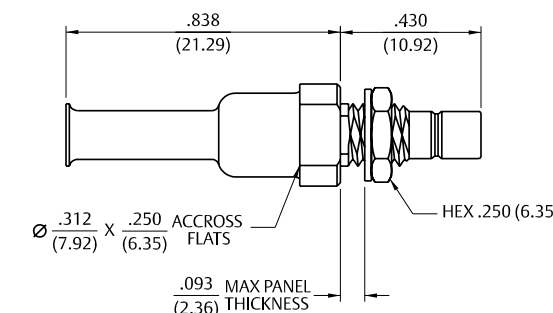

For more information, please contact customer service at (507) 833-8822 or (800) 247-8256 • [www.EmersonConnectivity.com](http://www.EmersonConnectivity.com)

Illustrations are shown in inches (millimeters).

## Flexible Cable

## Right Angle Crimp Type Plug – Captivated Contact



Cable Type	Gold Plated	Nickel Plated	"A"	"B"
RG-179, 187	131-8403-101	131-8403-106	.505 (12.83)	.380 (9.65)
RG-179 DS, RG-187 DS	131-8404-101	131-8404-106	.505 (12.83)	.380 (9.65)
Belden 735A	131-8445-101	131-8445-106	.750 (19.05)	.625 (15.88)

Assembly instructions page 238.

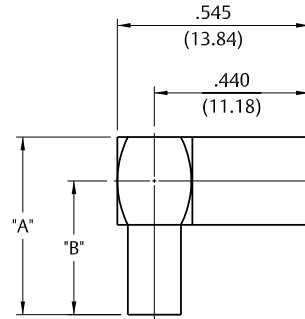

## Right Angle Crimp Type Plug – Captivated Contact



Cable Type	Gold Plated	Nickel Plated
RG-59	131-8409-101	131-8409-106

Assembly instructions page 238.

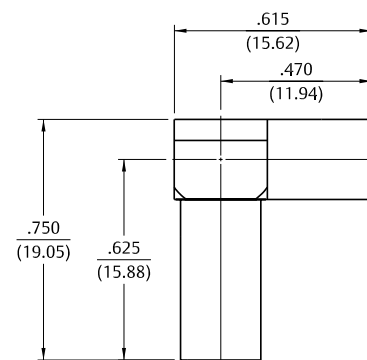

## Right Angle Crimp Type Plug – Captivated Contact – Die Cast



Cable Type	Gold Plated	Nickel Plated
RG-179, 187	131-8403-111	131-8403-116
RG-179 DS, RG-187DS	131-8404-111	131-8404-116

Assembly instructions page 238.

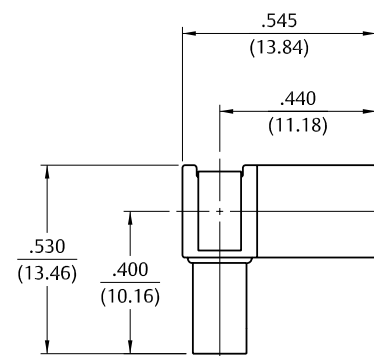

## Straight Jack Receptacle



Gold Plated	Nickel Plated
131-8701-201	131-8701-206

Mounting hole layout figure 6 page 194.

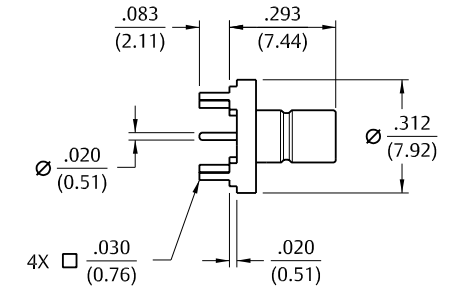

## Straight Jack Receptacle



Cable Type	Gold Plated	"A"
131-8701-251	131-8701-256	.155 (3.94)
131-8701-261	131-8701-266	.095 (2.41)

Mounting hole layout figure 6 page 194.

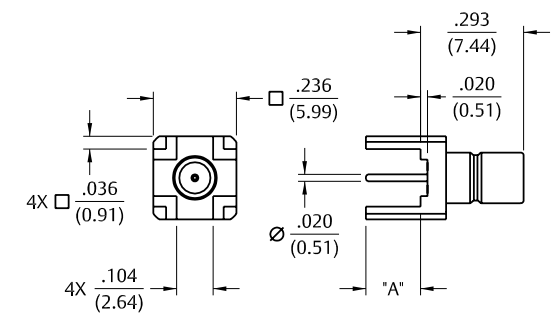

## Straight Bulkhead Jack Receptacle



Gold Plated	Nickel Plated
131-8701-211	131-8701-216

Mounting hole layout figures 5 and 6 page 195.

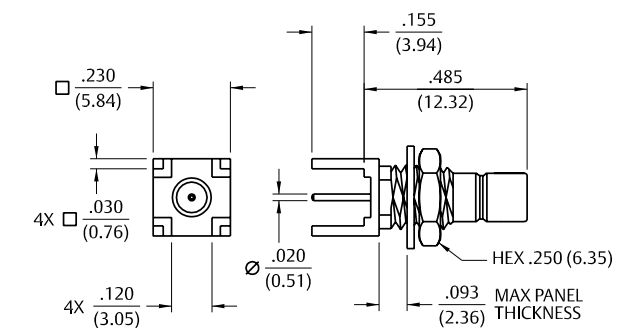

## PC Mount

## Straight Jack Receptacle – Surface Mount



Gold Plated	Packaging
131-8711-201	Stock
131-8711-202	Tape and Reel 750 pcs/reel

Mounting hole layout figure 11 page 194.

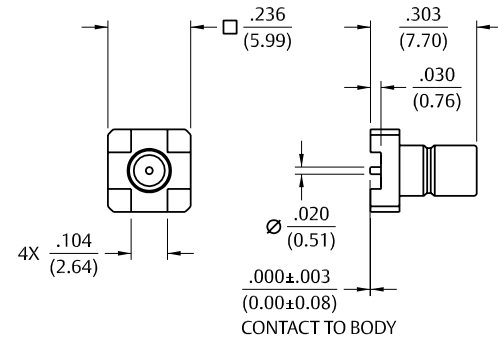

## Right Angle Jack Receptacle



Gold Plated	Nickel Plated	"A"
131-8701-301	131-8701-306	.083
131-8701-311	131-8701-316	.125

Mounting hole layout figure 7 page 194.

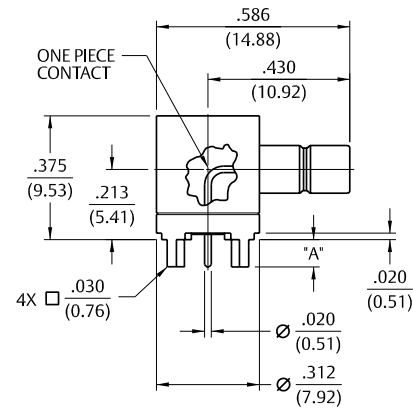

## Right Angle Bulkhead Jack Receptacle



Gold Plated	Nickel Plated
131-8701-501	131-8701-506

Mounting hole layout figures 5 and 7 page 194.

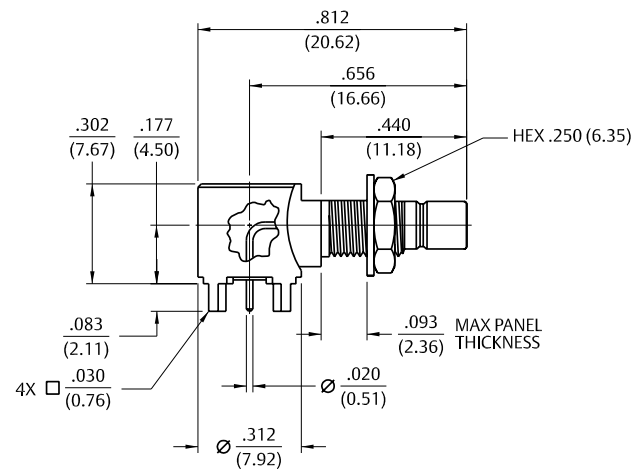

## PC Mount &amp; Panel Mount

127

## End Launch Jack Receptacle

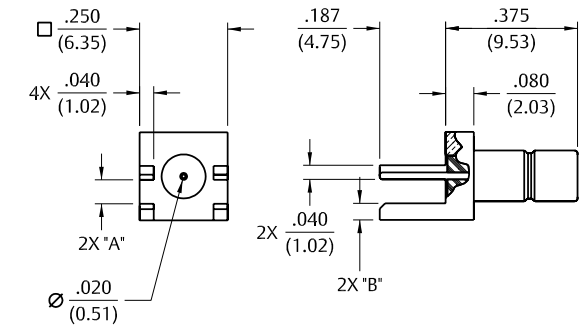

Gold Plated	Nickel Plated	Board Thickness	"A"	"B"
131-8701-841	131-8701-846	.062 (1.57)	.068 (1.73)	.047 (1.19)

## 2-Hole Flange Mount Jack Receptacle



Gold Plated	Nickel Plated
131-8701-601	131-8701-606

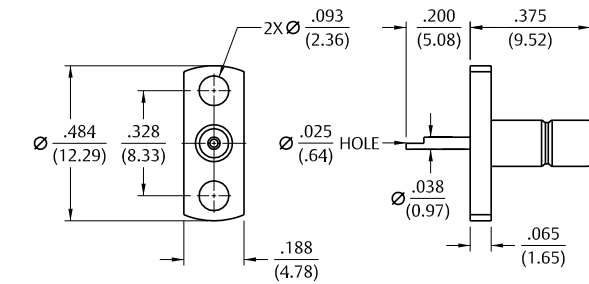

For more information, please contact customer service at (507) 833-8822 or (800) 247-8256 • [www.EmersonConnectivity.com](http://www.EmersonConnectivity.com)

Illustrations are shown in inches (millimeters).



## Terminations

### Plug Precision Load



Gold Plated  
131-8801-801

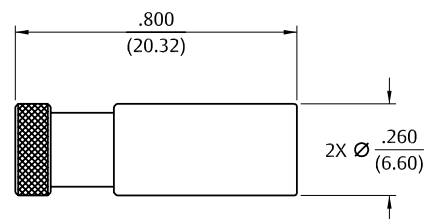

### Matched Plug Open and Short



Type	Gold Plated
OPEN	131-8801-821
SHORT	131-8801-811

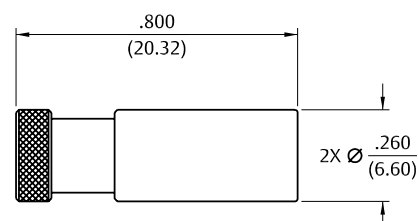

### Matched Jack Open and Short



Type	Gold Plated
OPEN	131-8701-821
SHORT	131-8701-811

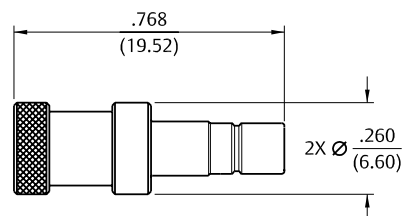

### Jack to Jack Adapter



Gold Plated  
131-8901-801

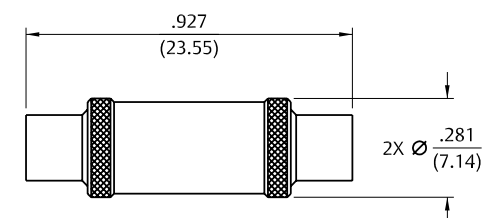

### Plug to Plug Adapter



Gold Plated  
131-8901-811

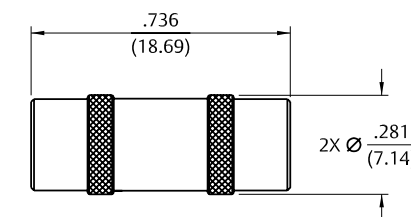

### Jack to Plug Adapter



Gold Plated  
131-8901-821

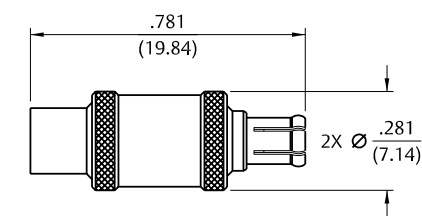

### Jack to Bulkhead Jack\* Adapter



Gold Plated	Nickel Plated
131-8901-401	131-8901-406

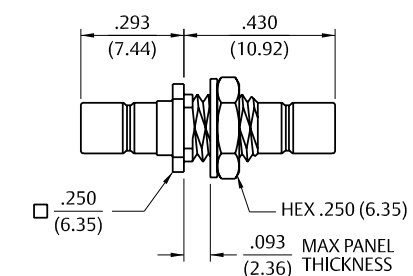

Mounting hole layout figure 5 page 194. \* Electrical length not matched to other adapters shown.

## In-Series Matched Adapters

## Between-Series Adapter

### 75 Ohm Type N Plug to Mini-75 Ohm SMB Plug Adapter



Stainless Steel Passivated

134-1069-001

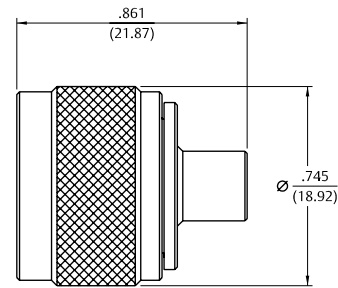

### 75 Ohm Type N Plug to Mini-75 Ohm SMB Jack Adapter



Stainless Steel Passivated

134-1069-011

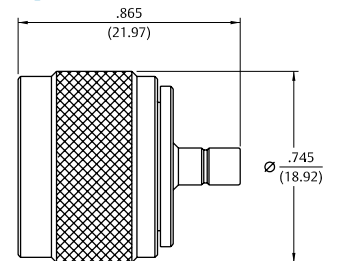

### 75 Ohm Type N Jack to Mini-75 SMB Plug Adapter



Stainless Steel Passivated

134-1069-021

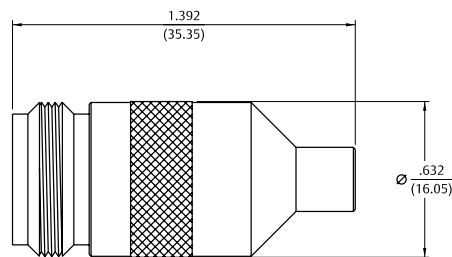

### 75 Ohm Type N Plug to Mini-75 Ohm SMB Jack Adapter



Stainless Steel Passivated

134-1069-031

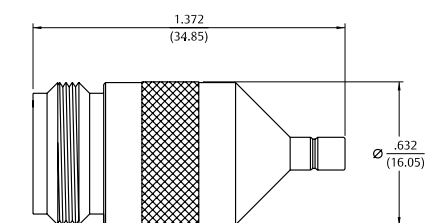

## SMC Connectors

50 Ohm Connectors	
Specifications.....	132
Semi-Rigid & Flexible Cable.....	134
PC Mount.....	135
Bulkhead & Panel Mount.....	136

Other Information	
Assembly Tools.....	185
Capabilities.....	190
Cable Information.....	192
Assembly Instruction.....	193
Mounting Hole Layouts.....	194
Numerical Index.....	274
Competitor Cross Reference.....	280

3	MMCX Connectors
13	MCX Connectors
39	SMK Connectors
45	SMA Connectors
103	SMB Connectors
131	<b>SMC Connectors</b>
137	SMP Connectors
145	Type N Connectors
153	Shielded Cable Terminations
157	Between-Series Adapters
161	Fixed Length Cable Assemblies
173	Ultra Miniature Connectors (UMC)
181	kwiQMate™ Connectors
185	Tools
193	Assembly Instructions
257	Electronic Hardware
274	Index

While every precaution has been taken to ensure accuracy and completeness herein, Emerson Network Power Connectivity Solutions assumes no responsibility, and disclaims all liability for damages resulting from use of this information or for any errors or omissions. Specifications subject to change without notice.

# Specifications

## Electrical Specifications

<b>Impedance:</b> 50 Ohms		
<b>Frequency Range:</b> .....		0-10 GHz
<b>VSWR:</b> (max) (f = GHz)		
	Straight Cabled Connectors	Right Angle Cabled Connectors
RG-178.....	1.25 + .04f	1.40 + .06f
RG-316 and RG-405 .....	1.20 + .04f	1.30 + .04f
Uncabled receptacles.....	N/A	
<b>Working Voltage:</b> (VRMS max)†	Sea Level	70K Feet
RG-178.....	250	60
RG-316, RG-405 uncabled receptacles .....	335	85
<b>Dielectric Withstanding Voltage:</b> (VRMS min at sea level)†		
RG-178 .....		750
RG-316, RG-405 uncabled receptacles .....		1000
<b>Corona Level:</b> (Volts min at 70,000 feet)†		
RG-178 .....		185
RG-316, RG-405 .....		250
Uncabled receptacles.....		N/A
<b>Insertion Loss:</b> (dB max, tested at 4 GHz)		
Straight cabled connectors.....		0.25 dB
Right angle cabled connectors .....		0.50 dB
Uncabled receptacles .....		N/A
<b>Insulation Resistance:</b> 1000 megohms min		
<b>Contact Resistance:</b> (milliohms max)	Initial	After Environmental
Center contact (straight cabled connectors and uncabled receptacles) .....	6.0	8.0
Center contact (right angle cabled connectors) .....	12.0	16.0
Outer contact (gold plated connectors) .....	1.0	N/A
Outer contact (nickel plated connectors) .....	2.5	N/A
Braid to body (gold plated connectors) .....	1.0	N/A
Braid to body (nickel plated connectors) .....	2.5	N/A
<b>RF Leakage:</b> (dB min tested at 2.5 GHz)		
Cabled connectors .....		-55 dB
Uncabled receptacles .....		N/A
<b>RF High Potential Withstanding Voltage:</b> (VRMS min, tested at 4 and 7 MHz)†		
RG-178.....		500
RG-316.....		700
Uncabled receptacles .....		600

## Mechanical Specifications

<b>Engagement Design:</b>	MIL-STD-348, Series SMC	
<b>Engagement/Disengagement Force:</b>	16 oz-in max torque	
<b>Mating Torque:</b>	35 to 50 oz-in	
<b>Coupling Proof Torque:</b>	100 oz-in min	
<b>Coupling Nut Retention:</b>	35 lbs min	
<b>Contact Retention:</b>	4 lbs min axial force (captivated contacts) 1 oz-in min torque (uncabled receptacles)	
<b>Cable Retention:</b>	Axial Force* (lbs)	Torque (oz-in)
RG-178.....	10	N/A
RG-316.....	20	N/A
RG-405.....	30	16

\* or cable breaking strength whichever is less

**Durability:** 500 cycles min

# Specifications

## Environmental Ratings

Meets or exceeds the applicable paragraph of MIL-PRF-39012

<b>Temperature Range:</b>	-65°C to + 165°C
<b>Thermal Shock:</b>	MIL-STD-202, Method 107, Condition B
<b>Corrosion:</b>	MIL-STD-202, Method 101, Condition B
<b>Shock:</b>	MIL-STD-202, Method 213, Condition C
<b>Vibration:</b>	MIL-STD-202, Method 204, Condition D

## Material Specifications

<b>Bodies:</b>	Brass per ASTM B16, gold plated per MIL-DTL-45204 .00001" min or nickel plated per SAE-AMS2432
<b>Contacts:</b>	Male – Brass per ASTM B16, gold plated per MIL-DTL-45204 .00003" min. Female – Beryllium copper per ASTM B196, gold plated per MIL-DTL-45204 .00003" min.
<b>Nut Retention Spring:</b>	Beryllium copper per ASTM B196, unplated
<b>Insulators:</b>	PTFE fluorocarbon per ASTM D 1710 and ASTM D 1457
<b>Expansion Caps:</b>	Brass per ASTM B36, gold plated per MIL-DTL-45204 .00001" min. or nickel plated per SAE-AMS2423
<b>Crimp Sleeves:</b>	Copper per ASTM B301, gold plated per MIL-DTL-45204 .00001" min. or nickel plated per SAE-AMS2423
<b>Mounting Hardware:</b>	Brass (nuts) per ASTM B16 or phosphor bronze (lockwashers) per ASTM B139, gold plated per MIL-DTL-45204 .00001" min. or nickel plated per SAE-AMS2423

\*\* All Gold plated parts include a .00005" minimum Nickel under plated barrier layer

### Mating Engagement for SMC Series

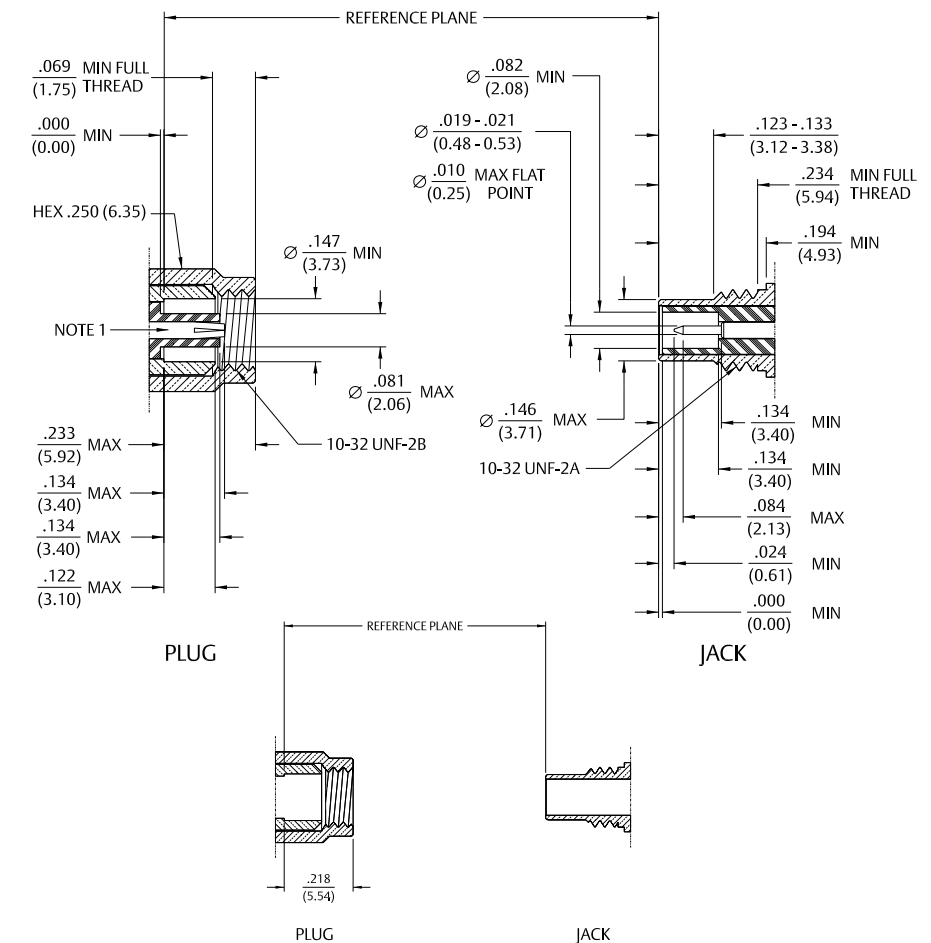

Notes:

1. Inside of contact to meet VSWR mating characteristics and connector durability when mated with a dia. .019/.021 (.48/.53) male contact.

For more information, please contact customer service at (507) 833-8822 or (800) 247-8256 • [www.EmersonConnectivity.com](http://www.EmersonConnectivity.com)

Illustrations are shown in inches (millimeters).

## Semi-Rigid and Flexible Cable

### Straight Solder Type Bulkhead Jack – Captivated Contact

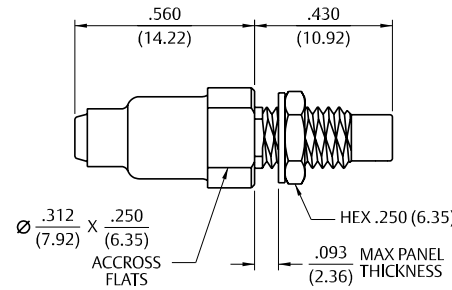

Cable Type	Gold Plated	Nickel Plated
RG-405	131-6593-401	131-6593-406

Assembly instructions page 233.  
Mounting hole layout figure 5 page 194.

### Straight Crimp Type Plug – Captivated Contact

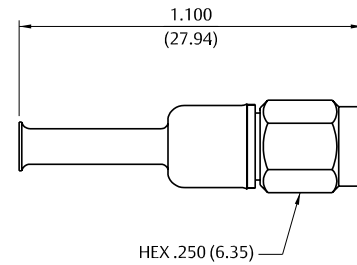

Cable Type	Gold Plated	Nickel Plated
RG-161, 174, 188, 316	131-6403-001	131-6403-006
RG-316 DS, 188 DS	131-6404-001	131-6404-006
RG-179, 187	131-6433-001	131-6433-006

Assembly instructions page 237.

### Right Angle Crimp Type Plug – Captivated Contact

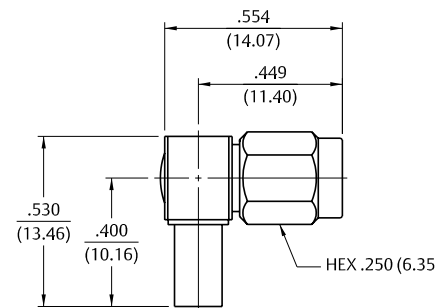

Cable Type	Gold Plated	Nickel Plated
RG-161, 174, 188, 316	131-6403-101	131-6403-106
RG-316 DS, 188 DS	131-6404-101	131-6404-106
RG-179, 187	131-6433-101	131-6433-106

Assembly instructions page 238.

### Straight Crimp Type Bulkhead Jack – Captivated Contact

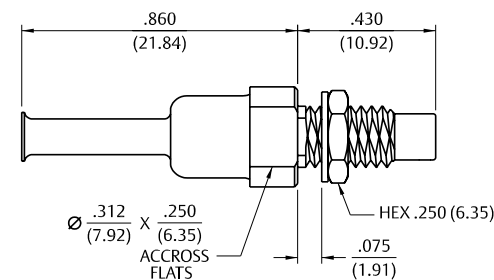

Cable Type	Gold Plated	Nickel Plated
RG-161, 174, 188, 316	131-6303-401	131-6303-406
RG-316 DS, 188 DS	131-6304-401	131-6304-406
RG-179, 187	131-6333-401	131-6333-406

Assembly instructions page 237.  
Mounting hole layout figure 5 page 194.

### Straight Jack Receptacle



Gold Plated	Nickel Plated	"A"
131-6701-201	131-6701-206	.155 (3.94)
131-6701-211	131-6701-216	.110 (2.79)

Mounting hole layout figure 4 page 194.

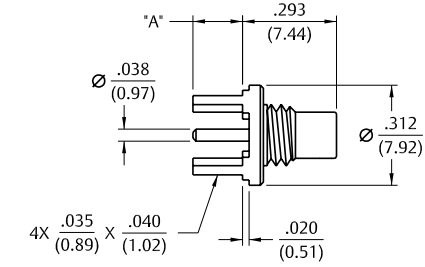

### Straight Jack Receptacle – Surface Mount



Gold Plated
131-6711-201

Mounting hole layout figure 7 page 194.

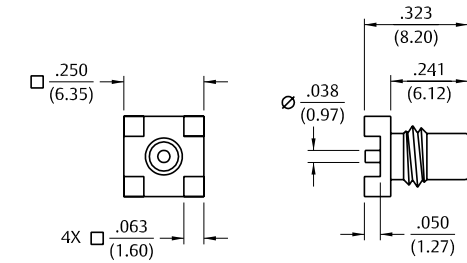

### Right Angle Jack Receptacle



Gold Plated
131-6701-301

Mounting hole layout figure 4 page 194.

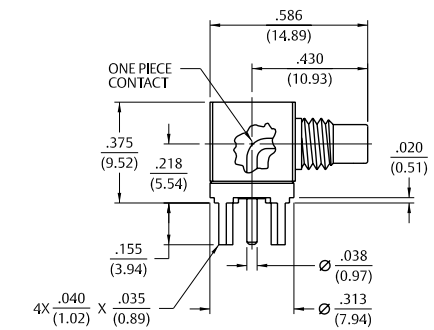

## PC Mount and Bulkhead Mount

### End Launch Jack Receptacle – Tab Contact



Gold Plated	Nickel Plated	Board Thickness
131-6701-831	131-6701-836	.062 (1.57)

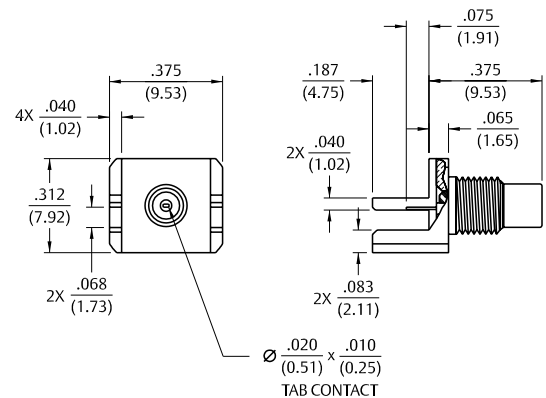

### Front Mount Bulkhead Jack Receptacle



Gold Plated	Nickel Plated
131-6701-411	131-6701-416

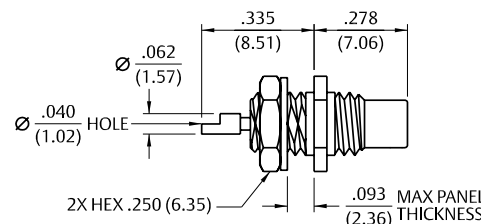

### Rear Mount Bulkhead Jack Receptacle



Gold Plated	Nickel Plated
131-6701-401	131-6701-406

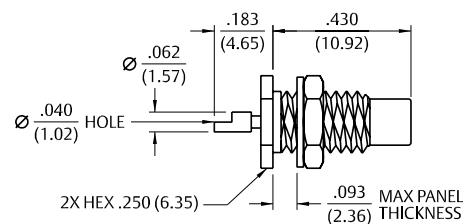

Mounting hole layout figure 5 page 194.

### SMP Connectors

50 Ohm Connectors  
 Specifications..... 139  
 Semi-Rigid & Flexible Cable..... 142  
 PC Mount ..... 142  
 Bulkhead & Panel Mount ..... 143

Other Information  
 Assembly Tools ..... 185  
 Capabilities ..... 190  
 Cable Information ..... 192  
 Assembly Instruction ..... 193  
 Mounting Hole Layouts..... 194  
 Numerical Index..... 274  
 Competitor Cross Reference ..... 280

3	MMCX Connectors
13	MCX Connectors
39	SMK Connectors
45	SMA Connectors
103	SMB Connectors
131	SMC Connectors
137	SMP Connectors
145	Type N Connectors
153	Shielded Cable Terminations
157	Between-Series Adapters
161	Fixed Length Cable Assemblies
173	Ultra Miniature Connectors (UMC)
181	kwiQMate™ Connectors
185	Tools
193	Assembly Instructions
257	Electronic Hardware
274	Index

While every precaution has been taken to ensure accuracy and completeness herein, Emerson Network Power Connectivity Solutions assumes no responsibility, and disclaims all liability for damages resulting from use of this information or for any errors or omissions. Specifications subject to change without notice.

# Introduction

## Description

One of the key benefits of the SMP connector interface is its use in high frequency blind-mate applications. The design of the SMP bullet and shroud system allows for both axial and radial misalignment. The basic system is comprised of an inner “bullet” adapter, and two outer receptacles called “shrouds”. The bullet provides a flexible link between the shroud connections.

In blind-mate applications, one shroud connector will be typically specified as a snap-on interface and the other as a slide-on. This ensures that the bullet adapter remains fixed in the same shroud connector when the connection is disengaged.

The two snap-on interfaces Full Detent (FD) and Limited Detent (LD) each have different engage and disengage coupling forces. The LD is typically selected as the snap-on interface in PCB mount or blind-mate applications, while the FD is mainly used for cabled connections where higher retention forces are required.

The two slide-on interfaces Smooth Bore (SB) and Catcher’s Mitt (CM) allow for reduced connection forces as compared to the snap-on versions. The push-on interface creates a sliding connection that does not physically locate the mating reference planes, allowing for axial and radial misalignment. Both the SB and CM have the same engage/disengage forces; however the CM is typically specified as the shroud configuration in blind-mate applications as its generous lead-in chamfer helps capture and guide the bullet into place.

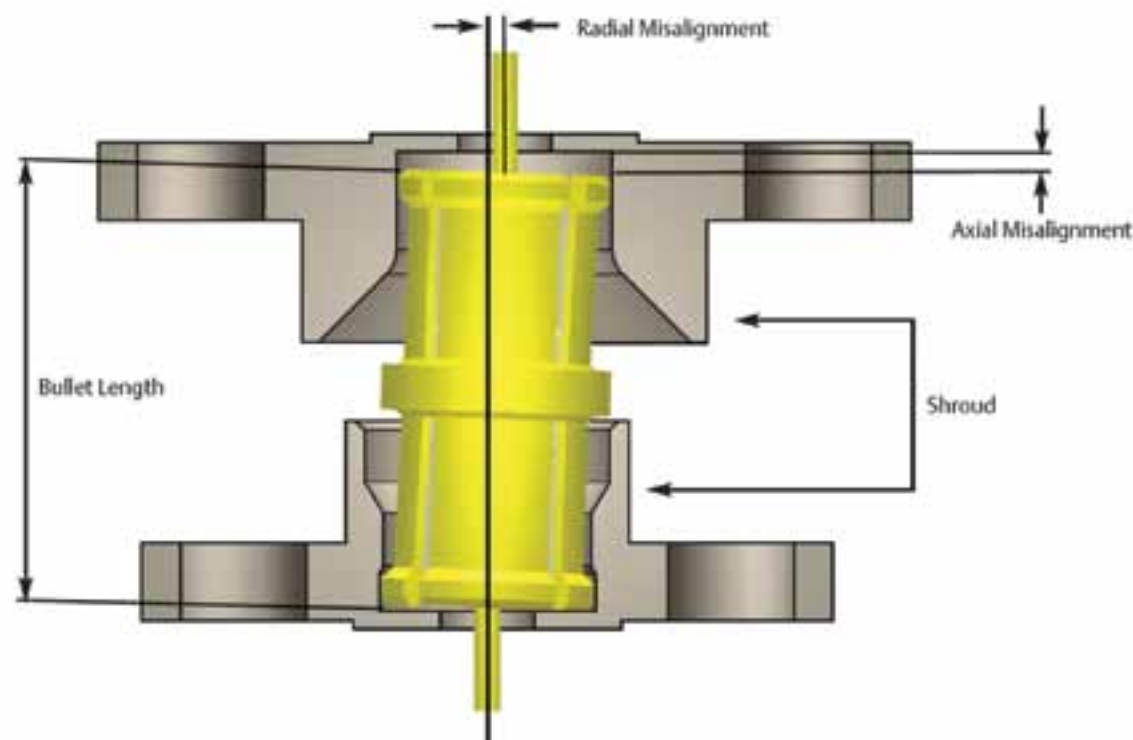

# Specifications

## Electrical Specifications

**Impedance:** 50 Ohms

**Frequency Range:**

Bullet Adapter (.254 length), Semi-Rigid Straight Cabled Connectors	0-40 GHz			
All other In-Series Adapters, Semi-Rigid Right Angle Cabled Connectors, Field Replaceable Connectors, End Launch Connectors, Hermetic Feedthroughs	0-18 GHz			
PC Mount Connectors	0-12 GHz			
<b>VSWR:</b> (max) (f = GHz)	<u>0-18 GHz</u>	<u>18-23 GHz</u>	<u>23-26.5 GHz</u>	<u>26.5-40 GHz</u>
Bullet Adapter (.254 length)	1.10	1.15	1.30	1.70
Semi-Rigid Straight Cabled Connectors		<u>0-18 GHz</u>	<u>18-26.5 GHz</u>	<u>26.5-40 GHz</u>
		1.20	1.35	1.70
All other In-Series Adapters		<u>0-4 GHz</u>	<u>4-12 GHz</u>	<u>12-18 GHz</u>
		1.10	1.15	1.20
Semi-Rigid Right Angle Cabled Connectors				<u>0-18 GHz</u>
				1.20
Field Replaceable Connectors (typical, measured back to back with seal pin)				1.15
Un-cabled Connectors (dependant on application)				N/A

**Working Voltage:** 335 VRMS max at sea level, 65 VRMS max at 70,000 feet

**Dielectric Withstanding Voltage:** 500 Vrms min at sea level

**Insulation Resistance:** 5000 megohms min

**Contact Resistance:** (milliohms max initial, not applicable after environmental testing)

Center Contact (Connectors and Adapters)	6.0
Outer Contact (Connectors and Adapters)	2.0
Cable Shield to Body (Semi-Rigid Cabled Connectors Only)	0.5

**Corona Level:** 190 VRMS min at 70,000 feet

**Insertion Loss:** (dB max)

**Insertion Loss:** (dB max, tested at 10 GHz)

In-Series Adapters, Field Replaceable Connectors	$0.10\sqrt{f(\text{GHz})}$
Semi-Rigid Cabled Connectors	$0.12\sqrt{f(\text{GHz})}$
All other Un-cabled Connectors	N/A

**Insertion Loss:** (dB max)

**RF Leakage:** (dB typical, tested at 2.5 GHz)

Cabled and Field Replaceable Connectors	-80
In-Series Adapters	-65
All other Un-cabled Connectors	N/A

**RF High Potential Withstanding Voltage:** 325 VRMS min at sea level, tested at 4 and 7 MHz

## Mechanical Specifications

**Interface Design:** MIL-STD-348A, Series SMP

**Engagement Force:** (lbs max, mated pair)

Full Detent (FD)	15.0
Limited Detent (LD)	10.0
Smooth Bore and Catcher’s Mitt (SB and CM)	2.0
<b>Disengagement Force:</b> (lbs min, mated pair)	
Full Detent (FD)	5.0
Limited Detent (LD)	2.0
Smooth Bore and Catcher’s Mitt (SB and CM)	0.5

**Mated Radial Misalignment:** (in max allowed, female adapters only)

Between Centerlines of Mating Planes (FD, LD, SB)	.010
Between Centerlines of Mating Planes (CM only)	.020

**Mated Axial Misalignment:** .010 in max allowed between mating planes (female adapters only)

**Durability:** (mating cycles min)

Full Detent (all female connectors and adapters)	100
Limited Detent (female adapters only)	500
Smooth Bore and Catcher’s Mitt (female adapters only)	1000

**Contact Retention:** 1.5 lbs min axial force (captivated contacts only)

<b>Cable Retention:</b> (min)	<b>Axial Force* (lbs)</b>	<b>Torque (oz-in)</b>
Cabled Connectors for RG-405	30	16.0
Cabled Connectors for M17/151	20	N/A

\* Or cable breaking strength, whichever is less

For more information, please contact customer service at (507) 833-8822 or (800) 247-8256 • [www.EmersonConnectivity.com](http://www.EmersonConnectivity.com)

Illustrations are shown in inches (millimeters).

# Specifications

## Environmental Ratings

(Meets or exceeds the applicable paragraph of MIL-PRF-39012)

- Operating Temperature:** -65°C to +165°C
- Thermal Shock:** MIL-STD-202, Method 107, Condition B (except high temp +165°C or max high temp of cable)
- Corrosion:** MIL-STD-202, Method 101, Condition B
- Shock (specified pulse):** MIL-STD-202, Method 213, Condition I
- Vibration:** MIL-STD-202, Method 204, Condition D
- Moisture Resistance:** MIL-STD-202, Method 106 (except step 7b omitted)

## Material Specifications

- Spring Finger (female) and End Launch (male) Bodies:** Beryllium Copper per ASTM B196, Gold plated\* per MIL-DTL-45204 (.00005" min)
- Hermetic Seal Bodies (male):** Kovar Alloy per ASTM F15, Gold plated\* per MIL-DTL-45204 (.00005" min)
- All other Shroud Bodies (male):** Stainless Steel, Type 303, per ASTM A582, Passivated per MIL-DTL-14072 (EL 300)
- Connector and Adapter Contacts (male and female):** Beryllium Copper per ASTM B196, Gold plated\* per MIL-DTL-45204 (.00005" min)
- Hermetic Seal Center Pins:** Kovar Alloy per ASTM F15, Gold plated\* per MIL-DTL-45204 (.00005" min)
- EMI/Anti-Rock Rings:** Beryllium Copper per ASTM B196, Gold plated\* per MIL-DTL-45204 (.00003" min)
- PC Mount Legs:** Brass per ASTM B16, Gold plated\* per MIL-DTL-45204 (.00003" min)
- Connector and Adapter Insulators:** PTFE per ASTM D1710
- Hermetic Seal Glass:** Corning 7070

\* All Gold plated parts include a .00005" minimum Nickel barrier layer

**Typical Measured Return Loss  
Bullet Adapter 127-0901-801**

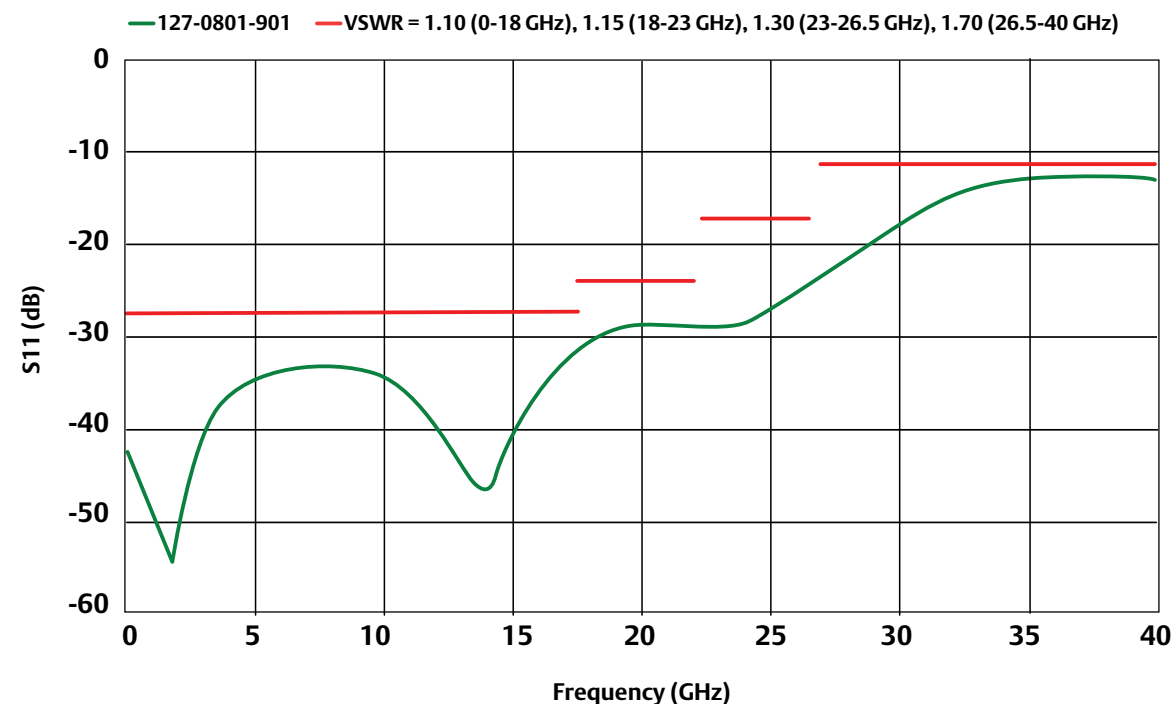

# Specifications

## Mating Engagement for SMP Series per MIL-STD-348A

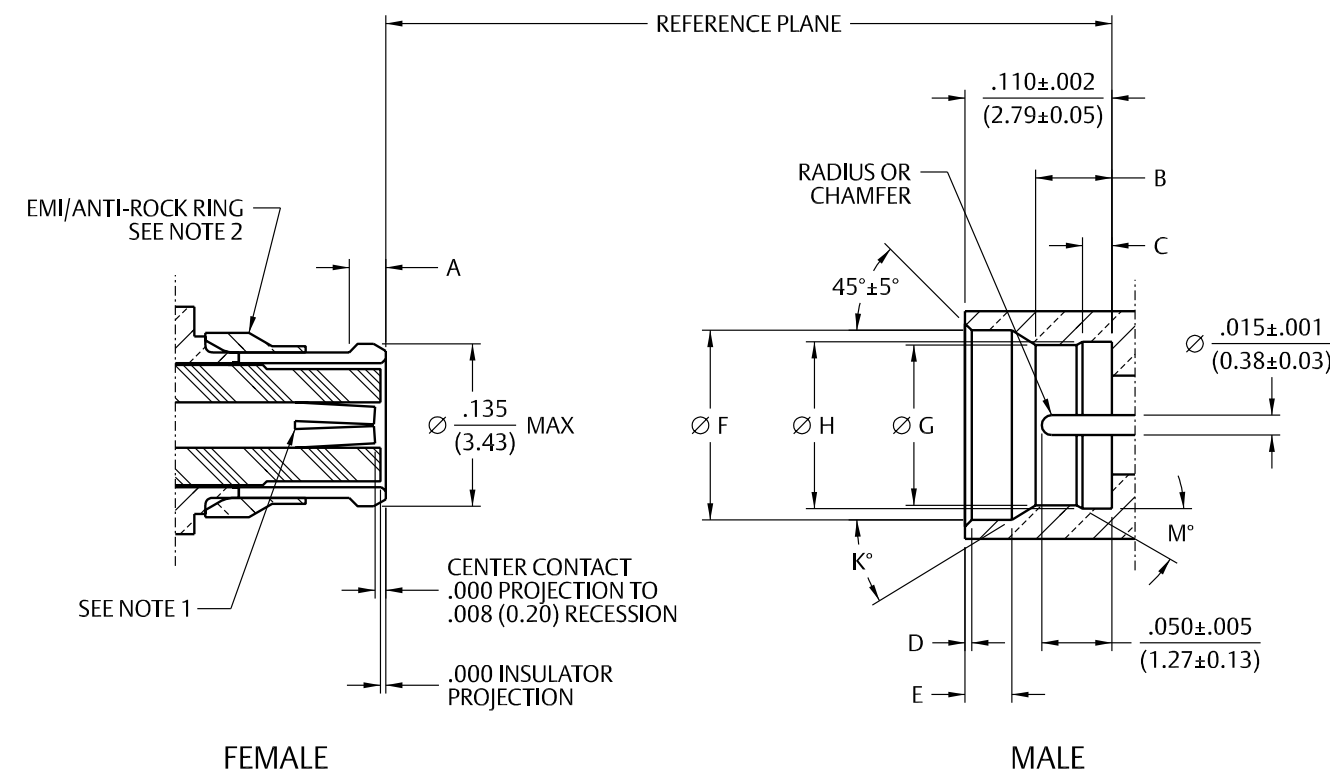

Notes:

1. Socket to accept mating pin  $\varnothing .015 \pm .001$  (0.38±0.03).
2. EMI/Anti-Rock Ring configuration optional, used on cabled connectors only. Shall not prevent proper mating engagement.
3. All dimensions shown in inches. Metric equivalents (rounded to nearest 0.01mm) are given for general information only.

## SMP Female Connector Interface

Dimension	Cabled		Uncabled	
	Min	Max	Min	Max
A	.025 (0.64)	.035 (0.89)	.018 (0.46)	.025 (0.64)

## SMP Male Connector Interface

Dimension	Full Detent		Limited Detent		Smooth Bore		Catcher's Mitt	
	Min	Max	Min	Max	Min	Max	Min	Max
B	.051 (1.30)	.057 (1.45)	.054 (1.37)	.060 (1.52)	.059 (1.50)	.065 (1.65)	N/A	N/A
C	.0205 (0.52)	.0235 (0.60)	.0205 (0.52)	.0235 (0.60)	N/A	N/A	N/A	N/A
D	.003 (0.08)	.008 (0.20)	.003 (0.08)	.008 (0.20)	.003 (0.08)	.008 (0.20)	.043 (1.09)	.047 (1.19)
E	.033 (0.84)	.037 (0.94)	.033 (0.84)	.037 (0.94)	.033 (0.84)	.037 (0.94)	N/A	N/A
F	.139 (3.53)	.145 (3.68)	.139 (3.53)	.145 (3.68)	.139 (3.53)	.145 (3.68)	.123 (3.12)	.127 (3.23)
G	.114 (2.90)	.118 (3.00)	.118 (3.00)	.122 (3.10)	.123 (3.12)	.127 (3.23)	N/A	N/A
H	.124 (3.15)	.126 (3.20)	.124 (3.15)	.126 (3.20)	N/A	N/A	N/A	N/A
K	35° REF	35° REF	35° REF	35° REF	35° REF	35° REF	N/A	N/A
M	30° REF	30° REF	30° REF	30° REF	N/A	N/A	N/A	N/A

For more information, please contact customer service at (507) 833-8822 or (800) 247-8256 • www.EmersonConnectivity.com

Illustrations are shown in inches (millimeters).

## Semi-Rigid Cable and PC Mount

### Female Straight Cabled, Semi-Rigid

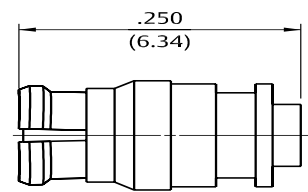

Fig 1

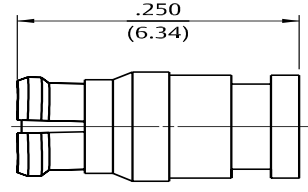
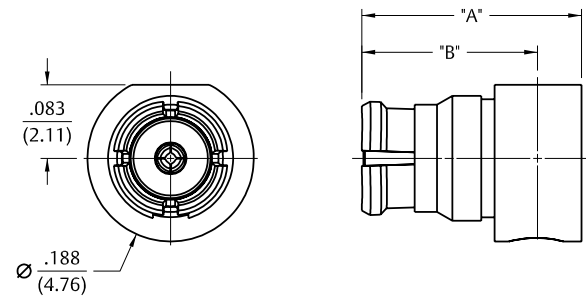

Fig 2

Cable Type	Gold Plated	Figure
M17/151	127-0692-001	1
RG-405	127-0693-001	2

\* Specifications dependant on cable ratings.

### Right Angle Cabled Female



Cable Type	Gold Plated	"A"	"B"
M17/151	127-0692-101	.248 (6.30)	.197 (5.00)
RG-405	127-0693-101	.271 (6.88)	.209 (5.31)

\* Specifications dependant on cable ratings.

### Straight PC Mount Male Receptacle

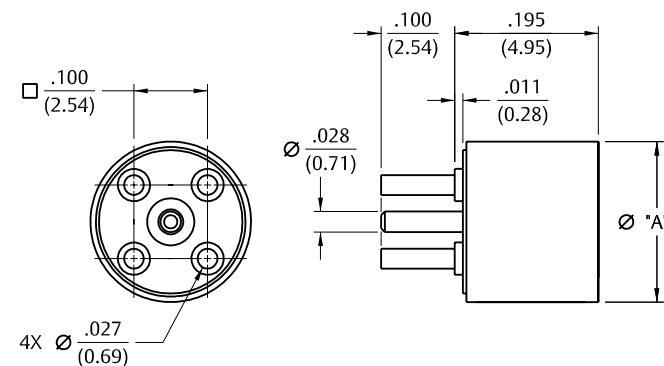

Interface	Passivated	"A"
Full Detent	127-0701-201	.218 (5.54)
Limited Detent	127-1701-201	.218 (5.54)
Smooth Bore	127-2701-201	.218 (5.54)
Catcher's Mitt	127-3701-201	.234 (5.94)

Base and legs gold plated brass.

## PC Mount and Panel Mount

### End Launch Male Receptacle – Surface Mount



Interface	Gold Plated	Packaging
Full Detent	127-0701-801	Stock
Full Detent	127-0701-802	Tape and Reel 1000 pcs/reel
Limited Detent	127-1701-801	Stock
Limited Detent	127-1701-802	Tape and Reel 1000 pcs/reel
Smooth Bore	127-2701-801	Stock
Smooth Bore	127-2701-802	Tape and Reel 1000 pcs/reel

Mounting hole layout figure 1 page 194.

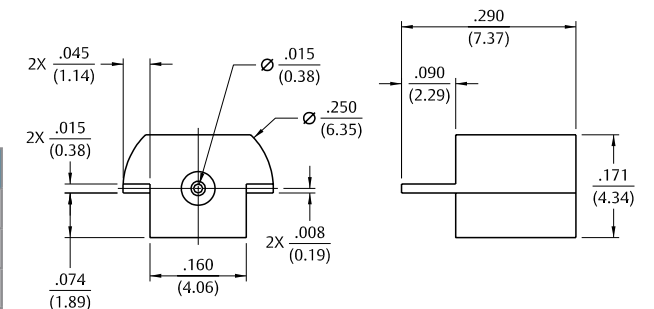

### 2-Hole Flange Mount Male Shroud – Without Contact



Interface	Passivated
Full Detent	127-0701-602
Limited Detent	127-1701-602
Smooth Bore	127-2701-602

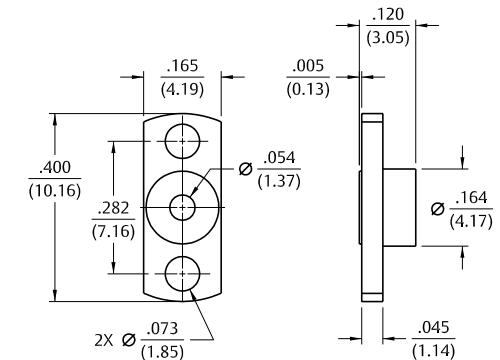

### 2-Hole Flange Mount Male Catcher's Mitt Shroud – Without Contact



Interface	Passivated
Catcher's Mitt	127-3701-602

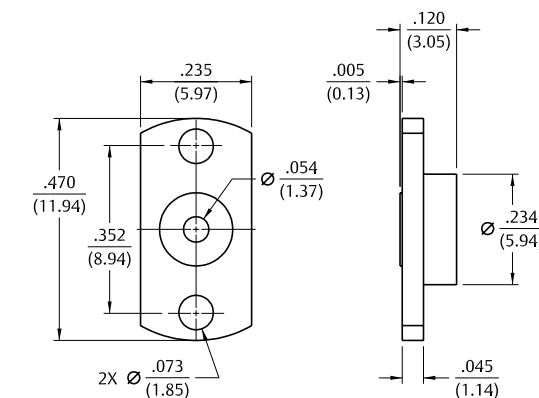



# Panel Mount and Adapters

## 2-Hole Flange Mount Male Field Replaceable

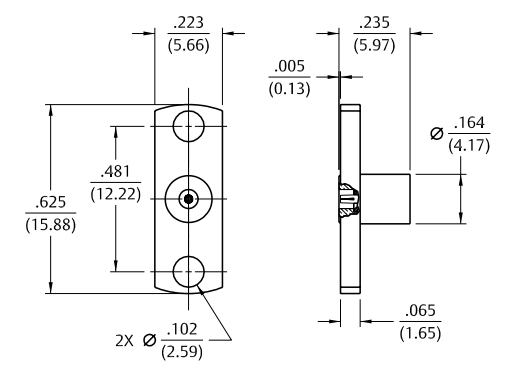

Interface	Passivated	Pin Size
Full Detent	127-0701-612	.012 (.030)
Limited Detent	127-1701-612	.012 (.030)
Smooth Bore	127-2701-612	.012 (.030)

## Hermetic Seal Male

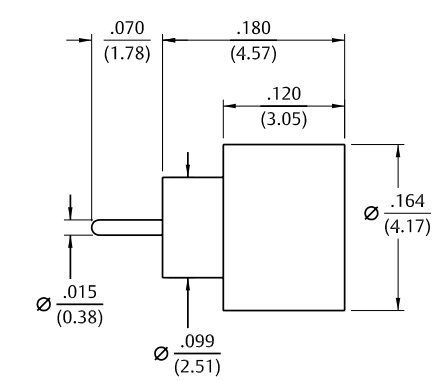

Interface	Gold Plated
Full Detent	127-0711-601
Limited Detent	127-1711-601
Smooth Bore	127-2711-601

## Female to Female Bullet Adapter

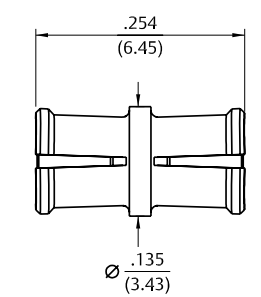

Gold Plated
127-0901-801

## Female to Female Adapter

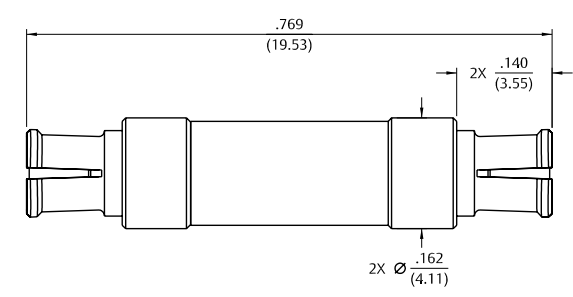

Gold Plated
127-0901-811

## Male to Male Catcher's Mitt Adapter

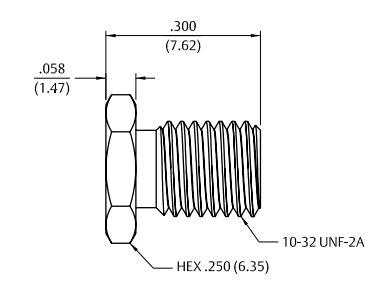

Interface	Passivated
Full Detent	127-0901-821
Limited Detent	127-1901-821
Smooth Bore	127-2901-821

## Type N Connectors

50 Ohm Connectors Specifications..... 146  
 Semi-Rigid & Flexible Cable..... 149  
 Bulkhead & Panel Mount Mount..... 151  
 Adapters..... 151

Other Information  
 Assembly Tools..... 185  
 Capabilities..... 190  
 Cable Information..... 192  
 Assembly Instruction..... 193  
 Mounting Hole Layouts..... 194  
 Numerical Index..... 274  
 Competitor Cross Reference..... 280

3	MMCX Connectors
13	MCX Connectors
39	SMK Connectors
45	SMA Connectors
103	SMB Connectors
131	SMC Connectors
137	SMP Connectors
145	Type N Connectors
153	Shielded Cable Terminations
157	Between-Series Adapters
161	Fixed Length Cable Assemblies
173	Ultra Miniature Connectors (UMC)
181	kwiQMAte™ Connectors
185	Tools
193	Assembly Instructions
257	Electronic Hardware
274	Index

While every precaution has been taken to ensure accuracy and completeness herein, Emerson Network Power Connectivity Solutions assumes no responsibility, and disclaims all liability for damages resulting from use of this information or for any errors or omissions. Specifications subject to change without notice.

For more information, please contact customer service at (507) 833-8822 or (800) 247-8256 • www.EmersonConnectivity.com

## Electrical Specifications

Impedance: 50 Ohms

## Frequency Range:

Flexible Cabled Connectors and Receptacles .....	0-11 GHz
Semi-rigid Cabled Connectors and Receptacles .....	0-18 GHz
<b>VSWR:</b> max (f-GHz).....	0-11 GHz
Straight Flexible Cabled Connectors.....	1.30 max
	<u>0-9 GHz</u> <u>9-11 GHz</u>
Right Angle Flexible Cabled	1.35 max      1.50 max
	<u>0-11 GHz</u> <u>11-18 GHz</u>
RG-405 Semi-Rigid Plugs.....	1.07+.01f      <1.25 Typical
RG-402 Semi-Rigid Plugs.....	1.05+.01f      <1.25 Typical
RG-401 Semi-Rigid Plugs.....	1.06+.01f      <1.25 Typical
RG-405 Semi-Rigid Jacks .....	1.15+.02f      <1.50 Typical
RG-402 Semi-Rigid Jacks .....	1.10+.02f      <1.50 Typical
RG-401 Semi-Rigid Jacks .....	1.10+.02f      <1.50 Typical

Adapters..... 1.05+.01f

Uncabled Receptacles .....

**Working Voltage:** (VRMS max)†

	Sea Level	70K Feet
RG-316, 316 DS .....	250	65
RG-58, 142, 405 .....	335	85
RG-402 .....	500	125
RG-213, 214, 401, LMR-400.....	1000	250
Uncabled Receptacles and Adapters .....	1000	250

**Dielectric Withstanding Voltage:** (VRMS min at sea level)†

RG-316, 316 DS.....	750
RG-58, 142, 405 .....	1000
RG-402 .....	1500
RG-213, 214, 401, LMR-400.....	2500
Uncabled Receptacles and Adapters .....	2500

**Insulation Resistance:** 5000 Megohms min

**Contact Resistance:** (milliohms max)

	Initial	After Environmental
Center Contact		
Straight Cabled Connectors (non-captivated).....	1.0	1.5
Straight Cabled Connectors (captivated) .....	2.5	3.0
Right Angle Cabled Connectors .....	2.5	3.0
Uncabled Receptacles and Adapters.....	1.0	1.5
Outer Contact .....	0.2	N/A
Braid to Body (Flexible Cabled Connectors Only) .....	0.05	N/A

**Corona Level:** (Volts min at 70K feet)†

RG-316, 316 DS.....	190
RG-58, 142, 405 .....	250
RG-402 .....	375
RG-213, 214, 401, LMR-400 and Adapters .....	500
Uncabled Receptacles .....	N/A

**Insertion Loss:** (dB max, tested at 9 GHz)

Straight Flexible Cabled Connectors .....	0.15 max
Right Angle Flexible Cabled Connectors.....	0.30
Semi-rigid Cabled Connectors and Adapters .....	$0.05\sqrt{f(\text{GHz})}$
Uncabled Receptacles .....	N/A

**RF Leakage:** (dB min, tested at 2.5 GHz)

Cabled Connectors and Adapters .....	-90
Uncabled Receptacles .....	N/A

**RF High Potential Withstanding Voltage:** (Vrms min, tested at 4 and 7 MHz)†

RG-316, 316 DS .....	500
RG-58, 142, 405 .....	670
RG-402 .....	1000
RG-213, 214, 401, LMR-400 .....	1500
Uncabled Receptacles and Adapters .....	1500

**IMP3:** Typically <-90 dBm (tested per IEC Guidelines using 20W inputs swept over 1930-1990 MHz)

Type N In-Series Adapter Return Loss

Mechanical Specifications

<b>Engagement Design:</b>	MIL-STD-348A, Series N
<b>Durability:</b>	500 Cycles min
<b>Engagement/Disengagement Force:</b>	6 lb-in max
<b>Mating Torque:</b>	7 to 10 lb-in
<b>Bulkhead Mounting Nut Torque:</b>	15 lb-in recommended
<b>Coupling Proof Torque:</b>	15 lb-in min
<b>Coupling Nut Retention:</b>	100 lbs min
<b>Contact Retention:</b>	(min - captivated contacts only)

	Axial Force (lbs)	Torque (oz-in)
Cabled Connectors and Adapters .....	6	N/A
Uncabled Receptacles .....	6	4

**Cable Retention: (minimum\*)**

	Axial Force (lbs)	Torque (oz-in)
RG-316 .....	20	N/A
RG-316DS.....	30	N/A
RG-58 .....	40	N/A
RG-142 .....	45	N/A
RG-213, 214 and LMR-400 .....	90	N/A
RG-405 .....	30	16
RG-402 .....	60	55
RG-401 .....	90	80

\* or cable breaking strength, whichever is less.

For more information, please contact customer service at (507) 833-8822 or (800) 247-8256 • www.EmersonConnectivity.com

Illustrations are shown in inches (millimeters).

Johnson  
Connectivity Solutions

TYPE N CONNECTORS – 50 OHM

† Avoid user injury due to misapplication. See safety advisory definitions inside front cover.

146

# Specifications

## Environmental Specifications

(Meets or Exceeds the Applicable Paragraph of MIL-PRF-39012)

- Temperature Range:** -65°C to +165°C
- Thermal Shock:** MIL-STD-202, Method 107, Condition B (except +85°C high temperature)
- Corrosion:** MIL-STD-202, Method 101, Condition B
- Shock:** MIL-STD-202, Method 213, Condition I
- Vibration:** MIL-STD-202, Method 204, Condition B
- Moisture Resistance:** MIL-STD-202, Method 106

## Material Specifications

- Bodies:** Crimp – Brass per ASTM B16, Tri-Alloy (Cu/Sn/Zn) plated (.0001" min)  
Solder – Brass per ASTM B16, Gold plated\* per SAE-AMS2423 (.00001" min)  
Adapter – Brass per ASTM B16, Tri-Alloy (Cu/Sn/Zn) or Nickel per QQ-N-290 plated (.0001" min)
- Contacts:** Male – Brass per ASTM B16, Gold plated\* per MIL-G-45204 (.00005" min)  
Female – Beryllium Copper per ASTM B196, Gold plated\* per MIL-DTL-45204 (.00005" min)  
Adapter – Beryllium Copper per ASTM B196, Gold plated\* per MIL-DTL-45204 (.00005" min)
- Insulators:** PTFE Fluorocarbon per ASTM D1710 and ASTM D1457
- Gaskets:** Silicon Rubber per A-A-59588A
- Crimp Sleeves:** Copper per ASTM B301, Tri-Alloy (Cu/Sn/Zn) plated (.0001" min)
- End Caps:** Brass per ASTM B16, Tri-Alloy (Cu/Sn/Zn) plated (.0001" min)
- Nut Retention Spring (Plugs):** Beryllium Copper per ASTM B196, un-plated
- Mounting Nut (Bulkhead Jacks):** Brass per ASTM B16, Nickel plated per SAE-AMS2423 (.0001" min)
- Lock Washer (Bulkhead Jacks):** Steel, Zinc plated (.0001" min)

\* All Gold plated parts include a .00005" minimum Nickel under plated barrier layer

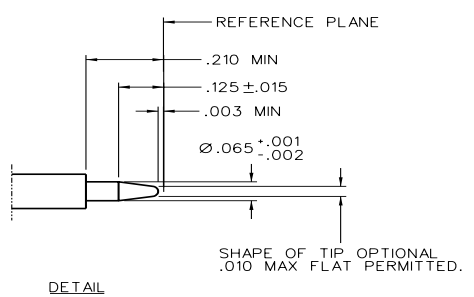
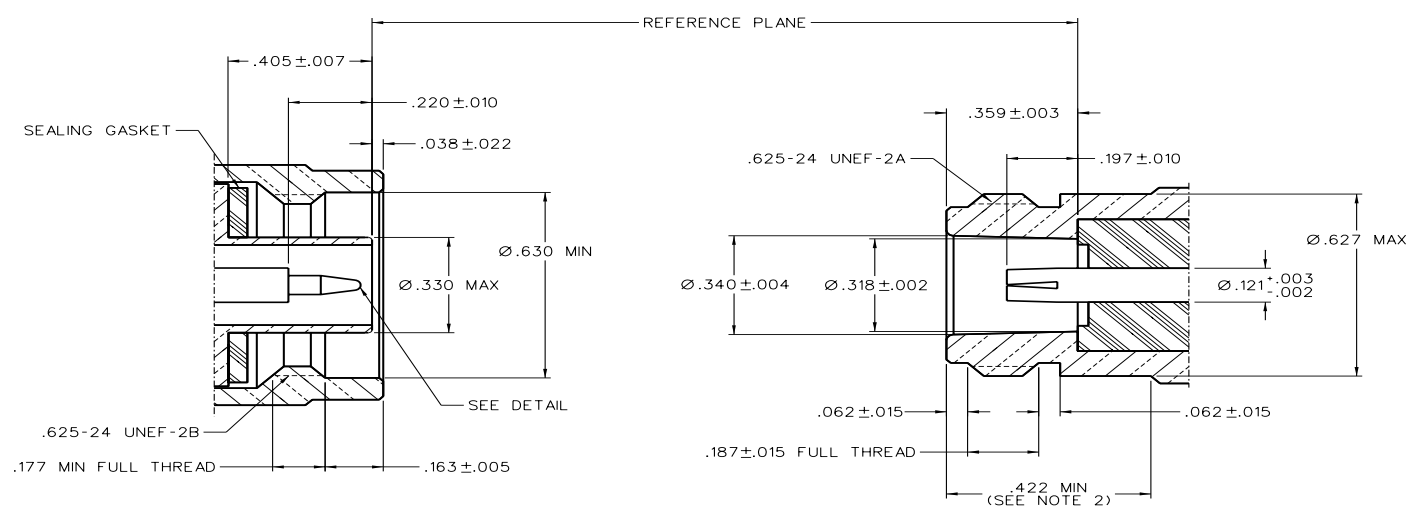

NOTES:  
1. THIS INTERFACE SHALL MEET THE GAUGE REQUIREMENTS AS SPECIFIED IN MIL-PRF-39012/1G AND /2G.  
2. CLEARANCE FOR MATING CONNECTOR COUPLING NUT.

## Straight Solder Type Plug – With Solder Contact

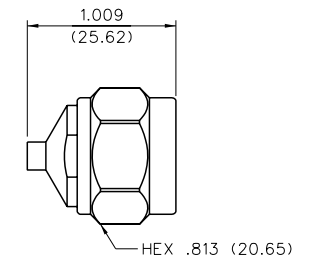

Cable Type	Gold Plated
RG-405	138-4693-001*
RG-402	138-4694-001*
RG-401	138-4696-001*

Assembly instructions page 246.  
\* Tri-Alloy plated coupling nut

## Straight Solder Type Plug – Captivated Solderless Contact

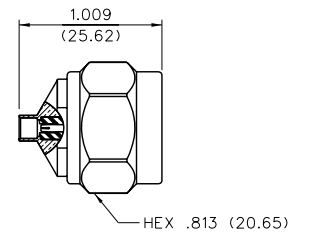

Cable Type	Gold Plated
RG-405	138-4693-011*
RG-402	138-4694-011*
RG-401	138-4696-011*

Assembly instructions page 247.  
\* Tri-Alloy plated coupling nut

## Straight Solder Type Bulkhead Jack – With Solder Contact

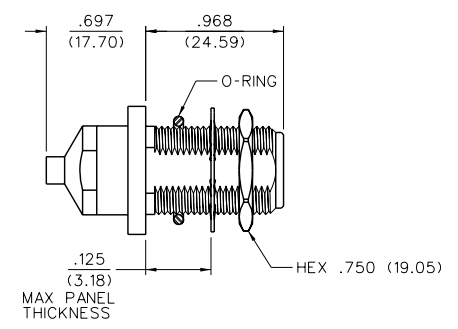

Cable Type	Gold Plated
RG-405	138-4593-401*
RG-402	138-4594-401*
RG-401	138-4596-401*

Assembly instructions page 250.  
\* Tri-Alloy plated bulkhead jack body  
Mounting hole layout figure 5 page 194.

# Flexible Cable

## Straight Crimp Type Plug – Solder or Crimp Contact



Cable Type	Tri-Alloy Plated	Figure
RG-161, 174, 188, 316	138-4403-007	1
RG-188 DS, RG-316 DS	138-4404-007	1
RG-58, 141, 303	138-4407-007	2
RG-55, 142, 223, 400	138-4408-007	2
RG-8, 213	138-4416-007	3
RG-9, 214	138-4418-007	3
LMR-400, BELDEN 9913	138-4449-007	3

Assembly instructions page 242 and 243.  
 \* Tri-Alloy plated coupling nut

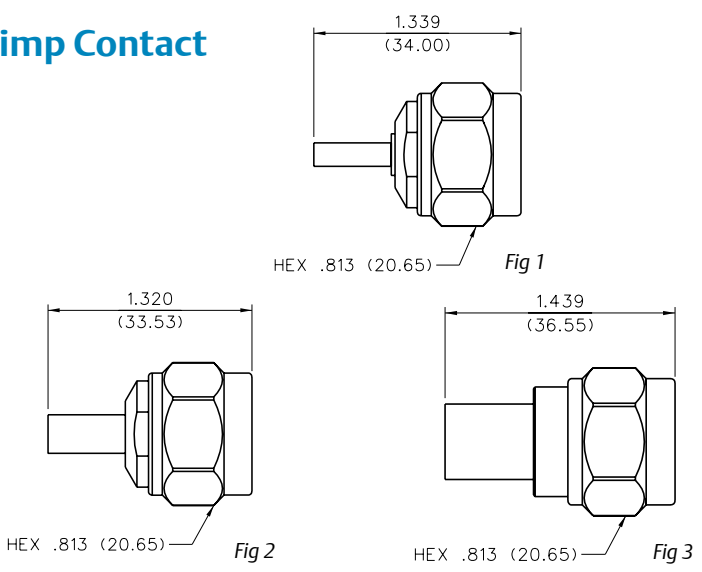

## Right Angle Crimp Type Plug – Captivated Contact



Cable Type	Tri-Alloy Plated	Figure	"A"	"B"
RG-161, 174, 188, 316	138-4403-107	1	1.227 (31.17)	0.977 (24.82)
RG-188 DS, RG-316 DS	138-4404-107	1	1.227 (31.17)	0.977 (24.82)
RG-58, 141, 303	138-4407-107	2	1.253 (31.83)	1.003 (25.48)
RG-55, 142, 223, 400	138-4408-107	2	1.253 (31.83)	1.003 (25.48)
RG-8, 213	138-4416-107	2	1.365 (34.67)	1.115 (28.32)
RG-9, 214	138-4418-107	2	1.365 (34.67)	1.115 (28.32)

Assembly instructions page 244 and 245.  
 \* Tri-Alloy plated coupling nut

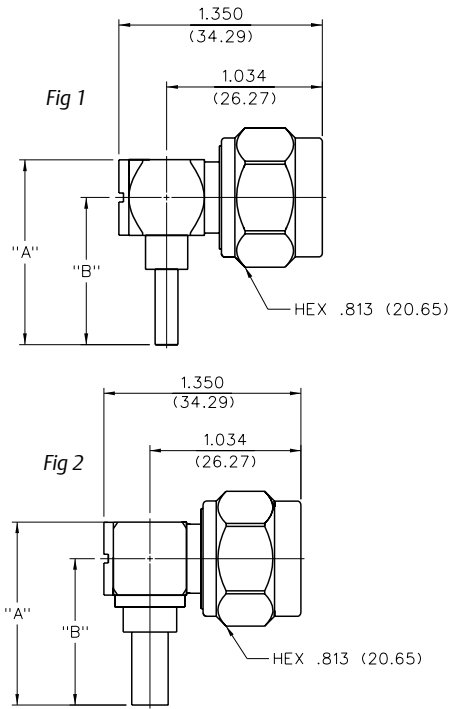

## Straight Crimp Type Bulkhead Jack – Solder or Crimp Contact



Cable Type	Tri-Alloy Plated	"A"
RG-161, 174, 188, 316	138-4303-407	.943 (23.95)
RG-188 DS, RG-316 DS	138-4304-407	.943 (23.95)
RG-58, 141, 303	138-4307-407	.943 (23.95)
RG-55, 142, 223, 400	138-4308-407	.943 (23.95)
RG-8, 213	138-4316-407	.997 (25.32)
RG-9, 214	138-4318-407	.997 (25.32)
LMR-400, BELDEN 9913	138-4349-407	.997 (25.32)

Assembly instructions page 248 and 251.  
 Mounting hole layout figure 9 page 194.

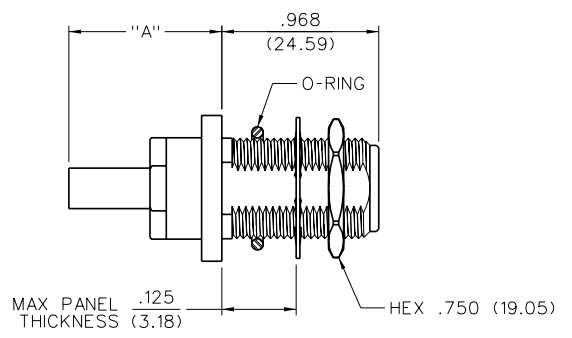

# Bulkhead, Panel Mount and In-Series Adapters

## Rear Mount Bulkhead Jack Receptacle



Tri-Alloy Plated  
 138-4701-407

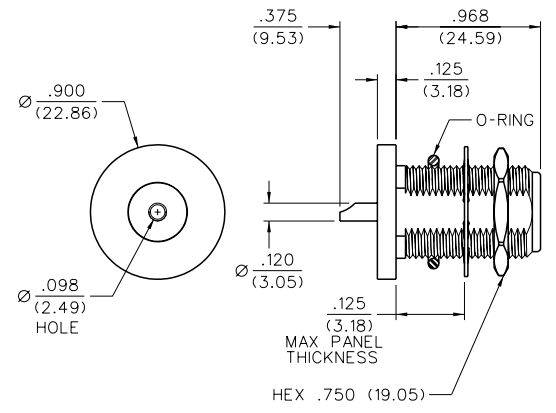

## 4-Hole Flange Mount Jack Receptacle – Flush Dielectric



Tri-Alloy Plated  
 138-4701-607

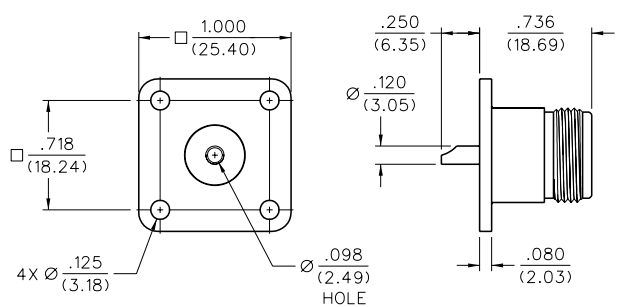

## Jack to Jack Adapter



Tri-Alloy Plated  
 138-4901-807

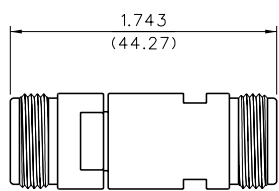

For more information, please contact customer service at (507) 833-8822 or (800) 247-8256 • www.EmersonConnectivity.com  
 Illustrations are shown in inches (millimeters).

## In-Series Adapters

### Jack to Bulkhead Jack Adapter



Tri-Alloy Plated  
138-4901-407

Mounting hole layout figure 1 page 194.

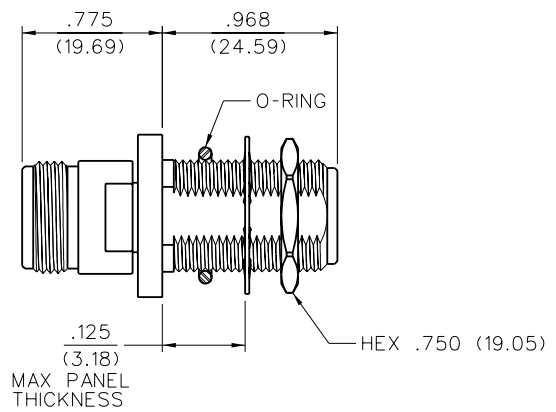

### Plug to Plug Adapter



Tri-Alloy Plated  
138-4901-817

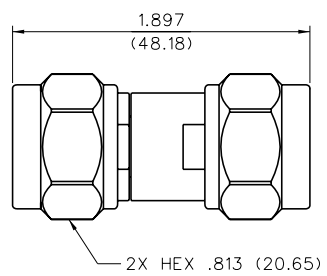

### Shielded Cable Terminations

50 Ohm Connectors  
 Specifications..... 154  
 Semi-Rigid & Flexible Cable..... 155  
 PC Mount ..... 156

Other Information  
 Assembly Tools ..... 185  
 Capabilities ..... 190  
 Cable Information ..... 192  
 Assembly Instruction ..... 193  
 Mounting Hole Layouts..... 194  
 Numerical Index..... 274  
 Competitor Cross Reference ..... 280

3	MMCX Connectors
13	MCX Connectors
39	SMK Connectors
45	SMA Connectors
103	SMB Connectors
131	SMC Connectors
137	SMP Connectors
145	Type N Connectors
153	Shielded Cable Terminations
157	Between-Series Adapters
161	Fixed Length Cable Assemblies
173	Ultra Miniature Connectors (UMC)
181	kwiQMate™ Connectors
185	Tools
193	Assembly Instructions
257	Electronic Hardware
274	Index

While every precaution has been taken to ensure accuracy and completeness herein, Emerson Network Power Connectivity Solutions assumes no responsibility, and disclaims all liability for damages resulting from use of this information or for any errors or omissions. Specifications subject to change without notice.

# Specifications

## Electrical Specifications

<b>Engagement Design:</b>	Impedance: 29 ohms
<b>Frequency Range:</b>	0 - 2 GHz
<b>Working Voltage:</b>	300 VRMS†
<b>Dielectric Withstanding Voltage:</b>	2000 VDC†
<b>Contact Resistance:</b>	Center Contact: 6 milliohms Outer conductor: 2.5 milliohms

## Mechanical Specifications

<b>Insertion Force:</b>	Inner conductor: 32 oz. max. 2 oz. min. Outer conductor: 48 oz. max. 6 oz. min.
<b>Durability:</b>	250 cycles

## Environmental Ratings

<b>Temperature Range:</b>	-65° C to + 85° C
<b>Corrosion:</b>	Salt spray, 24 hours
<b>Shock:</b>	Method 213, Test Condition B, MIL-STD-202
<b>Vibration:</b>	Method 204, Test Condition B, MIL-STD-202

## Material Specifications

<b>Contact:</b>	Beryllium copper per QQ-C-533/530
<b>Insulator Material:</b>	TFE Fluorocarbon per L-P-403
<b>Finish:</b>	Center Contact and Body: Gold

SHIELDED TEST JACK INTERFACE -  
TYPICAL PROBE TYPE

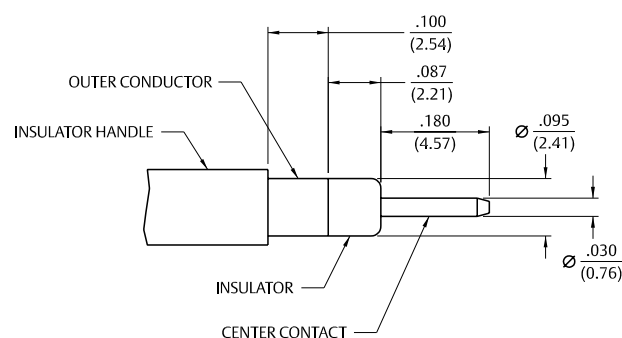
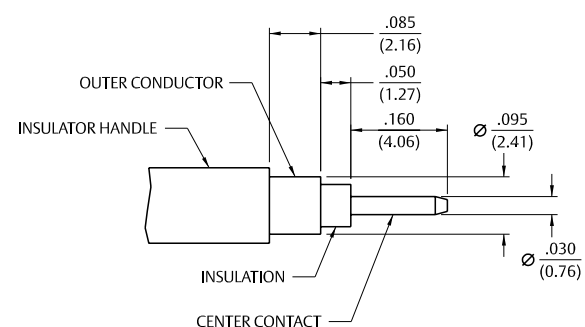

## Flexible Cable – Straight Crimp Type



Cable Type	Gold Plated	Nickel Plated
RG-161/U, 174, 179, 187, 188, 316	142-0003-201	142-0003-206
RG-316 DS, RG-188 DS	142-0004-201	142-0004-206

Assembly instructions page 252. Mounting hole layout figure 3 page 194.

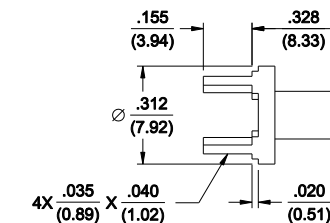

## Flexible Cable – Straight Crimp Type



Cable Type	Gold Plated	Nickel Plated	"A"
RG-178/U, 196	142-0002-221	142-0002-226	.110 (2.79)
RG-316/U, 188, 174, 161, 179, 187	142-0003-231	142-0003-236	.155 (3.94)
	142-0003-241	142-0003-246	.110 (2.79)
RG-316 DS, 188 DS	142-0004-211	142-0004-216	.155 (3.94)
	142-0004-221	142-0004-226	.110 (2.79)

Assembly instructions page 252. Mounting hole layout figure 14 page 195.

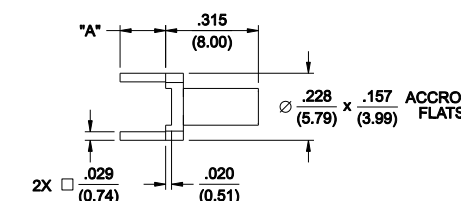

## Flexible Cable – Right Angle Crimp Type



Cable Type	Gold Plated	Nickel Plated
RG-161/U, 174, 179, 187, 188, 316	142-0003-301	142-0003-306
RG-316 DS, RG-188 DS	142-0004-301	142-0004-306

Assembly instructions page 252. Mounting hole layout figure 3 page 194.

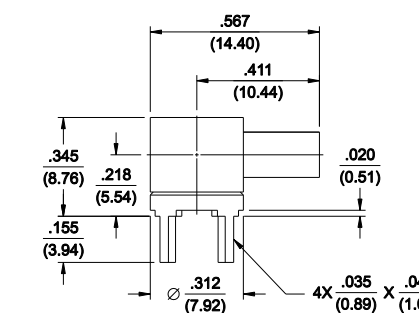

## Semi-Rigid – Straight Solder Type End Launch



Cable Type	Gold Plated	Board Thickness	"A"	"B"	"C"	"D"	"H"	"W"
.086 Semi-Rigid	142-0093-801	0.062 (1.57)	0.068 (1.73)	0.046 (1.42)	0.150 (3.81)	0.032 (0.81)	0.250 (6.35)	0.250 (6.35)
.141 Semi-Rigid	142-0094-801	0.062 (1.57)	0.068 (1.73)	0.070 (1.78)	0.187 (4.77)	0.040 (1.02)	0.312 (7.92)	0.375 (9.52)
.250 Semi-Rigid	142-0096-801	0.062 (1.57)	0.068 (1.73)	0.053 (1.35)	0.187 (4.77)	0.050 (1.27)	0.312 (7.92)	0.375 (9.52)

Assembly instructions page 253.

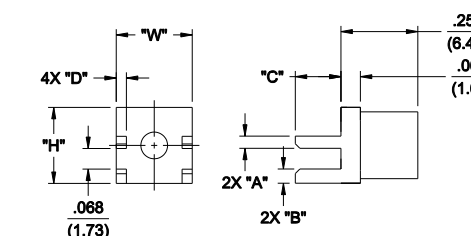

# Flexible Cable & PC Mount

## Flexible Cable – Straight Crimp Type End Launch

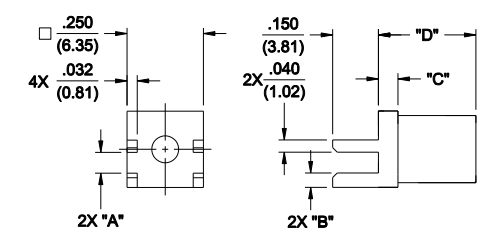

Cable Type	Gold Plated	Board Thickness	"A"	"B"	"C"	"D"
RG-316/U, 188, 174, 161, 179, 187	142-0003-801	0.062 (1.57)	0.068 (1.73)	0.046 (1.02)	0.055 (1.40)	0.310 (7.87)
RG-316 DS, 188 DS, 179 DS, 187 DS	142-0004-801	0.062 (1.57)	0.068 (1.73)	0.046 (1.02)	0.065 (1.65)	0.320 (8.13)
RG-58/U, 141, 303	142-0007-801	0.062 (1.57)	0.068 (1.73)	0.037 (1.65)	0.065 (1.65)	0.320 (8.13)
RG-142/U, 55, 223, 400	142-0008-801	0.062 (1.57)	0.068 (1.73)	0.037 (1.65)	0.065 (1.65)	0.320 (8.13)
RG-178/U, 196	142-0002-811	0.047 (1.19)	0.053 (1.35)	0.065 (1.65)	0.065 (1.65)	0.320 (8.13)
RG-316/U, 188, 174, 161, 179, 187	142-0003-811	0.047 (1.19)	0.053 (1.35)	0.061 (1.55)	0.065 (1.65)	0.320 (8.13)
RG-316 DS, 188 DS, 179 DS, 187 DS	142-0004-811	0.047 (1.19)	0.053 (1.35)	0.061 (1.55)	0.065 (1.65)	0.320 (8.13)
RG-58/U, 141, 303	142-0007-811	0.047 (1.19)	0.053 (1.35)	0.052 (1.32)	0.065 (1.65)	0.320 (8.13)
RG-142/U, 55, 223, 400	142-0008-811	0.047 (1.19)	0.053 (1.35)	0.052 (1.32)	0.065 (1.65)	0.320 (8.13)

Assembly instructions page 253.

## Flexible Cable – Straight Crimp Type Surface Mount End Launch



Cable Type	Gold Plated
RG-178/U, 196	142-0002-821

Recommended land pattern figure 12 page 194.  
Assembly instructions page 254.

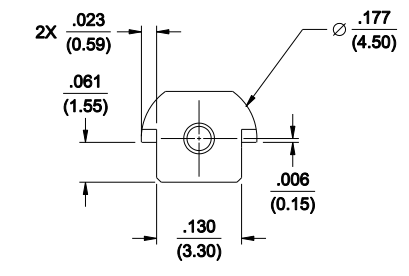

## Horizontal



Gold Plated
129-0701-302

Mounting hole layout figure 15 page 195.

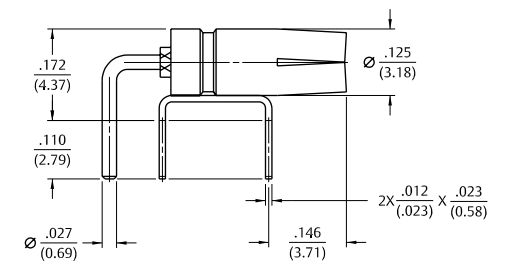

## Vertical



Gold Plated
129-0701-202

Mounting hole layout figure 16 page 195.

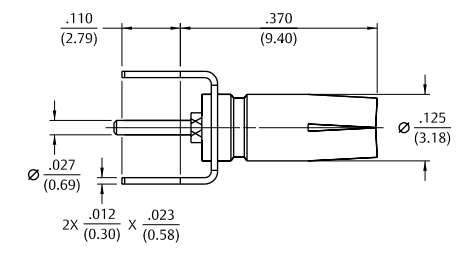

### Between-Series Adapters

- SMA to SMB..... 160
- SMA to MCX..... 160
- SMA to MMCX..... 160
- Other Information
- Assembly Tools ..... 185
- Capabilities ..... 190
- Cable Information ..... 192
- Assembly Instruction ..... 193
- Mounting Hole Layouts..... 194
- Numerical Index..... 274
- Competitor Cross Reference ..... 280

While every precaution has been taken to ensure accuracy and completeness herein, Emerson Network Power Connectivity Solutions assumes no responsibility, and disclaims all liability for damages resulting from use of this information or for any errors or omissions. Specifications subject to change without notice.

- 3 **MMCX Connectors**
- 13 **MCX Connectors**
- 39 **SMK Connectors**
- 45 **SMA Connectors**
- 103 **SMB Connectors**
- 131 **SMC Connectors**
- 137 **SMP Connectors**
- 145 **Type N Connectors**
- 153 **Shielded Cable Terminations**
- 157 **Between-Series Adapters**
- 161 **Fixed Length Cable Assemblies**
- 173 **Ultra Miniature Connectors (UMC)**
- 181 **kwiQMate™ Connectors**
- 185 **Tools**
- 193 **Assembly Instructions**
- 257 **Electronic Hardware**
- 274 **Index**

## SMA to SMB

### SMA Plug to SMB Jack Adapter



Gold Plated  
134-1012-011

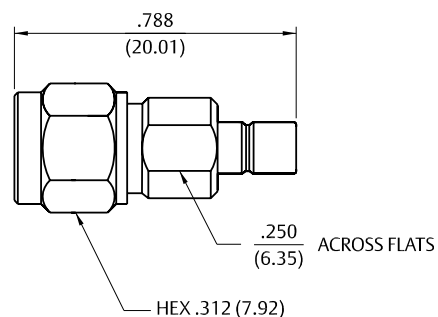

### SMA Plug to SMB Plug Adapter



Gold Plated  
134-1012-021

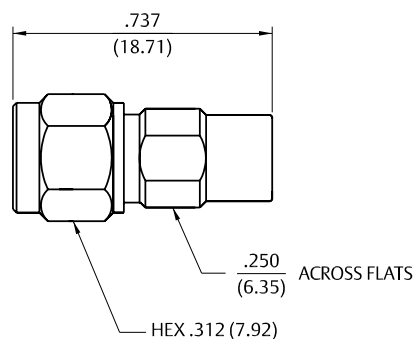

### SMA Jack to SMB Plug Adapter



Gold Plated  
134-1012-041

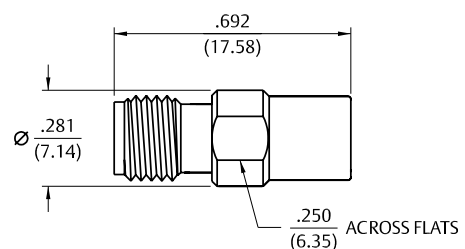

### SMA Plug to MCX Jack Adapter



Gold Plated  
134-1018-001

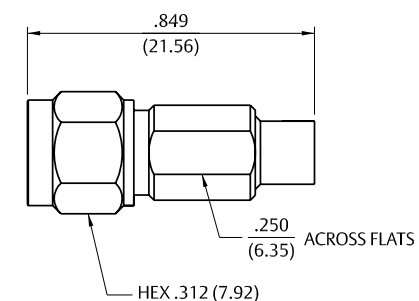

### SMA Plug to MCX Plug Adapter



Gold Plated  
134-1018-011

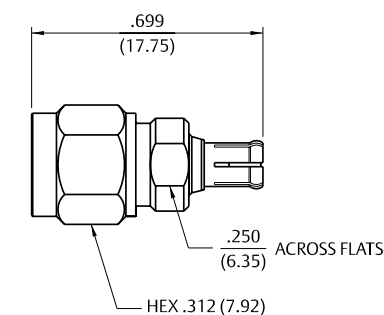

### SMA Jack to MCX Jack Adapter



Gold Plated  
134-1018-021

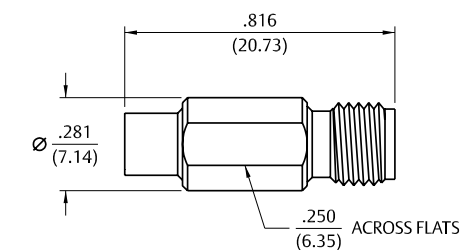

### SMA Jack to MCX Plug Adapter



Gold Plated  
134-1018-031

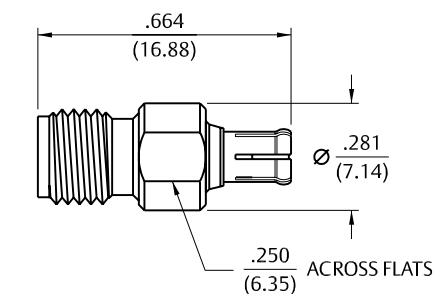

## SMA to MCX



## SMA to MMCX

### SMA Plug to MMCX Jack Adapter



Gold Plated  
134-1019-151

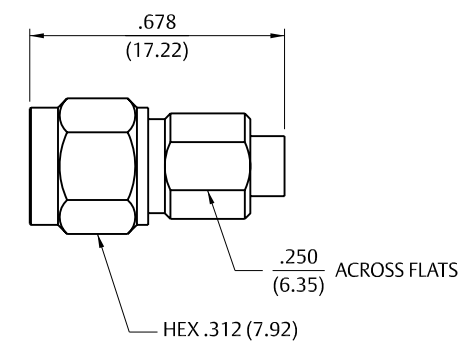

### SMA Plug to MMCX Plug Adapter



Gold Plated  
134-1019-161

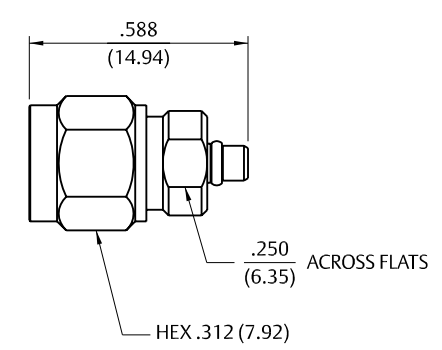

### SMA Jack to MMCX Jack Adapter



Gold Plated  
134-1019-171

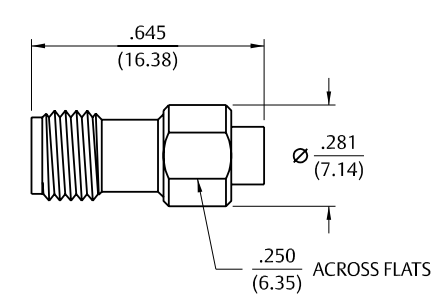

### SMA Jack to MMCX Plug Adapter



Gold Plated  
134-1019-181

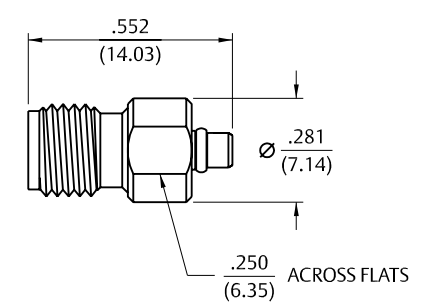

### Fixed Length Cable Assemblies

Specification .....	162
MMCX to MMCX .....	163
MMCX to SMA .....	163
MCX to MCX .....	164
SMA to SMA .....	165
SMB to SMB .....	168
Type N to Type N .....	170
BNC to BNC .....	170
75 Ohm to 75 Ohm BNC .....	171
SMA to BNC .....	171
SMA to Type N .....	171
QMA to QMA .....	172
BNC to BNC .....	170
Other Information	
Assembly Tools .....	185
Capabilities .....	190
Cable Information .....	192
Assembly Instruction .....	193
Mounting Hole Layouts .....	194
Numerical Index .....	274
Competitor Cross Reference .....	280

While every precaution has been taken to ensure accuracy and completeness herein, Emerson Network Power Connectivity Solutions assumes no responsibility, and disclaims all liability for damages resulting from use of this information or for any errors or omissions. Specifications subject to change without notice.

<b>3</b>	<b>MMCX Connectors</b>
<b>13</b>	<b>MCX Connectors</b>
<b>39</b>	<b>SMK Connectors</b>
<b>45</b>	<b>SMA Connectors</b>
<b>103</b>	<b>SMB Connectors</b>
<b>131</b>	<b>SMC Connectors</b>
<b>137</b>	<b>SMP Connectors</b>
<b>145</b>	<b>Type N Connectors</b>
<b>153</b>	<b>Shielded Cable Terminations</b>
<b>157</b>	<b>Between-Series Adapters</b>
<b>161</b>	<b>Fixed Length Cable Assemblies</b>
<b>173</b>	<b>Ultra Miniature Connectors (UMC)</b>
<b>181</b>	<b>kwiQMAte™ Connectors</b>
<b>185</b>	<b>Tools</b>
<b>193</b>	<b>Assembly Instructions</b>
<b>257</b>	<b>Electronic Hardware</b>
<b>274</b>	<b>Index</b>

# Specifications

## Electrical Ratings

Electrical ratings of a cable assembly are determined by the limiting connector type and cable size.

Connector	Cable	Connector Impedance (Ohms)	Frequency (GHz)	Dielectric With-standing Voltage (VRMS)	Working Voltage (VRMS)
MMCX	RG-178	50	6	500 Vms	170 Vms
	RG-316	50	6	500 Vms	170 Vms
MCX	RG-178	50	6	750 Vms	250 Vms
	RG-316	50	6	1000 Vms	335 Vms
	RG-316DS	50	6	1000 Vms	335 Vms
MCX 75 Ohm	RG-179	75	6	1000 Vms	335 Vms
	BELDEN 735A	75	6	1000 Vms	335 Vms
SMA	RG-178	50	12.4	500 Vms	170 Vms
	RG-316	50	12.4	750 Vms	250 Vms
	RG-316DS	50	12.4	750 Vms	250 Vms
	RG-58	50	12.4	1000 Vms	335 Vms
	RG-142	50	12.4	1000 Vms	335 Vms
	Hand-Formable .086	50	26.5	1000 Vms	335 Vms
	Hand-Formable .141	50	26.5	1500 Vms	500 Vms
SMB	RG-178	50	4	750 Vms	250 Vms
	RG-316	50	4	1000 Vms	335 Vms
SMB Mini 75 Ohm	RG-179	75	2	1000 Vms	335 Vms
	RG-179DS	75	2	1000 Vms	335 Vms
	BELDEN 735A	75	2	1000 Vms	335 Vms
BNC	RG-58	50	4	1500 Vms	500 Vms
	BELDEN 8218	50	4	1500 Vms	500 Vms
	RG-59	50	4	1500 Vms	500 Vms
	RG-59 PLENUM	50	4	1500 Vms	500 Vms
BNC 75 Ohm	BELDEN 8218	75	3	1500 Vms	500 Vms
	RG-59	75	3	1500 Vms	500 Vms
	BELDEN 8281	75	3	1500 Vms	500 Vms
	COMM SCOPE 735	75	3	1500 Vms	500 Vms
	BELDEN 735A	75	3	1500 Vms	500 Vms
	BELDEN 734A	75	3	1500 Vms	500 Vms
	BELDEN 1694A	75	3	1500 Vms	500 Vms
N	RG-58	50	11	1500 Vms	500 Vms
	RG -142	50	11	1500 Vms	500 Vms
	RG-8	50	11	1500 Vms	500 Vms
	RG-213	50	11	1500 Vms	500 Vms

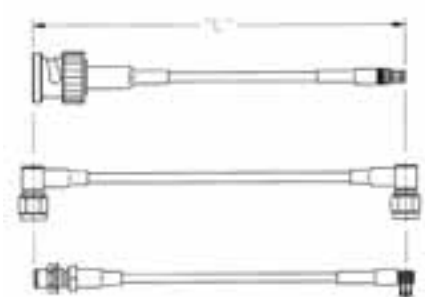

Emerson Connectivity Solutions cable length applies to the end of straight connectors. The length is applied to the vertical centroid of right angle connectors.

## MMCX Straight Plug to MMCX Straight Plug



Part No.	Cable Type	Cable Length	Connector A	Connector B
415-0066-006	RG-176	6"	135-3402-001	135-3402-001
415-0066-012	RG-178	12"	135-3402-001	135-3402-001
415-0066-018	RG-178	18"	135-3402-001	135-3402-001
415-0066-024	RG-178	24"	135-3402-001	135-3402-001

Part No.	Cable Type	Cable Length	Connector A	Connector B
415-0067-006	RG-316	6"	135-3403-001	135-3403-001
415-0067-012	RG-316	12"	135-3403-001	135-3403-001
415-0067-018	RG-316	18"	135-3403-001	135-3403-001
415-0067-024	RG-316	24"	135-3403-001	135-3403-001

## MMCX Right Angle Plug to MMCX Right Angle Plug



Part No.	Cable Type	Cable Length	Connector A	Connector B
415-0068-006	RG-178	6"	135-3402-101	135-3402-101
415-0068-012	RG-178	12"	135-3402-101	135-3402-101
415-0068-018	RG-178	18"	135-3402-101	135-3402-101
415-0068-024	RG-178	24"	135-3402-101	135-3402-101

Part No.	Cable Type	Cable Length	Connector A	Connector B
415-0069-006	RG-316	6"	135-34	135-3403-101
415-0069-012	RG-316	12"	135-3403-101	135-3403-101
415-0069-018	RG-316	18"	135-3403-101	135-3403-101
415-0069-024	RG-316	24"	135-3403-101	135-3403-101

## MMCX Straight Plug to SMA Straight Bulkhead Jack



Part No.	Cable Type	Cable Length	Connector A	Connector B
415-0070-006	RG-178	6"	135-3402-001	142-0302-431
415-0070-012	RG-178	12"	135-3402-001	142-0302-431
415-0070-018	RG-178	18"	135-3402-001	142-0302-431
415-0070-024	RG-178	24"	135-3402-001	142-0302-431
415-0070-036	RG-178	36"	135-3402-001	142-0302-431

Part No.	Cable Type	Cable Length	Connector A	Connector B
415-0071-006	RG-316	6"	135-3403-001	142-0303-411
415-0071-012	RG-316	12"	135-3403-001	142-0303-411
415-0071-018	RG-316	18"	135-3403-001	142-0303-411
415-0071-024	RG-316	24"	135-3403-001	142-0303-411
415-0071-036	RG-316	36"	135-3403-001	142-0303-411

## MMCX Right Angle Plug to SMA Straight Bulkhead Jack



Part No.	Cable Type	Cable Length	Connector A	Connector B
415-0072-006	RG-178	6"	135-3402-101	142-0302-431
415-0072-012	RG-178	12"	135-3402-101	142-0302-431
415-0072-018	RG-178	18"	135-3402-101	142-0302-431
415-0072-024	RG-178	24"	135-3402-101	142-0302-431
415-0072-036	RG-178	36"	135-3402-101	142-0302-431

Part No.	Cable Type	Cable Length	Connector A	Connector B
415-0073-006	RG-316	6"	135-3403-101	142-0303-411
415-0073-012	RG-316	12"	135-3403-101	142-0303-411
415-0073-018	RG-316	18"	135-3403-101	142-0303-411
415-0073-024	RG-316	24"	135-3403-101	142-0303-411
415-0073-036	RG-316	36"	135-3403-101	142-0303-411

For more information, please contact customer service at (507) 833-8822 or (800) 247-8256 • [www.EmersonConnectivity.com](http://www.EmersonConnectivity.com)  
Illustrations are shown in inches (millimeters).

### MCX Straight Plug to MCX Straight Plug



Part No.	Cable Type	Cable Length	Connector A	Connector B
415-0014-006	RG -178	6"	133-3402-021	133-3402-021
415-0014-012	RG -176	12"	133-3402-021	133-3402-021
415-0014-018	RG -178	18"	133-3402-021	133-3402-021
415-0014-024	RG -178	24"	133-3402-021	133-3402-021
415-0014-030	RG -178	30"	133-3402-021	133-3402-021
415-0014-036	RG -178	36"	133-3402-021	133-3402-021
415-0018-006	RG -316	6"	133-3403-001	133-3403-001
415-0018-012	RG -316	12"	133-3403-001	133-3403-001
415-0018-018	RG -316	18"	133-3403-001	133-3403-001

Part No.	Cable Type	Cable Length	Connector A	Connector B
415-0018-024	RG -316	24"	133-3403-001	133-3403-001
415-0018-030	RG -316	30"	133-3403-001	133-3403-001
415-0018-036	RG -316	36"	133-3403-001	133-3403-001
415-0020-006	RG -316	6"	133-3404-001	133-3404-001
415-0020-012	RG-316DS	12"	133-3404-001	133-3404-001
415-0020-018	RG-316DS	18"	133-3404-001	133-3404-001
415-0020-024	RG-316DS	24"	133-3404-001	133-3404-001
415-0020-030	RG-316DS	30"	133-3404-001	133-3404-001
415-0020-036	RG-316DS	36"	133-3404-001	133-3404-001

### MCX Straight Plug to MCX Straight Bulkhead Jack



Part No.	Cable Type	Cable Length	Connector A	Connector B
415-0016-006	RG -316	6"	133-3403-001	133-3303-401
415-0016-012	RG -316	12"	133-3403-001	133-3303-401
415-0016-018	RG -316	18"	133-3403-001	133-3303-401

Part No.	Cable Type	Cable Length	Connector A	Connector B
415-0016-024	RG -316	24"	133-3403-001	133-3303-401
415-0016-030	RG -316	30"	133-3403-001	133-3303-401
415-0016-036	RG -316	36"	133-3403-001	133-3303-401

### MCX Straight Plug to MCX Right Angle Plug



Part No.	Cable Type	Cable Length	Connector A	Connector B
415-0017-006	RG -316	6"	133-3403-001	133-3403-101
415-0017-012	RG -316	12"	133-3403-001	133-3403-101
415-0017-018	RG -316	18"	133-3403-001	133-3403-101

Part No.	Cable Type	Cable Length	Connector A	Connector B
415-0017-024	RG -316	24"	133-3403-001	133-3403-101
415-0017-030	RG -316	30"	133-3403-001	133-3403-101
415-0017-036	RG -316	36"	133-3403-001	133-3403-101

### MCX Right Angle Plug to MCX Right Angle Plug



Part No.	Cable Type	Cable Length	Connector A	Connector B
415-0015-006	RG -178	6"	133-3402-101	133-3402-101
415-0015-012	RG -178	12"	133-3402-101	133-3402-101
415-0015-018	RG -178	18"	133-3402-101	133-3402-101
415-0015-024	RG -178	24"	133-3402-101	133-3402-101
415-0015-030	RG -178	30"	133-3402-101	133-3402-101
415-0015-036	RG -178	36"	133-3402-101	133-3402-101
415-0012-006	RG -316	6"	133-3403-101	133-3403-101

Part No.	Cable Type	Cable Length	Connector A	Connector B
415-0021-006	RG-316DS	6"	133-3404-101	133-3404-101
415-0021-012	RG-316DS	12"	133-3404-101	133-3404-101
415-0021-018	RG-316DS	18"	133-3404-101	133-3404-101
415-0021-024	RG-316DS	24"	133-3404-101	133-3404-101
415-0021-030	RG-316DS	30"	133-3404-101	133-3404-101
415-0021-036	RG-316DS	36"	133-3404-101	133-3404-101

### MCX 75 Ohm Straight Plug to MCX 75 Ohm Straight Plug



Part No.	Cable Type	Cable Length	Connector A	Connector B
415-0022-006	RG -179	6"	133-8433-001	133-8433-001
415-0022-012	RG -179	12"	133-8433-001	133-8433-001
415-0022-018	RG -179	18"	133-8433-001	133-8433-001
415-0022-024	RG-179	24"	133-8433-001	133-8433-001
415-0022-030	RG -179	30"	133-8433-001	133-8433-001
415-0022-036	RG -179	36"	133-8433-001	133-8433-001

Part No.	Cable Type	Cable Length	Connector A	Connector B
415-0023-006	Belden 735A	6"	133-8445-001	133-8445-001
415-0023-012	Belden 735A	12"	133-8445-001	133-8445-001
415-0023-018	Belden 735A	18"	133-8445-001	133-8445-001
415-0023-024	Belden 735A	24"	133-8445-001	133-8445-001
415-0023-030	Belden 735A	30"	133-8445-001	133-8445-001
415-0023-036	Belden 735A	36"	133-8445-001	133-8445-001

### MCX 75 Ohm Right Angle Plug to MCX 75 Ohm Right Angle Plug



Part No.	Cable Type	Cable Length	Connector A	Connector B
415-0024-006	Belden 735A	6"	133-8445-101	133-8445-101
415-0024-012	Belden 735A	12"	133-8445-101	133-8445-101
415-0024-018	Belden 735A	18"	133-8445-101	133-8445-101

Part No.	Cable Type	Cable Length	Connector A	Connector B
415-0024-024	Belden 735A	24"	133-8445-101	133-8445-101
415-0024-030	Belden 735A	30"	133-8445-101	133-8445-101
415-0024-036	Belden 735A	36"	133-8445-101	133-8445-101

### SMA Straight Plug to SMA Straight Plug



Part No.	Cable Type	Cable Length	Connector A	Connector B
415-0025-006	RG -178	6"	142-0402-011	142-0402-011
415-0025-012	RG -178	12"	142-0402-011	142-0402-011
415-0025-018	RG -178	18"	142-0402-011	142-0402-011
415-0025-024	RG -178	24"	142-0402-011	142-0402-011
415-0025-036	RG -178	36"	142-0402-011	142-0402-011
415-0025-048	RG -178	48"	142-0402-011	142-0402-011
415-0029-006	RG -316	6"	142-0403-011	142-0403-011
415-0029-012	RG -316	12"	142-0403-011	142-0403-011
415-0029-018	RG -316	18"	142-0403-011	142-0403-011
415-0029-024	RG -316	24"	142-0403-011	142-0403-011
415-0029-036	RG -316	36"	142-0403-011	142-0403-011
415-0029-048	RG -316	48"	142-0403-011	142-0403-011
415-0033-006	RG-316DS	6"	142-0404-011	142-0404-011
415-0033-012	RG-316DS	12"	142-0404-011	142-0404-011

Part No.	Cable Type	Cable Length	Connector A	Connector B
415-0033-018	RG-316DS	18"	142-0404-011	142-0404-011
415-0033-024	RG-316DS	24"	142-0404-011	142-0404-011
415-0033-036	RG-316DS	36"	142-0404-011	142-0404-011
415-0033-048	RG-316DS	48"	142-0404-011	142-0304-411
415-0038-012	RG -58	12"	142-0407-011	142-0307-411
415-0038-024	RG -58	24"	142-0407-011	142-0307-411
415-0038-036	RG -58	36"	142-0407-011	142-0307-411
415-0038-048	RG -58	48"	142-0407-011	142-0307-411
415-0038-060	RG-58	60"	142-0407-011	142-0307-411
415-0043-012	RG-142	12"	142-0408-011	142-0308-411
415-0043-024	RG-142	24"	142-0408-011	142-0308-411
415-0043-036	RG-142	36"	142-0408-011	142-0308-411
415-0043-048	RG -142	48"	142-0408-011	142-0308-411
415-0043-060	RG-142	60"	142-0408-011	142-0308-411

For more information, please contact customer service at (507) 833-8822 or (800) 247-8256 • [www.EmersonConnectivity.com](http://www.EmersonConnectivity.com)  
Illustrations are shown in inches (millimeters).

Hand Formable SMA Straight Plug to SMA Straight Plug



Part No.	Cable Type	Cable Length	Connector A	Connector B
415-0081-003	Hand Formable .086	3"	142-0693-001	142-0693-001
415-0081-004	Hand Formable .086	4"	142-0693-001	142-0693-001
415-0081-005	Hand Formable .086	5"	142-0693-001	142-0693-001
415-0081-006	Hand Formable .086	6"	142-0693-001	142-0693-001
415-0081-007	Hand Formable .086	7"	142-0693-001	142-0693-001

Part No.	Cable Type	Cable Length	Connector A	Connector B
415-0081-008	Hand Formable .086	8"	142-0693-001	142-0693-001
415-0081-012	Hand Formable .086	12"	142-0693-001	142-0693-001
415-0081-018	Hand Formable .086	18"	142-0693-001	142-0693-001
415-0081-024	Hand Formable .086	24"	142-0693-001	142-0693-001

Hand Formable SMA Straight Plug to SMA Straight Plug



Part No.	Cable Type	Cable Length	Connector A	Connector B
415-0082-003	Hand Formable .141	3"	142-0694-001	142-0694-001
415-0082-004	Hand Formable .141	4"	142-0694-001	142-0694-001
415-0082-005	Hand Formable .141	5"	142-0694-001	142-0694-001
415-0082-006	Hand Formable .141	6"	142-0694-001	142-0694-001
415-0082-007	Hand Formable .141	7"	142-0694-001	142-0694-001

Part No.	Cable Type	Cable Length	Connector A	Connector B
415-0082-008	Hand Formable .141	8"	142-0694-001	142-0694-001
415-0082-012	Hand Formable .141	12"	142-0694-001	142-0694-001
415-0082-018	Hand Formable .141	18"	142-0694-001	142-0694-001
415-0082-024	Hand Formable .141	24"	142-0694-001	142-0694-001

SMA Straight Plug to SMA Straight Bulkhead Jack



Part No.	Cable Type	Cable Length	Connector A	Connector B
415-0031-006	RG-316	6"	142-0403-011	142-0303-411
415-0031-012	RG-316	12"	142-0403-011	142-0303-411
415-0031-018	RG-316	18"	142-0403-011	142-0303-411
415-0031-024	RG-316	24"	142-0403-011	142-0303-411
415-0031-036	RG-316	36"	142-0403-011	142-0303-411
415-0031-048	RG-316	48"	142-0403-011	142-0303-411
415-0035-006	RG-316 DS	6"	142-0404-011	142-0304-411
415-0035-012	RG-316 DS	12"	142-0404-011	142-0304-411
415-0035-018	RG-316 DS	18"	142-0404-011	142-0304-411
415-0035-024	RG-316 DS	24"	142-0404-011	142-0304-411
415-0035-036	RG-316 DS	36"	142-0404-011	142-0304-411

Part No.	Cable Type	Cable Length	Connector A	Connector B
415-0035-048	RG-316 DS	48"	142-0404-011	142-0304-411
415-0040-012	RG-58	12"	142-0407-011	142-0307-411
415-0040-024	RG-58	24"	142-0407-011	142-0307-411
415-0040-036	RG-58	36"	142-0407-011	142-0307-411
415-0040-048	RG-58	48"	142-0407-011	142-0307-411
415-0040-060	RG-58	60"	142-0407-011	142-0307-411
415-0045-012	RG-142	12"	142-0408-011	142-0308-411
415-0045-024	RG-142	24"	142-0408-011	142-0308-411
415-0045-036	RG-142	36"	142-0408-011	142-0308-411
415-0045-048	RG-142	48"	142-0408-011	142-0308-411
415-0045-060	RG-142	60"	142-0408-011	142-0308-411

SMA Straight Plug to SMA Right Angle Plug



Part No.	Cable Type	Cable Length	Connector A	Connector B
415-0026-006	RG-178	6"	142-0402-011	142-0402-101
415-0026-012	RG-176	12"	142-0402-011	142-0402-101
415-0026-016	RG-178	18"	142-0402-011	142-0402-101
415-0026-024	RG-178	24"	142-0402-011	142-0402-101
415-0026-036	RG-178	36"	142-0402-011	142-0402-101
415-0026-048	RG-178	48"	142-0402-011	142-0402-101
415-0030-006	RG-316	6"	142-0403-011	142-0403-101
415-0030-012	RG-316	12"	142-0403-011	142-0403-101
415-0030-018	RG-316	18"	142-0403-011	142-0403-101
415-0030-024	RG-316	24"	142-0403-011	142-0403-101
415-0030-036	RG-316	36"	142-0403-011	142-0403-101
415-0030-048	RG-316	48"	142-0403-011	142-0403-101

Part No.	Cable Type	Cable Length	Connector A	Connector B
415-0034-006	RG-316	6"	142-0404-011	142-0404-101
415-0034-012	RG-316	12"	142-0404-011	142-0404-101
415-0034-018	RG-316	18"	142-0404-011	142-0404-101
415-0034-024	RG-316	24"	142-0404-011	142-0404-101
415-0034-036	RG-316	36"	142-0404-011	142-0404-101
415-0034-048	RG-316	48"	142-0404-011	142-0404-101
415-0044-012	RG-142	12"	142-0408-011	142-0408-101
415-0044-024	RG-142	24"	142-0408-011	142-0408-101
415-0044-036	RG-142	36"	142-0408-011	142-0408-101
415-0044-048	RG-142	48"	142-0408-011	142-0408-101
415-0044-060	RG-142	60"	142-0408-011	142-0408-101

SMA Right Angle Plug to SMA Right Angle Plug



Part No.	Cable Type	Cable Length	Connector A	Connector B
415-0027-006	RG-178	6"	142-0402-101	142-0402-101
415-0027-012	RG-178	12"	142-0402-101	142-0402-101
415-0027-018	RG-178	18"	142-0402-101	142-0402-101
415-0027-024	RG-178	24"	142-0402-101	142-0402-101
415-0027-036	RG-178	36"	142-0402-101	142-0402-101
415-0027-048	RG-178	48"	142-0402-101	142-0402-101
415-0032-006	RG-316	6"	142-0403-101	142-0403-101
415-0032-012	RG-316	12"	142-0403-101	142-0403-101
415-0032-018	RG-316	18"	142-0403-101	142-0403-101
415-0032-024	RG-316	24"	142-0403-101	142-0403-101
415-0032-036	RG-316	36"	142-0403-101	142-0403-101
415-0032-048	RG-316	48"	142-0403-101	142-0403-101
415-0036-006	RG-316 DS	6"	142-0404-101	142-0404-101
415-0036-012	RG-316 DS	12"	142-0404-101	142-0404-101

Part No.	Cable Type	Cable Length	Connector A	Connector B
415-0036-018	RG-316	18"	142-0404-101	142-0404-101
415-0036-024	RG-316	24"	142-0404-101	142-0404-101
415-0036-036	RG-316	36"	142-0404-101	142-0404-101
415-0036-048	RG-316	48"	142-0404-101	142-0404-101
415-0041-012	RG-58	12"	142-0407-101	142-0407-101
415-0041-024	RG-58	24"	142-0407-101	142-0407-101
415-0041-036	RG-58	36"	142-0407-101	142-0407-101
415-0041-048	RG-58	48"	142-0407-101	142-0407-101
415-0041-060	RG-58	60"	142-0407-101	142-0407-101
415-0046-012	RG-142	12"	142-0408-101	142-0408-101
415-0046-024	RG-142	24"	142-0408-101	142-0408-101
415-0046-036	RG-142	36"	142-0408-101	142-0408-101
415-0046-048	RG-142	48"	142-0408-101	142-0408-101
415-0046-060	RG-142	60"	142-0408-101	142-0408-101

### SMA Right Angle Plug to SMA Straight Bulkhead Jack



Part No.	Cable Type	Cable Length	Connector A	Connector B	Part No.	Cable Type	Cable Length	Connector A	Connector B
415-0074-006	RG-316	6"	142-0403-101	142-0303-411	415-0064-036	RG-316DS	36"	142-0404-101	142-0304-411
415-0074-012	RG-316	12"	142-0403-101	142-0303-411	415-0064-048	RG-316DS	48"	142-0404-101	142-0304-411
415-0074-024	RG-316	24"	142-0403-101	142-0303-411	415-0075-006	RG-142	6"	142-0406-101	142-0306-411
415-0074-036	RG-316	36"	142-0403-101	142-0303-411	415-0075-012	RG-142	12"	142-0406-101	142-0306-411
415-0074-048	RG-316	48"	142-0403-101	142-0303-411	415-0075-024	RG-142	24"	142-0406-101	142-0306-411
415-0064-006	RG-316DS	6"	142-0404-101	142-0304-411	415-0075-036	RG-142	36"	142-0406-101	142-0306-411
415-0064-012	RG-316DS	12"	142-0404-101	142-0304-411	415-0075-048	RG-142	48"	142-0406-101	142-0306-411
415-0064-024	RG-316DS	24"	142-0404-101	142-0304-411					

### Straight SMA Quick-Connect Plug to Straight SMA Quick-Connect Plug



Part No.	Cable Type	Cable Length	Connector A	Connector B	Part No.	Cable Type	Cable Length	Connector A	Connector B
415-0065-006	RG-316	6"	142-1403-001	142-1403-001	415-0076-012	RG-316DS	12"	142-1404-001	142-1404-001
415-0065-012	RG-316	12"	142-1403-001	142-1403-001	415-0076-024	RG-316DS	24"	142-1404-001	142-1404-001
415-0065-018	RG-316	18"	142-1403-001	142-1403-001	415-0076-036	RG-316DS	36"	142-1404-001	142-1404-001
415-0065-024	RG-316	24"	142-1403-001	142-1403-001	415-0077-012	RG-142	12"	142-1408-001	142-1408-001
415-0065-036	RG-316	36"	142-1403-001	142-1403-001	415-0077-024	RG-142	24"	142-1408-001	142-1408-001
415-0065-048	RG-316	48"	142-1403-001	142-1403-001	415-0077-036	RG-142	36"	142-1408-001	142-1408-001

### Straight SMA Quick-Connect Plug to Straight SMA Plug



Part No.	Cable Type	Cable Length	Connector A	Connector B	Part No.	Cable Type	Cable Length	Connector A	Connector B
415-0078-012	RG-316DS	12"	142-1404-001	142-0404-011	415-0079-012	RG-142	12"	142-1408-001	142-0408-011
415-0078-024	RG-316DS	24"	142-1404-001	142-0404-011	415-0079-024	RG-142	24"	142-1408-001	142-0408-011
415-0078-036	RG-316DS	36"	142-1404-001	142-0404-011	415-0079-036	RG-142	36"	142-1408-001	142-0408-011

### SMB Straight Plug to SMB Straight Plug



Part No.	Cable Type	Cable Length	Connector A	Connector B	Part No.	Cable Type	Cable Length	Connector A	Connector B
413-0003-000	RG-316	6"	131-1403-001	131-1403-001	413-0003-024	RG-316	24"	131-1403-001	131-1403-001
415-0003-012	RG-316	12"	131-1403-001	131-1403-001	415-0003-030	RG-316	30"	131-1403-001	131-1403-001
415-0003-018	RG-316	18"	131-1403-001	131-1403-001	415-0003-036	RG-316	36"	131-1403-001	131-1403-001

### SMB Straight Plug to SMB Right Angle Plug



Part No.	Cable Type	Cable Length	Connector A	Connector B	Part No.	Cable Type	Cable Length	Connector A	Connector B
415-0007-006	RG-178	6"	131-3462-661	131-1462-161	415-0002-024	RG-316	24"	131-1403-001	131-1403-101
415-0007-012	RG-178	12"	131-3402-001	131-1402-101	415-0002-030	RG-316	30"	131-1403-001	131-1403-101
415-0007-018	RG-178	18"	131-3462-661	131-1462-161	415-0002-036	RG-316	36"	131-1403-001	131-1403-101
415-0007-024	RG-178	24"	131-3462-661	131-1462-161	415-0005-006	RG-316 DS	6"	131-1404-001	131-1404-101
415-0007-030	RG-178	36"	131-3462-661	131-1462-161	415-0005-012	RG-316 DS	12"	131-1404-001	131-1404-101
415-0007-036	RG-178	36"	131-3462-661	131-1462-161	415-0005-018	RG-316 DS	16"	131-1404-001	131-1404-101
415-0002-006	RG-316	6"	131-1463-661	131-1463-161	415-0005-024	RG-316 DS	24"	131-1404-001	131-1404-101
415-0002-012	RG-316	12"	131-1463-661	131-1463-161	415-0005-030	RG-316 DS	30"	131-1404-001	131-1404-101
415-0002-018	RG-316	18"	131-1463-661	131-1463-161	415-0005-036	RG-316 DS	36"	131-1404-001	131-1404-101

### SMB Right Angle Plug to SMB Right Angle Plug



Part No.	Cable Type	Cable Length	Connector A	Connector B	Part No.	Cable Type	Cable Length	Connector A	Connector B
415-0001-006	RG-178	6"	131-1402-101	131-1402-101	415-0004-024	RG-316	24"	131-1403-101	131-1403-101
415-0001-012	RG-178	12"	131-1402-101	131-1402-101	415-0004-030	RG-316	30"	131-1403-101	131-1403-101
415-0001-018	RG-178	18"	131-1402-101	131-1402-101	415-0004-036	RG-316	36"	131-1403-101	131-1403-101
415-0001-024	RG-178	24"	131-1402-101	131-1402-101	415-0006-006	RG-316DS	6"	131-1404-101	131-1404-101
415-0001-030	RG-178	30"	131-1402-101	131-1402-101	415-0006-012	RG-316DS	12"	131-1404-101	131-1404-101
415-0001-036	RG-178	36"	131-1402-101	131-1402-101	415-0006-018	RG-316DS	18"	131-1404-101	131-1404-101
415-0004-006	RG-316	6"	131-1403-101	131-1403-101	415-0006-024	RG-316DS	24"	131-1404-101	131-1404-101
415-0004-012	RG-316	12"	131-1403-101	131-1403-101	415-0006-030	RG-316DS	30"	131-1404-101	131-1404-101
415-0004-018	RG-316	18"	131-1403-101	131-1403-101	415-0006-036	RG-316DS	36"	131-1404-101	131-1404-101

### SMB Mini-75 Ohm Straight Plug to SMB Mini-75 Ohm Straight Plug



Part No.	Cable Type	Cable Length	Connector A	Connector B	Part No.	Cable Type	Cable Length	Connector A	Connector B
415-0008-006	RG-179	6"	131-8403-011	131-8403-011	415-0010-006	RG-179 DS	6"	131-6404-011	131-6404-011
415-0008-012	RG-179	12"	131-8403-011	131-8403-011	415-0010-012	RG-179 DS	12"	131-6404-011	131-6404-011
415-0008-018	RG-179	18"	131-6403-011	131-6403-011	415-0010-018	RG-179 DS	18"	131-6404-011	131-6404-011
415-0008-024	RG-179	24"	131-6403-011	131-6403-011	415-0010-024	RG-179 DS	24"	131-6404-011	131-6404-011
415-0008-030	RG-179	30"	131-8403-011	131-8403-011	415-0010-030	RG-179 DS	30"	131-6404-011	131-6404-011
415-0008-036	RG-179	36"	131-8403-011	131-8403-011	415-0010-036	RG-179 DS	36"	131-6404-011	131-6404-011

For more information, please contact customer service at (507) 833-8822 or (800) 247-8256 • www.EmersonConnectivity.com  
Illustrations are shown in inches (millimeters).

### SMB Mini-75 Ohm Straight Plug to SMB Mini-75 Ohm Right Angle Plug



Part No.	Cable Type	Cable Length	Connector A	Connector B
415-0009-006	RG -179	6"	131-8403-111	131-8403-111
415-0009-012	RG -179	12"	131-8403-111	131-8403-111
415-0009-018	RG -179	18"	131-8403-111	131-8403-111
415-0009-024	RG -179	24"	131-8403-111	131-8403-111
415-0009-030	RG -179	30"	131-8403-111	131-8403-111
415-0009-036	RG -179	36"	131-8403-111	131-8403-111
415-0011-006	RG-179 DS	6"	131-8404-111	131-8404-111
415-0011-012	RG-179 DS	12"	131-8404-111	131-8404-111
415-0011-018	RG-179 DS	18"	131-8404-111	131-8404-111

Part No.	Cable Type	Cable Length	Connector A	Connector B
415-0011-024	RG-179 DS	24"	131-8404-111	131-8404-111
415-0011-030	RG-179 DS	30"	131-8404-111	131-8404-111
415-0011-036	RG-179 DS	36"	131-8404-111	131-8404-111
415-0013-006	Belden 735A	6"	131-8445-101	131-8445-101
415-0013-012	Belden 735A	12"	131-8445-101	131-8445-101
415-0013-018	Belden 735A	18"	131-8445-101	131-8445-101
415-0013-024	Belden 735A	24"	131-8445-101	131-8445-101
415-0013-030	Belden 735A	30"	131-8445-101	131-8445-101
415-0013-036	Belden 735A	36"	131-8445-101	131-8445-101

### N Straight Plug to N Straight Plug



Part No.	Cable Type	Cable Length	Connector A	Connector B
415-0058-012	RG -58	12"	CPN -1	CPN -1
415-0058-024	RG -58	24"	CPN -1	CPN -1
415-0058-036	RG -58	36"	CPN -1	CPN -1
415-0058-048	RG -58	48"	CPN -1	CPN -1
415-0058-060	RG -58	60"	CPN -1	CPN -1
415-0060-012	RG -142	12"	CPN -142T	CPN -142T
415-0060-024	RG -142	24"	CPN -142T	CPN -142T
415-0060-036	RG -142	36"	CPN -142T	CPN -142T
415-0060-048	RG -142	48"	CPN -142T	CPN -142T
415-0060-060	RG -142	60"	CPN -142T	CPN -142T

Part No.	Cable Type	Cable Length	Connector A	Connector B
415-0062-012	RG-8	12"	CPN -8	CPN -8
415-0062-024	RG-8	24"	CPN -8	CPN -8
415-0062-036	RG-8	36"	CPN -8	CPN -8
415-0062-048	RG-8	48"	CPN -8	CPN -8
415-0062-060	RG-8	60"	CPN -8	CPN -8
415-0063-012	RG -213	12"	CPN -8	CPN -8
415-0063-024	RG -213	24"	CPN -8	CPN -8
415-0063-036	RG -213	36"	CPN -8	CPN -8
415-0063-048	RG -213	48"	CPN -8	CPN -8
415-0063-060	RG -213	60"	CPN -8	CPN -8

### BNC Straight Plug to BNC Straight Plug



Part No.	Cable Type	Cable Length	Connector A	Connector B
415-0054-012	RG -58	12"	CPMC-88-1	CPMC-88-1
415-0054-024	RG -58	24"	CPMC-88-1	CPMC-88-1
415-0054-036	RG-58	36"	CPMC-88-1	CPMC-88-1
415-0054-048	RG -58	48"	CPMC-88-1	CPMC-88-1
415-0054-060	RG -58	60"	CPMC-88-1	CPMC-88-1
415-0057-012	RG-59	12"	CPMC-88-2	CPMC-88-2
415-0057-024	RG-59	24"	CPMC-88-2	CPMC-88-2
415-0057-036	RG-59	36"	CPMC-88-2	CPMC-88-2
415-0057-048	RG-59	48"	CPMC-88-2	CPMC-88-2

Part No.	Cable Type	Cable Length	Connector A	Connector B
415-0056-012+	Belden 8218	12"	CPMC-88-18	CPMC-88-18
415-0056-024+	Belden 8218	24"	CPMC-88-18	CPMC-88-18
415-0056-036+	Belden 8218	36"	CPMC-88-18	CPMC-88-18
415-0056-048+	Belden 8218	48"	CPMC-88-18	CPMC-88-18
415-0056-060+	Belden 8218	60"	CPMC-88-18	CPMC-88-18

+ with Heat Shrink

### 75 Ohm BNC Straight Plug to 75 Ohm BNC Straight Plug



Part No.	Cable Type	Cable Length	Connector A	Connector B
415-0048-012	RG -59	12"	CPMC-68-2	CPMC-68-2
415-0048-024	RG -59	24"	CPMC-68-2	CPMC-68-2
415-0048-036	RG-59	36"	CPMC-68-2	CPMC-68-2
415-0048-048	RG -59	48"	CPMC-68-2	CPMC-68-2
415-0048-060	RG -59	60"	CPMC-68-2	CPMC-68-2
415-0052-012	Belden 734A	12"	CPMC-68-35	CPMC-68-35
415-0052-024	Belden 734A	24"	CPMC-68-35	CPMC-68-35
415-0052-036	Belden 734A	36"	CPMC-68-35	CPMC-68-35
415-0052-048	Belden 734A	48"	CPMC-68-35	CPMC-68-35
415-0052-060	Belden 734A	60"	CPMC-68-35	CPMC-68-35

### SMA Straight Plug to BNC Straight Plug



Part No.	Cable Type	Cable Length	Connector A	Connector B
415-0028-006	RG -316	6"	142-0403-011	CPM -88-19
415-0028-012	RG -316	12"	142-0403-011	CPM -88-19
415-0028-018	RG -316	18"	142-0403-011	CPM -88-19
415-0028-024	RG -316	24"	142-0403-011	CPM -88-19
415-0028-036	RG -316	36"	142-0403-011	CPM -88-19
415-0028-048	RG -316	48"	142-0403-011	CPM -88-19
415-0037-012	RG -58	12"	142-0407-011	CPMC-88-1
415-0037-024	RG -58	24"	142-0407-011	CPMC-88-1

### SMA Straight Plug to N Straight Plug



Part No.	Cable Type	Cable Length	Connector A	Connector B
415-0059-012	RG -58	12"	142-0407-011	CPN -1
415-0059-024	RG -58	24"	142-0407-011	CPN -1
415-0059-036	RG -58	36"	142-0407-011	CPN -1
415-0059-048	RG -58	48"	142-0407-011	CPN -1
415-0059-060	RG -58	60"	142-0407-011	CPN -1

Part No.	Cable Type	Cable Length	Connector A	Connector B
415-0047-012	Belden 8218	12"	CPMC-68-18	CPMC-58-18
415-0047-024	Belden 8218	24"	CPMC-68-18	CPMC-68-18
415-0047-036	Belden 8218	36"	CPMC-68-18	CPMC-68-18
415-0047-048	Belden 8218	48"	CPMC-68-18	CPMC-68-18
415-0047-060	Belden 8218	60"	CPMC-68-18	CPMC-68-18
415-0049-012	Belden 8281	12"	CPMC-68-3	CPMC-68-3
415-0049-024	Belden 8281	24"	CPMC-68-3	CPMC-68-3
415-0049-036	Belden 8281	36"	CPMC-68-3	CPMC-68-3
415-0049-048	Belden 8281	48"	CPMC-68-3	CPMC-68-3
415-0049-060	Belden 8281	60"	CPMC-68-3	CPMC-68-3
415-0050-012	Comm Scope 735	12"	CPMC-68-33	CPMC-68-33
415-0050-024	Comm Scope 735	24"	CPMC-68-33	CPMC-68-33
415-0050-036	Comm Scope 735	36"	CPMC-68-33	CPMC-68-33
415-0050-048	Comm Scope 735	48"	CPMC-68-33	CPMC-68-33
415-0050-060	Comm Scope 735	60"	CPMC-68-33	CPMC-68-33
415-0051-012	Belden 735A	12"	CPMC-68-33	CPMC-68-33
415-0051-024	Belden 735A	24"	CPMC-68-33	CPMC-68-33
415-0051-036	Belden 735A	36"	CPMC-68-33	CPMC-68-33
415-0051-048	Belden 735A	48"	CPMC-68-33	CPMC-68-33
415-0051-060	Belden 735A	60"	CPMC-68-33	CPMC-68-33
415-0053-012	Belden 1694A	12"	CPMC-68-45	CPMC-68-45
415-0053-024	Belden 1694A	24"	CPMC-68-45	CPMC-68-45
415-0053-036	Belden 1694A	36"	CPMC-68-45	CPMC-68-45
415-0053-048	Belden 1694A	48"	CPMC-68-45	CPMC-68-45
415-0053-060	Belden 1694A	60"	CPMC-68-45	CPMC-68-45

Part No.	Cable Type	Cable Length	Connector A	Connector B
415-0037-036	RG-58	36"	142-0407-011	CPMC-88-1
415-0037-048	RG -58	48"	142-0407-011	CPMC-88-1
415-0037-060	RG -58	60"	142-0407-011	CPMC-88-1
415-0042-012	RG -142	12"	142-0408-011	CPMC-88-13
415-0042-024	RG -142	24"	142-0408-011	CPMC-88-13
415-0042-036	RG -142	36"	142-0408-011	CPMC-88-13
415-0042-048	RG -142	48"	142-0408-011	CPMC-88-13
415-0042-060	RG -142	60"	142-0408-011	CPMC-88-13

For more information, please contact customer service at (507) 833-8822 or (800) 247-8256 • www.EmersonConnectivity.com

Illustrations are shown in inches (millimeters).



kwiQMate™ Straight to Straight

Part No.	Cable Type	Cable Length	Connector A	Connector B	Part No.	Cable Type	Cable Length	Connector A	Connector B
415-0162-006	RG-316DS	6"	146-0404-007	146-0404-007	415-0163-006	RG-316	6"	146-0403-007	146-0403-007
415-0162-012	RG-316DS	12"	146-0404-007	146-0404-007	415-0163-012	RG-316	12"	146-0403-007	146-0403-007
415-0162-024	RG-316DS	24"	146-0404-007	146-0404-007	415-0163-024	RG-316	24"	146-0403-007	146-0403-007
415-0162-036	RG-316DS	36"	146-0404-007	146-0404-007	415-0163-036	RG-316	36"	146-0403-007	146-0403-007
415-0162-048	RG-316DS	48"	146-0404-007	146-0404-007	415-0163-048	RG-316	48"	146-0403-007	146-0403-007



kwiQMate™ Straight to Right Angle

Part No.	Cable Type	Cable Length	Connector A	Connector B	Part No.	Cable Type	Cable Length	Connector A	Connector B
415-0171-006	RG-316DS	6"	146-0404-007	146-0404-107	415-0172-006	RG-316	6"	146-0403-007	146-0403-107
415-0171-012	RG-316DS	12"	146-0404-007	146-0404-107	415-0172-012	RG-316	12"	146-0403-007	146-0403-107
415-0171-024	RG-316DS	24"	146-0404-007	146-0404-107	415-0172-024	RG-316	24"	146-0403-007	146-0403-107
415-0171-036	RG-316DS	36"	146-0404-007	146-0404-107	415-0172-036	RG-316	36"	146-0403-007	146-0403-107
415-0171-048	RG-316DS	48"	146-0404-007	146-0404-107	415-0172-048	RG-316	48"	146-0403-007	146-0403-107



kwiQMate™ Right Angle to Right Angle

Part No.	Cable Type	Cable Length	Connector A	Connector B	Part No.	Cable Type	Cable Length	Connector A	Connector B
415-0174-006	RG-316DS	6"	146-0404-107	146-0404-107	415-0175-006	RG-316	6"	146-0403-107	146-0403-107
415-0174-012	RG-316DS	12"	146-0404-107	146-0404-107	415-0175-012	RG-316	12"	146-0403-107	146-0403-107
415-0174-024	RG-316DS	24"	146-0404-107	146-0404-107	415-0175-024	RG-316	24"	146-0403-107	146-0403-107
415-0174-036	RG-316DS	36"	146-0404-107	146-0404-107	415-0175-036	RG-316	36"	146-0403-107	146-0403-107
415-0174-048	RG-316DS	48"	146-0404-107	146-0404-107	415-0175-048	RG-316	48"	146-0403-107	146-0403-107



kwiQMate™ Straight to SMA Straight

Part No.	Cable Type	Cable Length	Connector A	Connector B	Part No.	Cable Type	Cable Length	Connector A	Connector B
415-0165-006	RG-316DS	6"	146-0404-007	142-0404-016	415-0166-006	RG-316	6"	146-0403-007	142-0403-016
415-0165-012	RG-316DS	12"	146-0404-007	142-0404-016	415-0166-012	RG-316	12"	146-0403-007	142-0403-016
415-0165-024	RG-316DS	24"	146-0404-007	142-0404-016	415-0166-024	RG-316	24"	146-0403-007	142-0403-016
415-0165-036	RG-316DS	36"	146-0404-007	142-0404-016	415-0166-036	RG-316	36"	146-0403-007	142-0403-016
415-0165-048	RG-316DS	48"	146-0404-007	142-0404-016	415-0166-048	RG-316	48"	146-0403-007	142-0403-016

Ultra Miniature Cable Assemblies

MMCX Cable Assemblies  
 Specification ..... 174  
 UMC to UMC ..... 174  
 UMC to MMCX ..... 175  
 UMC to SMA ..... 176  
 Pigtail Cable ..... 178  
 UMC Surface Mount Connector ..... 179  
 Pigtail Cable Adapters ..... 180

Other Information  
 Assembly Tools ..... 185  
 Capabilities ..... 190  
 Cable Information ..... 192  
 Assembly Instruction ..... 193  
 Mounting Hole Layouts ..... 194  
 Numerical Index ..... 274  
 Competitor Cross Reference ..... 280

3 **MMCX Connectors**

13 **MCX Connectors**

39 **SMK Connectors**

45 **SMA Connectors**

103 **SMB Connectors**

131 **SMC Connectors**

137 **SMP Connectors**

145 **Type N Connectors**

153 **Shielded Cable Terminations**

157 **Between-Series Adapters**

161 **Fixed Length Cable Assemblies**

173 **Ultra Miniature Connectors (UMC)**

181 **kwiQMate™ Connectors**

185 **Tools**

193 **Assembly Instructions**

257 **Electronic Hardware**

274 **Index**

While every precaution has been taken to ensure accuracy and completeness herein, Emerson Network Power Connectivity Solutions assumes no responsibility, and disclaims all liability for damages resulting from use of this information or for any errors or omissions. Specifications subject to change without notice.

# Specifications

- Impedance:** 50 Ω (Nominal)
- Temperature Range:** -40°C to +90°C
- Frequency Rating:** 0-6 GHz
- VSWR:** 1.30 max (0-6 GHz)
- Contact Resistance:** 20 mΩ max. (Center)  
20 mΩ max. (Outer, for plug)  
10 mΩ max. (Outer, for receptacle)
- Withstanding Voltage:** 200 V AC
- Insulation Resistance:** 500 MΩ min.
- Durability:** 30 cycles
- Holding Force (min.):** 0.15 N (Female contact)

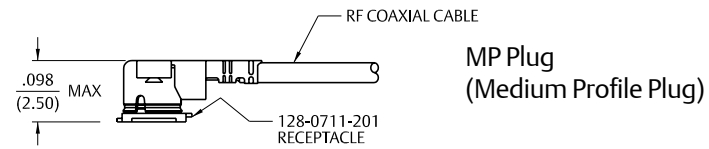
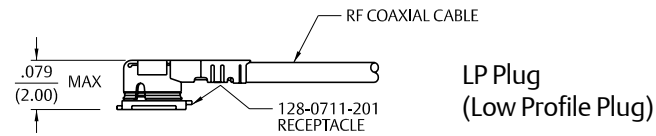

## Low Profile UMC Right Angle Cable Plug to UMC Right Angle Cable Plug



Part No.	Teflon Coaxial Cable O.D.	Cable Length	Connector A	Plug Mated Height	Connector B
415-0084-050	0.81 mm	50 mm	UMC LP PLUG	2.0 mm	UMC LP PLUG
415-0084-100	0.81 mm	100 mm	UMC LP PLUG	2.0 mm	UMC LP PLUG
415-0084-150	0.81 mm	150 mm	UMC LP PLUG	2.0 mm	UMC LP PLUG
415-0084-200	0.81 mm	200 mm	UMC LP PLUG	2.0 mm	UMC LP PLUG
415-0084-250	0.81 mm	250 mm	UMC LP PLUG	2.0 mm	UMC LP PLUG
415-0084-300	0.81 mm	300 mm	UMC LP PLUG	2.0 mm	UMC LP PLUG
415-0084-500	0.81 mm	500 mm	UMC LP PLUG	2.0 mm	UMC LP PLUG

## Medium Profile UMC Right Angle Cable Plug to UMC Right Angle Cable Plug



Part No.	Teflon Coaxial Cable O.D.	Cable Length	Connector A	Plug Mated Height	Connector B
415-0085-050	0.81 mm	50 mm	UMC MP PLUG	2.5 mm	UMC MP PLUG
415-0085-100	0.81 mm	100 mm	UMC MP PLUG	2.5 mm	UMC MP PLUG
415-0085-150	0.81 mm	150 mm	UMC MP PLUG	2.5 mm	UMC MP PLUG
415-0085-200	0.81 mm	200 mm	UMC MP PLUG	2.5 mm	UMC MP PLUG
415-0085-250	0.81 mm	250 mm	UMC MP PLUG	2.5 mm	UMC MP PLUG
415-0085-300	0.81 mm	300 mm	UMC MP PLUG	2.5 mm	UMC MP PLUG
415-0085-500	0.81 mm	500 mm	UMC MP PLUG	2.5 mm	UMC MP PLUG
415-0086-050	1.13 mm	50 mm	UMC MP PLUG	2.5 mm	UMC MP PLUG
415-0086-100	1.13 mm	100 mm	UMC MP PLUG	2.5 mm	UMC MP PLUG
415-0086-150	1.13 mm	150 mm	UMC MP PLUG	2.5 mm	UMC MP PLUG
415-0086-200	1.13 mm	200 mm	UMC MP PLUG	2.5 mm	UMC MP PLUG
415-0086-250	1.13 mm	250 mm	UMC MP PLUG	2.5 mm	UMC MP PLUG
415-0086-300	1.13 mm	300 mm	UMC MP PLUG	2.5 mm	UMC MP PLUG
415-0086-500	1.13 mm	500 mm	UMC MP PLUG	2.5 mm	UMC MP PLUG
415-0087-050	1.32 mm	50 mm	UMC MP PLUG	2.5 mm	UMC MP PLUG
415-0087-100	1.32 mm	100 mm	UMC MP PLUG	2.5 mm	UMC MP PLUG
415-0087-150	1.32 mm	150 mm	UMC MP PLUG	2.5 mm	UMC MP PLUG
415-0087-200	1.32 mm	200 mm	UMC MP PLUG	2.5 mm	UMC MP PLUG
415-0087-250	1.32 mm	250 mm	UMC MP PLUG	2.5 mm	UMC MP PLUG
415-0087-300	1.32 mm	300 mm	UMC MP PLUG	2.5 mm	UMC MP PLUG
415-0087-500	1.32 mm	500 mm	UMC MP PLUG	2.5 mm	UMC MP PLUG
415-0088-050	1.37 mm	50 mm	UMC MP PLUG	2.5 mm	UMC MP PLUG
415-0088-100	1.37 mm	100 mm	UMC MP PLUG	2.5 mm	UMC MP PLUG
415-0088-150	1.37 mm	150 mm	UMC MP PLUG	2.5 mm	UMC MP PLUG
415-0088-200	1.37 mm	200 mm	UMC MP PLUG	2.5 mm	UMC MP PLUG
415-0088-250	1.37 mm	250 mm	UMC MP PLUG	2.5 mm	UMC MP PLUG
415-0088-300	1.37 mm	300 mm	UMC MP PLUG	2.5 mm	UMC MP PLUG
415-0088-500	1.37 mm	500 mm	UMC MP PLUG	2.5 mm	UMC MP PLUG

## UMC Right Angle Cable Plug to MMCX Right Angle Plug



### Low Profile



Part No.	Teflon Coaxial Cable O.D.	Cable Length	Connector A	Plug Mated Height	Connector B
415-0101-150	0.81 mm	150 mm	UMC LP PLUG	2.0 mm	MMCX RA PLUG
415-0101-250	0.81 mm	250 mm	UMC LP PLUG	2.0 mm	MMCX RA PLUG

### Medium Profile



Part No.	Teflon Coaxial Cable O.D.	Cable Length	Connector A	Plug Mated Height	Connector B
415-0102-150	0.81 mm	150 mm	UMC LP PLUG	2.5 mm	MMCX RA PLUG
415-0102-250	0.81 mm	250 mm	UMC LP PLUG	2.5 mm	MMCX RA PLUG



## SMA Cable Assembly

### UMC Right Angle Cable Plug to SMA Straight Plug



#### Low Profile

Part No.	Teflon Coaxial Cable O.D.	Cable Length	Connector A	Plug Mated Height	Connector B
415-0089-150	0.81 mm	150 mm	UMC LP PLUG	2.0 mm	SMA STR. PLUG
415-0089-250	0.81 mm	250 mm	UMC LP PLUG	2.0 mm	SMA STR. PLUG

#### Medium Profile



Part No.	Teflon Coaxial Cable O.D.	Cable Length	Connector A	Plug Mated Height	Connector B
415-0090-150	0.81 mm	150 mm	UMC MP PLUG	2.5 mm	SMA STR. PLUG
415-0090-250	0.81 mm	250 mm	UMC MP PLUG	2.5 mm	SMA STR. PLUG
415-0091-150	1.37 mm	150 mm	UMC MP PLUG	2.5 mm	SMA STR. PLUG
415-0091-250	1.37 mm	250 mm	UMC MP PLUG	2.5 mm	SMA STR. PLUG

### UMC Right Angle Cable Plug to SMA Bulkhead Straight Jack



#### Low Profile



Part No.	Teflon Coaxial Cable O.D.	Cable Length	Connector A	Plug Mated Height	Connector B
415-0095-150	0.81 mm	150 mm	UMC LP PLUG	2.0 mm	SMA STR BKHD. JACK
415-0095-250	0.81 mm	250 mm	UMC LP PLUG	2.0 mm	SMA STR BKHD. JACK

#### Medium Profile



Part No.	Teflon Coaxial Cable O.D.	Cable Length	Connector A	Plug Mated Height	Connector B
415-0096-150	0.81 mm	150 mm	UMC MP PLUG	2.5 mm	SMA STR BKHD. JACK
415-0096-250	0.81 mm	250 mm	UMC MP PLUG	2.5 mm	SMA STR BKHD. JACK
415-0097-150	1.37 mm	150 mm	UMC MP PLUG	2.5 mm	SMA STR BKHD. JACK
415-0097-250	1.37 mm	250 mm	UMC MP PLUG	2.5 mm	SMA STR BKHD. JACK

## SMA Reverse Polarity Cable Assembly

### UMC Right Angle Cable Plug to SMA Straight Reverse Polarity Plug



#### Low Profile

Part No.	Teflon Coaxial Cable O.D.	Cable Length	Connector A	Plug Mated Height	Connector B
415-0092-150	0.81 mm	150 mm	UMC LP PLUG	2.0 mm	SMA STR. RP PLUG
415-0092-250	0.81 mm	250 mm	UMC LP PLUG	2.0 mm	SMA STR. RP PLUG

#### Medium Profile



Part No.	Teflon Coaxial Cable O.D.	Cable Length	Connector A	Plug Mated Height	Connector B
415-0093-150	0.81 mm	150 mm	UMC MP PLUG	2.5 mm	SMA STR. RP PLUG
415-0093-250	0.81 mm	250 mm	UMC MP PLUG	2.5 mm	SMA STR. RP PLUG
415-0094-150	1.37 mm	150 mm	UMC MP PLUG	2.5 mm	SMA STR. RP PLUG
415-0094-250	1.37 mm	250 mm	UMC MP PLUG	2.5 mm	SMA STR. RP PLUG

### UMC Right Angle Cable Plug to SMA Straight Bulkhead Rev. Polarity Jack



#### Low Profile



Part No.	Teflon Coaxial Cable O.D.	Cable Length	Connector A	Plug Mated Height	Connector B
415-0098-150	0.81 mm	150 mm	UMC LP PLUG	2.0 mm	SMA STR BKHD. RP JACK
415-0098-250	0.81 mm	250 mm	UMC LP PLUG	2.0 mm	SMA STR BKHD. RP JACK

#### Medium Profile



Part No.	Teflon Coaxial Cable O.D.	Cable Length	Connector A	Plug Mated Height	Connector B
415-0099-150	0.81 mm	150 mm	UMC MP PLUG	2.5 mm	SMA STR BKHD. RP JACK
415-0099-250	0.81 mm	250 mm	UMC MP PLUG	2.5 mm	SMA STR BKHD. RP JACK
415-0100-150	1.37 mm	150 mm	UMC MP PLUG	2.5 mm	SMA STR BKHD. RP JACK
415-0100-250	1.37 mm	250 mm	UMC MP PLUG	2.5 mm	SMA STR BKHD. RP JACK

# Pigtail Cable Assembly

0.81 mm Coaxial Cable

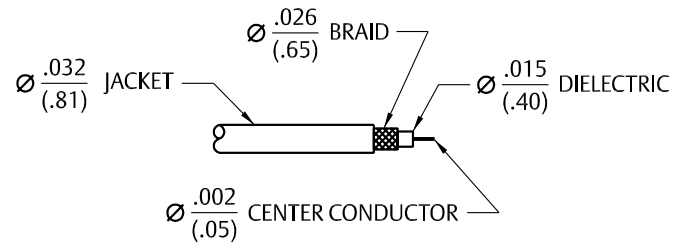

1.32 mm Coaxial Cable

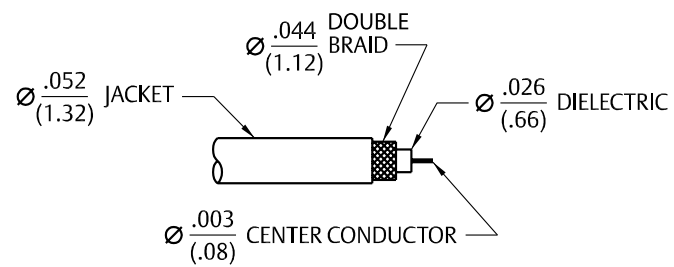

1.13 mm Coaxial Cable

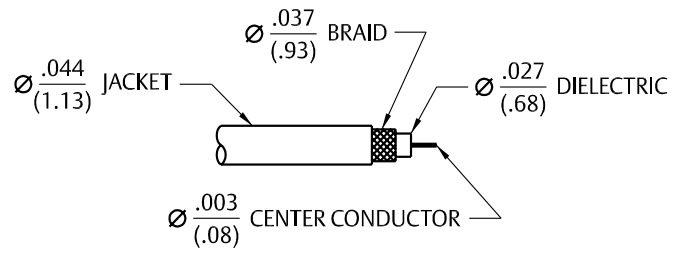

1.37 mm Coaxial Cable

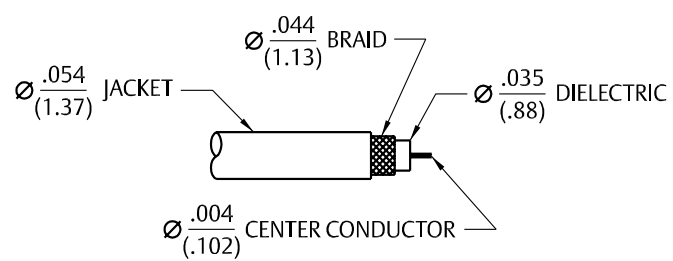

## UMC Right Angle Cable Plug to Bare End

### Low Profile



Part No.	Teflon Coaxial Cable O.D.	Cable Length	Connector A	Plug Mated Height	Connector B
415-0104-150	0.81 mm	150 mm	UMC LP PLUG	2.0 mm	BARE END
415-0104-250	0.81 mm	250 mm	UMC LP PLUG	2.0 mm	BARE END

### Medium Profile



Part No.	Teflon Coaxial Cable O.D.	Cable Length	Connector A	Plug Mated Height	Connector B
415-0105-150	0.81 mm	150 mm	UMC MP PLUG	2.5 mm	BARE END
415-0105-250	0.81 mm	250 mm	UMC MP PLUG	2.5 mm	BARE END
415-0106-150	1.13 mm	150 mm	UMC MP PLUG	2.5 mm	BARE END
415-0106-250	1.13 mm	250 mm	UMC MP PLUG	2.5 mm	BARE END
415-0107-150	1.32 mm	150 mm	UMC MP PLUG	2.5 mm	BARE END
415-0107-250	1.32 mm	250 mm	UMC MP PLUG	2.5 mm	BARE END
415-0108-150	1.37 mm	150 mm	UMC MP PLUG	2.5 mm	BARE END
415-0108-250	1.37 mm	250 mm	UMC MP PLUG	2.5 mm	BARE END

## Straight Jack Receptable – Surface Mount



Part No.	Packaging
128-0711-201	Stock
128-0711-202	Tape & Reel 2,500 pcs/reel

## Tape and Reel Specifications

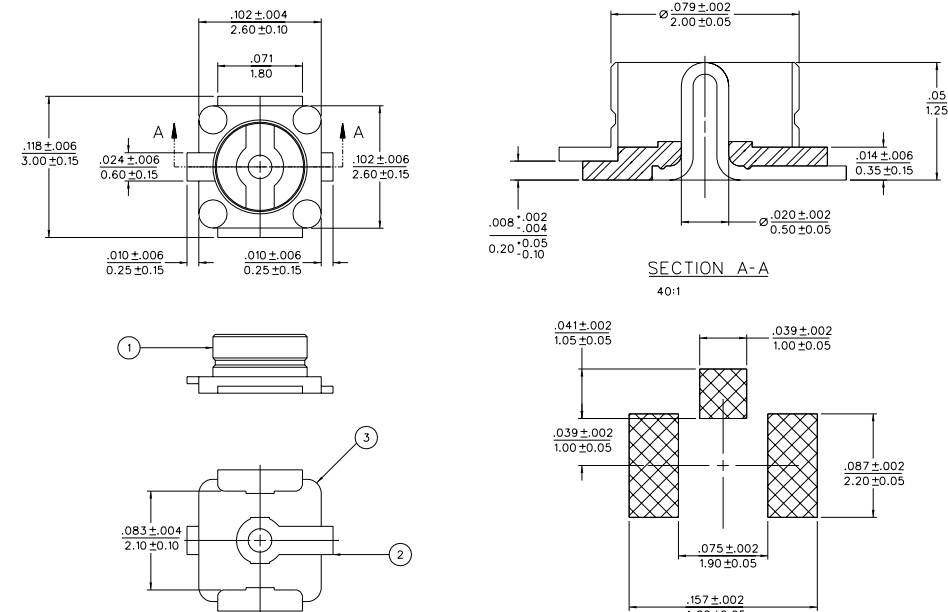
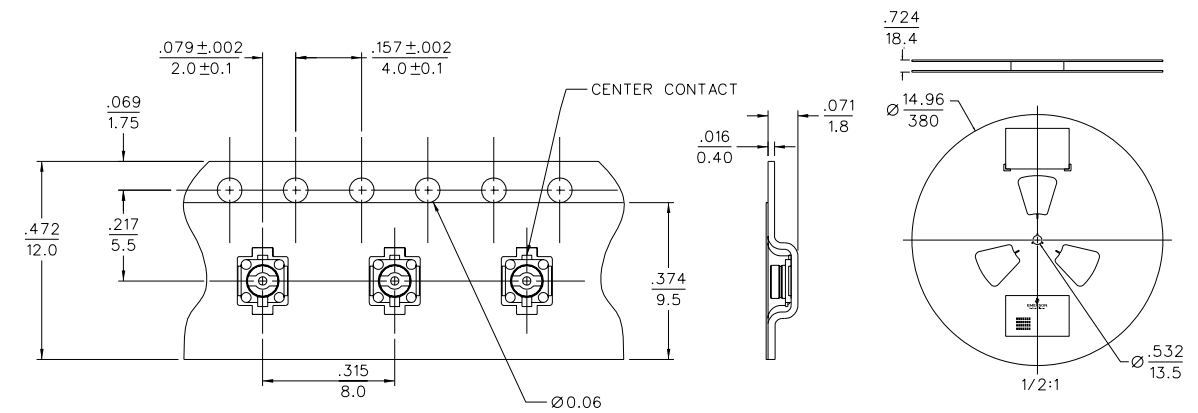

For more information, please contact customer service at (507) 833-8822 or (800) 247-8256 • [www.EmersonConnectivity.com](http://www.EmersonConnectivity.com)

Illustrations are shown in inches (millimeters).

3	MMCX Connectors
13	MCX Connectors
39	SMK Connectors
45	SMA Connectors
103	SMB Connectors
131	SMC Connectors
137	SMP Connectors
145	Type N Connectors
153	Shielded Cable Terminations
157	Between-Series Adapters
161	Fixed Length Cable Assemblies
173	Ultra Miniature Connectors (UMC)
181	kwiQMAte™ Connectors
185	Tools
193	Assembly Instructions
257	Electronic Hardware
274	Index

## Pigtail Assembly Adapters

### SMA Conversion Adapter for Mating UMC Plugs (SMA Plug to UMC Jack)



**Part No.**  
134-1019-361

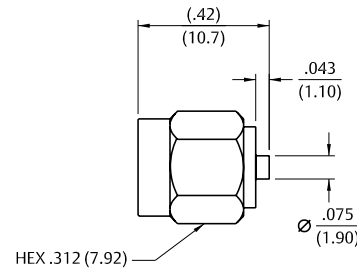

### SMA Conversion Adapter for Surface Mt. Jack Receptacle 128-0711-201 (SMA Jack to UMC Plug)



**Part No.**  
134-1019-371

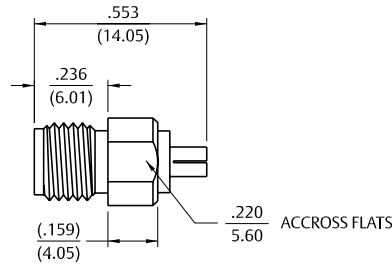

### Inspection Tool for Cable Assembly



**Part No.**  
134-1019-381

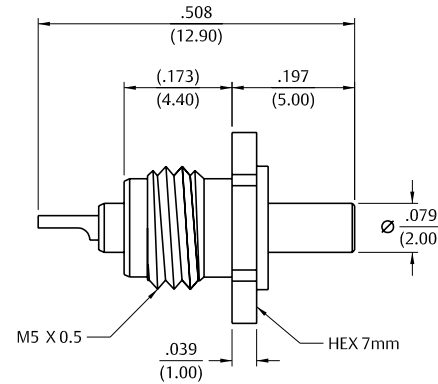

### UMC Separation Key



**Part No.**  
128-0000-901

### kwiQMAte™ Connectors

Specification .....	182
Semi-Rigid & Flexible Cable .....	184
PC Mount .....	184
Other Information	
Assembly Tools .....	185
Capabilities .....	190
Cable Information .....	192
Assembly Instruction .....	193
Mounting Hole Layouts .....	194
Numerical Index .....	274
Competitor Cross Reference .....	280

While every precaution has been taken to ensure accuracy and completeness herein, Emerson Network Power Connectivity Solutions assumes no responsibility, and disclaims all liability for damages resulting from use of this information or for any errors or omissions. Specifications subject to change without notice.

## Electrical Specifications

**Impedance:** 50 Ohms  
**Frequency Range:** 12.4 GHz

**VSWR:** (f = GHz)

	Straight Cable Connectors	Right Angle Cable Connectors
RG-316, RG-316 DS	1.15+.02f	1.15+.03f
Uncabled receptacles	N/A	

**Working Voltage:** (VRMS max)

	Sea Level	70K Feet
RG-316, RG-316 DS	250	65
Uncabled receptacles	335	85

**Dielectric Withstanding Voltage:** VRMS min (at sea level)

Connectors for RG-316, RG-316 DS	750
Uncabled receptacles	1000

**Insulation Resistance:** 5000 Megohms min

**Contact Resistance:** (milliohms max)

	Initial	After Environmental
Center contact (straight cabled connectors and Uncabled receptacles)	3.0	4.0
Center contact (right angle cabled connectors)	4.0	6.0
Outer Contact (all connectors)	2.0	N/A
Braid to Body (Tri-Alloy plated bodies)	3.0	N/A
Braid to Body (gold plated bodies)	0.5	N/A

**Corona Level:** (Volts min at 70,000 feet)

Connectors for RG-316, RG-316 DS	190
Uncabled receptacles	250

**Insertion Loss:** (dB max)

Straight flexible cable connectors	0.06	$f\sqrt{\text{GHz}}$ , tested at 6 GHz
Right angle flexible cable connectors	0.15	$f\sqrt{\text{GHz}}$ , tested at 6 GHz
Uncabled receptacles	N/A	

**RF Leakage:** (dB max, tested at 3 GHz)

Cable connectors	-80
Uncabled receptacles	N/A

**RF High Potential Withstanding Voltage:** (Vrms min, tested at 4 and 7 MHz)

Connectors for RG-316, RG-316 DS	500
Uncabled receptacles	670

## Mechanical Specifications

**Engagement Design:**  
**Durability:** 500 cycles min  
**Engagement/Disengagement Force:** 8 lbs max (5 lbs typical)  
**Coupling Retention Force:** 10 lbs min  
**Contact Retention:** 6 lbs min axial force (captivated contacts)  
 4 oz-in min torque (uncabled receptacles)

**Cable Retention:** (min\*)

	Axial Force (lbs)	Torque (oz-in)
Connectors for RG-316, RG-316 DS	20	N/A

\* Or cable breaking strength, whichever is less

## Material Specifications

**Bodies:** Brass per QQ-B-626, Tri-Alloy (Cu/Sn/Zn) plated .0001" min  
**Contacts:** Male - Brass per ASTM B16, Gold plated\* per MIL-G-45204 .00005" min  
 Female - Beryllium Copper per ASTM B196, Gold plated\* per MIL-G-45204 .00005" min  
**Insulators:** PTFE Fluorocarbon per ASTM D1710 and ASTM D1457  
**Gaskets:** Silicon Rubber per ZZ-R-765  
**Expansion Caps:** Brass per QQ-B-613, Tri-Alloy (Cu/Sn/Zn) plated .0001" min  
**Crimp Sleeves:** Copper per ASTM A75, Tri-Alloy (Cu/Sn/Zn) plated .0001" min  
**Coupling Retention Spring (Plugs):** Beryllium Copper per ASTM B196, Tri-Alloy (Cu/Sn/Zn) plated .0001" min  
**Mounting Hardware:** Brass per QQ-B-626, or QQ-B 613, Tri-Alloy (Cu/Sn/Zn) plated .0001" min

\* Gold plated parts include a .00005" min nickel barrier layer

## Environmental Specifications

(Meets or Exceeds the Applicable Paragraph of MIL-PRF-39012)

**Temperature Range:** -65°C to +165°C  
**Thermal Shock:** MIL-STD-202, Method 107, Condition B (except +85°C high temperature)  
**Corrosion:** MIL-STD-202, Method 101, Condition B  
**Shock:** MIL-STD-202, Method 213, Condition I  
**Vibration:** MIL-STD-202, Method 204, Condition D  
**Moisture Resistance:** MIL-STD-202, Method 106

### MATING ENGAGEMENT FOR kwiQMate™

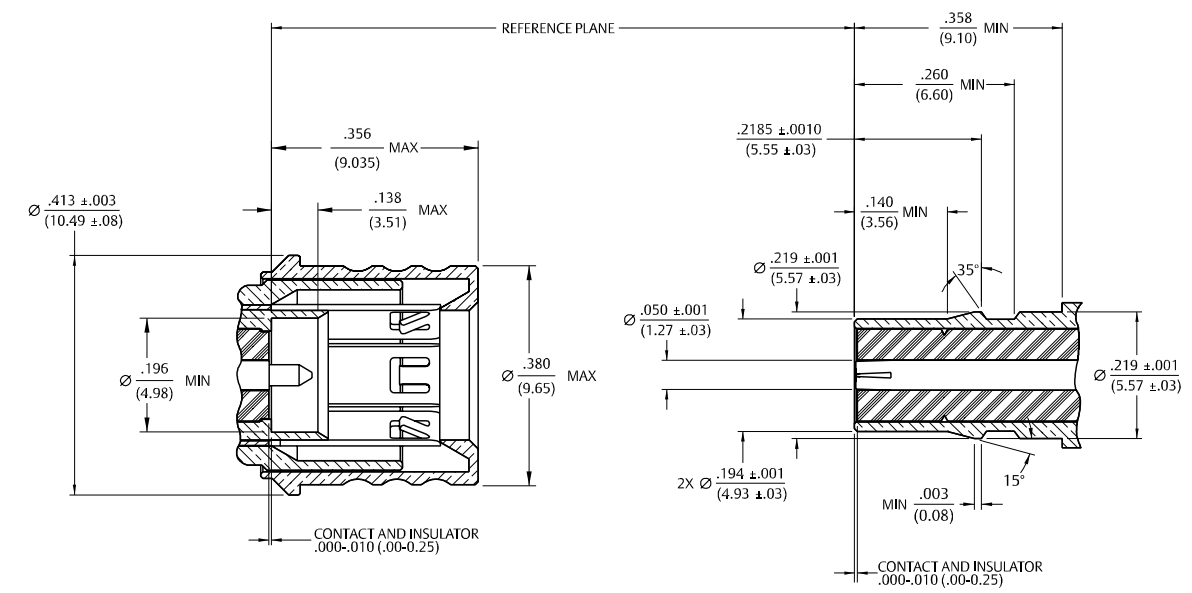

PLUG JACK

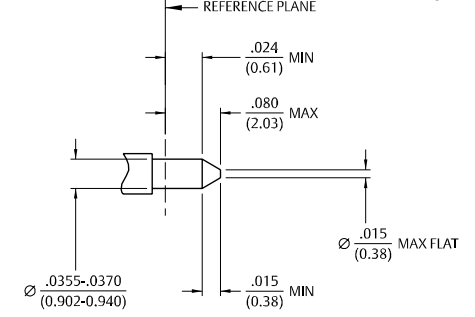

For more information, please contact customer service at (507) 833-8822 or (800) 247-8256 • www.EmersonConnectivity.com

Illustrations are shown in inches (millimeters).

### Straight Crimp Type Plug (3-piece) – Captivated Contact

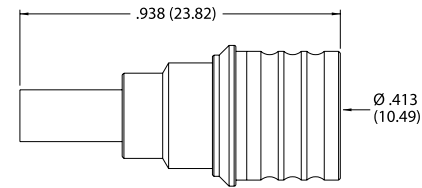

Cable Type	Tri-Alloy Plated
RG-316	146-0403-007
RG-316 DS	146-0404-007

Assembly instructions page 256.

### Right Angle Crimp Type Plug (1-piece body) – Captivated Contact

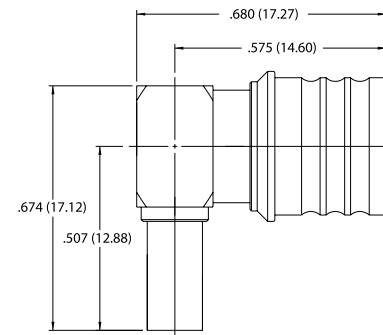

Cable Type	Tri-Alloy Plated
RG-316	146-0403-107
RG-316 DS	146-0404-107

Assembly instructions page 255.

### Straight Jack Receptacle

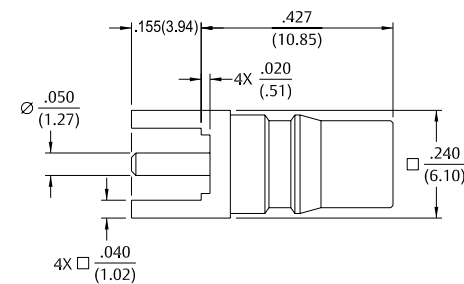

Gold Plated
146-0701-201

Mounting hole layout figure 2 page 194.

### Right Angle Jack Receptacle

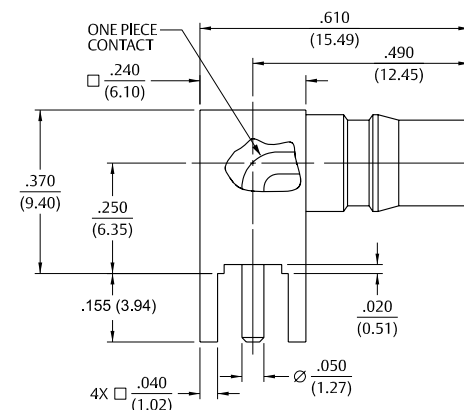

Gold Plated
146-0701-301

Mounting hole layout figure 2 page 194.

### Tools

Other Information

Assembly Tools .....	185
Capabilities .....	190
Cable Information .....	192
Assembly Instruction .....	193
Mounting Hole Layouts .....	194
Numerical Index .....	274
Competitor Cross Reference .....	280

<b>3</b>	<b>MMCX Connectors</b>
<b>13</b>	<b>MCX Connectors</b>
<b>39</b>	<b>SMK Connectors</b>
<b>45</b>	<b>SMA Connectors</b>
<b>103</b>	<b>SMB Connectors</b>
<b>131</b>	<b>SMC Connectors</b>
<b>137</b>	<b>SMP Connectors</b>
<b>145</b>	<b>Type N Connectors</b>
<b>153</b>	<b>Shielded Cable Terminations</b>
<b>157</b>	<b>Between-Series Adapters</b>
<b>161</b>	<b>Fixed Length Cable Assemblies</b>
<b>173</b>	<b>Ultra Miniature Connectors (UMC)</b>
<b>181</b>	<b>kwiQMAte™ Connectors</b>
<b>185</b>	<b>Tools</b>
<b>193</b>	<b>Assembly Instructions</b>
<b>257</b>	<b>Electronic Hardware</b>
<b>274</b>	<b>Index</b>

While every precaution has been taken to ensure accuracy and completeness herein, Emerson Network Power Connectivity Solutions assumes no responsibility, and disclaims all liability for damages resulting from use of this information or for any errors or omissions. Specifications subject to change without notice.

# Coaxial Connector Assembly Tools

## Hand Crimp Tool

Precision Astro Tool hand crimping tool makes cable assembly fast and easy. Crimping tool features interchangeable steel dies. Ratchet action of tool controls crimping operation for precise uniform ferrule crimps.



Connector Type	Cable Type	Preferred Die Set	Crimp Dimensions
MCX SMA SMB SMC	RG-178/U RG-196/U	141-0000-901	Hex = .105 (2.67) Width = .325 (8.26)
MCX SMA SMB SMC 75 Ohm SMB	RG-161/U, RG-174/U RG-179/U, RG-187/U RG-188/U, RG-316/U LMR-100	141-0000-902	Hex = .128 (3.25) Width = .400 (10.16)
	RG-188/U, RG316/U RG-179/U, RG-187/U BELDEN 735A	141-0000-905	Hex = .151 (3.83) Width = .400 (10.16)
MCX SMA SMB	RG-58/U RG-141/U RG-303/U RG-55/U RG-142/U RG-223/U RG-400/U LMR-195 LMR-200	141-0000-903	Hex = .213 (5.41) Width = .375 (9.52)
SMA 75 Ohm SMB	LMR-240, RG-59	141-0000-925	Hex = .255 (6.48) Width = .400 (10.16)
N Type	RG-316/U, 316 DS	141-0000-927	Hex = .160 (4.06) Width = .400 (10.16)

\* Economy Hand Crimp Tool also available with four hex sizes in one tool page 187.

## Ordering Information for Crimp Tool

Part No.	Description	ASTRO Tool Part No.
144-0000-900	Frame Only	620175
141-0000-901	Single Hex Die	620932
141-0000-902	Single Hex Die	620419
141-0000-903	Single Hex Die	620676
141-0000-905	Single Hex Die	630055
141-0000-925	Single Hex Die	620938
141-0000-927	Single Hex Die	620297

## Ordering Information for Crimp Tool

Connector Type	Preferred Die Ste	Crimp Style
SMB Cross Hole Style Body 50 Ohm Only	141-0000-911	Double Diamond
Mini 75 Ohm SMB, MCX 75 Ohm Cross Hole Style Body	141-0000-924	Double Diamond

# Coaxial Connector Assembly Tools

## Economy Hand Crimp Tool

Hand crimp tool and die set includes all hex sizes necessary for subminiature connector applications. Ratchet tool action insures a complete crimp every time.



Part No.	Description	Hex	Width	Connector Type
140-0000-952	Hand Crimp Tool Frame Only			
140-0000-953	Die for .047" dia. flexible cable; RG-178, RG-316, RG-316 DS and Contact Crimp w/stop	.105 (2.67) .128 (3.25) .151 (3.83) Diamond Crimp for 038 (0.96) Dia. Contact	.250 (6.35) .250 (6.35) .250 (6.35) .035 (0.89)	MMCX*, MCX
140-0000-951	Die for RG-178, 316, 316 DS 58, 142, LMR-100, LMR-195, LMR-200A	.105 (2.67) .128 (3.25) .151 (3.83) .213 (5.41)	.390 (9.91) .390 (9.91) .390 (9.91) .390 (9.91)	MCX, SMB, SMC, SMA, 75 OHM SMB
140-0000-955	Die for RG-179, 179 DS, 735A, RG-59, LMR-240	.128 (3.25) .151 (3.83) .178 (4.52) .255 (6.48)	.390 (9.91) .390 (9.91) .390 (9.91) .390 (9.91)	75 Ohm MCX, SMA Mini-75 Ohm SMB

\* Use 140-0000-951 for MMCX straight cabled bulkhead jack body crimp.

## Economy Hand Crimp Tool

Hand crimp tool and die set includes all hex sizes necessary for subminiature connector applications. Ratchet tool action insures a complete crimp every time.



Part No.	Description	ASTRO Tool Part No.	Military Part No.
144-0000-910	Frame Only	615708	M22520/1-01
141-0000-907	Positioner	650027	N/A

## Economy Hand Crimp Tool

Hand crimp tool and die set includes all hex sizes necessary for subminiature connector applications. Ratchet tool action insures a complete crimp every time.



Part No.	Description	ASTRO Tool Part No.
140-0000-970	Frame Only	612118-1
140-0000-971	Positioner	N/A

## MMCX Assembly/Decoupling Tool

This tool will assemble the end cap to a standard right angle MMCX plug connector in the field. Simply insert connector and cap into tool cavity, then turn handle to swage the cap into place. The slotted end of the tool can be used to disengage a right angle MMCX plug from a mating receptacle.

Part No.
141-0000-910



For more information, please contact customer service at (507) 833-8822 or (800) 247-8256 • www.EmersonConnectivity.com

Illustrations are shown in inches (millimeters).

# Coaxial Connector Assembly Tools

## MCX Right Angle Plug Assembly Tool

This quick and easy to use tool will press the end cap onto standard right angle MCX plug connectors. Simply insert the connector and cap into the staking nest and a light squeeze of the handles will swage the cap into place. The jaw tips are shaped to grip a right angle MCX plug body for insertion or disengagement to a mating receptacle. The jaws are hardened steel and the handles are cushioned to minimize stress to the user. For use with all cable groups except RG-58.



Part No.
141-0000-908

## SMA Knurl Mount Assembly Tool

The Knurl Mount SMA Spark Plug Connectors can be pressed into position using this thread-on fixture designed for low volume lab use.



Part No.
140-0000-954

## SMB Plug Removal Tool

Reaches in to disengage SMB connectors in high density packaging applications.



Part No.
140-0000-956

# Coaxial Connector Assembly Tools

## SMK (2.92mm) Tools

Accurate assembly of the SMK cabled connectors is obtained with the tools listed below. Industry standard devices are used if possible for customer convenience and tool compatibility.



Item	Part No.	Description
A	140-0000-962	Semi-Rigid Cable Vise (does not include inserts (B) or Vise Stop (F))
B	140-0000-964	Cable Clamp Inserts, .086 Semi-Rigid
	140-0000-965	Cable Clamp Inserts, .141 Semi-Rigid
C	140-0000-960	Contact Soldering Tool, .086 Plug
	140-0000-961	Contact Soldering Tool, .141 Plug
D	140-0000-958	Body Soldering Tool, .086 Plug
	140-0000-959	Body Soldering Tool, .141 Plug
E	140-0000-957	Bead Assembly Tool, Semi-Rigid Plugs, All Cables
F	140-0000-968	Vise Stop, (2.92mm)

# We Have What You Are Looking For ... and If We Don't, We'll Design and Manufacture It!!!

Emerson Network Power Connectivity Solutions prides itself in meeting our customers' needs by providing them with customized solutions. We have configured our technical staff and equipped our model shop and QA lab to meet the quick-turn demands of new product development. Prototypes, samples, and short-run quantities are delivered expediently and to print. Your new product development life cycle will be greatly enhanced with us as a partner on your design team.



We have an extensive log of special variations of MMCX, MCX, 75 Ohm MCX, SMK, SMA, SMP, SMB, Mini-75 Ohm SMB, SMC, BNC, TNC and N connectors. Special cable sizes, cable assemblies, PC board terminations, adapters, antenna connectors, multi-packs, calibration terminations and hardware products give us a large pool of design experience to assist you with custom development. See page 259 for more information on our custom hardware products.

Our sales representatives will review your product application and initiate the quotation process, and our sales and engineering staff will assist you in defining the performance and cost parameters required by your end product. Providing details such as dimensional limitations, frequency, and VSWR performance to our field sales representative will speed the process.

After you have chosen us as your supplier, we can provide samples and a short run quantity prior to production of your custom product. We look forward to providing your special electronic components in the future.



**We do it all...**  
**Virtually any RF coaxial connector or RF cable assembly from the engineering, prototyping and tooling stages, to complete production and testing.**



N Jack 75 Ohm to MCX Plug  
75 Ohm Assembly, Adapter



Ganged MCX Right-Angle  
Board Mount



SMB Vertical  
PC Plug

# Custom Engineered RF Coaxial Cable Assemblies

With over 75 years of experience, Emerson Network Power Connectivity Solutions is your interconnect solution for cable assembly design, high quality production and on-time delivery. Our Johnson line of precision cable assemblies includes standard RF coaxial cable assemblies such as flexible, conformable and semi-rigid types for 50 or 75 ohm systems from 0 to 40 GHz. We can work with almost any connector, including our complete line of Johnson connectors including SMK, SMP, SMA, SMB, SMC, BNC, TNC, N, F, UHF, Mini-UHF, MCX and MMCX connectors. Cable assemblies manufactured with our RF connectors assure you controlled impedance throughout the cable length. Our skilled personnel adhere to rigorous quality assurance procedures, giving you the cables you need, on time, without hassles.



Backed by test data shipped with the product! Our assemblies are delivered completely tested to customer specifications and carry our complete customer satisfaction guarantee. By having us make your cable assemblies, you save the cost of training personnel; discarding damaged parts; cable testing; and replacing faulty inventory. You save on overhead, manufacturing and equipment costs and you receive proven cost effective cable assemblies on time and to your specifications. We are an industry leader in the RF coaxial connector and electronic hardware market...you can rely on Emerson Network Power Connectivity Solutions for all your assembly needs.



**We're responsive, reliable and ready to work with you.**



2x3 Position SMA Straight Plug  
to MCX Straight Plug



For more information, please contact customer service at (507) 833-8822 or (800) 247-8256 • [www.EmersonConnectivity.com](http://www.EmersonConnectivity.com)

Illustrations are shown in inches (millimeters).



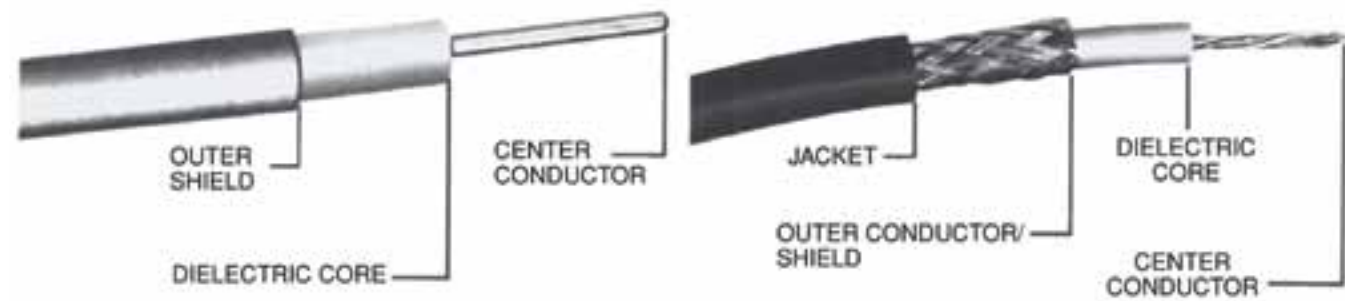

Semi-Rigid Cable Dimensions

Cable	Center Conductor O.D.	O.D. Dielectric	O.D. Shield	Impedance
RG-405/U	.0201 (0.51)	.0658 (1.67)	.086 (2.18)	50
RG-402/U	.0359 (0.91)	.1175 (2.98)	.141 (3.58)	50

RF Flexible Cable Dimension

Cable	Center Conductor	O.D. Dielectric	O.D. Shield	O.D. Jacket	Impedance
.047 dia.	.007 (0.19)	.020 (0.52)	.035 (0.90)	.047 (1.20)	50
RG-178B/U	.012 (.030)	.034 (0.86)	.054 (1.37)	.071 (1.80)	50
RG-196A/U	.012 (.030)	.034 (0.86)	.054 (1.37)	.071 (1.80)	50
RG-174/U	.019 (0.48)	.060 (1.52)	.080 (2.03)	.110 (2.79)	50
RG-179B/U	.012 (.030)	.063 (1.60)	.084 (2.13)	.110 (2.79)	75
RG-187A/U	.012 (.030)	.060 (1.52)	.084 (2.13)	.110 (2.79)	75
RG-188A/U	.020 (0.51)	.060 (1.52)	.081 (2.06)	.110 (2.79)	50
RG-316/U	.020 (0.51)	.060 (1.52)	.081 (2.06)	.110 (2.79)	50
RG-316 DS	.020 (0.51)	.060 (1.52)	(DS) .100 (2.54)	.120 (3.05)	50
RG-179 DS	.012 (.030)	.063 (1.60)	(DS) .103 (2.62)	.120 (3.05)	75
RG-187 DS	.012 (.030)	.060 (1.52)	(DS) .100 (2.54)	.120 (3.05)	75
RG-188 DS	.020 (0.51)	.060 (1.52)	(DS) .100 (2.54)	.120 (3.05)	50
RG-141A/U	.039 (0.99)	.116 (2.95)	.146 (3.71)	.190 (4.83)	50
RG-303/U	.039 (0.96)	.116 (2.95)	.146 (3.71)	.190 (4.83)	50
RG-400/U	.038 (0.96)	.116 (2.95)	(DS) .171 (4.34)	.195 (4.85)	50
RG-142B/U	.039 (0.99)	.116 (2.95)	(DS) .171 (4.34)	.195 (4.95)	50
RG-58C/U	.038 (0.96)	.116 (2.95)	.150 (3.81)	.195 (4.95)	50
RG-55B/U	.032 (0.81)	.116 (2.95)	(DS) .176 (4.47)	.206 (5.23)	53.5
RG-223/U	.032 (0.81)	.116 (2.95)	(DS) .176 (4.47)	.206 (5.23)	53.5
LMR-100	.022 (.056)	.062 (1.57)	.085 (2.16)	.105 (2.67)	50
LMR-195	.037 (0.94)	.110 (2.79)	.139 (3.53)	.195 (4.95)	50
LMR-200	.044 (1.12)	.116 (2.95)	.144 (3.66)	.195 (4.95)	50
LMR-240	.056 (1.42)	.150 (3.81)	.178 (4.52)	.240 (6.10)	50
735A	.016 (0.41)	.077 (1.96)	.101 (2.57)	.128 (3.25)	75
RG-59	.0226 (0.57)	.146 (3.71)	.191 (4.85)	.242 (6.15)	75

Assembly Instructions

Other Information  
 Assembly Tools ..... 185  
 Capabilities ..... 190  
 Cable Information ..... 192  
 Assembly Instruction ..... 193  
 Mounting Hole Layouts ..... 194  
 Numerical Index ..... 274  
 Competitor Cross Reference ..... 280

3 **MMCX Connectors**

13 **MCX Connectors**

39 **SMK Connectors**

45 **SMA Connectors**

103 **SMB Connectors**

131 **SMC Connectors**

137 **SMP Connectors**

145 **Type N Connectors**

153 **Shielded Cable Terminations**

157 **Between-Series Adapters**

161 **Fixed Length Cable Assemblies**

173 **Ultra Miniature Connectors (UMC)**

181 **kwiQMate™ Connectors**

185 **Tools**

193 **Assembly Instructions**

257 **Electronic Hardware**

274 **Index**

While every precaution has been taken to ensure accuracy and completeness herein, Emerson Network Power Connectivity Solutions assumes no responsibility, and disclaims all liability for damages resulting from use of this information or for any errors or omissions. Specifications subject to change without notice.

# Recommended Mounting Hole Dimensions

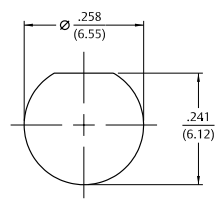

1

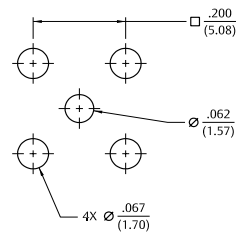

2

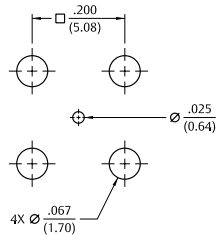

3

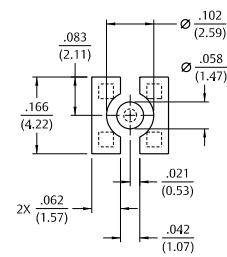

13

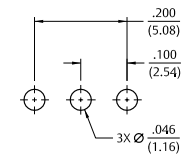

14

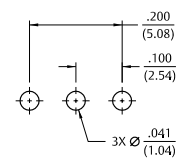

15

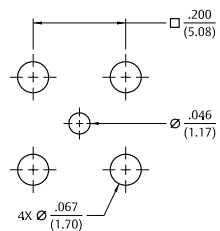

4

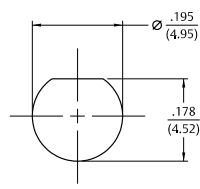

5

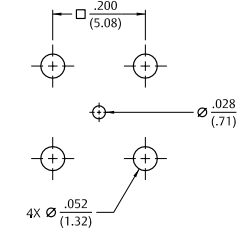

6

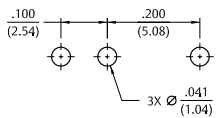

16

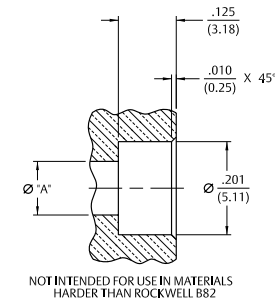

17

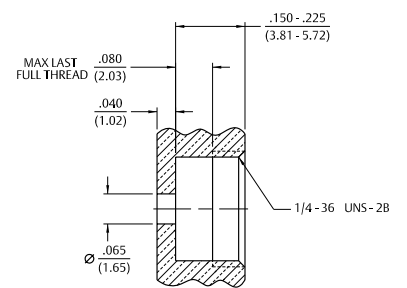

18

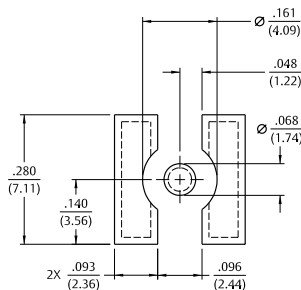

7

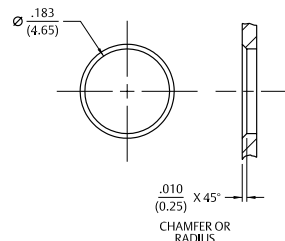

8

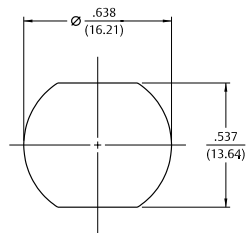

9

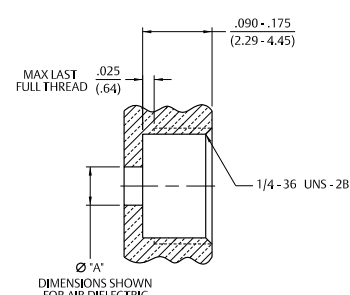

19

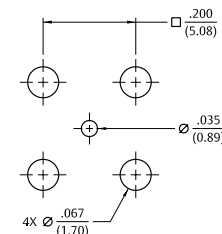

20

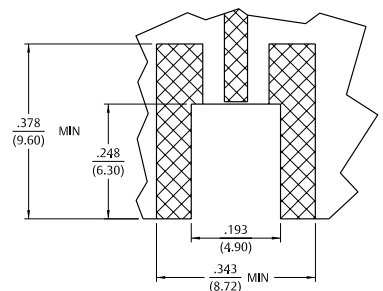

21

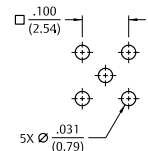

10

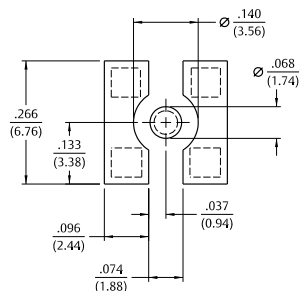

11

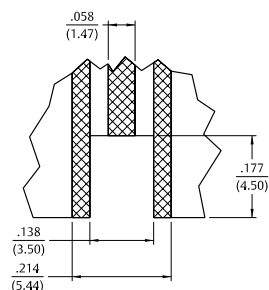

12

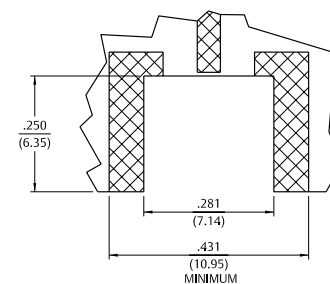

22

# Recommended Mounting Hole Dimensions

131-1402-101.....	238	131-6404-006.....	237	133-3403-101.....	210	135-3436-001.....	202
131-1402-116.....	238	131-6404-101.....	238	133-3403-106.....	210	135-3436-101.....	200
131-1403-001.....	237	131-6404-106.....	238	133-3404-001.....	207	135-3693-101.....	198
131-1403-016.....	237	131-6433-001.....	237	133-3404-006.....	207	135-9402-001.....	205
131-1403-101.....	238	131-6433-006.....	237	133-3404-101.....	210	135-9402-111.....	199
131-1403-116.....	238	131-6433-101.....	238	133-3404-106.....	210	135-9403-001.....	204
131-1404-001.....	237	131-6433-106.....	238	133-3407-101.....	210	135-9403-101.....	199
131-1404-016.....	237	131-6593-401.....	233	133-3407-106.....	210	135-9404-001.....	204
131-1404-101.....	238	131-6593-406.....	233	133-3433-001.....	207	135-9436-001.....	205
131-1404-116.....	238	131-8303-401.....	237	133-3433-006.....	207	135-9436-101.....	200
131-1693-101.....	234	131-8303-406.....	237	133-3433-101.....	210	138-4303-407.....	248
131-1693-116.....	234	131-8304-401.....	237	133-3433-106.....	210	138-4304-407.....	248
131-3302-001.....	237	131-8304-406.....	237	133-3693-001.....	206	138-4307-407.....	251
131-3302-006.....	237	131-8403-001.....	237	133-3693-006.....	206	138-4308-407.....	251
131-3303-001.....	237	131-8403-006.....	237	133-3693-101.....	206	138-4316-407.....	251
131-3303-006.....	237	131-8403-011.....	237	133-3693-106.....	206	138-4318-407.....	251
131-3303-401.....	237	131-8403-016.....	237	133-5302-401.....	207	138-4349-407.....	251
131-3303-406.....	237	131-8403-101.....	238	133-5302-406.....	207	138-4403-007.....	242
131-3303-501.....	238	131-8403-106.....	238	133-5303-401.....	207	138-4403-107.....	244
131-3303-506.....	238	131-8403-111.....	238	133-5303-406.....	207	138-4404-007.....	242
131-3304-401.....	237	131-8403-116.....	238	133-5304-401.....	207	138-4404-107.....	244
131-3304-406.....	237	131-8404-001.....	237	133-5304-406.....	207	138-4407-007.....	243
131-3304-501.....	238	131-8404-006.....	237	133-5402-001.....	207	138-4407-107.....	244
131-3304-506.....	238	131-8404-011.....	237	133-5402-006.....	207	138-4408-007.....	243
131-3402-001.....	237	131-8404-016.....	237	133-5402-101.....	210	138-4408-107.....	244
131-3402-016.....	237	131-8404-101.....	238	133-5402-106.....	210	138-4416-007.....	243
131-3402-101.....	238	131-8404-106.....	238	133-5403-001.....	207	138-4416-107.....	245
131-3402-116.....	238	131-8404-111.....	238	133-5403-006.....	207	138-4418-007.....	243
131-3403-001.....	237	131-8404-116.....	238	133-5403-101.....	210	138-4418-107.....	245
131-3403-016.....	237	131-8409-001.....	237	133-5403-106.....	210	138-4449-007.....	243
131-3403-021.....	232	131-8409-006.....	237	133-5404-001.....	207	138-4593-401.....	250
131-3403-026.....	232	131-8409-101.....	238	133-5404-006.....	207	138-4594-401.....	250
131-3403-101.....	238	131-8409-106.....	238	133-5404-101.....	210	138-4596-401.....	250
131-3403-116.....	238	131-8433-001.....	232	133-5404-106.....	210	138-4693-001.....	246
131-3403-401.....	237	131-8433-006.....	232	133-8333-001.....	209	138-4693-011.....	247
131-3403-406.....	237	131-8434-001.....	232	133-8333-401.....	209	138-4694-001.....	246
131-3404-001.....	237	131-8434-006.....	232	133-8334-001.....	209	138-4694-011.....	247
131-3404-016.....	237	131-8445-001.....	237	133-8334-401.....	209	138-4696-001.....	246
131-3404-021.....	232	131-8445-006.....	237	133-8433-001.....	209	138-4696-011.....	247
131-3404-026.....	232	131-8445-011.....	232	133-8433-101.....	211	138-9408-007.....	240
131-3404-101.....	238	131-8445-016.....	232	133-8434-001.....	209	138-9449-007.....	240
131-3404-116.....	238	131-8445-101.....	238	133-8434-101.....	211	141-0303-412.....	219
131-3404-401.....	237	131-8445-106.....	238	133-8445-001.....	209	141-0304-412.....	219
131-3404-406.....	237	131-9403-001.....	235	133-8445-101.....	211	141-0307-412.....	219
131-3407-001.....	237	131-9403-021.....	232	133-9402-101.....	208	141-0308-412.....	219
131-3407-006.....	237	131-9403-101.....	236	133-9402-101.....	208	141-0403-012.....	219
131-3407-011.....	232	131-9403-116.....	236	133-9403-001.....	207	141-0403-102.....	224
131-3407-016.....	232	131-9404-001.....	235	133-9403-101.....	208	141-0403-104.....	219
131-3407-101.....	238	131-9404-021.....	232	133-9403-104.....	208	141-0404-012.....	219
131-3407-106.....	238	131-9404-101.....	236	133-9404-001.....	207	141-0404-112.....	224
131-3593-401.....	233	131-9404-116.....	236	133-9404-101.....	208	141-0407-012.....	219
131-3593-406.....	233	133-3302-001.....	207	134-0303-406.....	239	141-0407-102.....	224
131-3693-001.....	233	133-3302-006.....	207	134-0304-406.....	239	141-0408-012.....	219
131-3693-016.....	233	133-3302-401.....	207	134-0304-406.....	239	141-0408-102.....	224
131-3693-101.....	234	133-3302-406.....	207	135-3302-001.....	205	141-0593-001.....	214
131-3693-116.....	234	133-3303-001.....	207	135-3302-401.....	205	141-0593-401.....	214
131-3694-401.....	233	133-3303-006.....	207	135-3303-001.....	204	141-0593-421.....	222
131-3694-406.....	233	133-3303-401.....	207	135-3304-001.....	204	141-0594-001.....	214
131-6303-401.....	237	133-3303-406.....	207	135-3333-001.....	204	141-0594-421.....	222
131-6303-406.....	237	133-3304-001.....	207	135-3336-001.....	205	141-0693-002.....	214
131-6304-401.....	237	133-3304-006.....	207	135-3336-401.....	205	141-0693-062.....	222
131-6304-406.....	237	133-3304-401.....	207	135-3402-001.....	202	141-0694-002.....	214
131-6333-401.....	237	133-3304-406.....	207	135-3402-001.....	202	141-0694-012.....	214
131-6333-406.....	237	133-3402-001.....	207	135-3402-111.....	201	141-0694-062.....	222
131-6403-001.....	237	133-3402-006.....	207	135-3403-001.....	203	141-0694-062.....	222
131-6403-006.....	237	133-3402-101.....	210	135-3403-101.....	201	142-0002-221.....	252
131-6403-101.....	238	133-3402-106.....	210	135-3403-101.....	201	142-0002-226.....	252
131-6403-106.....	238	133-3403-001.....	207	135-3404-001.....	203	142-0002-811.....	253
131-6404-001.....	237	133-3403-006.....	207	135-3404-101.....	201	142-0002-821.....	254
				135-3433-001.....	203	142-0003-201.....	252

142-0003-206.....	252	142-0307-016.....	219	142-0693-051.....	216	142-4408-101.....	224
142-0003-231.....	252	142-0307-401.....	225	142-0693-056.....	216	142-4408-106.....	224
142-0003-236.....	252	142-0307-406.....	225	142-0693-101.....	213	142-4435-001.....	220
142-0003-241.....	252	142-0307-411.....	219	142-0693-106.....	213	142-4435-006.....	220
142-0003-246.....	252	142-0307-416.....	219	142-0694-001.....	214	142-4435-101.....	229
142-0003-301.....	252	142-0308-011.....	219	142-0694-006.....	214	142-4435-106.....	229
142-0003-306.....	252	142-0308-016.....	219	142-0694-011.....	214	142-4439-001.....	220
142-0003-801.....	253	142-0308-401.....	225	142-0694-016.....	214	142-4439-006.....	220
142-0003-811.....	253	142-0308-406.....	225	142-0694-021.....	215	142-4439-101.....	229
142-0004-201.....	252	142-0308-411.....	219	142-0694-026.....	215	142-4439-106.....	229
142-0004-206.....	252	142-0308-416.....	219	142-0694-031.....	215	142-5303-401.....	219
142-0004-211.....	252	142-0333-011.....	219	142-0694-036.....	215	142-5303-406.....	219
142-0004-216.....	252	142-0333-016.....	219	142-0694-041.....	215	142-5304-401.....	219
142-0004-221.....	252	142-0333-411.....	219	142-0694-046.....	215	142-5304-406.....	219
142-0004-226.....	252	142-0333-416.....	219	142-0694-051.....	216	142-5307-401.....	219
142-0004-301.....	252	142-0335-401.....	220	142-0694-056.....	216	142-5307-406.....	219
142-0004-306.....	252	142-0335-406.....	220	142-0694-101.....	213	142-5308-401.....	219
142-0004-801.....	253	142-0339-401.....	220	142-0694-106.....	213	142-5308-406.....	219
142-0004-811.....	253	142-0339-406.....	220	142-0694-106.....	213	142-5308-406.....	219
142-0007-801.....	253	142-0761-801.....	228	142-0761-801.....	228	142-5403-001.....	219
142-0007-811.....	253	142-0402-011.....	217	142-0761-811.....	228	142-5403-006.....	219
142-0008-801.....	253	142-0402-016.....	217	142-0761-821.....	228	142-5403-101.....	224
142-0008-811.....	253	142-0402-101.....	224	142-0761-821.....	228	142-5403-106.....	224
142-0093-806.....	253	142-0402-106.....	224	142-0761-841.....	228	142-5404-001.....	219
142-0094-801.....	253	142-0403-001.....	225	142-0761-851.....	228	142-5404-006.....	219
142-0094-806.....	253	142-0403-006.....	225	142-0761-861.....	228	142-5404-101.....	224
142-0096-801.....	253	142-0403-011.....	219	142-0761-871.....	228	142-5404-106.....	224
142-0096-806.....	253	142-0403-016.....	219	142-0761-881.....	228	142-5407-001.....	219
142-0102-401.....	230	142-0403-101.....	224	142-0761-891.....	228	142-5407-006.....	219
142-0102-406.....	230	142-0403-106.....	224	142-0761-891.....	228	142-5407-101.....	224
142-0103-401.....	230	142-0404-011.....	219	142-0771-821.....	228	142-5407-106.....	224
142-0103-406.....	230	142-0404-016.....	219	142-0771-831.....	228	142-5407-106.....	224
142-0107-401.....	230	142-0404-101.....	224	142-0791-801.....	227	142-5408-001.....	219
142-0107-406.....	230	142-0404-106.....	224	142-0791-811.....	227	142-5408-006.....	219
142-0202-011.....	230	142-0407-011.....	219	142-0791-821.....	227	142-5408-101.....	224
142-0202-016.....	230	142-0407-016.....	219	142-0791-821.....	227	142-5408-106.....	224
142-0202-101.....	231	142-0407-101.....	224	142-0801-421.....	216	142-5435-001.....	220
142-0202-106.....	231	142-0407-106.....	224	142-1403-001.....	219	142-5435-006.....	220
142-0203-011.....	230	142-0408-011.....	219	142-1403-006.....	219	142-5435-101.....	229
142-0203-016.....	230	142-0408-016.....	219	142-1404-001.....	219	142-5435-106.....	229
142-0203-101.....	231	142-0408-101.....	224	142-1404-006.....	219	142-5439-001.....	220
142-0203-106.....	231	142-0408-106.....					

### MMCX Right Angle Plug for .086 (2.18) Semi-Rigid Cable

1. Identify piece parts. (2 piece parts)
2. Strip cable to dimensions shown. Do not nick center conductor.
3. Insert cable into body making certain that jacket bottoms on the connector body. Fixture cable and assembly to prevent movement during soldering.
4. Solder center conductor to contact as shown. Use a minimum amount of solder for a good joint.
5. Solder body to cable as shown. Use a minimum amount of heat to minimize cable insulation movement.
6. Press end cap into body access port using .156 (3.96) diameter flat punch or Johnson assembly tool 141-0000-910.

Cable Group	Part No.
RG-405/U (.086 Semi-Rigid)	135-3693-101

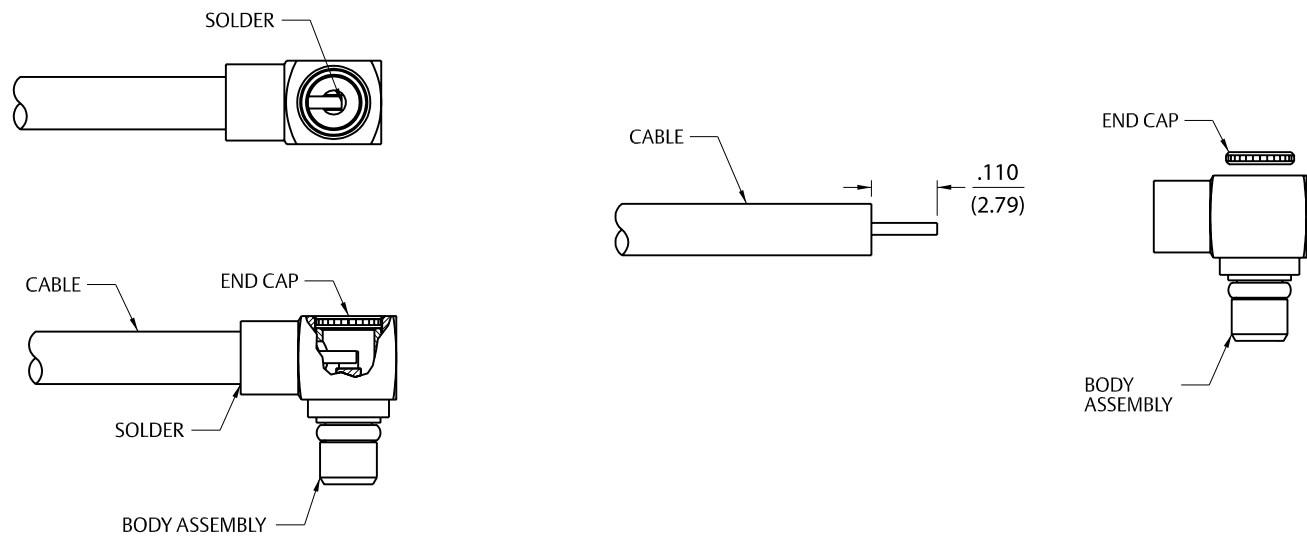

### MMCX Right Angle Plug for RG-178 and RG-316 Size Flexible Cable

1. Identify piece parts. (3 piece parts)
2. Strip cable jacket to dimensions shown. Do not nick braid or center conductor during strip operations. Tin center conductor. Slide crimp sleeve onto cable jacket.
3. Flair braid and assemble crimp stem of body subassembly under braid onto cable making certain that the cable center conductor enters contact slot as shown. Arrange braid uniformly around crimp stem. Slide crimp sleeve over braid and crimp securely using recommended crimp hex.
4. Solder center conductor to contact through rear access port. Use a minimum amount of solder for a full fillet joint.
5. Press end cap into body access port using .156 (3.96) diameter flat punch or Johnson assembly tool 141-0000-91.

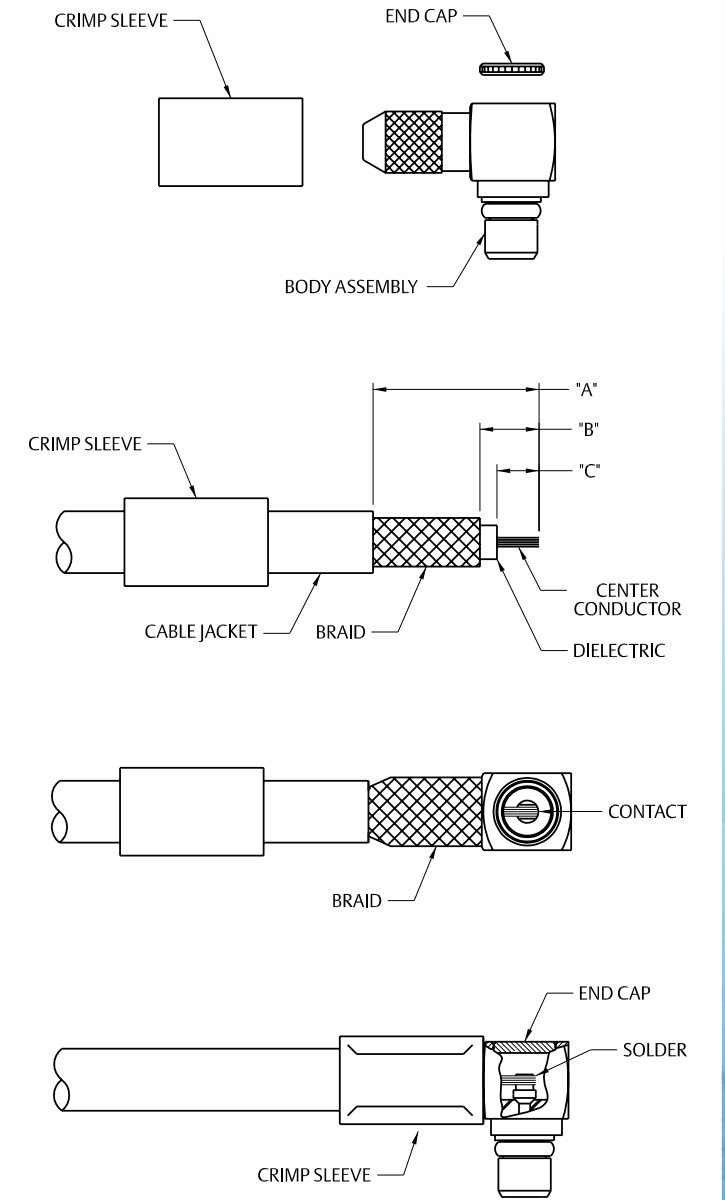

Cable Group	Part No.	Sleeve Hex	"A"	"B"	"C"
RG-178, 196	135-9402-111	.105 (2.67)	.310	.100	.035
RG-316/U, 188, 187, 179	135-9403-101	.128 (3.25)	.295	.105	.075

### MMCX Right Angle Plug for .047 (1.20) Diameter and RG-178 Size Flexible Cable with Crimp Insert

1. Identify piece parts. (3 piece parts)
2. Strip cable jacket to dimensions shown. Do not nick braid or center conductor during strip operations. Tin center conductor. Slide crimp sleeve onto cable jacket.
3. Slide crimp insert over braid and against jacket. Fold braid around crimp insert as shown. Strip cable dielectric to dimension shown. Tin center conductor.
4. Slide body assembly over cable and crimp insert, then seat firmly so cable dielectric butts against contact as shown. Crimp body using recommended crimp hex. Maintain forward pressure on cable while crimping.
5. Solder contact to center conductor through rear access port. Use a minimum amount of solder for a full fillet joint.
6. Press end cap into access port using .156 (3.96) diameter flat punch or Johnson assembly tool 141-0000-910.

Cable Group	Part No.	"L"	Crimp Hex
.047 Flexible	135-3436-101	.140 (3.56)	.105 (2.67)
RG-178/U, 196	135-3402-101	.188 (4.78)	.105 (2.67)
.047 Flexible	135-9436-101	.140 (3.56)	.105 (2.67)

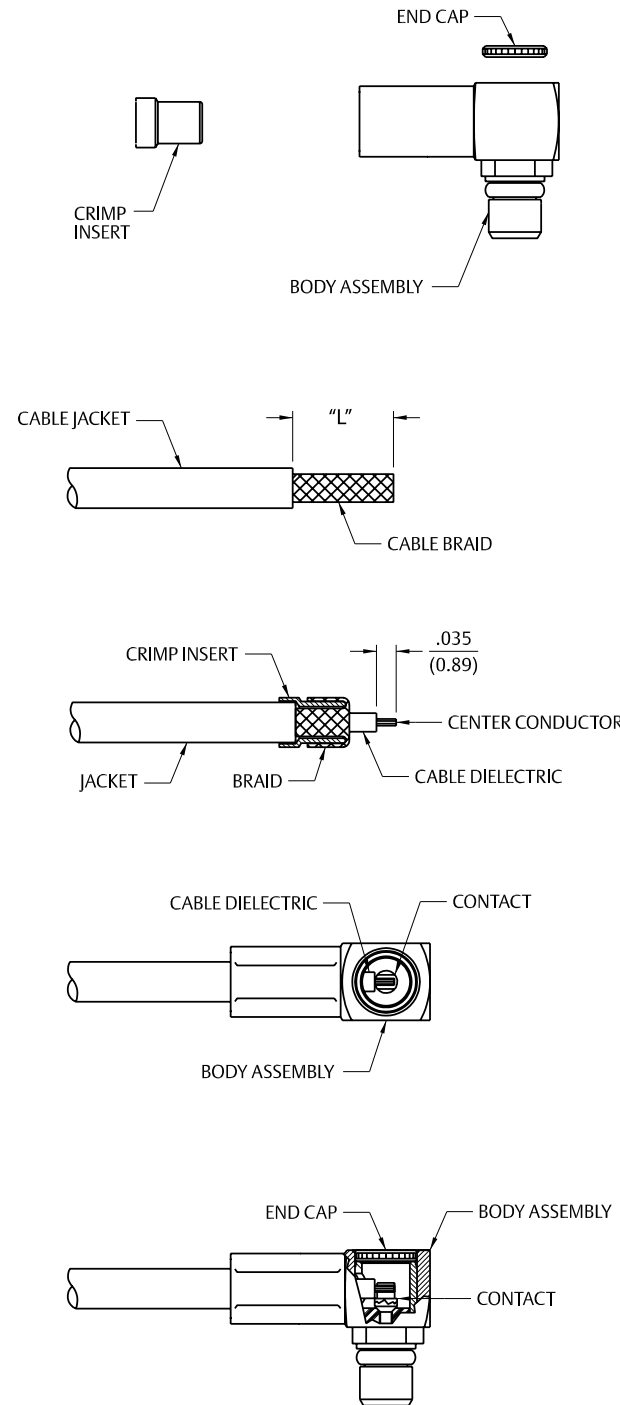

### MMCX Right Angle Plug for RG-178, RG-316, RG-316 DS and RG-179 Size Flexible Cable

1. Identify connector parts. (3 piece parts)
2. Strip cable jacket to dimensions shown. Do not nick braid or center conductor during strip operations. Tin center conductor. Slide crimp sleeve onto cable jacket.
3. Flair braid and assemble crimp stem of body subassembly under braid onto cable making certain that the cable center conductor enters contact slot as shown. Arrange braid uniformly around crimp stem. Slide crimp sleeve over braid and crimp securely using recommended crimp hex.
4. Solder center conductor to contact through rear access port. Use a minimum amount of solder for a full fillet joint.
5. Press end cap into body access port using .156 (3.96) diameter flat punch or Johnson assembly tool 141-000-910.

Cable Group	Part No.	Crimp Hex	"A"	"B"	"C"
RG-178, 196	135-3402-111	.105 (2.67)	.310	.100	.035
RG-316/U, 188, 187, 179	135-3403-101	.128 (3.25)	.295	.105	.075
RG-316 DS, 188 DS	135-3404-101	.151 (3.83)	.295	.105	.075

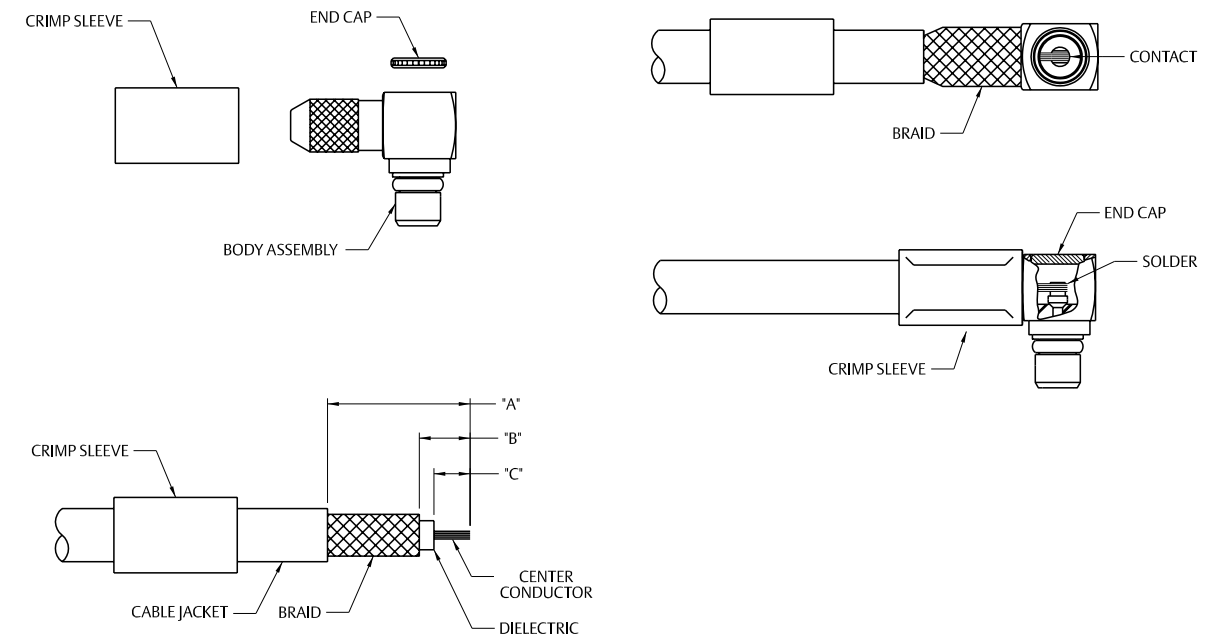

### MMCX Straight Plug for .047 (1.19) Diameter and RG-178 Size Flexible Cable

1. Identify piece parts. (3 piece parts)
2. Strip cable jacket to dimensions shown. Do not nick braid or center conductor during strip operations.
3. Slide crimp insert over braid and against jacket. Fold braid around crimp insert as shown. Strip dielectric to dimension shown. Tin center conductor if contact is to be soldered attached. Do not tin center conductor if contact is to be crimp attached.
4. Assemble contact assembly onto cable as shown.  
**Solder attachment:** Solder contact to center conductor. Care should be taken that excess solder is not applied.  
**Crimp attachment:** Crimp contact to center conductor using Johnson hand tool 140-0000-952 and die set 140-0000-953. Crimp location should be centered between end of contact and cross-hole. Crimp attachment to solid center conductor cables is not recommended.
5. Slide body assembly over contact and crimp insert, then seat firmly as shown. Crimp body using recommended crimp die hex. Maintain forward pressure on cable while crimping.

Cable Group	Part No.	Strip Length	Crimp Hex
.047 Flexible	135-3436-001	.135 (3.43)	.105 (2.67) x .250 (6.35) W
RG-178/U, 196	135-3402-001	.184 (4.67)	.105 (2.67) x .250 (6.35) W

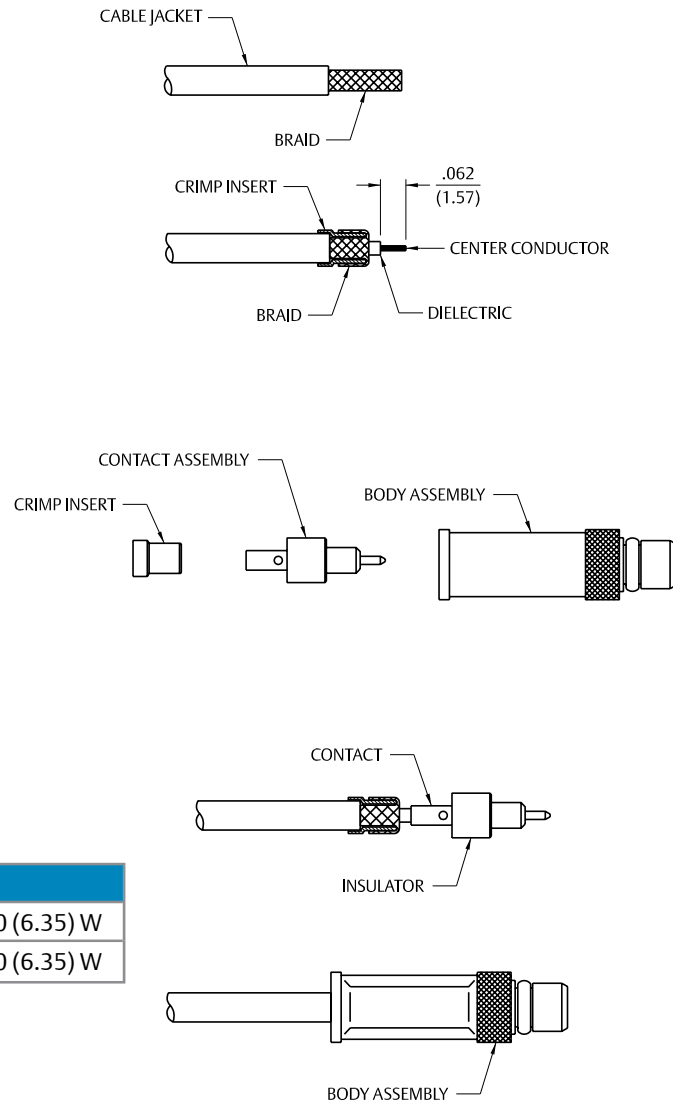

### MMCX Straight Plug for RG-316, RG-179 and RG-316 DS Size Flexible Cable

1. Identify connector parts. (3 piece parts)
2. Strip cable jacket to dimensions shown. Do not nick braid or center conductor during strip operations. Tin center conductor if contact will be solder attached. Do not tin center conductor if contact is to be crimp attached. Slide crimp sleeve onto cable jacket.
3. Assemble contact onto cable as shown.  
**Solder attachment:** Solder contact to center conductor. Care should be taken that excess solder is not applied.  
**Crimp attachment:** Crimp contact to center conductor using Johnson hand tool 140-0000-952 and die set 140-0000-953. Crimp location should be centered between end of contact and cross-hole. Crimp attachment to solid center conductor cables is not recommended.
4. Slide body assembly over contact and under braid, then seat firmly onto contact as shown. The body assembly will “snap” over the contact barb. The cable may have to be held in a soft jawed clamping fixture. Slide crimp sleeve forward and crimp using recommended crimp die hex.

Cable Group	Part No.	Crimp Hex
RG-316/U, 188, 161, 174	135-3403-001	.128 (3.25)
RG-316 DS, 188 DS, 187 DS	135-3404-001	.151 (3.83)
RG-179/U, 187	135-3433-001	.128 (3.25)

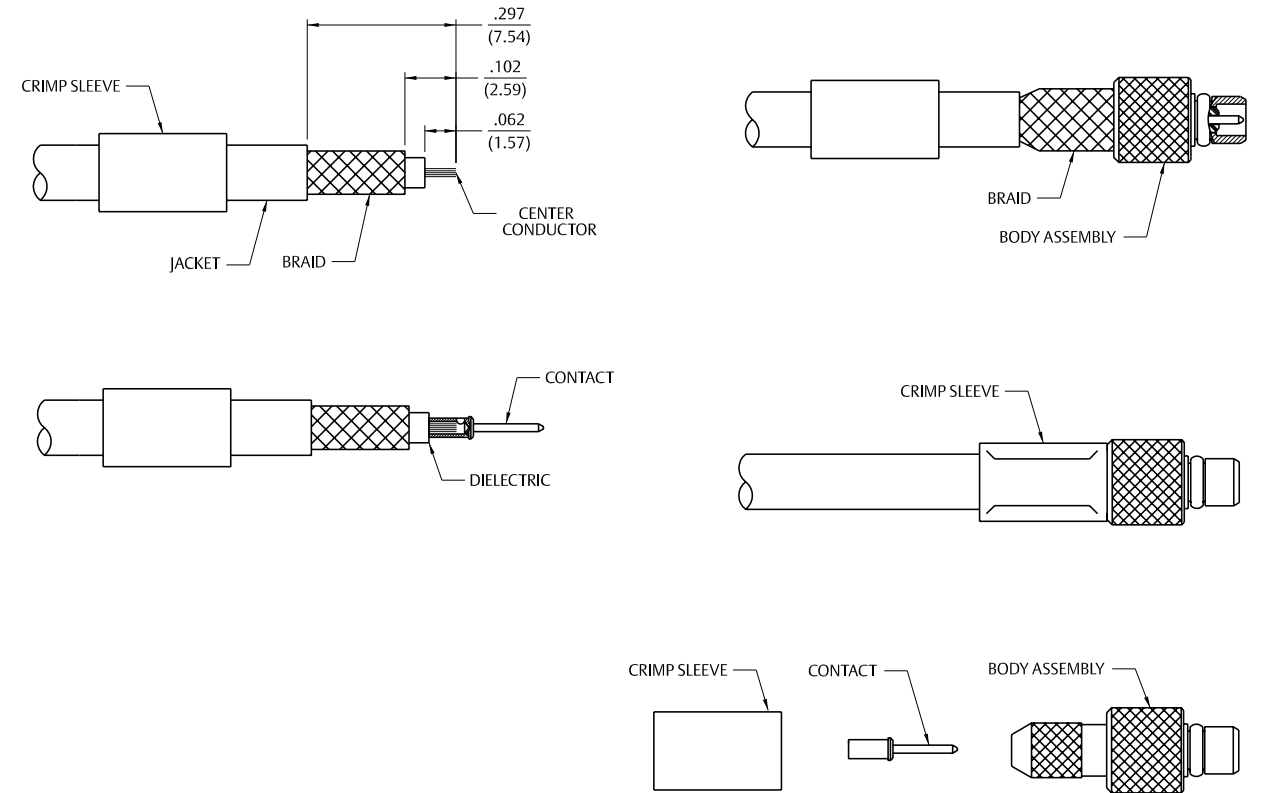

### MMCX Straight Jack for RG-316, RG-316 DS and RG-179 Size Flexible Cable

1. Identify connector parts. (3 piece parts)
2. Strip cable jacket to dimensions shown. Do not nick braid or center conductor during strip operations. Tin center conductor if contact will be solder attached. Do not tin center conductor if contact is to be crimp attached. Slide crimp sleeve onto cable jacket.
3. Assemble contact onto cable.
 

**Solder attachment:** Solder contact to center conductor. Care should be taken that excess solder is not applied.

**Crimp attachment:** Crimp contact to center conductor using Johnson hand tool 140-0000-952 and die set 140-0000-953. Crimp location should be centered between end of contact and cross-hole. Crimp attachment to solid center conductor cables is not recommended.
4. Slide body assembly over contact and under braid, then seat firmly onto contact. The body assembly will “snap” over the contact barb. The cable may have to be held in a soft jawed clamping fixture. Slide crimp sleeve forward and crimp using recommended crimp die hex.

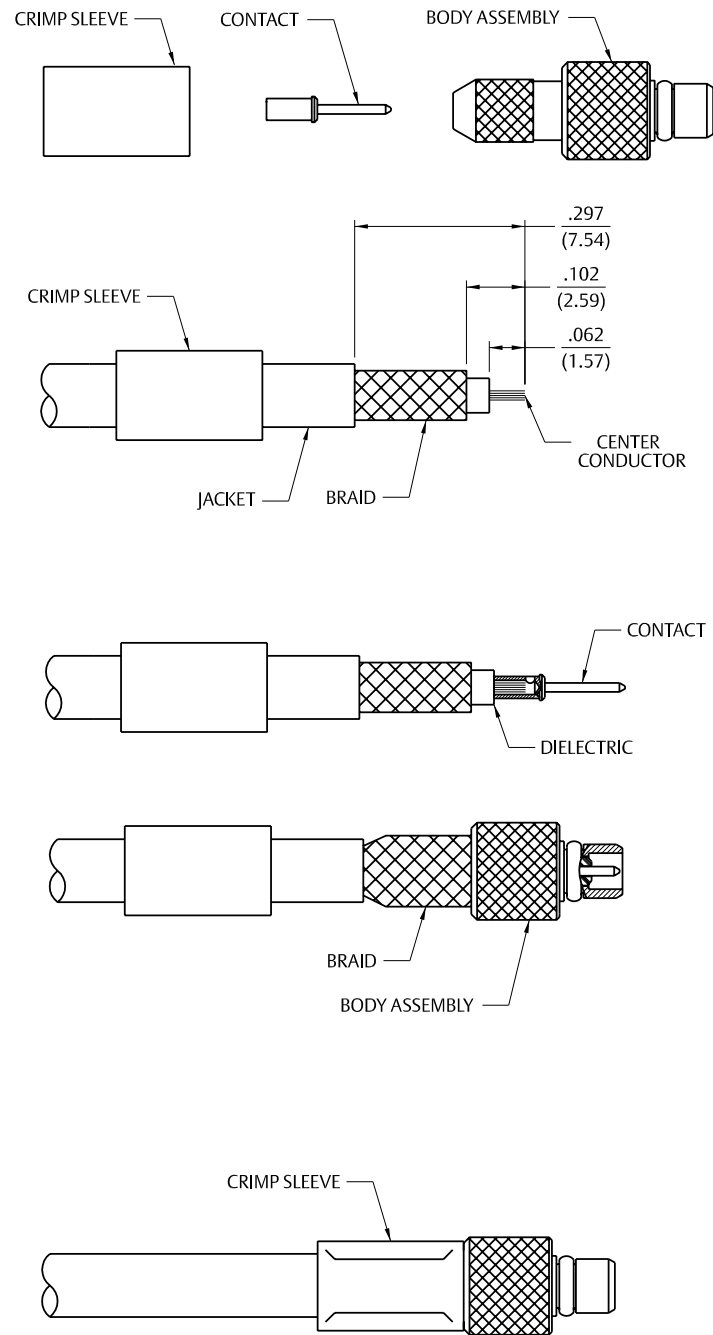

Cable Group	Part No.	Crimp Hex
RG-316/U, 188, 161, 174	135-3303-001	.128 (3.25)
RG-316 DS, 188 DS, 187 DS	135-3304-001	.151 (3.83)
RG-179/U, 187	135-3333-001	.128 (3.25)
RG-316/u, 188, 174	135-9403-001	.128 (3.25)
RG-316 DS, 188 DS	135-9404-001	.151 (3.83)

### MMCX Straight Jack for .047 Diameter and RG-178 Size Flexible Cable

1. Identify connector parts. (3 piece parts – except bulkhead jack as shown.)
2. Strip cable jacket to dimensions shown. Do not nick braid or center conductor during strip operations.
3. Slide crimp insert over braid and against jacket, fold braid around crimp insert. Strip dielectric to dimension shown. Tin center conductor if contact will be solder attached. Do not tin center conductor if contact is to be crimp attached.
4. Assemble contact assembly onto cable as shown.
 

**Solder attachment:** Solder contact to center conductor. Care should be taken that excess solder is not applied.

**Crimp attachment:** Crimp contact to center conductor using Johnson hand tool 140-0000-952 and die set 140-0000-953. Crimp location should be centered between end of contact and cross-hole. Crimp attachment to solid center conductor cables is not recommended.
5. Slide body assembly over contact and crimp insert, then seat firmly onto contact. Crimp body using recommended crimp hex. Bulkhead jack requires 140-000-951 dieset. Maintain forward pressure on cable while crimping.

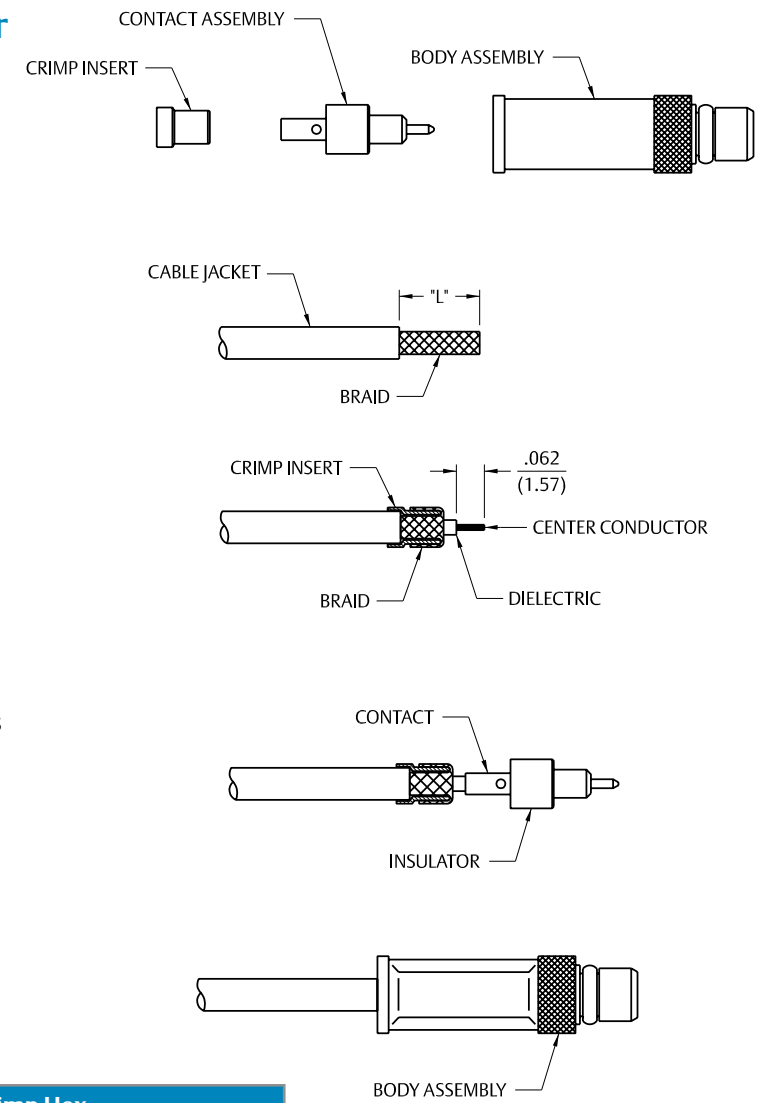

Cable Group	Part No.	“L”	Crimp Hex
.047 Flexible	135-3336-001	.135 (3.43)	.105 (2.67) x .250 (6.35) W
	135-3336-401	.135 (3.43)	.105 (2.67) x .250 (6.35) W
RG-178/U, 196	135-3302-001	.185 (4.67)	.105 (2.67) x .250 (6.35) W
	135-3302-401	.185 (4.67)	.105 (2.67) x .250 (6.35) W
.047 Flexible	135-9436-001	.135 (3.43)	.105 (2.67) x .250 (6.35) W
RG-178/U, 196	135-9402-001	.185 (4.67)	.105 (2.67) x .250 (6.35) W

### MCX Solder Type Straight Plug for Semi-Rigid Cable

1. Identify connector parts. (2 piece parts)
2. Strip cable to dimensions shown. Do not nick center conductor.
3. Place center contact on center conductor making sure contact bottoms against cable insulation. Solder center conductor to center contact through solder hole. Solder must not be allowed to run on outside of contact. Use a minimum amount of solder for a good joint. .020 (0.51) diameter solder is recommended. Trim excess insulation.
4. Insert contact and cable into body assembly making sure cable is bottomed against insulator in body. Solder body to cable. Use a minimum amount of heat to minimize cable insulation movement.

Cable Group	Part No.
RG-405/U (.086 Semi-Rigid)	133-3693-001
	133-3693-006

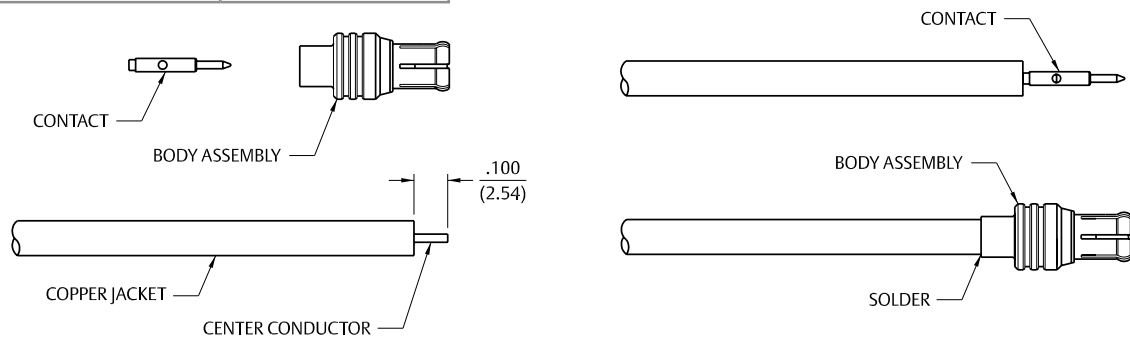

### MCX Solder Type Right Angle Plug for Semi-Rigid Cable

1. Identify connector parts. (3 piece parts)
2. Strip cable to dimensions shown. Do not nick center conductor.
3. Insert cable into body making sure cable insulation bottoms on center contact. Solder center conductor to contact through the rear access port. Use a minimum amount of solder for a good joint. .020 (0.51) diameter solder is recommended.
4. Solder body to cable. Use a minimum amount of heat to minimize cable insulation movement. Assemble insulator then place expansion cap in access port and seat with a .156 (3.96) diameter punch or hand tool 141-0000-908.

Cable Group	Part No.
RG-405/U (.086 Semi-Rigid)	133-3693-101
	133-3693-106

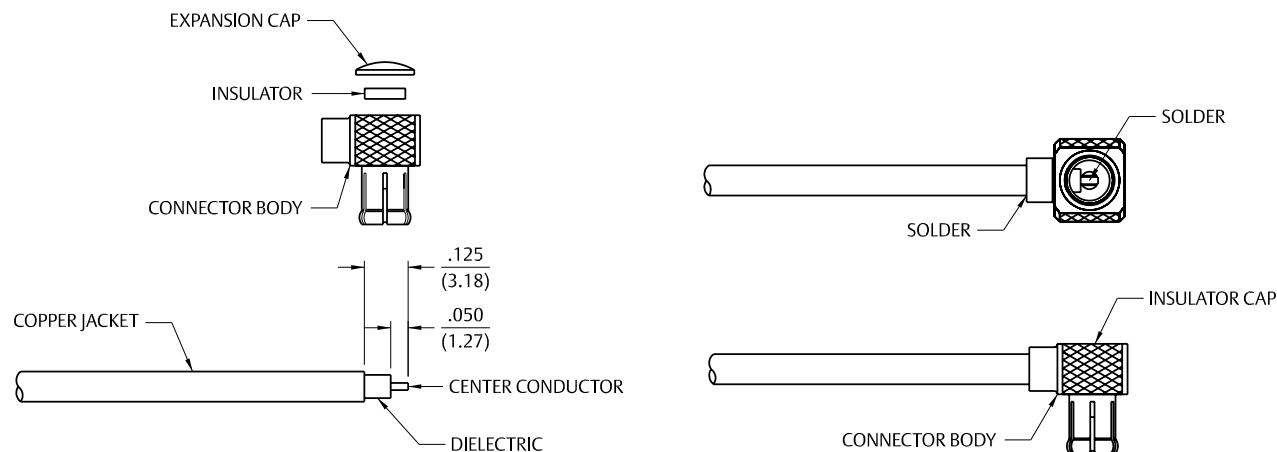

### MCX Crimp Type Straight Connectors for Flexible Cable

1. Identify connector parts. (3 piece parts – except bulkhead)
2. Strip cable to dimensions shown. Do not nick braid or center conductor. Tin center conductor if contact is to be solder attached. Do not tin center conductor if contact is to be crimp attached. Slide heat shrink (as applicable) and crimp sleeve onto jacket of cable.
3. Assemble contact onto cable as shown.
 

**Solder attachment.** Solder contact to center conductor through solder hole using .020 (0.51) diameter solder. Use a minimum of solder for a good joint.

**Crimp attachment.** Crimp contact to center conductor using a miniature 8 indent tool 140-0000-970 with positioner 140-0000-971. Crimp location should be centered between end of contact and cross hole. Crimp attachment to solid center conductor cable is not recommended.
4. Flair braid and slide body assembly over contact and under braid. Then seat body assembly firmly onto contact. (RG-178 is non-captivated, RG-316 incorporates snap-fit captivation.) The cable may have to be held in a clamping fixture. Arrange braid uniformly around crimp stem. Slide crimp sleeve forward and crimp using recommended crimp tool. Slide heat shrink forward and shrink (as applicable).

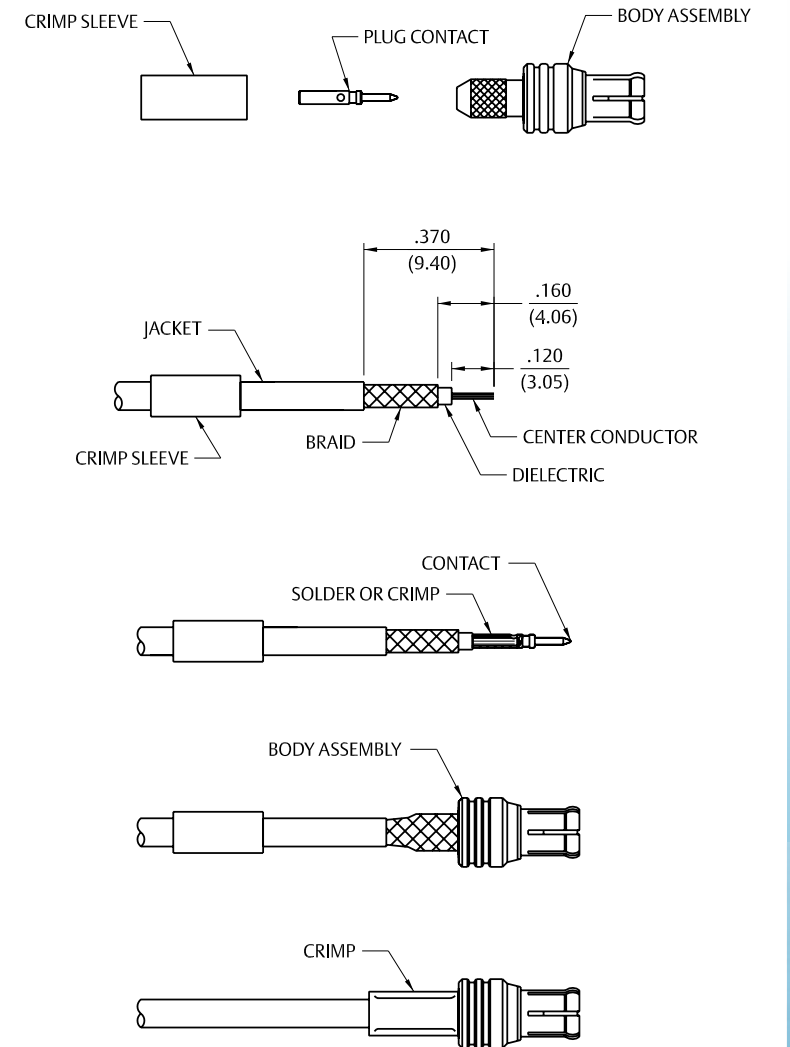

Cable Group	Part No.	Crimp Hex
RG-178/U, 196	133-3302-001/006	.105 (2.67)
	133-3302-401/406	.105 (2.67)
RG-316/U, 161, 174, 188	133-3303-001/006	.128 (3.25)
	133-3303-401/406	.128 (3.25)
RG-316 DS, 188 DS	133-3304-001/006	.151 (3.83)
	133-3304-401/406	.151 (3.83)
RG-178/U, 196	133-3402-001/006	.105 (2.67)
RG-316/U, 161, 174, 188	133-3403-001/006	.128 (3.25)
RG-316 DS, 188 DS	133-3404-001/006	.151 (3.83)
RG-179/U, 187	133-3433-001/006	.128 (3.25)
RG-178/U, 196	133-5302-401/406	.105 (2.67)
RG-316/U, 161, 174, 188	133-5303-401/406	.128 (3.25)
RG-316 DS, 188 DS	133-5304-401/406	.151 (3.83)
RG-178/U, 196	133-5402-001/006	.105 (2.67)
RG-316/U, 161, 174, 188	133-5403-001/006	.128 (3.25)
RG-316 DS, 188 DS	133-5404-001/006	.151 (3.83)
RG-316/U, 188, 174	133-9403-001	.128 (3.25)
RG-316 DS, 188 DS	133-9404-001	.151 (3.83)

For more information, please contact customer service at (507) 833-8822 or (800) 247-8256 • [www.EmersonConnectivity.com](http://www.EmersonConnectivity.com)

Illustrations are shown in inches (millimeters).



### MCX Crimp Type Right Angle Plugs for Flexible Cable

1. Identify connector parts. (4 piece parts).
2. Strip cable to dimensions shown. Do not nick braid or center conductor. A wire stripper of correct size is recommended for this step. Twist stranded center conductor into tight bundle and tin (optional). Slide crimp sleeve onto cable as shown.
3. Flare braid and slide cable into body making certain that the cable dielectric bottoms against center contact. Solder: Solder center conductor to contact through the side access ports and hole in center contact. Use a minimum amount of solder for a full fillet joint. .015 (0.38) diameter solder is recommended. Crimp: Crimp Contact Attachment Crimp contact using 41-0000-924 dieset in 144-0000-900 tool frame.
4. Arrange braid uniformly around crimp stem. Slide crimp sleeve over braid and access ports. Crimp securely using recommended hex size and crimp tool.

Cable Group	Part No.	Sleeve Hex
RG-316/U, 188, 174	133-9403-101/104	.128 (3.25)
RG-316 DS, 188 DS	133-9404-101	.151 (3.83)
RG-178	133-9402-101	.105 (2.67)

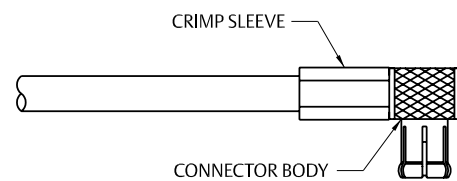
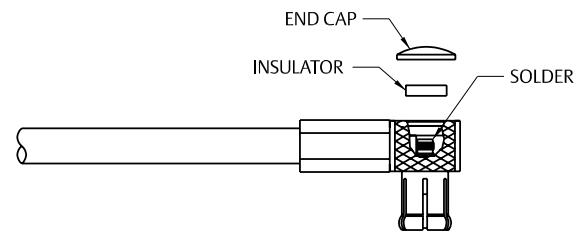
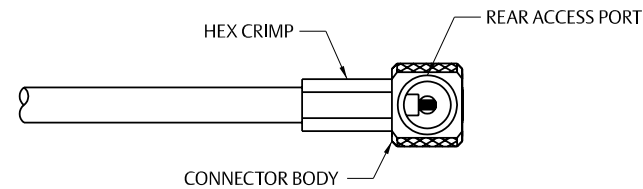
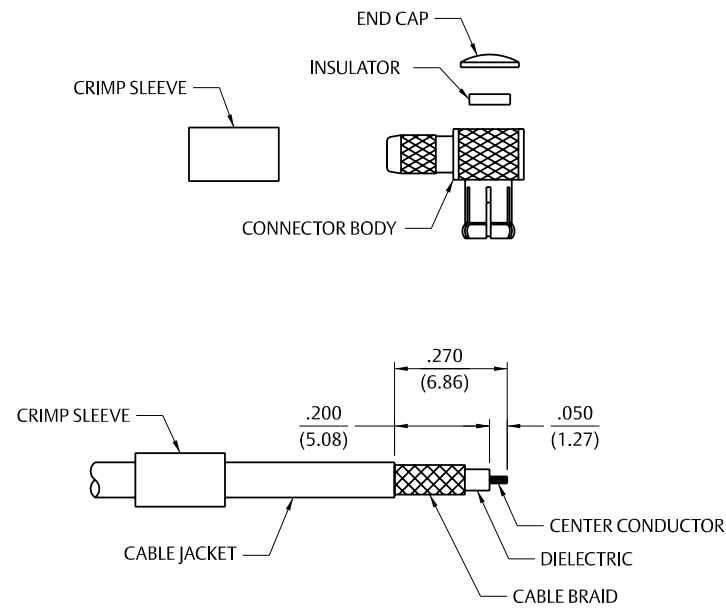

### MCX Crimp Type Straight Connectors for Flexible Cable – 75 Ohm

1. Identify connector parts. (2 piece parts—except bulkhead)
2. Strip cable to dimensions shown. Do not nick braid or center conductor. A wire stripper of correct size is recommended for this step. Twist stranded center conductor into tight bundle and tin (optional). Slide crimp sleeve onto cable as shown.
3. Flare braid and slide cable into body making certain that the cable dielectric bottoms against center contact. **Solder:** Solder center conductor to contact through the side access ports and hole in center contact. Use a minimum amount of solder for a full fillet joint. .015 (0.38) diameter solder is recommended. **Crimp:** Crimp Contact Attachment: Crimp contact using 141-0000-924 dieset in 144-0000-900 tool frame.
4. Arrange braid uniformly around crimp stem. Slide crimp sleeve over braid and access ports. Crimp securely using recommended hex size and crimp tool.

Cable Group	Part No.	Crimp Hex
RG-179	133-8433-001	.128 (3.25)
RG-179 DS	133-8434-001	.151 (3.83)
RG-179	133-8333-001	.128 (3.25)
RG-179 DS	133-8334-001	.151 (3.83)
RG-179	133-8333-401	.128 (3.25)
RG-179 DS	133-8334-401	.151 (3.83)
BELDEN 735A	133-8445-001	.151 (3.83)

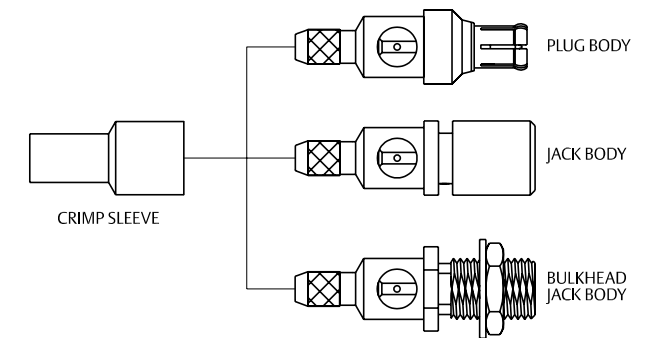
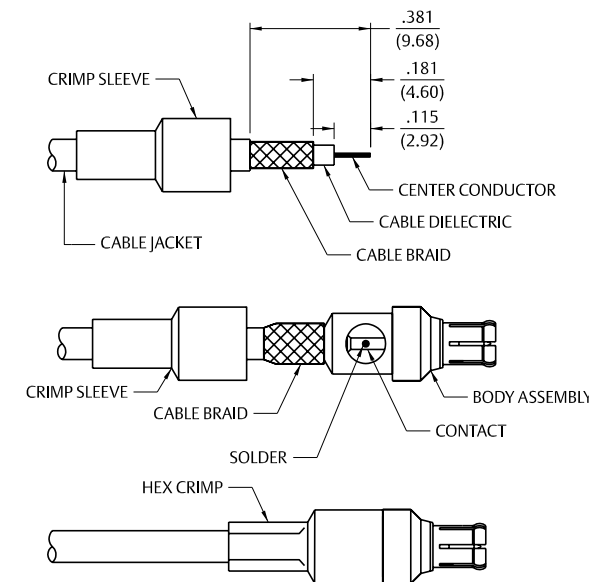

### MCX Crimp Type Right Angle Plugs for Flexible Cable – 50 Ohm

1. Identify connector parts. (4 piece parts except RG-58)
2. Strip cable to dimensions shown. Do not nick braid or center conductor. A wire stripper of correct size is recommended for this step. Twist stranded center conductor into tight bundle and tin (optional). Slide crimp sleeve onto cable shown.
3. Flair braid and slide cable into body making certain that the cable insulation bottoms on center contact. Arrange braid uniformly around crimp stem. Slide crimp sleeve over braid and crimp securely using recommended crimp tool.
4. Solder center conductor to contact through rear access port. Use a minimum amount of solder for a full fillet joint. .020 (0.51) diameter solder is recommended.
5. Assemble insulator, if applicable; then place expansion cap in access port and seat with .156 (3.96) diameter flat punch or MCX hand assembly tool 141-0000-908. Shrink heat shrink tubing over crimp sleeve if applicable.

Cable Group	Part No.	"A"	"B"	"C"	Crimp Hex
RG-178/U, 196	133-3402-101/106	.050 (1.27)	.270 (6.86)	.200 (5.08)	.105 (2.67)
RG-188/U, 316, 161, 174	133-3403-101/106	.050 (1.27)	.270 (6.86)	.200 (5.08)	.128 (3.25)
RG-316 DS, 188 DS	133-3404-101/106	.050 (1.27)	.270 (6.86)	.200 (5.08)	.151 (3.83)
RG-179/U, 187	133-3433-101/106	.050 (1.27)	.270 (6.86)	.200 (5.08)	.128 (3.25)
RG-178/U, 196	133-5402-101/106	.050 (1.27)	.270 (6.86)	.200 (5.08)	.105 (2.67)
RG-188/U, 316, 161, 174	133-5403-101/106	.050 (1.27)	.270 (6.86)	.200 (5.08)	.128 (3.25)
RG-316 DS, 188 DS	133-5404-101/106	.050 (1.27)	.270 (6.86)	.200 (5.08)	.151 (3.83)
RG-58/U, 303, 141	133-3407-101/106	.067 (1.70)	.295 (7.49)	.210 (5.33)	.213 (5.41)

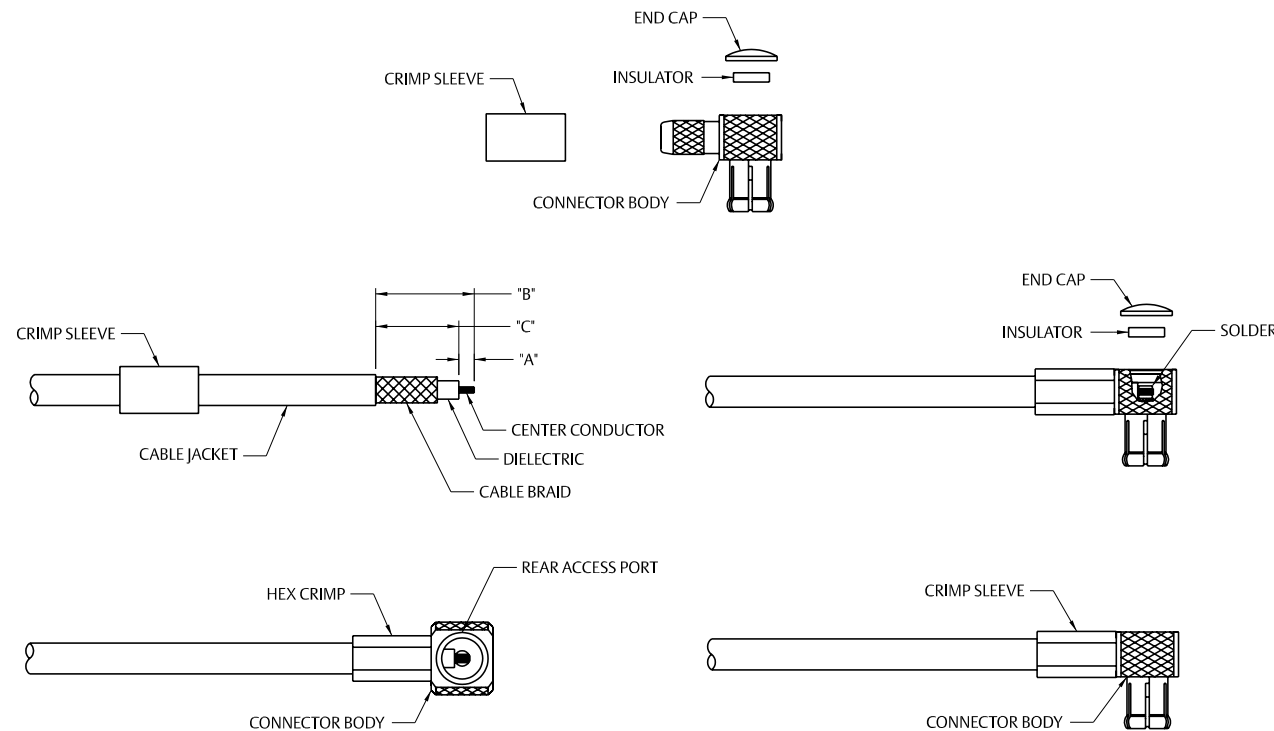

### MCX Crimp Type Right Angle Plugs for Flexible Cable – 75 Ohm

1. Identify connector parts (3-piece parts).
2. Strip cable to dimensions shown. Do not nick braid or center conductor. A wire stripper of correct size is recommended for this step. Twist stranded center conductor into tight bundle and tin (optional). Slide crimp sleeve onto cable as shown.
3. Flair braid and slide cable into body making certain that the cable dielectric bottoms on center contact. Arrange braid uniformly around crimp stem. Slide crimp sleeve over braid and crimp securely using recommended crimp tool.
4. Solder center conductor to contact through rear access port. Use a minimum amount of solder for a full fillet joint. .020 (0.51) diameter solder is recommended.
5. Place expansion cap in access port and seat with .156 (3.96) diameter flat punch or MCX hand assembly tool 141-0000-908. Shrink heat shrink tubing over crimp sleeve if applicable.

Cable Group	Part No.	Crimp Hex
RG-179	133-8433-101	.128 (3.25)
RG-179 DS	133-8434-101	.151 (3.83)
BELDEN 735A	133-8445-101	.151 (3.83)

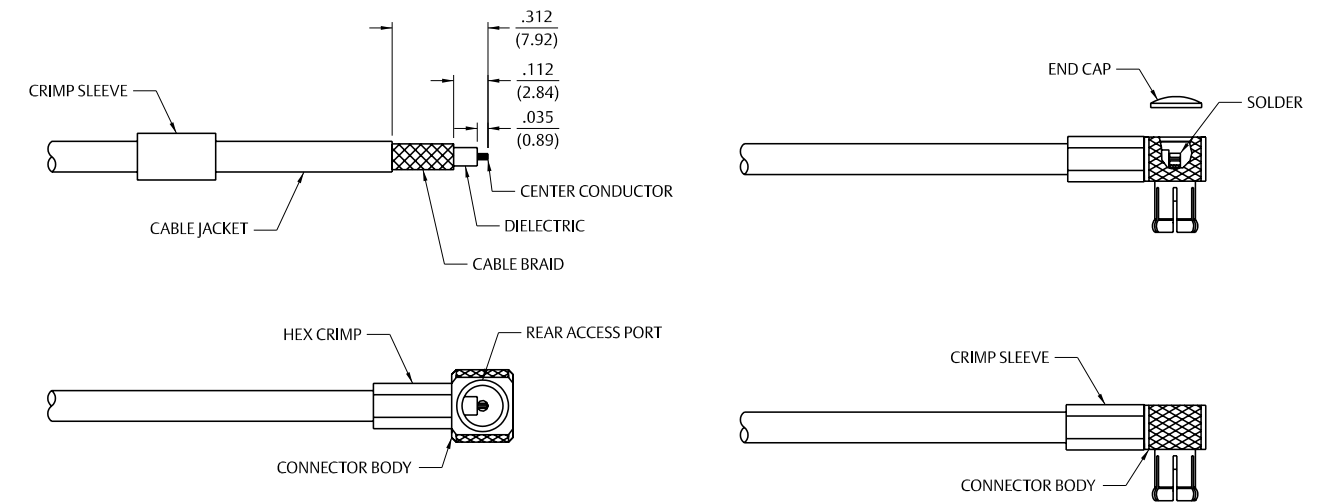

### SMK Solder Type Straight Plugs for Semi-Rigid Cable

1. Identify connector parts (5 piece parts) and tools (5 tools.)
2. Strip cable jacket and dielectric to dimension shown.
3. Place center contact onto center conductor. Slide contact soldering tool onto contact. Clamp the cable contact and tool into cable soldering vise and solder contact to center conductor. High temperature solder, such as 95/5 Sn/Ag is recommended so that contact solder joint remains stable during body soldering operation. Solder paste is recommended for the contact solder joint to minimize excess solder. The assembled contact dimension should be as shown.
4. Remove excess solder from contact with a sharp blade and clean contact. Check for presence of excess solder by sliding body soldering tool over the contact. Remove soldering tool.
5. Place connector nut and body on cable. Place connector body soldering tool over contact and thread the coupling nut and connector body firmly to the tool. Place cable subassembly into cable soldering vise. Clamp cable and soldering tool securely to insure the cable dielectric expansion will not disturb the cable in the vise during soldering. Place hot soldering iron on the connector body sleeve and apply solder from the opposite side. A low temp solder, such as 60/40 Sn/Pb is recommended for the body solder joint. Allow the soldered joint to cool and remove from fixture. Check contact location to the body. The best electrical results are achieved when the contact location is within a tolerance of .060 +/- .001.
6. Place bead onto neck portion of the tool. Thread Bead Assembly tool firmly into the coupling nut. Push the tool's plunger between your thumb and fingers to assemble the bead. Check bead location. Assemble seal ring onto body.



Tool	145-0693-001/002 (for .086 Semi-Rigid)	145-0694-001/02 (for .141 Semi-Rigid)
Semi-Rigid Cable Vise	140-0000-962	140-0000-962
Vise Stop	140-0000-968	140-0000-968
Bead Assy. Tool	140-0000-957	140-0000-957
Contact Soldering Tool	140-0000-960	140-0000-961
Body Soldering Tool	140-0000-958	140-0000-959
Cable Clamp Insert	140-0000-964	140-0000-965

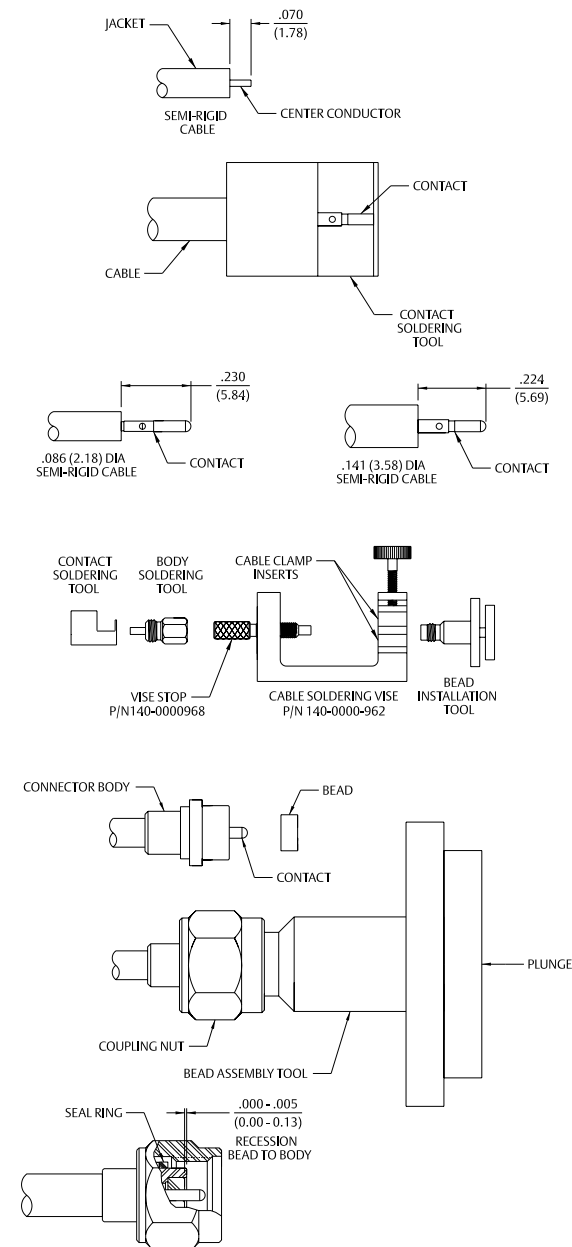
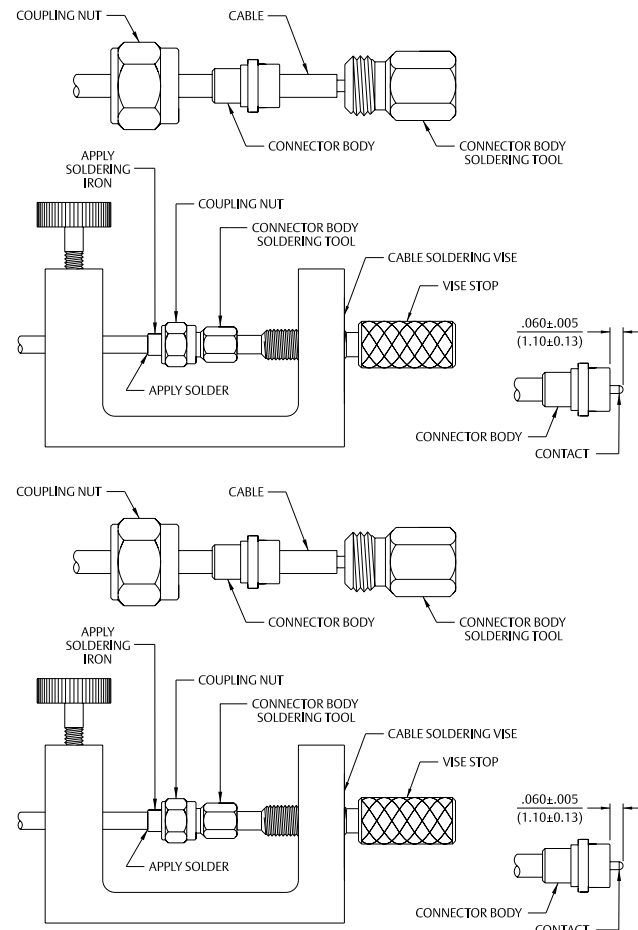

### SMA Right Angle Solder Type Plug for Semi-Rigid Cable

1. Identify connector parts. (2 piece parts)
2. Strip cable to dimensions shown. Do not nick center conductor during strip operations.
3. Insert cable into body making certain that the cable jacket is butted against internal body shoulder and cable dielectric is started into cross hole. Solder center conductor to contact using 60/40 tin/lead solder as shown. Use a minimum amount of solder for a good joint.
4. Solder body to cable using 60/40 tin/lead solder as shown. Use a minimum of heat to minimize cable dielectric growth. Any growth of cable dielectric shall be flush with contact.
5. Press end cap into body access port using .187 (4.75) dia. flat punch.

Cable Group	Part No.	"A"	"B"
RG-405/U (.086 Semi-Rigid)	142-0693-101/106	.145 (3.68)	.075 (1.90)
RG-402/U (.141 Semi-Rigid)	142-0694-101/106	.170 (4.32)	.105 (2.67)

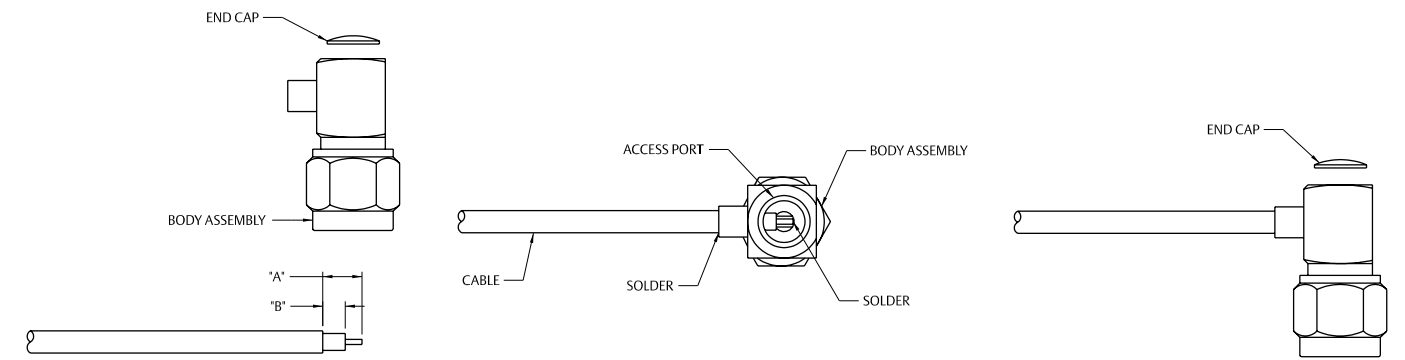

For more information, please contact customer service at (507) 833-8822 or (800) 247-8256 • [www.EmersonConnectivity.com](http://www.EmersonConnectivity.com)  
Illustrations are shown in inches (millimeters).

### SMA Solder Type Straight Jacks, Straight Plugs, and Straight Bulkhead Jacks for Semi-Rigid Cable

1. Identify connector parts. (2 piece parts)
2. Strip cable to dimensions shown. Do not nick center conductor.
3. Place center contact on center conductor making sure contact bottoms against cable insulation. Solder center conductor to center contact through solder hole. Solder must not be allowed to run on outside of contact. Use a minimum amount of solder for a good joint. .020 (0.51) diameter solder is recommended. Trim excess insulation.
4. Insert contact and cable into body assembly making sure cable is bottomed against insulator in body. Solder body to cable. Use a minimum amount of heat to minimize cable insulation movement.

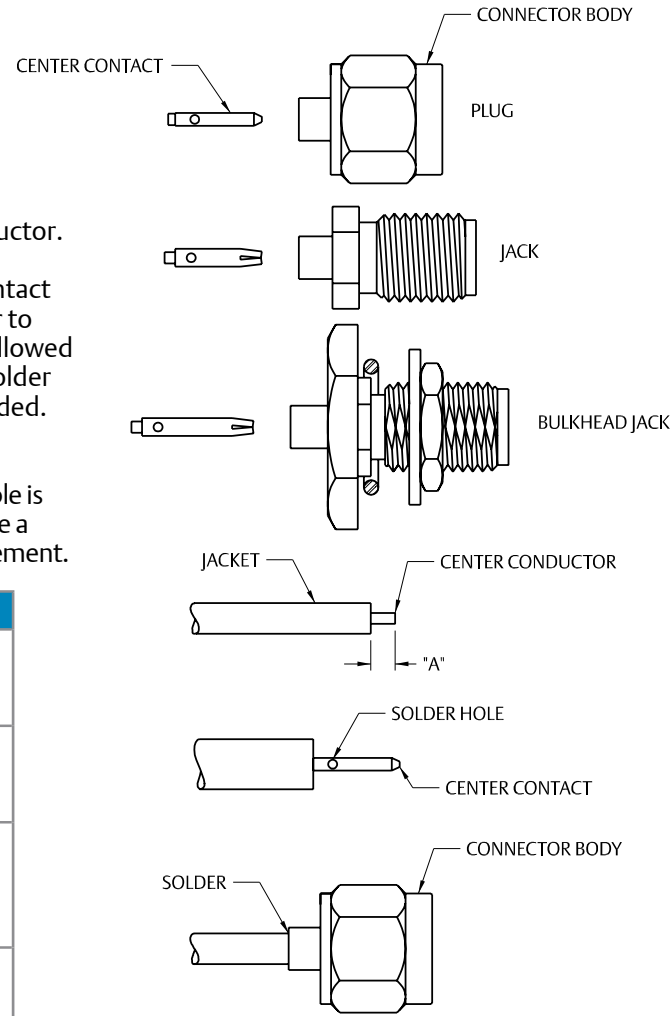

Cable Group	Part No.	"A"
RG-405/U (.086 Semi-Rigid)	141-0593-001	.070 (1.78)
	141-0593-401	.070 (1.78)
	141-0693-002	.070 (1.78)
RG-402/U (.141 Semi-Rigid)	141-0594-001	.085 (2.16)
	141-0594-401	.085 (2.16)
	141-0694-002	.085 (2.16)
RG-405/U (.086 Semi-Rigid)	142-0593-001/006	.070 (1.78)
	142-0593-401/406	.070 (1.78)
	142-0593-411/416	.070 (1.78)
	142-0693-001/006	.070 (1.78)
RG-402/U (.141 Semi-Rigid)	142-0594-001/006	.085 (2.16)
	142-0594-401/406	.085 (2.16)
	142-0694-001/006	.085 (2.16)

### SMA Solder Type Straight Plugs for Semi-Rigid Cable

1. Identify connector parts. (2 piece parts)
2. Strip cable to dimensions shown. Do not nick center conductor. Bevel the cable center conductor per contact detail of SMA interface on page 48. Slide coupling nut onto cable as shown.
3. Insert cable into body making sure cable jacket is flush with front of body. Solder body to cable. Use a minimum amount of heat to minimize cable insulation movement. Trim expanded insulation flush with front of body or fixture body and cable during soldering to prevent cable insulation expansion.
4. Thread coupling nut over body.

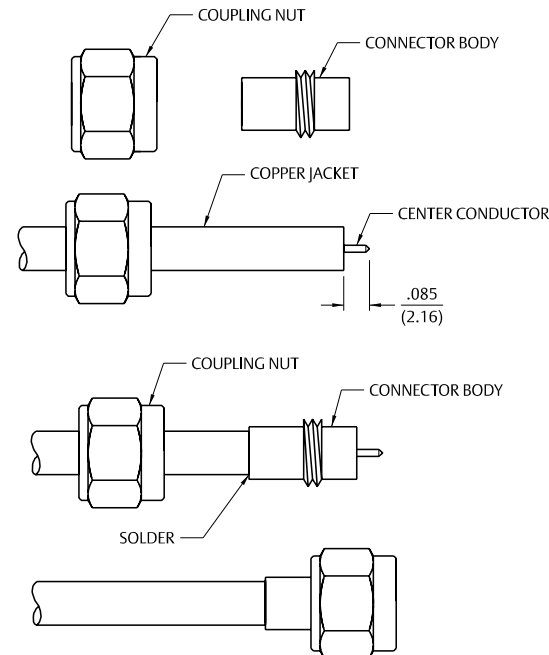

Cable Group	Part No.
RG-402/U (.141 Semi-Rigid)	142-0694-011
	142-0694-016
	141-0694-012

### SMA Solder Type Straight Plugs for Semi-Rigid Cable

1. Identify connector parts. (2 piece parts)
2. Strip cable to dimensions shown. Do not nick center conductor. Bevel the cable center conductor per contact detail of SMA interface on page 48. Slide coupling nut onto cable as shown.
3. Insert cable into body making sure cable jacket is bottomed against shoulder inside of body. Solder body to cable. Use a minimum amount of heat to minimize cable insulation movement. Trim expanded insulation flush with front of body or fixture body and cable during soldering to prevent insulation expansion.

Cable Group	Part No.
RG-402/U (.141 Semi-Rigid)	142-0694-021
	142-0694-026
	142-0694-041
	142-0694-046

4. Thread coupling nut over body.

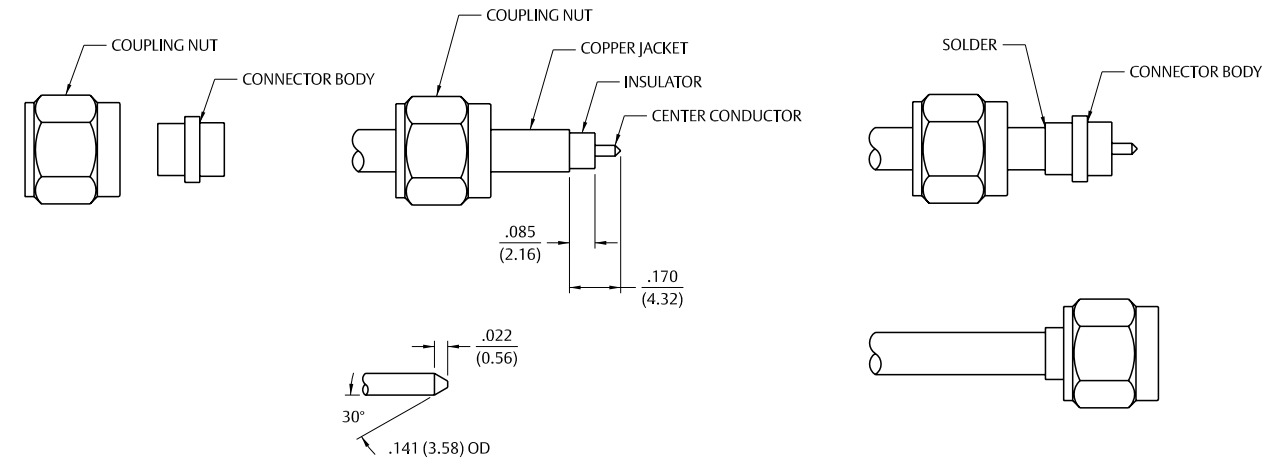

### SMA Solder Type Straight Plugs for Semi-Rigid Cable

1. Identify connector parts. (3 piece parts)
2. Strip cable to dimensions shown. Do not nick center conductor. Bevel the cable center conductor per contact detail of SMA interface on page 48.
3. Insert cable into body making sure cable jacket is flush with front of body. Solder body to cable. Use a minimum amount of heat to minimize cable insulation movement. Trim expanded cable insulation flush with front of body or fixture body and cable during soldering to prevent insulation expansion.
4. Snap "C" spring onto connector body groove. Compress "C" spring using 141-0000-904 compression tool. Install coupling nut onto connector body. Nut should spin freely.

Cable Group	Part No.
RG-402/U (.141 Semi-Rigid)	142-0694-031
	142-0694-036

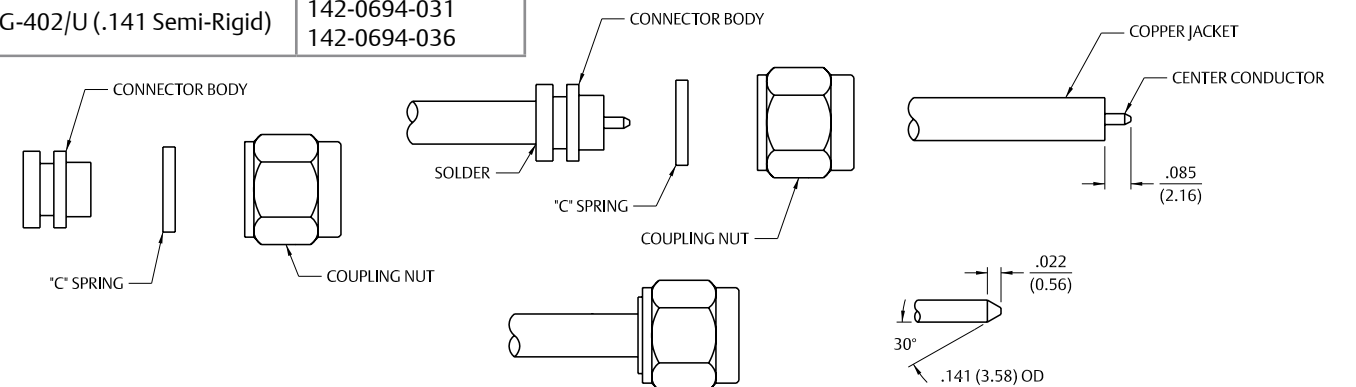

For more information, please contact customer service at (507) 833-8822 or (800) 247-8256 • www.EmersonConnectivity.com  
Illustrations are shown in inches (millimeters).

### SMA Solder Type Straight Plugs for Semi-Rigid Cable

1. Identify connector parts. (3 piece parts)
2. Strip cable to dimensions shown. Do not nick center conductor. Slide coupling nut onto cable as shown.
3. Place center contact on center conductor making sure contact bottoms against cable insulation. Solder center conductor to center contact through solder hole. Solder must not be allowed to run on outside of contact. Use a minimum amount of solder for a good joint. .020 (0.51) diameter solder is recommended. Trim excess insulation.
4. Insert contact and cable into body making sure cable is bottomed against insulator in body. Solder body to cable. Use a minimum amount of heat to minimize cable insulation movement.
5. Thread coupling nut over body

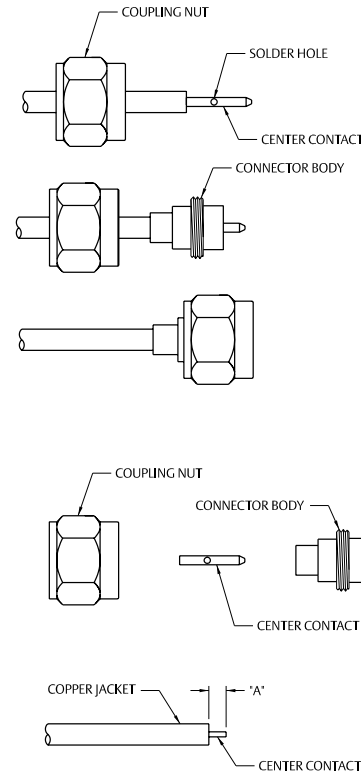

Cable Group	Part No.	"A"
RG-405/U (.086 Semi-Rigid)	142-0693-051	.070 (1.78)
	142-0693-056	.070 (1.78)
RG-402/U (.141 Semi-Rigid)	142-0694-051	.085 (2.16)
	142-0694-056	.085 (2.16)

### SMA Solder Type Antenna Connector Plug for Flexible or Semi-Rigid Cable

1. Identify connector parts. (2 piece parts)
2. Strip cable to dimensions shown. Do not nick center conductor or braid on flexible cable.
3. **Flexible Cable Attachment:** Twist stranded center conductor into tight bundle and tin (optional). Slide cable into body, making sure cable insulation bottoms on center contact and braid fits inside stem. Solder center conductor to contact through the side access ports. Use a minimum amount of solder for a good joint. .020 (0.51) diameter solder is recommended. Solder braid to body. Use a minimum amount of solder to completely join the braid to the body.  
**Semi-Rigid Cable Attachments:** Slide cable into body making certain cable insulation bottoms on center contact. Solder center conductor to contact through the side access ports. Use a minimum amount of solder for a good joint. .020 (0.51) diameter solder is recommended. Solder body to cable jacket. Use a minimum amount of heat to minimize cable insulation movement.

Cable Group	Part No.
RG-178/U, .047 Semi-Rigid	142-0801-421

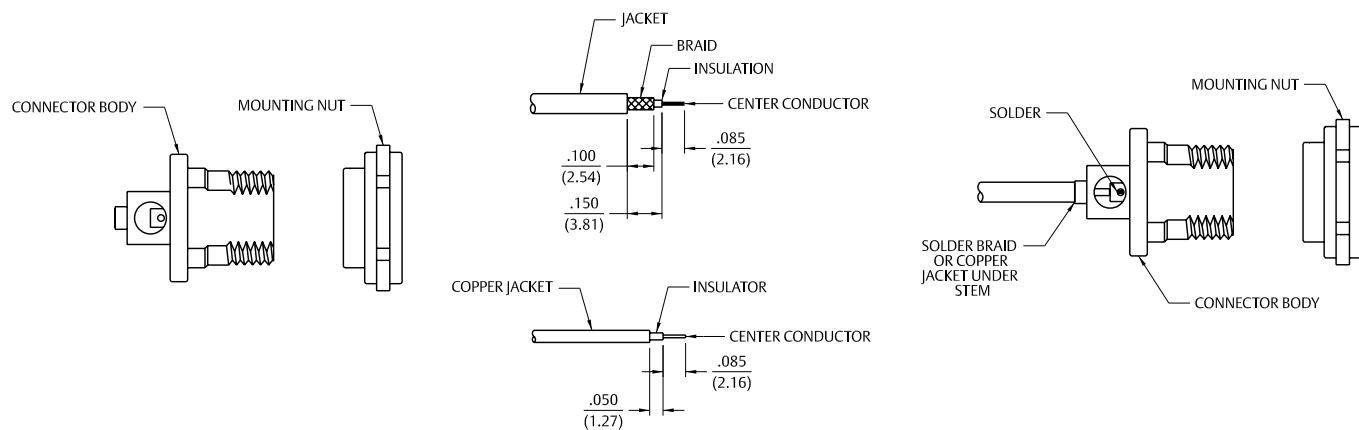

### SMA 3-Piece Plug, Jack and Bulkhead Jack for RG-178 Flexible Cable

1. Identify piece parts. (4 piece parts plus nut and washer for bulkhead.)
2. Strip cable jacket and braid to dimensions shown. Do not nick braid during strip operations.
3. Slide crimp insert over braid and against jacket. Fold braid around crimp insert as shown. Strip dielectric to dimension shown. If cable is being manually stripped the rear insulator can be assembled and used as a guide. Do not nick center conductor during strip operation. Tin center conductor if contact is to be solder attached. Do not tin center conductor if contact is to be crimp attached.
4. Assemble rear insulator over cable dielectric and contact over center conductor as shown.  
**Solder attachment:** Solder contact to center conductor using 60/40 tin/lead solder. Care should be taken that excess solder is not applied.  
**Crimp attachment:** Crimp contact to center conductor using production tooling or hand tool 144-0000-910, setting #2 with positioner 141-0000-907. Crimp location should be centered between end of contact and x-hole. Crimp attachment to solid center conductor cables is not recommended.
5. Slide body assembly over contact, rear insulator and crimp insert. Crimp body using recommended crimp tool. Maintain forward pressure on cable while crimping. Body crimp die hex: .105 (2.67) hex.

Cable Group	Part No.	Crimp Hex
RG-178/U, 196	142-0402-011	.105 (2.67)
	142-0402-016	.105 (2.67)
	142-0302-011	.105 (2.67)
	142-0302-016	.105 (2.67)
	142-0302-431	.105 (2.67)
	142-0302-436	.105 (2.67)

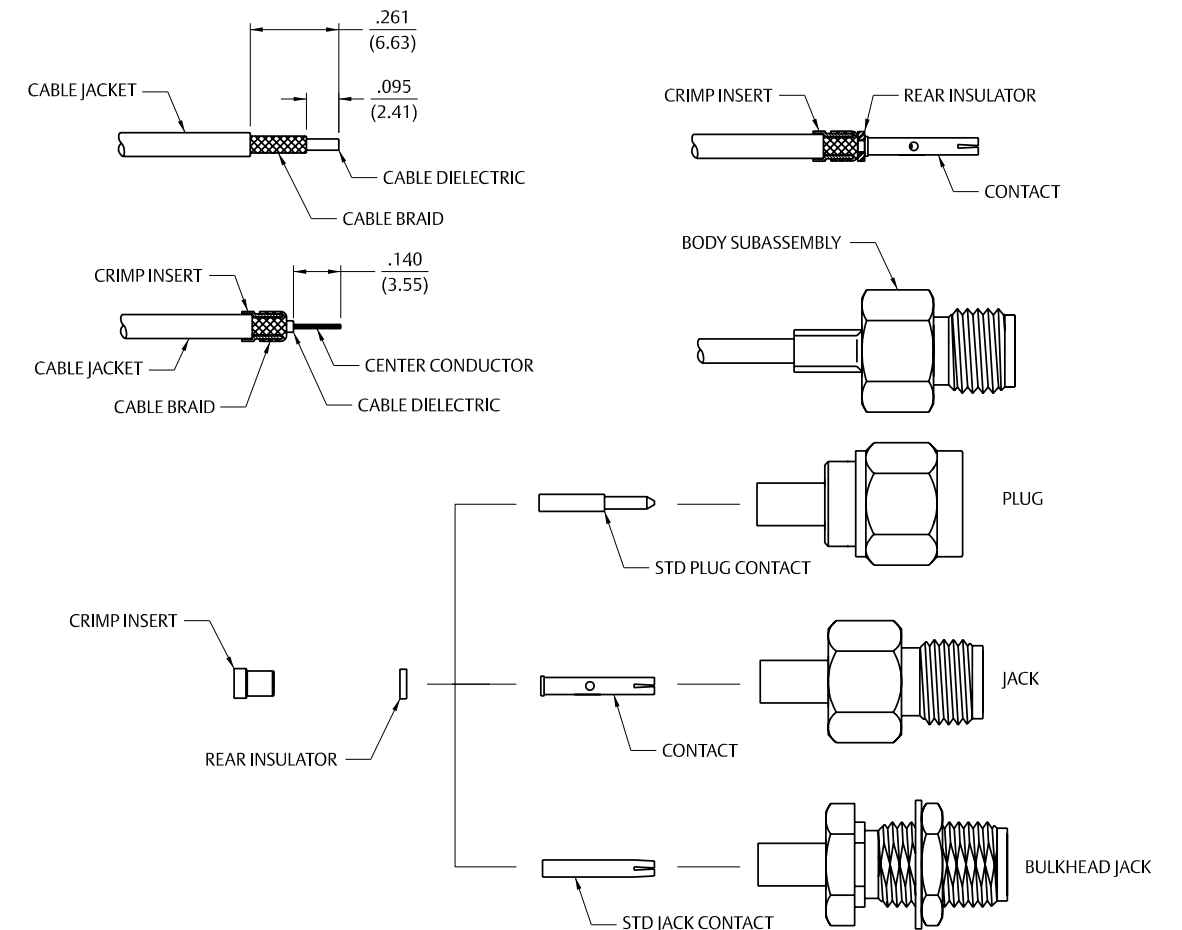

For more information, please contact customer service at (507) 833-8822 or (800) 247-8256 • www.EmersonConnectivity.com  
Illustrations are shown in inches (millimeters).

## SMA Type Straight Plugs, Straight Jacks, and Straight Bulkhead Jacks for Flexible Cable – Crimp or Solder Contacts

1. Identify connector parts. (3 piece parts – except bulkhead)
2. Strip cable to dimensions shown. Do not nick braid or center conductor. Tin center conductor if contact will be solder attached. Do not tin center conductor if contact is to be crimp attached. When stripping LMR-100 low loss cable, remove foil back to where cable jacket is stripped. A wire stripper of correct size is recommended for this step. Slide heat shrink (as applicable) and crimp sleeve onto jacket of cable.

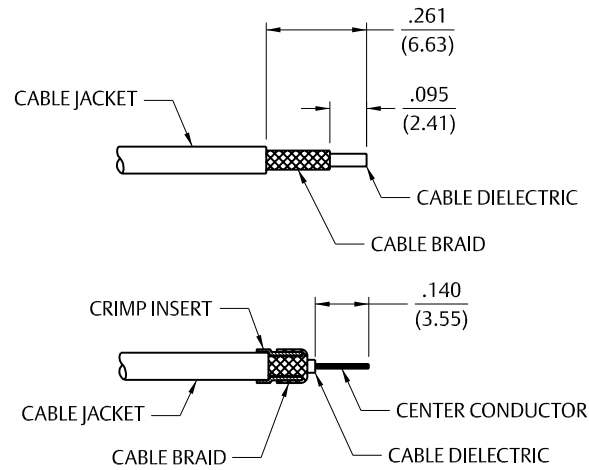

3. Assemble contact onto cable as shown.  
**Solder Attachment:** Solder contact to center conductor through solder hole using .020 (0.51) diameter solder. Use a minimum amount of solder for a good joint.  
**Crimp Attachment:** Crimp contact to center conductor using Johnson Hand Tool 144-0000-910, setting #2, with positioner 141-0000-907. Crimp location should be centered between end of contact and X-hole. Crimp attachment to solid center conductor cables is not recommended.

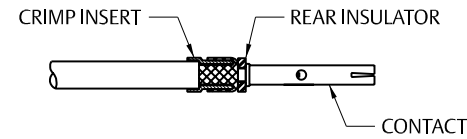

4. Flare braid and slide body assembly over contact and under braid. Then seat body assembly firmly onto contact. The cable may have to be held in a clamping fixture. Arrange braid uniformly around crimp stem. Slide crimp sleeve forward and crimp using recommended crimp tool. Slide heat shrink forward and shrink (as applicable).

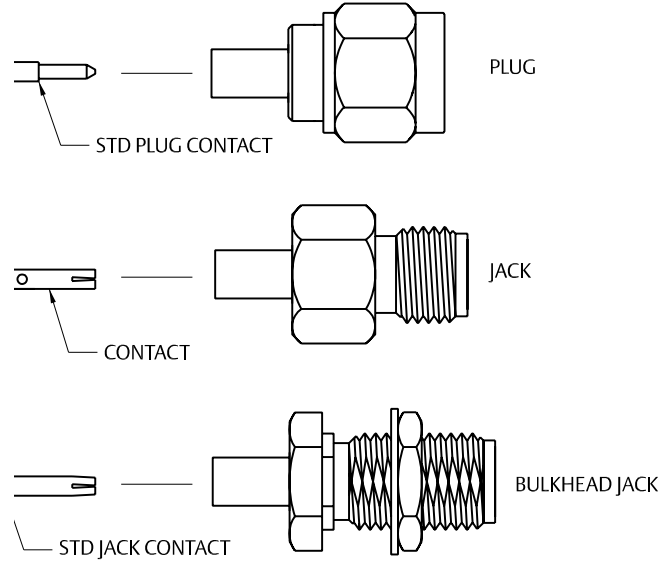
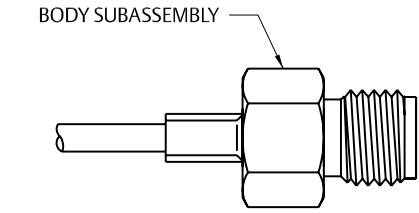

## SMA Type Straight Plugs, Straight Jacks, and Straight Bulkhead Jacks for Flexible Cable – Crimp or Solder Contacts (cont'd from last page)

Cable Group	Part No.	"A"	"B"	Crimp Hex
RG-316/U, 161, 174, 188; LMR-100	141-0303-412	.128 (3.25)	.270 (6.86)	.105 (2.67)
RG-316 DS, 188 DS	141-0304-412	.151 (3.83)	.270 (6.86)	.128 (3.25)
RG-58/U, 141, 303	141-0307-412	.213 (5.41)	.270 (6.86)	.151 (3.83)
RG-55/U, 142, 223, 400	141-0308-412	.213 (5.41)	.270 (6.86)	.128 (3.25)
RG-316/U, 161, 174, 188; LMR-100	141-0403-012	.128 (3.25)	.270 (6.86)	.105 (2.67)
RG-316 DS, 188 DS	141-0404-012	.151 (3.83)	.270 (6.86)	.128 (3.25)
RG-58/U, 141, 303	141-0407-012	.213 (5.41)	.270 (6.86)	.151 (3.83)
RG-55/U, 142, 223, 400	141-0408-012	.213 (5.41)	.295 (7.49)	.213 (5.41)
RG-316/U, 161, 174, 188; LMR-100	142-0303-011/016 142-0303-411/416 142-9303-411	.215 (5.46) .215 (5.46)	.278 (7.06) .278 (7.06)	.128 (3.25) .128 (3.25)
RG-316 DS, 188 DS	142-0304-011/016 142-0304-411/416	.215 (5.46) .215 (5.46)	.278 (7.06) .278 (7.06)	.151 (3.83) .151 (3.83)
RG-58/U, 141, 303	142-0307-011/016 142-0307-411/416	.215 (5.46) .215 (5.46)	.278 (7.06) .278 (7.06)	.213 (5.41) .213 (5.41)
RG-55/U, 142, 223, 400	142-0308-011/016 142-0308-411/416	.215 (5.46) .215 (5.46)	.278 (7.06) .278 (7.06)	.213 (5.41) .213 (5.41)
RG-179/U, 187	142-0333-011/016 142-0333-411/416	.215 (5.46) .215 (5.46)	.278 (7.06) .278 (7.06)	.128 (3.25) .128 (3.25)
RG-316/U, 161, 174, 188; LMR-100	142-0403-011/016	.215 (5.46)	.278 (7.06)	.128 (3.25)
RG-316 DS, 188 DS	142-0404-011/016	.215 (5.46)	.278 (7.06)	.151 (3.83)
RG-58/U, 141, 303	142-0407-011/016	.215 (5.46)	.278 (7.06)	.213 (5.41)
RG-55/U, 142, 223, 400	142-0408-011/016	.215 (5.46)	.278 (7.06)	.213 (5.41)
RG-179/U, 187	142-0433-011/016	.215 (5.46)	.278 (7.06)	.128 (3.25)
RG-316/U, 161, 174, 188; LMR-100	142-1403-001/006	.280 (7.11)	.715 (18.16)	.128 (3.25)
RG-316 DS, 188 DS	142-1404-001/006	.280 (7.11)	.715 (18.16)	.151 (3.83)
RG-58/U, 141, 303	142-1407-001/006	.280 (7.11)	.715 (18.16)	.213 (5.41)
RG-55/U, 142, 223, 400	142-1408-001/006	.280 (7.11)	.715 (18.16)	.213 (5.41)
RG-316/U, 161, 174, 188; LMR-100	142-4303-401/406	.215 (5.46)	.278 (7.06)	.128 (3.25)
RG-316 DS, 188 DS	142-4304-401/406	.215 (5.46)	.278 (7.06)	.151 (3.83)
RG-58/U, 141, 303	142-4307-401/406	.215 (5.46)	.278 (7.06)	.213 (5.41)
RG-55/u, 142, 223, 400	142-4308-401/406	.215 (5.46)	.278 (7.06)	.213 (5.41)
RG-316/U, 161, 174, 188; LMR-100	142-4403-001/006	.215 (5.46)	.278 (7.06)	.128 (3.25)
RG-316 DS, 188 DS	142-4404-001/006	.215 (5.46)	.278 (7.06)	.151 (3.83)
RG-58/U, 141, 303	142-4407-001/006	.215 (5.46)	.278 (7.06)	.213 (5.41)
RG-55/U, 142, 223, 400	142-4408-001/006	.215 (5.46)	.278 (7.06)	.213 (5.41)
RG-316/U, 161, 174, 188; LMR-100	142-5303-401/406	.215 (5.46)	.278 (7.06)	.128 (3.25)
RG-316 DS, 188 DS	142-5304-401/406	.215 (5.46)	.278 (7.06)	.151 (3.83)
RG-58/U, 141, 303	142-5307-401/406	.215 (5.46)	.278 (7.06)	.213 (5.41)
RG-55/U, 142, 223, 400	142-5308-401/406	.215 (5.46)	.278 (7.06)	.213 (5.41)
RG-316/U, 161, 174, 188; LMR-100	142-5403-001/006	.215 (5.46)	.278 (7.06)	.128 (3.25)
RG-316 DS, 18 DS	142-5404-001/006	.215 (5.46)	.278 (7.06)	.151 (3.83)
RG-58/U, 141, 303	142-5407-001/006	.215 (5.46)	.278 (7.06)	.213 (5.41)
RG-55/U, 142, 223, 400	142-5408-001/006	.215 (5.46)	.278 (7.06)	.213 (5.41)
RG-316/U, 161, 174, 188; LMR-100	142-9403-011	.215 (5.46)	.278 (7.06)	.128 (3.25)
RG-316 DS, 188 DS	142-9404-011	.215 (5.46)	.278 (7.06)	.151 (3.83)
RG-58/U, 141, 303	142-9407-011	.215 (5.46)	.278 (7.06)	.213 (5.41)

For more information, please contact customer service at (507) 833-8822 or (800) 247-8256 • [www.EmersonConnectivity.com](http://www.EmersonConnectivity.com)

Illustrations are shown in inches (millimeters).

### Straight SMA Low Loss Diameter .195, .200 and .240 Straight Type Plugs

1. Identify connector parts. (3 piece parts – except bulkhead)
2. Strip cable to dimensions shown. Do not nick braid, foil or center conductor. Cut foil flush with dielectric, do not remove foil. Make sure that dielectric is clean and free from all particles. Tin center conductor, keeping solder amount to a minimum. Slide crimp sleeve onto jacket of cable.
3. Assemble contact onto cable as shown. Position contact such that a gap of no more than .020 (0.51) is kept between dielectric and contact. Solder contact to center conductor through solder hole using .020 (0.51) Diameter solder. Use a minimum amount of solder for a good joint. Do not allow contact to move into dielectric during soldering process.
4. Flare braid and slide body assembly over contact, foil and dielectric, then under braid. Seat body assembly firmly onto contact. Arrange braid uniformly around crimp stem. Slide crimp sleeve forward and crimp using Johnson hand crimp tool 141-0000-913 and recommended crimp die hex.

Cable Group	Part No.	Crimp Hex
LMR-195	142-0307-411	.213 (5.41)
	142-0307-416	.213 (5.41)
LMR-240	142-0335-401	.255 (6.48)
	142-0335-406	.255 (6.48)
LMR-200	142-0339-401	.213 (5.41)
	142-0339-406	.213 (5.41)
LMR-195	142-0407-011	.213 (5.41)
	142-0407-016	.213 (5.41)
LMR-240	142-0435-001	.255 (6.48)
	142-0435-006	.255 (6.48)
LMR-200	142-0439-001	.213 (5.41)
	142-0439-006	.213 (5.41)
LMR-240	142-4435-001	.255 (6.48)
	142-4435-006	.255 (6.48)
LMR-200	142-4439-001	.213 (5.41)
	142-4439-006	.213 (5.41)
LMR-195	142-4407-001	.213 (5.41)
	142-4407-006	.213 (5.41)
LMR-240	142-5435-001	.255 (6.48)
	142-5435-006	.255 (6.48)
LMR-200	142-5439-001	.213 (5.41)
	142-5439-006	.213 (5.41)
LMR-195	142-5407-001	.213 (5.41)
	142-5407-006	.213 (5.41)

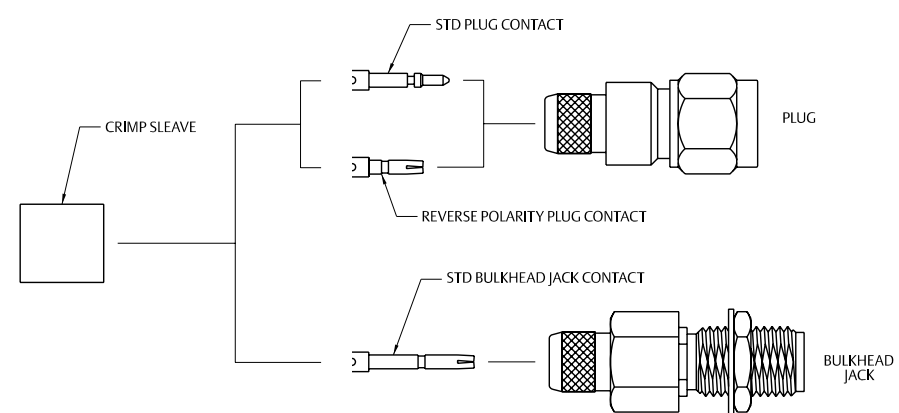
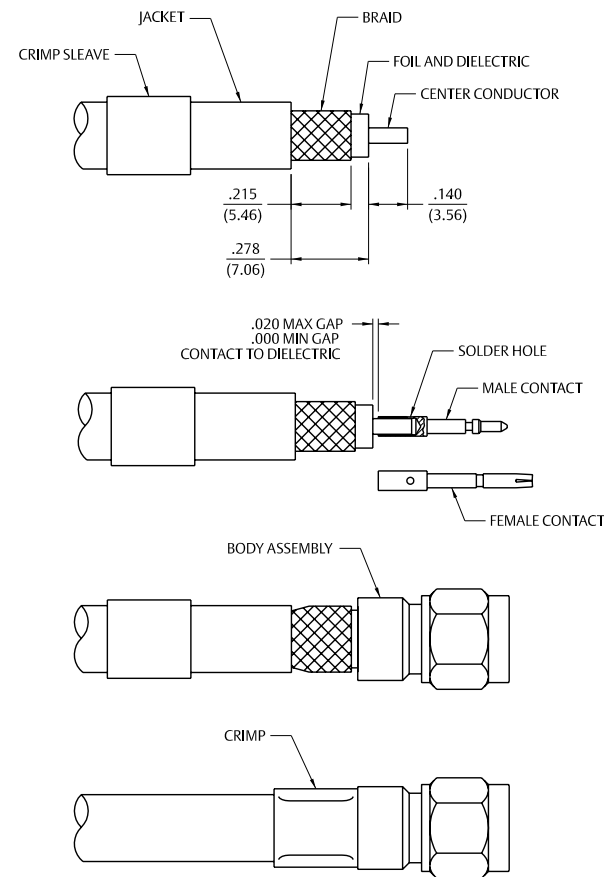

### SMA Straight Solder Type for Semi-Rigid Cables

1. Identify the connector (plug or jack) and tools.
2. Strip the cable jacket and dielectric to dimension shown. Do not nick the center conductor.
3. Bevel the entire diameter on the end of the cable center conductor until the point resembles the appropriate dimensional profile. This operation can be accomplished effectively by using the recommended center conductor pointing tool as described in step 4.
4. Insert the stripped cable into the bushing of the appropriate pointing tool until the center conductor just touches the blade. While maintaining light pressure on the center conductor against the blade, turn the tool in a counter-clockwise fashion as viewed from the bushing end of the tool. Continue cutting the center conductor point until the cable jacket bottoms out inside the bushing.
5. Attach the appropriate soldering mating fixture to the connector and tighten to a maximum of 8 inch pounds of torque.
6. Clean all debris from the prepared cable and insert the cable into the connector, making sure that the cable jacket bottoms out against the internal shoulder of the connector body.
7. Insert the stop screw into the mating fixture. Clamp the cable and fixtured connector assembly securely in the soldering vise. Solder the connector body to the cable as shown, while insuring the cable dielectric expansion does not move the assembly. Allow the assembly to cool before removing the connector from the fixture.

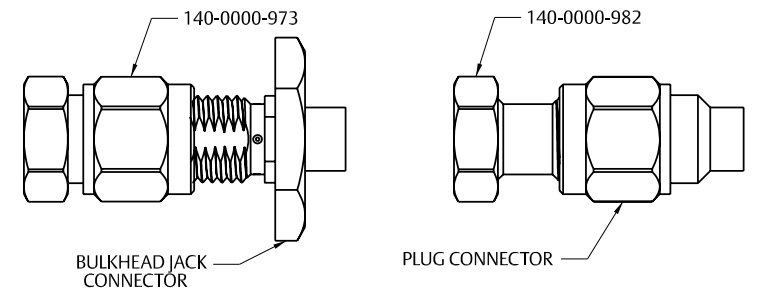
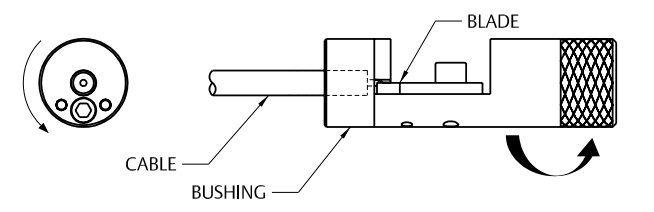
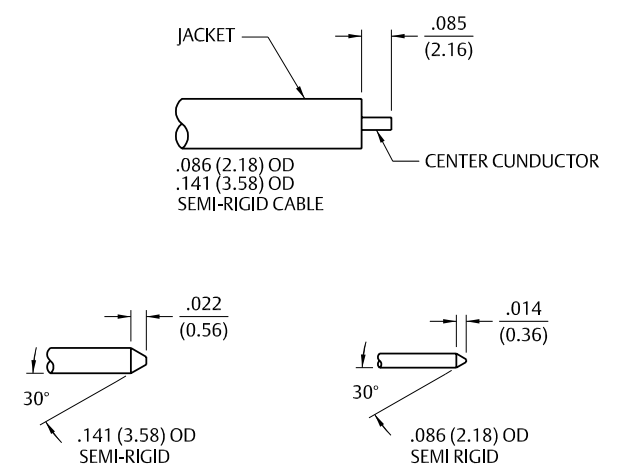
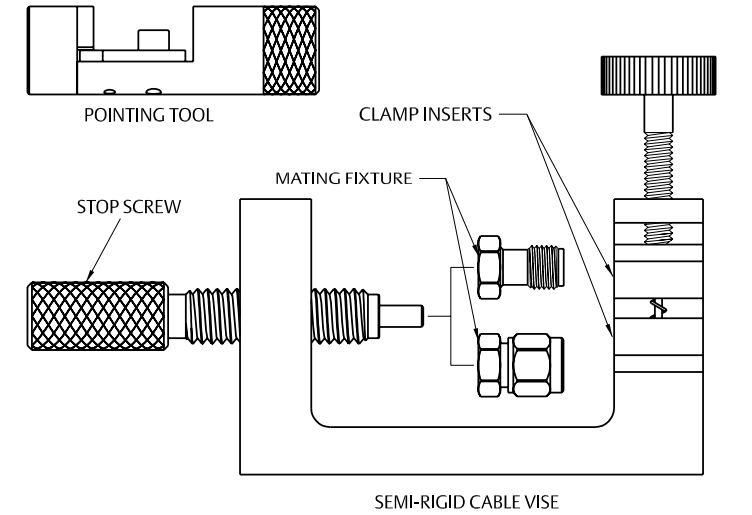

For more information, please contact customer service at (507) 833-8822 or (800) 247-8256 • www.EmersonConnectivity.com  
Illustrations are shown in inches (millimeters).

### SMA Straight Solder Type for Semi-Rigid Cables (cont'd from last page)

Cable Group	Part No.
RG-405/U (.086 Semi-Rigid)	141-0593-421 141-0693-062
RG-402/U (.141 Semi-Rigid)	141-0594-421 141-0694-062

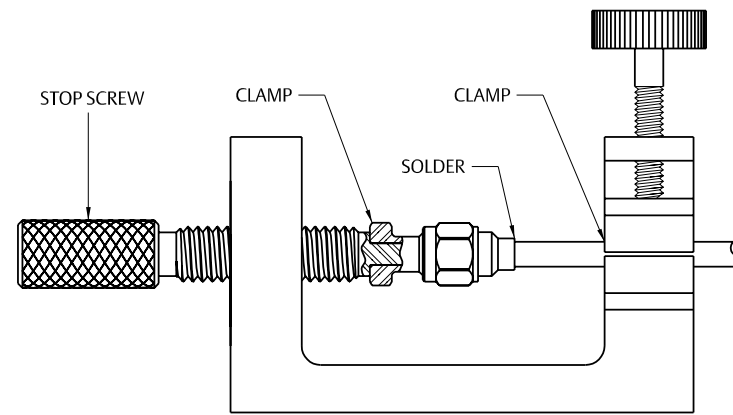
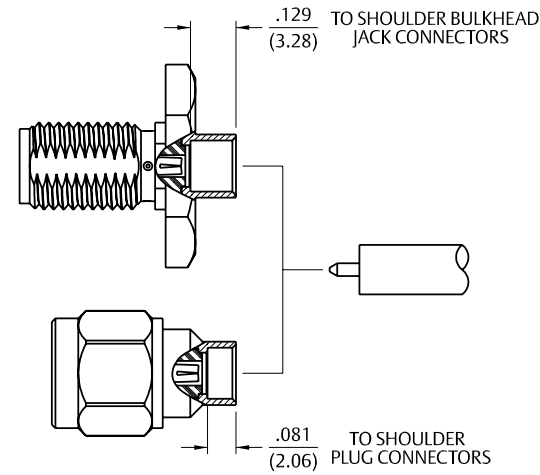

### SMA Crimp Type Right Angle Plugs for Flexible Cable

1. Identify connector parts. (3 piece parts)
2. Strip cable to dimensions shown. Do not nick braid or center conductor. When stripping LMR-100 low loss cable, remove foil back to where cable jacket is stripped. A wire stripper of correct size is recommended for this step. Twist stranded center conductor into tight bundle and tin (optional). Slide crimp sleeve onto cable as shown.
3. Flare braid and slide cable into body making certain that the cable insulation bottoms on center contact. Solder center conductor to contact through the rear access port. Use a minimum amount of solder for a full fillet joint. .020 (0.51) diameter solder is recommended.
4. Arrange braid uniformly around crimp stem. Slide crimp sleeve over braid and crimp securely using recommended crimp tool. Place expansion cap in access port and seat with .187 (4.75) diameter flat punch. Shrink heat shrink tubing over crimp sleeve if applicable.

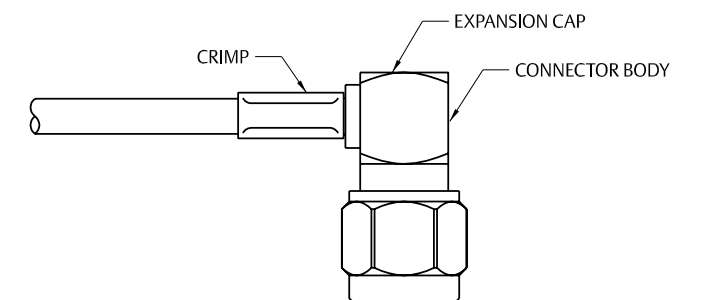
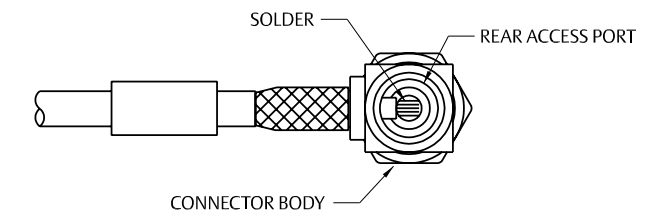
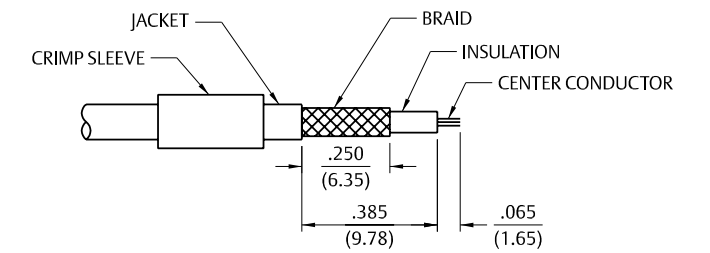
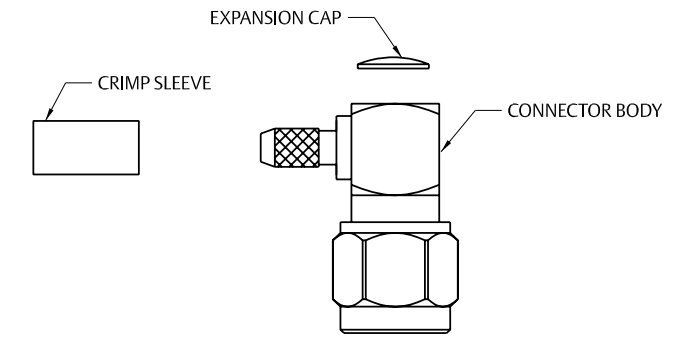



## SMA Crimp Type Right Angle Plugs for Flexible Cable (cont'd from last page)

Cable Group	Part No.	Crimp Hex
RG-316/U, 161, 174, 188; LMR-100	141-0403-102	.128 (3.25)
RG-316 DS, 188 DS	141-0404-112	.151 (3.83)
RG-58/U, 141, 303	141-0407-102	.213 (5.41)
RG-55/U, 142, 223, 400	141-0408-102	.213 (5.41)
RG-178/U, 196	142-0402-101 142-0402-106	.105 (2.67) .105 (2.67)
RG-316/U, 161, 174, 188; LMR-100	142-0403-101 142-0403-106	.128 (3.25) .128 (3.25)
RG-316 DS, 188 DS	142-0404-101 142-0404-106	.151 (3.83) .151 (3.83)
RG-58/U, 141, 303	142-0407-101 142-0407-106	.213 (5.41) .213 (5.41)
RG-55/U, 142, 223, 400	142-0408-101 142-0408-106	.213 (5.41) .213 (5.41)
RG-179/U, 187	142-0433-101 142-0433-106	.128 (3.25) .128 (3.25)
RG-316/U, 161, 174, 188; LMR-100	142-4403-101 142-4403-106	.128 (3.25) .128 (3.25)
RG-316 DS, 188 DS	142-4404-101 142-4404-106	.151 (3.83) .151 (3.83)
RG-58/U, 141, 303	142-4407-101 142-4407-106	.213 (5.41) .213 (5.41)
RG-55/U, 142, 223, 400	142-4408-101 142-4408-106	.213 (5.41) .213 (5.41)
RG-316/U, 161, 174, 188; LMR-100	142-5403-101 142-5403-106	.128 (3.25) .128 (3.25)
RG-316 DS, 188 DS	142-5404-101 142-5404-106	.151 (3.83) .151 (3.83)
RG-58/U, 141, 303	142-5407-101 142-5407-106	.213 (5.41) .213 (5.41)
RG-55/U, 142, 223, 400	142-5408-101 142-5408-106	.213 (5.41) .213 (5.41)
RG-316/U, 188, 174	142-9403-101	.128 (3.25)
RG-316 DS, 188 DS	142-9404-101	.151 (3.83)
RG-58/U, 141	142-9407-101	.213 (5.41)

## SMA Crimp Type Straight Plugs, Straight Jacks, and Straight Bulkhead Jacks for Flexible Cable

1. Identify connector parts. (6 piece parts – except bulkhead)
2. Strip cable to dimensions shown. Do not nick braid or center conductor. A wire stripper of correct size is recommended for this step. Twist stranded center conductor into tight bundle and tin (optional). Slide crimp sleeve, nut and heat shrink tubing (as applicable) onto cable as shown.
3. Flare braid and slide cable into crimp stem. Place rear insulator and center contact over center conductor and position as shown for different cable sizes. Solder center conductor to contact through the solder hole. Solder must not be allowed to gather and run on outside of contact. Use a minimum amount of solder for a good joint. .020 (0.51) diameter solder is recommended.
4. Arrange braid uniformly around crimp stem. Slide crimp sleeve over braid and crimp securely using recommended crimp tool. Slide center contact assembly into connector body. Thread coupling nut onto body and tighten to 10 in.-lb. torque. Slide heat shrink forward and shrink (as applicable).

Cable Group	Part No.	Crimp Hex
RG-178/U, 196	142-0302-401 142-0302-406	.105 (2.67) .105 (2.67)
RG-316/U, 161, 174, 188	142-0303-401 142-0303-406	.128 (3.25) .128 (3.25)
RG-316 DS, 188 DS	142-0304-401 142-0304-406	.151 (3.83) .151 (3.83)
RG-58/U, 141, 303	142-0307-401 142-0307-406	.213 (5.41) .213 (5.41)
RG-55/U, 142, 223, 400	142-0308-401 142-0308-406	.213 (5.41) .213 (5.41)
RG-316/U, 161, 174, 188	142-0403-001 142-0403-006	.128 (3.25) .128 (3.25)

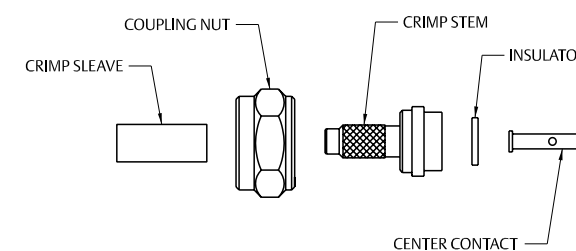
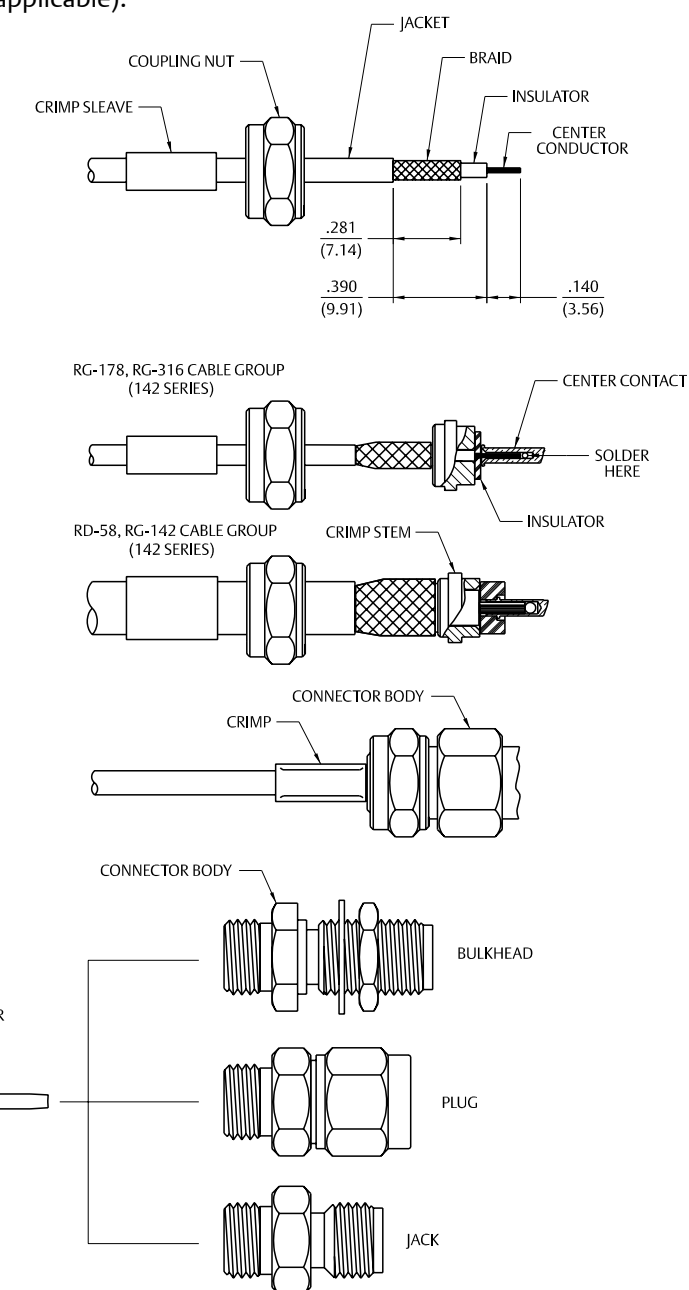

For more information, please contact customer service at (507) 833-8822 or (800) 247-8256 • [www.EmersonConnectivity.com](http://www.EmersonConnectivity.com)

Illustrations are shown in inches (millimeters).



## SMA High Frequency End Launch Connectors PC Mounting Instructions

High frequency end launch performance is dependent upon proper mounting. The following factors must be controlled for optimum performance:

- The connector should fit tightly against the circuit board edge, avoid gaps.
- The center contact pin must lie parallel and flat against the circuit board, avoid gaps.
- The contact pin should be centered on the circuit board signal trace.
- Use a minimal amount of solder between the contact pin and signal trace. Do not allow excess solder to build up or flow down the trace.
- Clean all excess flux and other residue from the launch area, especially between the trace and ground.

The basic steps required to mount the end launch connector to the circuit board are as follows:

- Fixture 140-0000-973 should be used as an aid during manual soldering. The fixture protects the connector from damage during clamping and also maintains the proper location of the connector's insulator and contact. To use the fixture, thread the coupling nut on the mating end of the connector and hand tighten. This mounting assembly can now be held in a vice or similar clamping device, as shown in Figure 1.
- Position connector on the circuit board, making sure the contact pin is aligned with the center of the signal trace as shown in Figure 2. Make sure that the connector legs and contact pin are held flush against the top of the circuit board, keeping the axis of the connector parallel to the plane of the circuit board, as shown in Figure 3.
- A small amount of Teflon® insulation projects from rear mating plane of the connector, which acts as a seal when soldering the center conductor pin to the trace. Clamp the connector tightly against the edge of the board. This action compresses the insulator seal against the board edge. This effectively creates a barrier between the inner and outer conductors, preventing the bridging of solder.
- While ensuring the connector is held in the correct position, solder the ground legs and/or ground posts to the top and bottom of the board prior to bonding the center pin to the trace.
- Once the connector body is properly grounded to the board, the center contact pin can be bonded to the trace by using a minimal amount of solder as shown in Figure 4. It is important that solder flows along the length of the exposed pin, creating a good electrical and mechanical connection. Remove any excess solder that is not required for a solid joint.
- Clean all flux and other residues from the trace area between the signal side ground legs, as any flux present between the signal trace and ground will affect performance. The completed mounting assembly should look similar to the one shown in Figure 5.



Figure 1



Figure 2



Figure 3



Figure 4



Figure 5

The **End Launch** connector is attached to the circuit board by inserting the board edge between the legs and soldering the legs and center conductor to the pads on the board. For optimum high frequency performance, the connector to circuit board transition must be adjusted for low VSWR. To compensate for the transition from coax to microstrip, trace widths "A" and "B" must be adjusted based on circuit board thickness. When properly adjusted, this technique yields a low VSWR over a wide bandwidth.

The tabulated dimensions "A", "B", "C", "D", and "E" were determined experimentally to achieve low VSWR (typically less than 1.5 up to 18 GHz). The circuit board uses connectors for these tests that are double-sided FR4 with 1 oz. copper on both sides. The copper was left on the bottom of the board to create a ground plane for the 50 Ohm microstrip structure. While not all inclusive, these dimensions are given as reference information for selected SMA End Launch connectors. Further adjustments may be necessary depending upon the application. All dimensions are in inches (millimeters).

Part No.	Base Width	Board Thickness	"A"	"B"	"C"	"D"	"E"
142-0791-801	.375	.062 (1.57)	.073	.073	.250	.440	.200
142-0791-811	.375	.042 (1.07)	.103	.103	.250	.440	.200
142-0791-821	.375	.062 (1.57)	.083	.083	.250	.440	.200
142-1701-821	.375	.062 (1.57)	See Figure 2 below for attachment dimensions				
142-1701-831	.375	.059 (1.50)	See Figure 2 below for attachment dimensions				

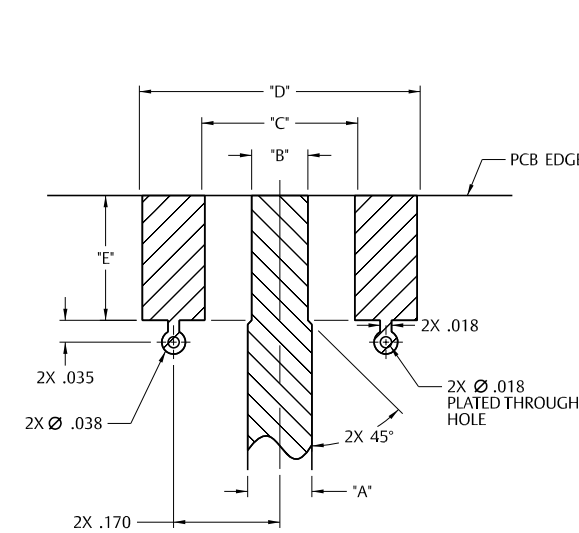

Figure 1

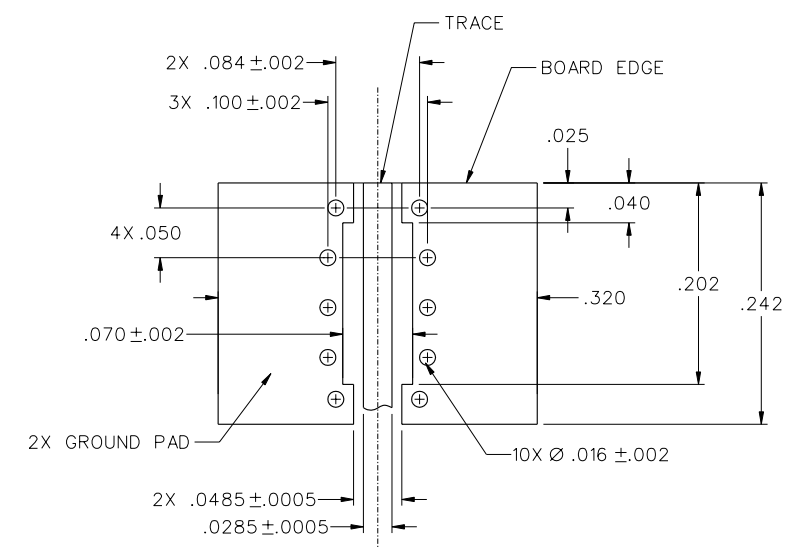

Figure 2

### Reference dimensions for 50 Ohm grounded coplanar waveguide using Rogers Corporation RO4003C™ high frequency substrate laminate \*

Holes Part No.	GCPW 50Ω Impedance Reference Dimensions*				Mounting and Via		
	Substrate Thickness	Conductor Thickness	Trace Width "A"	Ground Gaps "B"	Fig	"C"	"D"
142-0761-801	.0080 (0.203)	.0014 (0.036)	.0155 (0.394)	.0100 (0.254)	1	.066 (1.68)	.096 (2.44)
142-0761-811	.0080 (0.203)	.0014 (0.036)	.0155 (0.394)	.0100 (0.254)	1	.066 (1.68)	.096 (2.44)
142-0761-821	.0160 (0.406)	.0014 (0.036)	.0285 (0.724)	.0100 (0.254)	1	.084 (2.13)	.113 (2.87)
142-0761-831	.0160 (0.406)	.0014 (0.036)	.0285 (0.724)	.0100 (0.254)	1	.084 (2.13)	.113 (2.87)
142-0761-841	.0080 (0.203)	.0014 (0.036)	.0155 (0.394)	.0100 (0.254)	2	.066 (1.68)	
142-0761-851	.0080 (0.203)	.0014 (0.036)	.0155 (0.394)	.0100 (0.254)	2	.066 (1.68)	
142-0761-861	.0160 (0.406)	.0014 (0.036)	.0285 (0.724)	.0100 (0.254)	2	.084 (2.13)	
142-0761-871	.0160 (0.406)	.0014 (0.036)	.0285 (0.724)	.0100 (0.254)	2	.084 (2.13)	
142-0761-881	.0080 (0.203)	.0014 (0.036)	.0155 (0.394)	.0100 (0.254)	1	.066 (1.68)	.096 (2.44)
142-0761-891	.0080 (0.203)	.0014 (0.036)	.0155 (0.394)	.0100 (0.254)	2	.066 (1.68)	
142-0771-821	.0160 (0.406)	.0014 (0.036)	.0285 (0.724)	.0100 (0.254)	1	.084 (2.13)	.113 (2.87)
142-0771-831	.0160 (0.406)	.0014 (0.036)	.0285 (0.724)	.0100 (0.254)	2	.084 (2.13)	

\* These calculated dimensions assume a quasi-static mode of propagation, but dispersion does exist for coplanar waveguide. The characteristic impedance and effective dielectric constant may increase slightly for X-band and higher frequencies, unless very small ground to ground gap spacing is used.

It is assumed the conductors have rectangular cross-sections. The etching process used in circuit board fabrication actually produces trapezoidal shapes. Therefore, the GCPW impedance may increase somewhere between that of a perfect rectangular conductor and a theoretical zero thickness conductor.



Figure 1

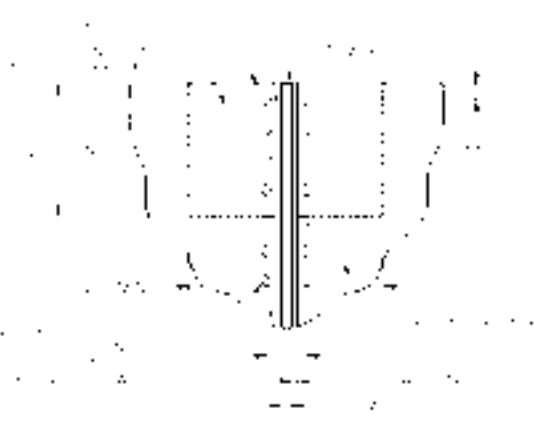

Figure 2

### Right Angle SMA Low Loss Diameter .195, .200 and .240

1. Identify connector parts. (3 piece parts)
2. Strip cable to dimensions shown. Do not nick braid, foil or center conductor. Cut foil flush with dielectric, do not remove foil. Make sure that dielectric is clean and free from all particles. Tin center conductor, keeping solder amount to a minimum. Slide crimp sleeve onto jacket of cable.
3. Flare braid and slide body assembly over foil and dielectric, then under braid. Make sure cable center conductor is contained within connector contact, but do not allow foil and dielectric to enter body access port. Solder center conductor to contact through the rear access port. Use a minimum amount of solder for a full fillet joint. .020 (0.51) Diameter solder is recommended.
4. Arrange braid uniformly around crimp stem. Slide crimp sleeve forward and crimp using Johnson hand crimp tool 141-0000-913 and recommended crimp die hex. Place expansion cap in access port and seat with recommended Diameter flat punch.

Low Loss Diameter	"A"	Crimp Die Hex	Flat Punch Diameter
0.195	.110 (2.79)	.213 (5.41) hex	.187 (4.75)
0.200	.110 (2.79)	.213 (5.41) hex	.187 (4.75)
0.240	.135 (3.43)	.255 (6.48) hex	.242 (6.15)

Cable Group	Part No.	Crimp Hex
LMR-195	142-0407-101	.213 (5.41)
	142-0407-106	.213 (5.41)
LMR-200	142-4439-101	.213 (5.41)
	142-4439-106	.213 (5.41)
LMR-240	142-0435-101	.255 (6.48)
	142-0435-106	.255 (6.48)
LMR-195	142-5407-101	.213 (5.41)
	142-5407-106	.213 (5.41)
LMR-200	142-0439-101	.213 (5.41)
	142-0439-106	.213 (5.41)
LMR-240	142-5435-101	.255 (6.48)
	142-5435-106	.255 (6.48)
LMR-195	142-4407-101	.213 (5.41)
	142-4407-106	.213 (5.41)
LMR-200	142-5439-101	.213 (5.41)
	142-5439-106	.213 (5.41)
LMR-240	142-4435-101	.255 (6.48)
	142-4435-106	.255 (6.48)

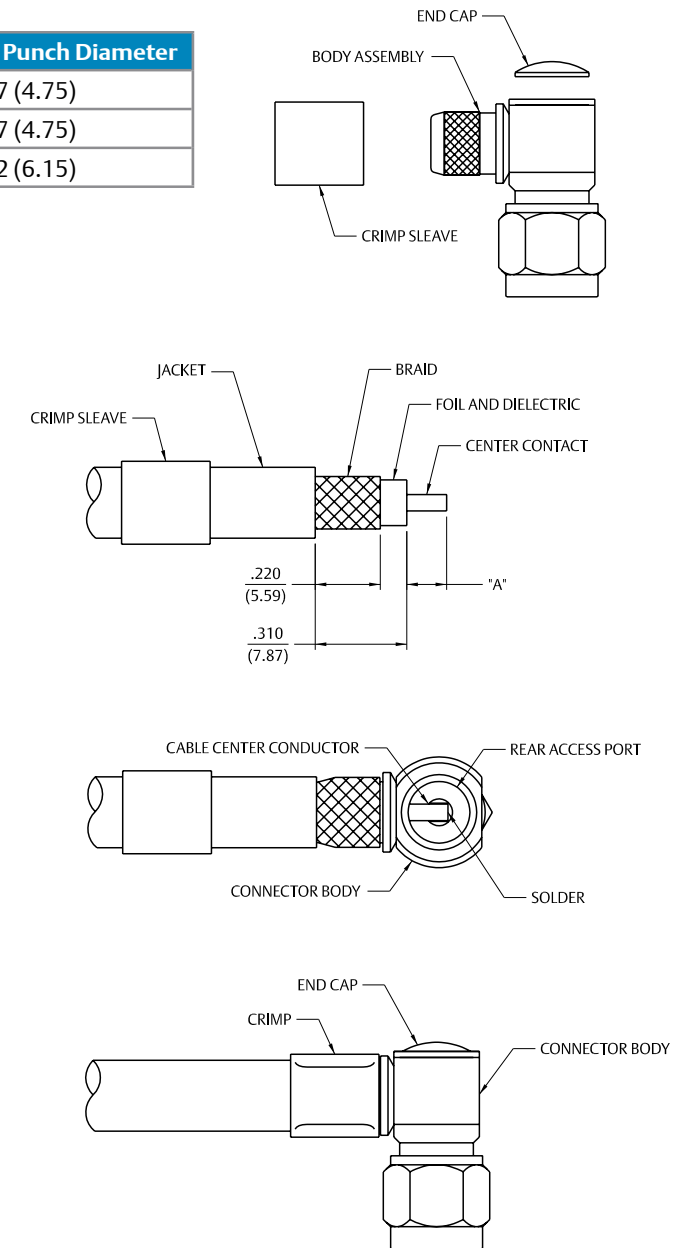

## SMA Clamp Type Straight Plugs, Straight Jacks, and Straight Bulkhead Jacks for Flexible Cable

1. Identify connector parts. (6 piece parts – except bulkhead)
2. Strip cable to dimensions shown. Do not nick braid or center conductor. A wire stripper of correct size is recommended for this step. Twist stranded center conductor into tight bundle and tin (optional). Slide clamp nut and clamp cone onto cable as shown. Clamp cone must be oriented as shown for each size of cable. The RG-58/142 clamp cone slides over braid and against jacket.
3. Flare braid and slide cable into clamp stem. Place rear insulator and center contact over center conductor and position as shown for different cable sizes. Solder center conductor to contact through the solder hole. Solder must not be allowed to gather and run on outside of contact. Use a minimum amount of solder for a good joint. .020 (0.51) diameter solder is recommended.
4. Arrange braid uniformly around clamp stem. Slide center contact assembly into body. Slide clamp nut against clamp cone and braid and tighten to 10 in.-lb. torque.

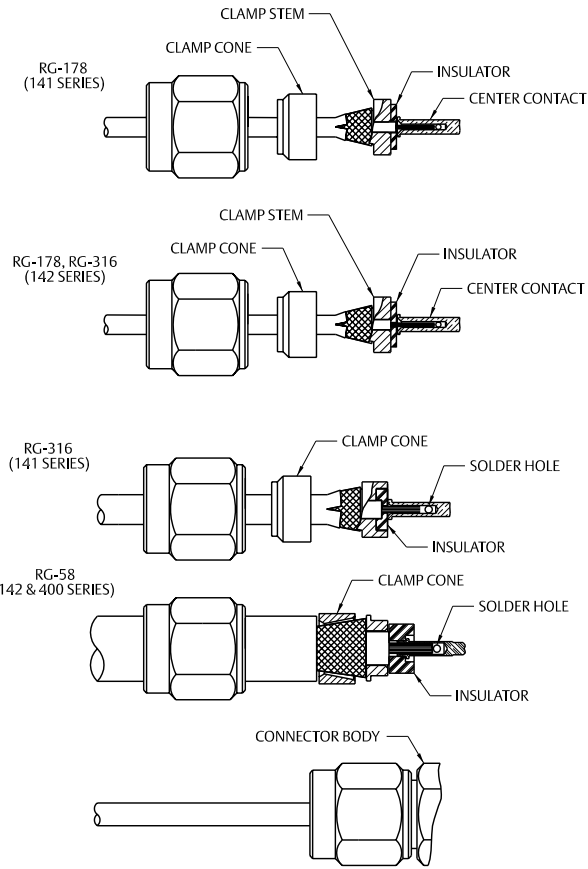

Cable Group	Part No.	"A"	"B"	"C"
RG-178/U, 196	142-0202-011/016	.133 (3.38)	.053 (1.35)	.085 (2.16)
RG-161/U, 174,188, 316	142-0203-011/016	.133 (3.38)	.053 (1.35)	.085 (2.16)
RG-58/U, 141, 303	142-0207-011/016	.225 (5.72)	.145 (3.68)	NONE
RG-142, 223, 55, 400	142-0207-011/016	.285 (7.24)	.165 (4.19)	NONE
RG-178/U, 196	142-0102-401/406	.133 (3.38)	.053 (1.35)	.085 (2.16)
RG-161/U, 174,188, 316	142-0103-401/406	.133 (3.38)	.053 (1.35)	.085 (2.16)
RG-58/U, 141, 303	142-0107-401/406	.225 (5.72)	.145 (3.68)	NONE
RG-142, 223, 55, 400	142-0107-401/406	.285 (7.24)	.165 (4.19)	NONE

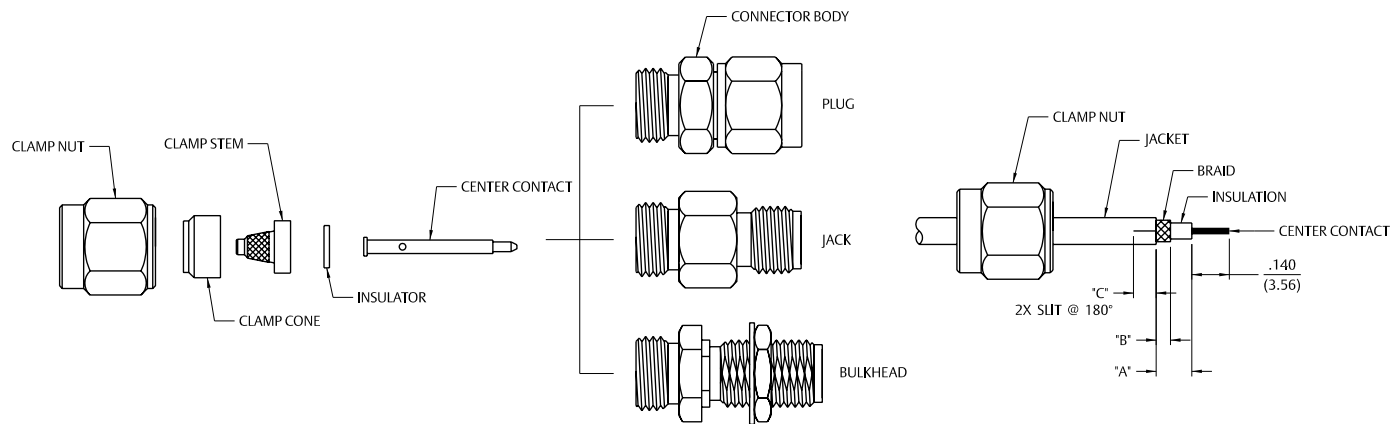

## SMA Clamp Type Right Angle Plugs for Flexible Cable

1. Identify connector parts. (4 piece parts)
2. Strip cable to dimensions shown. Do not nick braid or center conductor. A wire stripper of correct size is recommended for this step. Twist stranded center conductor into tight bundle and tin (optional). Slide clamp nut and clamp cone onto cable as shown. Clamp cone must be oriented as shown for each size of cable. The RG-58/142 clamp cone slides over braid and against jacket.
3. Flare braid and slide cable into body making certain that the cable insulation bottoms on center contact. Stepped down diameter of stem must slide under braid and jacket. Arrange braid uniformly around crimp stem. Slide clamp nut against clamp cone and braid and tighten to 10 in.-lb. torque.
4. Solder center conductor to contact through the rear access port. Use a minimum amount of solder for a full fillet joint. .020 (0.51) diameter solder is recommended. Place expansion cap in access port and seat with .187 (4.75) diameter flat punch.

Cable Group	Part No.	"A"	"B"	"C"
RG-178/U, 196	142-0202-101 142-0202-106	.280 (7.11) .280 (7.11)	.053 (1.35) .053 (1.35)	.085 (2.16) .085 (2.16)
RG-316/U, 161, 174, 188	142-0203-101 142-0203-106	.280 (7.11) .280 (7.11)	.053 (1.35) .053 (1.35)	.085 (2.16) .085 (2.16)
RG-58/U 141, 303	142-0207-101 142-0207-106	.395 (10.03) .395 (10.03)	.160 (4.06) .160 (4.06)	NONE NONE
RG-55/U, 142, 233, 400	142-0207-101 142-0207-106	.420 (10.67) .420 (10.67)	.180 (4.57) .180 (4.57)	NONE NONE

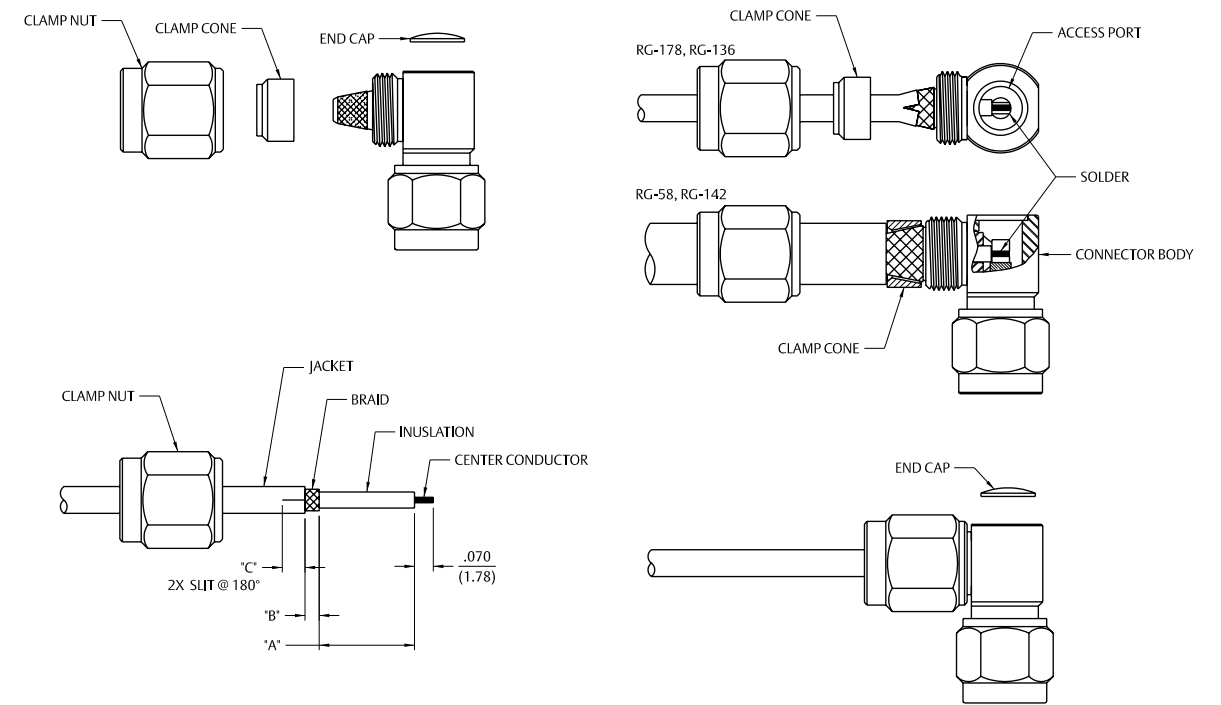

### SMB 3-Piece Straight Plugs

1. Identify connector parts. (3 piece parts): Crimp sleeve, body assembly and contact
2. Strip cable to dimensions shown. Do not nick braid or center conductor. Tin center conductor if contact will be solder attached. Do not tin center conductor if contact is to be crimp attached. Slide heat shrink (as applicable) and crimp sleeve onto jacket of cable.
3. Assemble contact onto cable as shown.  
**Solder Attachment:** Solder contact to center conductor through solder hole using .015 (0.38) diameter solder. Use a minimum amount of solder for a good joint.  
**Crimp Attachment:** A miniature 8 indent crimp tool 140-0000-970 is recommended. Crimp location should be centered between end of contact and X-hole using positioner 140-0000-971. Crimp attachment to solid center conductor cables is not recommended.
4. Flare braid and slide body assembly over contact and under braid. Then seat body assembly firmly onto contact. The cable may have to be held in a clamping fixture. Arrange braid uniformly around crimp stem. Slide crimp sleeve forward and crimp using recommended crimp tool. Slide heat shrink forward and shrink (as applicable).

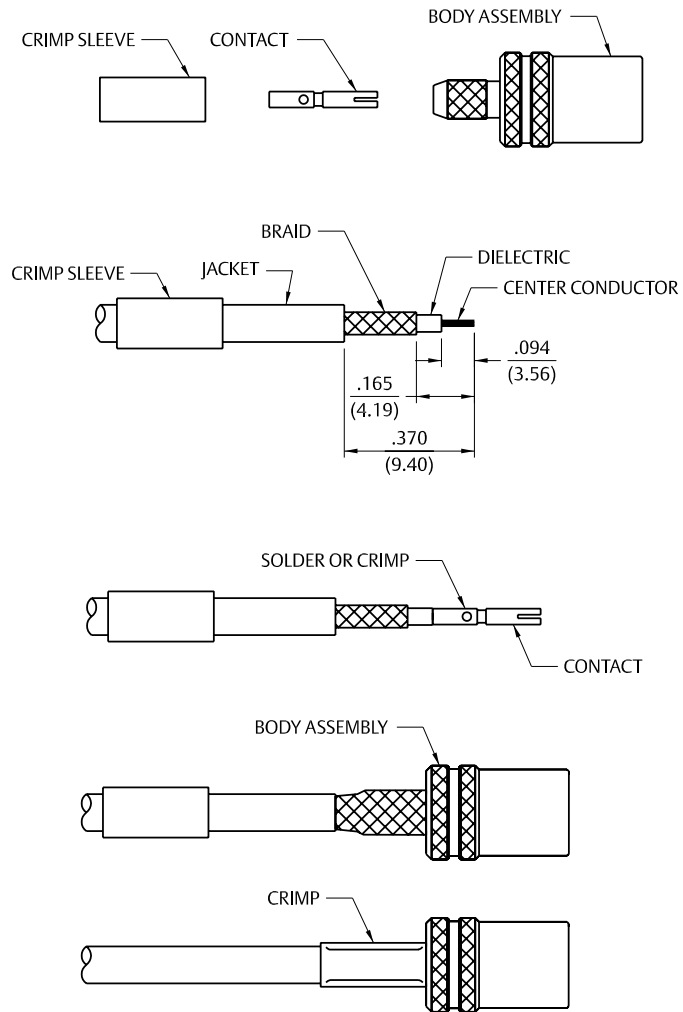

Cable Group	Part No.	Crimp Hex
RG-316/U, 161, 174, 179, 187, 188	131-3403-021/026	.128 (3.25)
RG-316 DS, 188 DS, 179 DS	131-3404-021/026	.151 (3.83)
RG-58/U, 141, 303	131-3407-011/016	.213 (5.41)
RG-179/U, 187	131-8433-001/006	.128 (3.25)
RG-179 DS, 187 DS	131-8434-001/006	.151 (3.83)
Belden 735A	131-8445-011/016	.178 (4.52)
RG-316/U, 188, 174, 179, 187	131-9403-021	.128 (3.25)
RG-316 DS, 188 DS, 179 DS, 187 DS	131-9404-021	.151 (3.83)

### SMB/SMC Solder Type Straight Plugs and Jacks for Semi-Rigid Cable

1. Identify connector parts. (2 piece parts – except bulkhead)
2. Strip cable to dimensions shown. Do not nick center conductor. Slide cover sleeve onto cable as shown.
3. Insert cable into body making certain that the cable insulation bottoms on center contact. Solder center conductor to contact through the side access ports and hole in center contact. Use a minimum amount of solder for a good joint. .020 (0.51) diameter solder is recommended.
4. Slide cover sleeve over access ports and solder body to cable and cover sleeve to body. Use a minimum amount of heat to minimize cable insulation movement.

Cable Group	Part No.	"A"
RG-405/U (.086 Semi-Rigid)	131-3593-401/406	.025 (0.64)
	131-3693-001/016	.025 (0.64)
RG-402/U (.141 Semi-Rigid)	131-3694-401/406	.050 (1.27)
RG-405/U (.086 Semi-Rigid)	131-6593-401/406	.025 (0.64)

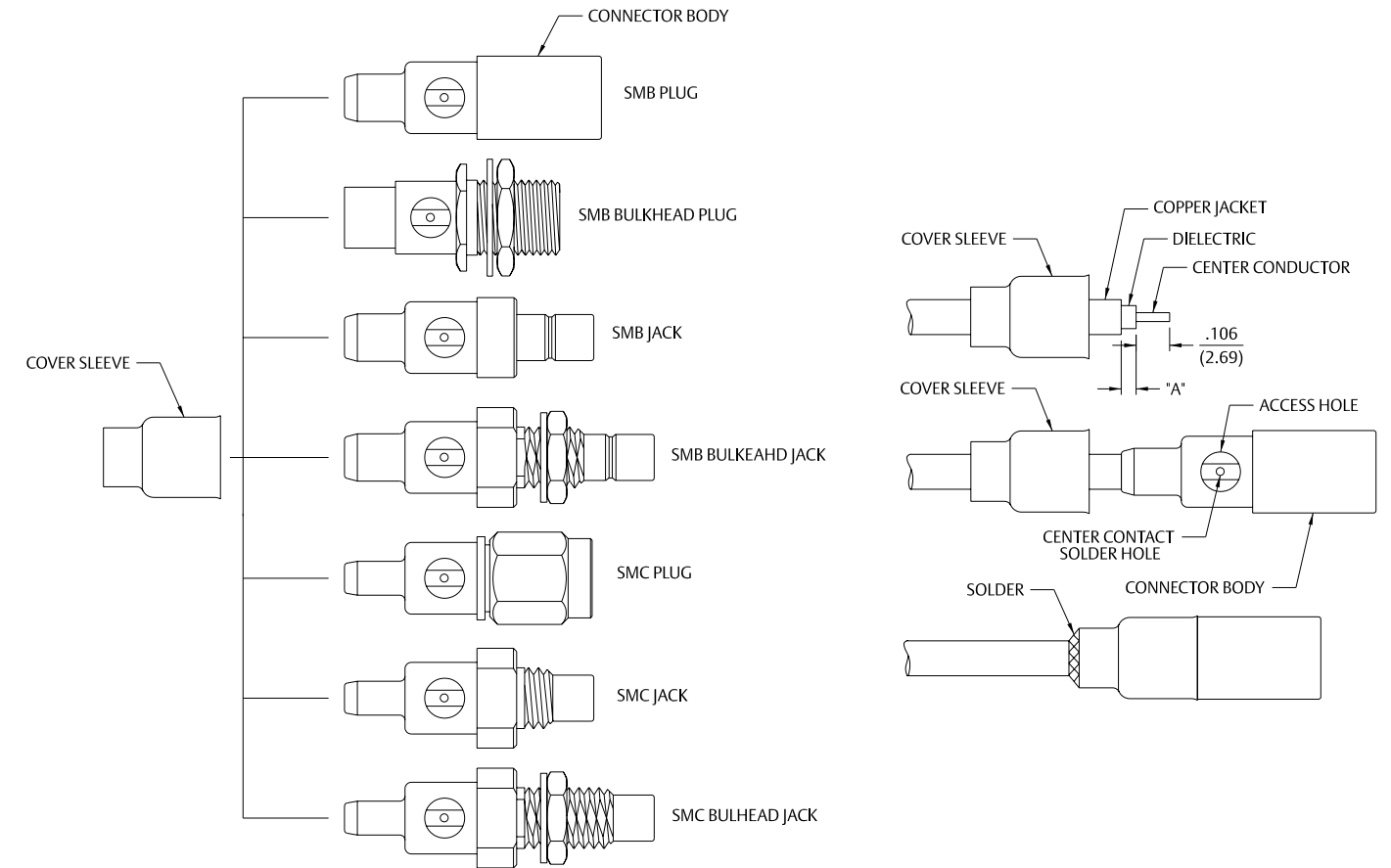

### SMB/SMC Solder Type Right Angle Plugs for Semi-Rigid Cable

1. Identify connector parts. (2 piece parts – except diecast)
2. Strip cable to dimensions shown. Do not nick center conductor.
3. Insert cable into body making certain that the cable insulation bottoms on center contact. Solder center conductor to contact through the rear and side access ports. Use a minimum amount of solder for a good joint. .020 (0.51) diameter solder is recommended.
4. Solder body to cable. Use a minimum amount of heat to minimize cable insulation movement. Place expansion cap in access port and set with .125 (3.17) diameter punch. Snap cover ring over side access port.

Cable Group	Part No.
RG-405/U (.086 Semi-Rigid)	131-1693-101 131-1693-116 131-3693-101 131-3693-116

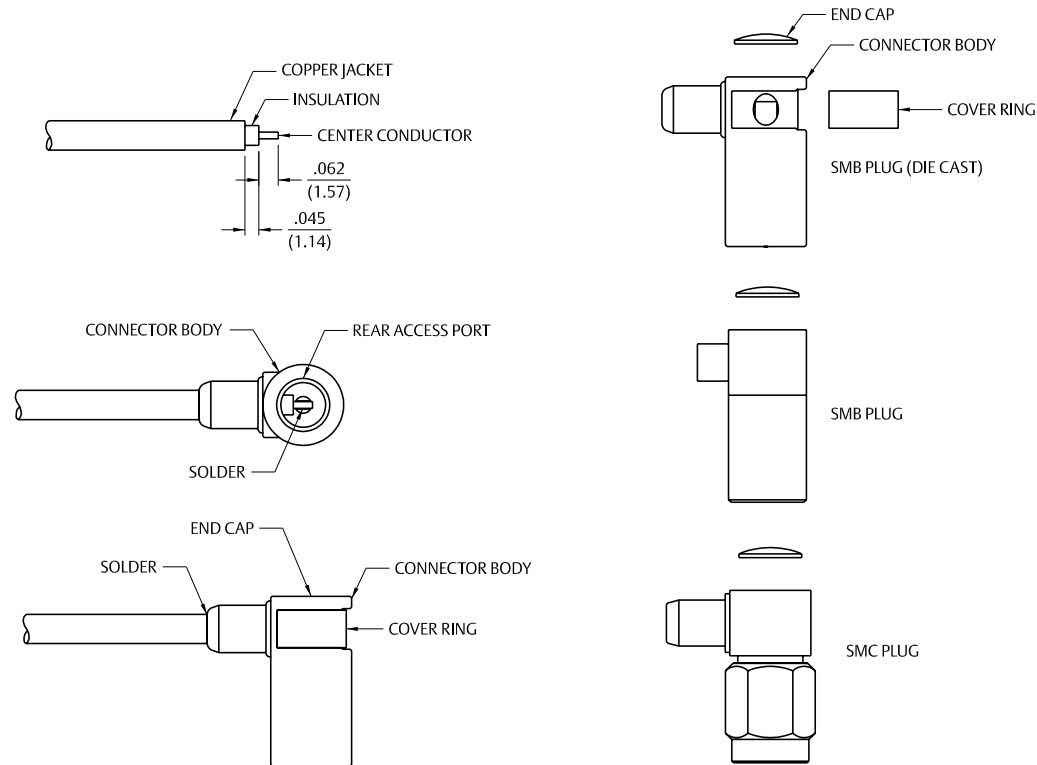

### SMB Straight Crimp Type Straight Plugs for Flexible Cable

1. Identify connector parts. (2 piece parts)
2. Strip cable to dimensions shown. Do not nick braid or center conductor. A wire stripper of correct size is recommended for this step. Twist stranded center conductor into tight bundle and tin. Slide crimp sleeve onto cable as shown.
3. Flare braid and slide cable into body making certain that the cable dielectric bottoms against center contact.
 

**Solder Attachment:** Solder center conductor to contact through the side access ports and hole in center contact. Use a minimum amount of solder for a full fillet joint. .020 (0.51) diameter solder is recommended.

**Crimp Attachment:** Crimp contacts with 141-0000-911 dieset in 144-0000-900 tool frame.

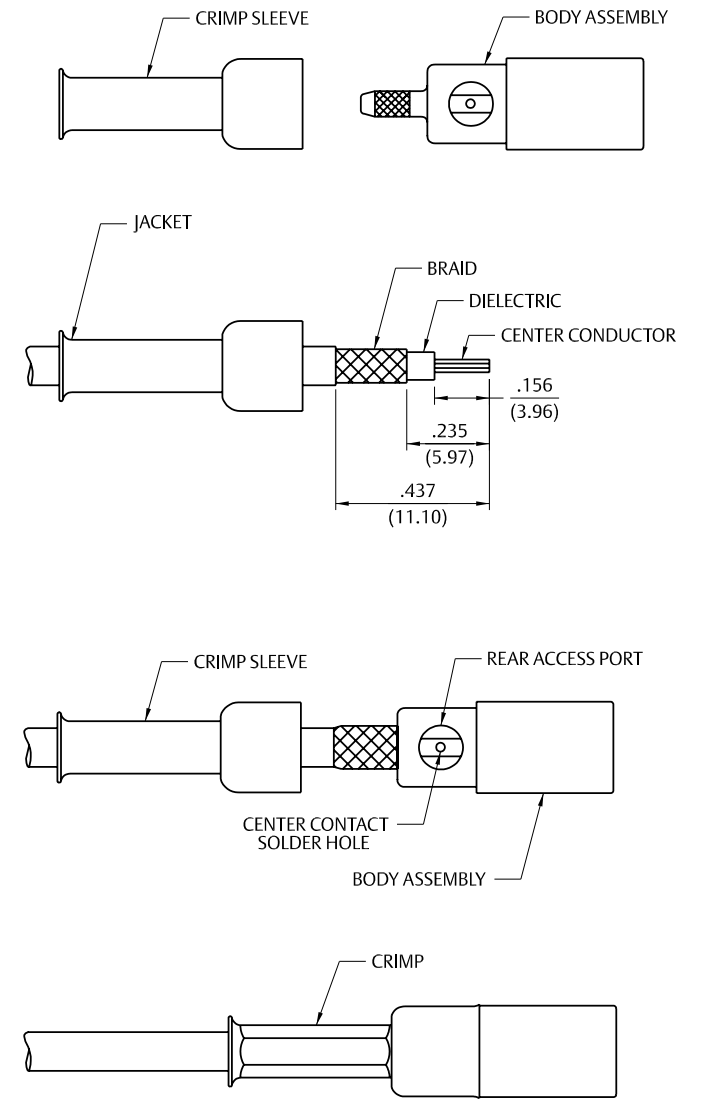

Cable Group	Part No.	Crimp Hex
RG-316/U, 188, 174, 179, 187	131-9403-001	.128 (3.25)
RG-316 DS, 188 DS, 179 DS, 187 DS	131-9404-001	.151 (3.83)

### SMB Right Angle Crimp Type Straight Plugs for Flexible Cable

1. Identify connector parts. (3 piece parts: crimp sleeve, body assembly and expansion cap.)
2. Strip cable to dimensions shown. Do not nick braid or center conductor. A wire stripper of correct size is recommended for this step. Twist stranded center conductor into tight bundle and tin (optional). Slide crimp sleeve onto cable as shown.
3. Flare braid and slide cable into body assembly making certain that the cable insulation bottoms on center contact. Arrange braid uniformly around crimp stem of body assembly. Slide crimp sleeve over braid and crimp securely using recommended crimp tool.
4. Solder center conductor to contact through the rear and side access ports. Use a minimum amount of solder for a good joint. .020 (0.51) diameter solder is recommended. Place expansion cap in access port and seat with a .125 (3.17) diameter flat punch. Snap cover ring over side access port.

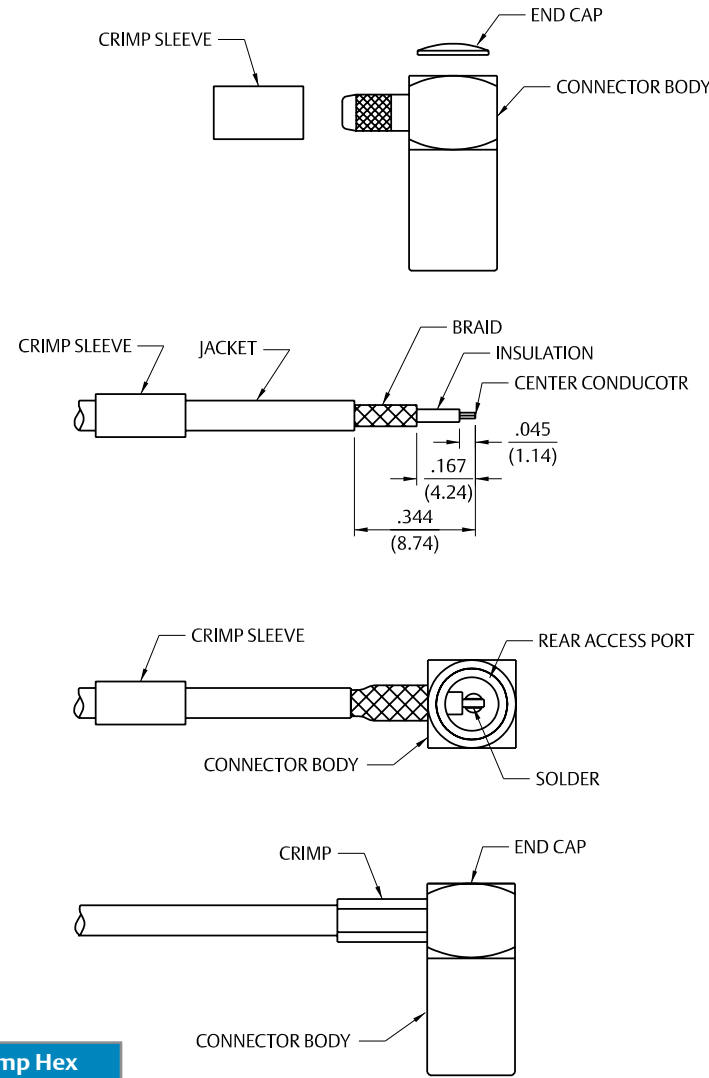

Cable Group	Part No.	Crimp Hex
RG-316/U, 188, 174, 179, 187	131-9403-101 / -116	.128 (3.25)
RG-316 DS, 188 DS, 179 DS, 187 DS	131-9404-101 / -116	.151 (3.83)

### SMB/SMC/Mini-75Ohm SMB (2-Piece) Crimp Type Straight Plugs, Jacks and Bulkhead Jacks for Flexible Cable

1. Identify connector parts. (2 piece parts – except bulkhead)
2. Strip cable to dimensions shown. Do not nick braid or center conductor. A wire stripper of correct size is recommended for this step. Twist stranded center conductor into tight bundle and tin. Slide crimp sleeve onto cable as shown.
3. Flare braid and slide cable into body making certain that the cable dielectric bottoms against center contact. **Solder Attachment:** Solder center conductor to contact through the side access ports and hole in center contact. Use a minimum amount of solder for a full fillet joint. .020 (0.51) diameter solder is recommended. **Crimp Attachment:** Crimp applicable 50 Ohm connector contacts with 141-0000-911 dieiset in 144-0000-900 tool frame. Crimp 75 Ohm connector contacts with 141-0000-924 dieiset in 144-0000-900 tool frame. Crimp attachment to solid center conductor cables is not recommended.

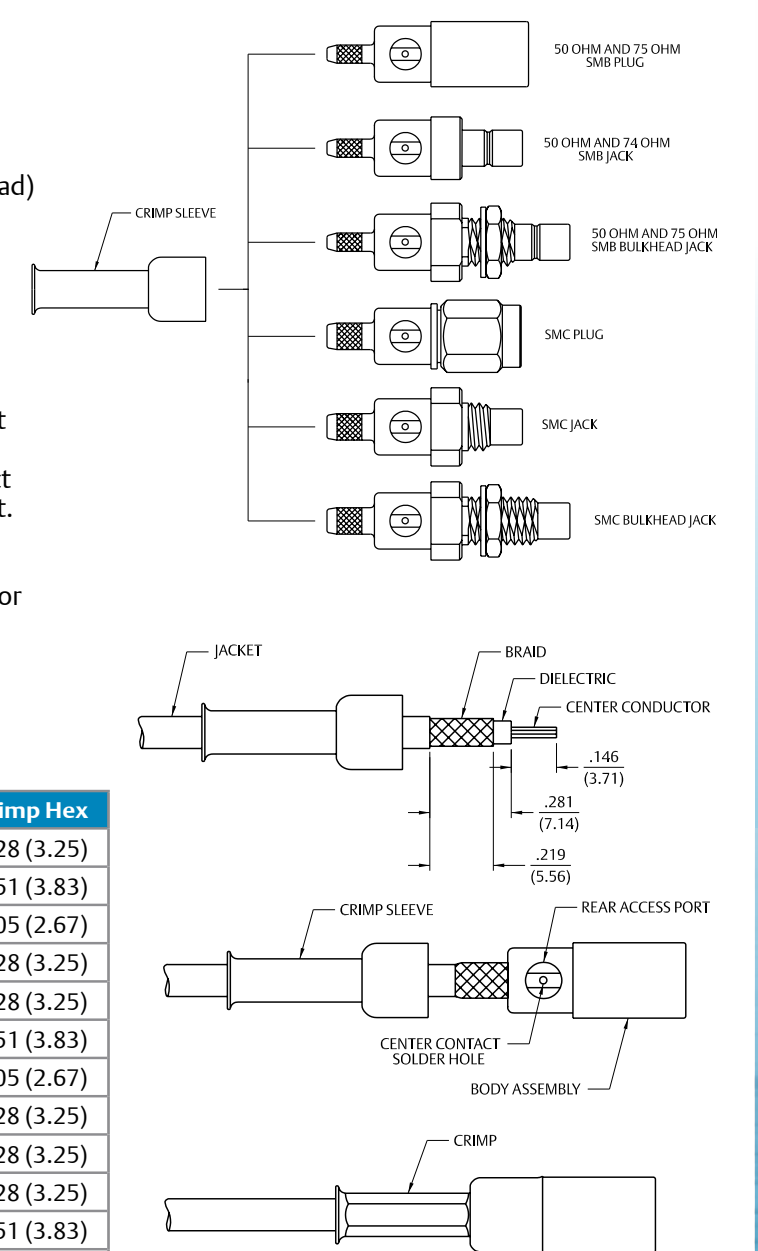

Cable Group	Part No.	Crimp Hex
RG-316/U, 161, 174, 179, 187, 188	131-1403-001/016	.128 (3.25)
RG-316 DS, 188 DS, 179 DS	131-1404-001/016	.151 (3.83)
RG-178/U, 196	131-3302-001/006	.105 (2.67)
RG-316/U, 161, 174, 179, 187, 188	131-3303-001/006	.128 (3.25)
RG-179 DS, 187 DS, 188 DS, 316 DS	131-3304-401/406	.151 (3.83)
RG-178/U, 196	131-3402-001/016	.105 (2.67)
RG-316/U, 161, 174, 179, 187, 188	131-3403-001/016	.128 (3.25)
RG-179 DS, 187 DS, 188 DS, 316 DS	131-3404-001/016	.151 (3.83)
RG-58/U, 141, 303	131-3407-001/006	.213 (5.41)
RG-316/U, 161, 174, 188	131-6303-401/406	.128 (3.25)
RG-316 DS, 188 DS	131-6304-401/406	.151 (3.83)
RG-179/U, 187	131-6333-401/406	.128 (3.25)
RG-316/U, 161, 174, 188	131-6403-001/006	.128 (3.25)
RG-316 DS, 188 DS	131-6404-001/006	.151 (3.83)
RG-179/U, 187	131-6433-001/006	.128 (3.25)
RG-179/U, 187, 316, 161, 174, 188	131-8303-401/406	.128 (3.25)
RG-179 DS, 187 DS, 188DS, 316DS	131-8304-401/406	.151 (3.83)
RG-179/U, 187, 316, 161, 174, 188	131-8403-001/006	.128 (3.25)
RG-179 DS, 187 DS, 188DS, 316DS	131-8404-001/006	.151 (3.83)
RG-59	131-8409-001/006	.255 (6.48)
BELDEN 735A	131-8445-001/006	.178 (4.52)

For more information, please contact customer service at (507) 833-8822 or (800) 247-8256 • www.EmersonConnectivity.com  
Illustrations are shown in inches (millimeters).

### SMB/SMC/Mini-75Ohm SMB Crimp Type Right Angle Plugs and Right Angle Bulkhead Jacks for Flexible Cable

1. Identify connector parts. (4 piece parts: crimp sleeve, body assembly, expansion cap and covering ring. Die cast body only.)
2. Strip cable to dimensions shown. Do not nick braid or center conductor. A wire stripper of correct size is recommended for this step. Twist stranded center conductor into tight bundle and tin (optional). Slide crimp sleeve onto cable as shown.
3. Flare braid and slide cable into body assembly making certain that the cable insulation bottoms out on center contact. Arrange braid uniformly around crimp stem of body assembly. Slide crimp sleeve over braid and crimp securely using recommended crimp tool.

4. Solder center conductor to contact through the rear and side access ports. Use a minimum amount of solder for a good joint. .020 (0.51) diameter solder is recommended. Place expansion cap in access port and seat with a .125 (3.17) diameter flat punch. Snap cover ring over side access port if applicable.

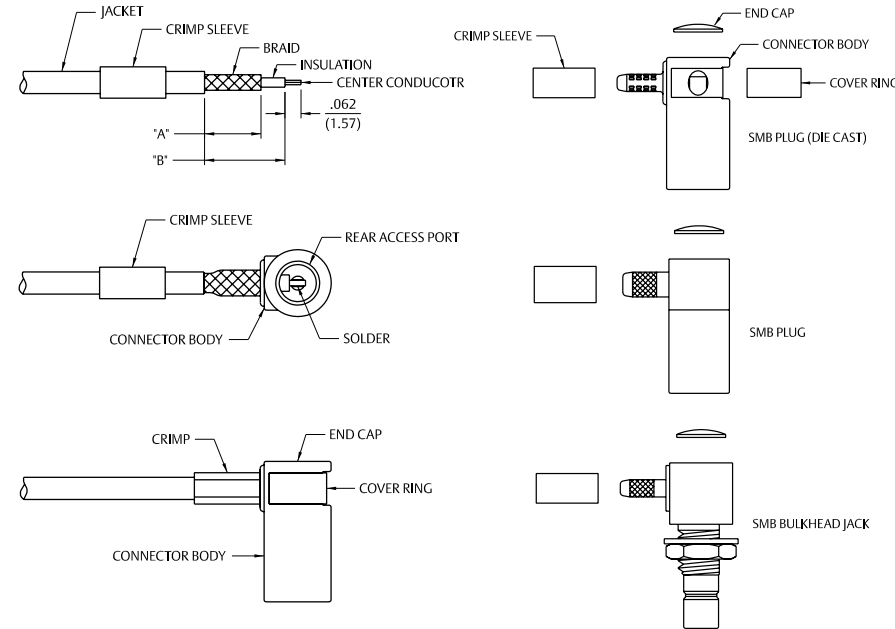

Cable Group	Part No.	"A"	"B"	Crimp Hex
RG-178/U, 196	131-1402-101/116	.219 (5.56)	.312 (7.92)	.105 (2.67)
RG-316/U, 161, 174, 179, 187, 188	131-1403-101/116	.219 (5.56)	.312 (7.92)	.128 (3.25)
RG-179 DS, 187 DS, 188 DS, 316 DS	131-1404-101/116	.219 (5.56)	.312 (7.92)	.151 (3.83)
RG-316/U, 161, 174, 179, 187, 188	131-3303-501/506	.219 (5.56)	.312 (7.92)	.128 (3.25)
RG-179 DS, 187 DS, 188 DS, 316 DS	131-3304-501/506	.219 (5.56)	.312 (7.92)	.151 (3.83)
RG-178/U, 196	131-3402-101/116	.177 (4.50)	.289 (7.34)	.105 (2.67)
RG-316/U, 161, 174, 179, 187, 188	131-3403-101/116	.177 (4.50)	.289 (7.34)	.128 (3.25)
RG-179 DS, 187 DS, 188 DS, 316 DS	131-3404-101/116	.177 (4.50)	.289 (7.34)	.151 (3.83)
RG-58/U, 141, 303	131-3407-101/106	.219 (5.56)	.289 (7.34)	.213 (5.41)
RG-316/U, 161, 174, 188	131-6403-101/106	.219 (5.56)	.312 (7.92)	.128 (3.25)
316 DS, 188 DS	131-6404-101/106	.219 (5.56)	.312 (7.92)	.151 (3.83)
RG-179/U, 187	131-6433-101/106	.219 (5.56)	.312 (7.92)	.151 (3.83)
RG-179/U, 187, 316, 161, 174, 188	131-8403-101/106	.177 (4.50)	.289 (7.34)	.128 (3.25)
161, 174, 188	131-8403-111/116	.219 (5.56)	.312 (7.92)	.128 (3.25)
RG-179 DS, 187 DS	131-8404-101/106	.177 (4.50)	.289 (7.34)	.151 (3.83)
316 DS, 188 DS	131-8404-111/116	.219 (5.56)	.312 (7.92)	.151 (3.83)
RG-59	131-8409-101/106	.219 (5.56)	.289 (7.34)	.255 (6.48)
BELDEN 735A	131-8445-101/106	.177 (4.50)	.289 (7.34)	.178 (4.52)
RG-316/U, 188, 174, 179, 187	131-9403-101/116	.177 (4.50)	.289 (7.34)	.128 (3.25)
RG-316 DS, 188 DS, 179 DS, 187 DS	131-9404-101/116	.177 (4.50)	.289 (7.34)	.151 (3.83)

### Type N Crimp Type Bulkhead Jack for Flexible Cable

1. Identify connector parts. (6 piece parts)
2. Strip cable to dimensions shown. Do not nick braid or center conductor. A wire stripper of correct size is recommended for this step. Twist stranded center conductor into a tight bundle and tin (optional). Slide crimp sleeve onto cable as shown.
3. Flare body and slide cable into crimp stem of rear body subassembly, until cable dielectric bottoms out on center contact. Solder center conductor to contact through the solder hole. Solder must not be allowed to gather and run on outside of contact. Use a minimum amount of solder for a good joint. .020 (0.51) diameter solder is recommended.
4. Arrange braid uniformly around crimp stem. Slide crimp sleeve over braid and crimp securely using recommended crimp tool. Slide insulator over center conductor and slide center contact assembly into connector body. Thread rear body subassembly into body and tighten securely (ref. 30 in-lbs torque.)

Cable Group	Part No.	Crimp Hex
RG-316/U, 161, 174, 188	134-0303-406	.160 (4.06)
RG-316 DS, 188 DS	134-0304-406	.160 (4.06)
RG-58/U, 141, 303	134-0307-406	.213 (5.41)
RG-55/U, 142, 223, 400	134-0308-406	.213 (5.41)

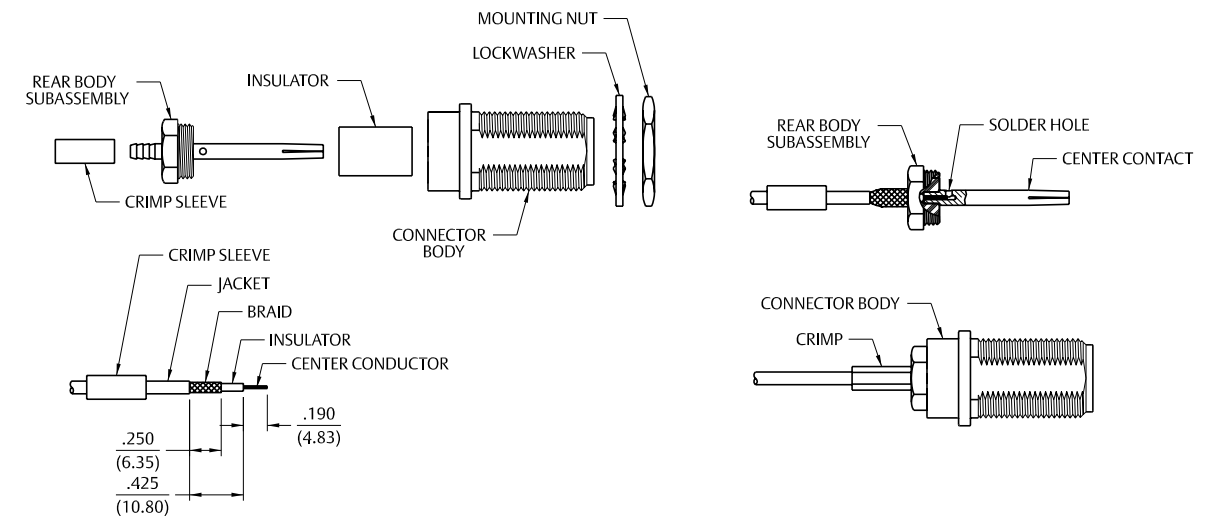



### Type N Straight Crimp Type Plugs for Flexible Cable

1. Identify connector parts. (3 piece parts – except bulkheads)
2. Strip cable to dimensions shown. Do not nick braid or center conductor. Tin center conductor if contact will be solder attached. Do not tin center conductor if contact is to be crimp attached. A wire stripper of correct size is recommended for this step. Slide heat shrink (as applicable) and crimp sleeve onto jacket of cable.
3. Assemble contact onto cable as shown.  
**Solder Attachment:** Solder contact to center conductor through hole using a minimum amount of solder for a good joint.  
**Crimp Attachment (where applicable):** Crimp contact to center conductor using recommended crimp hex.
4. Flare braid and slide body assembly over contact and under braid. Then seat body assembly firmly onto contact. The cable may have to be held in a clamping fixture. Arrange braid uniformly around crimp stem. Slide crimp sleeve forward and crimp using recommended crimp hex. Slide heat shrink forward and shrink (as applicable).

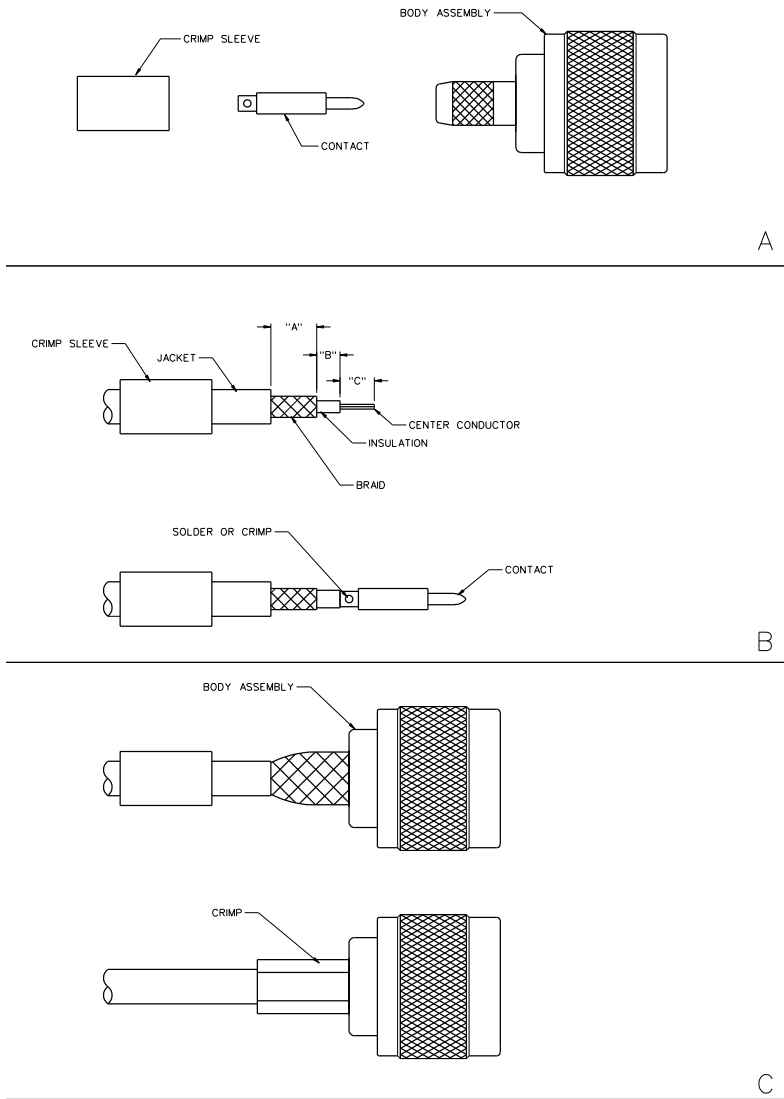

Part No.	Cable	Strip Dimensions			Crimp Sleeve Hex	Contact Crimp Hex	Recommended Crimp
		"A"	"B"	"C"			
CPN681	RG-58	.335 (8.50)	.079 (2.00)	.157 (4.00)	.215 (5.46)	.065 (1.65)	24-8858P
CPN6813	RG-142	.335 (8.50)	.079 (2.00)	.157 (4.00)	.215 (5.46)	.065 (1.65)	24-8858P
CPN688	RG-8, 213	.354 (9.00)	.138 (3.50)	.157 (4.00)	.429 (10.90)	.100 (2.54)	24-313
138-4408-007	RG-55/U, 142, 223, 400	.301 (7.65)	.140 (3.56)		.213 (5.41)	.068 (1.73)	.113 (2.87)
138-4449-007	LMR-400, BELDEN 9913	.385 (9.78)	.170 (4.32)		.429 (10.90)	.116 (2.95)	

### Type N Crimp – Crimp Plugs for Flexible Cable

1. Identify connector parts. (3 piece parts)
2. Strip cable to dimensions shown. Do not nick braid or center conductor. Slide the crimp sleeve onto the jacket; crimp narrow end first.
3. Crimp and solder the contact onto the center conductor using the recommended crimp hex or the minimum amount of solder for a good joint. Note: Contacts may need to be pre-fit onto the center conductor and soldered through the hole.
4. Flare the braid and slide the connector body over the contact and under the braid. Then seat the body FIRMLY onto the contact; the cable may need to be held in a clamping fixture. Arrange the braid uniformly around the crimp stem, then slide the crimp sleeve forward to the body and crimp the sleeve using the recommended crimp hex.

\* Cable Assembly Notes: The contact of the CPN-8/110 Connector fits RG-8 cable types with a center conductor diameter up to .110".

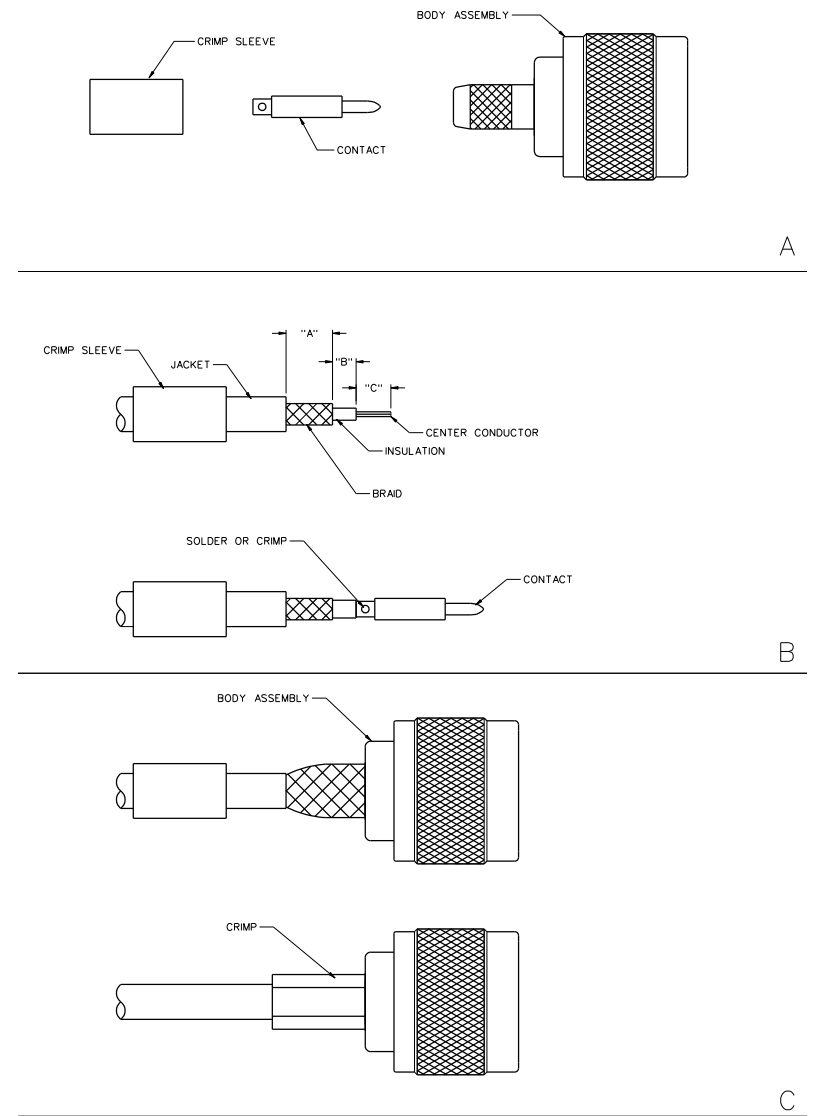

Part No.	Cable Type	Wire Gauge	Wire Decimal	Jacket O.D.	Hex Size	Contact Crimp Hex	Recommended Crimp Tool
CPN-1	RG-58	18	.043 (1.09)	.185 (4.07)-.205 (5.21)	.213 (5.41)	.100 (2.54)	24-312
CPN-2	RG-59	22	.0253 (6.43)	.220 (5.59)-.250 (6.35)	.255 (6.48)	.100 (2.54)	24-312
CPN-8	RG-8, 213	13	.072 (1.83)	.400 (10.16)-.410 (10.44)	.406 (10.31)	.102 (2.59)	24-7712P
CPN-8/110*	RG-58 Low Loss, 213	10	.110 (2.80)	.400 (10.16)-.410 (10.44)	.406 (10.31)	.102 (2.59)	24-7712P
CPN-16	Proflex RG-450	18	.056 (1.42)	.220 (5.59)-.250 (6.35)	.255 (6.48)	.100 (2.54)	24-312
CPN-17	RG-8X	16	.065 (1.65)	.220 (5.59)-.250 (6.35)	.255 (6.48)	.100 (2.54)	24-312
CPN-142T	RG-142TFE	20	.034 (0.86)	200 (5.08)-.220 (5.59)	.213 (5.41)	.100 (2.54)	24-312

### Type N Straight Plug Crimp Style for RG-316 and 316DS Flexible Cable

- 1 Identify connector parts. (3 piece parts)
- 2 Strip cable to dimensions shown. Do not nick center conductor. A wire stripper of correct size is recommended for this step. Tin center conductor if contact will be solder attached. Do not tin center conductor if contact will be crimp attached. Slide crimp sleeve onto jacket of cable.
- 3 Assemble rear contact onto cable as shown  
Rear contact should butt against cable dielectric during attachment.  
**Solder Attachment:** Solder rear contact to center conductor through solder hole using .020 (.051) diameter flux core solder wire. Use a minimum amount of solder for a good joint.  
**Crimp Attachment:** Crimp rear contact to center conductor using Johnson indent hand tool 140-0000-970. Crimp location should be centered between end of rear contact and solder hole using positioning tool 140-0000-971. Crimp attachment to solid center conductor cables is not recommended.
- 4 Flare braid and slide plug connector assembly over rear contact and under braid. Rear contact must engage fully with internal captivated plug contact. Cable jacket should be located near end of crimp stem when contacts are fully engaged.
- 5 Arrange braid uniformly around crimp stem. Slide crimp sleeve forward and crimp using Johnson ergonomic hand crimp frame 140-0000-967 with recommended hex size die set. Maintain forward pressure on cable while crimping.

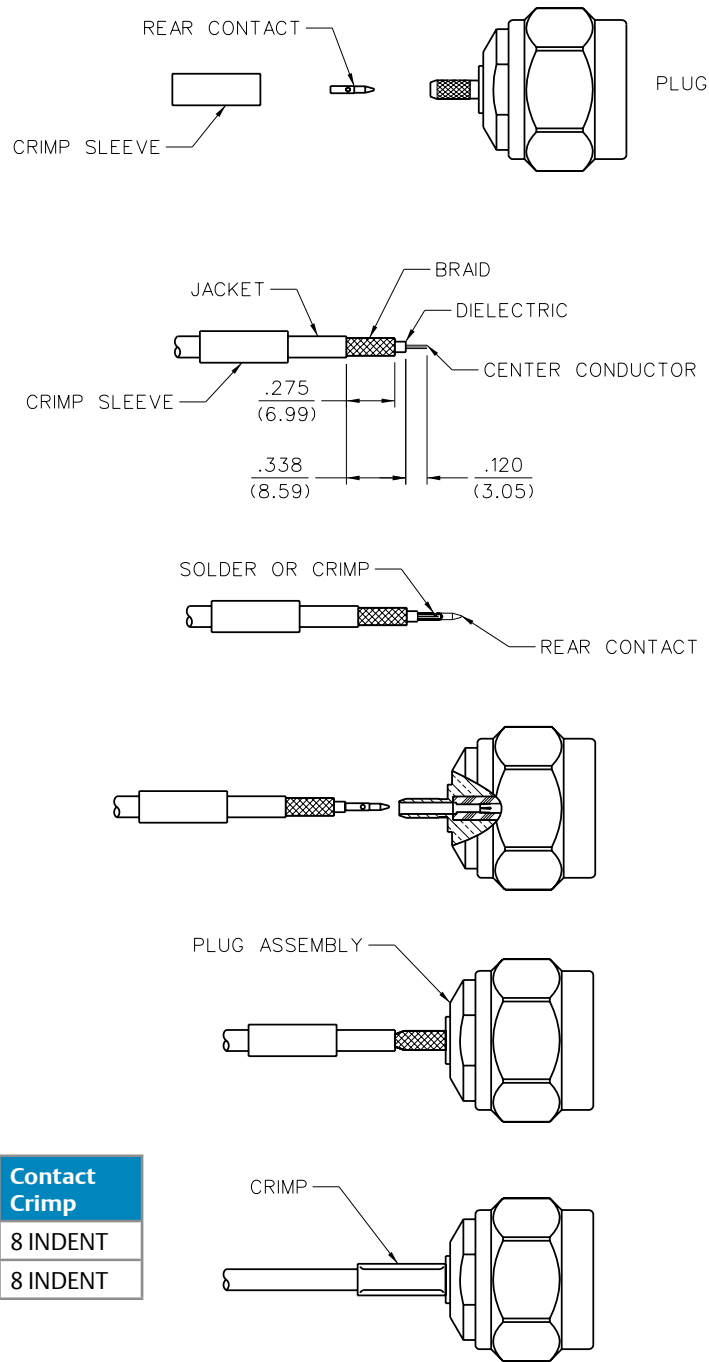

Cable Group	Part No.	Crimp Sleeve Hex Size	Contact Crimp
RG-316/U, 161, 174, 188	138-4403-007	.128 (3.25)	8 INDENT
RG-316 DS, 188 DS	138-4404-007	.151 (3.84)	8 INDENT

	Assembly
Tool	138-4403/4404-007
Crimp Frame	140-0000-967
Die Set	140-0000-990
Contact Tool	140-0000-970
Positioner	140-0000-971

### Type N Straight Plug Crimp Style for RG-58, 142, 213, 214 and LMR-400 Flexible Cable

- 1 Identify connector parts. (3 piece parts)
- 2 Strip cable to dimensions shown. Do not nick center conductor. A wire stripper of correct size is recommended for this step. Tin center conductor if contact will be solder attached. Do not tin center conductor if contact will be crimp attached. Slide crimp sleeve onto jacket of cable.
- 3 Assemble plug contact onto cable as shown.  
Plug contact should butt against cable dielectric during attachment.  
**Solder Attachment:** Solder plug contact to center conductor through solder hole using .020 (.051) diameter flux core solder wire. Use a minimum amount of solder for a good joint.  
**Crimp Attachment:** Crimp plug contact to center conductor using Johnson ergonomic hand crimp frame 140-0000-967 with recommended hex size die set. Crimp location should be on end of plug contact next to cable dielectric. Crimp attachment to solid center conductor cables is not recommended.
- 4 Flare braid and slide plug connector assembly over plug contact and under braid. Seat plug connector assembly firmly onto contact. Arrange braid uniformly around crimp stem. Slide crimp sleeve forward and crimp using Johnson ergonomic hand crimp frame 140-0000-967 with recommended hex size die set. Maintain forward pressure on cable while crimping.

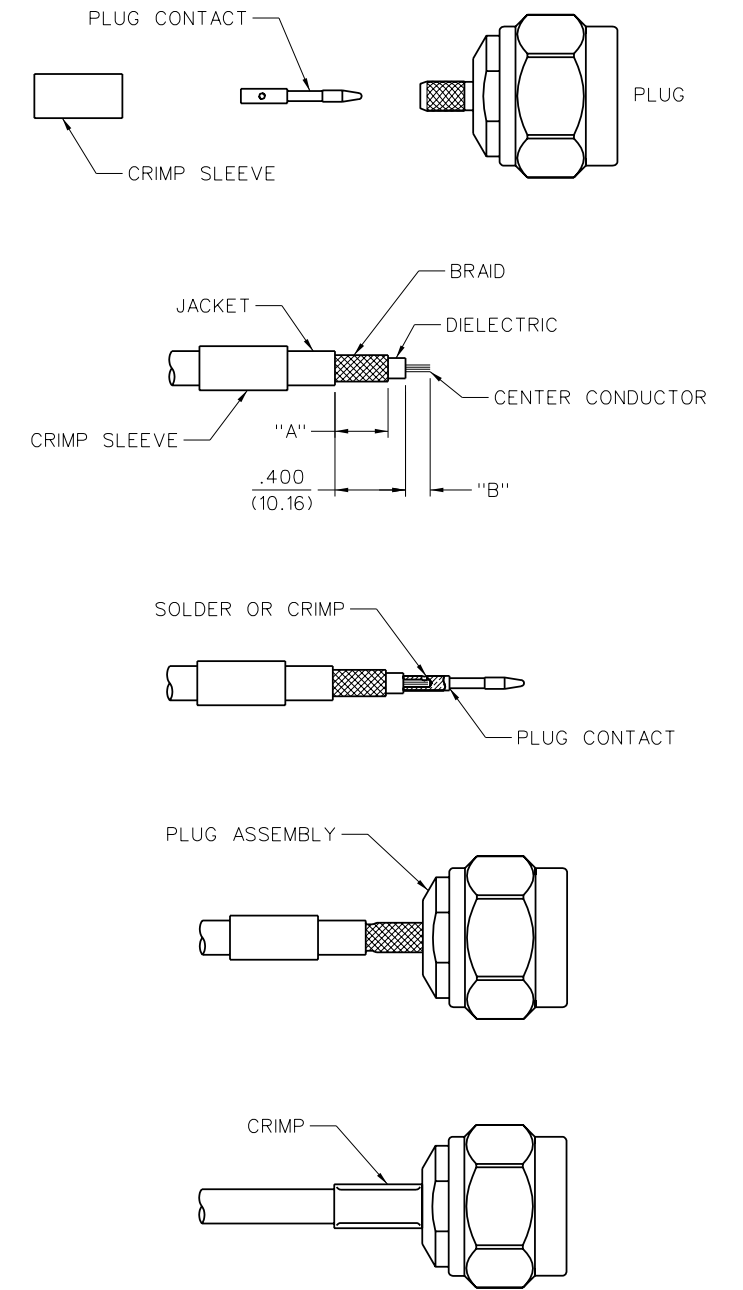

Cable Group	Part No.	"A"	"B"	Crimp Sleeve Hex Size	Contact Hex Size
RG-58/U, 141, 303	138-4407-007	.301 (7.65)	.140 (3.56)	.213 (5.41)	.068 (1.73)
RG-55/U, 142, 223, 400	138-4408-007	.301 (7.65)	.140 (3.56)	.213 (5.41)	.068 (1.73)
RG-8, 213	138-4416-007	.385 (9.78)	.170 (4.32)	.429 (10.90)	.111 (2.82)
RG-9, 214	138-4418-007	.385 (9.78)	.170 (4.32)	.429 (10.90)	.111 (2.82)
LMR-400, BELDEN 9913	138-4449-007	.385 (9.78)	.170 (4.32)	.429 (10.90)	.116 (2.95)

	Assembly	
Tool	138-4407/4408-007	138-4416/4418/4449-007
Crimp Frame	140-0000-967	140-0000-967
Die Set	140-0000-990	140-0000-991

For more information, please contact customer service at (507) 833-8822 or (800) 247-8256 • www.EmersonConnectivity.com  
Illustrations are shown in inches (millimeters).

### Type N Right Angle Plug Crimp Style for RG-316, 316DX, 58, and 142 Flexible Cable

1. Identify connector parts. (3 piece parts)
2. Strip cable to dimensions shown. Do not nick center conductor. A wire stripper of correct size is recommended for this step. Twist stranded center conductor into tight bundle and tin (optional). Slide crimp sleeve onto jacket of cable.
3. Flare braid and slide plug connector assembly over cable dielectric and under braid. Make sure cable dielectric bottoms against plug contact as shown. Solder center conductor to contact through rear access port. Use a minimum amount of solder for a full fillet joint.
4. Arrange braid uniformly around crimp stem. Slide crimp sleeve forward and crimp using Johnson ergonomic hand crimp frame 140-0000-967 with recommended hex size die set. Screw end cap into access port.

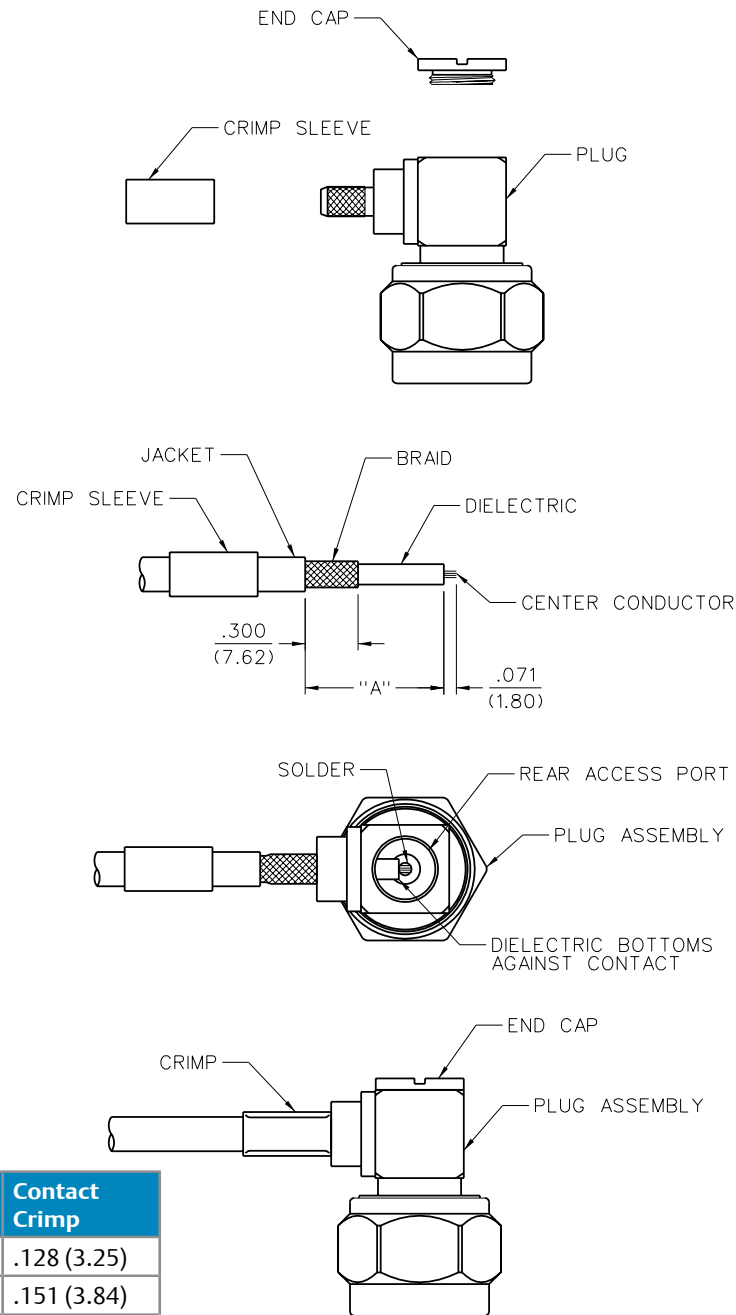

Cable Group	Part No.	Crimp Sleeve Hex Size	Contact Crimp
RG-316/U, 161, 174, 188	138-4403-107	.755 (19.18)	.128 (3.25)
RG-316 DS, 188 DS	138-4404-107	.755 (19.18)	.151 (3.84)
RG-58/U, 141, 303	138-4407-107	.788 (20.02)	.213 (5.41)
RG-55/U, 142, 223, 400	138-4408-107	.788 (20.02)	.213 (5.41)

	Assembly
Tool	138-4403/4404/4407/4408-107
Crimp Frame	140-0000-967
Die Set	140-0000-990

### Type N Right Angle Plug Crimp Style for RG-213 and 214 Flexible Cable

1. Identify connector parts. (3 piece parts)
2. Strip cable to dimensions shown. Do not nick center conductor. A wire stripper of correct size is recommended for this step. Slide crimp sleeve onto jacket of cable.
3. Flare braid and slide plug connector assembly over cable dielectric and under braid. Make sure center conductor is contained within plug contact as shown. Center conductor should not protrude above slots in plug contact and cable dielectric should not touch plug contact. Solder center conductor to plug contact through rear access port. Use a minimum amount of solder for a full fillet joint.
4. Arrange braid uniformly around crimp stem. Slide crimp sleeve forward and crimp using Johnson ergonomic hand crimp frame 140-0000-967 with recommended hex size die set. Screw end cap into access port.

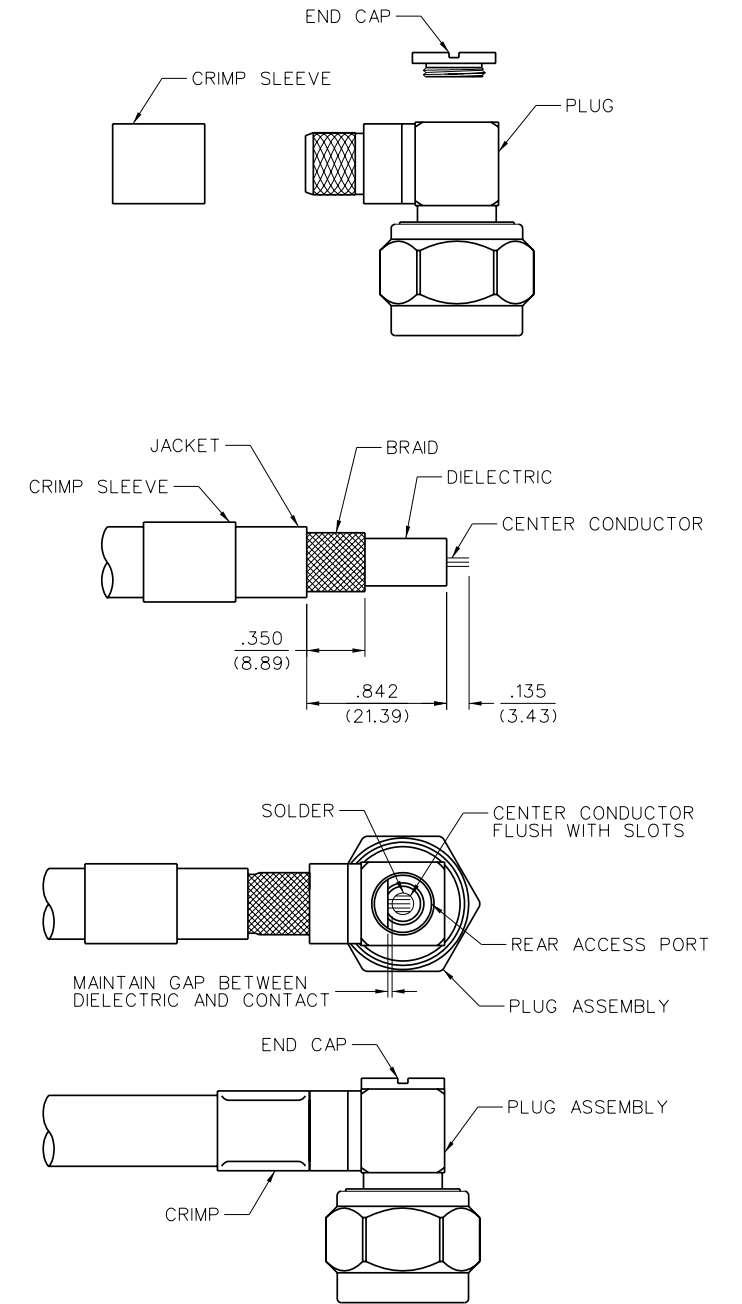

Cable Group	Part No.	Contact Crimp
RG-8, 213	138-4416-107	.429 (10.90)
RG-9, 214	138-4418-107	.429 (10.90)

	Assembly
Tool	138-4416/4418-107
Crimp Frame	140-0000-967
Die Set	140-0000-991

### Type N Straight Plug Solder Style for Semi-Rigid Cable

1. Identify connector parts (2 piece parts) and tools (5 piece parts).
2. Strip cable jacket and dielectric to dimension shown. Do not nick center conductor.
3. Place plug contact onto center conductor, insert appropriate sized solder shim between cable jacket and contact.
4. Insert contact into location fixture and clamp cable in vise. Tighten stop screw until light pressure is applied between contact, solder shim and cable jacket.
5. Solder contact to center conductor through solder hole using .020 (.051) diameter flux core solder wire. Use a minimum amount of solder for a good joint.
6. After solder joint has cooled, loosen stop screw and remove solder shim. Remove cable from vise and remove any excess solder from contact with a sharp blade and clean all debris from contact and cable.
7. Insert contact and cable into plug connector assembly, making sure cable jacket bottoms out against internal shoulder of connector assembly. Insert location fixture into connector assembly and clamp cable in vise. Tighten stop screw until light pressure is applied between connector assembly and cable jacket.
8. Solder connector body to cable jacket, using a minimum amount of solder for a full fillet joint. Allow assembly to cool before removing connector from vise.

Cable Group	Part No.	"A"
RG-405, .086 Semi-Rigid	138-4693-001	.085 (2.16)
RG-402, .141 Semi-Rigid	138-4694-001	.085 (2.16)
RG-401, .250 Semi-Rigid	138-4696-001	.100 (2.54)

Assembly			
Tool	138-4693-001	138-4694-001	138-4696-001
Solder Shim	140-0000-984	140-0000-984	140-0000-985
Location Fixture	140-0000-983	140-0000-983	140-0000-983
Cable Vise	140-0000-962	140-0000-962	140-0000-962
Clamp Inserts	140-0000-964	140-0000-965	140-0000-986

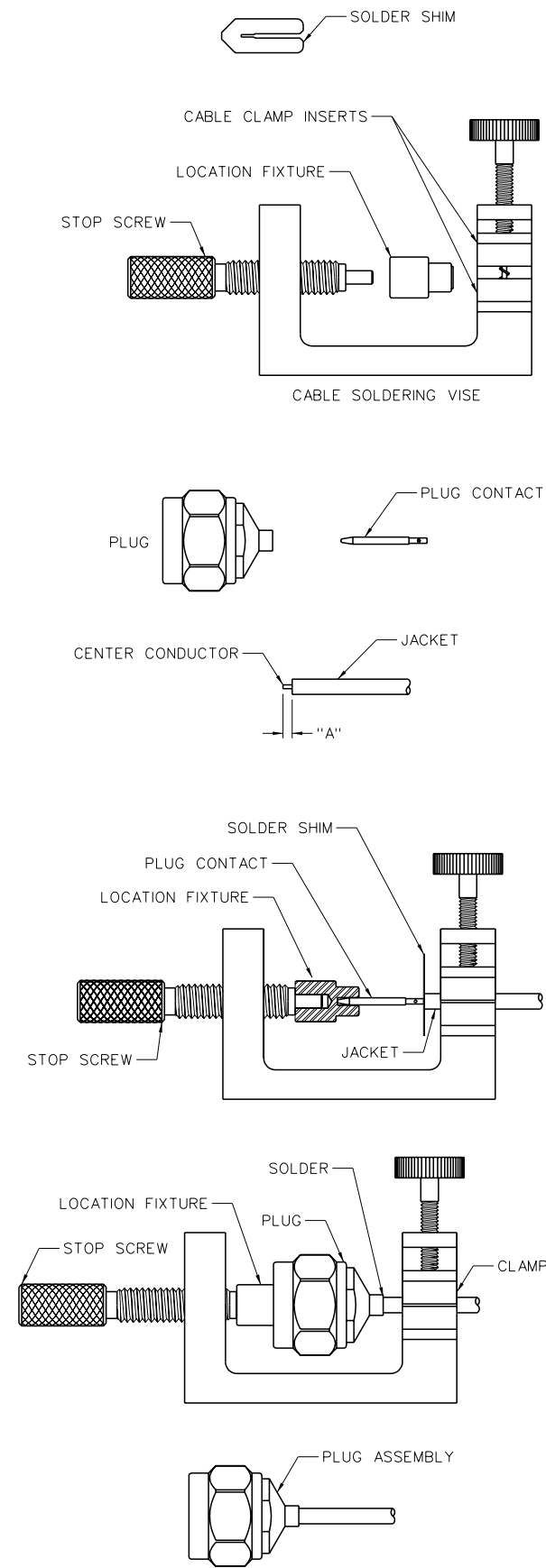

### Type N Straight Plug One Piece Style for Semi-Rigid Cable

1. Identify connector and tools. (4 piece parts)
2. Strip cable jacket and dielectric to dimension shown. Do not nick center conductor.
3. Bevel end of cable center conductor per appropriate dimensional profile.
4. Clean all debris from prepared cable and insert cable into connector assembly, making sure cable jacket bottoms out against internal shoulder of connector assembly and center conductor engages with internal captivated plug contact.
5. Insert location fixture into connector assembly and clamp cable in vise. Tighten stop screw until light pressure is applied between connector assembly and cable jacket.
6. Solder connector body to cable jacket, using a minimum amount of solder for a full fillet joint. Allow assembly to cool before removing connector from vise.

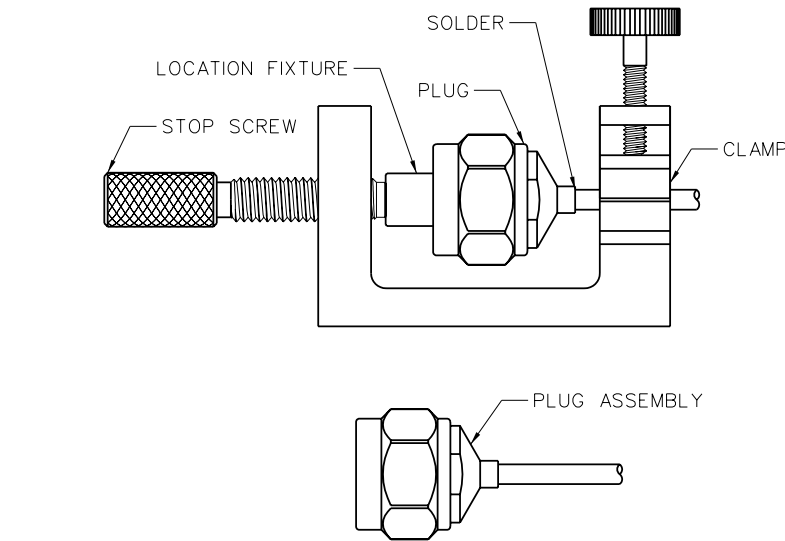

Cable Group	Part No.	"A"	"B"
RG-405, .086 Semi-Rigid	138-4693-011	.085 (2.16)	.014 (0.36)
RG-402, .141 Semi-Rigid	138-4694-011	.085 (2.16)	.022 (0.56)
RG-401, .250 Semi-Rigid	138-4696-011	.150 (3.81)	.045 (1.14)

Assembly			
Location Fixture	140-0000-983	140-0000-983	140-0000-983
Cable Vise	140-0000-962	140-0000-962	140-0000-962
Clamp Inserts	140-0000-964	140-0000-965	140-0000-986
Stop Screw	140-0000-981	140-0000-981	140-0000-981

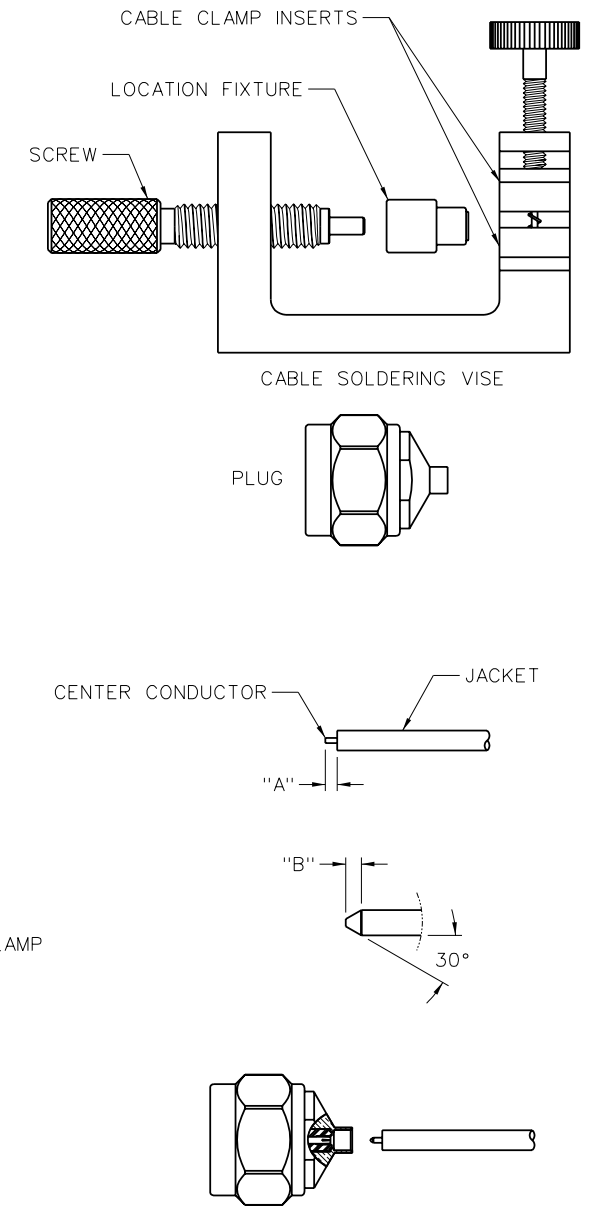

### Type N Bulkhead Jack Crimp Style for RG-316 and 316DS Flexible Cable

1. Identify connector parts. (6 piece parts)
2. Strip cable to dimensions shown. Do not nick center conductor. A wire stripper of correct size is recommended for this step. Tin center conductor if contact will be solder attached. Do not tin center conductor if contact will be crimp attached. Slide crimp sleeve onto jacket of cable.
3. Assemble rear contact onto cable as shown. Rear contact should butt against cable dielectric during attachment.  
**Solder Attachment:** Solder rear contact to center conductor through solder hole using .020 (.051) diameter flux core solder wire. Use a minimum amount of solder for a good joint.  
**Crimp Attachment:** Crimp rear contact to center conductor using Johnson indent hand tool 140-0000-970. Crimp location should be centered between end of rear contact and solder hole using positioning tool 140-0000-971. Crimp attachment to solid center conductor cables is not recommended.
4. Flare braid and slide bulkhead jack connector assembly over rear contact and under braid. Rear contact must engage fully with internal captivated jack contact. Cable jacket should be located near end of crimp stem when contacts are fully engaged.
5. Arrange braid uniformly around crimp stem. Slide crimp sleeve forward and crimp using Johnson ergonomic hand crimp frame 140-0000-967 with recommended hex size die set. Maintain forward pressure on cable while crimping.
6. Add gasket, lock washer and mounting nut when installing.

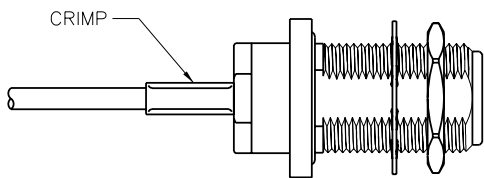
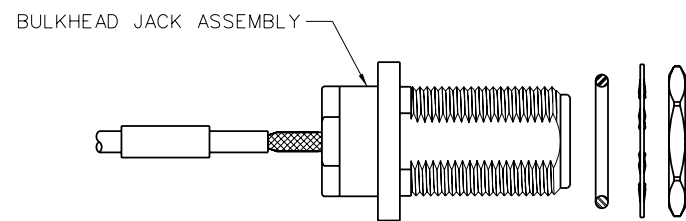
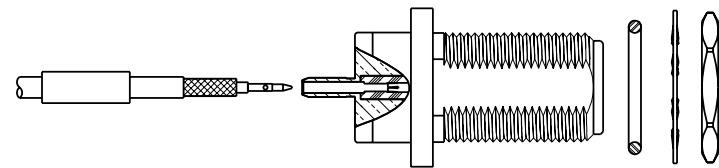
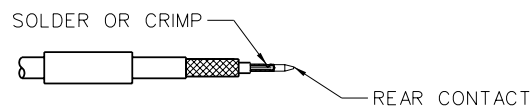
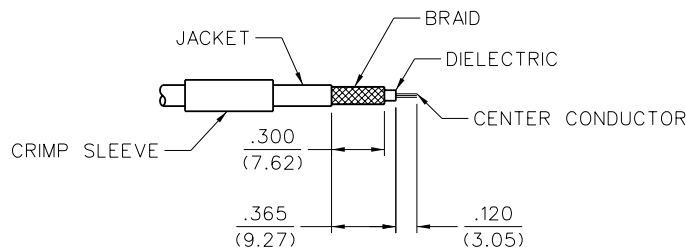
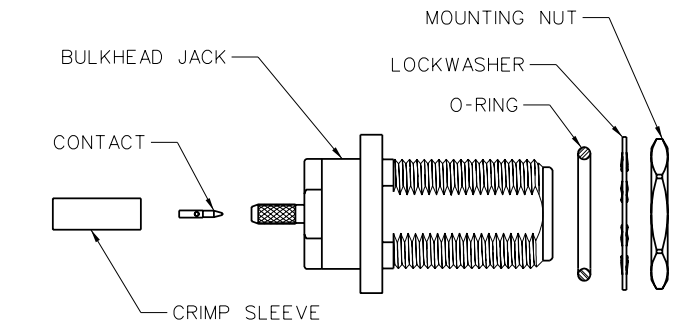

Cable Group	Part No.	Crimp Sleeve Hex Size	Contact Crimp
RG-316/U, 161, 174, 188	138-4303-407	.128 (3.25)	8 INDENT
RG-316 DS, 188 DS	138-4304-407	.151 (3.84)	8 INDENT

	Assembly
Die Set	140-0000-990
Contact Tool	140-0000-970
Positioner	140-0000-971

### Type N Bulkhead Jack Solder Style for Semi-Rigid Cable

1. Identify connector parts (8 piece parts) and tools (4 piece parts).
2. Strip cable jacket and dielectric to dimension shown. Do not nick center conductor. Clean all debris from cable.
3. Slide stem over cable jacket, keeping stem correctly oriented to end of cable.
4. Insert jack contact into rear insulator. Make sure insulator is correctly oriented to contact. Place jack contact and rear insulator onto center conductor, keeping insulator correctly oriented between cable jacket and contact.
5. Slide stem away from jack contact. Insert contact into stop screw and clamp cable in vise. Tighten stop screw until light pressure is applied between jack contact, rear insulator and cable jacket.
6. Solder jack contact to center conductor through solder hole using .020 (.051) diameter flux core solder wire. Use a minimum amount of solder for a good joint.
7. After solder joint has cooled, remove cable from vise and remove any excess solder from jack contact with a sharp blade and clean all debris from contact and rear insulator.
8. Slide stem over rear insulator and tighten stem into location fixture until stem bottoms out.
9. Insert cable into vise, but do not clamp. Insert jack contact into stop screw and tighten location fixture until stop screw bottoms out. Clamp cable in vise.
10. Solder stem to cable jacket, using a minimum amount of solder for a full fillet joint. Allow assembly to cool before removing from vise.
11. After solder joint has cooled, un-clamp cable and remove location fixture from stop screw and cable assembly. Insert front insulator into bulkhead jack body. Insert cable assembly into body and tighten to 25-30 in-lbs.
12. Add gasket, lock washer and mounting nut when installing connector to panel.

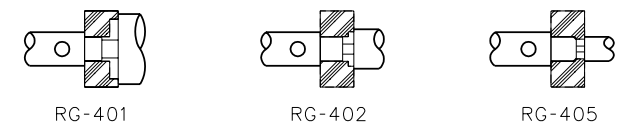
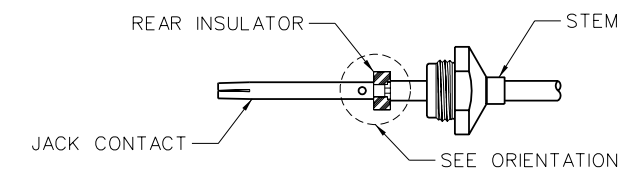
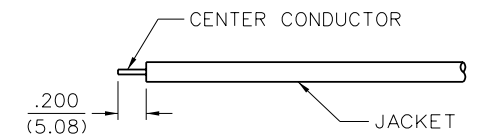
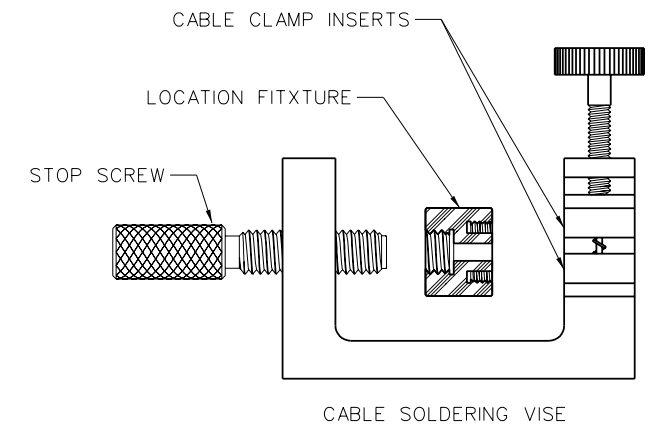
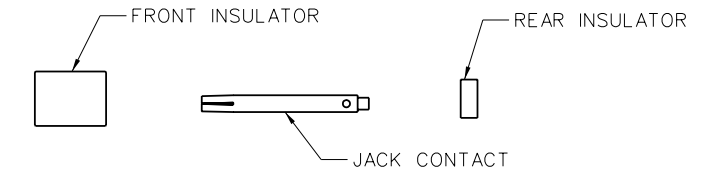
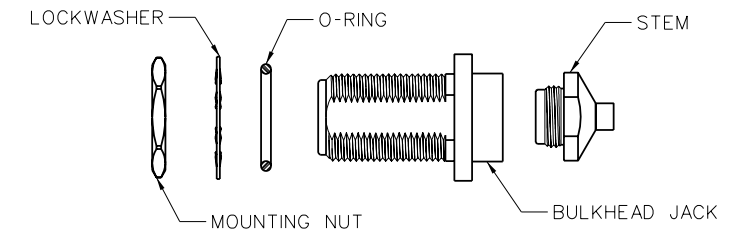

### Type N Bulkhead Jack Solder Style for Semi-Rigid Cable (cont'd from last page)

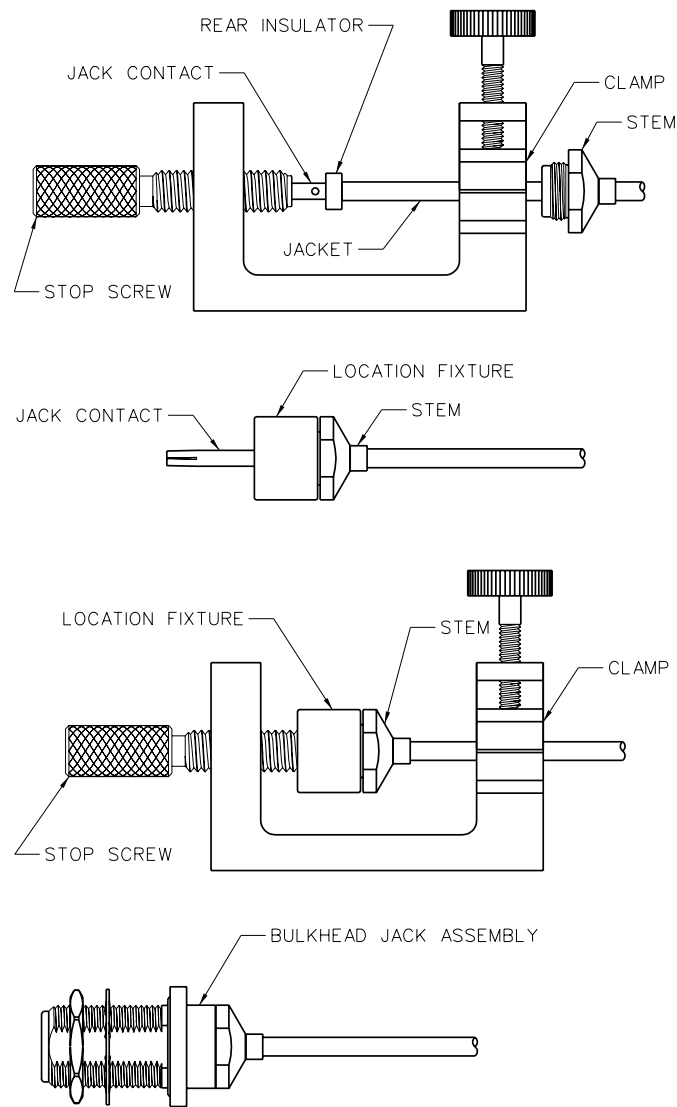

Cable Group	Part No.
RG-405, .086 Semi-Rigid	138-4593-401
RG-402, .141 Semi-Rigid	138-4594-401
RG-401, .250 Semi-Rigid	138-4596-401

Assembly			
Tool	138-4593-401	138-4594-401	138-4596-401
Stop Screw	140-0000-972	140-0000-972	140-0000-972
Cable Vise	140-0000-962	140-0000-962	140-0000-962
Clamp Inserts	140-0000-964	140-0000-965	140-0000-986
Location Fixture	140-0000-987	140-0000-988	140-0000-989

### Type N Bulkhead Jack Crimp Style for RG-58, 142, 213, 214 and LMR-400 Flexible Cable

1. Identify connector parts. (6 piece parts)
2. Strip cable to dimensions shown. Do not nick center conductor. A wire stripper of correct size is recommended for this step. Tin center conductor if contact will be solder attached. Do not tin center conductor if contact will be crimp attached. Slide crimp sleeve onto jacket of cable.
3. Assemble jack contact onto cable as shown. Jack contact should butt against cable dielectric during attachment.  
**Solder Attachment:** Solder jack contact to center conductor through solder hole using .020 (.051) diameter flux core solder wire. Use a minimum amount of solder for a good joint.  
**Crimp Attachment:** Crimp jack contact to center conductor using Johnson ergonomic hand crimp frame 140-0000-967 with recommended hex size die set. Crimp location should be on end of jack contact next to cable dielectric. Crimp attachment to solid center conductor cables is not recommended.
4. Flare braid and slide bulkhead jack connector assembly over jack contact and under braid. Seat bulkhead jack connector assembly firmly onto contact. Arrange braid uniformly around crimp stem. Slide crimp sleeve forward and crimp using Johnson ergonomic hand crimp frame 140-0000-967 with recommended hex size die set. Maintain forward pressure on cable while crimping.

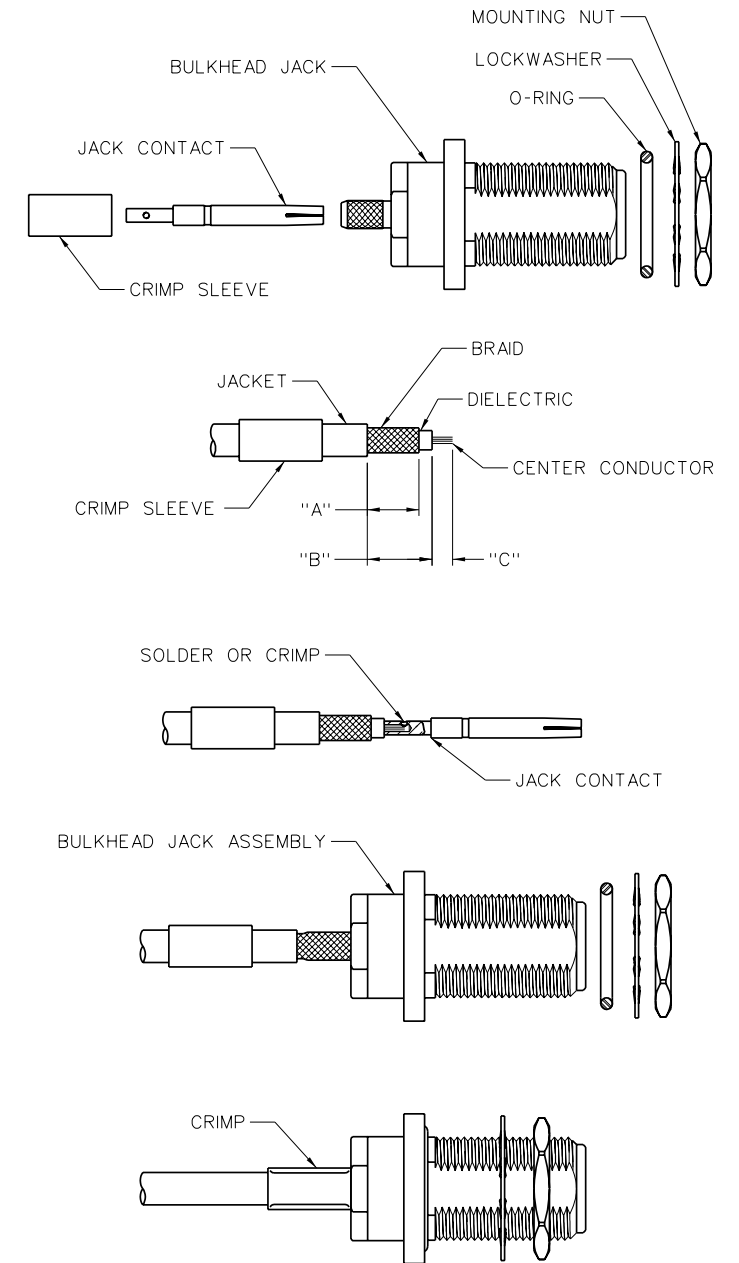

Cable Group	Part No.	"A"	"B"	Crimp Sleeve "C"	Contact Hex Size	Hex Size
RG-58/U, 141, 303	138-4307-407	.310 (7.87)	.389 (9.88)	.135 (3.43)	.213 (5.41)	.068 (1.73)
RG-55/U, 142, 223, 400	138-4308-407	.310 (7.87)	.389 (9.88)	.135 (3.43)	.213 (5.41)	.068 (1.73)
RG-8, 213	138-4316-407	.385 (9.78)	.400 (10.16)	.165 (4.19)	.429 (10.90)	.111 (2.82)
RG-9, 214	138-4318-407	.385 (9.78)	.400 (10.16)	.165 (4.19)	.429 (10.90)	.111 (2.82)

Assembly		
Tool	138-4307/4308-407	138-4316/4318/4349-407
Crimp Frame	140-0000-967	140-0000-967
Die Set	140-0000-990	140-0000-991

For more information, please contact customer service at (507) 833-8822 or (800) 247-8256 • www.EmersonConnectivity.com

Illustrations are shown in inches (millimeters).

### Crimp Type Straight Cable Termination for Flexible Cable

1. Identify connector parts. (2 piece parts)
2. Strip cable to dimensions shown. Do not nick braid or center conductor. A wire stripper of correct size is recommended for this step. Twist stranded center conductor into tight bundle and tin. Slide crimp sleeve onto cable as shown.
3. Flare braid and slide cable into body making certain that the cable insulation is flush with bottom of connector.
4. Arrange braid uniformly around crimp stem. Slide crimp sleeve over braid and crimp securely using recommended crimp tool.

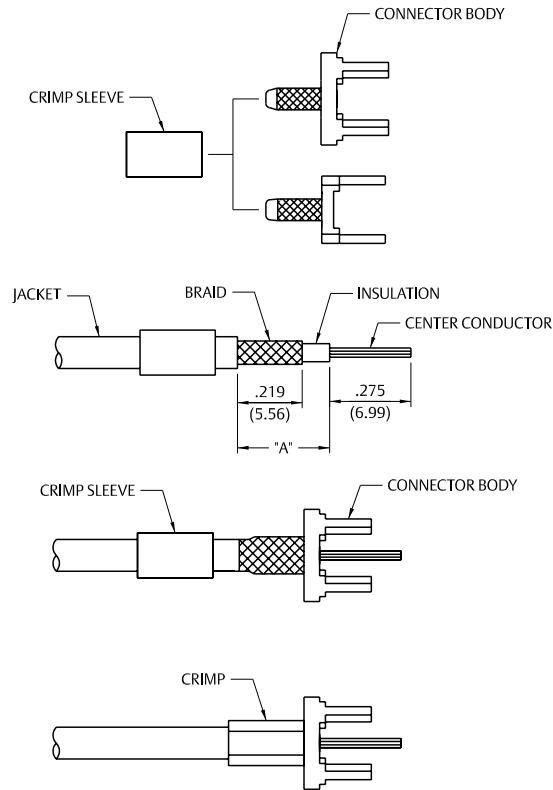

Cable Group	Part No.	"A"	Crimp Hex
RG-178/U, 196	142-0002-221/226	.259 (6.58)	.105 (2.67)
RG-316/U, 161, 174, 179, 187, 188	142-0003-201/206	.312 (7.92)	.128 (3.25)
	142-0003-231/236	.259 (6.58)	.128 (3.25)
	142-0003-241/246	.259 (6.58)	.128 (3.25)
RG-316 DS, 188 DS	142-0004-201/206	.312 (7.92)	.151 (3.83)
	142-0004-211/216	.259 (6.58)	.151 (3.83)
	142-0004-221/226	.259 (6.58)	.151 (3.83)

### Crimp Type Right Angle Cable Termination for Flexible Cable

1. Identify connector parts. (2 piece parts)
2. Strip cable to dimensions shown. Do not nick braid or center conductor. A wire stripper of correct size is recommended for this step. Twist stranded center conductor into tight bundle and tin. Slide crimp sleeve onto cable as shown.
3. Flare braid and slide cable into body making certain that the cable insulation is flush with bottom of connector body.
4. Arrange braid uniformly around crimp stem. Slide crimp sleeve over braid and crimp securely using recommended crimp tool.

Cable Group	Part No.	Crimp Hex
RG-316/U, 161, 174, 179, 187, 188	142-0003-301/306	.128 (3.25)
RG-316 DS, 188 DS	142-0004-301/306	.151 (3.83)

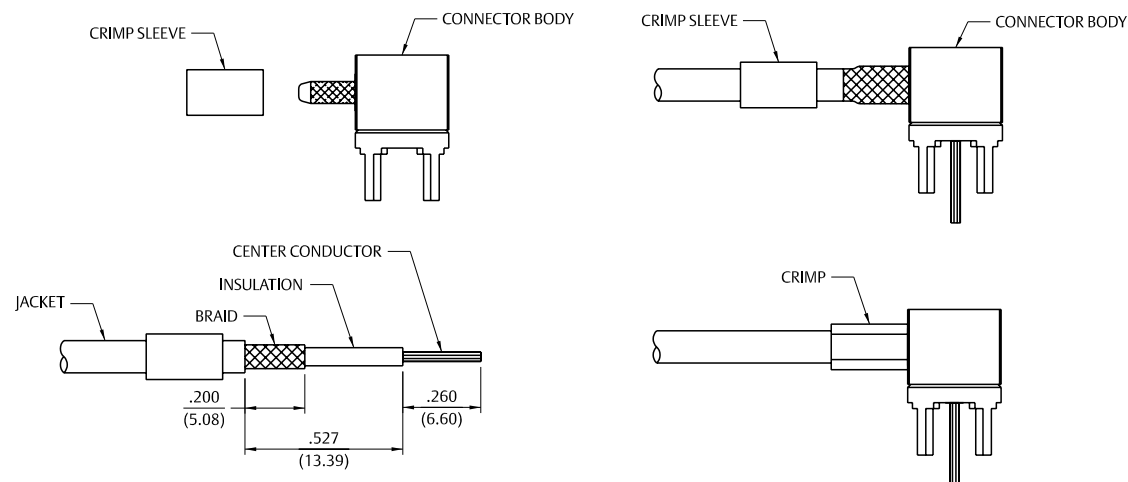

### Crimp Type Straight Cable Termination for End Launch

1. Identify connector parts. (2 piece parts)
2. Strip cable to dimensions shown. Do not nick braid or center conductor. A wire stripper of correct size is recommended for this step. Twist stranded center conductor into tight bundle and tin. Slide crimp sleeve onto cable as shown.
3. Flare braid and slide cable into body making certain that the cable insulation is flush with bottom of connector body.
4. Arrange braid uniformly around crimp stem. Slide crimp sleeve over braid and crimp securely using recommended crimp tool.

Cable Group	Part No.	Crimp Hex
RG-178/U, 196	142-0002-811	.105 (2.67)
RG-316/U, 161, 174, 179, 187, 188	142-0003-801	.128 (3.25)
	142-0003-811	.128 (3.25)
RG-316 DS, 188 DS, 179 DS, 187 DS	142-0004-801	.151 (3.84)
	142-0004-811	.151 (3.84)
RG-58/U, 141, 303	142-0007-801	.213 (5.41)
	142-0007-811	.213 (5.41)
RG-142/U, 55, 223, 400	142-0008-801	.213 (5.41)
	142-0008-811	.213 (5.41)

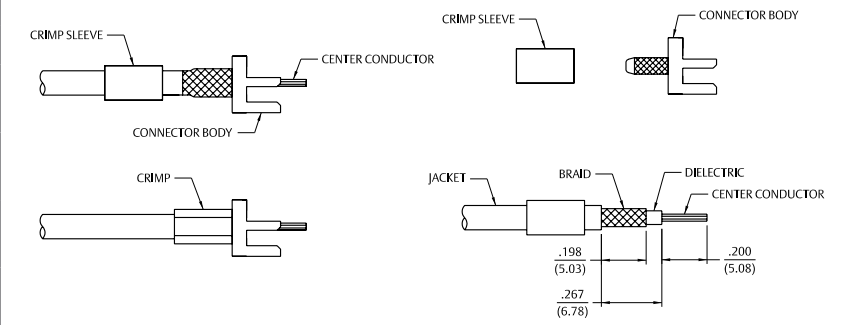

### Solder Type Straight Cable Termination for End Launch

1. Identify connector parts. (1 piece part)
2. Strip cable to dimensions shown. Do not nick braid or center conductor.
3. Insert cable into body making sure cable is bottomed against shoulder body. Solder body to cable. Use a minimum amount of heat to minimize cable dielectric movement.

Cable Group	Part No.
RG-405/U (.086 Semi-Rigid)	142-0093-801/806
RG-402/U (.141 Semi-Rigid)	142-0094-801/806
.250 Semi-Rigid	142-0096-801/806

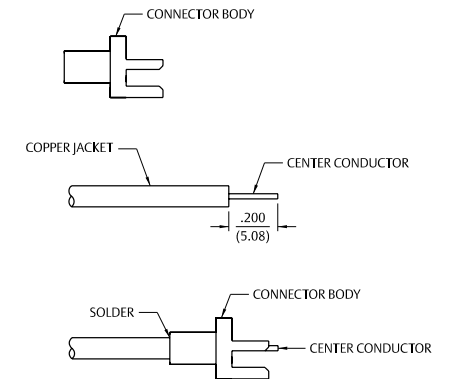

### Solder Type Straight Cable Termination for End Launch Surface Mount

1. Identify connector parts. (2-piece parts)
2. Strip cable to dimensions shown. Do not nick braid or center conductor. A wire stripper of correct size is recommended for this step. Twist stranded center conductor into tight bundle and tin. Slide crimp sleeve onto cable as shown.
3. Flare braid and slide cable into body making certain that the cable dielectric is flush with the end of the connector body.
4. Arrange braid uniformly around crimp sleeve. Slide crimp sleeve over braid and crimp securely using recommended crimp tool.

Cable Group	Part No.	Crimp Hex
RG-178/U, 196	142-0002-821	.105 (2.67)

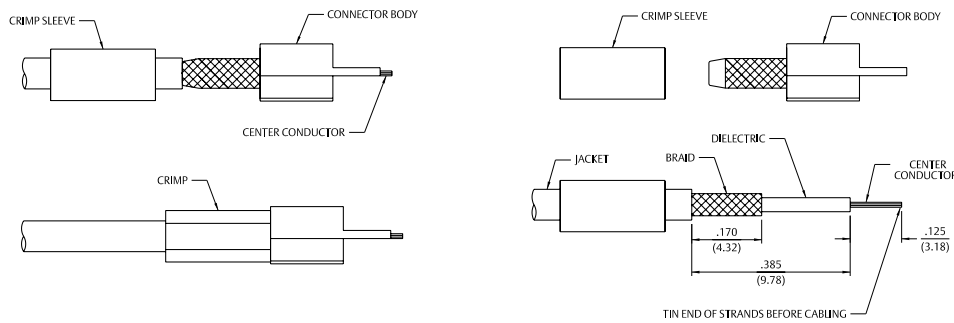

### kwiQMAt<sup>™</sup> Crimp Type Right Angle Plugs for Flexible Cable

1. Identify connector parts. (3 piece parts)
2. Strip cable to dimensions shown. Do not nick braid or center conductor. Twist stranded center conductor into tight bundle and tin (optional). Slide crimp sleeve onto cable as shown.
3. Flare braid and slide cable into body making certain that the cable dielectric bottoms on center contact. Solder center conductor to contact through the rear access port. Use a minimum amount of solder for a full fillet joint. **.020 (0.51) diameter solder is recommended.**
4. Arrange braid uniformly around crimp stem. Slide crimp sleeve over braid and crimp securely using recommended crimp tool. Place expansion cap in access port and seat with .187 (4.75) diameter flat punch. Shrink heat shrink tubing over crimp sleeve if applicable.

Cable Type	Part No.	Crimp Hex
RG-316	146-0403-107	.128 (3.25)
RG-316 DS	146-0404-107	.151 (3.83)

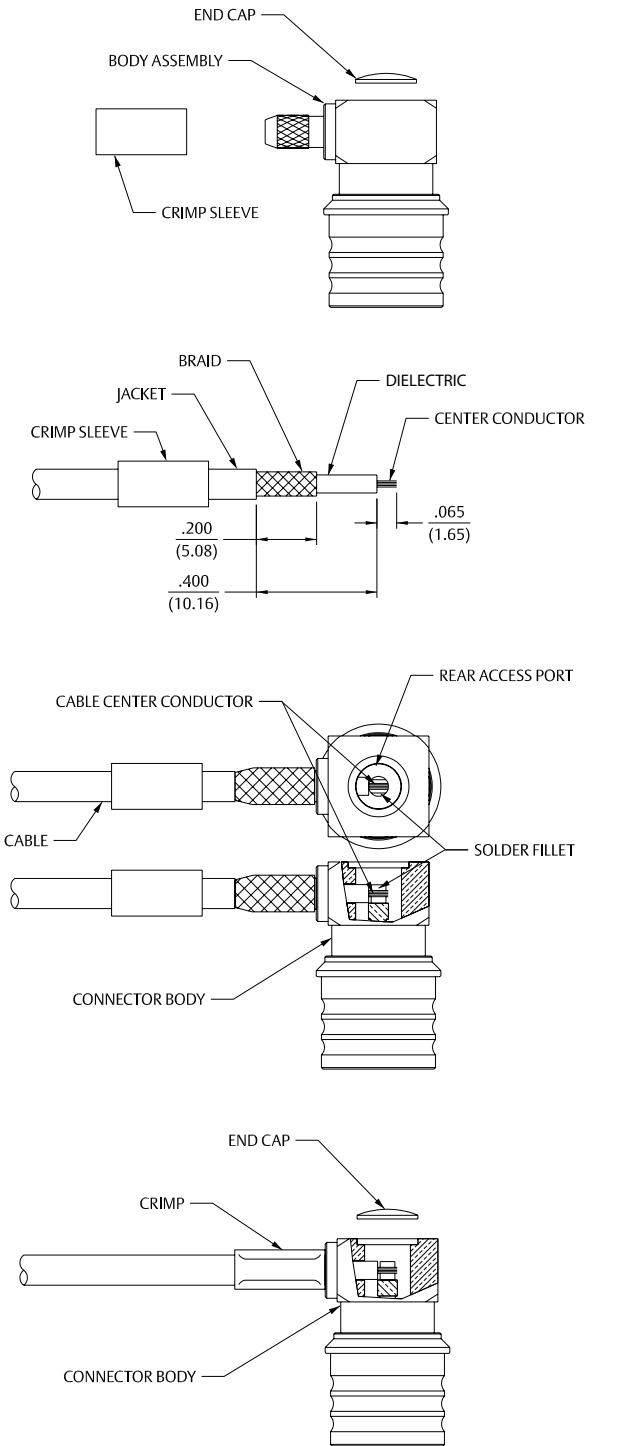



## kwiQMate™ Straight Plugs for Flexible Cable – Crimp or Solder Contacts

1. Identify connector parts. (3 piece parts)
2. Strip cable to dimensions shown. Do not nick braid or center conductor. Tin center conductor if contact will be solder attached. Do not tin center conductor if contact is to be crimp attached. Slide heat shrink (as applicable) and crimp sleeve onto jacket of cable.
3. Assemble contact onto cable as shown.  
**Solder Attachment:** Solder contact to center conductor through solder hole using .020 (0.51) diameter solder. Use a minimum amount of solder for a good joint.  
**Crimp Attachment:** Crimp contact to center conductor using Johnson® Hand Tool 144-0000-910, setting #2. Crimp location should be centered between end of contact and X-hole. Crimp attachment to solid center conductor cables is not recommended.
4. Flare braid and slide body assembly over contact and under braid. Then seat body assembly firmly onto contact. The cable may have to be held in a clamping fixture. Arrange braid uniformly around crimp stem. Slide crimp sleeve forward and crimp using recommended crimp tool. Slide heat shrink forward and shrink (as applicable).

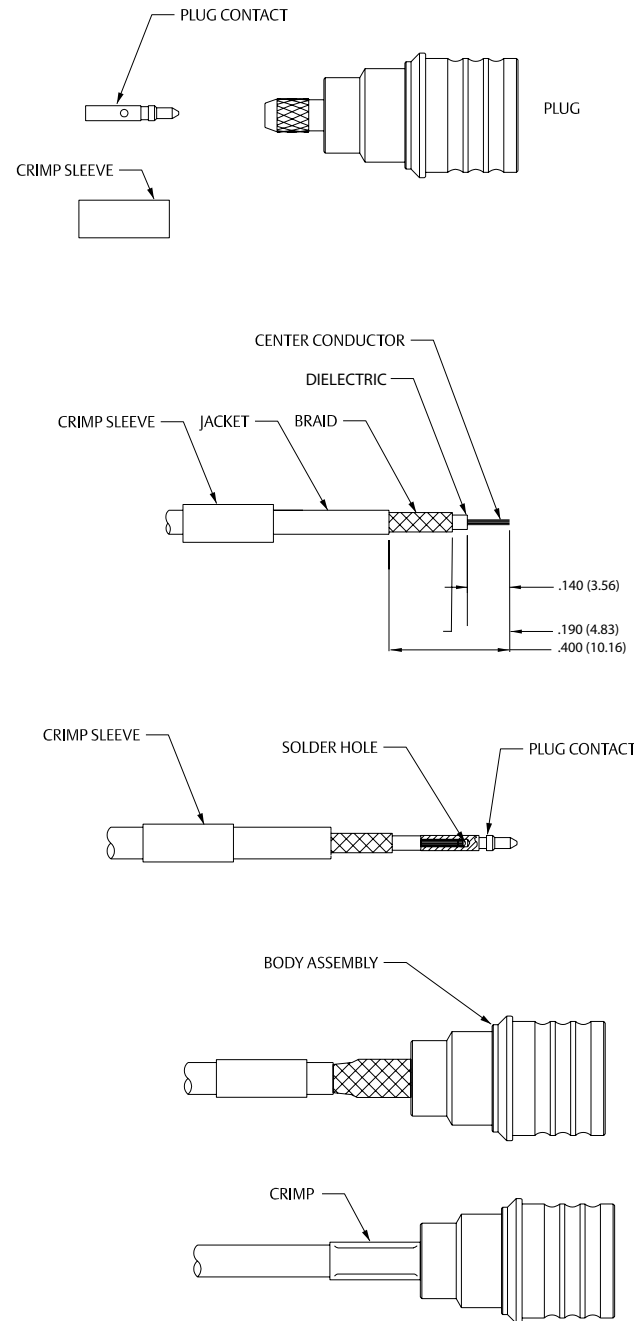

Cable Type	Part No.	Crimp Hex
RG-316	146-0403-007	.128 (3.25)
RG-316 DS	146-0404-007	.151 (3.83)

### Electronic Hardware

Other Information	
Assembly Tools .....	185
Capabilities .....	190
Cable Information .....	192
Assembly Instruction .....	193
Mounting Hole Layouts .....	194
Numerical Index .....	274
Competitor Cross Reference .....	280

3	MMCX Connectors
13	MCX Connectors
39	SMK Connectors
45	SMA Connectors
103	SMB Connectors
131	SMC Connectors
137	SMP Connectors
145	Type N Connectors
153	Shielded Cable Terminations
157	Between-Series Adapters
161	Fixed Length Cable Assemblies
173	Ultra Miniature Connectors (UMC)
181	kwiQMate™ Connectors
185	Tools
193	Assembly Instructions
257	Electronic Hardware
274	Index

While every precaution has been taken to ensure accuracy and completeness herein, Emerson Network Power Connectivity Solutions assumes no responsibility, and disclaims all liability for damages resulting from use of this information or for any errors or omissions. Specifications subject to change without notice.

## Horizontal Test Jacks – For Test Points

## Insulated Miniature



Silver Plating	
Part No.	Color
105-1101-001	White
105-1102-001	Red
105-1103-001	Black
105-1104-001	Green
105-1107-001	Yellow

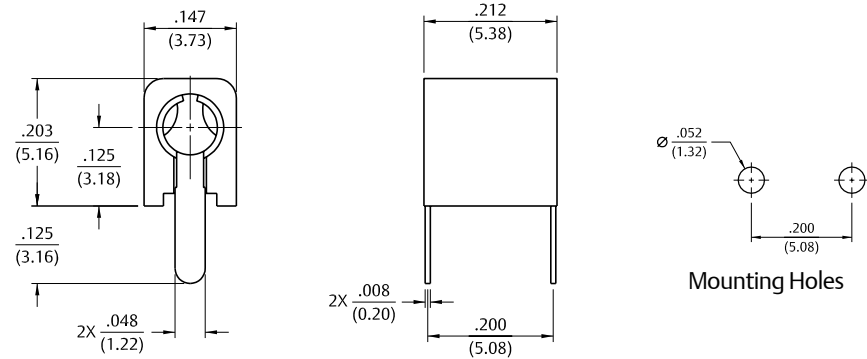

## SPECIFICATIONS

**Contact:** Copper aluminum alloy\*

**Finish:** Silver

**Body:** Nylon 6/6 per ASTM D4066

## RATINGS

**Current:** 5 amps

**Breakdown Voltage:** 2100 VRMS minimum

**Contact Resistance:** 0.010 ohms maximum

**Adjacent Jack C:** 1 pF maximum at 1 MHz

## For Standard Tip Plug:

**.080 (2.00) Diameter**

## FEATURES

- Contact protected from flux and solder
- Probe access from both ends
- Nylon UL approved for self extinguishing

\*A new material development that, for this application, meets or exceeds beryllium copper.

## Vertical Test Jacks – For Test Points

## Insulated: Formed Contact



Silver Plating	
Part No.	Color
105-2201-201	White
105-2202-201	Red
105-2203-201	Black
105-2204-201	Green
105-2207-201	Yellow

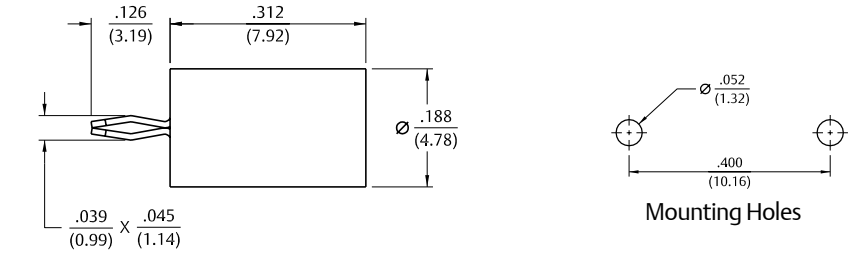

## SPECIFICATIONS

**Contact:** Beryllium copper per QQ-C-533

**Finish:** Silver

**Body:** Nylon 6/6 per ASTM D4066

## RATINGS

**Current:** 5 amps

**Breakdown Voltage:** 3500 VRMS minimum†

**Contact Resistance:** Silver: 0.010 ohms maximum

**Adjacent Jack C:** 1 pF maximum at 1 MHz

## For Standard Tip Plug:

**.080 (2.00) Diameter**

## FEATURES

- Spring loaded lead to hold in board
- Contact protected from flux and solder
- Nylon UL approved for self extinguishing

† Avoid user injury due to misapplication. See safety advisory definitions inside front cover.

## Insulated Standard



Silver Plating	
Part No.	Color
105-0751-001	White
105-0752-001	Red
105-0753-001	Black
105-0754-001	Green
105-0756-001	Orange
105-0757-001	Yellow
105-0758-001	Brown
105-0760-001	Blue
105-0762-001	Violet
105-0763-001	Gray

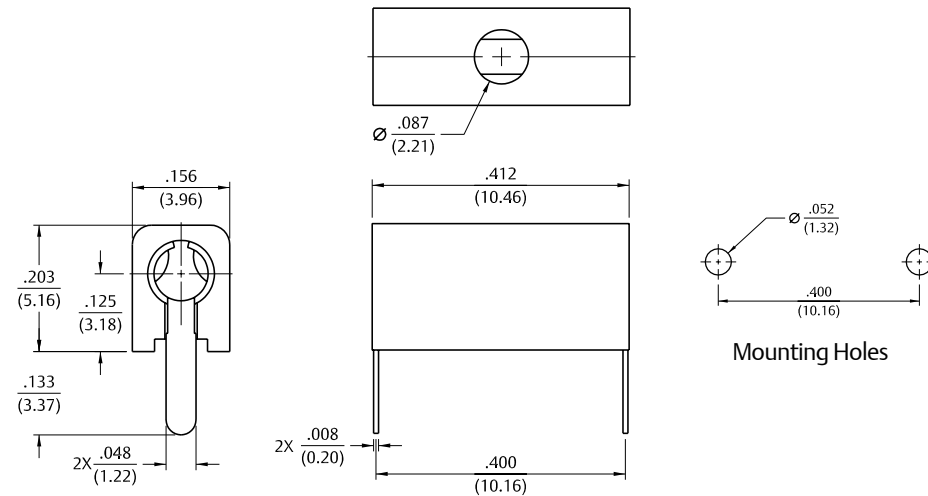

## SPECIFICATIONS

**Contact:** Copper aluminum alloy\*

**Finish:** Silver

**Body:** Nylon 6/6 per ASTM D4066

## RATINGS

**Current:** 5 amps

**Breakdown Voltage:** 2100 VRMS minimum

**Contact Resistance:** Silver: 0.010 ohms maximum

**Adjacent Jack C:** 1 pF maximum at 1 MHz

## For Standard Tip Plug:

**.080 (2.00) Diameter**

## FEATURES

- Contact protected from flux and solder
- Probe access from both ends
- Nylon UL approved for self extinguishing

\*A new material development that, for this application, meets or exceeds beryllium copper.

## Insulated Standard: Rib-Lock™ Type



Silver Plating	
Part No.	Color
105-1041-001	White
105-1042-001	Red
105-1043-001	Black

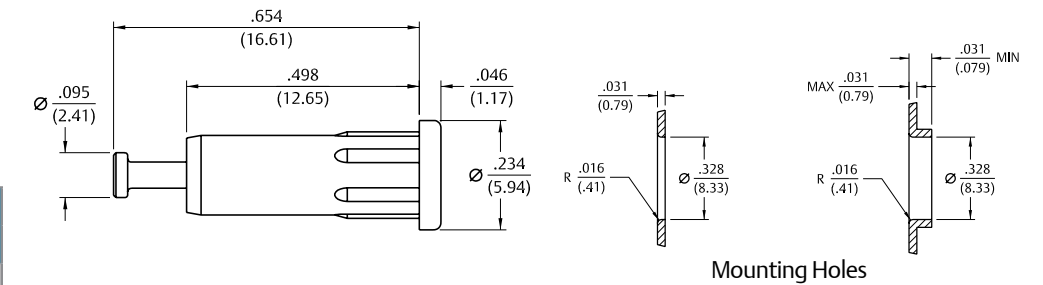

## SPECIFICATIONS

**Contact:** Brass body per QQ-B-626D with wrap around beryllium copper spring per QQ-C-533

**Finish:** Silver

**Body:** Nylon 6/6 per ASTM D4066

**Panel Thickness:** up to .375 (9.05)

## RATINGS

**Current:** 5 amps

**Breakdown Voltage:** 3500 VRMS minimum†

**Contact Resistance:** 0.005 ohms maximum

**Adjacent Jack C:** 1 pF nominal

## For Standard Tip Plug:

**.080 (2.00) Diameter**

## FEATURES

- Machined contact with turret terminal
- Installs by pressing into mounting hole, no mounting hardware required
- Closed entry blocks access or probes greater than .085 (2.16)
- Nylon UL approved for self extinguishing

† Avoid user injury due to misapplication. See safety advisory definitions inside front cover.

## Tip Jacks – For Connections to Test Equipment, Power Supplies, and Electronic Instrumentation

### Insulated Metal Clad: Military Type



#### Gold Plating Part No. to Mil-Spec. Part No. Cross Reference

Part No.	Color	Mil-C-39024/10
105-0201-200	White	-01
105-0202-200	Red	-02
105-0203-200	Black	-03

#### SPECIFICATIONS

**Contact:** Brass per QQ-B-626D with wrap around beryllium copper spring per QQ-C-533

**Finish:** Gold

**Body:** Nylon 6/6 per ASTM D4066

**Threaded Brass Jacket:** Per QQ-B-626D, nickel

**Hardware:** Nickel plated washer and nut (unassembled)

**Panel Thickness:** Up to .218 (5.45)

#### RATINGS

**Current:** 10 amps

**Breakdown Voltage:** 5700 VRMS minimum

**Contact Resistance:** 0.004 ohms maximum

**Contact-To-Panel C:** 2 pF nominal

Manufactured to meet MIL-C-39024/10

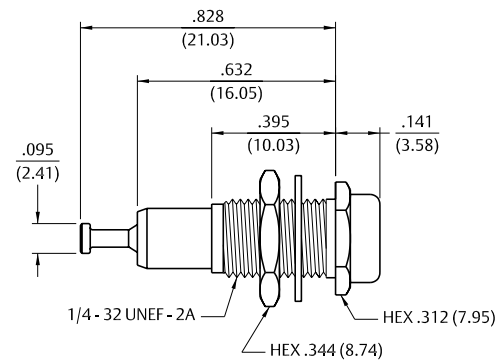

#### For Standard Tip Plug: .080 (2.00) Diameter FEATURES

- Machined contact with turret terminal
- For military or industrial applications
- Closed entry blocks access of probes greater than .085 (2.16)
- Nylon UL approved for self extinguishing

† Avoid user injury due to misapplication. See safety advisory definitions inside front cover.

### Insulated Metal Clad: Standard Type



#### Silver Plating

Part No.	Color
105-0251-001	White
105-0252-001	Red
105-0253-001	Black

#### SPECIFICATIONS

**Contact:** Phosphor bronze per QQ-B-750

**Finish:** Silver

**Body:** Nylon 6/6 per ASTM D4066

**Panel Thickness:** Up to .281 (7.10)

#### RATINGS

**Current:** 10 amps

**Breakdown Voltage:** 5700 VRMS minimum†

**Contact Resistance:** 0.010 ohms maximum

**Contact-To-Panel C:** 2 pF nominal

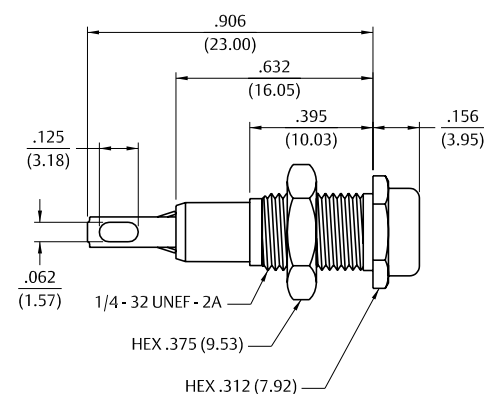

#### For Standard Tip Plug: .080 (2.00) Diameter FEATURES

- Formed contact with slotted terminal
- Nylon UL approved for self extinguishing

† Avoid user injury due to misapplication. See safety advisory definitions inside front cover.

### Insulated Deluxe



#### Silver Plating

Part No.	Color
105-0601-001	White
105-0602-001	Red
105-0603-001	Black

## Tip Jacks – For Connections to Test Equipment, Power Supplies, and Electronic Instrumentation

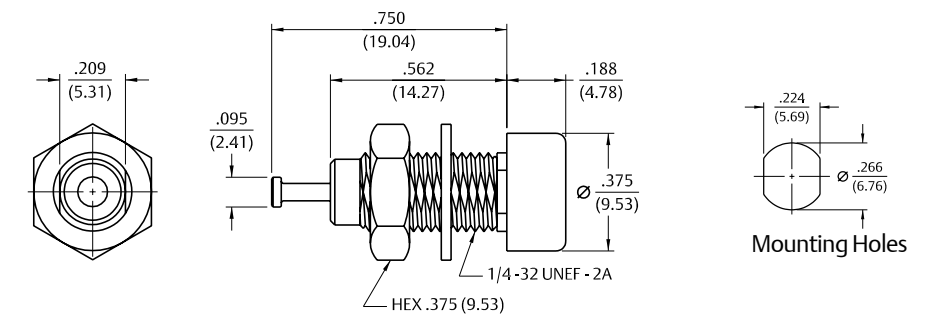

#### SPECIFICATIONS

**Contact:** Brass per QQ-B-626D with wrap around beryllium copper spring per QQ-C-533

**Finish:** Silver

**Body:** Nylon 6/6 per ASTM D4066

**Hardware:** Nickel plated nut (unassembled)

**Body Thread Stripping Torque:** 0.4 lb. in (4.5 kg cm)

**Panel Thickness:** Up to .437 (11.10)

#### RATINGS

**Current:** 10 amps

**Breakdown Voltage:** 5700 VRMS minimum†

**Contact Resistance:** 0.010 ohms maximum

**Contact-To-Panel C:** 2 pF nominal

#### For Standard Tip Plug: .080 (2.00) Diameter FEATURES

- Machined contact with turret terminal
- Hex socket head .188 (4.77) for ease in mounting
- Closed entry blocks access of probes greater than .085 (2.16)
- Nylon UL approved for self extinguishing

† Avoid user injury due to misapplication. See safety advisory definitions inside front cover.

### Insulated Standard



#### Bright Tin Plating

Part No.	Color
105-0801-001	White
105-0802-001	Red
105-0803-001	Black
105-0804-001	Green
105-0807-001	Yellow

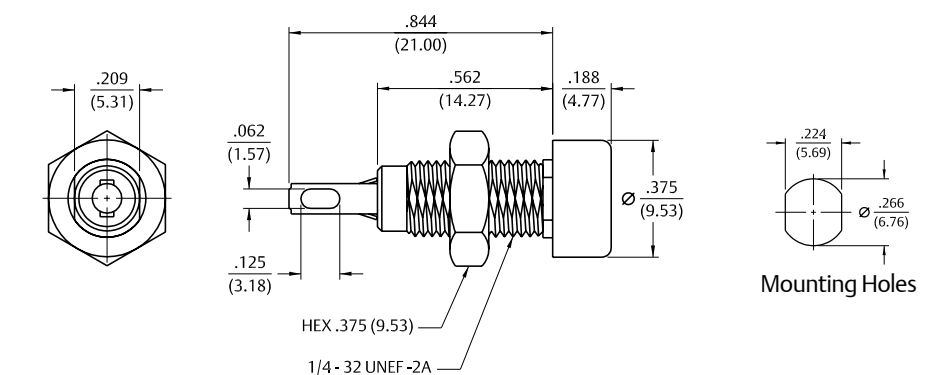

#### SPECIFICATIONS

**Contact:** Phosphor bronze per QQ-B-750

**Finish:** Bright tin

**Body:** Nylon 6/6 per ASTM D4066

**Hardware:** Nickel plated nut (unassembled)

**Body Thread Stripping Torque:** 4.0 lb. in (4.5 kg cm)

**Panel Thickness:** Up to .437 (11.10)

#### RATINGS

**Current:** 10 amps

**Breakdown Voltage:** 5700 VRMS minimum†

**Contact Resistance:** 0.010 ohms maximum

**Contact-To-Panel C:** 2 pF nominal

#### For Standard Tip Plug: .080 (2.00) Diameter FEATURES

- Formed contact with slotted terminal
- Hex socket head .188 (4.77) for ease in mounting
- Nylon UL approved for self extinguishing

† Avoid user injury due to misapplication. See safety advisory definitions inside front cover.

## Tip Jacks – For Connections to Test Equipment, Power Supplies, and Electronic Instrumentation

### Insulated Metal Clad: Military Type

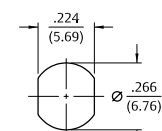
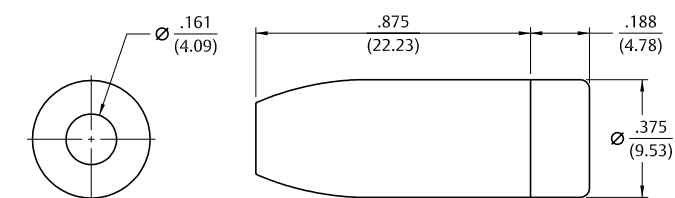

Mounting Holes

Silver Plating	
Part No.	Color
105-0701-001	White
105-0702-001	Red
105-0703-001	Black

#### SPECIFICATIONS

**Contact:** Brass per QQ-B-626D with wrap around beryllium copper spring per QQ-C-533

**Finish:** Silver

**Body:** Nylon 6/6 per ASTM D4066

**Threaded Brass Jacket:** Per QQ-B-626D, nickel

**Hardware:** Nickel plated washer and nut (unassembled)

**Panel Thickness:** Up to .218 (5.45)

#### RATINGS

**Current:** 10 amps

**Breakdown Voltage:** 5700 VRMS minimum

**Contact Resistance:** 0.004 ohms maximum

**Contact-To-Panel C:** 2 pF nominal

Manufactured to meet MIL-C-39024/10

#### For Standard Tip Plug: .080 (2.00) Diameter FEATURES

- Machined contact with turret terminal
- For military or industrial applications
- Closed entry blocks access of probes greater than .085 (2.16)
- Nylon UL approved for self extinguishing

† Avoid user injury due to misapplication. See safety advisory definitions inside front cover.

### Insulated Metal Clad: Standard Type

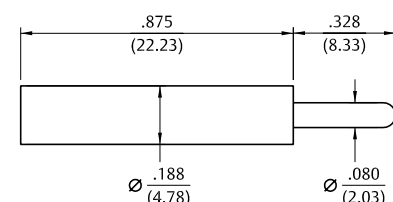
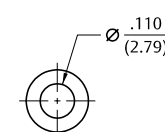

Nickel Plating	
Solder Type Up to 16 Gauge Part No.	Crimp Type 16 Gauge Plating Color
105-0771-001	White
105-0772-001	Red
105-0773-001	Black

#### SPECIFICATIONS

**Contact:** Brass per QQ-B-626D

**Finish:** Nickel

**Insulated Handle:** Nylon 6/6 per ASTM D4066

#### RATINGS

**Current:** 10 amps

**Breakdown Voltage:** 3500 VRMS minimum†

**Contact Resistance:** 0.010 ohms maximum

#### For Standard Tip Plug: .080 (2.00) Diameter FEATURES

- Solder or crimp type connection
- Accepts wire sizes up to 16 gauge
- Nylon UL approved for self extinguishing
- Designed for use with horizontal and vertical test jacks only

† Avoid user injury due to misapplication. See safety advisory definitions inside front cover.

### Insulated Deluxe



Nickel Plating	
Part No.	Color
105-0301-001	White
105-0302-001	Red
105-0303-001	Black
105-0304-001	Green
105-0310-001	Blue

## Tip Plugs & Banana Jacks – For Connections to Monitoring Equipment

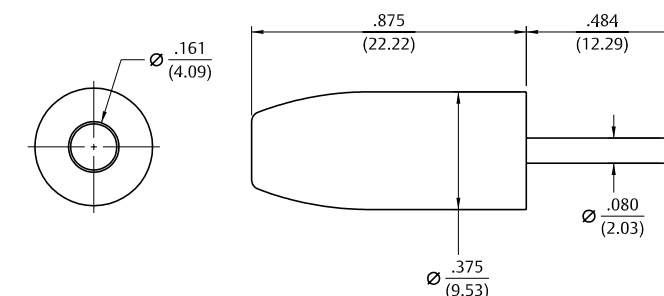

#### SPECIFICATIONS

**Contact:** Brass per QQ-B-626D

**Finish:** Nickel

**Insulated Handle:** Nylon 6/6 per ASTM D4066

#### RATINGS

**Current:** 10 amps

**Breakdown Voltage:** 3500 VRMS minimum†

**Contact Resistance:** 0.010 ohms maximum

#### For Standard Tip Plug: .080 (2.00) Diameter FEATURES

- Recessed head to reduce shock hazard
- Accepts wire sizes up to 16 gauge
- Nylon UL approved for self extinguishing

† Avoid user injury due to misapplication. See safety advisory definitions inside front cover.

### Insulated Standard



Nickel Plating	
Part No.	Color
108-0740-001	Nickel

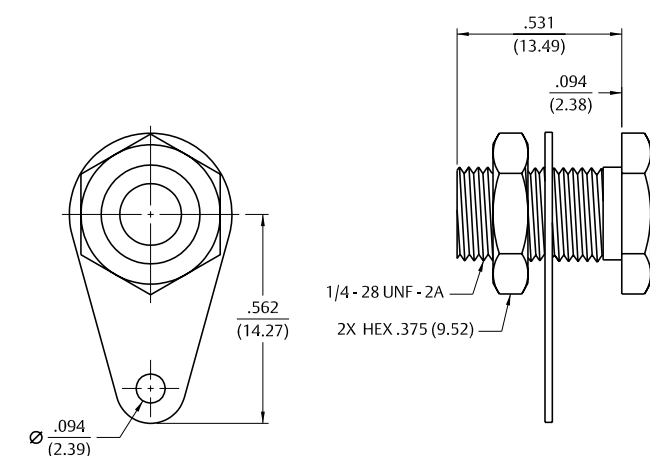

#### SPECIFICATIONS

**Jack Body:** Brass per QQ-B-626D

**Finish:** Nickel

**Hardware:** Nickel plated nut; stamped tin plated solder terminal (unassembled)

**Panel Thickness:** Up to .375 (9.50)

#### RATINGS

**Current:** 15 amps

**Contact Resistance:** 0.010 ohms maximum

#### For Standard Banana Plug: .175 (4.44) Across Flats FEATURES

- Accepts up to 12 gauge wire
- Hex head for faster installation
- For higher current designs

For more information, please contact customer service at (507) 833-8822 or (800) 247-8256 • [www.EmersonConnectivity.com](http://www.EmersonConnectivity.com)

Illustrations are shown in inches (millimeters).

# Banana Jacks – For Test Equipment and Power Supplies

## Uninsulated Standard Type: Slotted Lug Terminal



Nickel Plating	
Part No.	Color
108-0740-102	Nickel

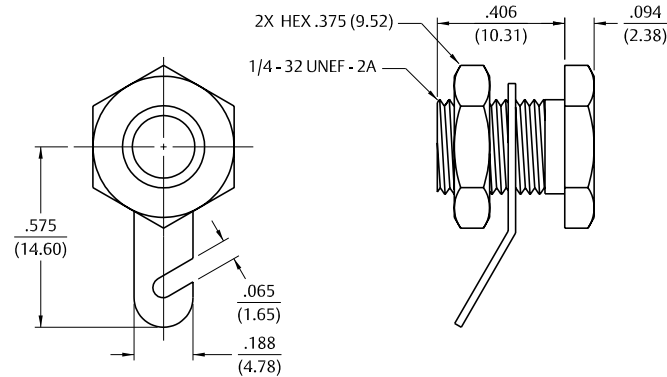

### SPECIFICATIONS

**Jack Body:** Brass per QQ-B-626D  
**Finish:** Nickel  
**Hardware:** Nickel plated nut; stamped tin plated solder terminal (unassembled)  
**Panel Thickness:** Up to .250 (6.35)

### RATINGS

**Current:** 15 amps  
**Contact Resistance:** 0.010 ohms maximum

**For Standard Banana Plug:**  
**.175 (4.44) Across Flats**  
**FEATURES**

- Accepts up to 12 gauge wire
- Hex head for faster installation
- For higher current designs

## Insulated Rib-Loc™ Solder Terminal



Bright Tin Plating	
Part No.	Color
108-2301-801	White
108-2302-801	Red
108-2303-801	Black
108-2307-801	Yellow
108-2310-801	Blue

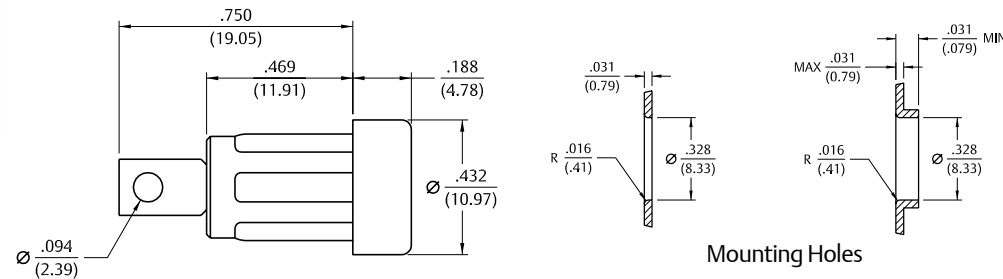

### SPECIFICATIONS

**Contact:** Formed brass per QQ-B-626D  
**Finish:** Bright Tin  
**Body:** Nylon 6/6 per ASTM D4066  
**Panel Thickness:** Up to .250 (6.35)

### RATINGS

**Current:** 15 amps  
**Breakdown Voltage:** 7000 VRMS minimum†  
**Contact Resistance:** 0.010 ohms maximum  
**Contact-To-Panel C:** 2.4 pF nominal

**For Standard Banana Plug:**  
**.175 (4.44) Across Flats**  
**FEATURES**

- Requires no mounting hardware
- Accepts up to 16 gauge wire
- Nylon UL approved for self extinguishing

† Avoid user injury due to misapplication. See safety advisory definitions inside front cover.

# Banana Jacks – For Test Equipment and Power Supplies

## Insulated Turret Terminal



Silver Plating	
Part No.	Color
108-2302-621	Red
108-2303-621	Black

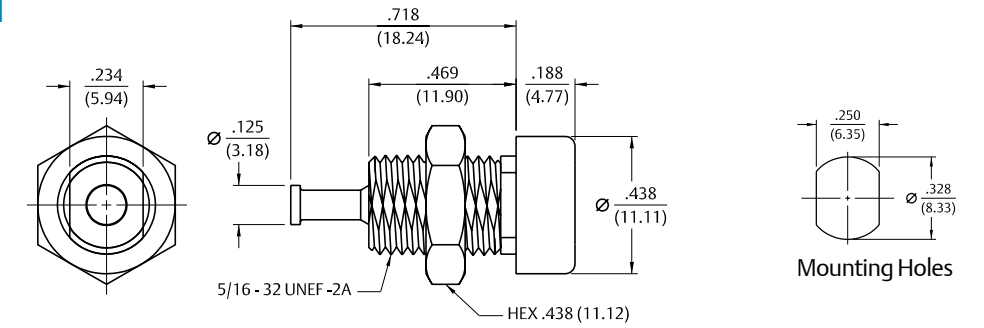

### SPECIFICATIONS

**Contact:** Machined brass per QQ-B-626D  
**Finish:** Silver  
**Body:** Nylon 6/6 per ASTM D4066  
**Hardware:** Nickel plated nut (unassembled)  
**Body Thread Stripping Torque:** 6.0 lb. in. (7 kg cm)  
**Panel Thickness:** Up to .343 (8.80)

### RATINGS

**Current:** 15 amps  
**Breakdown Voltage:** 7000 VRMS minimum  
**Contact Resistance:** 0.010 ohms maximum  
**Contact-To-Panel:** 2.4 pF nominal

**For Standard Banana Plug:**  
**.175 (4.44) Across Flat**  
**FEATURES**

- Keyed mounting with double flats
- Nylon UL approved for self extinguishing

## Insulated Solder Terminal



Bright Tin Plating	
Part No.	Color
108-0901-001	White
108-0902-001	Red
108-0903-001	Black
108-0904-001	Green
108-0906-001	Orange
108-0907-001	Yellow
108-0908-001	Brown
108-0910-001	Blue
108-0912-001	Violet
108-0913-001	Gray

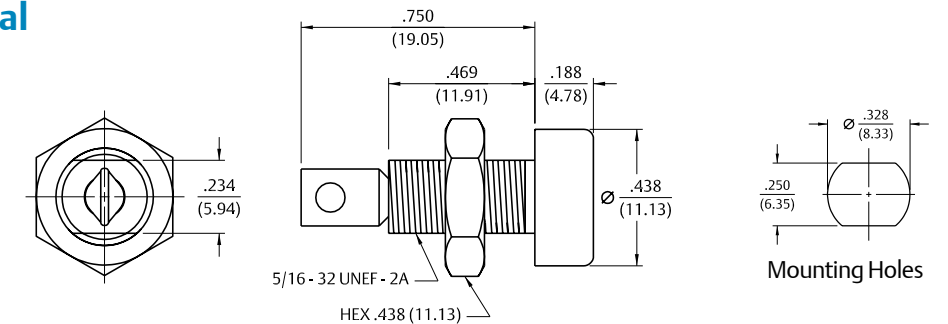

### SPECIFICATIONS

**Jack Body:** Formed brass per QQ-B-626D  
**Finish:** Bright tin  
**Body:** Nylon 6/6 per ASTM D4066  
**Hardware:** Nickel plated nut (unassembled)  
**Body Thread Stripping Torque:** 6.0 lb. in. (7 kg cm)  
**Panel Thickness:** Up to .343 (8.80)

### RATINGS

**Current:** 15 amps  
**Breakdown Voltage:** 7000 VRMS minimum†  
**Contact Resistance:** 0.010 ohms maximum  
**Contact-To-Panel:** 2.4 pF nominal

**For Standard Banana Plug:**  
**.175 (4.44) Across Flats**  
**FEATURES**

- Accepts up to 12 gauge wire
- Hex head for faster installation
- For higher current designs

† Avoid user injury due to misapplication. See safety advisory definitions inside front cover.

# Banana Jacks & Plugs – For Test Equipment and Power Supplies

## Insulated Pierced Lug Terminal



Nickel Plating	
Part No.	Color
108-0745-001	Red
108-0745-002	Black

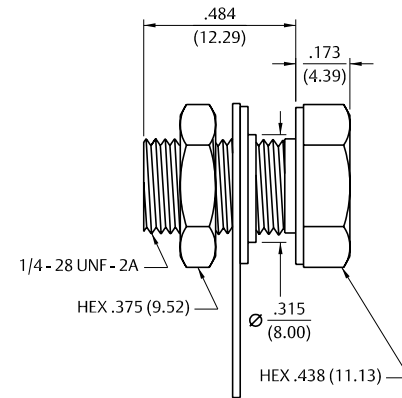
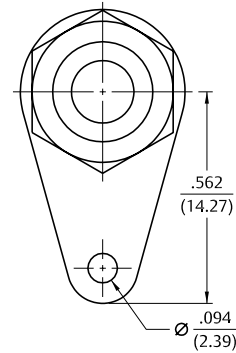

**For Standard Banana Plug:**  
**.175 (4.44) Across Flats**  
**FEATURES**

- Withstands extreme temperatures and abuse
- Stamped tin plated solder terminal with hole for up to 12 gauge wire
- Integrally molded hex head for fast installation

† Avoid user injury due to misapplication. See safety advisory definitions inside front cover.

### SPECIFICATIONS

**Contact:** Brass per QQ-B-626D  
**Finish:** Nickel  
**Hex Head:** Molded phenolic  
**Hardware:** Nickel plated nut, fiber insulating washer and stamped tin plated solder terminal (unassembled)  
**Panel Thickness:** Up to .281 (7.15)

### RATINGS

**Current:** 15 amps  
**Breakdown Voltage:** 1500 VRMS minimum†  
**Contact Resistance:** 0.010 ohms maximum  
**Contact-To-Panel:** 2.4 pF nominal

## Uninsulated Rivet Type



Silver Plating	
Part No.	Color
108-0754-001	Silver

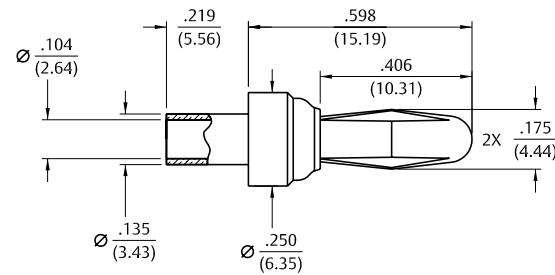

### SPECIFICATIONS

**Plug Body:** Brass per QQ-B-626D  
**Plug Spring:** Beryllium copper per QQ-C-533  
**Finish:** Silver  
**Panel Thickness:** Up to .156 (4.00)

### RATINGS

**Current:** 15 amps  
**Contact Resistance:** 0.010 ohms maximum

**For Standard Banana Plug:**  
**.166 (4.23) Diameter**  
**FEATURES**

- Shorter spring adapts to standard jack or special size jack
- Ideal for limited space applications

# Banana Plugs – For Test Equipment and Power Supplies

## Uninsulated Panel Mount Threaded Stud



Nickel Plating	
Part No.	Stud Length "A"
108-0750-001	.375 (9.50)
108-0750-002	.750 (19.05)

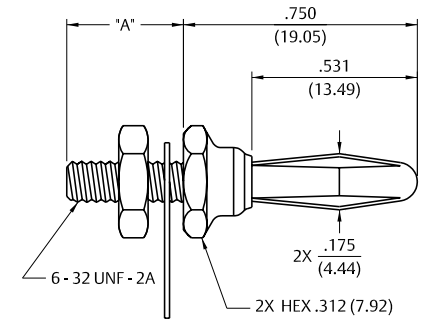
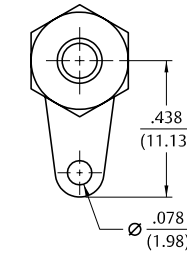

### SPECIFICATIONS

**Plug Body:** Brass per QQ-B-626D  
**Plug Spring:** Nickel silver per QQ-C-585  
**Finish:** Nickel  
**Panel Thickness:** Up to .25 (6.35) .625 (16.00)  
**Hardware:** Nickel plated nut, stamped tin plated solder terminal (unassembled)

### RATINGS

**Current:** 15 amps  
**Contact Resistance:** 0.010 ohms maximum

**For Standard Banana Plug:**  
**.166 (4.23) Diameter**  
**FEATURES**

- Pierced hole for up to 14 gauge wires

## Uninsulated Panel Mount Screw Type Beryllium Copper Spring



Nickel Plating				
Part No.	Body Length		Panel Thickness	
	A	B	A	B
108-0753-102	906 (32.01)	562 (14.27)	.156 max	.125 max

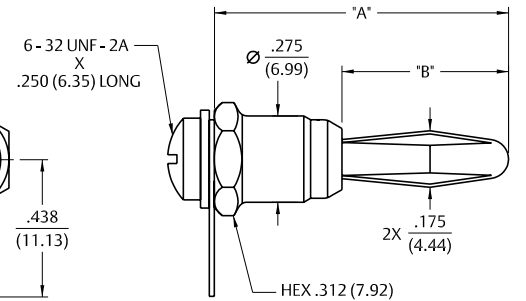
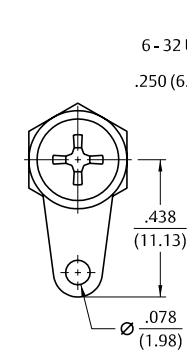

### SPECIFICATIONS

**Plug Body:** Brass per QQ-B-626D  
**Plug Spring:** Beryllium copper per QQ-C-533  
**Finish:** Nickel  
**Panel Thickness:** Up to .156 (4.00)  
**Hardware:** Nickel plated nut, stamped tin plated solder terminal (unassembled)

### RATINGS

**Current:** 15 amps  
**Contact Resistance:** 0.010 ohms maximum

**For Standard Banana Plug:**  
**.166 (4.23) Diameter**  
**FEATURES**

- Rugged screw type
- Stamped tin plated solder terminal with hole for up to 14 gauge wire

## Banana Plugs – For Test Equipment and Power Supplies

## Insulated Solderless Tapered Handle

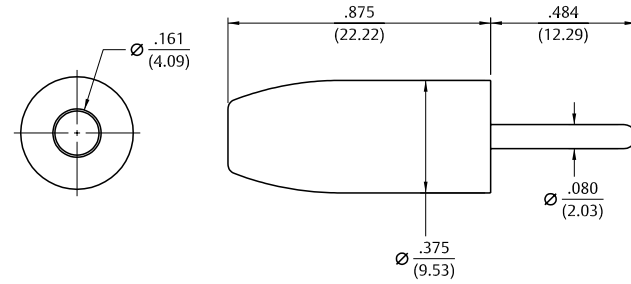

Nickel Plating	
Part No.	Color
108-0301-001	White
108-0302-001	Red
108-0303-001	Black
108-0304-001	Green
108-0306-001	Orange
108-0307-001	Yellow
108-0308-001	Brown
108-0310-001	Blue
108-0312-001	Violet
108-0313-001	Gray

## SPECIFICATIONS

**Plug Body:** Brass per QQ-B-626D  
**Plug Spring:** Nickel silver per QQ-C-533  
**Finish:** Nickel  
**Insulated Handle:** Nylon 6/6 per ASTM D4066

**Panel Thickness:** Up to .281 (7.15)

## RATINGS

**Current:** 15 amps  
**Breakdown Voltage:** 3500 VRMS minimum†  
**Contact Resistance:** 0.010 ohms maximum

For Standard Banana Plug:  
.166 (4.23) Diameter

## FEATURES

- Fast solderless connection of up to 16 gauge wire
- Recessed plug body to limit shock hazard
- Nylon UL approved for self extinguishing

† Avoid user injury due to misapplication. See safety advisory definitions inside front cover.

## Insulated Side Set Screw Solderless

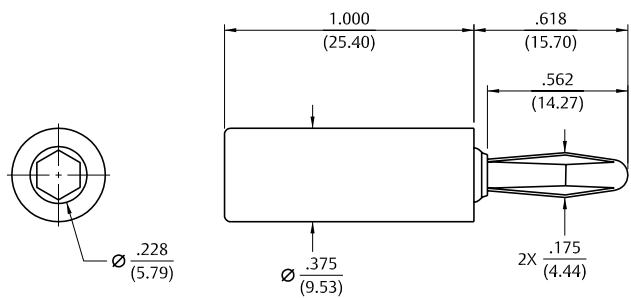

Nickel Plating	
Part No.	Color
108-1702-101	Red
108-1703-101	Black

## SPECIFICATIONS

**Plug Body:** Brass per QQ-B-626D  
**Plug Spring:** Nickel silver per QQ-C-585  
**Finish:** Nickel  
**Insulated Handle:** Nylon 6/6 per ASTM D4066

## RATINGS

**Current:** 15 amps  
**Breakdown Voltage:** 35 VRMS minimum†

For Standard Banana Plug:  
.166 (4.23) Diameter For Low Voltage (50 WVDC) Applications

## FEATURES

- Fast solderless connection of up to 16 gauge wire
- Set screw for dependable connections with low voltage
- Nylon UL approved for self extinguishing

† Avoid user injury due to misapplication. See safety advisory definitions inside front cover.

## Banana Plugs – For Test Equipment and Power Supplies

## Insulated Hex Body Solder Stud

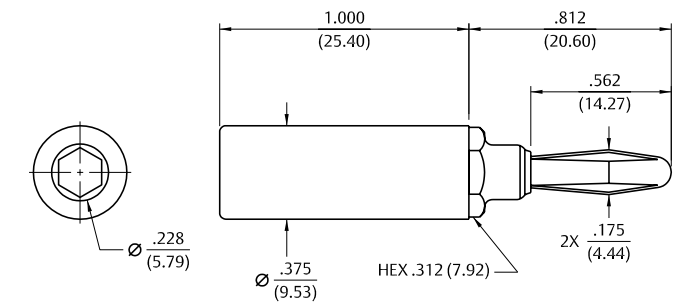

Nickel Plating	
Part No.	Color
108-1762-101	Red
108-1763-101	Black

## SPECIFICATIONS

**Plug Body:** Brass per QQ-B-626D  
**Plug Spring:** Nickel silver per QQ-C-585  
**Finish:** Nickel  
**Insulated Handle:** Nylon 6/6 per ASTM D4066

## RATINGS

**Current:** 15 amps  
**Breakdown Voltage:** 3500 VRMS minimum†  
**Contact Resistance:** 0.010 ohms maximum

For Standard Banana Plug:  
.166 (4.23) Diameter

## FEATURES

- Wire can be soldered to threaded stud
- Solder stud accepts up to 16 gauge wire
- Nylon UL approved for self extinguishing

† Avoid user injury due to misapplication. See safety advisory definitions inside front cover.

## Insulated Round Body Solder Stud

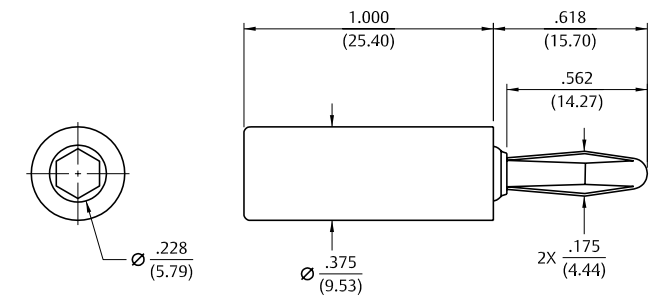

Nickel Plating	
Part No.	Color
108-1722-101	Red
108-1723-101	Black

## SPECIFICATIONS

**Plug Body:** Brass per QQ-B-626D  
**Plug Spring:** Nickel silver per QQ-C-585  
**Finish:** Nickel  
**Insulated Handle:** Nylon 6/6 per ASTM D4066

## RATINGS

**Current:** 15 amps  
**Breakdown Voltage:** 3500 VRMS minimum†

For Standard Banana Plug:  
.166 (4.23) Diameter

## FEATURES

- Wire can be soldered to threaded stud
- Solder stud accepts up to 16 gauge wire
- Nylon UL approved for self extinguishing

† Avoid user injury due to misapplication. See safety advisory definitions inside front cover.

# Banana Plugs – For Test Equipment and Power Supplies

## Insulated Stacking Single Type



Nickel Plating	
Part No.	Color
108-1081-001	White
108-1082-001	Red
108-1083-001	Black
108-1087-001	Yellow

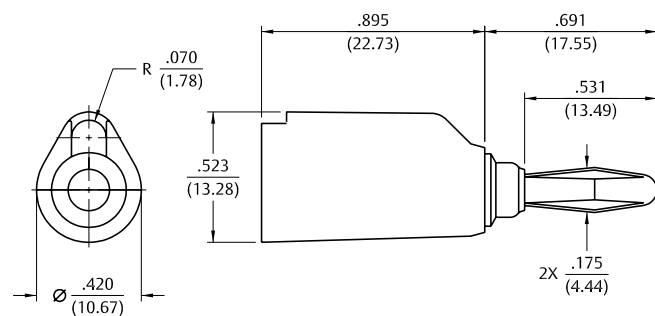

### SPECIFICATIONS

**Plug Body:** Brass per QQ-B-626D  
**Plug Spring:** Nickel silver per QQ-C-585  
**Finish:** Nickel  
**Insulated Handle:** Nylon 6/6 per ASTM D4066

**Panel Thickness:** Up to .281 (7.15)

### RATINGS

**Current:** 15 amps  
**Breakdown Voltage:** 3500 VRMS minimum†  
**Contact Resistance:** 0.010 ohms maximum

### For Standard Banana Plug:

**.166 (4.23) Diameter**

### FEATURES

- Wire can be soldered to threaded stud
- Solder stud accepts up to 16 gauge wire
- Nylon UL approved for self extinguishing

† Avoid user injury due to misapplication. See safety advisory definitions inside front cover.

## Insulated Stacking Dual Type



Nickel Plating Set Screw (Accepts Wire Sizes Up To 14 Gauge)	
Part No.	Color
108-0252-001	Red
108-0253-001	Black

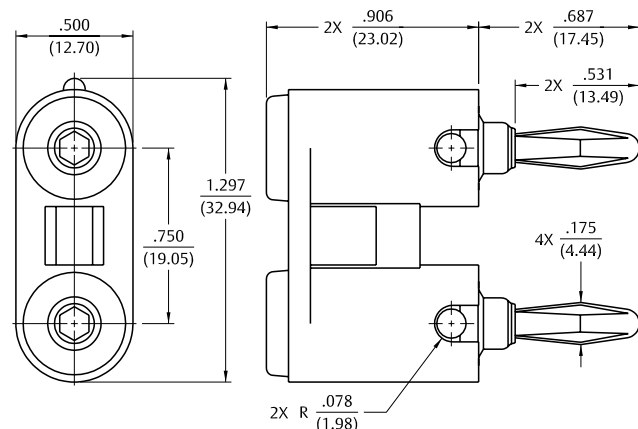

### SPECIFICATIONS

**Plug Body:** Brass per QQ-B-626D  
**Plug Spring:** Nickel silver per QQ-C-586  
**Finish:** Nickel  
**Insulated Handle:** Nylon 6/6 per ASTM D4066

### RATINGS

**Current:** 15 amps  
**Breakdown Voltage:** 3500 VRMS minimum†  
**Contact Resistance:** 0.010 ohms maximum

### For Standard Banana Plug:

**.166 (4.23) Diameter**

### FEATURES

- Accepts standard banana plug from rear
- Built-in strain relief for long life
- Nylon UL approved for self extinguishing

† Avoid user injury due to misapplication. See safety advisory definitions inside front cover.

# Banana Plugs – For Audio Circuitry and RF Circuitry

## Insulated Solder Type



Nickel Plating	
Part No.	Color
108-1002-001	Red
108-1003-001	Black

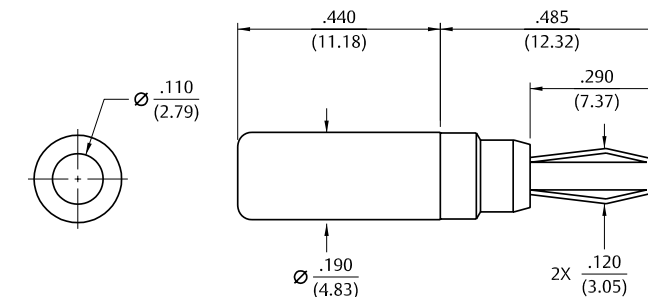

### SPECIFICATIONS

**Plug Body:** Brass per QQ-B-626D  
**Plug Spring:** Beryllium copper per QQ-C-533  
**Finish:** Nickel  
**Insulated Handle:** Nylon 6/6 per ASTM D4066

### RATINGS

**Current:** 10 amps  
**Breakdown Voltage:** 3500 VRMS minimum†  
**Contact Resistance:** 0.010 ohms maximum

### For Miniature Banana Jack:

**.104 (2.64) Diameter**

### FEATURES

- Wire can be soldered to threaded stud
- Solder stud accepts up to 16 gauge wire
- Nylon UL approved for self extinguishing

† Avoid user injury due to misapplication. See safety advisory definitions inside front cover.

## Uninsulated With Knurled Thumb-Nut-Grounded Type



Nickel Plating	
Part No.	Color
111-2223-001	Nickel

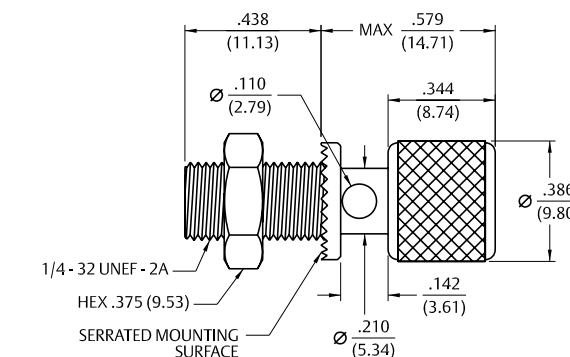

### SPECIFICATIONS

**Stud:** Brass per QQ-B-626D  
**Finish:** Nickel  
**Hardware:** Nickel plated nut (unassembled)  
**Panel Thickness:** Up to .281 (7.15)

### RATINGS

**Current:** 15 amps

### For Standard Banana Plug:

**.175 (4.44) Across Flats**

### FEATURES

- Nickel plated stud with serrated mounting surface prevents turning
- Captive thumb nut .110 (2.79) diameter cross-hole accommodates up to 10 gauge wire



## Binding Posts – For Audio Circuitry and RF Circuitry

## Insulated Standard



Silver Plating	
Part No.	Color
111-0101-001	White
111-0102-001	Red
111-0104-001	Green
111-0103-001	Black
111-0107-001	Yellow
111-0110-001	Blue

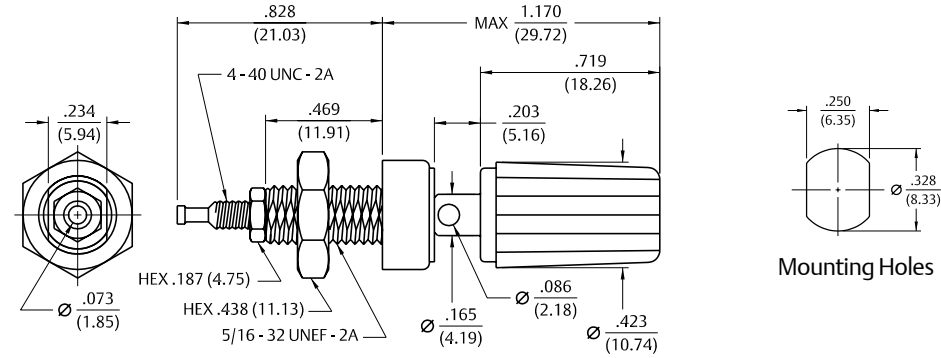

## SPECIFICATIONS

**Stud:** Brass per QQ-B-626D**Finish:** Silver**Insulating Material:** Nylon 6/6 per ASTM D4066**Hardware:** Nickel plated nut (unassembled)**Body Thread Stripping Torque:** 6.0 lb. in. (7.0 kg cm)**Panel Thickness:** Up to .281 (7.15)

## RATINGS

**Current:** 15 amps**Contact Resistance:** 0.010 ohms maximum**Breakdown Voltage:** 5700 VRMS minimum†**Stud-To-Panel:** 3.3 pF nominal

## For Standard Banana Plug:

**.175 (4.44) Diameter**

## FEATURES

- Turret terminal
- Captive thumb nut
- Insulated body is flatted to prevent turning
- Nylon UL approved for self-extinguishing

† Avoid user injury due to misapplication. See safety advisory definitions inside front cover.

## Insulated Standard With – Thumb Nut – Grounded Type



Nickel Plating	
Part No.	Color
111-0702-001	Red
111-0703-001	Black

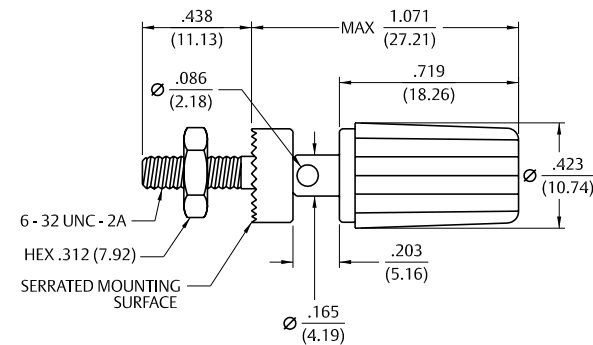

## SPECIFICATIONS

**Stud:** Brass per QQ-B-626D**Finish:** Nickel**Insulating Material:** Nylon 6/6 per ASTM D4066**Hardware:** Nickel plated nut (unassembled)**Panel Thickness:** Up to .313 (7.95)

## RATINGS

**Current:** 15 amps

## For Standard Banana Plug:

**.166 (4.23) Diameter**

## FEATURES

- Accepts standard banana plug from rear
- Built-in strain relief for long life
- Nylon UL approved for self-extinguishing

† Avoid user injury due to misapplication. See safety advisory definitions inside front cover.

## Assembly Tools and Fixtures

273

## Assembly Tools and Fixtures (108-108X-001 Series)



Fixture Part No.	Tool Part No.
251-0111-003	251-0115-002

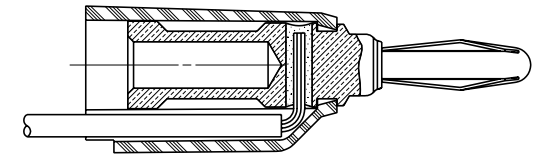

## For Standard Stacking Banana Plugs: .175 (4.44) Across Flats

Quick and easy assembly of standard banana plug .175 (4.44) diameter is possible with the assembly tool and fixtures shown here. Strip wire jacket back 3/4" and feed wire through cross hole of metal contact. Fold stripped wire against metal plug body and slide insulated handle over banana plug body and wires. Insert contact wire into housing. Place into fixture. Push tip of tool into rear of contact. Snap contact into place. Handle of tool is curved to fit hand comfortably. Fixture and tip of tool made from tool steel.

## Crimp Tool (105-077X-XXX Series)



Tool Part No.	MIL Part No.
144-0000-910	M22520/1-01

## For Insulated Standard Small Handle Tip Plugs: .080 (2.00) Diameter and .060 (1.50) Tip Jacks

Quick and easy assembly of standard banana plug .175 (4.44) diameter is possible with the assembly tool and fixtures shown here. Strip wire jacket back 3/4" and feed wire through cross hole of metal contact. Fold stripped wire against metal plug body and slide insulated handle over banana plug body and wires. Insert contact wire into housing. Place into fixture. Push tip of tool into rear of contact. Snap contact into place. Handle of tool is curved to fit hand comfortably. Fixture and tip of tool made from tool steel.

**Part Number and Competitor Cross-Reference Index**

Other Information  
 Assembly Tools.....185  
 Capabilities.....190  
 Cable Information.....192  
 Assembly Instruction.....193  
 Mounting Hole Layouts .....194  
     Numerical Index.....274  
 Competitor Cross Reference..... 280

**3 MMCX Connectors**

**13 MCX Connectors**

**39 SMK Connectors**

**45 SMA Connectors**

**103 SMB Connectors**

**131 SMC Connectors**

**137 SMP Connectors**

**145 Type N Connectors**

**153 Shielded Cable Terminations**

**157 Between-Series Adapters**

**161 Fixed Length Cable Assemblies**

**173 Ultra Miniature Connectors (UMC)**

**181 kwiQMate™ Connectors**

**185 Tools**

**193 Assembly Instructions**

**257 Electronic Hardware**

**274 Index**

105-0201-200.....260	108-2301-801.....264	131-3303-501.....239	131-3701-301.....113	131-6701-406.....136
105-0202-200.....260	108-2302-621.....265	131-3303-506.....110	131-3701-306.....113	131-6701-411.....136
105-0203-200.....260	108-2302-801.....264	131-3303-506.....239	131-3701-341.....114	131-6701-416.....136
105-0251-001.....260	108-2303-621.....265	131-3304-401.....110	131-3701-346.....114	131-6701-831.....136
105-0252-001.....260	108-2303-801.....264	131-3304-401.....238	131-3701-401.....115	131-6701-836.....136
105-0253-001.....260	108-2307-801.....264	131-3304-406.....110	131-3701-406.....115	131-6711-201.....135
105-0301-001.....263	108-2310-801.....264	131-3304-406.....238	131-3701-411.....115	131-8303-401.....123
105-0302-001.....263	111-0101-001.....272	131-3304-501.....110	131-3701-416.....115	131-8303-401.....238
105-0303-001.....263	111-0102-001.....272	131-3304-501.....239	131-3701-441.....115	131-8303-406.....123
105-0304-001.....263	111-0103-001.....272	131-3304-506.....110	131-3701-446.....115	131-8303-406.....238
105-0310-001.....263	111-0104-001.....272	131-3304-506.....239	131-3701-501.....114	131-8304-401.....123
105-0601-001.....261	111-0107-001.....272	131-3402-001.....108	131-3701-506.....114	131-8304-401.....238
105-0602-001.....261	111-0110-001.....272	131-3402-001.....238	131-3701-511.....114	131-8304-406.....123
105-0603-001.....261	111-0702-001.....272	131-3402-016.....108	131-3701-516.....114	131-8304-406.....238
105-0701-001.....262	111-0703-001.....272	131-3402-016.....238	131-3701-621.....115	131-8403-001.....123
105-0702-001.....262	111-2223-001.....271	131-3402-101.....109	131-3701-626.....115	131-8403-001.....238
105-0703-001.....262	127-0692-001.....142	131-3402-101.....239	131-3701-631.....115	131-8403-006.....123
105-0751-001.....258	127-0692-101.....142	131-3402-116.....109	131-3701-636.....115	131-8403-006.....238
105-0752-001.....258	127-0693-001.....142	131-3402-116.....239	131-3701-801.....114	131-8403-011.....123
105-0753-001.....258	127-0693-101.....142	131-3403-001.....108	131-3701-806.....114	131-8403-011.....238
105-0754-001.....258	127-0701-201.....142	131-3403-001.....238	131-3701-811.....114	131-8403-016.....123
105-0756-001.....258	127-0701-602.....143	131-3403-016.....108	131-3701-816.....114	131-8403-016.....238
105-0757-001.....258	127-0701-612.....144	131-3403-016.....238	131-3701-821.....114	131-8403-101.....124
105-0758-001.....258	127-0701-801.....143	131-3403-021.....108	131-3701-826.....114	131-8403-101.....239
105-0760-001.....258	127-0701-802.....143	131-3403-021.....232	131-3701-831.....114	131-8403-106.....124
105-0762-001.....258	127-0711-601.....144	131-3403-026.....108	131-3701-836.....114	131-8403-106.....239
105-0763-001.....258	127-0901-801.....144	131-3403-026.....232	131-3711-201.....113	131-8403-111.....124
105-0771-001.....262	127-0901-811.....144	131-3403-101.....109	131-3711-301.....114	131-8403-111.....239
105-0772-001.....262	127-0901-821.....144	131-3403-101.....239	131-3711-302.....114	131-8403-116.....124
105-0773-001.....262	127-1701-201.....142	131-3403-116.....109	131-3801-201.....111	131-8403-116.....239
105-0801-001.....261	127-1701-602.....143	131-3403-116.....239	131-3801-216.....111	131-8404-001.....123
105-0802-001.....261	127-1701-612.....144	131-3403-401.....108	131-3801-231.....111	131-8404-001.....238
105-0803-001.....261	127-1701-801.....143	131-3403-401.....238	131-3801-236.....111	131-8404-006.....123
105-0804-001.....261	127-1701-802.....143	131-3403-406.....108	131-3801-301.....111	131-8404-006.....238
105-0807-001.....261	127-1711-601.....144	131-3403-406.....238	131-3801-316.....111	131-8404-011.....123
105-1041-001.....259	127-1901-821.....144	131-3404-001.....108	131-3801-811.....116	131-8404-011.....238
105-1042-001.....259	127-2701-201.....142	131-3404-001.....238	131-3801-816.....116	131-8404-016.....123
105-1043-001.....259	127-2701-602.....143	131-3404-016.....108	131-3801-821.....116	131-8404-016.....238
105-1101-001.....258	127-2701-612.....144	131-3404-016.....238	131-3801-826.....116	131-8404-101.....124
105-1102-001.....258	127-2701-801.....143	131-3404-021.....108	131-3901-401.....116	131-8404-101.....239
105-1103-001.....258	127-2701-802.....143	131-3404-021.....232	131-3901-406.....116	131-8404-106.....124
105-1104-001.....258	127-2711-601.....144	131-3404-026.....108	131-3901-411.....116	131-8404-106.....239
105-1107-001.....258	127-2901-821.....144	131-3404-026.....232	131-3901-416.....116	131-8404-111.....124
105-2201-201.....259	127-3701-201.....142	131-3404-101.....109	131-6303-401.....134	131-8404-111.....239
105-2202-201.....259	127-3701-602.....143	131-3404-101.....239	131-6303-401.....238	131-8404-116.....124
105-2203-201.....259	128-0000-901.....180	131-3404-116.....109	131-6303-406.....134	131-8404-116.....239
105-2204-201.....259	128-0711-201.....179	131-3404-116.....239	131-6303-406.....238	131-8409-001.....123
105-2207-201.....259	128-0711-202.....179	131-3404-401.....108	131-6304-401.....134	131-8409-001.....238
108-0252-001.....270	129-0701-301.....156	131-3404-401.....238	131-6304-401.....238	131-8409-006.....123
108-0253-001.....270	129-0701-302.....156	131-3404-406.....108	131-6304-406.....134	131-8409-006.....238
108-0301-001.....268	131-1402-101.....109	131-3404-406.....238	131-6304-406.....238	131-8409-101.....124
108-0302-001.....268	131-1402-101.....239	131-3407-001.....108	131-6333-401.....134	131-8409-101.....239
108-0303-001.....268	131-1402-116.....109	131-3407-001.....238	131-6333-401.....238	131-8409-106.....124
108-0304-001.....268	131-1402-116.....239	131-3407-006.....108	131-6333-406.....134	131-8409-106.....239
108-0306-001.....268	131-1403-001.....108	131-3407-006.....238	131-6333-406.....238	131-8433-001.....123
108-0307-001.....268	131-1403-001.....238	131-3407-011.....108	131-6403-001.....134	131-8433-001.....232
108-0308-001.....268	131-1403-016.....108	131-3407-011.....232	131-6403-001.....238	131-8433-006.....123
108-0310-001.....268	131-1403-016.....238	131-3407-016.....108	131-6403-006.....134	131-8433-006.....232
108-0312-001.....268	131-1403-101.....109	131-3407-016.....232	131-6403-006.....238	131-8434-001.....123
108-0740-001.....263	131-1403-101.....239	131-3407-101.....109	131-6403-101.....134	131-8434-001.....232
108-0740-102.....264	131-1403-116.....109	131-3407-101.....239	131-6403-101.....239	131-8434-006.....123
108-0745-001.....266	131-1403-116.....239	131-3407-106.....109	131-6403-106.....142	131-8434-006.....232
108-0745-002.....266	131-1404-001.....108	131-3407-106.....239	131-6403-106.....239	131-8445-001.....123
108-0750-001.....267	131-1404-001.....238	131-3593-401.....107	131-6404-001.....134	131-8445-001.....238
108-0750-002.....267	131-1404-016.....108	131-3593-401.....233	131-6404-001.....238	131-8445-006.....123
108-0753-102.....267	131-1404-016.....238	131-3593-406.....107	131-6404-006.....134	131-8445-006.....238
108-0754-001.....266	131-1404-101.....109	131-3593-406.....233	131-6404-006.....238	131-8445-011.....123
108-0901-001.....265	131-1404-101.....239	131-3693-001.....107	131-6404-101.....134	131-8445-011.....232
108-0902-001.....265	131-1404-116.....109	131-3693-001.....233	131-6404-101.....239	131-8445-016.....123
108-0903-001.....265	131-1404-116.....239	131-3693-016.....107	131-6404-106.....134	131-8445-016.....232
108-0904-001.....265	131-1693-101.....234	131-3693-016.....233	131-6404-106.....239	131-8445-101.....124
108-0906-001.....265	131-1693-116.....234	131-3693-101.....107	131-6433-001.....134	131-8445-101.....239
108-0907-001.....265	131-1701-371.....113	131-3693-101.....234	131-6433-001.....238	131-8445-106.....124
108-0908-001.....265	131-1701-376.....113	131-3693-116.....107	131-6433-006.....134	131-8445-106.....239
108-0910-001.....265	131-1801-371.....111	131-3693-116.....234	131-6433-006.....238	131-8701-201.....125
108-0912-001.....265	131-1801-376.....111	131-3694-401.....107	131-6433-101.....134	131-8701-206.....125
108-0913-001.....265	131-3302-001.....110	131-3694-401.....233	131-6433-101.....239	131-8701-211.....125
108-1002-001.....271	131-3302-001.....238	131-3694-406.....107	131-6433-106.....134	131-8701-216.....125
108-1003-001.....271	131-3302-006.....110	131-3694-406.....233	131-6433-106.....239	131-8701-251.....125
108-1081-001.....270	131-3302-006.....238	131-3701-201.....112	131-6593-401.....134	131-8701-256.....125
108-1082-001.....270	131-3303-001.....110	131-3701-206.....112	131-6593-401.....233	131-8701-261.....125
108-1083-001.....270	131-3303-001.....238	131-3701-211.....112	131-6593-406.....134	131-8701-266.....125
108-1087-001.....270	131-3303-006.....110	131-3701-216.....112	131-6593-406.....233	131-8701-301.....126
108-1702-101.....268	131-3303-006.....238	131-3701-231.....112	131-6701-201.....135	131-8701-306.....126
108-1703-101.....268	131-3303-401.....110	131-3701-236.....112	131-6701-206.....135	131-8701-311.....126
108-1722-101.....269	131-3303-401.....238	131-3701-261.....112	131-6701-211.....135	131-8701-316.....126
108-1723-101.....269	131-3303-406.....110	131-3701-266.....112	131-6701-216.....135	131-8701-501.....126
108-1762-101.....269	131-3303-406.....238	131-3701-271.....112	131-6701-301.....135	131-8701-506.....126
108-1763-101.....269	131-3303-501.....110	131-3701-276.....112	131-6701-401.....136	131-8701-601.....127

While every precaution has been taken to ensure accuracy and completeness herein, Emerson Network Power Connectivity Solutions assumes no responsibility, and disclaims all liability for damages resulting from use of this information or for any errors or omissions. Specifications subject to change without notice.



## Part Number Index

142-0761-871.....	228	142-1701-571.....	73	142-4403-101.....	80
142-0761-881.....	92	142-1701-576.....	73	142-4403-101.....	224
142-0761-881.....	228	142-1701-581.....	73	142-4403-106.....	80
142-0761-891.....	93	142-1701-586.....	73	142-4403-106.....	224
142-0761-891.....	228	142-1701-591.....	73	142-4404-001.....	80
142-0771-821.....	92	142-1701-596.....	73	142-4404-001.....	219
142-0771-821.....	228	142-1701-601.....	70	142-4404-006.....	80
142-0771-831.....	93	142-1701-606.....	72	142-4404-006.....	219
142-0771-831.....	228	142-1701-611.....	72	142-4404-101.....	80
142-0791-801.....	63	142-1701-616.....	72	142-4404-101.....	224
142-0791-801.....	227	142-1701-621.....	72	142-4404-106.....	80
142-0791-801.....	236	142-1701-626.....	72	142-4404-106.....	224
142-0791-811.....	63	142-1701-631.....	72	142-4407-001.....	80
142-0791-811.....	227	142-1701-636.....	72	142-4407-001.....	219
142-0791-811.....	236	142-1701-641.....	72	142-4407-001.....	220
142-0791-821.....	63	142-1701-646.....	72	142-4407-006.....	80
142-0791-821.....	227	142-1701-701.....	69	142-4407-006.....	219
142-0791-821.....	236	142-1701-706.....	69	142-4407-006.....	220
142-0801-201.....	56	142-1701-821.....	63	142-4407-101.....	80
142-0801-206.....	56	142-1701-821.....	227	142-4407-101.....	224
142-0801-301.....	56	142-1701-821.....	236	142-4407-101.....	229
142-0801-306.....	56	142-1701-831.....	63	142-4407-106.....	80
142-0801-421.....	55	142-1701-831.....	227	142-4407-106.....	224
142-0801-421.....	216	142-1701-831.....	236	142-4407-106.....	229
142-0801-801.....	59	142-1711-001.....	69	142-4408-001.....	80
142-0801-806.....	59	142-1711-006.....	69	142-4408-001.....	219
142-0801-811.....	59	142-1711-011.....	70	142-4408-006.....	80
142-0801-816.....	59	142-1711-016.....	70	142-4408-006.....	219
142-0801-821.....	59	142-1711-021.....	70	142-4408-101.....	80
142-0801-826.....	59	142-1711-026.....	70	142-4408-101.....	224
142-0801-831.....	59	142-1711-031.....	70	142-4408-106.....	80
142-0801-836.....	59	142-1711-036.....	70	142-4408-106.....	224
142-0901-401.....	76	142-1711-061.....	70	142-4435-001.....	80
142-0901-406.....	76	142-1711-066.....	70	142-4435-001.....	220
142-0901-801.....	76	142-1711-511.....	74	142-4435-006.....	80
142-0901-806.....	76	142-1711-516.....	74	142-4435-006.....	220
142-0901-811.....	76	142-1711-521.....	74	142-4435-101.....	80
142-0901-816.....	76	142-1711-526.....	74	142-4435-101.....	229
142-0901-821.....	76	142-1721-001.....	65	142-4435-106.....	80
142-0901-826.....	76	142-1721-006.....	65	142-4435-106.....	229
142-0901-861.....	77	142-1721-011.....	65	142-4439-001.....	80
142-0901-866.....	77	142-1721-016.....	65	142-4439-001.....	220
142-0901-921.....	77	142-1721-021.....	66	142-4439-006.....	80
142-0901-931.....	77	142-1721-026.....	66	142-4439-006.....	220
142-0901-941.....	77	142-1721-031.....	66	142-4439-101.....	80
142-1000-001.....	75	142-1721-036.....	66	142-4439-101.....	229
142-1000-002.....	75	142-1721-041.....	66	142-4439-106.....	80
142-1000-003.....	75	142-1721-046.....	66	142-4439-106.....	229
142-1000-004.....	75	142-1721-051.....	66	142-4701-201.....	81
142-1000-033.....	44	142-1721-056.....	66	142-4701-206.....	81
142-1403-001.....	49	142-1731-006.....	64	142-4701-501.....	81
142-1403-001.....	219	142-1731-011.....	64	142-4701-506.....	81
142-1403-006.....	219	142-1731-016.....	64	142-4701-801.....	81
142-1404-001.....	49	142-1731-021.....	64	142-4701-806.....	81
142-1404-001.....	219	142-1731-026.....	64	142-5303-401.....	84
142-1404-006.....	219	142-1731-031.....	64	142-5303-401.....	219
142-1407-001.....	49	142-1731-036.....	64	142-5303-406.....	84
142-1407-001.....	219	142-1801-551.....	74	142-5303-406.....	219
142-1407-006.....	219	142-1801-556.....	74	142-5304-401.....	84
142-1408-001.....	49	142-1801-561.....	74	142-5304-401.....	219
142-1408-001.....	219	142-1801-566.....	74	142-5304-406.....	84
142-1408-006.....	219	142-1801-571.....	74	142-5304-406.....	219
142-1701-011.....	68	142-1801-576.....	74	142-5307-401.....	84
142-1701-016.....	68	142-1801-601.....	74	142-5307-401.....	219
142-1701-031.....	67	142-1801-606.....	74	142-5307-406.....	84
142-1701-036.....	67	142-1801-611.....	74	142-5307-406.....	219
142-1701-041.....	68	142-1801-616.....	74	142-5308-401.....	84
142-1701-046.....	68	142-1801-621.....	74	142-5308-401.....	219
142-1701-121.....	68	142-1801-626.....	74	142-5308-406.....	84
142-1701-126.....	68	142-1901-821.....	49	142-5308-406.....	219
142-1701-131.....	67	142-4303-401.....	80	142-5403-001.....	84
142-1701-136.....	67	142-4303-401.....	219	142-5403-001.....	219
142-1701-191.....	69	142-4303-406.....	80	142-5403-006.....	84
142-1701-196.....	69	142-4304-401.....	80	142-5403-006.....	219
142-1701-201.....	68	142-4304-401.....	219	142-5403-101.....	84
142-1701-206.....	68	142-4307-401.....	80	142-5403-101.....	224
142-1701-501.....	72	142-4307-401.....	219	142-5403-106.....	84
142-1701-506.....	72	142-4307-406.....	80	142-5403-106.....	224
142-1701-511.....	72	142-4307-406.....	219	142-5404-001.....	84
142-1701-516.....	72	142-4308-401.....	80	142-5404-001.....	219
142-1701-536.....	73	142-4308-401.....	219	142-5404-006.....	84
142-1701-541.....	73	142-4308-406.....	80	142-5404-006.....	219
142-1701-546.....	73	142-4403-001.....	80	142-5407-001.....	84
142-1701-551.....	73	142-4403-001.....	219	142-5407-001.....	219
142-1701-556.....	73	142-4403-006.....	80	142-5407-001.....	220
142-1701-566.....	73	142-4403-006.....	219	142-5407-006.....	84

142-5407-006.....	219	251-0111-003.....	273
142-5407-006.....	220	251-0115-002.....	273
142-5407-101.....	84	415-0001-006.....	169
142-5407-101.....	224	415-0001-012.....	169
142-5407-101.....	229	415-0001-018.....	169
142-5407-106.....	84	415-0001-024.....	169
142-5407-106.....	224	415-0001-030.....	169
142-5407-106.....	229	415-0001-036.....	169
142-5408-001.....	84	415-0002-006.....	169
142-5408-001.....	219	415-0002-012.....	169
142-5408-006.....	84	415-0002-018.....	169
142-5408-006.....	219	415-0002-024.....	169
142-5408-101.....	84	415-0002-030.....	169
142-5408-101.....	224	415-0002-036.....	169
142-5408-106.....	84	415-0003-006.....	168
142-5408-106.....	224	415-0003-012.....	168
142-5435-001.....	84	415-0003-018.....	168
142-5435-001.....	220	415-0003-024.....	168
142-5435-006.....	84	415-0003-030.....	168
142-5435-006.....	220	415-0003-036.....	168
142-5435-101.....	84	415-0004-006.....	169
142-5435-101.....	229	415-0004-012.....	169
142-5435-106.....	84	415-0004-018.....	169
142-5435-106.....	229	415-0004-024.....	169
142-5439-001.....	84	415-0004-030.....	169
142-5439-001.....	220	415-0004-036.....	169
142-5439-006.....	84	415-0005-006.....	169
142-5439-006.....	220	415-0005-012.....	169
142-5439-101.....	84	415-0005-018.....	169
142-5439-101.....	229	415-0005-024.....	169
142-5439-106.....	84	415-0005-030.....	169
142-5439-106.....	229	415-0005-036.....	169
142-5701-201.....	85	415-0006-006.....	169
142-5701-201.....	85	415-0006-012.....	169
142-5701-206.....	85	415-0006-018.....	169
142-5701-501.....	85	415-0006-024.....	169
142-5701-506.....	85	415-0006-030.....	169
142-5701-801.....	85	415-0006-036.....	169
142-5701-801.....	85	415-0007-006.....	169
142-5701-811.....	85	415-0007-012.....	169
142-5701-816.....	85	415-0007-018.....	169
142-9303-411.....	219	415-0007-024.....	169
142-9303-411.....	219	415-0007-030.....	169
142-9403-011.....	87	415-0007-036.....	169
142-9403-011.....	219	415-0008-006.....	169
142-9403-101.....	87	415-0008-012.....	169
142-9403-101.....	224	415-0008-018.....	169
142-9404-011.....	87	415-0008-024.....	169
142-9404-101.....	87	415-0008-030.....	169
142-9404-101.....	224	415-0008-036.....	169
142-9407-001.....	87	415-0009-006.....	170
142-9407-001.....	219	415-0009-012.....	170
142-9407-101.....	87	415-0009-018.....	170
142-9407-101.....	224	415-0009-024.....	170
142-9701-201.....	88	415-0009-030.....	170
142-9701-211.....	88	415-0010-006.....	169
142-9701-301.....	88	415-0010-012.....	169
142-9701-801.....	89	415-0010-018.....	169
142-9701-811.....	89	415-0010-024.....	169
142-9801-201.....	88	415-0010-030.....	169
144-0000-910.....	187	415-0010-036.....	169
144-0000-910.....	273	415-0011-006.....	170
145-0693-001.....	43	415-0011-012.....	170
145-0693-001.....	212	415-0011-018.....	170
145-0693-002.....	43	415-0011-024.....	170
145-0693-002.....	212	415-0011-030.....	170
145-0694-001.....	43	415-0011-036.....	170
145-0694-001.....	212	415-0013-006.....	170
145-0694-002.....	43	415-0013-012.....	170
145-0694-002.....	212	415-0013-018.....	170
145-0701-001.....	43	415-0013-024.....	170
145-0701-002.....	43	415-0013-030.....	170
145-0701-601.....	43	415-0013-036.....	170
145-0701-602.....	43	415-0014-006.....	164
145-0701-611.....	43	415-0014-012.....	164
145-0701-612.....	43	415-0014-018.....	164
145-0901-801.....	44	415-0014-024.....	164
145-0901-811.....	44	415-0014-030.....	164
145-0901-821.....	44	415-0014-036.....	164
146-0403-007.....	184	415-0015-006.....	164
146-0403-007.....	256	415-0015-012.....	164
146-0403-107.....	184	415-0015-018.....	164
146-0403-107.....	255	415-0015-024.....	164
146-0404-007.....	184	415-0015-030.....	164
146-0404-007.....	256	415-0015-036.....	164
146-0404-107.....	184	415-0016-006.....	164
146-0404-107.....	255	415-0016-012.....	164
146-0701-201.....	184	415-0016-018.....	164
146-0701-301.....	184	415-0016-024.....	164
1-8-0313-001.....	268		

415-0016-030.....	164	415-0032-012.....	167
415-0016-036.....	164	415-0032-018.....	167
415-0017-006.....	164	415-0032-024.....	167
415-0017-012.....			



# Competitor Cross Reference

# Competitor Cross Reference

BNC-PS3C-174.....CPM-88-19	H-6932-000-000.....131-3701-411	700053.....131-6701-201	5604-5CC.....142-1701-511	5941-2CC-SF.....142-1701-586	3131-18-1.....142-1701-521	01-2255-3.....108-0754-001	9852-0081-6220.....142-1801-626	1464-105.....111-0110-001	325-102.....105-2202-105
BNC-PS3C-P5962.....CPMC-88-10	H-6937-000-000.....131-3701-401	700056.....131-6701-301	5604-5CC-SF.....142-1701-516	5941-4CC.....142-1701-551	3131-18-9.....142-1701-526	01-2310-1.....108-0750-001	9852-0081-6220.....142-1801-636	1464-107.....111-0107-001	325-103.....105-2203-105
BNC-PS3C-PL58.....CPMC-88-11	H-6957-000-000.....131-3901-401	700166.....131-3701-411	5604-6CC.....142-1701-521	5941-4CC-SF.....142-1701-556	3131-20-1.....142-1701-531	01-2312-1.....108-0750-002	9852-0781-6215.....142-1801-606	1483-102.....111-0702-001	325-104.....105-2204-105
BNC-T-JPJ.....CP-AD505	H-6991-000-000.....131-3801-201	700169.....131-3701-401	5604-6CC-SF.....142-1701-526	5941-5CC.....142-1701-561	3131-20-9.....142-1701-536	01-2341-1-02.....108-0753-102	9852-0781-6215.....142-1801-616	1483-103.....111-0703-001	325-107.....105-2207-105
TNC-A5-JJ.....CP-AD355	H-6993-000-000.....131-1801-371	700178.....131-3593-401	5606-2CC.....142-1801-631	5941-5CC-SF.....142-1701-566	3131-36-1.....142-1701-541	01-2520-2.....108-2300-501	9852-0781-6220.....142-1801-626	1498-102.....108-2302-621	3502-101.....105-0251-001
TNC-PS3C-58.....CPMC-TNC-1	H-6995-000-000.....131-1701-201	700188.....131-3901-401	5606-2CC-SF.....142-1801-636	5941-6CC.....142-1701-571	3131-36-9.....142-1701-546	01-2540-1-02.....108-0740-102	9852-0781-6220.....142-1801-636	1498-103.....108-2303-621	3502-102.....105-0252-001
TNC-PS3C-5962.....CPMC-TNC-2	H-6995-000-000.....131-3701-201	700209.....131-1701-201	5606-4CC.....142-1801-601	5941-6CC-SF.....142-1701-576	3131K-12-1.....142-1701-551	01-2552-1-0210.....108-0253-001	9854-0081-6217.....142-1801-556	1499-102.....108-2302-621	3502-103.....105-0253-001
	H-6997-000-000.....131-1701-371	700209.....131-3701-201	5606-4CC-SF.....142-1801-606	5942-4CC.....142-1801-551	3131K-12-9.....142-1701-556	01-2552-1-0212.....108-0252-001	9854-0081-6217.....142-1801-566	1499-103.....108-2303-621	359-101.....105-2201-101
<b>ANRITSU.....EMERSON</b>	H-6997-000-000.....131-3701-301	700213.....131-3801-201	5606-5CC.....142-1801-611	5942-4CC-SF.....142-1801-556	3131K-15-1.....142-1701-561	09-9074-1-0310.....105-0203-200	9854-0081-6220.....142-1801-536	1501-101.....105-0201-200	359-102.....105-2202-101
K100B.....142-1000-033	S1333-2704-308.....142-0701-411	700213.....131-3801-201	5606-5CC-SF.....142-1801-616	5942-5CC.....142-1801-561	3131K-15-9.....142-1701-566	09-9074-1-0312.....105-0202-200	9854-0081-6227.....142-1801-576	1501-102.....105-0202-200	359-103.....105-2203-101
K101M-85.....145-0693-002		700214.....131-1701-371	5606-6CC.....142-1801-621	5942-5CC-SF.....142-1801-561	3131K-18-1.....142-1701-571	09-9074-1-0315.....105-0204-200	9854-0781-6217.....142-1801-556	1501-102.....105-0202-200	359-103.....105-2203-101
K102F.....145-0701-002	<b>BERG.....EMERSON</b>	700214.....131-3701-301	5606-6CC-SF.....142-1801-626	5942-6CC.....142-1801-571	3131K-18-9.....142-1701-576	09-9074-1-0316.....105-0210-200	9854-0781-6217.....142-1801-566	1501-103.....105-0203-200	359-104.....105-2204-101
K103F.....145-0701-602	32AS100-1.....131-3901-401	700218.....131-1801-371	5607-4CC.....142-1801-551	5942-6CC-SF.....142-1801-576	3131K-20-1.....142-1701-581	09-9074-1-0319.....105-0210-200	9854-0781-6217.....142-1801-566	1501-104.....105-0204-200	359-107.....105-2207-101
K104F.....145-0701-612	32J102-1.....131-3303-001	700218.....131-1801-371	5607-4CC-SF.....142-1801-556	5942-6CC-SF.....142-1801-576	3131K-20-9.....142-1701-586	09-9074-1-0319.....105-0201-200	9854-0781-6227.....142-1801-536	1501-105.....105-0210-200	398-101.....108-2301-801
	32JR104-1.....131-3701-401	700306.....131-6403-001	5607-5CC.....142-1801-561	5980-1CC.....142-1701-541	3131K-20-9.....142-1701-586	09-9126-1-04410.....108-0903-001	9854-0781-6227.....142-1801-576	1502-10X.....105-025X-001	398-102.....108-2302-801
<b>AUTOMATIC.....EMERSON</b>	32JR107-1.....131-3701-201	700311.....131-6303-401	5607-5CC-SF.....142-1801-566	5980-1CC-SF.....142-1701-546	3310-20-9.....142-1801-536	09-9126-1-04411.....108-0908-001	9952-0081-6215.....142-1701-606	1508-101.....108-0901-001	398-103.....108-2303-801
3301-640-919.....142-0403-001	32JR110-1.....131-3701-411	700326.....131-6403-101	5607-6CC.....142-1801-571	5980-2CC.....142-1701-531	3310-20-9.....142-1801-536	09-9126-1-04412.....108-0902-001	9952-0081-6215.....142-1701-616	1508-102.....108-0902-001	398-104.....108-2304-801
3301-940-801.....142-0202-011	32JR111-1.....131-3701-301	700400.....131-3303-001	5607-6CC-SF.....142-1801-576	5980-2CC-SF.....142-1701-536	3310-36-1.....142-1801-541	09-9126-1-04413.....108-0906-001	9952-0081-6220.....142-1701-626	1508-103.....108-0903-001	398-105.....108-2310-801
3301-940-819.....142-0203-011	32JR112-1.....131-3701-341	700401.....131-3302-001	5608-2CC.....142-1801-531	5980-4CC.....142-1701-501	3310K-12-1.....142-1801-551	09-9126-1-04414.....108-0907-001	9952-0081-6220.....142-1701-636	1508-104.....108-0904-001	398-107.....108-2307-801
3301-940-888.....142-0207-011	32JR189-1.....131-3711-201	700405.....131-1403-001	5608-2CC-SF.....142-1801-536	5980-4CC-SF.....142-1701-506	3310K-12-9.....142-1801-556	09-9126-1-04415.....108-0904-001	9952-0081-6236.....142-1701-646	1508-105.....108-0910-001	455-101.....108-0301-001
3302-640-901.....142-0402-101	32P100-1.....131-1403-001	700406.....131-3402-001	5663-2CC.....142-1701-631	5980-5CC.....142-1701-511	3310K-12-9.....142-1801-556	09-9126-1-04416.....108-0910-001	9952-0781-6215.....142-1701-606	1508-106.....108-0906-001	455-102.....108-0302-001
3302-640-980.....142-0407-101	32P100-6.....131-3402-001	700425.....131-1403-101	5663-2CC-SF.....142-1701-636	5980-6CC.....142-1701-521	3310K-15-1.....142-1801-561	09-9126-1-04417.....108-0912-001	9952-0781-6215.....142-1701-616	1508-107.....108-0907-001	455-103.....108-0303-001
3302-940-801.....142-0202-101	32P111-1.....131-1403-101	700425.....131-1403-101	5663-4CC.....142-1701-601	5980-6CC-SF.....142-1701-526	3310K-15-9.....142-1801-566	09-9126-1-04418.....108-0913-001	9952-0781-6220.....142-1701-626	1508-108.....108-0908-001	455-104.....108-0304-001
3302-940-819.....142-0203-101	32P111-13.....131-1402-101	700426.....131-1402-101	5663-4CC-SF.....142-1701-606	5981-1CC.....142-1701-641	3310K-18-1.....142-1801-571	09-9126-1-04419.....108-0901-001	9952-0781-6220.....142-1701-636	1508-112.....108-0912-001	455-105.....108-0310-001
3302-940-888.....142-0207-101	32PR103-1.....131-3801-201	700426.....131-1402-101	5663-5CC.....142-1701-611	5981-1CC-SF.....142-1701-646	3310K-18-9.....142-1801-576	09-9201-1-0310.....105-2203-105	9954-0081-6215.....142-1701-506	1508-113.....108-0913-001	455-106.....108-0306-001
3307-640-901.....142-0302-401	32PR104-1.....131-3801-301	700466.....131-3693-001	5663-5CC-SF.....142-1701-616	5981-2CC.....142-1701-631	12/1/11.....142-1801-601	09-9201-1-0312.....105-2202-105	9954-0081-6215.....142-1701-516	1509-101.....108-0901-001	455-107.....108-0307-001
3307-640-919.....142-0303-401	37JR101-1.....131-6701-411	700473.....131-1693-101	5663-6CC.....142-1701-621	5981-2CC-SF.....142-1701-636	12/9/11.....142-1801-606	09-9201-1-0314.....105-2207-105	9954-0081-6217.....142-1701-556	1509-102.....108-0902-001	455-108.....108-0308-001
3307-940-801.....142-0102-401	37JR104-2.....131-6701-201	700473.....131-1693-101	5663-6CC-SF.....142-1701-626	5981-4CC.....142-1701-601	3311-15-1.....142-1801-611	09-9201-1-0315.....105-2204-105	9954-0081-6217.....142-1701-566	1509-103.....108-0903-001	455-112.....108-0312-001
3307-940-819.....142-0103-401	37JR108-1.....131-6701-401		5664-2CC.....142-1801-631	5981-4CC-SF.....142-1701-606	3311-15-9.....142-1801-616	09-9201-1-0319.....105-2201-105	9954-0081-6220.....142-1701-526	1509-104.....108-0904-001	455-113.....108-0313-001
E-3301-042-104.....142-0694-001	37JR110-1.....131-6701-301	<b>CDI/TENSOLITE.....EMERSON</b>	5664-2CC-SF.....142-1801-636	5981-5CC.....142-1701-611	3311-18-1.....142-1801-621	09-9221-1-0110.....105-0853-001	9954-0081-6220.....142-1701-536	1509-105.....108-0910-001	456-101.....108-0301-001
E-3301-044-104.....142-0694-031	37JS102-1.....131-6303-401	201-1CC.....145-0694-001	5664-4CC.....142-1801-601	5981-5CC-SF.....142-1701-616	3311-18-9.....142-1801-626	09-9221-1-0111.....105-0858-001	9954-0081-6227.....142-1701-576	1509-106.....108-0906-001	456-102.....108-0302-001
E-3301-044-124.....142-0693-001	37P104-1.....131-6403-101	201-1CCSF.....145-0694-002	5664-4CC-SF.....142-1801-606	5981-6CC.....142-1701-621	3311-20-1.....142-1801-631	09-9221-1-0112.....105-0852-001	9954-0081-6236.....142-1701-546	1509-107.....108-0907-001	456-103.....108-0303-001
E-3302-045-919.....142-0403-101	37P106-1.....131-6403-001	201-2CC.....145-0693-001	5664-5CC.....142-1801-611	5981-6CC-SF.....142-1701-626	3311-20-9.....142-1801-636	09-9221-1-0113.....105-0856-001	9954-0781-6215.....142-1701-506	1509-108.....108-0908-001	456-104.....108-0304-001
E-3306-942-104.....142-0594-001	37T100-1.....142-0003-301	201-2CCSF.....145-0693-002	5664-5CC-SF.....142-1801-616	5982-1CC.....142-1801-541	3311-36-1.....142-1801-641	09-9221-1-0114.....105-0857-001	9954-0781-6215.....142-1701-506	1509-112.....108-0912-001	456-105.....108-0310-001
E-3306-942-124.....142-0593-001	39JR128-5.....142-0701-301	204CC.....145-0701-001	5664-6CC.....142-1801-621	5982-1CC-SF.....142-1801-546	3311-36-9.....142-1801-646	09-9221-1-0115.....105-0854-001	9954-0781-6215.....142-1701-516	1509-113.....108-0913-001	456-106.....108-0306-001
E-3307-962-104.....142-0594-401	39JR1359-1.....142-0701-201	223CC.....145-0901-811	5664-6CC-SF.....142-1801-626	5982-2CC.....142-1801-531		09-9221-1-0116.....105-0860-001	9954-0781-6217.....142-1701-556	1513-102.....105-0702-001	456-107.....108-0307-001
E-3307-962-124.....142-0593-401	39JR1363-1.....142-0701-876	224CC.....145-0901-801	5665-2CC.....142-1701-531	5982-2CC-SF.....142-1801-536		09-9221-1-0119.....105-0851-001	9954-0781-6220.....142-1701-526	1513-103.....105-0703-001	456-108.....108-0308-001
E-3337-945-000.....142-0701-401	39JR1364-1.....142-0701-506	225CC.....145-0901-821	5665-2CC-SF.....142-1701-536	5983-1CC.....142-1801-641		21-9205-1-0110.....105-0753-001	9954-0781-6220.....142-1701-536	1598-10X.....105-104X-001	456-112.....108-0312-001
E-3341-000-000.....142-0701-631	39JR1364-2.....142-0701-501	230CC.....145-0701-611	5665-4CC.....142-1701-501	5983-1CC-SF.....142-1801-646		21-9205-1-0111.....105-0758-001	9954-0781-6220.....142-1701-536	1675-10X.....108-025X-001	456-113.....108-0313-001
E-3341-960-100.....142-0701-621	69JR100-2.....135-3701-201	230CCSF.....145-0701-612	5665-4CC-SF.....142-1701-506	5983-2CC.....142-1801-631		21-9205-1-0112.....105-0752-001	9954-0781-6227.....142-1701-576	1677-102.....108-0252-001	457-10X.....108-030X-001
E-3352-960-000.....142-0901-811	69JR101-2.....135-3701-301	231CC.....145-0701-601	5665-5CC.....142-1701-511	5983-2CC-SF.....142-1801-636		21-9205-1-0113.....105-0756-001	9954-0781-6227.....142-1701-576	1677-103.....108-0253-001	458-10X.....108-030X-001
E-3353-000-000.....142-0901-821	69JR103-2.....135-3711-801	231CCSF.....145-0701-602	5665-5CC-SF.....142-1701-516	5983-2CC-SF.....142-1801-636		21-9205-1-0114.....105-0757-001	9954-0781-6215.....142-1701-516	204-102.....108-1702-101	476-10X.....108-030X-001
E-3356-000-000.....142-0901-801	69P101-2.....135-3801-201	240CCSF.....145-0701-002	5665-6CC.....142-1701-521	5983-4CC.....142-1801-601		21-9205-1-0115.....105-0754-001	9954-0781-6215.....142-1701-516	204-103.....108-1703-101	477-10X.....108-030X-001
E-3357-040-									







# Competitor Cross Reference

## Ultra Miniature Connectors UMC to U.FL Cross Reference

Emerson	Hirose
128-0711-201	U.FL-R-SMT(10)
415-0084-050	U.FL-2LP(V)-04N1-A-50
415-0084-100	U.FL-2LP(V)-04N1-A-100
415-0084-150	U.FL-2LP(V)-04N1-A-150
415-0084-200	U.FL-2LP(V)-04N1-A-200
415-0084-250	U.FL-2LP(V)-04N1-A-250
415-0084-300	U.FL-2LP(V)-04N1-A-300
415-0084-500	U.FL-2LP(V)-04N1-A-500
415-0085-050	U.FL-2LP-04N2-A-50
415-0085-100	U.FL-2LP-04N2-A-100
415-0085-150	U.FL-2LP-04N2-A-150
415-0085-200	U.FL-2LP-04N2-A-200
415-0085-250	U.FL-2LP-04N2-A-250
415-0085-300	U.FL-2LP-04N2-A-300
415-0085-300	U.FL-2LP-04N2-A-500
415-0086-050	U.FL-2LP-068N2-A-50
415-0086-100	U.FL-2LP-068N2-A-100
415-0086-150	U.FL-2LP-068N2-A-150
415-0086-200	U.FL-2LP-068N2-A-200
415-0086-250	U.FL-2LP-068N2-A-250
415-0086-300	U.FL-2LP-068N2-A-300
415-0086-500	U.FL-2LP-068N2-A-500
415-0087-050	U.FL-2LP-066J2-A-50

Emerson	Hirose
415-0087-100	U.FL-2LP-066J2-A-100
415-0087-150	U.FL-2LP-066J2-A-150
415-0087-200	U.FL-2LP-066J2-A-200
415-0087-250	U.FL-2LP-066J2-A-250
415-0087-300	U.FL-2LP-066J2-A-300
415-0087-500	U.FL-2LP-066J2-A-500
415-0088-050	U.FL-2LP-088K2T-A-50
415-0088-100	U.FL-2LP-088K2T-A-100
415-0088-150	U.FL-2LP-088K2T-A-150
415-0088-200	U.FL-2LP-088K2T-A-200
415-0088-250	U.FL-2LP-088K2T-A-250
415-0088-300	U.FL-2LP-088K2T-A-300
415-0088-500	U.FL-2LP-088K2T-A-500
415-0104-150	U.FL-LP(V)-04N1-A-150
415-0104-250	U.FL-LP(V)-04N1-A-250
415-0105-150	U.FL-LP-04N2-A-150
415-0105-250	U.FL-LP-04N2-A-250
415-0106-150	U.FL-LP-068N2-A-150
415-0106-250	U.FL-LP-068N2-A-250
415-0107-150	U.FL-LP-066J2-A-150
415-0107-250	U.FL-LP-066J2-A-250
415-0108-150	U.FL-LP-088K2T-A-150
415-0108-250	U.FL-LP-088K2T-A-25

# Competitor Cross Reference

## UMC Compatibility Table Emerson vs. HIROSE

UMC Family	Mated Height (mm)	AWG (O.D. mm)	Emerson		HIROSE	
			Plating (Contact/Ground)	Part No.	Plating (Contact/Ground)	Part No.
UMC Receptacle	2.5	N/A	Gold	128-0711-201	Gold/Silver	U.FL-R-SMT (10)
UMC MP Plug	2.5	30 (1.37)	Gold	415-0088-xxx	Gold/Silver	U.FL-LP-088
UMC MP Plug	2.5	32 (1.32)	Gold	415-0087-xxx	Gold/Silver	U.FL-LP-066
		32 (1.13)	Gold	415-0086-xxx	Gold/Silver	U.FL-LP-066
		36 (0.81)	Gold	415-0085-xxx	Gold/Silver	U.FL-LP-040
UMC LP Plug	2.0	36 (0.81)	Gold	415-0084-xxx	Gold/Silver	U.FL-LP(V)-040
UMC ULP Plug	1.55	N/A	Gold	415-0109-xxx	Gold/Silver	CL-331-0482-6-10

## Non-Magnetic RF Competitor Cross Reference

Emerson Part No.	Competitor Part No.	Competitor
135-9403-001	908-NM41300	Amphenol
135-9402-001	908-NM41200	Amphenol
135-9403-101	908-NM43300	Amphenol
135-9402-111	908-NM43200	Amphenol
135-9701-201	908-NM22106	Amphenol
135-9701-301	908-NM24100	Amphenol
133-9403-001	919-NM101P-51S	Amphenol
133-9403-101	919-NM104P-51A	Amphenol
133-9402-101	919-NM109J-51P	Amphenol
133-9701-201	919-NM109J-51P	Amphenol
131-9403-021	903NM285P-51S	Amphenol
131-9403-101	903-NM289P-51A	Amphenol
131-9701-201	903-NM415J-51P	Amphenol
135-9402-111	R110 170 117	Radiall
135-9701-201	R110 426 097	Radiall
142-9407-001	R125 075 097	Radiall
142-9403-101	R125 172 167	Radiall
142-9701-201	R125 426 067	Radiall
131-9403-021	R114 082 097	Radiall
131-9403-101	R114 186 097	Radiall

Type N Competitor Cross Reference

Emerson	Radiall	M/A-Com	Amphenol	Tyco/Amp	Telegartner	Rosenberger	Huber-Suhner
138-4303-407	R161311300	3004-7388-10	82-6156			53K507-802N3	
138-4304-407	R161311300					53K507-803N3	
138-4307-407	R161329000	3004-7341-10	82-5378	1-225667-2	J01021A0147	53K507-106N3	24N-50-3-11C
138-4308-407	R161329200	3004-7341-10	82-5373	225363-2	J01021A0148	53K507-108N3	24N-50-3-12C
138-4316-407	R161331000	N15H61H001X99	82-346-RFX	225094-2	J01021A0060	53K501-115N3	24N-50-7-14C
138-4318-407	R161331200	N15H61H004X99		225667-1	J01021A0092	53K501-117N3	24N-50-7-15C
138-4349-407	R161331060		82-6143-1000				
138-4403-007	R161072000	3031-7338-10			J01020A0103	53S107-802N3	
138-4403-107	R161181000		82-6048-1000		J01020A0040		
138-4404-007	R161072000				J01020A0104	53S107-803N3	
138-4404-107	R161181300				J01020A0039		
138-4407-007	R161082000	3031-7358-10	82-5375	1-225661-2	J01010A0108	53S107-106N3	11N-50-3-28C
138-4407-107	R161182000			1-225669-2	J01020A0035	53S205-315N3	16N-50-3-26C
138-4408-007	R161083000	3031-7341-10	82-5370	225699-1	J01020A0113	53S107-108N3	11N-50-3-29C
138-4408-107	R161183000		82-4442	225365-2	J01020A0036	53S205-317N3	16N-50-3-27C
138-4416-007	R161075000	N15A61H001X99	82-340	225661-2	J01020A0107	53S101-115N3	11N-50-7-43C
138-4416-107	R161184000	N15B61H001X99	82-336	225669-2	J01020A0046		16N-50-7-30C
138-4418-007	R161088000	N15A61H004X99	82-332	225661-1	J01020A0110	53S101-115N3	11N-50-7-44C
138-4418-107	R161186000	N15B61H004X99	82-4440-1001	225669-1	J01020A0045		16N-50-7-31C
138-4449-007	R161075060		82-340-1052		J01020A0127	53S101-1N9N3	
138-4593-401	R161335200	3004-7985-00	82-6093-RFX	228658-2	J01021H0087	52K504-271N3	24N-50-2-14
138-4594-401	R161336000	3004-7941-00	82-6097-RFX	228658-1	J01021A0151	53K504-272N3	24N-50-3-14
138-4596-401	R161337200		82-6162		J01021A0109	53K504-273N3	24N-50-5-39C
138-4693-001	R161050300	3001-7985-00		1057094-1			11N-50-2-14
138-4693-011	R161050300	3001-7985-00					11N-50-2-14
138-4694-001	R161051000	3001-7941-00	82-5955-RFX	1057088-1	J01020A0109	53S101-272B1	11N-50-3-13
138-4694-011	R161051000	3001-7941-00	82-5955-RFX		J01020A0109	53S101-272B1	11N-50-3-13
138-4696-001	R161054000		82-6124		J01020A0112	53S101-273B1	11N-50-5-39C
138-4696-011	R161054000		82-6124		J01020A0112	53S101-273B1	11N-50-5-39C
138-4701-407	R161586137	N15M35999X99			J01021A1084	53K505-200N3	
138-4701-607	R161404000	3052-0000-10	82-97	1-1337418-0	J01021A1082	53K401-200N3	23N-50-0-23
138-4901-407	R161730000	N15R07999X99	82-66		J01024A1088	53K501-K00N3	34N-50-0-51
138-4901-807	R161705000	3680-0000-02	82-101	227945-2	J01024A1092	53K101-K00N3	31N-50-0-51
138-4901-817	R161703000	3681-0000-02	82-100	1058661-1	J01024A1094	53K101-S00N3	32N-50-0-51

SMA Stainless Steel Competitor Cross Reference

Emerson	Huber-Suhner	Amp/Tyco	Radiall	Amphenol	AEP
141-0403-012	11SMA-50-2-55C	225532-4	R125072001	901-9511-3SFC	9101-9573-03
141-0404-012	11SMA-50-2-56C		R125072081	901-9511-12SFC	9101-9573-19
141-0407-012	11SMA-50-3-55C	225532-1	R125075001	901-9511-2SF	9101-9573-06
141-0408-012	11SMA-50-3-56C	225532-3	R125076001	901-9511-1SF	9101-9573-01
141-0403-102	16SMA-50-2-55C	225609-4	R125172001	901-9531-3SF	9043-9523-03
141-0404-102	16SMA-50-2-56C		R125174011	901-9531-12SF	9043-9523-19
141-0407-102	16SMA-50-3-55C	225609-1	R125175001	901-9531-2SF	9043-9523-06
141-0408-102	16SMA-50-3-56C	225609-3	R125176001	901-9531-1	9043-9523-01
141-0693-002	11SMA-50-2-65		R125052002	901-9201-2A	9401-1083-010
141-0694-002	11SMA-50-3-65				9401-1083-109
141-0694-012	11SMA-50-3-64		R125054002	901-9201-1A	9301-1063-009
141-0693-062	11SMA-50-2-65		R125052002	901-9723	9401-1583-010
141-0694-062	11SMA-50-3-65		R125057002	901-9808	9401-1583-109
141-0303-412		225608-4	R125312121	901-9610-3SF	9130-9573-03
141-0304-412		1-225608-1	R125313121	901-9610-12SF	9130-9573-19
141-0307-412			R125314121	901-9610-2SF	9130-9573-06
141-0308-412		225608-3	R125315121	901-9610-1SF	9130-9573-01
141-0593-001			R125222000	901-9202-2A	9402-1533-010
141-0594-001			R125225000	901-9202-1A	9402-1583-009
141-0593-401	24SMA-50-2-41		R125326000		9453-1083-010
141-0594-401	24SMA-50-3-41		R125325000		9453-1083-009
141-0593-421	24SMA-50-2-41		R125326000		9453-1583-010
141-0594-421	24SMA-50-3-41		R125325000		9453-1083-009
141-0701-201	82SMA-50-0-1	221789-1	R125426000	901-144	9650-1113-000
141-0701-301	85SMA-50-0-1	221790-1	R125680000	901-143	9647-1513-000
141-0701-402	22SMA-50-0-54	228496-1	R125553001	901-9211-SF	9412-9113-000
141-0701-602	23SMA-50-0-61	221641-1	R125454001		9408-9113-000
141-0701-612	23SMA-50-0-51	221640-1	R125403001	901-9215-SF	9404-9113-000
141-0701-622	23SMA-50-0-63		R125464274	901-9000-CCSF	9008-9113-000
141-0701-602	23SMA-50-0-53		R125415275	901-9204-CCSF	9004-9113-0001

**Emerson Network Power Connectivity Solutions, Inc.,  
including its subsidiaries Stratos International, Inc., Trompeter Electronics, Inc., and Semflex, Inc.**

**TERMS AND CONDITIONS OF SALE**

Emerson Network Power Connectivity Solutions, Inc. is herein referred to as the “Seller” and the customer or person or entity purchasing goods (“Goods”) from Seller is referred to as the “Buyer.” These Terms and Conditions, any price list or schedule, quotation, acknowledgment or invoice from Seller relevant to the sale of the Goods and all documents incorporated by specific reference herein or therein, constitute the complete and exclusive statement of the terms of the agreement governing the sale of Goods by Seller to Buyer. Buyer’s acceptance of the Goods will manifest Buyer’s assent to these Terms and Conditions. Seller reserves the right in its sole discretion to refuse orders.

**1. PRICES:** Unless otherwise specified in writing by Seller, the price quoted or specified by Seller for the Goods shall remain in effect for thirty (30) days after the date of Seller’s quotation or acknowledgment of Buyer’s order for the Goods, whichever occurs first, provided an unconditional authorization from Buyer for the shipment of the Goods is received and accepted by Seller within such time period. If such authorization is not received by Seller within such thirty (30) day period, Seller shall have the right to change the price for the Goods to Seller’s price for the Goods at the time of shipment. All prices are exclusive of taxes, transportation and insurance, which are to be borne by Buyer.

**2. TAXES:** Any current or future tax or governmental charge (or increase in same) affecting Seller’s costs of production, sale, or delivery or shipment, or which Seller is otherwise required to pay or collect in connection with the sale, purchase, delivery, storage, processing, use or consumption of Goods, shall be for Buyer’s account and shall be added to the price.

**3. TERMS OF PAYMENT:** Unless otherwise specified by Seller, terms are net thirty (30) days from date of Seller’s invoice in U.S. currency. Seller shall have the right, among other remedies, either to terminate this agreement or to suspend further performance under this and/or other agreements with Buyer in the event Buyer fails to make any payment when due, which other agreements Buyer and Seller hereby amend accordingly. Buyer shall be liable for all expenses, including attorneys’ fees, relating to the collection of past due amounts. If any payment owed to Seller is not paid when due, it shall bear interest, at a rate to be determined by Seller, which shall not exceed the maximum rate permitted by law, from the date on which it is due until it is paid. Should Buyer’s financial responsibility become unsatisfactory to Seller, cash payments or security satisfactory to Seller may be required by Seller for future deliveries and for the Goods theretofore delivered. If such cash payment or security is not provided, in addition to Seller’s other rights and remedies, Seller may discontinue deliveries.

**4. SHIPMENT AND DELIVERY:** While Seller will use all reasonable commercial efforts to maintain the delivery date(s) acknowledged or quoted by Seller, all shipping dates are approximate and not guaranteed. Seller reserves the right to make partial shipments. Seller, at its option, shall not be bound to tender delivery of any Goods for which Buyer has not provided shipping instructions and other required information. If the shipment of the Goods is postponed or delayed by Buyer for any reason, Buyer agrees to reimburse Seller for any and all storage costs and other additional expenses resulting therefrom. Risk of loss and legal title to the Goods shall transfer to Buyer for sales in which the end destination of the Goods is outside of the United States immediately after the Goods have passed beyond the territorial limits of the United States. For all other shipments, risk of loss for damage and responsibility shall pass from Seller to Buyer upon delivery to and receipt by carrier at Seller’s shipping point. All shipments are F.O.B. Seller’s shipping point. Any claims for shortages or damages suffered in transit are the responsibility of Buyer and shall be submitted by Buyer directly to the carrier.

Shortages or damages must be identified and signed for at the time of delivery. Buyer shall inspect Goods delivered to it by Seller immediately upon receipt, and, any course of dealing to the contrary notwithstanding, failure of Buyer to give Seller notice of any claim within 30 days after receipt of such Goods shall be an unqualified acceptance of such Goods.

**5. LIMITED WARRANTY:** Subject to the limitations of Section 6, Seller warrants that the Goods manufactured by Seller will be free from defects in material and workmanship under normal use and regular service and maintenance for a period of one year from the date of shipment of the Goods by Seller, unless otherwise specified by Seller in writing. **THIS IS THE SOLE AND EXCLUSIVE WARRANTY GIVEN BY SELLER WITH RESPECT TO THE GOODS AND IS IN LIEU OF AND EXCLUDE ALL OTHER WARRANTIES, EXPRESS OR IMPLIED, ARISING BY OPERATION OF LAW OR OTHERWISE, INCLUDING WITHOUT LIMITATION, MER-**

**CHANTABILITY AND FITNESS FOR A PARTICULAR PURPOSE WHETHER OR NOT THE PURPOSE OR USE HAS BEEN DISCLOSED TO SELLER IN SPECIFICATIONS, DRAWINGS OR OTHERWISE, AND WHETHER OR NOT SELLER’S PRODUCTS ARE SPECIFICALLY DESIGNED AND/OR MANUFACTURED BY SELLER FOR BUYER’S USE OR PURPOSE.**

This warranty does not extend to any losses or damages due to misuse, accident, abuse, neglect, normal wear and tear, negligence (other than Seller’s), unauthorized modification or alteration, use beyond rated capacity, unsuitable power sources or environmental conditions, improper installation, repair, handling, maintenance or application or any other cause not the fault of Seller. To the extent that Buyer or its agents has supplied specifications, information, representation of operating conditions or other data to Seller in the selection or design of the Goods and the preparation of Seller’s quotation, and in the event that actual operating conditions or other conditions differ from those represented by Buyer, any warranties or other provisions contained herein which are affected by such conditions shall be null and void.

If within thirty (30) days after Buyer’s discovery of any warranty defects within the warranty period, Buyer notifies Seller thereof in writing, Seller shall, at its option and as Buyer’s exclusive remedy, repair, correct or replace F.O.B. point of manufacture, or refund the purchase price for, that portion of the Goods found by Seller to be defective. Failure by Buyer to give such written notice within the applicable time period shall be deemed an absolute and unconditional waiver of Buyer’s claim for such defects. All costs of dismantling, reinstallation and freight and the time and expense of Seller’s personnel and representatives for site travel and diagnosis under this warranty shall be borne by Buyer unless accepted in writing by Seller. Goods repaired or replaced during the warranty period shall be covered by the foregoing warranty for the remainder of the original warranty period or ninety (90) days from the date of shipment, whichever is longer.

Buyer assumes all other responsibility for any loss, damage, or injury to persons or property arising out of, connected with, or resulting from the use of Goods, either alone or in combination with other products/components.

Section 5 applies to any entity or person who may buy, acquire or use the Goods, including any entity or person who obtains the Goods from Buyer, and shall be bound by the limitations therein, including Section 6. Buyer agrees to provide such subsequent transferee conspicuous, written notice of the provisions of Sections 5 and 6.

**6. LIMITATION OF REMEDY AND LIABILITY: THE SOLE AND EXCLUSIVE REMEDY FOR BREACH OF ANY WARRANTY HEREUNDER OTHER THAN THE WARRANTY PROVIDED UNDER SECTION 7 SHALL BE LIMITED TO REPAIR, CORRECTION OR REPLACEMENT, OR REFUND OF THE PURCHASE PRICE UNDER SECTION 5.**

**SELLER SHALL NOT BE LIABLE FOR DAMAGES CAUSED BY DELAY IN PERFORMANCE AND THE REMEDIES SET FORTH IN THIS AGREEMENT ARE EXCLUSIVE. IN NO EVENT, REGARDLESS OF THE FORM OF THE CLAIM OR CAUSE OF ACTION (WHETHER BASED IN CONTRACT, INFRINGEMENT, NEGLIGENCE, STRICT LIABILITY, OTHER TORT OR OTHERWISE), SHALL SELLER’S LIABILITY TO BUYER AND/OR ITS CUSTOMERS EXCEED THE PRICE PAID BY BUYER FOR THE SPECIFIC GOODS PROVIDED BY SELLER GIVING RISE TO THE CLAIM OR CAUSE OF ACTION. BUYER AGREES THAT IN NO EVENT SHALL SELLER’S LIABILITY TO BUYER AND/OR ITS CUSTOMERS EXTEND TO INCLUDE INCIDENTAL, CONSEQUENTIAL OR PUNITIVE DAMAGES.** The term “consequential damages” shall include, but not be limited to, loss of anticipated profits, business interruption, loss of use, revenue, reputation and data, costs incurred, including without limitation, for capital, fuel, power and loss or damage to property or equipment.

Buyer expressly acknowledges and agrees that Seller has set its prices and entered into this agreement in reliance upon the limitations of liability and other terms and conditions specified herein, which allocates the risk between Seller and Buyer and form a basis of this bargain between the parties.

It is expressly understood that any technical advice furnished by Seller with respect to the use of the Goods is given without charge, and Seller assumes no obligation or liability for the advice given, or results obtained, all such advice being given and accepted at Buyer’s risk.

**7. PATENTS AND COPYRIGHTS:** Subject to the limitations of the second

paragraph of Section 6, Seller warrants that the Goods sold, except as are made specifically for Buyer according to Buyer’s specifications, do not infringe any valid U.S. patent or copyright in existence as of the date of shipment. This warranty is given upon the condition that Buyer promptly notify Seller of any claim or suit involving Buyer in which such infringement is alleged and cooperate fully with Seller and permit Seller to control completely the defense, settlement or compromise of any such allegation of infringement. Seller’s warranty as to use patents only applies to infringement arising solely out of the inherent operation according to Seller’s specifications and instructions (i) of such Goods, or (ii) of any combination of Goods acquired from Seller in a system designed by Seller. In the event such Goods are held to infringe such a U.S. patent or copyright in such suit, and the use of such Goods is enjoined, or in the case of a compromise or settlement by Seller, Seller shall have the right, at its option and expense, to procure for Buyer the right to continue using such Goods, or replace them with non-infringing Goods, or modify same to become non-infringing, or grant Buyer a credit for the depreciated value of such Goods and accept return of them. In the event of the foregoing, Seller may also, at its option, cancel the agreement as to future deliveries of such Goods, without liability.

**8. EXCUSE OF PERFORMANCE:** Seller shall not be liable for delays in performance or for non-performance due to acts of God; acts of Buyer; war; fire; flood; weather; sabotage; strikes or labor disputes; civil disturbances or riots; governmental requests, restrictions, allocations, laws, regulations, orders or actions; unavailability of or delays in transportation; default of suppliers; or unforeseen circumstances or any events or causes beyond Seller’s reasonable control. Deliveries or other performance may be suspended for an appropriate period of time or canceled by Seller upon notice to Buyer in the event of any of the foregoing, but the balance of the agreement shall otherwise remain unaffected as a result of the foregoing.

If Seller determines that its ability to supply the total demand for the Goods, or to obtain material used directly or indirectly in the manufacture of the Goods, is hindered, limited or made impracticable due to causes set forth in the preceding paragraph, Seller may allocate its available supply of the Goods or such material without obligation to acquire other supplies of any such Goods or material among itself and its purchasers on such basis as Seller determines to be equitable without liability for any failure of performance which may result therefrom.

**9. CANCELLATION:** Unless otherwise agreed in writing by Seller, orders under this agreement may not be canceled by Buyer for any reason.

**10. CHANGES:** Buyer may request changes or additions to the Goods consistent with Seller’s specifications and criteria. In the event such changes or additions are accepted by Seller, Seller may revise the price and dates of delivery.

Seller reserves the right to change designs and specifications for the Goods without prior notice to Buyer, except with respect to Goods being made-to-order for Buyer. Seller shall have no obligation to install or make such change in any Goods manufactured prior to the date of such change.

**11. NUCLEAR/MEDICAL.** GOODS AND SERVICES SOLD HEREUNDER ARE NOT FOR USE IN CONNECTION WITH ANY NUCLEAR, MEDICAL, LIFESUPPORT AND RELATED APPLICATIONS. Buyer accepts goods and services with the foregoing understanding, agrees to communicate the same in writing to any subsequent purchasers or users and to defend, indemnify and hold harmless Seller from any claims, losses, suits, judgments and damages, including incidental and consequential damages, arising from such use, whether the cause of action be based in tort, contract or otherwise, including allegations that the Seller’s liability is based on negligence or strict liability.

**12. BUYER’S COMPLIANCE WITH LAWS:** In connection with the transactions contemplated by this agreement, Buyer is familiar with and shall fully comply with all applicable laws, regulations, rules and other requirements of the United States and of any applicable state, foreign and local governmental body in connection with the purchase, receipt, use, transfer and disposal of the Goods.

**13. EXPORT/IMPORT:** Buyer agrees that all applicable import and export control laws, regulations, orders and requirements, including without limitation those of the United States and the European Union, and the jurisdictions in which the Seller and Buyer are established or from which Goods and Services may be supplied, will apply to their receipt and use. In no event shall Buyer use, transfer, release, import, export, Goods in violation of such applicable laws, regulations, orders or requirements.

**14. TOOLING:** Tool, die, and pattern charges, if any, are in addition to the price of the Goods and are due and payable upon completion of the tool-

ing. All such tools, dies and patterns shall be and remain the property of Seller. Charges for tools, dies, and patterns do not convey to Buyer, title, ownership interest in, or rights to possession or removal, or prevent their use by Seller for other purchasers, except as otherwise expressly provided by Seller and Buyer in writing with reference to this provision.

**15. RETURNED GOODS:** Except as otherwise provided with respect to warranty defects in Section 5, advance written permission to return Goods must be obtained from Seller’s customer service department. Such Goods must be current, unused, catalogued Goods and must be shipped, transportation pre-paid, to the Seller’s specified return location. Returns made without proper written permission will not be accepted by Seller. Credit or exchange for such returned Goods will be at the billing price or current price, whichever is lower, from which will be deducted an inspection, restocking and repacking charge and the cost of any reconditioning. Seller reserves the right to inspect Goods prior to authorizing return.

**16. BUYER SUPPLIED DATA:** To the extent that Seller has been provided by or on behalf of Buyer any specifications, description of operating conditions or other data and information in connection with the selection or design of the Goods, and the actual operating conditions or other circumstances differ from those provided by Buyer and relied upon by Seller, any warranties or other provisions contained herein which are affected by such conditions shall be null and void.

**17. SOFTWARE<sup>1</sup>:** Notwithstanding any other provision herein to the contrary, Seller or applicable third party licensor to Seller shall retain all rights of ownership and title in its respective Software, including without limitation all rights of ownership and title in its respective copies of such Software. Except as otherwise provided herein, Buyer is hereby granted a nonexclusive, nontransferable royalty free license to use the Software incorporated into the Goods solely for purposes of Buyer properly utilizing such Goods purchased from Seller. All other Software shall be furnished to, and used by, Buyer only after execution of Seller’s (or the licensor’s) applicable standard license agreement, the terms of which are incorporated herein by reference.

**18. DRAWINGS:** Seller’s prints and drawings (including without limitation, the underlying technology) furnished by Seller to Buyer in connection with this agreement are the property of Seller and Seller retains all rights, including without limitation, exclusive rights of use, licensing and sale. Possession of such prints or drawings does not convey to Buyer any rights or license, and Buyer shall return all copies (in whatever medium) of such prints or drawings to Seller immediately upon request therefore.

**18. ASSIGNMENT:** Buyer shall not assign its rights or delegate its duties hereunder or any interest herein without the prior written consent of Seller, and any such assignment, without such consent, shall be void.

**19. GENERAL PROVISIONS:** These terms and conditions supersede all other communications, negotiations and prior oral or written statements regarding the subject matter of these terms and conditions. No change, modification, rescission, discharge, abandonment, or waiver of these terms and conditions shall be binding upon the Seller unless made in writing and signed on its behalf by a duly authorized representative of Seller. No conditions, usage of trade, course of dealing or performance, understanding or agreement purporting to modify, vary, explain, or supplement these terms and conditions shall be binding unless hereafter made in writing and signed by the party to be bound, and no modification or additional terms shall be applicable to this agreement by Seller’s receipt, acknowledgment, or acceptance of purchase orders, shipping instruction forms, or other documentation containing terms at variance with or in addition to those set forth herein. Any such modifications or additional terms are specifically rejected and deemed a material alteration hereof. If this document shall be deemed an acceptance of a prior offer by Buyer, such acceptance is expressly conditional upon Buyer’s assent to any additional or different terms set forth herein. No waiver by either party with respect to any breach or default or of any right or remedy, and no course of dealing, shall be deemed to constitute a continuing waiver of any other breach or default or of any other right or remedy, unless such waiver be expressed in writing and signed by the party to be bound. All typographical or clerical errors made by Seller in any quotation, acknowledgment or publication are subject to correction.

The validity, performance, and all other matters relating to the interpretation and effect of this agreement shall be governed by the law of the state of Missouri. Buyer and Seller agree that the proper venue for all actions arising in connection herewith shall be only in Missouri and the parties agree to submit to such jurisdiction. No action, regardless of form, arising out of transactions relating to this contract, may be brought by either party more than two (2) years after the cause of action has accrued. The U.N. Convention on Contracts for the International Sales of Goods shall not apply to this agreement.

<sup>1</sup> Note the definition of “Software” includes “firmware.” (Revision 7/2009)





# EMERSON™

## Network Power

### Connectivity Solutions

#### Emerson Network Power Connectivity Solutions

##### US Headquarters

3000 Lakeside Drive, Ste. 308N  
Bannockburn, IL 60015, USA

##### North America

299 Johnson Avenue, Ste. 100  
Waseca, MN 56093, USA  
Toll Free: 800.247.8256

Tel: 507.833.8822

Fax: 507.833.6287

[ECOrders@Emerson.com](mailto:ECOrders@Emerson.com)

##### Europe, Middle East, Africa

Emerson Network Power Connectivity Solutions, Ltd.  
11 Bilton Road  
Chelmsford  
Essex CM1 2UP  
England

Tel: +44 1245.359.515

Fax: +44 1245.358.938

[EMEACConnectivitySales@Emerson.com](mailto:EMEACConnectivitySales@Emerson.com)

##### Asia Pacific

Emerson Network Power Connectivity Solutions  
(Shanghai) Co., Ltd.

Building 1, No. 800 ShenFu Road  
XinZhuang Industry Park  
Shanghai, China 201108

Tel: +86 21.5442.7668

Fax: +86 21.5442.7628

[APConnectivitySales@Emerson.com](mailto:APConnectivitySales@Emerson.com)

#### About Emerson Network Power Connectivity Solutions

Emerson Network Power Connectivity Solutions, an Emerson business, serves the needs of wireless communications, military, telephony and data networks, CATV security systems, health care and industrial facilities with a full spectrum of RF/microwave and fiber optic connectivity products. For more information, visit [www.EmersonConnectivity.com](http://www.EmersonConnectivity.com)

#### About Emerson

Emerson (NYSE: EMR), based in St. Louis, Missouri (USA), is a global leader in bringing technology and engineering together to provide innovative solutions for customers in industrial, commercial, and consumer markets around the world. The company is comprised of five business segments: Process Management, Industrial Automation, Network Power, Climate Technologies, and Commercial & Residential Solutions. For more information, visit [www.Emerson.com](http://www.Emerson.com)



[www.EmersonConnectivity.com](http://www.EmersonConnectivity.com)

[www.EmersonNetworkPower.com/Connectivity](http://www.EmersonNetworkPower.com/Connectivity)

#### Emerson Network Power

The global leader in enabling business-critical continuity.

- AC Power Systems
- Embedded Power
- Outside Plant
- Connectivity
- Inbound Power
- Precision Cooling
- DC Power Systems
- Integrated Cabinet
- Site Monitoring and Services

Компания «Океан Электроники» предлагает заключение долгосрочных отношений при поставках импортных электронных компонентов на взаимовыгодных условиях!

Наши преимущества:

- Поставка оригинальных импортных электронных компонентов напрямую с производств Америки, Европы и Азии, а так же с крупнейших складов мира;
- Широкая линейка поставок активных и пассивных импортных электронных компонентов (более 30 млн. наименований);
- Поставка сложных, дефицитных, либо снятых с производства позиций;
- Оперативные сроки поставки под заказ (от 5 рабочих дней);
- Экспресс доставка в любую точку России;
- Помощь Конструкторского Отдела и консультации квалифицированных инженеров;
- Техническая поддержка проекта, помощь в подборе аналогов, поставка прототипов;
- Поставка электронных компонентов под контролем ВП;
- Система менеджмента качества сертифицирована по Международному стандарту ISO 9001;
- При необходимости вся продукция военного и аэрокосмического назначения проходит испытания и сертификацию в лаборатории (по согласованию с заказчиком);
- Поставка специализированных компонентов военного и аэрокосмического уровня качества (Xilinx, Altera, Analog Devices, Intersil, Interpoint, Microsemi, Actel, Aeroflex, Peregrine, VPT, Syfer, Eurofarad, Texas Instruments, MS Kennedy, Miteq, Cobham, E2V, MA-COM, Hittite, Mini-Circuits, General Dynamics и др.);

Компания «Океан Электроники» является официальным дистрибьютором и эксклюзивным представителем в России одного из крупнейших производителей разъемов военного и аэрокосмического назначения «JONHON», а так же официальным дистрибьютором и эксклюзивным представителем в России производителя высокотехнологичных и надежных решений для передачи СВЧ сигналов «FORSTAR».



## JONHON

«JONHON» (основан в 1970 г.)

Разъемы специального, военного и аэрокосмического назначения:

(Применяются в военной, авиационной, аэрокосмической, морской, железнодорожной, горно- и нефтедобывающей отраслях промышленности)

«FORSTAR» (основан в 1998 г.)

ВЧ соединители, коаксиальные кабели, кабельные сборки и микроволновые компоненты:

(Применяются в телекоммуникациях гражданского и специального назначения, в средствах связи, РЛС, а так же военной, авиационной и аэрокосмической отраслях промышленности).



Телефон: 8 (812) 309-75-97 (многоканальный)

Факс: 8 (812) 320-03-32

Электронная почта: [ocean@oceanchips.ru](mailto:ocean@oceanchips.ru)

Web: <http://oceanchips.ru/>

Адрес: 198099, г. Санкт-Петербург, ул. Калинина, д. 2, корп. 4, лит. А