



## 16-bit MCU with 256 Kbyte Flash memory and 20 Kbyte RAM

Datasheet – production data

### Features

- 16-bit CPU with DSP functions
  - 50ns instruction cycle time at 40 MHz max CPU clock
  - Multiply/accumulate unit (MAC) 16 x 16-bit multiplication, 40-bit accumulator
  - Enhanced boolean bit manipulations
  - Single-cycle context switching support
- On-chip memories
  - 256 Kbyte Flash memory (32-bit fetch)
  - Single voltage Flash memories with erase/program controller and 100 K erasing/programming cycles.
  - Up to 16 Mbyte linear address space for code and data (5 Mbytes with CAN or I<sup>2</sup>C)
  - 2 Kbyte internal RAM (IRAM)
  - 18 Kbyte extension RAM (XRAM)
  - Programmable external bus configuration & characteristics for different address ranges
  - 5 programmable chip-select signals
  - Hold-acknowledge bus arbitration support
- Interrupt
  - 8-channel peripheral event controller for single cycle interrupt driven data transfer
  - 16-priority-level interrupt system with 56 sources, sampling rate down to 25 ns
- Timers
  - 2 multi-functional general purpose timer units with 5 timers
- Two 16-channel capture/compare units
- Serial channels
  - 2 synch./asynch. serial channels
  - 2 high-speed synchronous channels
  - One I<sup>2</sup>C standard interface
- 24-channel A/D converter
  - 16-channel 10-bit, accuracy  $\pm 2$  LSB
  - 8-channel 10-bit, accuracy  $\pm 5$  LSB
  - 4.85  $\mu$ s minimum conversion time
- 4-channel PWM unit + 4-channel XPWM
- 2 CAN 2.0B interfaces operating on 1 or 2 CAN busses (64 or 2x32 message, C-CAN version)
- Fail-safe protection
  - Programmable watchdog timer
  - Oscillator watchdog
- On-chip bootstrap loader
- Clock generation
  - On-chip PLL with 4 to 8 MHz oscillator
  - Direct or prescaled clock input
- Real-time clock and 32 kHz on-chip oscillator
- Up to 111 general purpose I/O lines
  - Individually programmable as input, output or special function
  - Programmable threshold (hysteresis)
- Idle, power-down and stand-by modes
- Single voltage supply: 5 V  $\pm$  10 % (embedded regulator for 1.8 V core supply)
- Temperature range: -40 to +125 °C

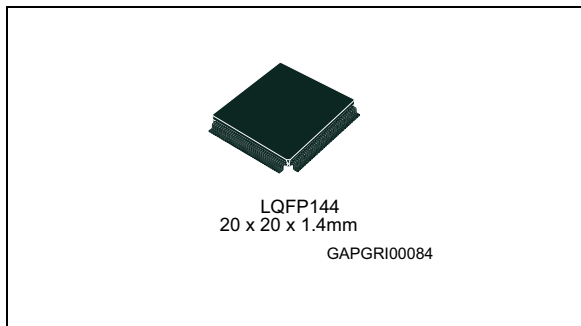

# Contents

- 1 Introduction ..... 11**
  - 1.1 Description ..... 11
  - 1.2 Special characteristics ..... 11
    - 1.2.1 1.2.1 X-peripheral clock gating ..... 11
    - 1.2.2 1.2.2 Improved supply ring ..... 11
- 2 Pin data ..... 13**
- 3 Functional description ..... 20**
- 4 Memory organization ..... 21**
- 5 Internal Flash memory ..... 25**
  - 5.1 Overview ..... 25
  - 5.2 Functional description ..... 25
    - 5.2.1 Structure ..... 25
    - 5.2.2 Modules structure ..... 26
    - 5.2.3 Low power mode ..... 27
  - 5.3 Write operation ..... 28
  - 5.4 Registers description ..... 28
    - 5.4.1 Flash control register 0 low (FCR0L) ..... 28
    - 5.4.2 Flash control register 0 high (FCR0H) ..... 29
    - 5.4.3 Flash control register 1 low (FCR1L) ..... 31
    - 5.4.4 Flash control register 1 high (FCR1H) ..... 31
    - 5.4.5 Flash data register 0 low (FDR0L) ..... 32
    - 5.4.6 Flash data register 0 high (FDR0H) ..... 32
    - 5.4.7 Flash data register 1 low (FDR1L) ..... 33
    - 5.4.8 Flash data register 1 high (FDR1H) ..... 33
    - 5.4.9 Flash address register low (FARL) ..... 33
    - 5.4.10 Flash address register high (FARH) ..... 34
    - 5.4.11 Flash error register (FER) ..... 34
  - 5.5 Protection strategy ..... 35
    - 5.5.1 Protection registers ..... 35
    - 5.5.2 Flash non-volatile write protection I register (FNWVPIR) ..... 36

5.5.3	Flash non-volatile access protection register 0 (FNVAPR0) . . . . .	36
5.5.4	Flash non-volatile access protection register 1 low (FNVAPR1L) . . . . .	36
5.5.5	Flash non-volatile access protection register 1 high (FNVAPR1H) . . . . .	37
5.5.6	X-bus Flash volatile temporary access unprotection register (XFVTAUR0) . . . . .	37
5.5.7	Access protection . . . . .	38
5.5.8	Write protection . . . . .	39
5.5.9	Temporary unprotection . . . . .	39
5.6	Write operation examples . . . . .	39
5.7	Write operation summary . . . . .	42
<b>6</b>	<b>Bootstrap loader . . . . .</b>	<b>43</b>
6.1	Selection among user-code, standard or selective bootstrap . . . . .	43
6.2	Standard bootstrap loader . . . . .	43
6.3	Alternate and selective boot mode (ABM and SBM) . . . . .	44
6.3.1	Activation of the ABM and SBM . . . . .	44
6.3.2	User mode signature integrity check . . . . .	44
6.3.3	Selective boot mode . . . . .	44
<b>7</b>	<b>Central processing unit (CPU) . . . . .</b>	<b>45</b>
7.1	Multiplier-accumulator unit (MAC) . . . . .	46
7.2	Instruction set summary . . . . .	47
7.3	MAC co-processor specific instructions . . . . .	49
<b>8</b>	<b>External bus controller . . . . .</b>	<b>50</b>
<b>9</b>	<b>Interrupt system . . . . .</b>	<b>51</b>
9.1	X-peripheral interrupt . . . . .	53
9.2	Exception and error traps list . . . . .	55
<b>10</b>	<b>Capture/compare (CAPCOM) units . . . . .</b>	<b>56</b>
<b>11</b>	<b>General purpose timer unit . . . . .</b>	<b>58</b>
11.1	GPT1 . . . . .	58
11.2	GPT2 . . . . .	60
<b>12</b>	<b>PWM modules . . . . .</b>	<b>62</b>

<b>13</b>	<b>Parallel ports</b> .....	<b>63</b>
	13.1 Introduction .....	63
	13.2 I/O's special features .....	63
	13.2.1 Open drain mode .....	63
	13.2.2 Input threshold control .....	64
	13.3 Alternate port functions .....	64
<b>14</b>	<b>A/D converter</b> .....	<b>66</b>
<b>15</b>	<b>Serial channels</b> .....	<b>68</b>
	15.1 Asynchronous/synchronous serial interfaces .....	68
	15.2 ASCx in asynchronous mode .....	68
	15.3 ASCx in synchronous mode .....	69
	15.4 High speed synchronous serial interfaces .....	69
<b>16</b>	<b>I<sup>2</sup>C interface</b> .....	<b>71</b>
<b>17</b>	<b>CAN modules</b> .....	<b>72</b>
	17.1 Configuration support .....	72
	17.2 CAN bus configurations .....	72
	17.2.1 Single CAN bus .....	73
	17.2.2 Multiple CAN bus .....	74
	17.2.3 Parallel mode .....	74
<b>18</b>	<b>Real-time clock</b> .....	<b>75</b>
<b>19</b>	<b>Watchdog timer</b> .....	<b>76</b>
<b>20</b>	<b>System reset</b> .....	<b>77</b>
	20.1 Input filter .....	77
	20.2 Asynchronous reset .....	78
	20.3 Synchronous reset (warm reset) .....	83
	20.4 Software reset .....	88
	20.5 Watchdog timer reset .....	89
	20.6 Bidirectional reset .....	90
	20.7 Reset circuitry .....	94

20.8	Reset application examples .....	97
20.9	Reset summary .....	99
<b>21</b>	<b>Power reduction modes .....</b>	<b>102</b>
21.1	Idle mode .....	102
21.2	Power-down mode .....	102
21.2.1	Protected power-down mode .....	103
21.2.2	Interruptible power-down mode .....	103
21.3	Stand-by mode .....	103
21.3.1	Entering stand-by mode .....	104
21.3.2	Exiting stand-by mode .....	105
21.3.3	Real-time clock and stand-by mode .....	105
21.3.4	Power reduction modes summary .....	106
<b>22</b>	<b>Programmable output clock divider .....</b>	<b>107</b>
<b>23</b>	<b>Register set .....</b>	<b>108</b>
23.1	Special function registers .....	108
23.2	X-registers .....	115
23.3	Flash registers ordered by name .....	120
23.4	Identification registers .....	121
<b>24</b>	<b>Electrical characteristics .....</b>	<b>123</b>
24.1	Absolute maximum ratings .....	123
24.2	Recommended operating conditions .....	124
24.3	Power considerations .....	124
24.4	Parameter interpretation .....	125
24.5	DC characteristics .....	126
24.6	Flash characteristics .....	130
24.7	A/D converter characteristics .....	131
24.7.1	Conversion timing control .....	132
24.7.2	A/D conversion accuracy .....	133
24.7.3	Total unadjusted error .....	134
24.7.4	Analog reference pins .....	135
24.8	AC characteristics .....	141
24.8.1	Test waveforms .....	141

24.8.2	Definition of internal timing	141
24.8.3	Clock generation modes	142
24.8.4	Prescaler operation	143
24.8.5	Direct drive	143
24.8.6	Oscillator watchdog (OWD)	143
24.8.7	Phase locked loop (PLL)	144
24.8.8	Voltage controlled oscillator	145
24.8.9	PLL jitter	146
24.8.10	PLL lock/unlock	147
24.8.11	Main oscillator specifications	148
24.8.12	32 kHz oscillator specifications	149
24.8.13	External clock drive XTAL1	150
24.8.14	Memory cycle variables	151
24.8.15	External memory bus timing	152
24.8.16	Multiplexed bus	153
24.8.17	Demultiplexed bus	159
24.8.18	CLKOUT and READY	165
24.8.19	External bus arbitration	167
24.8.20	High-speed synchronous serial interface (SSC) timing	168
<b>25</b>	<b>Package information</b>	<b>172</b>
25.1	ECOPACK® packages	172
25.2	.....LQFP144 mechanical data	172
<b>26</b>	<b>Ordering information</b>	<b>174</b>
<b>27</b>	<b>Revision history</b>	<b>175</b>

## List of tables

Table 1.	Pin description . . . . .	14
Table 2.	Summary of IFlash address range . . . . .	21
Table 3.	Address space reserved for the Flash module . . . . .	25
Table 4.	Flash modules sectorization (read operations). . . . .	26
Table 5.	Flash modules sectorization (write operations or with ROMS1 = '1' or bootstrap mode) . . . . .	26
Table 6.	Control register interface . . . . .	27
Table 7.	Flash control register 0 low. . . . .	29
Table 8.	Flash control register 0 high . . . . .	29
Table 9.	Flash control register 1 low. . . . .	31
Table 10.	Flash control register 1 high . . . . .	31
Table 11.	Banks (BxS) and sectors (BxFy) status bits meaning. . . . .	32
Table 12.	Flash data register 0 low. . . . .	32
Table 13.	Flash data register 0 high . . . . .	32
Table 14.	Flash data register 1 low. . . . .	33
Table 15.	Flash data register 1 high . . . . .	33
Table 16.	Flash address register low . . . . .	33
Table 17.	Flash address register high . . . . .	34
Table 18.	Flash error register . . . . .	34
Table 19.	Flash non-volatile write protection I register . . . . .	36
Table 20.	Flash non-volatile access protection register 0. . . . .	36
Table 21.	Flash non-volatile access protection register 1 low . . . . .	37
Table 22.	Flash non-volatile access protection register 1 high . . . . .	37
Table 23.	X-bus Flash volatile temporary access unprotection register . . . . .	37
Table 24.	Summary of access protection level . . . . .	38
Table 25.	Flash write operations. . . . .	42
Table 26.	ST10F272M boot mode selection . . . . .	43
Table 27.	Standard instruction set summary . . . . .	47
Table 28.	MAC instruction set summary. . . . .	49
Table 29.	Interrupt sources . . . . .	51
Table 30.	X-interrupt detailed mapping. . . . .	54
Table 31.	Trap priorities . . . . .	55
Table 32.	Compare modes . . . . .	57
Table 33.	CAPCOM timer input frequencies, resolutions and periods at 40 MHz . . . . .	57
Table 34.	GPT1 timer input frequencies, resolutions and periods at 40 MHz. . . . .	59
Table 35.	GPT2 timer input frequencies, resolutions and periods at 40 MHz. . . . .	60
Table 36.	PWM unit frequencies and resolutions at 40 MHz CPU clock . . . . .	62
Table 37.	ASC asynchronous baudrates by reload value and deviation errors ( $f_{CPU} = 40$ MHz). . . . .	68
Table 38.	ASC synchronous baudrates by reload value and deviation errors ( $f_{CPU} = 40$ MHz). . . . .	69
Table 39.	Synchronous baudrate and reload values ( $f_{CPU} = 40$ MHz) . . . . .	70
Table 40.	WDTREL reload value ( $f_{CPU} = 40$ MHz) . . . . .	76
Table 41.	Reset event definition . . . . .	77
Table 42.	Reset event. . . . .	99
Table 43.	PORT0 latched configuration for the different reset events . . . . .	100
Table 44.	Power reduction modes summary . . . . .	106
Table 45.	List of special function registers . . . . .	108
Table 46.	List of X-bus registers . . . . .	115
Table 47.	List of Flash registers . . . . .	120
Table 48.	IDMANUF register description . . . . .	121

Table 49.	IDCHIP register description	121
Table 50.	IDMEM register description	122
Table 51.	IDPROG register description	122
Table 52.	Absolute maximum ratings	123
Table 53.	Recommended operating conditions	124
Table 54.	Thermal characteristics	125
Table 55.	Package characteristics	125
Table 56.	DC characteristics	126
Table 57.	Flash characteristics	130
Table 58.	Flash data retention characteristics	131
Table 59.	A/D converter characteristics	131
Table 60.	A/D converter programming	133
Table 61.	On-chip clock generator selections	142
Table 62.	Internal PLL divider mechanism	145
Table 63.	PLL characteristics ( $V_{DD} = 5\text{ V} \pm 10\%$ , $V_{SS} = 0\text{ V}$ , $T_A = -40\text{ to }+125\text{ }^\circ\text{C}$ )	148
Table 64.	Main oscillator characteristics	148
Table 65.	Main oscillator negative resistance (module)	149
Table 66.	32 kHz oscillator characteristics	149
Table 67.	Minimum values of negative resistance (module) for 32 kHz oscillator	150
Table 68.	External clock drive	151
Table 69.	Memory cycle variables	151
Table 70.	Multiplexed bus timings	153
Table 71.	Demultiplexed bus timings	159
Table 72.	CLKOUT and $\overline{\text{READY}}$ timings	165
Table 73.	External bus arbitration timings	167
Table 74.	SSC master mode timings	168
Table 75.	SSC slave mode timings	170
Table 76.	LQFP144 mechanical data	172
Table 77.	Device summary	174
Table 78.	Document revision history	175



## List of figures

Figure 1.	Logic symbol . . . . .	12
Figure 2.	Pin configuration (top view) . . . . .	13
Figure 3.	Block diagram . . . . .	20
Figure 4.	ST10F272M on-chip memory mapping (ROMEN = 1/XADRS = 800Bh - reset value). . . . .	24
Figure 5.	Flash structure . . . . .	25
Figure 6.	Write operation control flow . . . . .	42
Figure 7.	CPU block diagram (MAC unit not included) . . . . .	45
Figure 8.	MAC unit architecture . . . . .	46
Figure 9.	X-interrupt basic structure. . . . .	54
Figure 10.	Block diagram of GPT1. . . . .	59
Figure 11.	Block diagram of GPT2. . . . .	61
Figure 12.	Block diagram of PWM module . . . . .	62
Figure 13.	Connection to single CAN bus via separate CAN transceivers . . . . .	73
Figure 14.	Connection to single CAN bus via common CAN transceivers. . . . .	73
Figure 15.	Connection to two different CAN buses (example, gateway application) . . . . .	74
Figure 16.	Connection to one CAN bus with internal parallel mode enabled. . . . .	74
Figure 17.	Asynchronous power-on reset (EA = 1) . . . . .	80
Figure 18.	Asynchronous power-on reset (EA = 0) . . . . .	81
Figure 19.	Asynchronous hardware reset (EA = 1) . . . . .	82
Figure 20.	Asynchronous hardware reset (EA = 0) . . . . .	83
Figure 21.	Synchronous short/long hardware reset (EA = 1). . . . .	85
Figure 22.	Synchronous short/long hardware reset (EA = 0). . . . .	86
Figure 23.	Synchronous long hardware reset (EA = 1) . . . . .	87
Figure 24.	Synchronous long hardware reset (EA = 0) . . . . .	88
Figure 25.	SW/WDT unidirectional reset (EA = 1) . . . . .	89
Figure 26.	SW/WDT unidirectional reset (EA = 0) . . . . .	90
Figure 27.	SW/WDT bidirectional reset (EA = 1) . . . . .	92
Figure 28.	SW/WDT bidirectional reset (EA = 0) . . . . .	93
Figure 29.	SW/WDT bidirectional reset (EA = 0) followed by a HW reset . . . . .	93
Figure 30.	Minimum external reset circuitry . . . . .	95
Figure 31.	System reset circuit . . . . .	96
Figure 32.	Internal (simplified) reset circuitry . . . . .	96
Figure 33.	Example of software or watchdog bidirectional reset (EA = 1) . . . . .	97
Figure 34.	Example of software or watchdog bidirectional reset (EA = 0) . . . . .	98
Figure 35.	Port0 bits latched into the different registers after reset . . . . .	101
Figure 36.	External RC circuitry on RPD pin . . . . .	103
Figure 37.	Port2 test mode structure . . . . .	129
Figure 38.	Supply current versus the operating frequency (run and idle modes) . . . . .	129
Figure 39.	A/D conversion characteristics . . . . .	135
Figure 40.	A/D converter input pins scheme . . . . .	136
Figure 41.	Charge sharing timing diagram during sampling phase . . . . .	137
Figure 42.	Anti-aliasing filter and conversion rate . . . . .	139
Figure 43.	Input/output waveforms . . . . .	141
Figure 44.	Float waveforms . . . . .	141
Figure 45.	Generation mechanisms for the CPU clock . . . . .	142
Figure 46.	ST10F272M PLL jitter. . . . .	147
Figure 47.	Crystal oscillator and resonator connection diagram . . . . .	149
Figure 48.	32 kHz crystal oscillator connection diagram . . . . .	150

---

Figure 49.	External clock drive XTAL1 . . . . .	151
Figure 50.	External memory cycle: Multiplexed bus, with/without read/write delay, normal ALE. . . . .	155
Figure 51.	External memory cycle: Multiplexed bus, with/without read/write delay, extended ALE. . . . .	156
Figure 52.	External memory cycle: Multiplexed bus, with/without r/w delay, normal ALE, r/w CS. . . . .	157
Figure 53.	External memory cycle: Multiplexed bus, with/without r/w delay, extended ALE, r/w CS. . . . .	158
Figure 54.	External memory cycle: Demultiplexed bus, with/without r/w delay, normal ALE. . . . .	161
Figure 55.	External memory cycle: Demultiplexed bus, with/without r/w delay, extended ALE. . . . .	162
Figure 56.	External memory cycle: Demultipl. bus, with/without r/w delay, normal ALE, r/w CS. . . . .	163
Figure 57.	External memory cycle: Demultiplexed bus, without r/w delay, extended ALE, r/w CS . . . . .	164
Figure 58.	CLKOUT and $\overline{\text{READY}}$ . . . . .	166
Figure 59.	External bus arbitration (releasing the bus) . . . . .	167
Figure 60.	External bus arbitration (regaining the bus) . . . . .	168
Figure 61.	SSC master timing . . . . .	169
Figure 62.	SSC slave timing . . . . .	171
Figure 63.	LQFP144 package dimension . . . . .	172

# 1 Introduction

## 1.1 Description

The ST10F272M device is a new derivative of the STMicroelectronics ST10 family of 16-bit single-chip CMOS microcontrollers.

The ST10F272M combines high CPU performance (up to 20 million instructions per second) with high peripheral functionality and enhanced I/O capabilities. It also provides on-chip high-speed single voltage Flash memory, on-chip high-speed RAM, and clock generation via PLL.

The ST10F272M is processed in 0.18mm CMOS technology. The MCU core and the logic is supplied with a 5 V to 1.8 V on-chip voltage regulator. The part is supplied with a single 5 V supply and I/Os work at 5 V.

The ST10F272M is an optimized version of the ST10F272E, upward compatible with the following set of differences:

- Maximum CPU frequency is 40 MHz
- Reduced range for the Standby Voltage:  $V_{Stby}$  must be in the range of 4.5 to 5.5 V.
- Identification registers: the IDMEM register reflects the Flash type difference and can be used to differentiate the two devices by software
- Improved EMC behavior thanks to the introduction of an internal RC filter on the 5 V for the ballast transistors

## 1.2 Special characteristics

### 1.2.1 1.2.1 X-peripheral clock gating

This new feature have been implemented on the ST10F272M: Once the EINIT instruction has been executed, only the X-peripherals enabled in the XPERCON register will be clocked.

The new feature allows to reduce the power consumption and also should improve the emissions as it avoids to propagate useless clock signals across the device.

### 1.2.2 1.2.2 Improved supply ring

An RC filter has been introduced in the 5 V power supply ring of the ballast transistor. In addition, the supply rings for the internal voltage regulators and the I/Os have been split.

These two modifications should improve the behavior of the device regarding conducted emissions.

Figure 1. Logic symbol

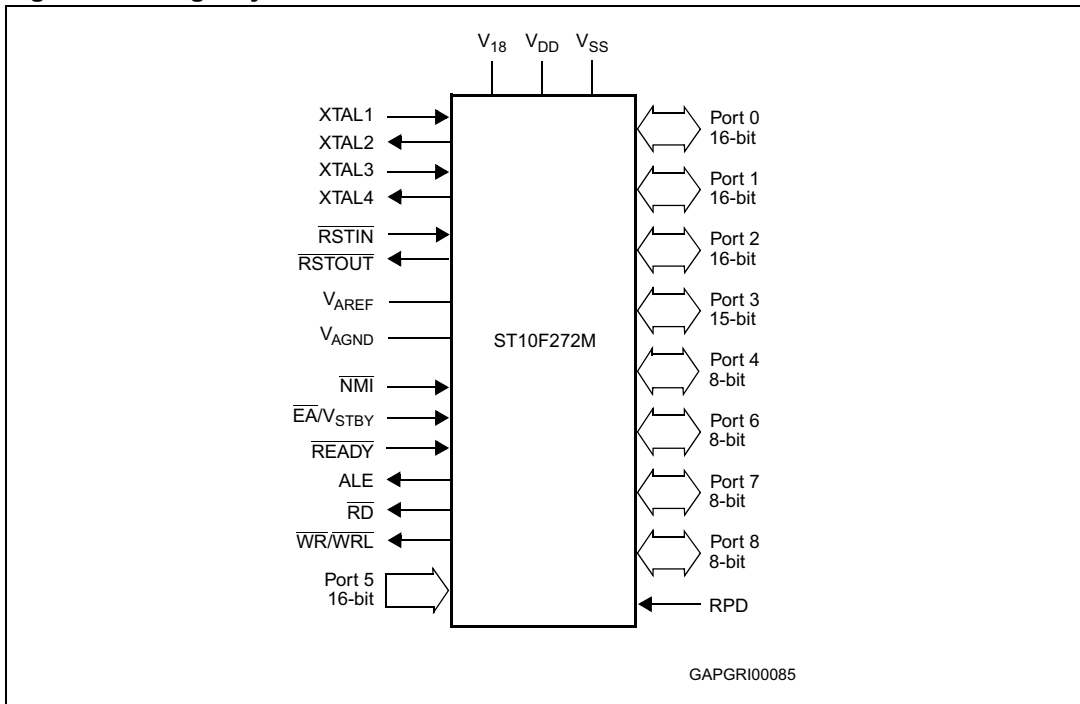

# 2 Pin data

Figure 2. Pin configuration (top view)

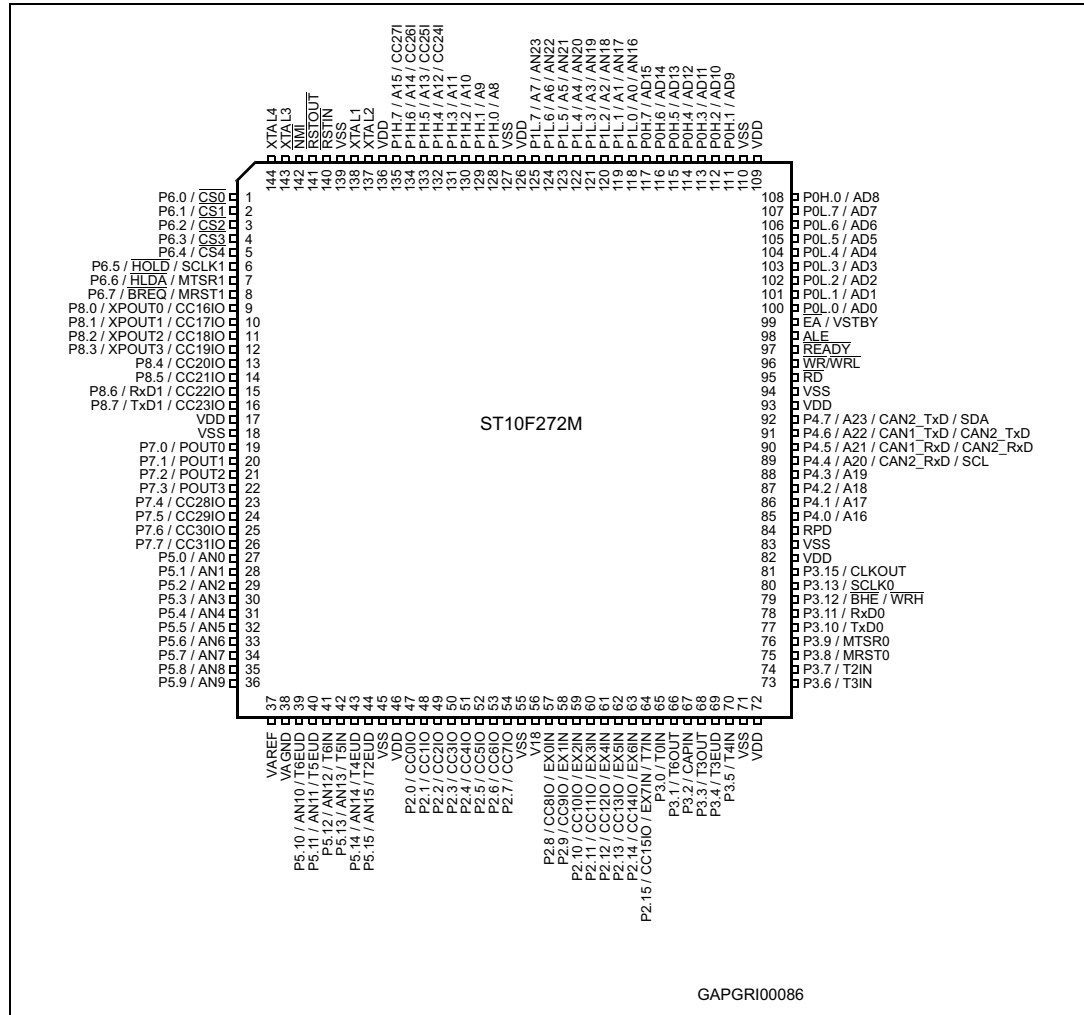

Table 1. Pin description

Symbol	Pin	Type	Function		
P6.0 - P6.7	1 - 8	I/O	8-bit bidirectional I/O port, bitwise programmable for input or output via direction bit. Programming an I/O pin as input forces the corresponding output driver to high impedance state. Port 6 outputs can be configured as push-pull or open drain drivers. The input threshold of port 6 is selectable (TTL or CMOS). The following port 6 pins have alternate functions:		
	1	O	P6.0	$\overline{CS0}$	Chip select 0 output
	...	...	...	...	...
	5	O	P6.4	$\overline{CS4}$	Chip select 4 output
	6	I	P6.5	$\overline{HOLD}$	External master hold request input
		I/O		SCLK1	SSC1: master clock output/slave clock input
	7	O	P6.6	$\overline{HLDA}$	Hold acknowledge output
		I/O		MTSR1	SSC1: master-transmitter/slave-receiver I/O
	8	O	P6.7	$\overline{BREQ}$	Bus request output
I/O			MRST1	SSC1: master-receiver/slave-transmitter I/O	
P8.0 - P8.7	9-16	I/O	8-bit bidirectional I/O port, bitwise programmable for input or output via direction bit. Programming an I/O pin as input forces the corresponding output driver to high impedance state. Port 8 outputs can be configured as push-pull or open drain drivers. The input threshold of port 8 is selectable (TTL or CMOS). The following port 8 pins have alternate functions:		
	9	I/O	P8.0	CC16IO	CAPCOM2: CC16 capture input/compare output
		O		XPWM0	PWM1: channel 0 output
	...	...	...	...	...
	12	I/O	P8.3	CC19IO	CAPCOM2: CC19 capture input/compare output
		O		XPWM0	PWM1: channel 3 output
	13	I/O	P8.4	CC20IO	CAPCOM2: CC20 capture input/compare output
	14	I/O	P8.5	CC21IO	CAPCOM2: CC21 capture input/compare output
	15	I/O	P8.6	CC22IO	CAPCOM2: CC22 capture input compare output
		I/O		RxD1	ASC1: Data input (asynchronous) or I/O (synchronous)
	16	I/O	P8.7	CC23IO	CAPCOM2: CC23 capture input/compare output
		O		TxD1	ASC1: Clock/data output (asynchronous/synchronous)

Table 1. Pin description (continued)

Symbol	Pin	Type	Function		
P7.0 - P7.7	19-26	I/O	8-bit bidirectional I/O port, bitwise programmable for input or output via direction bit. Programming an I/O pin as input forces the corresponding output driver to high impedance state. Port 7 outputs can be configured as push-pull or open drain drivers. The input threshold of port 7 is selectable (TTL or CMOS). The following port 7 pins have alternate functions:		
	19	O	P7.0	POUT0	PWM0: channel 0 output
	...	...	...	...	...
	22	O	P7.3	POUT3	PWM0: channel 3 output
	23	I/O	P7.4	CC28IO	CAPCOM2: CC28 capture input/compare output
	...	...	...	...	...
P5.0 - P5.9 P5.10 - P5.15	27-36 39-44	I I	16-bit input-only port with Schmitt-trigger characteristics. The pins of port 5 can be the analog input channels (up to 16) for the A/D converter, where P5.x equals ANx (Analog input channel x), or they are timer inputs. The input threshold of Port 5 is selectable (TTL or CMOS). The following port 5 pins have alternate functions:		
	39	I	P5.10	T6EUD	GPT2: timer T6 external up/down control input
	40	I	P5.11	T5EUD	GPT2: timer T5 external up/down control input
	41	I	P5.12	T6IN	GPT2: timer T6 count input
	42	I	P5.13	T5IN	GPT2: timer T5 count input
	43	I	P5.14	T4EUD	GPT1: timer T4 external up/down control input
P2.0 - P2.7 P2.8 - P2.15	47-54 57-64	I/O	16-bit bidirectional I/O port, bitwise programmable for input or output via direction bit. Programming an I/O pin as input forces the corresponding output driver to high impedance state. Port 2 outputs can be configured as push-pull or open drain drivers. The input threshold of Port 2 is selectable (TTL or CMOS). The following port 2 pins have alternate functions:		
	47	I/O	P2.0	CC0IO	CAPCOM: CC0 capture input/compare output
	...	...	...	...	...
	54	I/O	P2.7	CC7IO	CAPCOM: CC7 capture input/compare output
	57	I/O	P2.8	CC8IO	CAPCOM: CC8 capture input/compare output
		I		EX0IN	Fast external interrupt 0 input
	...	...	...	...	...
	64	I/O	P2.15	CC15IO	CAPCOM: CC15 capture input/compare output
		I		EX7IN	Fast external interrupt 7 input
	I		T7IN	CAPCOM2: timer T7 count input	

Table 1. Pin description (continued)

Symbol	Pin	Type	Function		
P3.0 - P3.5 P3.6 - P3.13, P3.15	65-70, 73-80, 81	I/O I/O I/O	15-bit (P3.14 is missing) bidirectional I/O port, bitwise programmable for input or output via direction bit. Programming an I/O pin as input forces the corresponding output driver to high impedance state. Port 3 outputs can be configured as push-pull or open drain drivers. The input threshold of port 3 is selectable (TTL or CMOS). The following port 3 pins have alternate functions:		
	65	I	P3.0	T0IN	CAPCOM1: timer T0 count input
	66	O	P3.1	T6OUT	GPT2: timer T6 toggle latch output
	67	I	P3.2	CAPIN	GPT2: register CAPREL capture input
	68	O	P3.3	T3OUT	GPT1: timer T3 toggle latch output
	69	I	P3.4	T3EUD	GPT1: timer T3 external up/down control input
	70	I	P3.5	T4IN	GPT1; timer T4 input for count/gate/reload/capture
	73	I	P3.6	T3IN	GPT1: timer T3 count/gate input
	74	I	P3.7	T2IN	GPT1: timer T2 input for count/gate/reload/capture
	75	I/O	P3.8	MRST0	SSC0: master-receiver/slave-transmitter I/O
	76	I/O	P3.9	MTSR0	SSC0: master-transmitter/slave-receiver I/O
	77	O	P3.10	TxD0	ASC0: clock/data output (asynchronous/synchronous)
	78	I/O	P3.11	RxD0	ASC0: data input (asynchronous) or I/O (synchronous)
	79	O	P3.12	$\overline{\text{BHE}}$	External memory high byte enable signal
				$\overline{\text{WRH}}$	External memory high byte write strobe
	80	I/O	P3.13	SCLK0	SSC0: master clock output/slave clock input
81	O	P3.15	CLKOUT	System clock output (programmable divider on CPU clock)	



Table 1. Pin description (continued)

Symbol	Pin	Type	Function		
P4.0 - P4.7	85-92	I/O	Port 4 is an 8-bit bidirectional I/O port. It is bitwise programmable for input or output via direction bit. Programming an I/O pin as input forces the corresponding output driver to high impedance state. The input threshold is selectable (TTL or CMOS). Port 4.4, 4.5, 4.6 and 4.7 outputs can be configured as push-pull or open drain drivers. In case of an external bus configuration, port 4 can be used to output the segment address lines:		
	85	O	P4.0	A16	Segment address line
	86	O	P4.1	A17	Segment address line
	87	O	P4.2	A18	Segment address line
	88	O	P4.3	A19	Segment address line
	89	O	P4.4	A20	Segment address line
		I		CAN2_RxD	CAN2: receive data input
		I/O		SCL	I <sup>2</sup> C Interface: serial clock
	90	O	P4.5	A21	Segment address line
		I		CAN1_RxD	CAN1: receive data input
		I		CAN2_RxD	CAN2: receive data input
	91	O	P4.6	A22	Segment address line
		O		CAN1_TxD	CAN1: transmit data output
		O		CAN2_TxD	CAN2: transmit data output
	92	O	P4.7	A23	Most significant segment address line
O		CAN2_TxD		CAN2: transmit data output	
I/O		SDA		I <sup>2</sup> C Interface: serial data	
$\overline{RD}$	95	O	External memory read strobe. $\overline{RD}$ is activated for every external instruction or data read access.		
$\overline{WR/WRL}$	96	O	External memory write strobe. In $\overline{WR}$ -mode this pin is activated for every external data write access. In $\overline{WRL}$ mode this pin is activated for low byte data write accesses on a 16-bit bus, and for every data write access on an 8-bit bus. See WRCFG in the SYSCON register for mode selection.		
READY/ READY	97	I	Ready input. The active level is programmable. When the ready function is enabled, the selected inactive level at this pin, during an external memory access, will force the insertion of waitstate cycles until the pin returns to the selected active level.		
ALE	98	O	Address latch enable output. In case of use of external addressing or of multiplexed mode, this signal is the latch command of the address lines.		

Table 1. Pin description (continued)

Symbol	Pin	Type	Function																				
$\overline{EA} / V_{STBY}$	99	I	<p>External access enable pin.</p> <p>A low level applied to this pin during and after reset forces the ST10F272M to start the program from the external memory space. A high level forces ST10F272M to start in the internal memory space. This pin is also used (when Stand-by mode is entered, that is ST10F272M under reset and main <math>V_{DD}</math> turned off) to bias the 32 kHz oscillator amplifier circuit and to provide a reference voltage for the low-power embedded voltage regulator which generates the internal 1.8V supply for the RTC module (when not disabled) and to retain data inside the Stand-by portion of the XRAM (16 Kbyte). It can range from 4.5 to 5.5 V. In running mode, this pin can be tied low during reset without affecting 32 kHz oscillator, RTC and XRAM activities, since the presence of a stable <math>V_{DD}</math> guarantees the proper biasing of all those modules.</p>																				
P0L.0 - P0L.7, P0H.0, P0H.1 - P0H.7	100-107, 108, 111-117	I/O	<p>Two 8-bit bidirectional I/O ports P0L and P0H, bitwise programmable for input or output via direction bit. Programming an I/O pin as input forces the corresponding output driver to high impedance state. The input threshold of Port 0 is selectable (TTL or CMOS). In case of an external bus configuration, PORT0 serves as the address (A) and as the address/data (AD) bus in multiplexed bus modes and as the data (D) bus in demultiplexed bus modes.</p> <p>Demultiplexed bus modes</p> <table border="0"> <tr> <td>Data path width</td> <td>8-bit</td> <td>16-bit</td> </tr> <tr> <td>P0L.0 – P0L.7:</td> <td>D0 – D7</td> <td>D0 - D7</td> </tr> <tr> <td>P0H.0 – P0H.7:</td> <td>I/O</td> <td>D8 - D15</td> </tr> </table> <p>Multiplexed bus modes</p> <table border="0"> <tr> <td>Data path width</td> <td>8-bit</td> <td>16-bit</td> </tr> <tr> <td>P0L.0 – P0L.7:</td> <td>AD0 – AD7</td> <td>AD0 - AD7</td> </tr> <tr> <td>P0H.0 – P0H.7:</td> <td>A8 – A15</td> <td>AD8 - AD15</td> </tr> </table>			Data path width	8-bit	16-bit	P0L.0 – P0L.7:	D0 – D7	D0 - D7	P0H.0 – P0H.7:	I/O	D8 - D15	Data path width	8-bit	16-bit	P0L.0 – P0L.7:	AD0 – AD7	AD0 - AD7	P0H.0 – P0H.7:	A8 – A15	AD8 - AD15
Data path width	8-bit	16-bit																					
P0L.0 – P0L.7:	D0 – D7	D0 - D7																					
P0H.0 – P0H.7:	I/O	D8 - D15																					
Data path width	8-bit	16-bit																					
P0L.0 – P0L.7:	AD0 – AD7	AD0 - AD7																					
P0H.0 – P0H.7:	A8 – A15	AD8 - AD15																					
P1L.0 - P1L.7, P1H.0 - P1H.7	118-125 128-135	I/O	<p>Two 8-bit bidirectional I/O ports P1L and P1H, bitwise programmable for input or output via direction bit. Programming an I/O pin as input forces the corresponding output driver to high impedance state. port1 is used as the 16-bit address bus (A) in demultiplexed bus modes: If at least BUSCONx is configured such that the demultiplexed mode is selected, the pins of port1 are not available for general purpose I/O function. The input threshold of port 1 is selectable (TTL or CMOS). The pins of P1L also serve as the additional (up to eight) analog input channels for the A/D converter, where P1L.x equals ANy (Analog input channel y, where <math>y = x + 16</math>). This additional function has a higher priority on demultiplexed bus function. The following port1 pins have alternate functions:</p>																				
			132	I	P1H.4	CC24IO	CAPCOM2: CC24 capture input																
			133	I	P1H.5	CC25IO	CAPCOM2: CC25 capture input																
			134	I	P1H.6	CC26IO	CAPCOM2: CC26 capture input																
			135	I	P1H.7	CC27IO	CAPCOM2: CC27 capture input																
XTAL1	138	I	XTAL1	Main oscillator amplifier circuit and/or external clock input																			
XTAL2	137	O	XTAL2	Main oscillator amplifier circuit output																			

Table 1. Pin description (continued)

Symbol	Pin	Type	Function	
			To clock the device from an external source, drive XTAL1 while leaving XTAL2 unconnected. Minimum and maximum high/low and rise/fall times specified in the AC characteristics must be observed.	
XTAL3	143	I	XTAL3	32 kHz oscillator amplifier circuit input
XTAL4	144	O	XTAL4	32 kHz oscillator amplifier circuit output
			When 32 kHz oscillator amplifier is not used, to avoid spurious consumption, XTAL3 must be tied to ground while XTAL4 has to be left open. Additionally, bit OFF32 in RTCCON register must be set. 32 kHz oscillator can only be driven by an external crystal, and not by a different clock source.	
$\overline{\text{RSTIN}}$	140	I	Reset input with CMOS Schmitt-trigger characteristics. A low level at this pin for a specified duration while the oscillator is running resets the ST10F272M. An internal pull-up resistor permits power-on reset using only a capacitor connected to $V_{SS}$ . In bidirectional reset mode (enabled by setting bit BDRSTEN in SYSCON register), the $\overline{\text{RSTIN}}$ line is pulled low for the duration of the internal reset sequence.	
$\overline{\text{RSTOUT}}$	141	O	Internal reset indication output. This pin is driven to a low level during hardware, software or watchdog timer reset. $\overline{\text{RSTOUT}}$ remains low until the EINIT (end of initialization) instruction is executed.	
$\overline{\text{NMI}}$	142	I	Non-maskable interrupt input. A high to low transition at this pin causes the CPU to vector to the NMI trap routine. If bit PWDCFG = '0' in SYSCON register, when the PWRDN (power-down) instruction is executed, the $\overline{\text{NMI}}$ pin must be low in order to force the ST10F272M to go into power-down mode. If $\overline{\text{NMI}}$ is high and PWDCFG = '0', when PWRDN is executed, the part will continue to run in normal mode. If not used, pin $\overline{\text{NMI}}$ should be pulled high externally.	
$V_{AREF}$	37	-	A/D converter reference voltage and analog supply	
$V_{AGND}$	38	-	A/D converter reference and analog ground	
RPD	84	-	Timing pin for the return from interruptible power-down mode and synchronous/asynchronous reset selection.	
$V_{DD}$	17, 46, 72,82,93, 109, 126, 136	-	Digital supply voltage = +5 V during normal operation, idle and power-down modes. It can be turned off when stand-by RAM mode is selected.	
$V_{SS}$	18,45, 55,71, 83,94, 110, 127, 139	-	Digital ground	
$V_{18}$	56	-	1.8 V decoupling pin: a decoupling capacitor (typical value of 10 nF, max 100 nF) must be connected between this pin and nearest $V_{SS}$ pin.	



## 4 Memory organization

The memory space of the ST10F272M is configured in a unified memory architecture. Code memory, data memory, registers and I/O ports are organized within the same linear address space of 16 Mbytes. The entire memory space can be accessed bitwise or wordwise. Particular portions of the on-chip memory have additionally been made directly bit addressable.

**IFlash:** 256 Kbytes of on-chip Flash memory. It is divided in eight blocks (B0F0...B0F7) that constitute the bank 0. When bootstrap mode is selected, the test-Flash block B0TF (4 Kbytes) appears at address 00'0000h: refer to [Section 5: Internal Flash memory](#) for more details on memory mapping in boot mode. The summary of address range for IFlash is the following:

**Table 2. Summary of IFlash address range**

Blocks	User mode	Size (bytes)
B0TF	Not visible	4K
B0F0	00'0000h - 00'1FFFh	8K
B0F1	00'2000h - 00'3FFFh	8K
B0F2	00'4000h - 00'5FFFh	8K
B0F3	00'6000h - 00'7FFFh	8K
B0F4	01'8000h - 01'FFFFh	32K
B0F5	02'0000h - 02'FFFFh	64K
B0F6	03'0000h - 03'FFFFh	64K
B0F7	04'0000h - 04'FFFFh	64K

**IRAM:** 2 Kbytes of on-chip internal RAM (dual-port) is provided as a storage for data, system stack, general purpose register banks and code. A register bank is 16 wordwide (R0 to R15) and/or bitwise (RL0, RH0, ..., RL7, RH7) general purpose registers group.

**XRAM:** 16K + 2K bytes of on-chip extension RAM (single port XRAM) is provided as a storage for data, user stack and code. The XRAM is divided into two areas, the first 2 Kbytes named XRAM1 and the second 16 Kbytes named XRAM2, connected to the internal XBUS and are accessed like an external memory in 16-bit demultiplexed bus-mode without wait state or read/write delay (50 ns access at 40 MHz CPU clock). Byte and word accesses are possible.

The XRAM1 address range is 00'E000h - 00'E7FFh if XPEN (bit 2 of SYSCON register), and XRAM1EN (bit 2 of XPERCON register) are set. If XRAM1EN or XPEN is cleared, then any access in the address range 00'E000h - 00'E7FFh will be directed to external memory interface, using the BUSCONx register corresponding to address matching ADDRSELx register.

The XRAM2 address range is the one selected programming XADRS3 register, if XPEN (bit 2 of SYSCON register), and XRAM2EN (bit 3 of XPERCON register) are set. If bit XPEN is cleared, then any access in the address range programmed for XRAM2 will be directed to external memory interface, using the BUSCONx register corresponding to address matching ADDRSELx register.

After reset, the XRAM2 address range is 09'0000h - 09'3FFFh and is mirrored every 16 Kbyte boundary until 0F'FFFFh.

XRAM2 also represents the stand-by RAM, which can be maintained biased through  $\bar{E}A / V_{STBY}$  pin when main supply VDD is turned off. As the XRAM appears like external memory, it cannot be used as system stack or as register banks. The XRAM is not provided for single bit storage and therefore is not bit addressable.

**SFR/ESFR:** 1024 bytes (2 x 512 bytes) of address space is reserved for the special function register areas. SFRs are worldwide registers which are used to control and to monitor the function of the different on-chip units.

**CAN1:** Address range 00'EF00h - 00'EFFh is reserved for the CAN1 module access. The CAN1 is enabled by setting XPEN bit 2 of the SYSCON register and by setting CAN1EN bit 0 of the XPERCON register. Accesses to the CAN module use demultiplexed addresses and a 16-bit data bus (only word accesses are possible). Two wait states give an access time of 100ns at 40 MHz CPU clock. No tri-state wait states are used.

**CAN2:** Address range 00'EE00h - 00'EEFFh is reserved for the CAN2 Module access. The CAN2 is enabled by setting XPEN bit 2 of the SYSCON register and by setting CAN2EN bit 1 of the new XPERCON register. Accesses to the CAN module use demultiplexed addresses and a 16-bit data bus (only word accesses are possible). Two wait states give an access time of 100ns at 40 MHz CPU clock. No tri-state wait states are used.

*Note: If one or the two CAN modules are used, port 4 cannot be programmed to output all eight segment address lines. Thus, only four segment address lines can be used, reducing the external memory space to 5 Mbytes (1 Mbyte per CS line).*

**RTC:** Address range 00'ED00h - 00'EDFFh is reserved for the RTC Module access. The RTC is enabled by setting XPEN bit 2 of the SYSCON register and bit 4 of the XPERCON register. Accesses to the RTC Module use demultiplexed addresses and a 16-bit data bus (only word accesses are possible). Two waitstates give an access time of 100ns at 40 MHz CPU clock. No tristate waitstate is used.

**PWM1:** Address range 00'EC00h - 00'ECFFh is reserved for the PWM1 module access. The PWM1 is enabled by setting XPEN bit 2 of the SYSCON register and bit 6 of the XPERCON register. Accesses to the PWM1 Module use demultiplexed addresses and a 16-bit data bus (only word accesses are possible). Two waitstates give an access time of 100ns at 40 MHz CPU clock. No tristate waitstate is used. Only word access is possible.

**ASC1:** Address range 00'E900h - 00'E9FFh is reserved for the ASC1 module access. The ASC1 is enabled by setting XPEN bit 2 of the SYSCON register and bit 7 of the XPERCON register. Accesses to the ASC1 module use demultiplexed addresses and a 16-bit data bus (only word accesses are possible). Two waitstates give an access time of 100ns at 40 MHz CPU clock. No tristate waitstate is used.

**SSC1:** Address range 00'E800h - 00'E8FFh is reserved for the SSC1 Module access. The SSC1 is enabled by setting XPEN bit 2 of the SYSCON register and bit 8 of the XPERCON register. Accesses to the SSC1 module use demultiplexed addresses and a 16-bit data bus (only word accesses are possible). Two waitstates give an access time of 100ns at 40 MHz CPU clock. No tristate waitstate is used.

**I<sup>2</sup>C:** Address range 00'EA00h - 00'EAFh is reserved for the I<sup>2</sup>C module access. The I<sup>2</sup>C is enabled by setting XPEN bit 2 of the SYSCON register and bit 9 of the XPERCON register. Accesses to the I<sup>2</sup>C module use demultiplexed addresses and a 16-bit data bus (only word accesses are possible). Two waitstates give an access time of 100 ns at 40 MHz CPU clock. No tristate waitstate is used.

**X-miscellaneous:** Address range 00'EB00h - 00'EBFFh is reserved for the access to a set of XBUS additional features. They are enabled by setting XPEN bit 2 of the SYSCON register and bit 10 of the XPERCON register. Accesses to this additional features use demultiplexed addresses and a 16-bit data bus (only word accesses are possible). Two waitstates give an access time of 100ns at 40 MHz CPU clock. No tristate waitstate is used. The following set of features are provided:

- CLKOUT programmable divider
- XBUS interrupt management registers
- ADC multiplexing on P1L register
- Port1L digital disable register for extra ADC channels
- CAN2 multiplexing on P4.5/P4.6
- CAN1-2 main clock prescaler
- Main voltage regulator disable for power-down mode
- TTL/CMOS threshold selection for port0, port1, and port5
- Flash temporary unprotection

In order to meet the needs of designs where more memory is required than is provided on chip, up to 16 Mbytes of external memory can be connected to the microcontroller.

### Visibility of XBUS peripherals

In order to keep the ST10F272M compatible with the ST10F168/ST10F269, the XBUS peripherals can be selected to be visible on the external address / data bus. Different bits for X-peripheral enabling in XPERCON register must be set. If these bits are cleared before the global enabling with XPEN bit in SYSCON register, the corresponding address space, port pins and interrupts are not occupied by the peripherals, thus the peripheral is not visible and not available. Refer to [Chapter 23: Register set on page 108](#).

### XPERCON and X-peripheral clock gating

As already mentioned, the XPERCON register must be programmed to enable the single X-bus modules separately. The XPERCON is a read/write ESFR register.

The new feature of clock gating has been implemented by means of this register: Once the EINIT instruction has been executed, all the peripherals (except RAMs and XMISC) not enabled in the XPERCON register are not be clocked. The clock gating can reduce power consumption and improve EMI when the user doesn't use all X-peripherals.

*Note:* *When the clock has been gated in the disabled peripherals, no reset will be raised once the EINIT instruction has been executed.*

Figure 4. ST10F272M on-chip memory mapping (ROMEN = 1/XADRS = 800Bh - reset value)

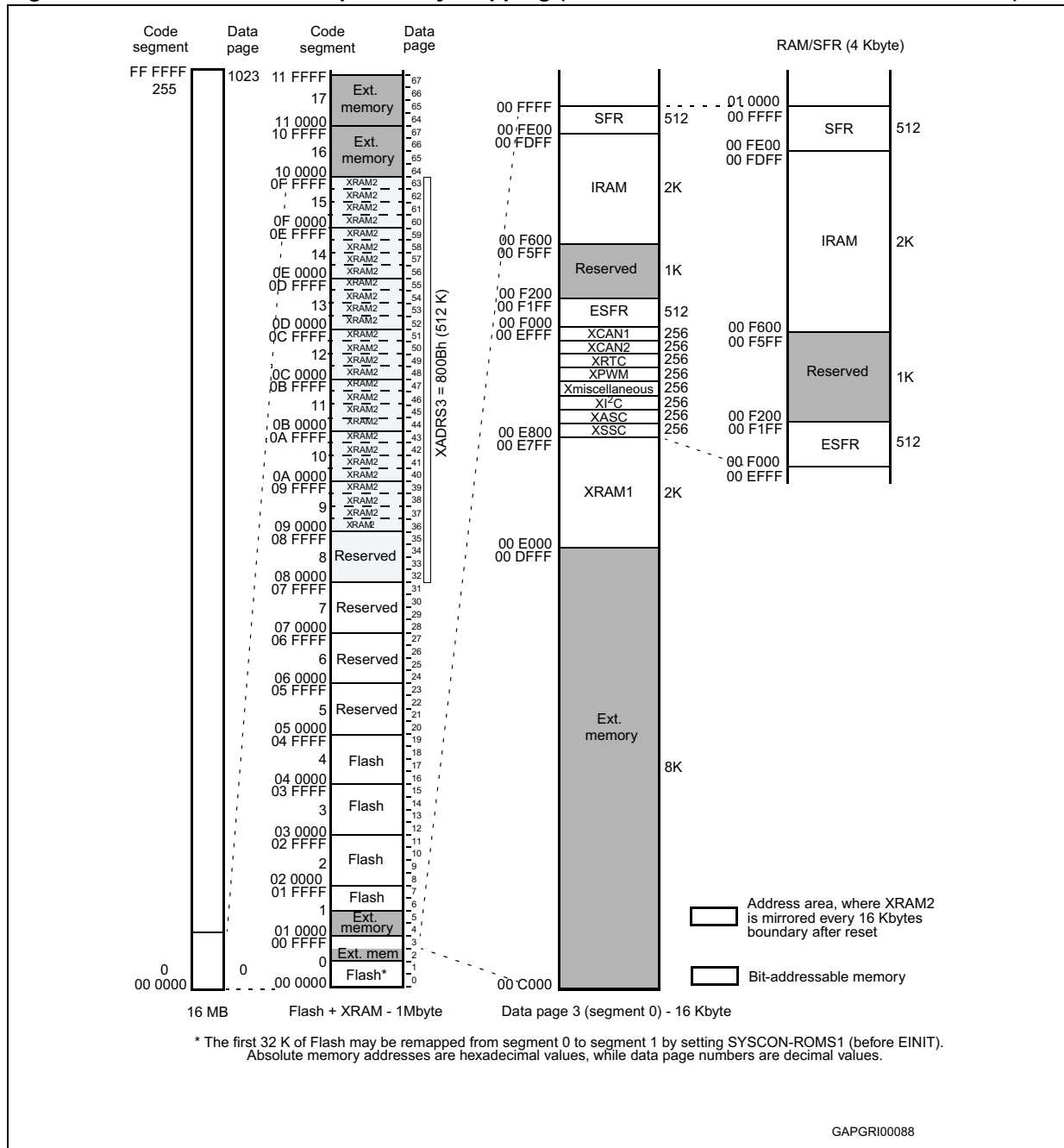



## 5 Internal Flash memory

### 5.1 Overview

The on-chip Flash is composed of one matrix module, 256 Kbytes wide. This module is called IFlash because it is on the ST10 internal bus.

**Figure 5. Flash structure**

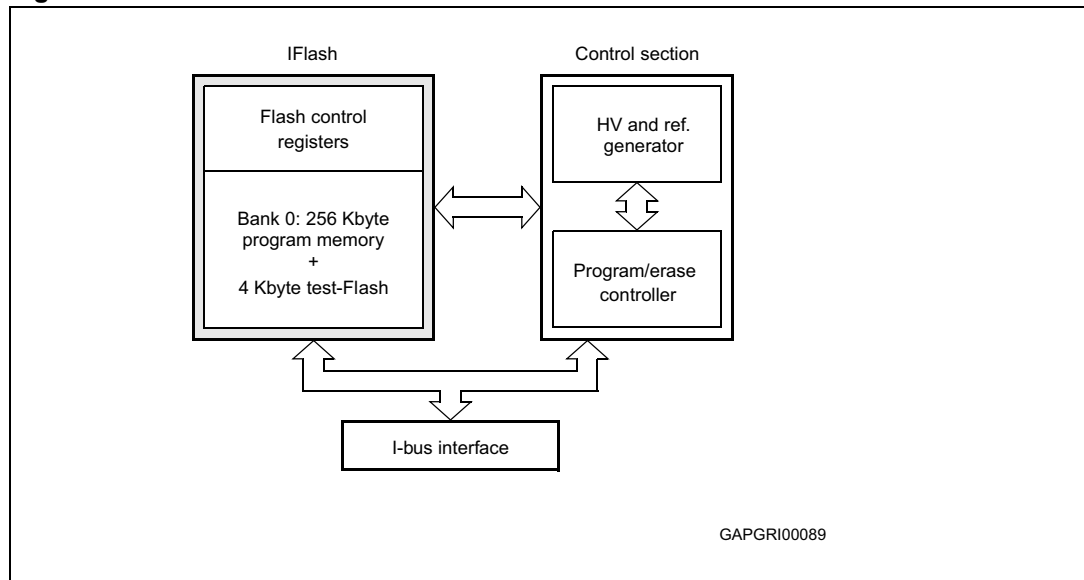

The programming operations of the Flash are managed by an embedded Flash program/erase controller (FPEC). The high voltages needed for program/erase operations are generated internally.

The data bus is 32-bit wide for fetch accesses to IFlash, whereas it is 16-bit wide for read accesses to IFlash control registers. Write accesses are possible only in the IFlash control registers area.

### 5.2 Functional description

#### 5.2.1 Structure

[Table 3](#) below shows the address space reserved for the Flash module.

**Table 3. Address space reserved for the Flash module**

Description	Addresses	Size
IFlash sectors	0x00 0000 to 0x04 FFFF	256 Kbytes
Reserved IBus area	0x05 0000 to 0x07 FFFF	192 Kbytes
Registers and Flash internal reserved area	0x08 0000 to 0x08 FFFF	64 Kbytes

## 5.2.2 Modules structure

The IFlash module is composed of a bank (bank 0) of 256 Kbytes of program memory divided in eight sectors (B0F0...B0F7). Bank 0 also contains a reserved sector named test-Flash.

The addresses from 0x08 0000 to 0x08 FFFF are reserved for the control register interface and other internal service memory space used by the Flash program/erase controller.

The following tables show the memory mapping of the Flash when it is accessed in read mode ([Table 4: Flash modules sectorization \(read operations\)](#)), and when accessed in write or erase mode ([Table 5: Flash modules sectorization \(write operations or with ROMS1 = '1' or bootstrap mode\)](#)).

*Note:* With this second mapping, the first four banks are remapped into code segment 1 (same as obtained setting bit ROMS1 in SYSCON register).

**Table 4. Flash modules sectorization (read operations)**

Bank	Description	Addresses	Size (bytes)	ST10 bus size
B0	Bank 0 Flash 0 (B0F0)	0x0000 0000 - 0x0000 1FFF	8K	32-bit (IBus)
	Bank 0 Flash 1 (B0F1)	0x0000 2000 - 0x0000 3FFF	8K	
	Bank 0 Flash 2 (B0F2)	0x0000 4000 - 0x0000 5FFF	8K	
	Bank 0 Flash 3 (B0F3)	0x0000 6000 - 0x0000 7FFF	8K	
	Bank 0 Flash 4 (B0F4)	0x0001 8000 - 0x0001 FFFF	32K	
	Bank 0 Flash 5 (B0F5)	0x0002 0000 - 0x0002 FFFF	64K	
	Bank 0 Flash 6 (B0F6)	0x0003 0000 - 0x0003 FFFF	64K	
	Bank 0 Flash 7 (B0F7)	0x0004 0000 - 0x0004 FFFF	64K	

**Table 5. Flash modules sectorization (write operations or with ROMS1 = '1' or bootstrap mode)**

Bank	Description	Addresses	Size (bytes)	ST10 bus size
B0	Bank 0 Test-Flash (B0TF)	0x0000 0000 - 0x0000 0FFF	4K	32-bit (IBus)
	Bank 0 Flash 0 (B0F0)	0x0001 0000 - 0x0001 1FFF	8K	
	Bank 0 Flash 1 (B0F1)	0x0001 2000 - 0x0001 3FFF	8K	
	Bank 0 Flash 2 (B0F2)	0x0001 4000 - 0x0001 5FFF	8K	
	Bank 0 Flash 3 (B0F3)	0x0001 6000 - 0x0001 7FFF	8K	
	Bank 0 Flash 4 (B0F4)	0x0001 8000 - 0x0001 FFFF	32K	
	Bank 0 Flash 5 (B0F5)	0x0002 0000 - 0x0002 FFFF	64K	
	Bank 0 Flash 6 (B0F6)	0x0003 0000 - 0x0003 FFFF	64K	
	Bank 0 Flash 7 (B0F7)	0x0004 0000 - 0x0004 FFFF	64K	

[Table 5](#) above refers to the configuration when bit ROMS1 of SYSCON register is set. Refer to the device user manual for more details on the memory mapping during bootstrap mode. In particular, when bootstrap mode is entered:

- Test-Flash is seen and available for code fetches (address 00'0000h)
- User IFlash is only available for read and write accesses
- Write accesses must be made with addresses starting in segment 1 from 01'0000h, whatever ROMS1 bit in SYSCON value
- Read accesses are made in segment 0 or in segment 1 depending of ROMS1 value.

In bootstrap mode, by default ROMS1 = 0, so the first 32 Kbytes of IFlash are mapped in segment 0.

**Example:**

In default configuration, to program address 0, the user must put the value 01'0000h in the FARL and FARH registers but to verify the content of the address 0, a read to 00'0000h must be performed.

The next [Table 6](#) shows the control register interface composition: This set of registers can be addressed by the CPU.

**Table 6. Control register interface**

Name	Description	Addresses	Size
FCR1-0	Flash control registers 1-0	0x0008 0000 - 0x0008 0007	8 bytes
FDR1-0	Flash data registers 1-0	0x0008 0008 - 0x0008 000F	8 bytes
FAR	Flash address registers	0x0008 0010 - 0x0008 0013	4 bytes
FER	Flash error register	0x0008 0014 - 0x0008 0015	2 bytes
FNVWPIR	Flash non-volatile protection i register	0x0008 DFB0 - 0x0008 DFB1	2 bytes
FNVPIR-Mirror	Mirror of Flash non-volatile protection i register	0x0008 DFB4 - 0x0008 DFB5	2 bytes
FNVAPR0	Flash non-volatile access protection register 0	0x0008 DFB8 - 0x0008 DFB9	2 bytes
FNVAPR1	Flash non-volatile access protection register 1	0x0008 DFBC - 0x0008 DFBF	4 bytes
XFVTAUR0	X-bus Flash volatile temporary access unprotection register 0	0x0000 EB50 - 0x0000 EB51	2 bytes

### 5.2.3 Low power mode

The Flash module is automatically switched off executing PWRDN instruction. The consumption is drastically reduced, but exiting this state can require a long time ( $t_{PD}$ ).

Recovery time from power-down mode for the Flash modules is anyway shorter than the main oscillator start-up time. To avoid any problem in restarting to fetch code from the Flash, it is important to size properly the external circuit on RPD pin.

*Note:* **PWRDN instruction must not be executed while a Flash program/erase operation is in progress.**

### 5.3 Write operation

The Flash module has one single register interface mapped in the memory space of the IBus (08'0000h - 08'0015h). All the operations are enabled through four 16-bit control registers: Flash control register 1-0 High/Low (FCR1H/L-FCR0H/L). Eight other 16-bit registers are used to store Flash address and data for program operations (FARH/L and FDR1H/L-FDR0H/L) and write operation error flags (FERH/L). All registers are accessible with 8- and 16-bit instructions (since the IBUS operates in 16-bit mode for read/write accesses to data).

*Note:* The register that controls the temporary unprotection of the Flash is located on the X-bus at address 00'EB50h in the XMiscellaneous register area.

Before accessing the IFlash module (and consequently the Flash register to be used for program/erasing operations), the ROMEN bit in SYSCON register must be set.

**Caution:** During a Flash write operation any attempt to read the Flash itself, that is under modification, will output invalid data (software trap 009Bh). This means that the Flash is not fetchable when a programming operation is active: The write operation commands must be executed from another memory (internal RAM or external memory), as in ST10F269 device. In fact, due to IBus characteristics, it is not possible to perform a write operation on IFlash, when fetching code from IFlash. Direct addressing is not allowed for write accesses to IFlash control registers.

---

**Warning:** During a write operation, when bit LOCK of FCR0 is set, it is forbidden to write into the Flash control registers.

---

#### Power supply drop

If during a write operation the internal low voltage supply drops below a certain internal voltage threshold, any write operation running is suddenly interrupted and the module is reset to read mode. At following power-on, the interrupted Flash write operation must be repeated.

### 5.4 Registers description

#### 5.4.1 Flash control register 0 low (FCR0L)

The Flash control register 0 low (FCR0L) together with the Flash control register 0 high (FCR0H) are used to enable and to monitor all the write operations on the IFlash. The user has no access in write mode to the test-Flash (B0TF). Moreover, the test-Flash block is seen by the user in bootstrap mode only.

FCR0L (0x08 0000)											FCR				Reset value: 0000h	
15	14	13	12	11	10	9	8	7	6	5	4	3	2	1	0	
Reserved											LOCK	Reserved	BSY0	Res.		
											RO	-	RO	-		

**Table 7. Flash control register 0 low**

Bit	Name	Function
4	LOCK	Flash registers access locked When this bit is set, it means that the access to the Flash control registers FCR0H/-FCR1H/L, FDR0H/L-FDR1H/L, FARH/L and FER is locked by the FPEC: any read access to the registers will output invalid data (software trap 009Bh) and any write access will be ineffective. LOCK bit is automatically set when the Flash bit WMS is set. This is the only bit the user can always access to detect the status of the Flash: once it is found low, the rest of FCR0L and all the other Flash registers are accessible by the user as well. <i>Note that FER content can be read when LOCK is low, but its content is updated only when the BSY0 bit is reset.</i>
1	BSY0	Bank 0 busy (IFlash) This bit indicates that a write operation is running on bank 0 (IFlash). It is automatically set when bit WMS is set. Setting protection operation sets bit BSY0 (since protection registers are in this block). When this bit is set, every read access to bank 0 will output invalid data (software trap 009bh), while every write access to the bank will be ignored. At the end of the write operation or during a program or erase suspend this bit is automatically reset and the bank returns to read mode. After a program or erase Resume this bit is automatically set again.

### 5.4.2 Flash control register 0 high (FCR0H)

The Flash control register 0 high (FCR0H) together with the Flash control register 0 low (FCR0L) is used to enable and to monitor all the write operations on the IFlash. The user has no access in write mode to the test-Flash (B0TF). Moreover, the test-Flash block is seen by the user in bootstrap mode only.

FCR0H (0x08 0002)							FCR				Reset value: 0000h				
15	14	13	12	11	10	9	8	7	6	5	4	3	2	1	0
WMS	SUSP	WPG	DWPG	SER	Reserved		SPR	Reserved							
RW	RW	RW	RW	RW	-	-	RW	-							

**Table 8. Flash control register 0 high**

Bit	Name	Function
15	WMS	Write mode start This bit must be set to start every write operation in the Flash module. At the end of the write operation or during a suspend, this bit is automatically reset. To resume a suspended operation, this bit must be set again. It is forbidden to set this bit if bit ERR of FER is high (the operation is not accepted). It is also forbidden to start a new write (program or erase) operation (by setting WMS high) when bit SUSP of FCR0 is high. Resetting this bit by software has no effect.

Table 8. Flash control register 0 high (continued)

Bit	Name	Function
14	SUSP	<p>Suspend</p> <p>This bit must be set to suspend the current program (word or double word) or sector erase operation in order to read data in one of the sectors of the bank under modification or to program data in another bank. The suspend operation resets the Flash bank to normal read mode (automatically resetting bit BSY0). When in program suspend, the Flash module accepts only the following operations: Read and program resume. when in erase suspend the module accepts only the following operations: read, erase resume and program (word or double word; program operations cannot be suspended during erase suspend). To resume a suspended operation, the WMS bit must be set again, together with the selection bit corresponding to the operation to resume (WPG, DWPG, SER).</p> <p><i>Note: It is forbidden to start a new write operation with bit SUSP already set.</i></p>
13	WPG	<p>Word program</p> <p>This bit must be set to select the word (32 bits) program operation in the Flash module. The word program operation can be used to program 0s in place of 1s. The Flash address to be programmed must be written in the FARH/L registers, while the Flash data to be programmed must be written in the FDR0H/L registers before starting the execution by setting bit WMS. WPG bit is automatically reset at the end of the word program operation.</p>
12	DWPG	<p>Double word program</p> <p>This bit must be set to select the double word (64 bits) program operation in the Flash module. The double word program operation can be used to program 0s in place of 1s. The Flash address in which to program (aligned with even words) must be written in the FARH/L registers, while the two Flash data words to be programmed must be written in the FDR0H/L registers (even word) and FDR1H/L registers (odd word) before starting the execution by setting bit WMS. DWPG bit is automatically reset at the end of the double word program operation.</p>
11	SER	<p>Sector erase</p> <p>This bit must be set to select the sector erase operation in the Flash modules. The sector erase operation can be used to erase all the Flash locations to value 0xFF. From 1 to all the sectors of the same bank (excluded test-Flash for bank B0) can be selected to be erased through bits BxFy of FCR1H/L registers before starting the execution by setting bit WMS. It is not necessary to preprogram the sectors to 0x00, because this is done automatically. SER bit is automatically reset at the end of the sector erase operation.</p>
8	SPR	<p>Set protection</p> <p>This bit must be set to select the set protection operation. The set protection operation can be used to program 0s in place of 1s in the Flash non-volatile protection registers. The Flash address in which to program must be written in the FARH/L registers, while the Flash data to be programmed must be written in the FDR0H/L before starting the execution by setting bit WMS. A sequence error is flagged by bit SEQER of FER if the address written in FARH/L is not in the range of 0x0E8FB0 to 0x08DFBF. SPR bit is automatically reset at the end of the set protection operation.</p>

### 5.4.3 Flash control register 1 low (FCR1L)

The Flash control register 1 Low (FCR1L), together with Flash control register 1 high (FCR1H), is used to select the sectors to erase, or during any write operation to monitor the status of each sector and bank.

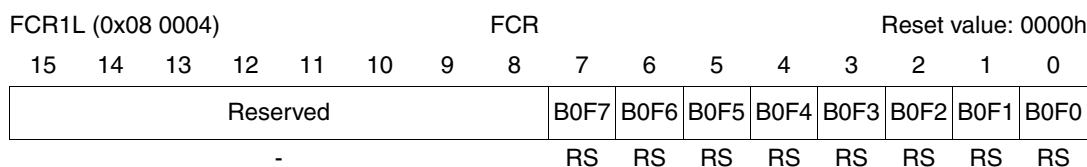
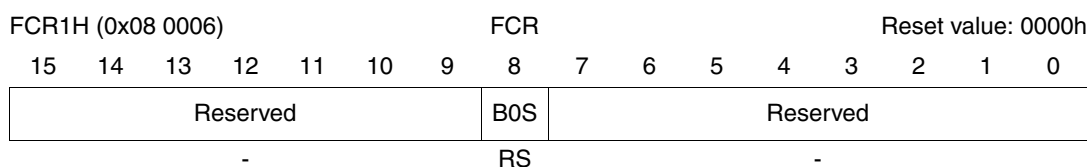

**Table 9. Flash control register 1 low**

Bit	Name	Function
7:0	B0F[7:0]	Bank 0 IFlash sectors 7-0 status These bits must be set during a sector erase operation to select the sectors to erase in bank 0. Moreover, during any erase operation, these bits are automatically set and give the status of the eight sectors of Bank 0 (B0F7-B0F0). The meaning of B0Fy bit for sector y of bank 0 is given in <a href="#">Table 11: Banks (BxS) and sectors (BxFy) status bits meaning</a> . These bits are automatically reset at the end of a write operation if no errors are detected.

### 5.4.4 Flash control register 1 high (FCR1H)

The Flash control register 1 high (FCR1H), together with Flash control register 1 low (FCR1L), is used to select the sectors to erase, or during any write operation to monitor the status of each sector and bank.



**Table 10. Flash control register 1 high**

Bit	Name	Function
8	B0S	Bank 0 status (IFlash) During any erase operation, this bit is automatically modified and gives the status of the bank 0. The meaning of B0Fy bit for sector y of bank 0 is given in <a href="#">Table 11: Banks (BxS) and sectors (BxFy) status bits meaning</a> . This bit is automatically reset at the end of an erase operation if no errors are detected.

During any erase operation, this bit is automatically set and gives the status of the bank 0. The meaning of B0Fy bit for sector y of bank 0 is given in [Table 11: Banks \(BxS\) and sectors \(BxFy\) status bits meaning](#). These bits are automatically reset at the end of an erase operation if no errors are detected.

**Table 11. Banks (BxS) and sectors (BxFy) status bits meaning**

ERR	SUSP	B0S = 1 meaning	B0Fy = 1 meaning
1	-	Erase error in bank0	Erase error in sector y of bank0
0	1	Erase suspended in bank0	Erase suspended in sector y of bank0
0	0	Don't care	Don't care

### 5.4.5 Flash data register 0 low (FDR0L)

During program operations, the Flash address registers (FARH/L) are used to store the Flash address in which to program and the Flash data registers (FDR1H/L-FDR0H/L) are used to store the Flash data to program.

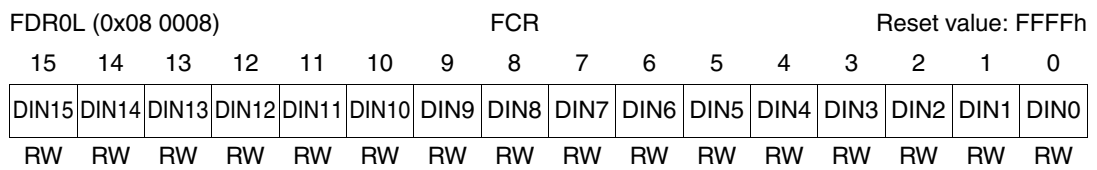

**Table 12. Flash data register 0 low**

Bit	Name	Function
15:0	DIN[15:0]	Data Input 15:0 These bits must be written with the data to program the Flash with the following operations: Word program (32-bit), double word program (64-bit) and set protection.

### 5.4.6 Flash data register 0 high (FDR0H)

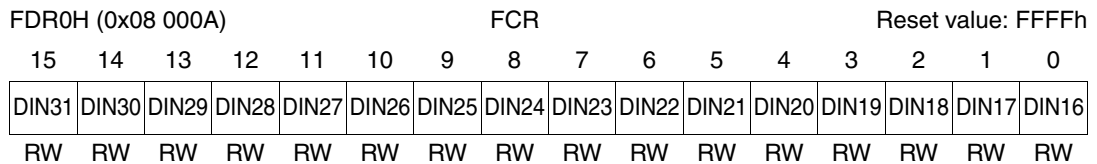
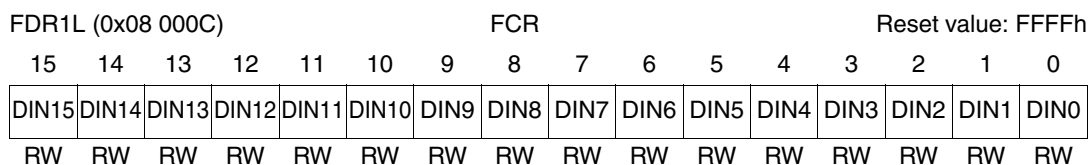

**Table 13. Flash data register 0 high**

Bit	Name	Function
15:0	DIN[31:16]	Data input 31:16 These bits must be written with the data to program the Flash with the following operations: Word program (32-bit), double word program (64-bit) and set protection.



### 5.4.7 Flash data register 1 low (FDR1L)



**Table 14. Flash data register 1 low**

Bit	Name	Function
15:0	DIN[15:0]	Data Input 15:0 These bits must be written with the data to program the Flash with the following operations: Word program (32-bit), double word program (64-bit) and set protection.

### 5.4.8 Flash data register 1 high (FDR1H)

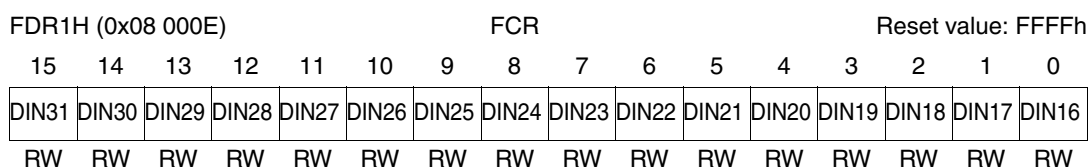

**Table 15. Flash data register 1 high**

Bit	Name	Function
15:0	DIN[31:16]	Data input 31:16 These bits must be written with the data to program the Flash with the following operations: Word program (32-bit), double word program (64-bit) and set protection.

### 5.4.9 Flash address register low (FARL)

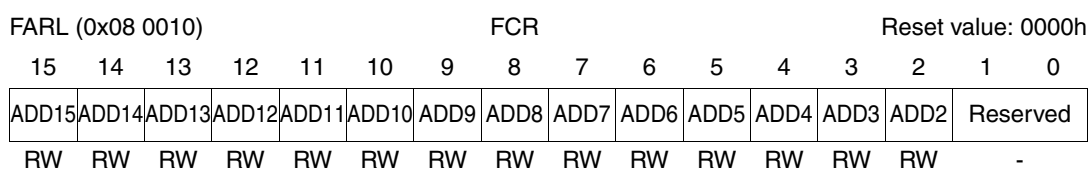

**Table 16. Flash address register low**

Bit	Name	Function
15:2	ADD[15:2]	Address 15:2 These bits must be written with the address of the Flash location to program in the following operations: Word program (32-bit) and double word program (64-bit). in double word program bit add2 must be written to '0'.

### 5.4.10 Flash address register high (FARH)

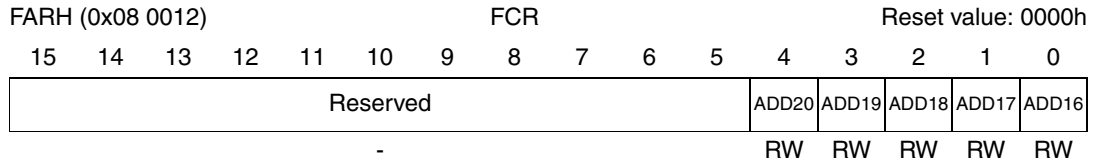
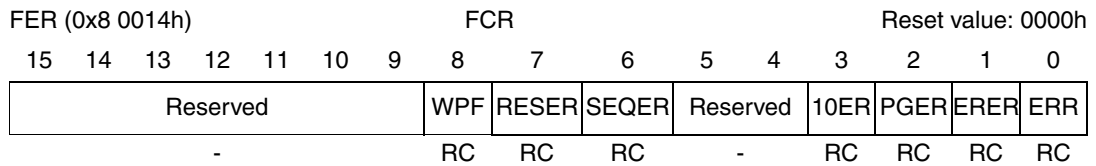

**Table 17. Flash address register high**

Bit	Name	Function
4:0	ADD[20:16]	Address 20:16 These bits must be written with the address of the Flash location to program in the following operations: Word program and double word program.

### 5.4.11 Flash error register (FER)

The Flash error register, as well as all the other Flash registers, can be read only once the LOCK bit of register FCR0L is low. Nevertheless, the FER content is updated after completion of the Flash operation, that is, when BSY0 is reset. Therefore, the FER content can only be read once the LOCK and BSY0 bits are cleared.



**Table 18. Flash error register**

Bit	Name	Function
0	ERR	Write error This bit is automatically set when an error occurs during a Flash write operation or when a bad write operation setup is done. Once the error has been discovered and understood, ERR bit must be software reset.
1	ERER	Erase error This bit is automatically set when an erase error occurs during a Flash write operation. This error is due to a real failure of a Flash cell, that can no more be erased. This kind of error is fatal and the sector where it occurred must be discarded. This bit has to be software reset.
2	PGER	Program error This bit is automatically set when a program error occurs during a Flash write operation. This error is due to a real failure of a Flash cell, that can no more be programmed. The word where this error occurred must be discarded. This bit has to be software reset.
3	10ER	1 over 0 error This bit is automatically set when trying to program at 1 bits previously set at 0 (this does not happen when programming the protection bits). This error is not due to a failure of the Flash cell, but only flags that the desired data has not been written. This bit has to be software reset.

**Table 18. Flash error register (continued)**

Bit	Name	Function
6	SEQER	Sequence error This bit is automatically set when the control registers (FCR1H/L-FCR0H/L, FARH/L, FDR1H/L-FDR0H/L) are not correctly filled to execute a valid Write Operation. In this case no write operation is executed. This bit has to be software reset.
7	RESER	Resume error This bit is automatically set when a suspended program or erase operation is not resumed correctly due to a protocol error. In this case the suspended operation is aborted. This bit has to be software reset.
8	WPF	Write protection flag This bit is automatically set when trying to program or erase in a sector write protected. In case of multiple sector erase, the not protected sectors are erased, while the protected sectors are not erased and bit WPF is set. This bit has to be software reset.

## 5.5 Protection strategy

The protection bits are stored in non-volatile Flash cells inside IFlash module, that are read once at reset and stored in four volatile registers. Before they are read from the non-volatile cells, all the available protections are forced active during reset.

The protections can be programmed using the set protection operation (see Flash control registers paragraph), that can be executed from all the internal or external memories except from the Flash itself.

Two kind of protections are available: write protections to avoid unwanted writings and access protections to avoid piracy. In next paragraphs all different level of protections are shown, and architecture limitations are highlighted as well.

### 5.5.1 Protection registers

The four non-volatile protection registers are one time programmable for the user.

One register (FNVWPIR) is used to store the write protection fuses respectively for each sector IFlash module. The other three registers (FNVAPR0 and FNVAPR1L/H) are used to store the access protection fuses.

### 5.5.2 Flash non-volatile write protection I register (FNVWPIR)

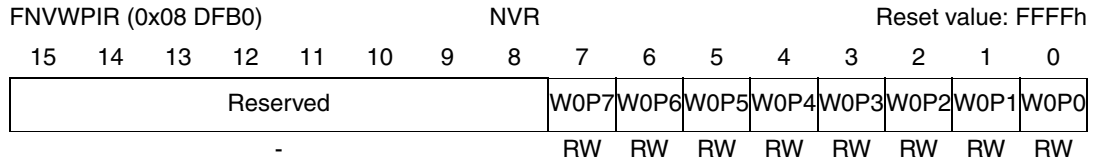

**Table 19. Flash non-volatile write protection I register**

Bit	Name	Function
7:0	WOP[7:0]	Write protection bank 0/sectors 7-0 (IFlash) These bits, if programmed at 0, disable any write access to the sectors of bank 0 (IFlash)

### 5.5.3 Flash non-volatile access protection register 0 (FNVAPR0)

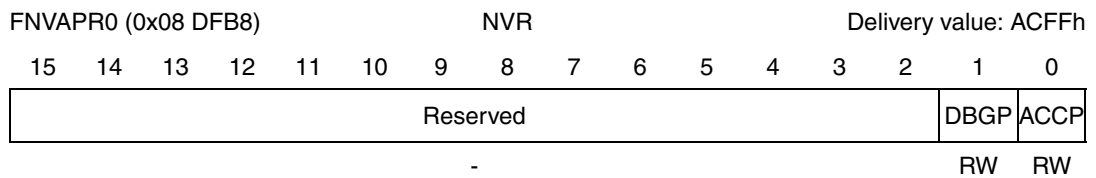

**Table 20. Flash non-volatile access protection register 0**

Bit	Name	Function
0	ACCP	Access protection This bit, if programmed at 0, disables any access (read/write) to data mapped inside IFlash module address space, unless the current instruction is fetched from IFlash.
1	DBGP	Debug protection This bit, if erased at 1, can be used to by-pass all the protections using the debug features through the test interface. If programmed at 0, on the contrary, all the debug features, the test interface and all the Flash test modes are disabled. Even STMicroelectronics will not be able to access the device to run any eventual failure analysis.

### 5.5.4 Flash non-volatile access protection register 1 low (FNVAPR1L)

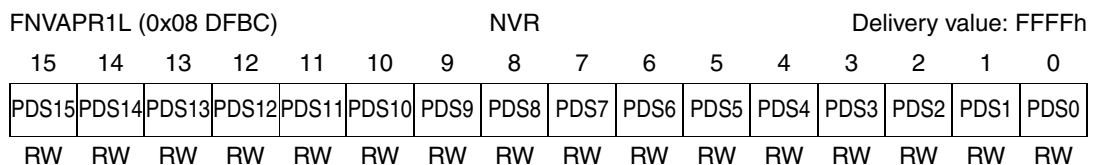

**Table 21. Flash non-volatile access protection register 1 low**

Bit	Name	Function
15:0	PDS[15:0]	Protections disable 15-0 If bit PDSx is programmed at 0 and bit PENx is erased at 1, the action of bit ACCP is disabled. Bit PDS0 can be programmed at 0 only if both bits DBGP and ACCP have already been programmed at 0. Bit PDSx can be programmed at 0 only if bit PENx-1 has already been programmed at 0.

### 5.5.5 Flash non-volatile access protection register 1 high (FNVAPR1H)

FNVAPR1H (0x08 DFBE) NVR Delivery value: FFFFh

15	14	13	12	11	10	9	8	7	6	5	4	3	2	1	0
PEN15	PEN14	PEN13	PEN12	PEN11	PEN10	PEN9	PEN8	PEN7	PEN6	PEN5	PEN4	PEN3	PEN2	PEN1	PEN0
RW	RW	RW	RW	RW	RW	RW	RW	RW	RW	RW	RW	RW	RW	RW	RW

**Table 22. Flash non-volatile access protection register 1 high**

Bit	Name	Function
15:0	PEN[15:0]	Protections enable 15-0 If bit PENx is programmed at 0 and bit PDSx+1 is erased at 1, the action of bit ACCP is enabled again. Bit PENx can be programmed at 0 only if bit PDSx has already been programmed at 0.

### 5.5.6 X-bus Flash volatile temporary access unprotection register (XFVTAUR0)

XFVTAUR0 (0x00 EB50) NVR Reset value: 0000h

15	14	13	12	11	10	9	8	7	6	5	4	3	2	1	0
Reserved															TAUB
															RW

**Table 23. X-bus Flash volatile temporary access unprotection register**

Bit	Name	Function
0	TAUB	Temporary access unprotection bit If this bit is set to 1, the access protection is temporary disabled. The fact that this bit can be written only while executing from IFlash guarantees that only a code executed in IFlash can unprotect the IFlash when it is access protected.

### 5.5.7 Access protection

The IFlash module has one level of access protection (access to data both in reading and writing).

When bit ACCP of FNVAPR0 is programmed at 0 and bit TAUB in XFVTAUR0 is set at 0, the IFlash module becomes access protected (data in the IFlash module can be read only if the current execution is from the IFlash module itself).

Trying to read into the access protected Flash from internal RAM or external memories will output a dummy data (software trap 009Bh).

When the Flash module is protected in access, data access through PEC transfers is also forbidden. To read/write data through PEC in a protected bank, first it is necessary to temporarily unprotect the Flash module.

To enable access protection, the following sequence of operations is recommended:

- Execution from external memory or internal RAM
- Program TAUB bit at 1 in XFVTAUR0 register
- Program ACCP bit in FNVAPR0 to 0 using set protection operation
- Program TAUB bit at 0 in XFVTAUR0 register
- Access protection is active when both ACCP bit and TAUB bit are set to 0

Protection can be permanently disabled by programming bit PDS0 of FNVAPR1H, in order to analyze rejects. Protection can be permanently enabled again by programming bit PEN0 of FNVAPR1L. The action to disable and enable again access protections in a permanent way can be executed a maximum of 16 times. To execute the above described operations, the Flash has to be temporarily unprotected (see [Section 5.5.9: Temporary unprotection](#)).

Trying to write into the access protected Flash from internal RAM or external memories will be unsuccessful. Trying to read into the access protected Flash from internal RAM or external memories will output dummy data (software trap 0x009Bh).

When the Flash module is protected in access, data access through PEC of a peripheral is also forbidden. To read/write data in PEC mode from/to a protected bank, it is necessary to first temporarily unprotect the Flash module.

The following table summarizes all possible access protection levels: In particular, it shows what is possible and not possible to do when fetching from a memory (see fetch location column) supposing all possible access protections are enabled.

**Table 24. Summary of access protection level**

Fetch location	Read IFlash / jump to IFlash	Read XRAM or external memory/ jump to XRAM or external memory	Read Flash registers	Write Flash registers
Fetching from IFlash	Yes/yes	Yes/yes	Yes	No
Fetching from IRAM	No/yes	Yes/yes	No	No
Fetching from XRAM	No/yes	Yes/yes	No	No
Fetching from external memory	No/yes	Yes/yes	No	No

When the access protection is enabled, Flash registers can not be written, so no program/erase operation can be run on IFlash. To enable the access to registers again, the temporary access unprotection procedure has to be followed (see [Section 5.5.9](#)).

### 5.5.8 Write protection

The Flash modules have one level of write protections: each sector of each bank of each Flash module can be software write protected by programming at 0 the related bit WOPx in FNVWPIRL register.

### 5.5.9 Temporary unprotection

Bits WOPx of FNVWPIRL can be temporarily unprotected by executing the set protection operation and by writing 1 into these bits.

To restore the write protection bits it is necessary to reset the microcontroller or to execute a set protection operation and write 0 into the desired bits.

In reality, when a temporary write unprotection operation is executed, the corresponding volatile register is written to 1, while the non-volatile registers bits previously written to 0 (for a protection set operation), will continue to maintain the 0. For this reason, the user software must be in charge to track the current write protection status (for instance using a specific RAM area), it is not possible to deduce it by reading the non-volatile register content (a temporary unprotection cannot be detected).

To temporarily unprotect the Flash when the access protection is active, it is necessary to set to '1' the bit TAUB in XFVTAUR0. This bit can be set to '1' only while executing from Flash: In this way only an instruction executed from Flash can unprotect the Flash itself.

To restore the access protection, it is necessary to reset the microcontroller or to write at 0 the bit TAUB in XFVTAUR0.

## 5.6 Write operation examples

In the following, examples for each kind of Flash write operation are presented.

*Note: The write operation commands must be executed from another memory (internal RAM or external memory), as in ST10F269 device. In fact, due to IBus characteristics, it is not possible to perform write operation in Flash while fetching code from Flash.*

*Moreover, direct addressing is not allowed for write accesses to IFlash control registers. This means that both address and data for a writing operation must be loaded in one of ST10 GPR register (R0...R15).*

*Write operation on IBus registers is 16 bits wide.*

### Example of indirect addressing mode

```
MOV  RWm, #ADDRESS;      /*Load Add in RWm*/
MOV  RWn, #DATA;         /*Load Data in RWn*/
MOV  [RWm], RWn;         /*Indirect addressing*/
```

### Word program

Example: 32-bit word program of data 0xAAAAAAAA at address 0x025554

```
FCR0H |= 0x2000;         /*Set WPG in FCR0H*/
FARL  = 0x5554;         /*Load Add in FARL*/
FARH  = 0x0002;         /*Load Add in FARH*/
FDR0L = 0xAAAA;         /*Load Data in FDR0L*/
FDR0H = 0xAAAA;         /*Load Data in FDR0H*/
FCR0H |= 0x8000;         /*Operation start*/
```

### Double word program

Example: Double word program (64-bit) of data 0x55AA55AA at address 0x035558 and data 0xAA55AA55 at address 0x03555C in IFlash module.

```
FCR0H  |= 0x1000;        /*Set DWPG/
FARL    = 0x5558;        /*Load Add in FARL*/
FARH    = 0x0003;        /*Load Add in FARH*/
FDR0L   = 0x55AA;        /*Load Data in FDR0L*/
FDR0H   = 0x55AA;        /*Load Data in FDR0H*/
FDR1L   = 0xAA55;        /*Load Data in FDR1L*/
FDR1H   = 0xAA55;        /*Load Data in FDR1H*/
FCR0H  |= 0x8000;        /*Operation start*/
```

Double word program is always performed on the double word aligned on an even word: bit ADD2 of FARL is ignored.

### Sector erase

Example: Sector erase of sectors B0F1 and B0F0 of Bank 0 in IFlash module.

```
FCR0H  |= 0x0800;        /*Set SER in FCR0H*/
FCR1L  |= 0x0003;        /*Set B0F1, B0F0*/
FCR0H  |= 0x8000;        /*Operation start*/
```

### Suspend and resume

Word program, double word program, and sector erase operations can be suspended in the following way:

```
FCR0H  |= 0x4000;        /*Set SUSP in FCR0H*/
```

Then the operation can be resumed in the following way:

```
FCR0H  |= 0x0800;        /*Set SER in FCR0H*/
FCR0H  |= 0x8000;        /*Operation resume*/
```

Before resuming a suspended erase, FCR1H/FCR1L must be read to check if the erase is already completed (FCR1H = FCR1L = 0x0000 if erase is complete). Original setup of select operation bits in FCR0H/L must be restored before the operation resume, otherwise the operation is aborted and bit RESER of FER is set.



## Set protection

**Example 1:** Enable write protection of sectors B0F3-0 of Bank 0 in IFlash module.

```
FCR0H  |= 0x0100;      /*Set SPR in FCR0H*/
FARL   = 0xDFB4;      /*Load Add of register FNVWPIR in FARL*/
FARH   = 0x0008;      /*Load Add of register FNVWPIR in FARH*/
FDR0L  = 0xFFFF0;     /*Load Data in FDR0L*/
FDR0H  = 0xFFFF;     /*Load Data in FDR0H*/
FCR0H  |= 0x8000;     /*Operation start*/
```

**Example 2:** Enable access and debug protection.

```
FCR0H  |= 0x0100;      /*Set SPR in FCR0H*/
FARL   = 0xDFB8;      /*Load Add of register FNVAPR0 in FARL*/
FARH   = 0x0008;      /*Load Add of register FNVAPR0 in FARH*/
FDR0L  = 0xFFFC;     /*Load Data in FDR0L*/
FCR0H  |= 0x8000;     /*Operation start*/
```

**Example 3:** Disable in a permanent way access and debug protection.

```
XFVTAUR0 = 0x0001;     /*Set TAUB in XFVTAUR0*/
FCR0H    |= 0x0100;     /*Set SPR in FCR0H*/
FARL     = 0xDFBC;     /*Load Add of register FNVAPR1L in FARL*/
FARH     = 0x0008;     /*Load Add of register FNVAPR1L in FARH*/
FDR0L    = 0xFFFE;     /*Load Data in FDR0L for clearing PDS0*/
FCR0H    |= 0x8000;     /*Operation start*/
```

**Example 4:** Enable again in a permanent way access and debug protection, after having disabled them.

```
XFVTAUR0 = 0x0001;     /*Set TAUB in XFVTAUR0*/
FCR0H    |= 0x0100;     /*Set SPR in FCR0H*/
FARL     = 0xDFBC;     /*Load Add register FNVAPR1H in FARL*/
FARH     = 0x0008;     /*Load Add register FNVAPR1H in FARH*/
FDR0H    = 0xFFFE;     /*Load Data in FDR0H for clearing PEN0*/
FCR0H    |= 0x8000;     /*Operation start*/
XFVTAUR0 = 0x0000;     /*Reset TAUB in XFVTAUR0*/
```

Disable and re-enable of access and debug protection in a permanent way (as shown by examples 3 and 4) can be done for a maximum of 16 times.

## 5.7 Write operation summary

In general, each write operation is started through a sequence of three steps:

1. The first instruction is used to select the desired operation by setting its corresponding selection bit in the Flash control register 0.
2. The second step is the definition of the address and data for programming or the sectors or banks to erase.
3. The last instruction is used to start the write operation, by setting the start bit WMS in the FCR0.

Once selected, but not yet started, one operation can be canceled by resetting the operation selection bit.

Available Flash module write operations are summarized in the following [Table 25](#).

**Table 25. Flash write operations**

Operation	Select bit	Address and data	Start bit
Word program (32-bit)	WPG	FARL/FARH FDR0L/FDR0H	WMS
Double word program (64-bit)	DWPG	FARL/FARH FDR0L/FDR0H FDR1L/FDR1H	WMS
Sector erase	SER	FCR1L/FCR1H	WMS
Set protection	SPR	FDR0L/FDR0H	WMS
Program/erase suspend	SUSP	None	None

[Figure 6](#) shows the complete flow needed for a write operation.

**Figure 6. Write operation control flow**

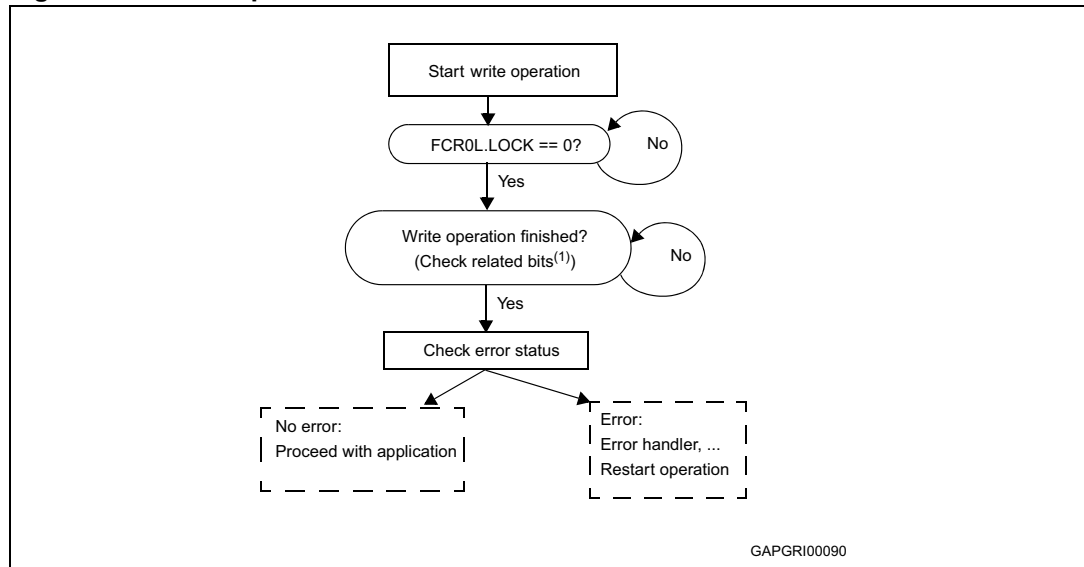

1. The following bits must be checked:
  - Corresponding BSYx bit in FCR0L register
  - WMS bit in FCR0H register
  - Related command bit in FCR0H register"

## 6 Bootstrap loader

The ST10F272M implements boot capabilities in order to:

- Support bootstrap via UART or bootstrap via CAN for the standard bootstrap
- Support a selective bootstrap loader, to manage the bootstrap sequence in a different way

### 6.1 Selection among user-code, standard or selective bootstrap

The boot modes are triggered with a special combination set on `port0I[5...4]`. Those signals, as other configuration signals, are latched on the rising edge of `RSTIN` pin.

- Decoding of reset configuration (P0L.5 = 1, P0L.4 = 1) selects the normal mode (also called User mode) and selects the user Flash to be mapped from address 00'0000h.
- Decoding of reset configuration (P0L.5 = 1, P0L.4 = 0) selects ST10 standard bootstrap mode (test-Flash is active and overlaps user Flash for code fetches from address 00'0000h; user Flash is active and available for read accesses).
- Decoding of reset configuration (P0L.5 = 0, P0L.4 = 1) activates new verifications to select which bootstrap software to execute:
  - if the user mode signature in the user Flash is programmed correctly, then a software reset sequence is selected and the user code is executed;
  - if the User mode signature is not programmed correctly in the user Flash, then the user key location is read again. Its value determines which communication channel will be enabled for bootstrapping.

**Table 26. ST10F272M boot mode selection**

P0.5	P0.4	ST10 decoding
1	1	User mode: User Flash mapped at 00'0000h
1	0	Standard bootstrap loader: User Flash mapped from 00'0000h, code fetches redirected to test-Flash at 00'0000h
0	1	Selective boot mode: User Flash mapped from 00'0000h, code fetches redirected to test-Flash at 00'0000h (different sequence execution compared to standard bootstrap loader)
0	0	Reserved

### 6.2 Standard bootstrap loader

After entering the standard BSL mode and the respective initialization, the ST10F272M scans the `RxD0` line and the `CAN1_RxD` line to receive either a valid dominant bit from the CAN interface or a start condition from the UART line.

**Start condition on UART RxD:** ST10F272M starts standard bootstrap loader. This bootstrap loader is identical to that of other ST10 devices (example: ST10F269, ST10F168).

**Valid dominant bit on CAN1 RxD:** ST10F272M start bootstrapping via CAN1.

**Caution:** As both `UART_RxD` and `CAN1_RxD` lines are polled to detect a start of communication, ensure a stable level on the unused channel by adding a pull-up resistor.

## 6.3 Alternate and selective boot mode (ABM and SBM)

### 6.3.1 Activation of the ABM and SBM

Alternate boot is activated with the combination '01' on Port0L[5..4] at the rising edge of  $\overline{\text{RSTIN}}$ .

### 6.3.2 User mode signature integrity check

The behavior of the selective boot mode is based on the computing of a signature between the content of two memory locations and a comparison with a reference signature. This requires that users who use selective boot have reserved and programmed the Flash memory locations.

### 6.3.3 Selective boot mode

When the user signature is not correct, instead of executing the standard bootstrap loader (triggered by P0L.4 low at reset), additional check is made.

Depending on the value at the user key location, the following behavior occurs:

- A jump is performed to the standard bootstrap loader
- Only UART is enabled for bootstrapping
- Only CAN1 is enabled for bootstrapping
- The device enters an infinite loop

## 7 Central processing unit (CPU)

The CPU includes a 4-stage instruction pipeline, a 16-bit arithmetic and logic unit (ALU) and dedicated SFRs. Additional hardware has been added for a separate multiply and divide unit, a bit-mask generator and a barrel shifter.

Most of the ST10F272M's instructions can be executed in one instruction cycle which requires 50 ns at 40 MHz CPU clock. For example, shift and rotate instructions are processed in one instruction cycle independent of the number of bits to be shifted.

Multiple-cycle instructions have been optimized: branches are carried out in 2 cycles, 16 x 16-bit multiplication in 5 cycles and a 32-/16-bit division in 10 cycles.

The jump cache reduces the execution time of repeatedly performed jumps in a loop, from 2 cycles to 1 cycle.

The CPU uses a bank of 16 word registers to run the current context. This bank of general purpose registers (GPR) is physically stored within the on-chip internal RAM (IRAM) area. A context pointer (CP) register determines the base address of the active register bank to be accessed by the CPU.

The number of register banks is only restricted by the available internal RAM space. For easy parameter passing, a register bank may overlap others.

A system stack of up to 2048 bytes is provided as a storage for temporary data. The system stack is allocated in the on-chip RAM area, and it is accessed by the CPU via the stack pointer (SP) register.

Two separate SFRs, STKOV and STKUN, are implicitly compared against the stack pointer value upon each stack access for the detection of a stack overflow or underflow.

**Figure 7. CPU block diagram (MAC unit not included)**

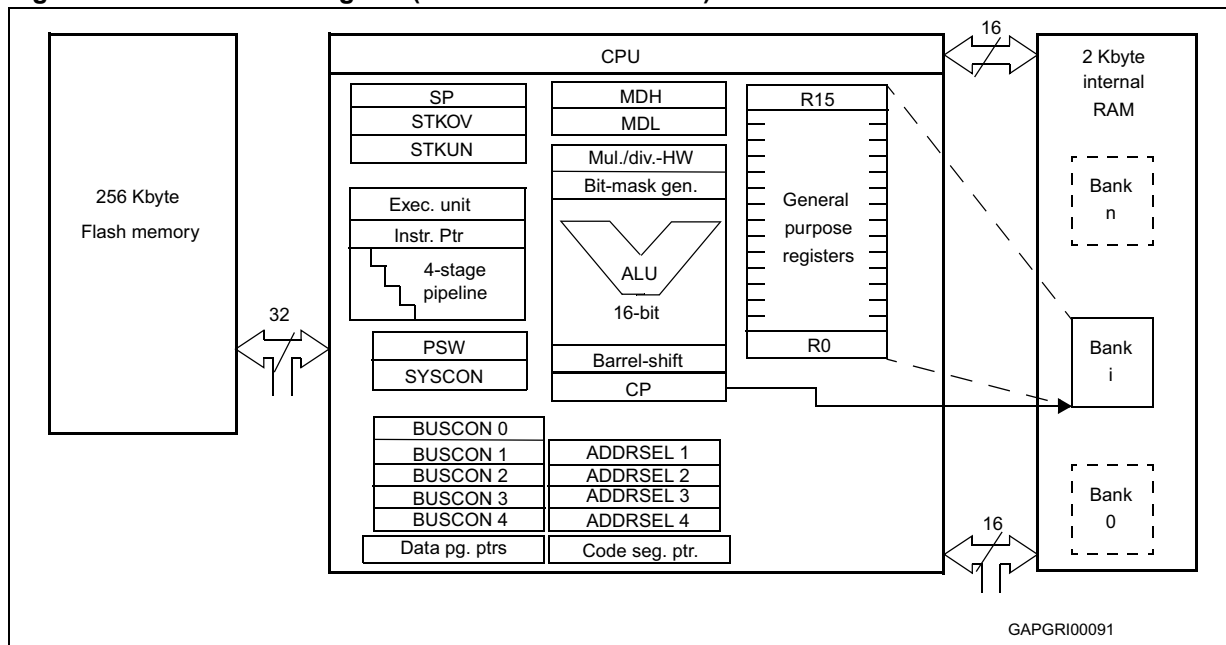

### 7.1 Multiplier-accumulator unit (MAC)

The MAC co-processor is a specialized co-processor added to the ST10 CPU core in order to improve the performances of the ST10 family in signal processing algorithms.

The standard ST10 CPU has been modified to include new addressing capabilities which enable the CPU to supply the new co-processor with up to 2 operands per instruction cycle.

This new co-processor (so-called MAC) contains a fast multiply-accumulate unit and a repeat unit.

The co-processor instructions extend the ST10 CPU instruction set with multiply, multiply-accumulate, 32-bit signed arithmetic operations.

**Figure 8. MAC unit architecture**

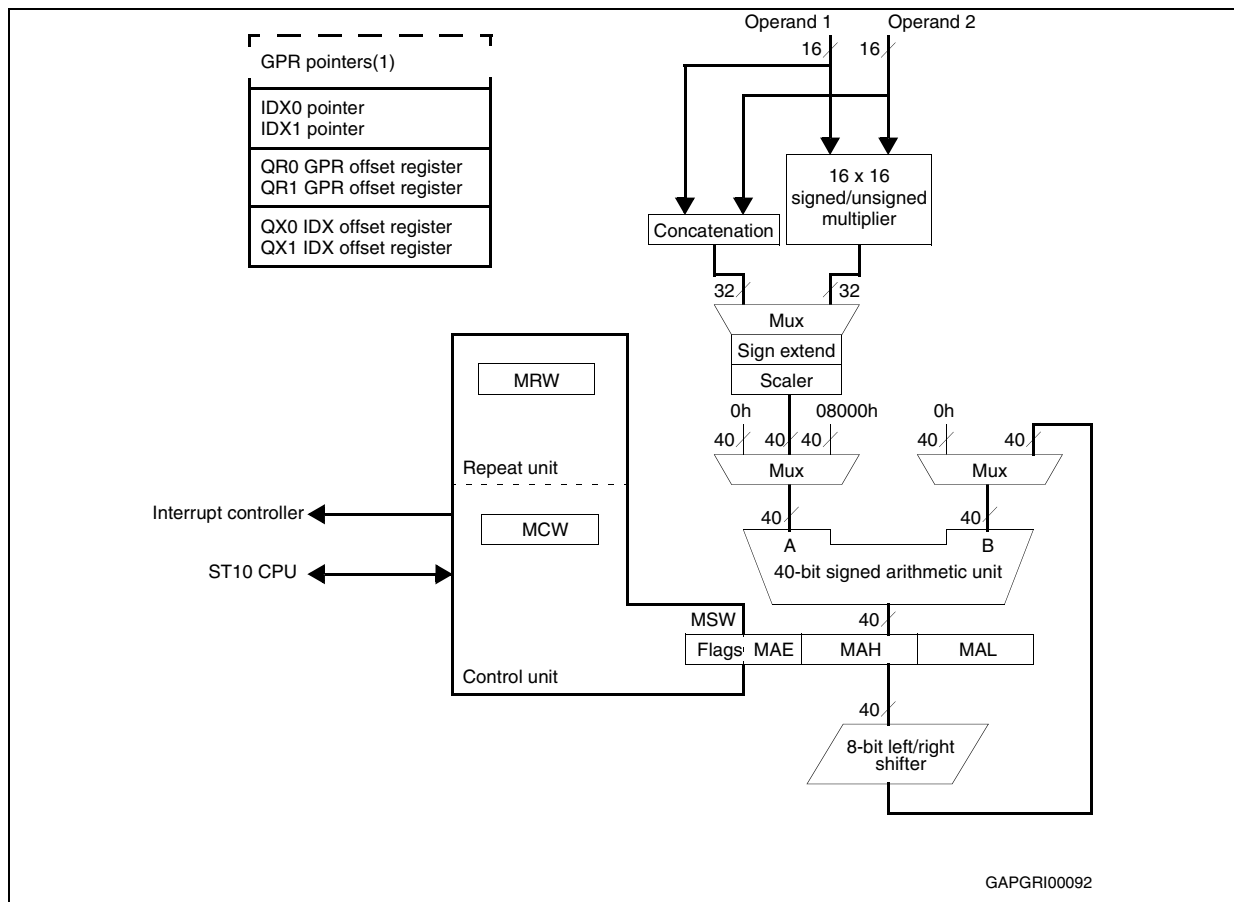

1. Shared with standard ALU

## 7.2 Instruction set summary

[Table 27](#) lists the instructions of the ST10F272M. The detailed description of each instruction can be found in the *ST10 family programming manual*.

**Table 27. Standard instruction set summary**

Mnemonic	Description	Bytes
ADD(B)	Add word (byte) operands	2/4
ADDC(B)	Add word (byte) operands with carry	2/4
SUB(B)	Subtract word (byte) operands	2/4
SUBC(B)	Subtract word (byte) operands with carry	2/4
MUL(U)	(Un)signed multiply direct GPR by direct GPR (16-/16-bit)	2
DIV(U)	(Un)signed divide register MDL by direct GPR (16-/16-bit)	2
DIVL(U)	(Un)signed long divide reg. MD by direct GPR (32-/16-bit)	2
CPL(B)	Complement direct word (byte) GPR	2
NEG(B)	Negate direct word (byte) GPR	2
AND(B)	Bitwise AND, (word/byte operands)	2/4
OR(B)	Bitwise OR, (word/byte operands)	2/4
XOR(B)	Bitwise XOR, (word/byte operands)	2/4
BCLR	Clear direct bit	2
BSET	Set direct bit	2
BMOV(N)	Move (negated) direct bit to direct bit	4
BAND, BOR, BXOR	AND/OR/XOR direct bit with direct bit	4
BCMP	Compare direct bit to direct bit	4
BFLDH/L	Bitwise modify masked high/low byte of bit-addressable direct word memory with immediate data	4
CMP(B)	Compare word (byte) operands	2/4
CMPD1/2	Compare word data to GPR and decrement GPR by 1/2	2/4
CMPI1/2	Compare word data to GPR and increment GPR by 1/2	2/4
PRIOR	Determine number of shift cycles to normalize direct word GPR and store result in direct word GPR	2
SHL/SHR	Shift left/right direct word GPR	2
ROL/ROR	Rotate left/right direct word GPR	2
ASHR	Arithmetic (sign bit) shift right direct word GPR	2
MOV(B)	Move word (byte) data	2/4
MOVBS	Move byte operand to word operand with sign extension	2/4
MOVZ	Move byte operand to word operand with zero extension	2/4
JMPA, JMPI, JMPR	Jump absolute/indirect/relative if condition is met	4
JMPS	Jump absolute to a code segment	4

Table 27. Standard instruction set summary (continued)

Mnemonic	Description	Bytes
J(N)B	Jump relative if direct bit is (not) set	4
JBC	Jump relative and clear bit if direct bit is set	4
JNBS	Jump relative and set bit if direct bit is not set	4
CALLA, CALLI, CALLR	Call absolute/indirect/relative subroutine if condition is met	4
CALLS	Call absolute subroutine in any code segment	4
PCALL	Push direct word register onto system stack and call absolute subroutine	4
TRAP	Call interrupt service routine via immediate trap number	2
PUSH, POP	Push/pop direct word register onto/from system stack	2
SCXT	Push direct word register onto system stack and update register with word operand	4
RET	Return from intra-segment subroutine	2
RETS	Return from inter-segment subroutine	2
RETP	Return from intra-segment subroutine and pop direct word register from system stack	2
RETI	Return from interrupt service subroutine	2
SRST	Software reset	4
IDLE	Enter idle mode	4
PWRDN	Enter power-down mode (supposes $\overline{\text{NMI}}$ -pin being low)	4
SRWDT	Service watchdog timer	4
DISWDT	Disable watchdog timer	4
EINIT	Signify end-of-initialization on RSTOUT-pin	4
ATOMIC	Begin ATOMIC sequence	2
EXTR	Begin EXTended register sequence	2
EXTP(R)	Begin EXTended page (and register) sequence	2/4
EXTS(R)	Begin EXTended segment (and register) sequence	2/4
NOP	Null operation	2



### 7.3 MAC co-processor specific instructions

*Table 28* lists the MAC instructions of the ST10F272M. The detailed description of each instruction can be found in the *ST10 family programming manual*. Note that all MAC instructions are encoded on 4 bytes.

**Table 28. MAC instruction set summary**

Mnemonic	Description
CoABS	Absolute value of the accumulator
CoADD(2)	Addition
CoASHR(rnd)	Accumulator arithmetic shift right and optional round
CoCMP	Compare accumulator with operands
CoLOAD(-,2)	Load accumulator with operands
CoMAC(R,u,s,-,rnd)	(Un)signed/(un)signed multiply-accumulate and optional round
CoMACM(R)(u,s,-,rnd)	(Un)signed/(un)signed multiply-accumulate with parallel data move and optional round
CoMAX / CoMIN	Maximum/minimum of operands and accumulator
CoMOV	Memory to memory move
CoMUL(u,s,-,rnd)	(Un)signed/(un)signed multiply and optional round
CoNEG(rnd)	Negate accumulator and optional round
CoNOP	No operation
CoRND	Round accumulator
CoSHL / CoSHR	Accumulator logical shift left/right
CoSTORE	Store a MAC unit register
CoSUB(2,R)	Subtraction

## 8 External bus controller

All of the external memory accesses are performed by the on-chip external bus controller.

The EBC can be programmed to single chip mode when no external memory is required, or to one of four different external memory access modes:

- 16-/18-/20-/24-bit addresses and 16-bit data, demultiplexed
- 16-/18-/20-/24-bit addresses and 16-bit data, multiplexed
- 16-/18-/20-/24-bit addresses and 8-bit data, multiplexed
- 16-/18-/20-/24-bit addresses and 8-bit data, demultiplexed

In demultiplexed bus modes addresses are output on PORT1 and data is input/output on PORT0 or P0L, respectively. In the multiplexed bus modes both addresses and data use PORT0 for input/output.

Timing characteristics of the external bus interface (memory cycle time, memory tri-state time, length of ALE and read/write delay) are programmable giving the choice of a wide range of memories and external peripherals.

Up to four independent address windows may be defined (using register pairs ADDRSELx/BUSCONx) to access different resources and bus characteristics.

These address windows are arranged hierarchically where BUSCON4 overrides BUSCON3 and BUSCON2 overrides BUSCON1.

All accesses to locations not covered by these four address windows are controlled by BUSCON0. Up to five external  $\overline{CS}$  signals (four windows plus default) can be generated in order to save external glue logic. Access to very slow memories is supported by a 'ready' function.

A  $\overline{HOLD}/\overline{HLDA}$  protocol is available for bus arbitration which shares external resources with other bus masters.

The bus arbitration is enabled by setting bit HLDEN in register PSW. After setting HLDEN once, pins P6.7...P6.5 ( $\overline{BREQ}$ ,  $\overline{HLDA}$ ,  $\overline{HOLD}$ ) are automatically controlled by the EBC. In master mode (default after reset) the  $\overline{HLDA}$  pin is an output. By setting bit DP6.7 to '1' the slave mode is selected where pin  $\overline{HLDA}$  is switched to input. This directly connects the slave controller to another master controller without glue logic.

For applications which require less external memory space, the address space can be restricted to 1 Mbyte, 256 Kbytes or to 64 Kbytes. Port 4 outputs all eight address lines if an address space of 16 Mbytes is used, otherwise four, two or no address lines.

Chip select timing can be made programmable. By default (after reset), the  $\overline{CSx}$  lines change half a CPU clock cycle after the rising edge of ALE. With the CSCFG bit set in the SYSCON register the  $\overline{CSx}$  lines change with the rising edge of ALE.

The active level of the  $\overline{READY}$  pin can be set by bit RDYPOL in the BUSCONx registers. When the READY function is enabled for a specific address window, each bus cycle within the window must be terminated with the active level defined by bit RDYPOL in the associated BUSCON register.

## 9 Interrupt system

The interrupt response time for internal program execution is from 125 ns to 300 ns at 40 MHz CPU clock.

The ST10F272M architecture supports several mechanisms for fast and flexible response to service requests that can be generated from various sources (internal or external) to the microcontroller. Any of these interrupt requests can be serviced by the interrupt controller or by the peripheral event controller (PEC).

In contrast to a standard interrupt service where the current program execution is suspended and a branch to the interrupt vector table is performed, just one cycle is 'stolen' from the current CPU activity to perform a PEC service. A PEC service implies a single byte or word data transfer between any two memory locations with an additional increment of either the PEC source or destination pointer. An individual PEC transfer counter is implicitly decremented for each PEC service except when performing in the continuous transfer mode. When this counter reaches zero, a standard interrupt is performed to the corresponding source related vector location. PEC services are very well suited to perform the transmission or the reception of blocks of data. The ST10F272M has eight PEC channels, each of them offers such fast interrupt-driven data transfer capabilities.

An interrupt control register which contains an interrupt request flag, an interrupt enable flag and an interrupt priority bit-field is dedicated to each existing interrupt source. Thanks to its related register, each source can be programmed to one of sixteen interrupt priority levels. Once starting to be processed by the CPU, an interrupt service can only be interrupted by a higher prioritized service request. For the standard interrupt processing, each of the possible interrupt sources has a dedicated vector location.

Software interrupts are supported by means of the 'TRAP' instruction in combination with an individual trap (interrupt) number.

Fast external interrupt inputs are provided to service external interrupts with high precision requirements. These fast interrupt inputs feature programmable edge detection (rising edge, falling edge or both edges).

Fast external interrupts may also have interrupt sources selected from other peripherals; for example, the CANx controller receives signals (CANx\_RxD) and I<sup>2</sup>C serial clock signal can be used to interrupt the system.

[Table 29](#) shows all the available ST10F272M interrupt sources and the corresponding hardware-related interrupt flags, vectors, vector locations and trap (interrupt) numbers.

**Table 29. Interrupt sources**

Source of interrupt or PEC service request	Request flag	Enable flag	Interrupt vector	Vector location	Trap number
CAPCOM register 0	CC0IR	CC0IE	CC0INT	00'0040h	10h
CAPCOM register 1	CC1IR	CC1IE	CC1INT	00'0044h	11h
CAPCOM register 2	CC2IR	CC2IE	CC2INT	00'0048h	12h
CAPCOM register 3	CC3IR	CC3IE	CC3INT	00'004Ch	13h
CAPCOM register 4	CC4IR	CC4IE	CC4INT	00'0050h	14h
CAPCOM register 5	CC5IR	CC5IE	CC5INT	00'0054h	15h

**Table 29. Interrupt sources (continued)**

Source of interrupt or PEC service request	Request flag	Enable flag	Interrupt vector	Vector location	Trap number
CAPCOM register 6	CC6IR	CC6IE	CC6INT	00'0058h	16h
CAPCOM register 7	CC7IR	CC7IE	CC7INT	00'005Ch	17h
CAPCOM register 8	CC8IR	CC8IE	CC8INT	00'0060h	18h
CAPCOM register 9	CC9IR	CC9IE	CC9INT	00'0064h	19h
CAPCOM register 10	CC10IR	CC10IE	CC10INT	00'0068h	1Ah
CAPCOM register 11	CC11IR	CC11IE	CC11INT	00'006Ch	1Bh
CAPCOM register 12	CC12IR	CC12IE	CC12INT	00'0070h	1Ch
CAPCOM register 13	CC13IR	CC13IE	CC13INT	00'0074h	1Dh
CAPCOM register 14	CC14IR	CC14IE	CC14INT	00'0078h	1Eh
CAPCOM register 15	CC15IR	CC15IE	CC15INT	00'007Ch	1Fh
CAPCOM register 16	CC16IR	CC16IE	CC16INT	00'00C0h	30h
CAPCOM register 17	CC17IR	CC17IE	CC17INT	00'00C4h	31h
CAPCOM register 18	CC18IR	CC18IE	CC18INT	00'00C8h	32h
CAPCOM register 19	CC19IR	CC19IE	CC19INT	00'00CCh	33h
CAPCOM register 20	CC20IR	CC20IE	CC20INT	00'00D0h	34h
CAPCOM register 21	CC21IR	CC21IE	CC21INT	00'00D4h	35h
CAPCOM register 22	CC22IR	CC22IE	CC22INT	00'00D8h	36h
CAPCOM register 23	CC23IR	CC23IE	CC23INT	00'00DCh	37h
CAPCOM register 24	CC24IR	CC24IE	CC24INT	00'00E0h	38h
CAPCOM register 25	CC25IR	CC25IE	CC25INT	00'00E4h	39h
CAPCOM register 26	CC26IR	CC26IE	CC26INT	00'00E8h	3Ah
CAPCOM register 27	CC27IR	CC27IE	CC27INT	00'00ECh	3Bh
CAPCOM register 28	CC28IR	CC28IE	CC28INT	00'00F0h	3Ch
CAPCOM register 29	CC29IR	CC29IE	CC29INT	00'0110h	44h
CAPCOM register 30	CC30IR	CC30IE	CC30INT	00'0114h	45h
CAPCOM register 31	CC31IR	CC31IE	CC31INT	00'0118h	46h
CAPCOM timer 0	T0IR	T0IE	T0INT	00'0080h	20h
CAPCOM timer 1	T1IR	T1IE	T1INT	00'0084h	21h
CAPCOM timer 7	T7IR	T7IE	T7INT	00'00F4h	3Dh
CAPCOM timer 8	T8IR	T8IE	T8INT	00'00F8h	3Eh
GPT1 timer 2	T2IR	T2IE	T2INT	00'0088h	22h
GPT1 timer 3	T3IR	T3IE	T3INT	00'008Ch	23h
GPT1 timer 4	T4IR	T4IE	T4INT	00'0090h	24h
GPT2 timer 5	T5IR	T5IE	T5INT	00'0094h	25h

**Table 29. Interrupt sources (continued)**

Source of interrupt or PEC service request	Request flag	Enable flag	Interrupt vector	Vector location	Trap number
GPT2 timer 6	T6IR	T6IE	T6INT	00'0098h	26h
GPT2 CAPREL register	CRIR	CRIE	CRINT	00'009Ch	27h
A/D conversion complete	ADCIR	ADCIE	ADCINT	00'00A0h	28h
A/D overrun error	ADEIR	ADEIE	ADEINT	00'00A4h	29h
ASC0 transmit	S0TIR	S0TIE	S0TINT	00'00A8h	2Ah
ASC0 transmit buffer	S0TBIR	S0TBIE	S0TBINT	00'011Ch	47h
ASC0 receive	S0RIR	S0RIE	S0RINT	00'00ACh	2Bh
ASC0 error	S0EIR	S0EIE	S0EINT	00'00B0h	2Ch
SSC transmit	SCTIR	SCTIE	SCTINT	00'00B4h	2Dh
SSC receive	SCRIR	SCRIE	SCRINT	00'00B8h	2Eh
SSC error	SCEIR	SCEIE	SCEINT	00'00BCh	2Fh
PWM channel 0...3	PWMIR	PWMIE	PWMINT	00'00FCh	3Fh
See <a href="#">Section 9.1</a>	XP0IR	XP0IE	XP0INT	00'0100h	40h
See <a href="#">Section 9.1</a>	XP1IR	XP1IE	XP1INT	00'0104h	41h
See <a href="#">Section 9.1</a>	XP2IR	XP2IE	XP2INT	00'0108h	42h
See <a href="#">Section 9.1</a>	XP3IR	XP3IE	XP3INT	00'010Ch	43h

Hardware traps are exceptions or error conditions that arise during run-time. They cause immediate non-maskable system reaction similar to a standard interrupt service (branching to a dedicated vector table location).

The occurrence of a hardware trap is additionally signified by an individual bit in the trap flag register (TFR). A hardware trap will interrupt any other program execution except when another higher prioritized trap service is in progress. Hardware trap services cannot not be interrupted by a standard interrupt or by PEC interrupts.

## 9.1 X-peripheral interrupt

The limited number of X-bus interrupt lines of the present ST10 architecture, imposes some constraints on the implementation of the new functionality. In particular, the additional X-peripherals SSC1, ASC1, I<sup>2</sup>C, PWM1 and RTC need some resources to implement interrupt and PEC transfer capabilities. For this reason, a multiplexed structure for the interrupt management is proposed. In [Figure 9](#), the principle is explained through a simple diagram, which shows the basic structure replicated for each of the four X-interrupt available vectors (XP0INT, XP1INT, XP2INT and XP3INT).

It is based on a set of 16-bit registers XIRxSEL (x = 0,1,2,3), divided in two portions each:

- Byte high XIRxSEL[15:8] Interrupt enable bits
- Byte low XIRxSEL[7:0] Interrupt flag bits

When different sources submit an interrupt request, the enable bits (byte high of XIRxSEL register) define a mask which controls which sources will be associated with the unique available vector. If more than one source is enabled to issue the request, the service routine will have to take care to identify the real event to be serviced. This can easily be done by checking the flag bits (byte low of XIRxSEL register). Note that the flag bits can also provide information about events which are not currently serviced by the interrupt controller (since they are masked through the enable bits), allowing an effective software management even if the related interrupt request cannot be served: A periodic polling of the flag bits may be implemented inside the user application.

**Figure 9. X-interrupt basic structure**

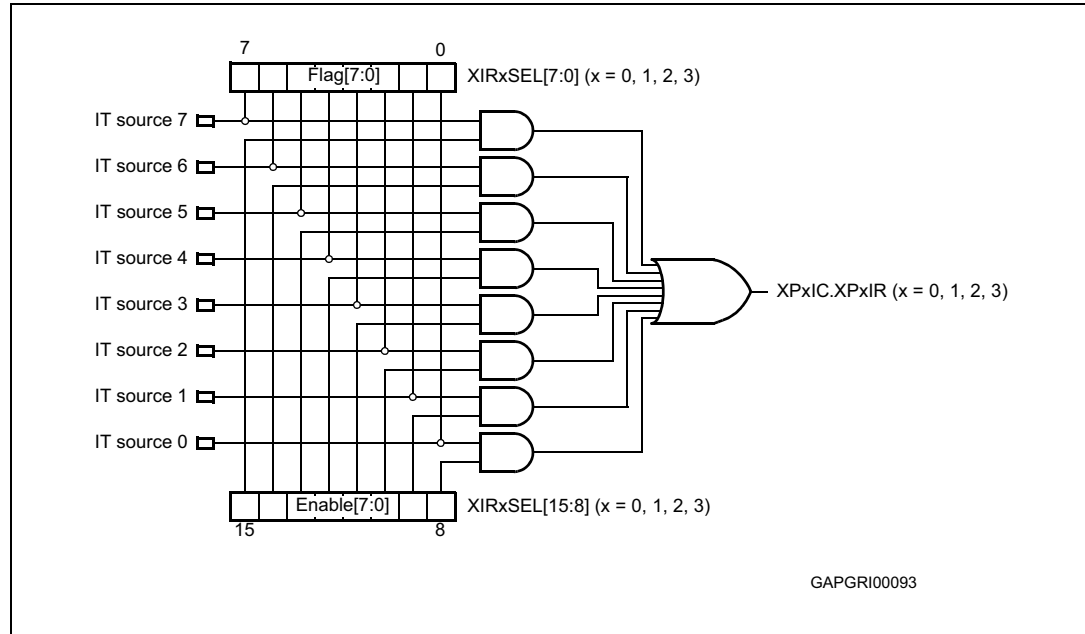

Table 30 summarizes the mapping of the different interrupt sources which shares the four X-interrupt vectors.

**Table 30. X-interrupt detailed mapping**

Interrupt source	XP0INT	XP1INT	XP2INT	XP3INT
CAN1 interrupt	x			x
CAN2 interrupt		x		x
I <sup>2</sup> C receive	x	x	x	
I <sup>2</sup> C transmit	x	x	x	
I <sup>2</sup> C error				x
SSC1 receive	x	x	x	
SSC1 transmit	x	x	x	
SSC1 error				x
ASC1 receive	x	x	x	
ASC1 transmit	x	x	x	

**Table 30. X-interrupt detailed mapping (continued)**

Interrupt source	XP0INT	XP1INT	XP2INT	XP3INT
ASC1 transmit buffer	x	x	x	
ASC1 error				x
PLL unlock/OWD				x
PWM1 channel 3...0			x	x

## 9.2 Exception and error traps list

[Table 31](#) shows all of the possible exceptions or error conditions that can arise during run-time.

**Table 31. Trap priorities**

Exception condition	Trap flag	Trap vector	Vector location	Trap number	Trap priority <sup>(1)</sup>
Reset functions:					
Hardware reset		Reset	00'0000h	00h	III
Software reset		Reset	00'0000h	00h	III
Watchdog timer overflow		Reset	00'0000h	00h	III
Class A hardware traps:					
Non-maskable interrupt	NMI	NMITRAP	00'0008h	02h	II
Stack overflow	STKOF	STOTRAP	00'0010h	04h	II
Stack underflow	STKUF	STUTRAP	00'0018h	06h	II
Class B hardware traps:					
Undefined opcode	UNDOPC	BTRAP	00'0028h	0Ah	I
MAC interruption	MACTRP	BTRAP	00'0028h	0Ah	I
Protected instruction fault	PRTFLT	BTRAP	00'0028h	0Ah	I
Illegal word operand access	ILLOPA	BTRAP	00'0028h	0Ah	I
Illegal instruction access	ILLINA	BTRAP	00'0028h	0Ah	I
Illegal external bus access	ILLBUS	BTRAP	00'0028h	0Ah	I
Reserved			[002Ch - 003Ch]	[0Bh - 0Fh]	
Software traps			Any	Any	Current
TRAP instruction			0000h – 01FCh in steps of 4h	[00h - 7Fh]	CPU priority

- All the class B traps have the same trap number (and vector) and the same lower priority compared to the class A traps and to the resets.
  - Each class A trap has a dedicated trap number (and vector). They are prioritized in the second priority level.
  - The resets have the highest priority level and the same trap number.
  - The PSW.ILVL CPU priority is forced to the highest level (15) when these exceptions are serviced.

## 10 Capture/compare (CAPCOM) units

The ST10F272M has two 16-channel CAPCOM units which support generation and control of timing sequences on up to 32 channels with a maximum resolution of 125 ns at 40 MHz CPU clock.

The CAPCOM units are typically used to handle high speed I/O tasks such as pulse and waveform generation, pulse width modulation (PWM), digital to analog (D/A) conversion, software timing, or time recording relative to external events.

Four 16-bit timers (T0/T1, T7/T8) with reload registers provide two independent time bases for the capture/compare register array.

The input clock for the timers is programmable to several prescaled values of the internal system clock, or may be derived from an overflow/underflow of timer T6 in module GPT2.

This provides a wide range of variation for the timer period and resolution, and allows precise adjustments to application specific requirements. In addition, external count inputs for CAPCOM timers T0 and T7 allow event scheduling for the capture/compare registers relative to external events.

Each of the two capture/compare register arrays contain 16 dual purpose capture/compare registers, each of which may be individually allocated to either CAPCOM timer T0 or T1 (T7 or T8, respectively), and programmed for capture or compare functions. Each of the 32 registers has one associated port pin which serves as an input pin for triggering the capture function, or as an output pin to indicate the occurrence of a compare event.

When a capture/compare register has been selected for capture mode, the current contents of the allocated timer will be latched (captured) into the capture/compare register in response to an external event at the port pin which is associated with this register. In addition, a specific interrupt request for this capture/compare register is generated.

Either a positive, a negative, or both a positive and a negative external signal transition at the pin can be selected as the triggering event. The contents of all registers which have been selected for one of the five compare modes are continuously compared with the contents of the allocated timers.

When a match occurs between the timer value and the value in a capture/compare register, specific actions will be taken based on the selected compare mode.

The input frequencies  $f_{Tx}$ , for the timer input selector Tx, are determined as a function of the CPU clocks. The timer input frequencies, resolution and periods which result from the selected prescaler option in Tx1 when using a 40 MHz CPU clock are listed in [Table 33](#).

The numbers for the timer periods are based on a reload value of 0000h. Note that some numbers may be rounded off to three significant figures.



Table 32. Compare modes

Compare modes	Function
Mode 0	Interrupt-only compare mode; several compare interrupts per timer period are possible
Mode 1	Pin toggles on each compare match; several compare events per timer period are possible
Mode 2	Interrupt-only compare mode; only one compare interrupt per timer period is generated
Mode 3	Pin set '1' on match; pin reset '0' on compare time overflow; only one compare event per timer period is generated
Double register mode	Two registers operate on one pin; pin toggles on each compare match; several compare events per timer period are possible.

Table 33. CAPCOM timer input frequencies, resolutions and periods at 40 MHz

f <sub>CPU</sub> = 40 MHz	Timer input selection Tx1							
	000b	001b	010b	011b	100b	101b	110b	111b
Prescaler for f <sub>CPU</sub>	8	16	32	64	128	256	512	1024
Input frequency	5 MHz	2.5 MHz	1.25 MHz	625 kHz	312.5 kHz	156.25 kHz	78.125 kHz	39.1 kHz
Resolution	200 ns	400 ns	0.8 μs	1.6 μs	3.2 μs	6.4 μs	12.8 μs	25.6 μs
Period	13.1 ms	26.2 ms	52.4 ms	104.8 ms	209.7 ms	419.4 ms	838.9 ms	1.678 s

## 11 General purpose timer unit

The GPT unit is a flexible multifunctional timer/counter structure which is used for time related tasks such as event timing and counting, pulse width and duty cycle measurements, pulse generation, or pulse multiplication. The GPT unit contains five 16-bit timers organized into two separate modules GPT1 and GPT2. Each timer in each module may operate independently in several different modes, or may be concatenated with another timer of the same module.

### 11.1 GPT1

Each of the three timers T2, T3, T4 of the GPT1 module can be configured individually for one of four basic modes of operation: timer, gated timer, counter mode and incremental interface mode.

In timer mode, the input clock for a timer is derived from the CPU clock, divided by a programmable prescaler.

In counter mode, the timer is clocked in reference to external events.

Pulse width or duty cycle measurement is supported in gated timer mode where the operation of a timer is controlled by the 'gate' level on an external input pin. For these purposes, each timer has one associated port pin (TxIN) which serves as gate or clock input.

[Table 34](#) lists the timer input frequencies, resolution and periods for each prescaler option at 40 MHz CPU clock.

In incremental interface mode, the GPT1 timers (T2, T3, T4) can be directly connected to the incremental position sensor signals A and B by their respective inputs TxIN and TxEUD.

Direction and count signals are internally derived from these two input signals so that the contents of the respective timer Tx corresponds to the sensor position. The third position sensor signal TOP0 can be connected to an interrupt input.

Timer T3 has output toggle latches (TxOTL) which changes state on each timer over flow / underflow. The state of this latch may be output on port pins (TxOUT) for time out monitoring of external hardware components, or may be used internally to clock timers T2 and T4 for high resolution of long duration measurements.

In addition to their basic operating modes, timers T2 and T4 may be configured as reload or capture registers for timer T3.

Table 34. GPT1 timer input frequencies, resolutions and periods at 40 MHz

f <sub>CPU</sub> = 40 MHz	Timer input selection T2I / T3I / T4I							
	000b	001b	010b	011b	100b	101b	110b	111b
Prescaler factor	8	16	32	64	128	256	512	1024
Input frequency	5 MHz	2.5 MHz	1.25 MHz	625 kHz	312.5 kHz	156.25 kHz	78.125 kHz	39.1 kHz
Resolution	200 ns	400 ns	0.8 μs	1.6 μs	3.2 μs	6.4 μs	12.8 μs	25.6 μs
Period maximum	13.1 ms	26.2 ms	52.4 ms	104.8 ms	209.7 ms	419.4 ms	838.9 ms	1.678 s

Figure 10. Block diagram of GPT1

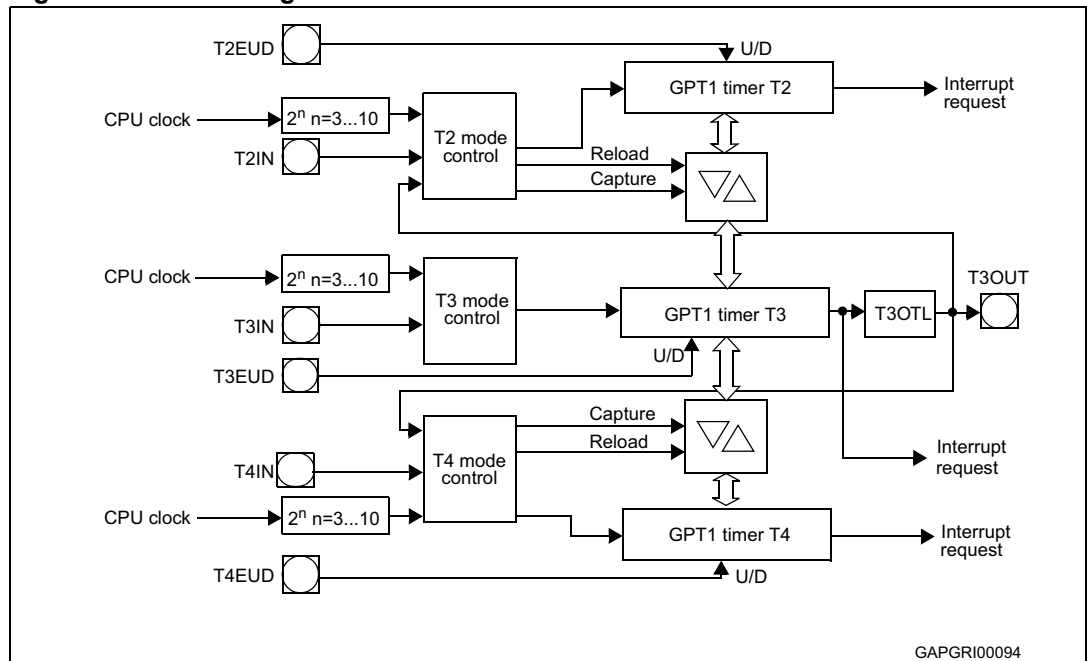

## 11.2 GPT2

The GPT2 module provides precise event control and time measurement. It includes two timers (T5, T6) and a capture/reload register (CAPREL). Both timers can be clocked with an input clock which is derived from the CPU clock via a programmable prescaler or with external signals. The count direction (up/down) for each timer is programmable by software or may additionally be altered dynamically by an external signal on a port pin (TxEUD). Concatenation of the timers is supported via the output toggle latch (T6OTL) of timer T6 which changes its state on each timer overflow/underflow.

The state of this latch may be used to clock timer T5, or it may be output on a port pin (T6OUT). The overflow / underflow of timer T6 can additionally be used to clock the CAPCOM timers T0 or T1, and to cause a reload from the CAPREL register. The CAPREL register may capture the contents of timer T5 based on an external signal transition on the corresponding port pin (CAPIN), and timer T5 may optionally be cleared after the capture procedure. This allows absolute time differences to be measured or pulse multiplication to be performed without software overhead.

The capture trigger (timer T5 to CAPREL) may also be generated upon transitions of GPT1 timer T3 inputs T3IN and/or T3EUD. This is advantageous when T3 operates in Incremental Interface mode.

[Table 35](#) lists the timer input frequencies, resolution and periods for each prescaler option at 40 MHz CPU clock.

**Table 35. GPT2 timer input frequencies, resolutions and periods at 40 MHz**

f <sub>CPU</sub> = 40 MHz	Timer input selection T5I/T6I							
	000b	001b	010b	011b	100b	101b	110b	111b
Prescaler factor	4	8	16	32	64	128	256	512
Input frequency	10 MHz	5 MHz	2.5 MHz	1.25 MHz	625 kHz	312.5 kHz	156.25 kHz	78.125 kHz
Resolution	100 ns	200 ns	400 ns	0.8 μs	1.6 μs	3.2 μs	6.4 μs	12.8 μs
Period maximum	6.55 ms	13.1 ms	26.2 ms	52.4 ms	104.8 ms	209.7 ms	419.4 ms	838.9 ms

Figure 11. Block diagram of GPT2

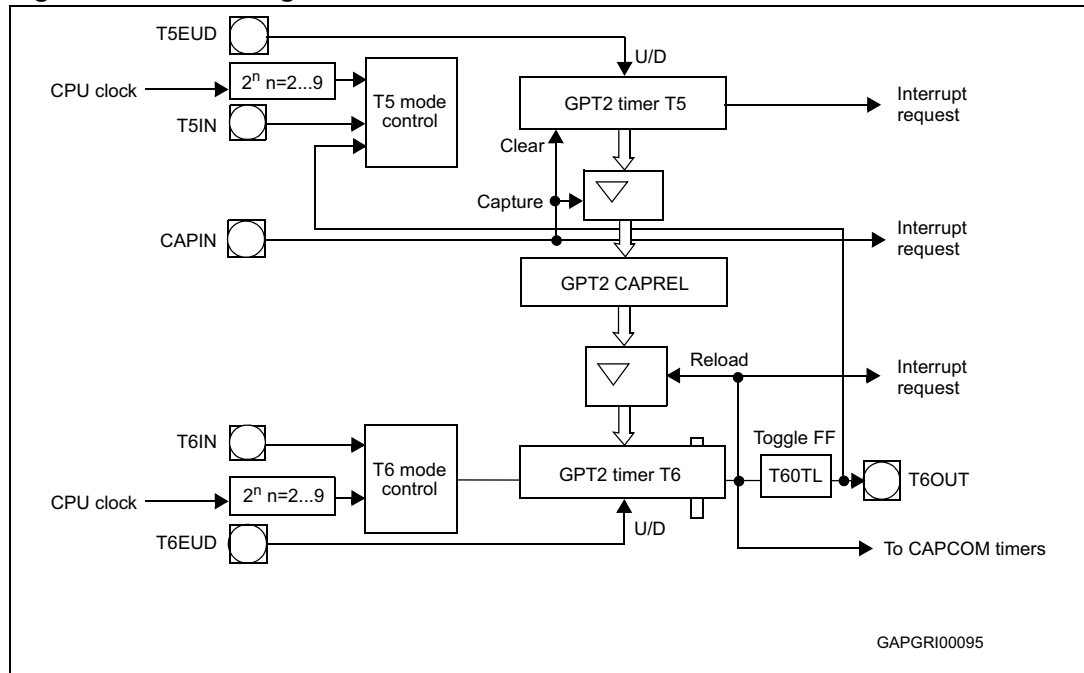

# 12 PWM modules

Two pulse width modulation modules are available on ST10F272M: standard PWM0 and XBUS PWM1. They can generate up to four PWM output signals each, using edge-aligned or center-aligned PWM. In addition, the PWM modules can generate PWM burst signals and single shot outputs. [Table 36](#) shows the PWM frequencies for different resolutions. The level of the output signals is selectable and the PWM modules can generate interrupt requests.

**Figure 12. Block diagram of PWM module**

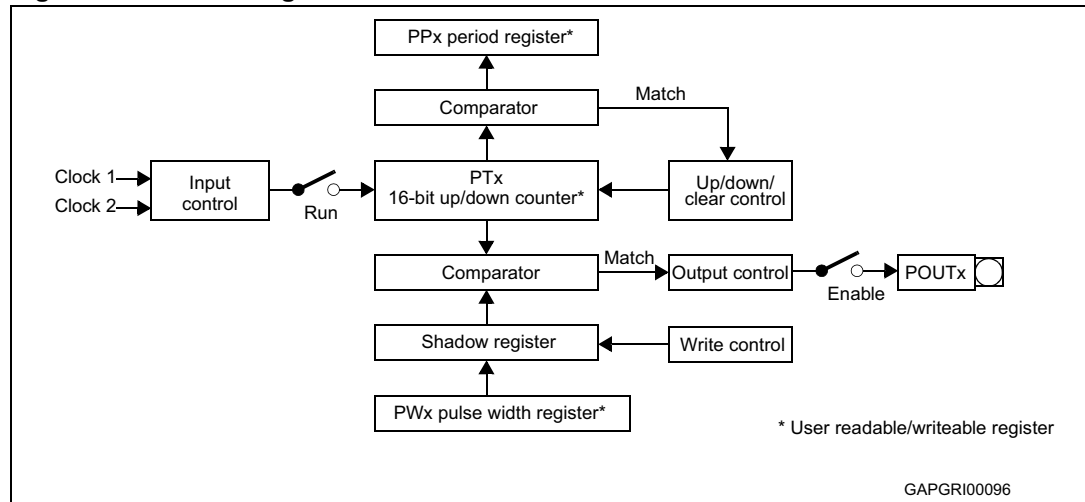

**Table 36. PWM unit frequencies and resolutions at 40 MHz CPU clock**

Mode 0	Resolution	8-bit	10-bit	12-bit	14-bit	16-bit
CPU clock/1	25 ns	156.25 kHz	39.1 kHz	9.77 kHz	2.44 Hz	610 Hz
CPU clock/64	1.6 μs	2.44 kHz	610Hz	152.6 Hz	38.15 Hz	9.54 Hz
Mode 1	Resolution	8-bit	10-bit	12-bit	14-bit	16-bit
CPU clock/1	25 ns	78.12 kHz	19.53 kHz	4.88 kHz	1.22 kHz	305.2 Hz
CPU clock/64	1.6 μs	1.22 kHz	305.17 Hz	76.29 Hz	19.07 Hz	4.77 Hz

## 13 Parallel ports

### 13.1 Introduction

The ST10F272M MCU provides up to 111 I/O lines with programmable features. These capabilities permit this MCU to be adapted to a wide range of applications.

ST10F272M has nine groups of I/O lines gathered as follows:

- Port 0 is a two time 8-bit port named P0L (low as less significant byte) and P0H (high as most significant byte)
- Port 1 is a two time 8-bit port named P1L and P1H
- Port 2 is a 16-bit port
- Port 3 is a 15-bit port (P3.14 line is not implemented)
- Port 4 is an 8-bit port
- Port 5 is a 16-bit port input only
- Port 6, Port 7 and Port 8 are 8-bit ports

These ports may be used as general purpose bidirectional input or output, software controlled with dedicated registers.

For example, the output drivers of six of the ports (2, 3, 4, 6, 7, 8) can be configured (bitwise) for push-pull or open drain operation using ODPx registers.

The input threshold levels are programmable (TTL/CMOS) for all the ports. The logic level of a pin is clocked into the input latch once per state time, regardless whether the port is configured for input or output. The threshold is selected with PICON and XPICON registers control bits.

A write operation to a port pin configured as an input causes the value to be written into the port output latch, while a read operation returns the latched state of the pin itself. A read-modify-write operation reads the value of the pin, modifies it, and writes it back to the output latch.

Writing to a pin configured as an output (DPx.y = '1') causes the output latch and the pin to have the written value, since the output buffer is enabled. Reading this pin returns the value of the output latch. A read-modify-write operation reads the value of the output latch, modifies it, and writes it back to the output latch, thus also modifying the level at the pin.

I/O lines support an alternate function which is detailed in the following description of each port.

### 13.2 I/O's special features

#### 13.2.1 Open drain mode

Some of the I/O ports of ST10F272M support the open drain capability. This programmable feature may be used with an external pull-up resistor, in order to provide an AND wired logical function.

This feature is implemented for ports P2, P3, P4, P6, P7 and P8 (see respective sections), and is controlled through the respective open drain control registers ODPx.

### 13.2.2 Input threshold control

The standard inputs of the ST10F272M determine the status of input signals according to TTL levels. In order to accept and recognize noisy signals, CMOS input thresholds can be selected instead of the standard TTL thresholds for all the pins. These CMOS thresholds are defined above the TTL thresholds and feature a higher hysteresis to prevent the inputs from toggling while the respective input signal level is near the thresholds.

The port input control registers PICON and XPICON are used to select these thresholds for each byte of the indicated ports, this means the 8-bit ports P0L, P0H, P1L, P1H, P4, P7 and P8 are controlled by one bit each while ports P2, P3 and P5 are controlled by two bits each.

All options for individual direction and output mode control are available for each pin, independent of the selected input threshold.

## 13.3 Alternate port functions

Each port line has one associated programmable alternate input or output function.

- Port0 and port1 may be used as address and data lines when accessing external memory. Additionally, port1 provides:
  - Input capture lines
  - 8 additional analog input channels to the A/D converter
- Port 2, port 7 and port 8 are associated with the capture inputs or compare outputs of the CAPCOM units and/or with the outputs of the PWM0 module, of the PWM1 module and of the ASC1.  
Port 2 is also used for fast external interrupt inputs and for timer 7 input.
- Port 3 includes the alternate functions of timers, serial interfaces, the optional bus control signal  $\overline{BHE}$  and the system clock output (CLKOUT).
- Port 4 outputs the additional segment address bit A23...A16 in systems where more than 64 Kbytes of memory are to be access directly. In addition, CAN1, CAN2 and I<sup>2</sup>C lines are provided.
- Port 5 is used as analog input channels of the A/D converter or as timer control signals.
- Port 6 provides optional bus arbitration signals ( $\overline{BREQ}$ ,  $\overline{HLDA}$ ,  $\overline{HOLD}$ ) and chip select signals and the SSC1 lines.

If the alternate output function of a pin is to be used, the direction of this pin must be programmed for output (DPx.y = '1'), except for some signals that are used directly after reset and are configured automatically. Otherwise the pin remains in the high-impedance state and is not effected by the alternate output function. The respective port latch should hold a '1', because its output is ANDed with the alternate output data (except for PWM output signals).

If the alternate input function of a pin is used, the direction of the pin must be programmed for input (DPx.y = '0') if an external device is driving the pin. The input direction is the default after reset. If no external device is connected to the pin, however, the direction for this pin can also be set to output. In this case, the pin reflects the state of the port output latch. Thus, the alternate input function reads the value stored in the port output latch. This can be used for testing purposes to allow a software trigger of an alternate input function by writing to the port output latch.

On most of the port lines, the user software is responsible for setting the proper direction when using an alternate input or output function of a pin.



This is done by setting or clearing the direction control bit DPx.y of the pin before enabling the alternate function.

There are port lines, however, where the direction of the port line is switched automatically.

For instance, in the multiplexed external bus modes of port0, the direction must be switched several times for an instruction fetch in order to output the addresses and to input the data.

Obviously, this cannot be done through instructions. In these cases, the direction of the port line is switched automatically by hardware if the alternate function of such a pin is enabled.

To determine the appropriate level of the port output latches, check how the alternate data output is combined with the respective port latch output.

There is one basic structure for all port lines with only an alternate input function. Port lines with only an alternate output function, however, have different structures due to the way the direction of the pin is switched and depending on whether the pin is accessible by the user software or not in the alternate function mode.

All port lines that are not used for these alternate functions may be used as general purpose I/O lines.

## 14 A/D converter

A 10-bit A/D converter with 16+8 multiplexed input channels and a sample and hold circuit is integrated on-chip. An automatic self-calibration adjusts the A/D converter module to process parameter variations at each reset event. The sample time (for loading the capacitors) and the conversion time is programmable and can be adjusted to the external circuitry.

The Root part number 1 has 16+8 multiplexed input channels on port 5 and port 1. The selection between port 5 and port 1 is made via a bit in an X-bus register. Refer to the user manual for a detailed description.

A different accuracy is guaranteed (total unadjusted error) on port 5 and port 1 analog channels (with higher restrictions when overload conditions occur); in particular, port 5 channels are more accurate than the port 1 channels. Refer to [Section 24: Electrical characteristics](#) for details.

The A/D converter input bandwidth is limited by the achievable accuracy: supposing a maximum error of 0.5 LSB (2 mV) impacting the global TUE (TUE also depends on other causes), in worst case of temperature and process, the maximum frequency for a sine wave analog signal is approximately 7.5 kHz. Of course, to reduce the effect of the input signal variation on the accuracy down to 0.05 LSB, the maximum input frequency of the sine wave must be reduced to 800 Hz.

If static signal is applied during sampling phase, series resistance must not be greater than 20 k $\Omega$  (this taking into account eventual input leakage). It is suggested to not connect any capacitance on analog input pins, in order to reduce the effect of charge partitioning (and consequent voltage drop error) between the external and the internal capacitance: in case an RC filter is necessary the external capacitance must be greater than 10 nF to minimize the accuracy impact.

Overrun error detection/protection is controlled by the ADDAT register. Either an interrupt request is generated when the result of a previous conversion has not been read from the result register at the time the next conversion is complete, or the next conversion is suspended until the previous result has been read. For applications which require less than 16+8 analog input channels, the remaining channel inputs can be used as digital input port pins.

The A/D converter of the Root part number 1 supports different conversion modes:

- **Single channel single conversion:** The analog level of the selected channel is sampled once and converted. The result of the conversion is stored in the ADDAT register.
- **Single channel continuous conversion:** The analog level of the selected channel is repeatedly sampled and converted. The result of the conversion is stored in the ADDAT register.
- **Auto scan single conversion:** The analog level of the selected channels are sampled once and converted. After each conversion the result is stored in the ADDAT register. The data can be transferred to the RAM by interrupt software management or using the powerful peripheral event controller (PEC) data transfer.

- **Auto scan continuous conversion:** The analog level of the selected channels are repeatedly sampled and converted. The result of the conversion is stored in the ADDAT register. The data can be transferred to the RAM by interrupt software management or using the PEC data transfer.
- **Wait for ADDAT read mode:** When using continuous modes, in order to avoid to overwrite the result of the current conversion by the next one, the ADWR bit of ADCON control register must be activated. Then, until the ADDAT register is read, the new result is stored in a temporary buffer and the conversion is on hold.
- **Channel injection mode:** When using continuous modes, a selected channel can be converted in between without changing the current operating mode. The 10-bit data of the conversion are stored in ADRES field of ADDAT2. The current continuous mode remains active after the single conversion is completed.

A full calibration sequence is performed after a reset. This full calibration lasts up to 40630 CPU clock cycles. During this time, the busy flag ADBSY is set to indicate the operation. It compensates the capacitance mismatch, so the calibration procedure does not need any update during normal operation.

No conversion can be performed during this time: The bit ADBSY has to be polled to verify that the calibration is over, and the module is able to start a conversion.

## 15 Serial channels

Serial communication with other microcontrollers, microprocessors, terminals or external peripheral components is provided by up to four serial interfaces: Two asynchronous/synchronous serial channels (ASC0 and ASC1) and two high-speed synchronous serial channel (SSC0 and SSC1). Dedicated baudrate generators set up all standard baudrates without the requirement of oscillator tuning. For transmission, reception and erroneous reception, separate interrupt vectors are provided for ASC0 and SSC0 serial channel. A more complex mechanism of interrupt sources multiplexing is implemented for ASC1 and SSC1 (XBUS mapped).

### 15.1 Asynchronous/synchronous serial interfaces

The asynchronous / synchronous serial interfaces (ASC0 and ASC1) provides serial communication between the ST10F272M and other microcontrollers, microprocessors or external peripherals.

### 15.2 ASCx in asynchronous mode

In asynchronous mode, 8- or 9-bit data transfer, parity generation and the number of stop bits can be selected. Parity framing and overrun error detection is provided to increase the reliability of data transfers. Transmission and reception of data is double-buffered. Full-duplex communication up to 1.25 Mbaud (at 40 MHz of  $f_{CPU}$ ) is supported in this mode.

**Table 37. ASC asynchronous baudrates by reload value and deviation errors ( $f_{CPU} = 40$  MHz)**

S0BRS = '0', $f_{CPU} = 40$ MHz			S0BRS = '1', $f_{CPU} = 40$ MHz		
Baudrate (baud)	Deviation error	Reload value (hex)	Baudrate (baud)	Deviation error	Reload value (hex)
1 250 000	0.0%/0.0%	0000/0000	833 333	0.0%/0.0%	0000/0000
112 000	+1.5%/-7.0%	000A/000B	112 000	+6.3%/-7.0%	0006/0007
56 000	+1.5%/-3.0%	0015/0016	56 000	+6.3%/-0.8%	000D/000E
38 400	+1.7%/-1.4%	001F/0020	38 400	+3.3%/-1.4%	0014/0015
19 200	+0.2%/-1.4%	0040/0041	19 200	+0.9%/-1.4%	002A/002B
9 600	+0.2%/-0.6%	0081/0082	9 600	+0.9%/-0.2%	0055/0056
4 800	+0.2%/-0.2%	0103/0104	4 800	+0.4%/-0.2%	00AC/00AD
2 400	+0.2%/0.0%	0207/0208	2 400	+0.1%/-0.2%	015A/015B
1 200	0.1%/0.0%	0410/0411	1 200	+0.1%/-0.1%	02B5/02B6
600	0.0%/0.0%	0822/0823	600	+0.1%/0.0%	056B/056C
300	0.0%/0.0%	1045/1046	300	0.0%/0.0%	0AD8/0AD9
153	0.0%/0.0%	1FE8/1FE9	102	0.0%/0.0%	1FE8/1FE9

*Note:* The deviation errors given in [Table 37](#) are rounded off. To avoid deviation errors use a baudrate crystal (providing a multiple of the ASC0 sampling frequency).

### 15.3 ASCx in synchronous mode

In synchronous mode, data is transmitted or received synchronously to a shift clock which is generated by the ST10F272M. Half-duplex communication up to 5 Mbaud (at 40 MHz of  $f_{CPU}$ ) is possible in this mode.

**Table 38. ASC synchronous baudrates by reload value and deviation errors ( $f_{CPU} = 40$  MHz)**

S0BRS = '0', $f_{CPU} = 40$ MHz			S0BRS = '1', $f_{CPU} = 40$ MHz		
Baudrate (baud)	Deviation error	Reload value (hex)	Baudrate (baud)	Deviation error	Reload value (hex)
5 000 000	0.0%/0.0%	0000/0000	3 333 333	0.0%/0.0%	0000/0000
112 000	+1.5%/-0.8%	002B/002C	112 000	+2.6%/-0.8%	001C/001D
56 000	+0.3%/-0.8%	0058/0059	56 000	+0.9%/-0.8%	003A/003B
38 400	+0.2%/-0.6%	0081/0082	38 400	+0.9%/-0.2%	0055/0056
19 200	+0.2%/-0.2%	0103/0104	19 200	+0.4%/-0.2%	00AC/00AD
9 600	+0.2%/0.0%	0207/0208	9 600	+0.1%/-0.2%	015A/015B
4 800	+0.1%/0.0%	0410/0411	4 800	+0.1%/-0.1%	02B5/02B6
2 400	0.0%/0.0%	0822/0823	2 400	+0.1%/0.0%	056B/056C
1 200	0.0%/0.0%	1045/1046	1 200	0.0%/0.0%	0AD8/0AD9
900	0.0%/0.0%	15B2/15B3	600	0.0%/0.0%	15B2/15B3
612	0.0%/0.0%	1FE8/1FE9	407	0.0%/0.0%	1FFD/1FFE

*Note:* The deviation errors given in the [Table 38](#) are rounded off. To avoid deviation errors use a baudrate crystal (providing a multiple of the ASC0 sampling frequency).

### 15.4 High speed synchronous serial interfaces

The high-speed synchronous serial interfaces (SSC0 and SSC1) provides flexible high-speed serial communication between the ST10F272M and other microcontrollers, microprocessors or external peripherals.

The SSCx supports full-duplex and half-duplex synchronous communication. The serial clock signal can be generated by the SSCx itself (master mode) or be received from an external master (slave mode). Data width, shift direction, clock polarity and phase are programmable.

This allows communication with SPI-compatible devices. Transmission and reception of data is double-buffered. A 16-bit baudrate generator provides the SSCx with a separate serial clock signal. The serial channel SSCx has its own dedicated 16-bit baudrate generator with 16-bit reload capability, allowing baudrate generation independent from the timers.

[Table 39](#) lists some possible baudrates against the required reload values and the resulting bit times for the 40 MHz CPU clock. The maximum is limited to 8 Mbaud.

**Table 39. Synchronous baudrate and reload values ( $f_{\text{CPU}} = 40 \text{ MHz}$ )**

Baudrate	Bit time	Reload value
Reserved	-	0000h
Can be used only with $f_{\text{CPU}} = 32 \text{ MHz}$ (or lower)	-	0001h
6.6 Mbaud	150 ns	0002h
5 Mbaud	200 ns	0003h
2.5 Mbaud	400 ns	0007h
1 Mbaud	1 $\mu\text{s}$	0013h
100 Kbaud	10 $\mu\text{s}$	00C7h
10 Kbaud	100 $\mu\text{s}$	07CFh
1 Kbaud	1 ms	4E1Fh
306 baud	3.26 ms	FF4Eh

## 16 I<sup>2</sup>C interface

The integrated I<sup>2</sup>C bus module handles the transmission and reception of frames over the two-line SDA/SCL in accordance with the I<sup>2</sup>C Bus specification. The I<sup>2</sup>C module can operate in slave mode, in master mode or in multi-master mode. It can receive and transmit data using 7-bit or 10-bit addressing. Data can be transferred at speeds up to 400 Kbit/s (both standard and fast I<sup>2</sup>C bus modes are supported).

The module can generate three different types of interrupt:

- requests related to bus events, such as start or stop events, or arbitration lost
- requests related to data transmission
- requests related to data reception

These requests are issued to the interrupt controller by three different lines, and identified as error, transmit, and receive interrupt lines.

When the I<sup>2</sup>C module is enabled by setting bit XI2CEN in XPERCON register, pins P4.4 and P4.7 (where SCL and SDA are respectively mapped as alternate functions) are automatically configured as bidirectional open-drain: the value of the external pull-up resistor depends on the application. P4, DP4 and ODP4 cannot influence the pin configuration.

When the I<sup>2</sup>C cell is disabled (clearing bit XI2CEN), P4.4 and P4.7 pins are standard I/O controlled by P4, DP4 and ODP4.

The speed of the I<sup>2</sup>C interface can be selected between standard mode (0 to 100 kHz) and fast I<sup>2</sup>C mode (100 to 400 kHz).

## 17 CAN modules

The two integrated CAN modules (CAN1 and CAN2) are identical and handle the completely autonomous transmission and reception of CAN frames according to the CAN specification V2.0 part B (active). It is based on the C-CAN specification.

Each on-chip CAN module can receive and transmit standard frames with 11-bit identifiers as well as extended frames with 29-bit identifiers.

Because of duplication of the CAN controllers, the following adjustments are to be considered:

- Same internal register addresses of both CAN controllers, but with base addresses differing in address bit A8; separate chip select for each CAN module. Refer to [Chapter 4: Memory organization on page 21](#).
- The CAN1 transmit line (CAN1\_TxD) is the alternate function of the Port P4.6 pin and the receive line (CAN1\_RxD) is the alternate function of the Port P4.5 pin.
- The CAN2 transmit line (CAN2\_TxD) is the alternate function of the Port P4.7 pin and the receive line (CAN2\_RxD) is the alternate function of the Port P4.4 pin.
- Interrupt request lines of the CAN1 and CAN2 modules are connected to the XBUS interrupt lines together with other X-peripherals sharing the four vectors.
- The CAN modules must be selected with corresponding CANxEN bit of XPERCON register before the bit XPEN of SYSCON register is set.
- The reset default configuration is: CAN1 enabled, CAN2 disabled.

*Note:* If one or both CAN modules is used, port 4 cannot be programmed to output all eight segment address lines. Thus, only four segment address lines can be used, reducing the external memory space to 5 Mbytes (1 Mbyte per  $\overline{CS}$  line).

### 17.1 Configuration support

It is possible that both CAN controllers are working on the same CAN bus, supporting together up to 64 message objects. In this configuration, both receive signals and both transmit signals are linked together when using the same CAN transceiver. This configuration is especially supported by providing open drain outputs for the CAN1\_TxD and CAN2\_TxD signals. The open drain function is controlled with the ODP4 register for port P4: in this way it is possible to connect together P4.4 with P4.5 (receive lines) and P4.6 with P4.7 (transmit lines configured to be configured as open-drain).

The user may also internally map both CAN modules on the same pins P4.5 and P4.6. In this way, P4.4 and P4.7 can be used either as general purpose I/O lines, or used for I<sup>2</sup>C interface. This is possible by setting bit CANPAR of the XMISC register. To access this register it is necessary to set bit XMISCEN of the XPERCON register and bit XPEN of the SYSCON register.

### 17.2 CAN bus configurations

Depending on the application, CAN bus configuration may be one single bus with a single or multiple interfaces or a multiple bus with a single or multiple interfaces. The ST10F272M can support both configurations.



### 17.2.1 Single CAN bus

The single CAN bus multiple interfaces configuration may be implemented using two CAN transceivers as shown in [Figure 13](#).

**Figure 13. Connection to single CAN bus via separate CAN transceivers**

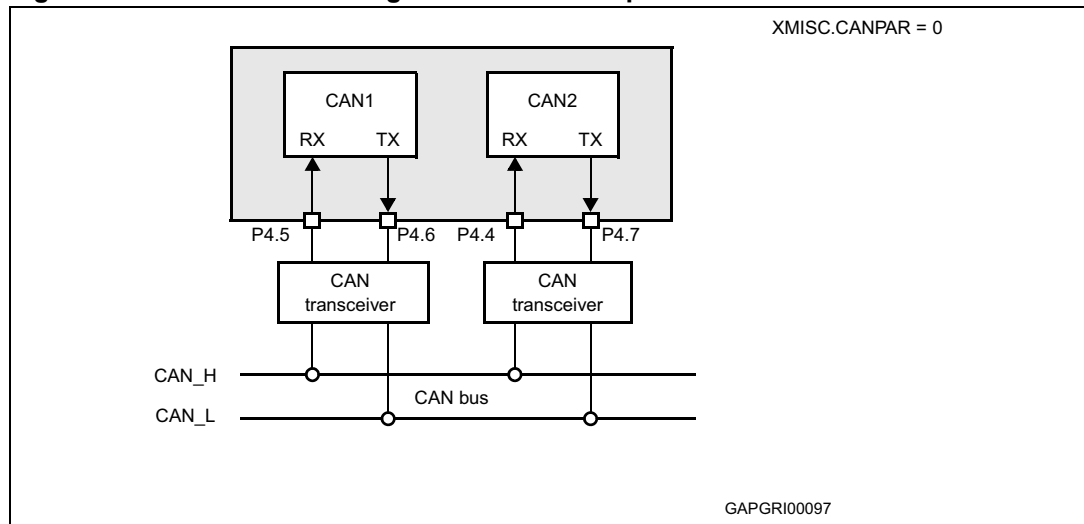

The ST10F272M also supports single CAN bus multiple (dual) interfaces using the open drain option of the CANx\_TxD output as shown in [Figure 14](#). Thanks to the OR-wired connection, only one transceiver is required. In this case the design of the application must take in account the wire length and the noise environment.

**Figure 14. Connection to single CAN bus via common CAN transceivers**

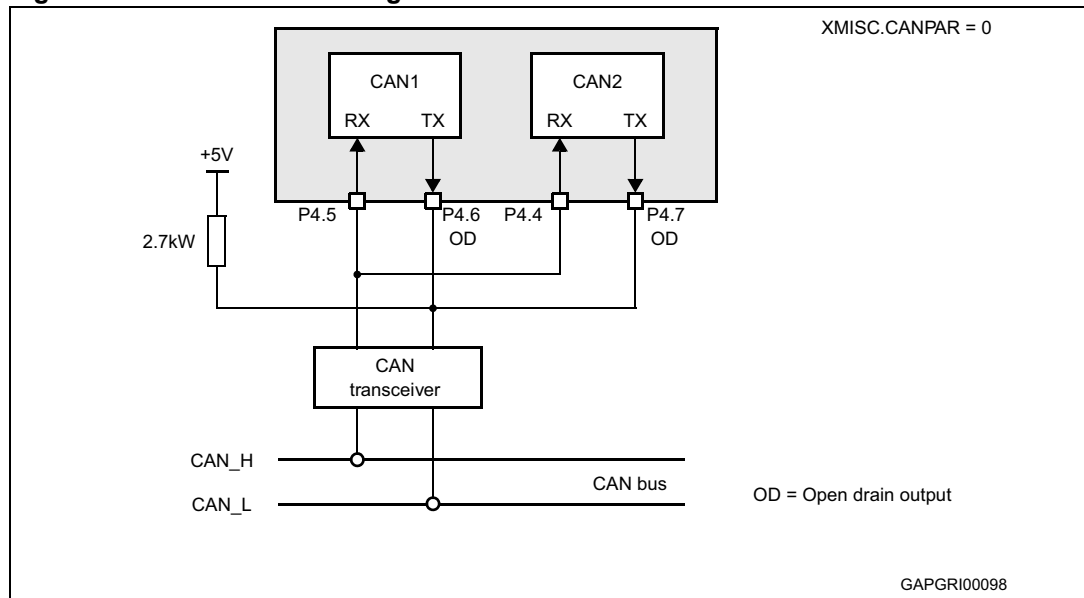

### 17.2.2 Multiple CAN bus

The ST10F272M provides two CAN interfaces to support the kind of bus configuration in [Figure 15](#).

**Figure 15. Connection to two different CAN buses (example, gateway application)**

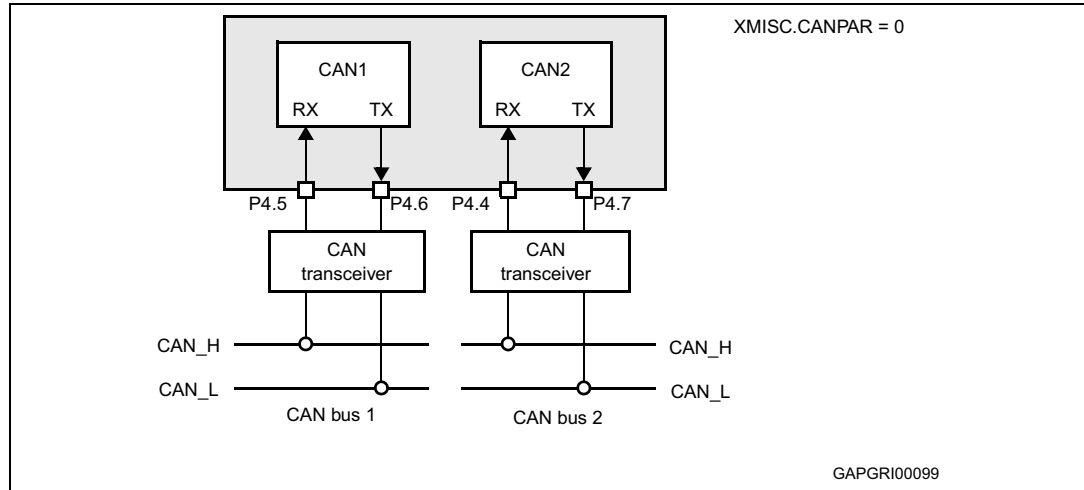

### 17.2.3 Parallel mode

In addition to previous configurations, a parallel mode is supported. This is shown in [Figure 16](#).

**Figure 16. Connection to one CAN bus with internal parallel mode enabled**

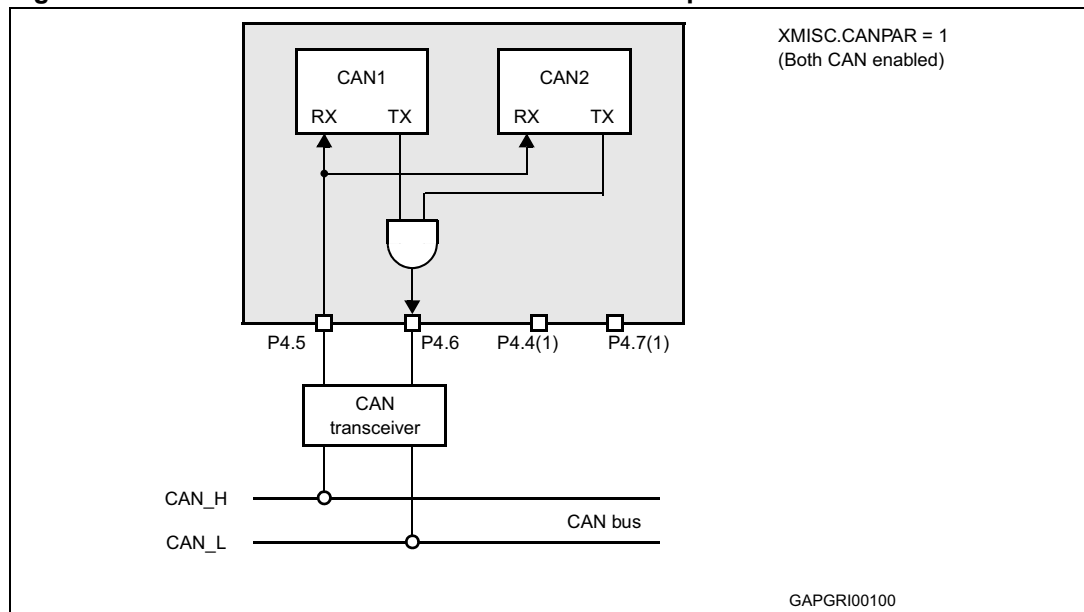

1. P4.4 and P4.7 when not used as CAN functions can be used as general purpose I/O while they cannot be used as external bus address lines.

## 18 Real-time clock

The real-time clock is an independent timer, in which the clock is derived directly from the clock oscillator on XTAL1 (main oscillator) input or XTAL3 input (32 kHz low-power oscillator) so that it can continue running even in Idle or power-down modes (if so enabled). Registers access is implemented onto the XBUS. This module is designed with the following characteristics:

- Generation of the current time and date for the system
- Cyclic time based interrupt, on port2 external interrupts every 'RTC basic clock tick' and after  $n$  'RTC basic clock ticks' ( $n$  is programmable) if enabled
- 58-bit timer for long term measurement
- Capability to exit the ST10 chip from power-down mode (if PWDCFG of SYSCON set) after a programmed delay

The real-time clock is based on two main blocks of counters. The first block is a prescaler which generates a basic reference clock (for example, a 1 second period). This basic reference clock is provided by the 20-bit divider. This 20-bit counter is driven by an input clock derived from the on-chip CPU clock, predivided by a 1/64 fixed counter. This 20-bit counter is loaded at each basic reference clock period with the value of the 20-bit prescaler register. The value of the 20-bit RTCP register determines the period of the basic reference clock.

A timed interrupt request (RTCSI) may be sent on each basic reference clock period. The second block of the RTC is a 32-bit counter that may be initialized with the current system time. This counter is driven with the basic reference clock signal. In order to provide an alarm function the contents of the counter is compared with a 32-bit alarm register. The alarm register may be loaded with a reference date. An alarm interrupt request (RTCAI), may be generated when the value of the counter matches the alarm register.

The timed RTCSI and the alarm RTCAI interrupt requests can trigger a fast external interrupt via the EXISEL register of port 2 and wake up the ST10 chip when running power-down mode. Using the RTCOFF bit of the RTCCON register, the user may switch off the clock oscillator when entering the power-down mode.

The last function implemented in the RTC is to switch off the main on-chip oscillator and the 32 kHz on chip oscillator if the ST10 enters the power-down mode, so that the chip can be fully switched off (if RTC is disabled).

At power-on, and after reset phase, if the presence of a 32 kHz oscillation on XTAL3/XTAL4 pins is detected, then the RTC counter is driven by this low frequency reference clock: when Power-down mode is entered, the RTC can either be stopped or left running, and in both the cases the main oscillator is turned off, reducing the power consumption of the device to the minimum required to keep on running the RTC counter and relative reference oscillator. This is also valid if stand-by mode is entered (switching off the main supply  $V_{DD}$ ), since both the RTC and the low power oscillator (32 kHz) are biased by the  $V_{STBY}$ . Vice versa, when at power on and after Reset, the 32 kHz is not present, the main oscillator drives the RTC counter, and since it is powered by the main power supply, it cannot be maintained running in stand-by mode, while in power-down mode the main oscillator is maintained running to provide the reference to the RTC module (if not disabled).

## 19 Watchdog timer

The watchdog timer is a fail-safe mechanism which prevents the microcontroller from malfunctioning for long periods of time.

The watchdog timer is always enabled after a reset of the chip and can only be disabled in the time interval until the EINIT (end of initialization) instruction has been executed.

Therefore, the chip start-up procedure is always monitored. The software must be designed to service the watchdog timer before it overflows. If, due to hardware or software related failures, the software fails to do so, the watchdog timer overflows and generates an internal hardware reset. It pulls the  $\overline{\text{RSTOUT}}$  pin low in order to allow external hardware components to be reset.

Each of the different reset sources is indicated in the WDTCON register:

- Watchdog timer reset in case of an overflow
- Software reset in case of execution of the SRST instruction
- Short, long and power-on reset in case of hardware reset (and depending of reset pulse duration and RPD pin configuration)

The indicated bits are cleared with the EINIT instruction. The source of the reset can be identified during the initialization phase.

The watchdog timer is 16-bit, clocked with the system clock divided by 2 or 128. The high byte of the watchdog timer register can be set to a prespecified reload value (stored in WDTREL).

Each time it is serviced by the application software, the high byte of the watchdog timer is reloaded. For security, rewrite WDTCON each time before the watchdog timer is serviced

[Table 40](#) shows the watchdog time range for 40 MHz CPU clock.

**Table 40. WDTREL reload value ( $f_{\text{CPU}} = 40 \text{ MHz}$ )**

Reload value in WDTREL	Prescaler for $f_{\text{CPU}} = 40 \text{ MHz}$	
	2 (WDTIN = '0')	128 (WDTIN = '1')
FFh	12.8 $\mu\text{s}$	819.2 $\mu\text{s}$
00h	3.277 ms	209.7 ms

## 20 System reset

System reset initializes the MCU in a predefined state. There are six ways to activate a reset state. The system start-up configuration is different for each case as shown in [Table 41](#).

**Table 41. Reset event definition**

Reset source	Flag	RPD status	Conditions
Power-on reset	PONR	Low	Power-on
Asynchronous hardware reset	LHWR	Low	$t_{\overline{\text{RSTIN}}} >^{(1)}$
Synchronous long hardware reset		High	$t_{\overline{\text{RSTIN}}} > (1032 + 12) \text{ TCL} + \max(4 \text{ TCL}, 500\text{ns})^{(2)}$
Synchronous short hardware reset	SHWR	High	$t_{\overline{\text{RSTIN}}} > \max(4 \text{ TCL}, 500\text{ns})^{(2)}$ $t_{\overline{\text{RSTIN}}} \leq (1032 + 12) \text{ TCL} + \max(4 \text{ TCL}, 500\text{ns})^{(2)}$
Watchdog timer reset	WDTR	<sup>(3)</sup>	WDT overflow
Software reset	SWR	<sup>(3)</sup>	SRST instruction execution

- $\overline{\text{RSTIN}}$  pulse should be longer than 500 ns (filter) and than settling time for configuration of Port0.
- See next [Section 20.1](#) for more details on minimum reset pulse duration.
- The RPD status has no influence unless bidirectional reset is activated (bit `BDRSTEN` in `SYSCON`): RPD low inhibits the bidirectional reset on SW and WDT reset events, that is  $\overline{\text{RSTIN}}$  is not activated (refer to [Sections 20.4, 20.5 and 20.6](#)).

The figures in the upcoming sections [20.2](#), [20.3](#), [20.5](#) and [20.6](#) use the following terminology:

- Transparent: Level of the pin affects the internal reset logic
- Not transparent: Level of the pin does not affect internal logic

### 20.1 Input filter

On the  $\overline{\text{RSTIN}}$  input pin an on-chip RC filter is implemented. It is sized to filter all spikes shorter than 50ns. On the other hand, a valid pulse longer than 500 ns is required for the ST10 to recognize a reset command. In between 50 ns and 500 ns a pulse can either be filtered or recognized as valid, depending on the operating conditions and process variations.

For this reason all minimum durations mentioned in this chapter for the different kinds of reset events must be carefully evaluated, taking into account the above requirements.

In particular, for short hardware reset, where only 4 TCL is specified as minimum input reset pulse duration, the operating frequency is a key factor.

Examples:

- For a CPU clock of 40 MHz, 4 TCL is 50 ns, so it would be filtered. In this case the minimum becomes the one imposed by the filter (that is 500 ns).
- For a CPU clock of 4 MHz, 4 TCL is 500 ns. In this case the minimum from the formula is coherent with the limit imposed by the filter.

## 20.2 Asynchronous reset

An asynchronous reset is triggered when  $\overline{\text{RSTIN}}$  pin is pulled low while RPD pin is at low level. Then the ST10F272M is immediately (after the input filter delay) forced in reset default state. It pulls low RSTOUT pin, it cancels pending internal hold states if any, it aborts all internal/external bus cycles, it switches buses (data, address and control signals) and I/O pin drivers to high-impedance, it pulls high port0 pins.

*Note: If an asynchronous reset occurs during a read or write phase in internal memories, the content of the memory itself could be corrupted: to avoid this, synchronous reset usage is strongly recommended.*

### Power-on reset

The asynchronous reset must be used during the power-on of the device. Depending on crystal or resonator frequency, the on-chip oscillator needs about 1ms to 10 ms to stabilize (refer to [Section 24: Electrical characteristics](#)), with an already stable  $V_{DD}$ . The logic of the ST10F272M does not need a stabilized clock signal to detect an asynchronous reset, so it is suitable for power-on conditions. To ensure a proper reset sequence, the  $\overline{\text{RSTIN}}$  pin and the RPD pin must be held at low level until the device clock signal is stabilized and the system configuration value on port0 is settled.

At power-on it is important to respect some additional constraints introduced by the start-up phase of the different embedded modules.

In particular, the on-chip voltage regulator needs at least 1ms to stabilize the internal 1.8 V for the core logic: This time is computed from when the external reference ( $V_{DD}$ ) becomes stable (inside specification range, that is, at least 4.5 V). This is a constraint for the application hardware (external voltage regulator): The  $\overline{\text{RSTIN}}$  pin assertion has to be extended to guarantee the voltage regulator stabilization.

A second constraint is imposed by the embedded Flash. When booting from internal memory, starting from  $\overline{\text{RSTIN}}$  releasing, it needs a maximum of 1ms for its initialization: before that, the internal reset (RST signal) is not released, so the CPU does not start code execution in internal memory.

*Note: This is not true if external memory is used (pin  $\overline{\text{EA}}$  held low during reset phase). In this case, once the  $\overline{\text{RSTIN}}$  pin is released, and after a few CPU clock cycles (Filter delay plus 3...8 TCL), the internal reset signal RST is released as well, so the code execution can start immediately after. Obviously, an eventual access to the data in internal Flash is forbidden before its initialization phase is completed: An eventual access during starting phase will return FFFh (just at the beginning), while later 009Bh (an illegal opcode trap can be generated).*

At power-on, the  $\overline{\text{RSTIN}}$  pin must be tied low for a minimum time that also includes the start-up time of the main oscillator ( $t_{\text{STUP}} = 1\text{ms}$  for resonator, 10ms for crystal) and PLL synchronization time ( $t_{\text{PSUP}} = 200\ \mu\text{s}$ ): This means if the internal Flash is used, the  $\overline{\text{RSTIN}}$  pin could be released before the main oscillator and PLL are stable to recover some time in the start-up phase (Flash initialization only needs stable  $V_{18}$ , but does not need stable system clock since an internal dedicated oscillator is used).

---

**Warning:** It is recommended to provide the external hardware with a current limitation circuitry. This is necessary to avoid permanent damage of the device during the power-on transient, when the capacitance on V<sub>18</sub> pin is charged. For the on-chip voltage regulator functionality 10nF is sufficient: In any case, a maximum of 100 nF on V<sub>18</sub> pin should not generate problems of over-current (higher value is allowed if current is limited by the external hardware). External current limitation is nevertheless also recommended to avoid risks of damage in case of a temporary short between V<sub>18</sub> and ground: The internal 1.8 V drivers are sized to drive currents of several tens of Amps, so the current must be limited by the external hardware. The limit of current is imposed by power dissipation considerations (refer to [Section 24: Electrical characteristics](#)).

---

In figures [17](#) and [18](#) below, asynchronous power-on timing diagrams are shown, with boot from internal or external memory respectively, highlighting the reset phase extension introduced by the embedded Flash module when selected.

**Caution:** Never power the device without keeping the RSTIN pin grounded: The device could enter into unpredictable states, risking also permanent damage.

Figure 17. Asynchronous power-on reset ( $\overline{EA} = 1$ )

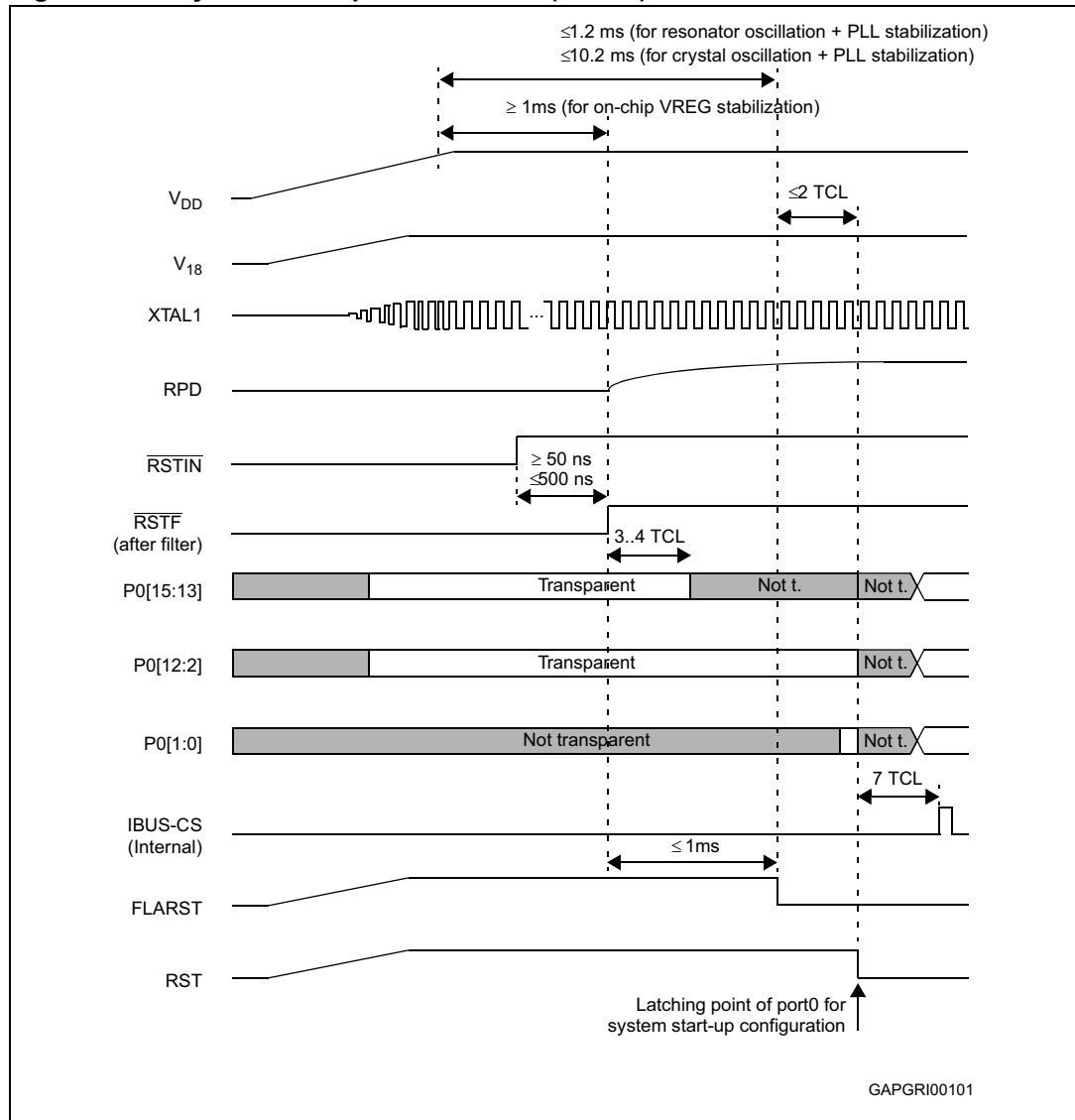
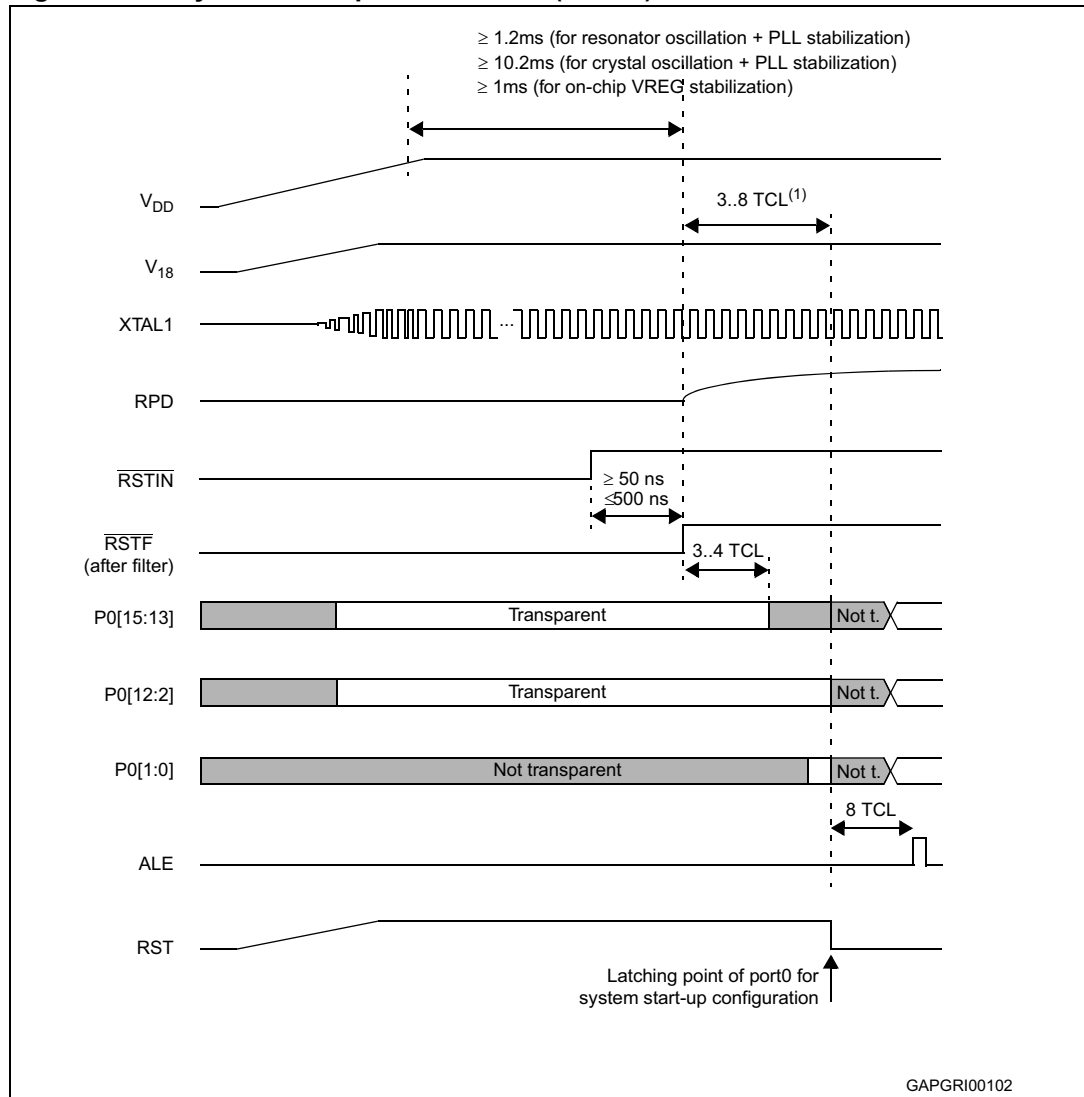



Figure 18. Asynchronous power-on reset ( $\overline{EA} = 0$ )



1. 3 to 8 TCL depending on clock source selection

### Hardware reset

The asynchronous reset must be used to recover from catastrophic situations of the application. It may be triggered by the hardware of the application. Internal hardware logic and application circuitry are described in the reset circuitry chapter and in figures 30, 31 and 32. It occurs when  $\overline{RSTIN}$  is low and RPD is detected (or becomes) low as well.

Figure 19. Asynchronous hardware reset ( $\overline{EA} = 1$ )

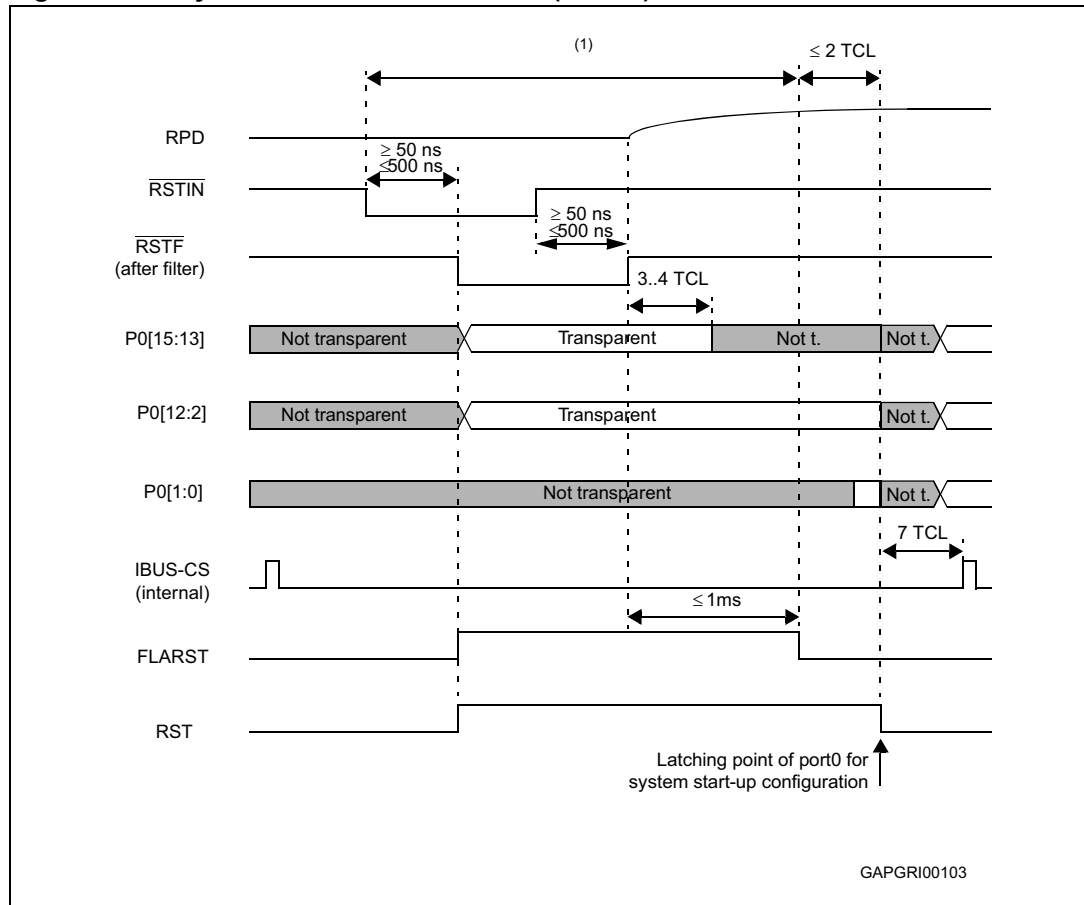

1. Longer than port0 settling time + PLL synchronization (if needed, that is P0(15:13) changed). Longer than 500 ns to take account of input filter on RSTIN pin.

Figure 20. Asynchronous hardware reset ( $\overline{EA} = 0$ )

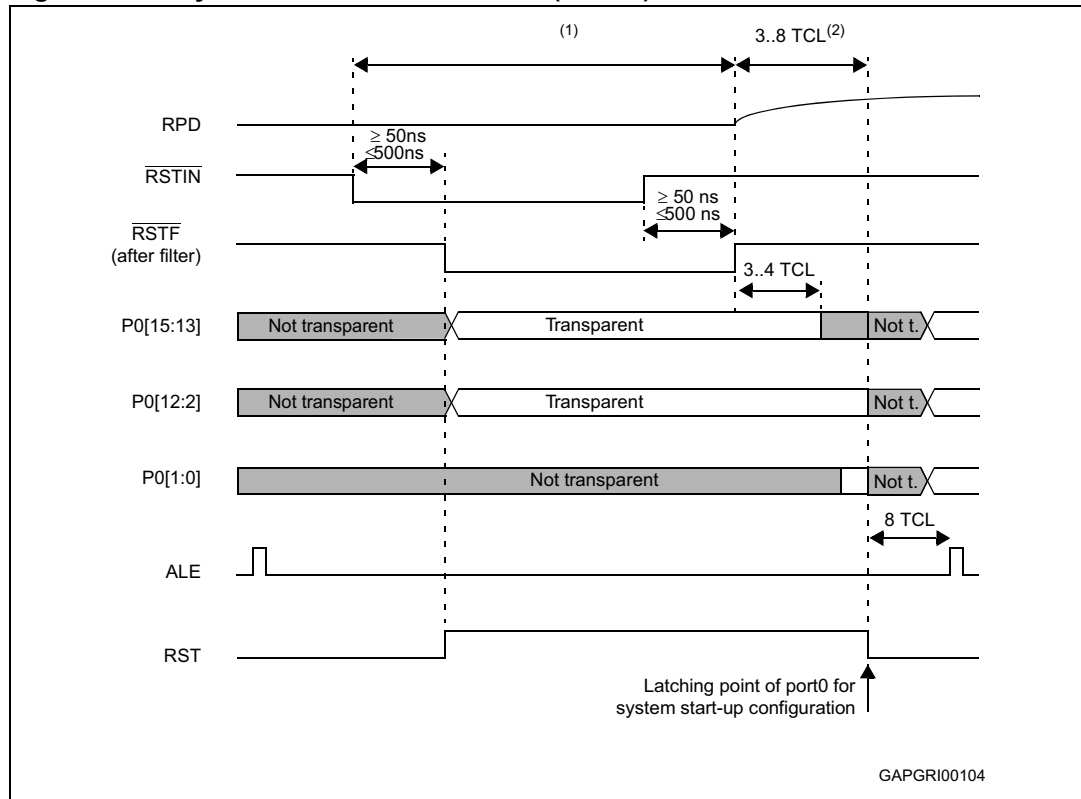

1. Longer than port0 settling time + PLL synchronization (if needed, that is P0(15:13) changed). Longer than 500 ns to take account input filter on RSTIN pin.
2. 3 to 8 TCL depending on clock source selection.

### Exit from asynchronous reset state

When the  $\overline{RSTIN}$  pin is pulled high, the device restarts: As already mentioned, if internal Flash is used, the restarting occurs after the embedded Flash initialization routine is completed. The system configuration is latched from Port0: ALE,  $\overline{RD}$  and  $\overline{WR/WRL}$  pins are driven to their inactive level. The ST10F272M starts program execution from memory location 00'0000h in code segment 0. This starting location will typically point to the general initialization routine. The timings of asynchronous hardware reset sequence are summarized in [Figure 19](#) and [Figure 20](#).

## 20.3 Synchronous reset (warm reset)

A synchronous reset is triggered when  $\overline{RSTIN}$  pin is pulled low while RPD pin is at high level. In order to properly activate the internal reset logic of the device, the  $\overline{RSTIN}$  pin must be held low, at least, during 4 TCL (two periods of CPU clock): Refer also to [Section 20.1](#) for details on minimum reset pulse duration. The I/O pins are set to high impedance and  $\overline{RSTOUT}$  pin is driven low. After  $\overline{RSTIN}$  level is detected, a short duration of a maximum of 12 TCL (six periods of CPU clock) elapses, during which pending internal hold states are cancelled and the current internal access cycle if any is completed. External bus cycle is aborted. The internal pull-down of  $\overline{RSTIN}$  pin is activated if bit BDRSTEN of SYSCON register was previously set by software. Note that this bit is always cleared on power-on or after a reset sequence.

### Short and long synchronous reset

Once the first maximum 16 TCL are elapsed (4+12 TCL), the internal reset sequence starts. It is 1024 TCL cycles long. At the end of it, and after another 8 TCL the level of  $\overline{\text{RSTIN}}$  is sampled (after the filter, see  $\overline{\text{RSTF}}$  in the drawings). If it is already at high level, only a short reset is flagged (refer to [Chapter 19](#) for details on reset flags). If it is still low, a long reset is flagged as well. The major difference between long and short resets is that during the long reset, P0(15:13) becomes transparent, so it is possible to change the clock options.

---

**Warning:** In case of a short pulse on  $\overline{\text{RSTIN}}$  pin, and when bidirectional reset is enabled, the  $\overline{\text{RSTIN}}$  pin is held low by the internal circuitry. At the end of the 1024 TCL cycles, the  $\overline{\text{RSTIN}}$  pin is released, but due to the presence of the input analog filter the internal input reset signal ( $\overline{\text{RSTF}}$  in the drawings) is released later (from 50 to 500 ns). This delay is in parallel with the additional 8 TCL, at the end of which the internal input reset line ( $\overline{\text{RSTF}}$ ) is sampled, to decide if the reset event is short or long.

---

- If 8 TCL > 500 ns ( $f_{\text{CPU}} < 8$  MHz), the reset event is always recognized as short
- If 8 TCL < 500 ns ( $f_{\text{CPU}} > 8$  MHz), the reset event could be recognized either as short or long, depending on the real filter delay (between 50 and 500 ns) and the CPU frequency ( $\overline{\text{RSTF}}$  sampled high means short reset,  $\overline{\text{RSTF}}$  sampled low means long reset). Note that in case a long reset is recognized, once the 8 TCL are elapsed, the P0(15:13) pins becomes transparent, so the system clock can be reconfigured. The port returns not transparent 3-4 TCL after the internal  $\overline{\text{RSTF}}$  signal becomes high.

The same behavior just described, occurs also when unidirectional reset is selected and  $\overline{\text{RSTIN}}$  pin is held low till the end of the internal sequence (exactly 1024 TCL + max 16 TCL) and released exactly at that time.

*Note:* When running with CPU frequency lower than 40 MHz, the minimum valid reset pulse to be recognized by the CPU (4 TCL) could be longer than the minimum analog filter delay (50 ns); so it might happen that a short reset pulse is not filtered by the analog input filter, but on the other hand it is not long enough to trigger a CPU reset (shorter than 4 TCL): this would generate a Flash reset but not a system reset. In this condition, the Flash answers always with FFFFh, which leads to an illegal opcode and consequently a trap event is generated.

### Exit from synchronous reset state

The reset sequence is extended until the  $\overline{\text{RSTIN}}$  level becomes high. Moreover, it is internally prolonged by the Flash initialization when  $\overline{\text{EA}} = 1$  (internal memory selected). Then, the code execution restarts. The system configuration is latched from port0, and ALE,  $\overline{\text{RD}}$  and  $\overline{\text{WR/WRL}}$  pins are driven to their inactive level. The ST10F272M starts program execution from memory location 00'0000h in code segment 0. This starting location will typically point to the general initialization routine. Timing of synchronous reset sequence are summarized in figures [21](#) and [22](#) where a short reset event is shown, with particular emphasis on the fact that it can degenerate into long reset. The two figures show the behavior when booting from internal or external memory respectively. Figures [23](#) and [24](#) report the timing of a typical synchronous long reset, again when booting from internal or external memory.

### Synchronous reset and RPD pin

Whenever the  $\overline{\text{RSTIN}}$  pin is pulled low (by external hardware or as a consequence of a Bidirectional reset), the RPD internal weak pull-down is activated. The external capacitance (if any) on RPD pin is slowly discharged through the internal weak pull-down. If the voltage level on RPD pin reaches the input low threshold (approximately 2.5 V), the reset event becomes immediately asynchronous. In case of hardware reset (short or long) the situation goes immediately to the one illustrated in [Figure 19](#). There is no effect if RPD comes again above the input threshold: the asynchronous reset is completed coherently. To correctly complete a synchronous reset, the value of the capacitance must be big enough to maintain a sufficiently high voltage on the RPD pin for the duration of the internal reset sequence.

For a software or watchdog reset events, an active synchronous reset is completed regardless of the RPD status.

It is important to highlight that the signal that makes RPD status transparent under reset is the internal  $\overline{\text{RSTF}}$  (after the noise filter).

**Figure 21. Synchronous short/long hardware reset ( $\overline{\text{EA}} = 1$ )**

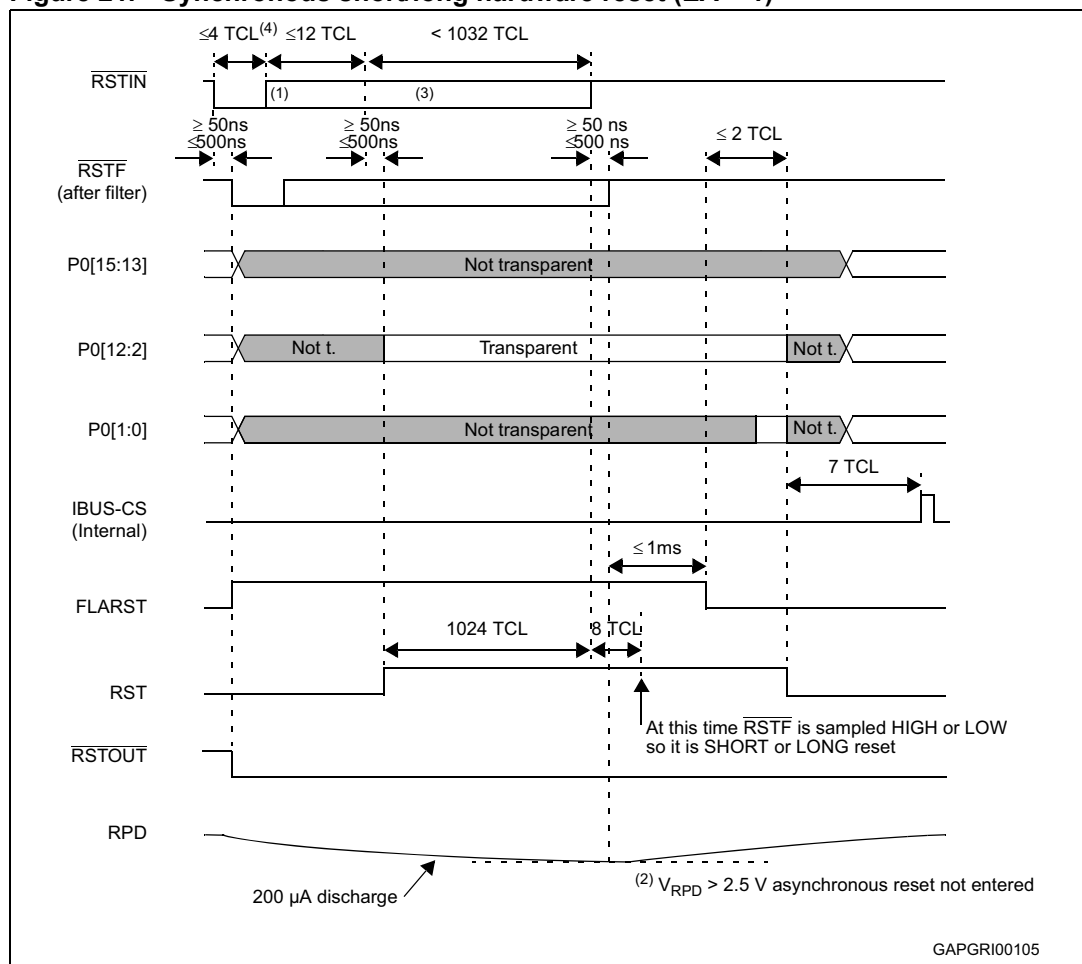

1. RSTIN assertion can be released there. Refer also to [Section 21.1](#) for details on minimum pulse duration.
2. If during the reset condition (RSTIN low), RPD voltage drops below the threshold voltage (about 2.5V for 5V operation), the asynchronous reset is then immediately entered.
3. RSTIN pin is pulled low if bit BDRSTEN (bit 3 of SYSCON register) was previously set by software. Bit

BDRSTEN is cleared after reset.

- Minimum RSTIN low pulse duration shall also be longer than 500ns to guarantee the pulse is not masked by the internal filter (refer to [Section 21.1](#))

**Figure 22. Synchronous short/long hardware reset ( $\overline{EA} = 0$ )**

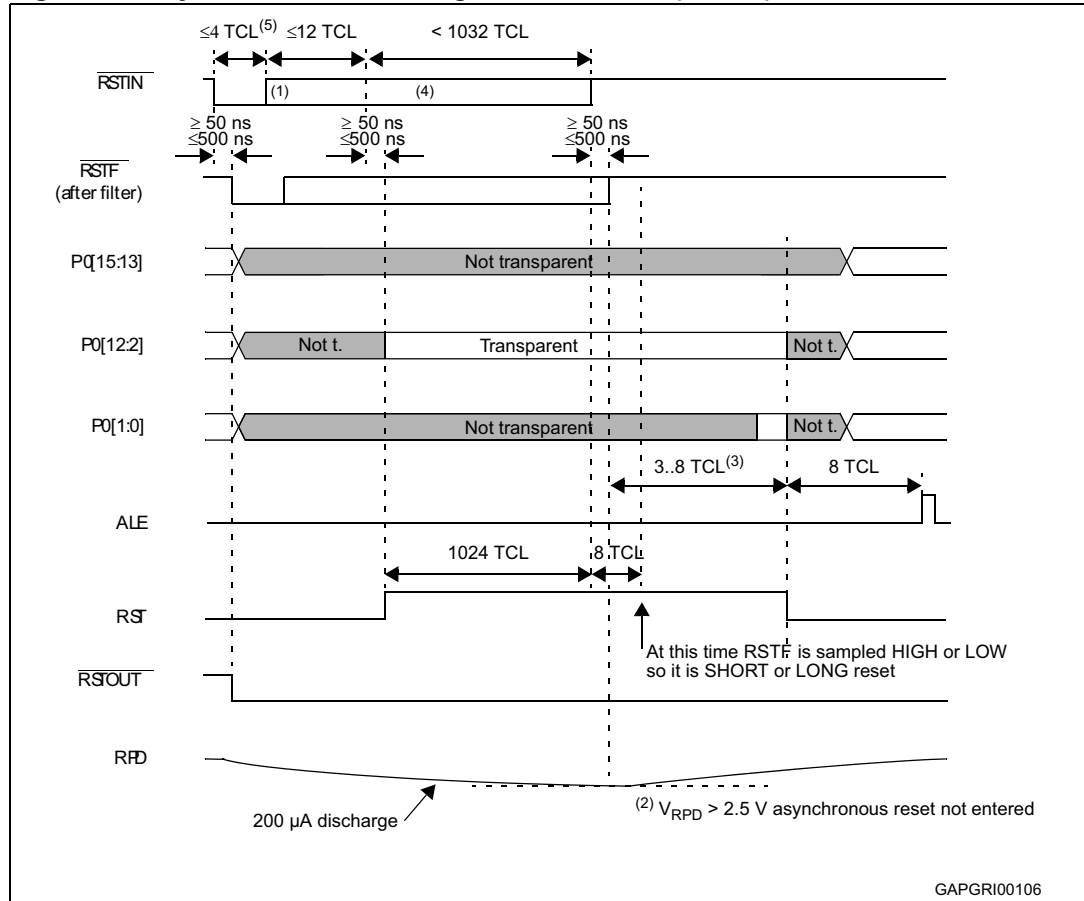

- RSTIN assertion can be released there. Refer also to [Section 21.1](#) for details on minimum pulse duration.
- If during the reset condition (RSTIN low), RPD voltage drops below the threshold voltage (about 2.5V for 5V operation), the asynchronous reset is then immediately entered.
- 3 to 8 TCL depending on clock source selection.
- RSTIN pin is pulled up if bit BDRSTEN (bit 3 of SYSCON register) was previously set by software. Bit BDRSTEN is cleared after reset.
- Minimum RSTIN low pulse duration shall also be longer than 500ns to guarantee the pulse is not masked by the internal filter (refer to [Section 21.1](#)).

Figure 23. Synchronous long hardware reset ( $\overline{EA} = 1$ )

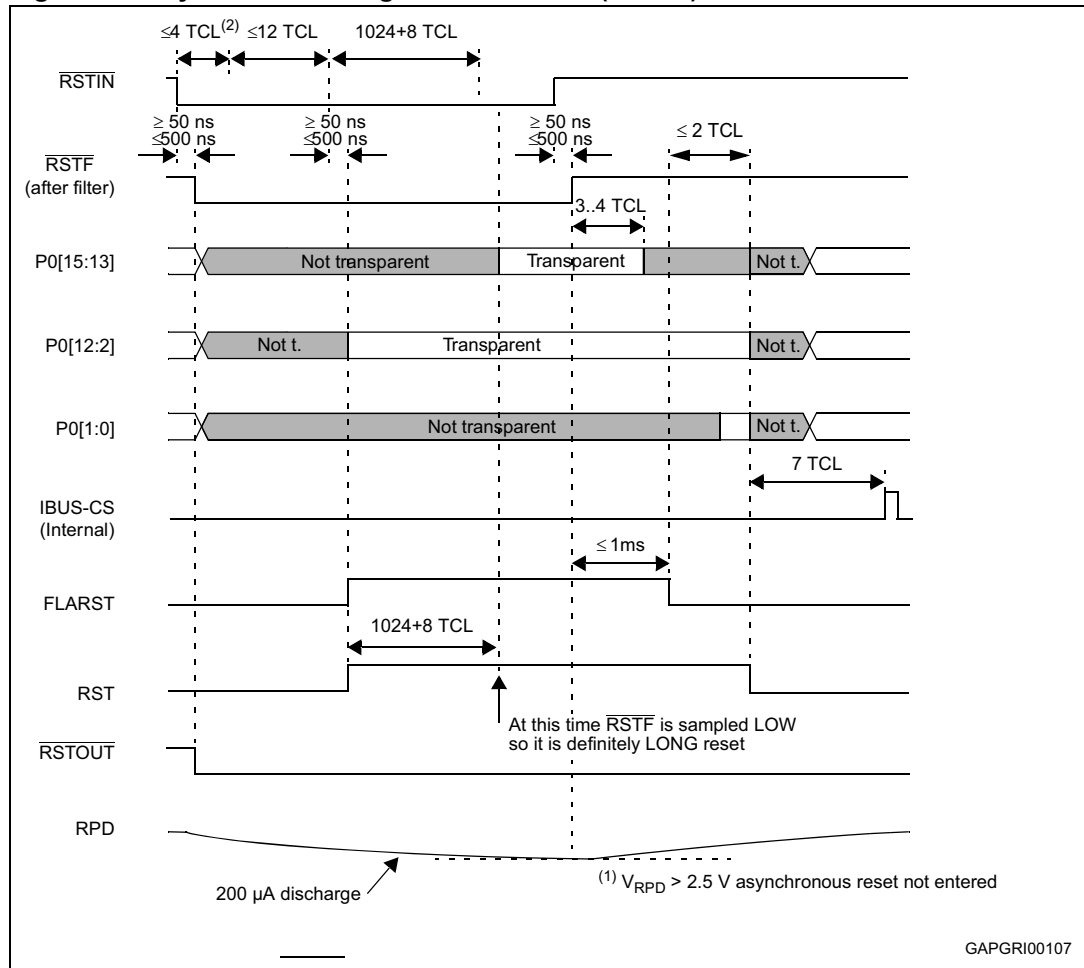

1. If during the reset condition ( $\overline{RSTIN}$  low), RPD voltage drops below the threshold voltage (about 2.5 V for 5V operation), the asynchronous reset is then immediately entered. Even if RPD returns above the threshold, the reset is definitively taken as asynchronous.
2. Minimum  $\overline{RSTIN}$  low pulse duration shall also be longer than 500 ns to guarantee the pulse is not masked by the internal filter (refer to [Section 21.1](#)).

Figure 24. Synchronous long hardware reset ( $\overline{EA} = 0$ )

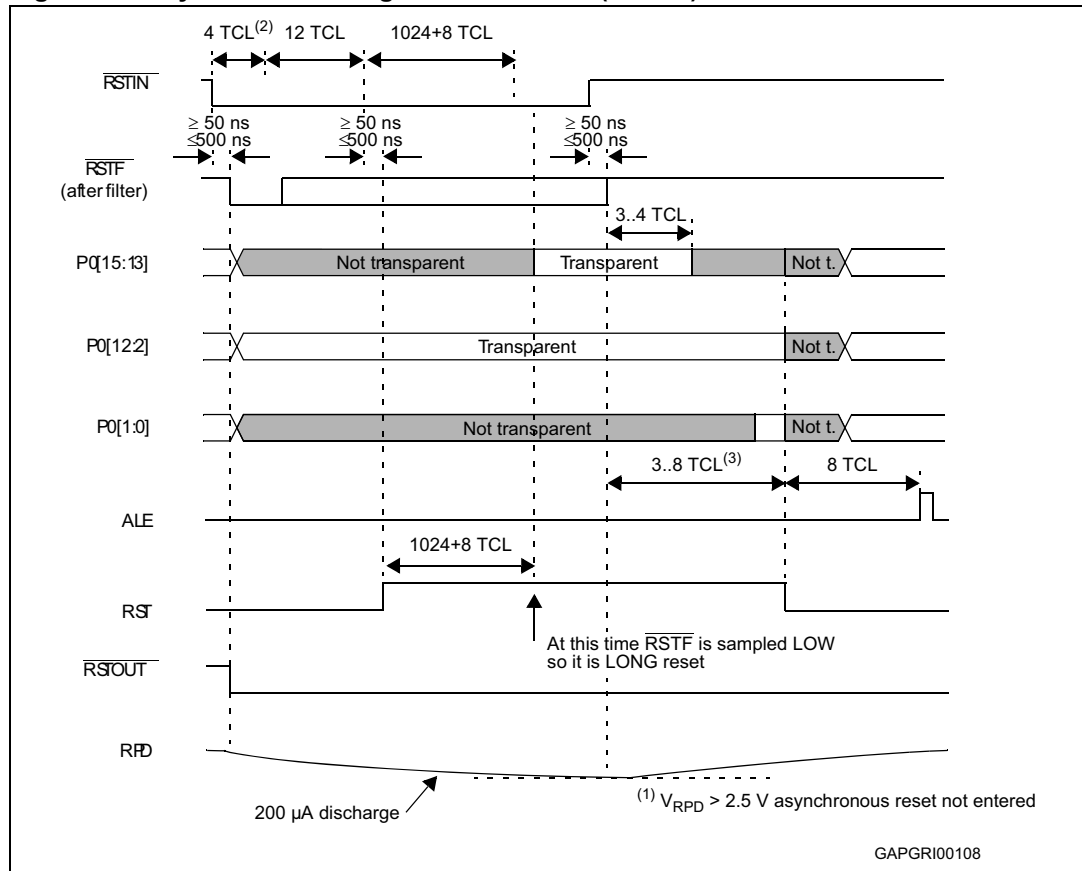

1. If during the reset condition ( $\overline{RSTIN}$  low), RPD voltage drops below the threshold voltage (about 2.5 V for 5 V operation), the asynchronous reset is then immediately entered.
2. Minimum  $\overline{RSTIN}$  low pulse duration shall also be longer than 500 ns to guarantee the pulse is not masked by the internal filter (refer to [Section 21.1](#)).
3. 3 to 8 TCL depending on clock source selection.

## 20.4 Software reset

A software reset sequence can be triggered at any time by the protected SRST (software reset) instruction. This instruction can be deliberately executed within a program, for example, to leave bootstrap loader mode, or on a hardware trap that reveals system failure.

On execution of the SRST instruction, the internal reset sequence is started. The microcontroller behavior is the same as for a synchronous short reset, except that only bits P0.12...P0.8 are latched at the end of the reset sequence, while previously latched, bits P0.7...P0.2 are cleared (that is written at '1').

A software reset is always taken as synchronous: there is no influence on Software Reset behavior with RPD status. In case Bidirectional Reset is selected, a Software Reset event pulls  $\overline{RSTIN}$  pin low: this occurs only if RPD is high; if RPD is low,  $\overline{RSTIN}$  pin is not pulled low even though Bidirectional Reset is selected.

Refer to the figures [Figure 25](#) and [Figure 26](#) for unidirectional SW reset timing, and to figures [Figure 27](#), [Figure 28](#) and [Figure 29](#) for bidirectional.



## 20.5 Watchdog timer reset

When the watchdog timer is not disabled during the initialization, or serviced regularly during program execution, it will overflow and trigger the reset sequence.

Unlike hardware and software resets, the watchdog reset completes a running external bus cycle if this bus cycle either does not use  $\overline{\text{READY}}$ , or if  $\overline{\text{READY}}$  is sampled active (low) after the programmed wait states.

When  $\overline{\text{READY}}$  is sampled inactive (high) after the programmed wait states the running external bus cycle is aborted. Then the internal reset sequence is started.

Bit P0.12...P0.8 are latched at the end of the reset sequence and bit P0.7...P0.2 are cleared (that is written at '1').

A Watchdog reset is always taken as synchronous: there is no influence on watchdog reset behavior with RPD status. In case bidirectional reset is selected, a watchdog reset event pulls  $\overline{\text{RSTIN}}$  pin low: this occurs only if RPD is high; if RPD is low,  $\overline{\text{RSTIN}}$  pin is not pulled low even though bidirectional reset is selected.

Refer to figures [Figure 25](#) and [Figure 26](#) for unidirectional SW reset timing, and to figures [Figure 27](#), [Figure 28](#) and [Figure 29](#) for bidirectional.

**Figure 25. SW/WDT unidirectional reset ( $\overline{\text{EA}} = 1$ )**

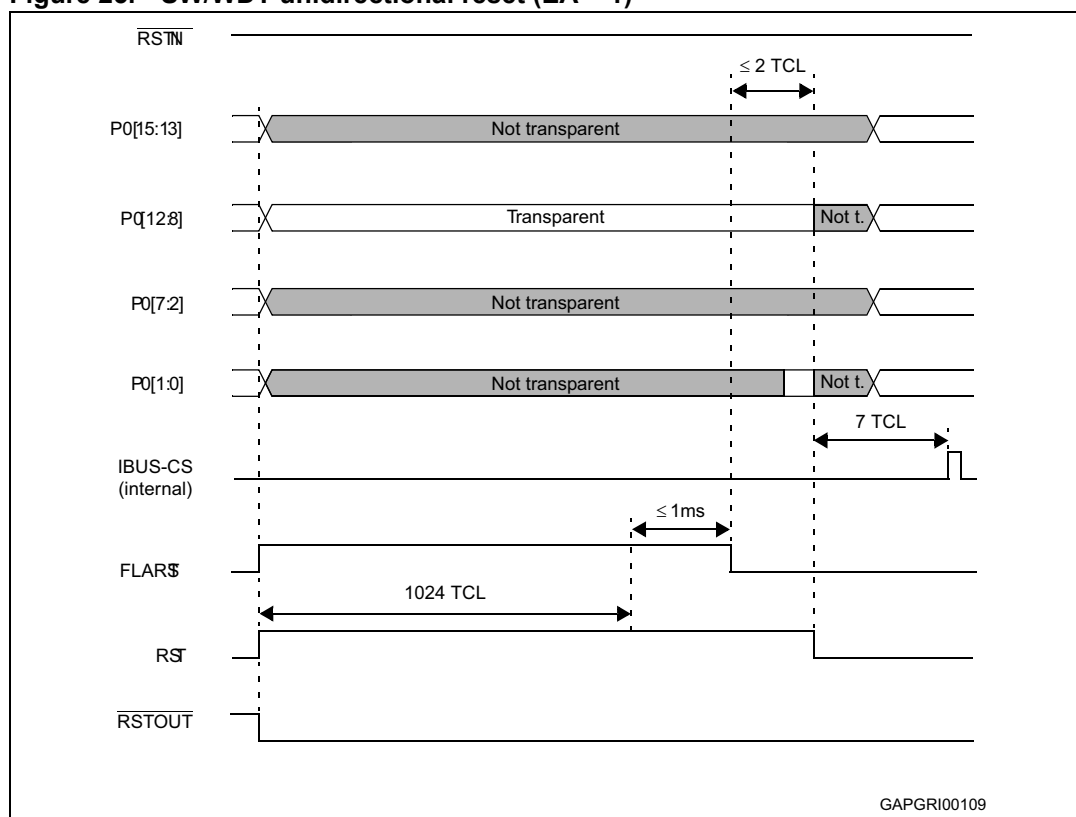
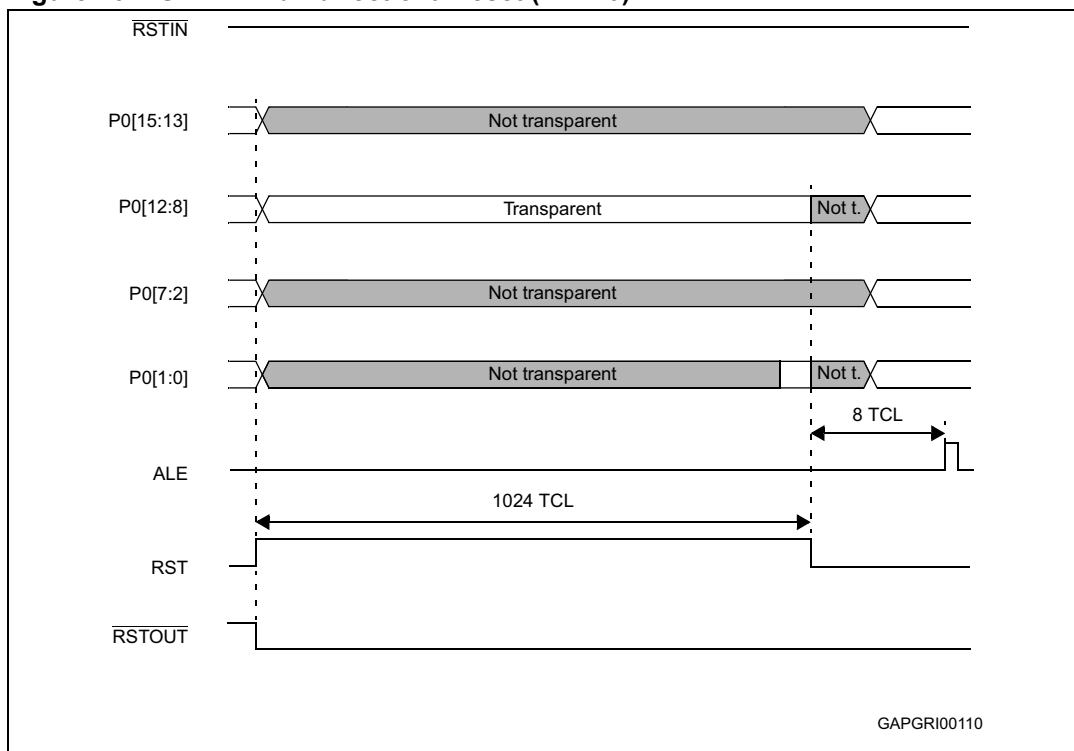

Figure 26. SW/WDT unidirectional reset ( $\overline{EA} = 0$ )



## 20.6 Bidirectional reset

As shown in the previous sections, the  $\overline{RSTOUT}$  pin is driven active (low level) at the beginning of any reset sequence (synchronous/asynchronous hardware, software and watchdog timer resets).  $\overline{RSTOUT}$  pin stays active low beyond the end of the initialization routine, until the protected EINIT instruction (end of initialization) is completed.

The bidirectional reset function is useful when external devices require a reset signal but cannot be connected to  $\overline{RSTOUT}$  pin, because  $\overline{RSTOUT}$  signal lasts during initialization. It is, for instance, the case of external memory running initialization routine before the execution of EINIT instruction.

Bidirectional reset function is enabled by setting bit 3 (BDRSTEN) in SYSCON register. It only can be enabled during the initialization routine, before EINIT instruction is completed.

When enabled, the open drain of the  $\overline{RSTIN}$  pin is activated, pulling down the reset signal, for the duration of the internal reset sequence (synchronous/asynchronous hardware, synchronous software and synchronous watchdog timer resets). At the end of the internal reset sequence the pull down is released and:

- After a short synchronous bidirectional hardware reset, if  $\overline{RSTF}$  is sampled low eight TCL periods after the internal reset sequence completion (refer to [Figure 21](#) and [Figure 22](#)), the short reset becomes a long reset. On the contrary, if  $\overline{RSTF}$  is sampled high the device simply exits reset state.
- After a software or watchdog bidirectional reset, the device exits from reset. If  $\overline{RSTF}$  remains still low for at least four TCL periods (minimum time to recognize a short hardware reset) after the reset exiting (refer to [Figure 27](#) and [Figure 28](#)), the software

or watchdog reset become a short hardware reset. On the contrary, if  $\overline{\text{RSTF}}$  remains low for less than 4 TCL, the device simply exits reset state.

The bidirectional reset is not effective in case RPD is held low, when a software or watchdog reset event occurs. On the contrary, if a software or watchdog bidirectional reset event is active and RPD becomes low, the  $\overline{\text{RSTIN}}$  pin is immediately released, while the internal reset sequence is completed regardless of RPD status change (1024 TCL).

*Note: The bidirectional reset function is disabled by any reset sequence (bit BDRSTEN of SYSCON is cleared). To be activated again it must be enabled during the initialization routine.*

### WDTCN flags

Similar to what is highlighted in the previous section, when discussing short reset and the degeneration into long reset, comparable situations may occur when bidirectional reset is enabled. The presence of the internal filter on  $\overline{\text{RSTIN}}$  pin introduces a delay: When  $\overline{\text{RSTIN}}$  is released, the internal signal after the filter (see RSTF in the drawings) is delayed, so it remains still active (low) for a while. It means that depending on the internal clock speed, a short reset may be recognized as a long reset: The WDTCN flags are set accordingly.

Moreover, when either software or watchdog bidirectional reset events occur, when the  $\overline{\text{RSTIN}}$  pin is released (at the end of the internal reset sequence), the  $\overline{\text{RSTF}}$  internal signal (after the filter) remains low for a while, and depending on the clock frequency it is recognized high or low: 8TCL after the completion of the internal sequence, the level of  $\overline{\text{RSTF}}$  signal is sampled, and if recognized still low a hardware reset sequence starts, and WDTCN will flag this last event, masking the previous one (software or watchdog reset). Typically, a short hardware reset is recognized, unless the  $\overline{\text{RSTIN}}$  pin (and consequently internal signal  $\overline{\text{RSTF}}$ ) is sufficiently held low by the external hardware to inject a long hardware reset. After this occurrence, the initialization routine is not able to recognize a software or watchdog bidirectional reset event, since a different source is flagged inside WDTCN register. This phenomenon does not occur when internal Flash is selected during reset ( $\overline{\text{EA}} = 1$ ), since the initialization of the Flash itself extend the internal reset duration well beyond the filter delay.

Figures [Figure 27](#), [Figure 28](#) and [Figure 29](#) summarize the timing for software and watchdog timer bidirectional reset events: In particular [Figure 29](#) shows the degeneration into hardware reset.

Figure 27. SW/WDT bidirectional reset ( $\overline{EA} = 1$ )

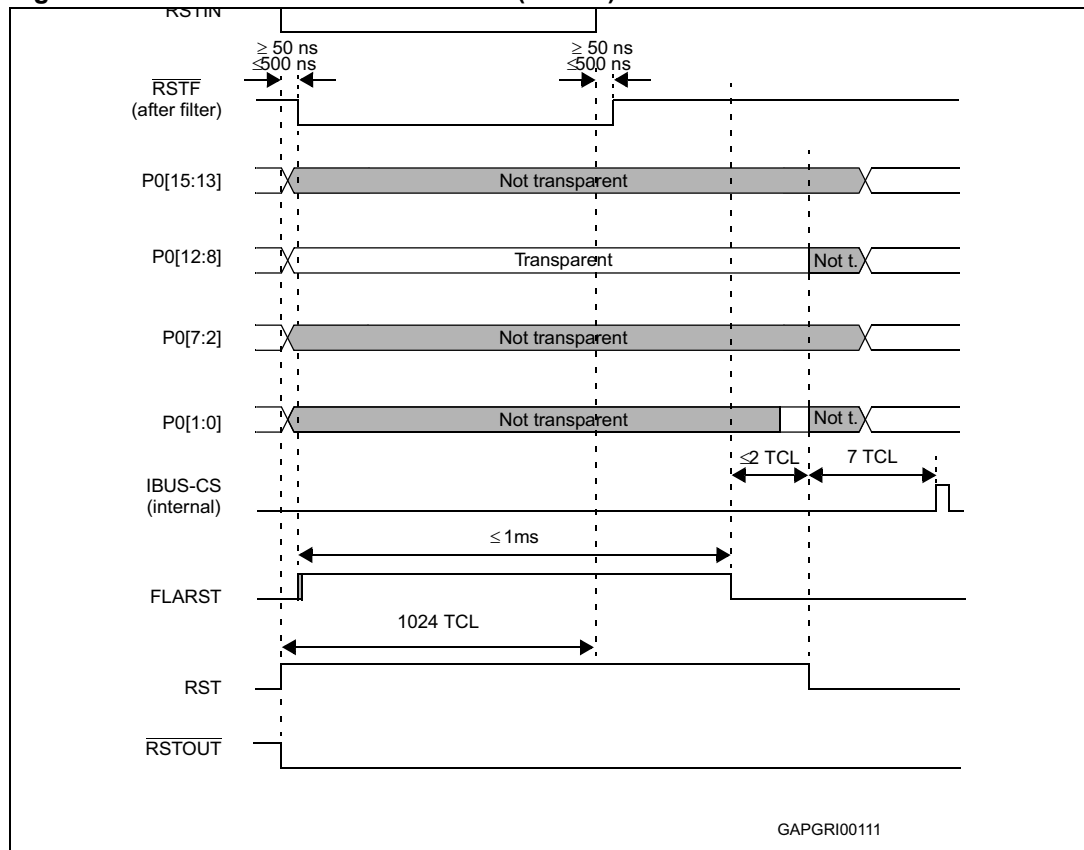

Figure 28. SW/WDT bidirectional reset ( $\overline{EA} = 0$ )

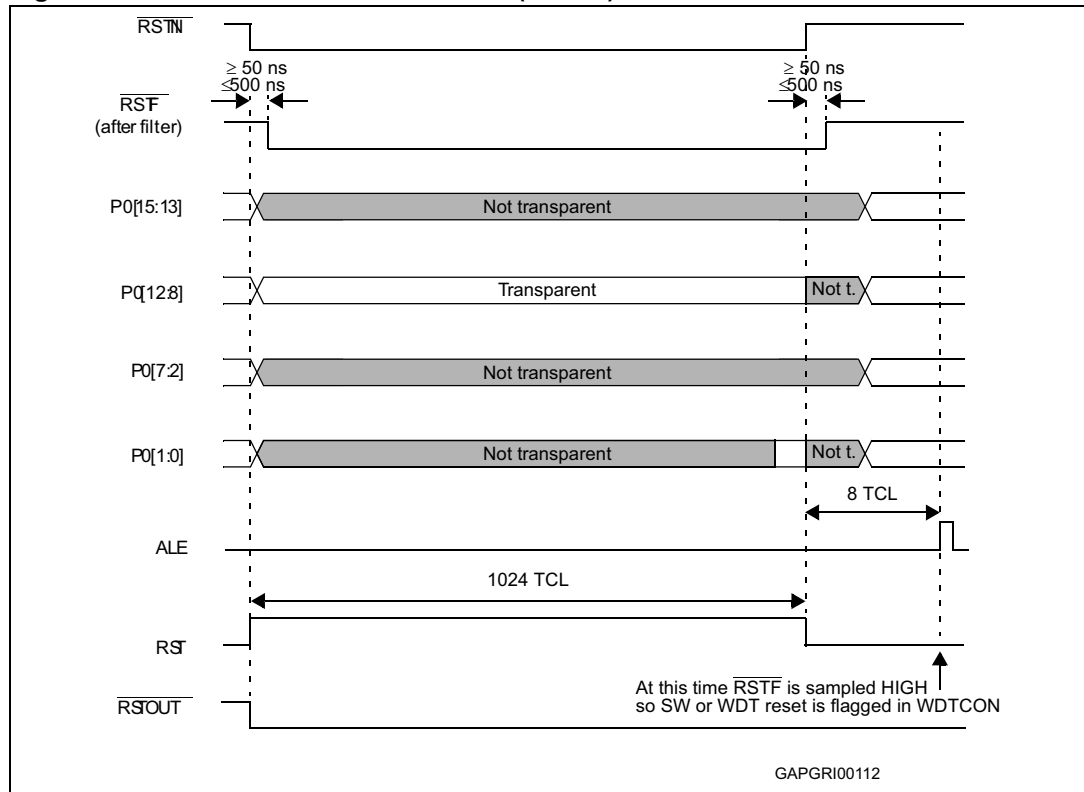
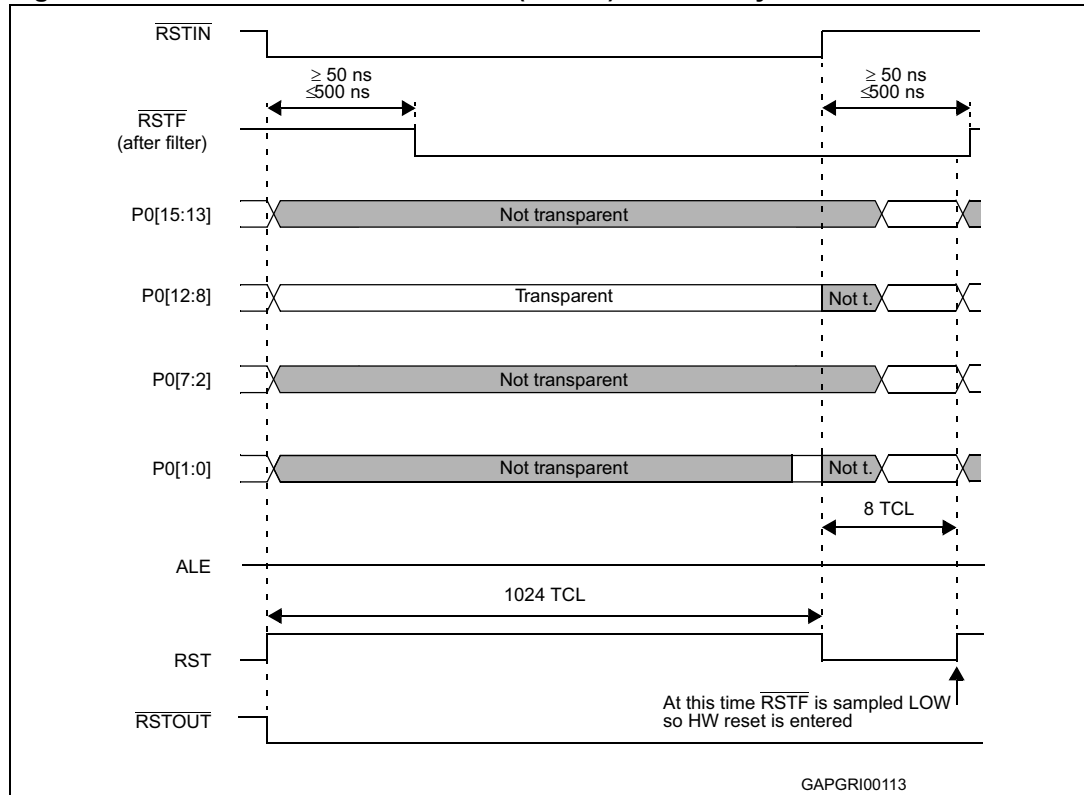

Figure 29. SW/WDT bidirectional reset ( $\overline{EA} = 0$ ) followed by a HW reset



## 20.7 Reset circuitry

Internal reset circuitry is described in [Figure 32](#). The  $\overline{\text{RSTIN}}$  pin provides an internal pull-up resistor of 50 k $\Omega$  to 250 k $\Omega$  (The minimum reset time must be calculated using the lowest value).

It also provides a programmable (BDRSTEN bit of SYSCON register) pull-down to output internal reset state signal (synchronous reset, watchdog timer reset or software reset).

This bidirectional reset function is useful in applications where external devices require a reset signal but cannot be connected to  $\overline{\text{RSTOUT}}$  pin.

This is the case of an external memory running codes before EINIT (end of initialization) instruction is executed.  $\overline{\text{RSTOUT}}$  pin is pulled high only when EINIT is executed.

The RPD pin provides an internal weak pull-down resistor which discharges external capacitor at a typical rate of 200  $\mu\text{A}$ . If bit PWDCFG of SYSCON register is set, an internal pull-up resistor is activated at the end of the reset sequence. This pull-up will charge any capacitor connected on RPD pin.

The simplest way to reset the ST10F272M is to insert a capacitor C1 between  $\overline{\text{RSTIN}}$  pin and  $V_{\text{SS}}$ , and a capacitor between RPD pin and  $V_{\text{SS}}$  (C0) with a pull-up resistor R0 between RPD pin and  $V_{\text{DD}}$ . The input  $\overline{\text{RSTIN}}$  provides an internal pull-up device equalling a resistor of 50 k $\Omega$  to 250 k $\Omega$  (the minimum reset time must be determined by the lowest value). Select C1 that produce a sufficient discharge time to permit the internal or external oscillator and / or internal PLL and the on-chip voltage regulator to stabilize.

To ensure correct power-up reset with controlled supply current consumption, specially if clock signal requires a long period of time to stabilize, an asynchronous hardware reset is required during power-up. For this reason, it is recommended to connect the external R0-C0 circuit shown in [Figure 30](#) to the RPD pin. On power-up, the logical low level on RPD pin forces an asynchronous hardware reset when  $\overline{\text{RSTIN}}$  is asserted low. The external pull-up R0 will then charge the capacitor C0. Note that an internal pull-down device on RPD pin is turned on when  $\overline{\text{RSTIN}}$  pin is low, and causes the external capacitor (C0) to begin discharging at a typical rate of 100-200  $\mu\text{A}$ . With this mechanism, after power-up reset, short low pulses applied on  $\overline{\text{RSTIN}}$  produce synchronous hardware reset. If  $\overline{\text{RSTIN}}$  is asserted longer than the time needed for C0 to be discharged by the internal pull-down device, then the device is forced in an asynchronous reset. This mechanism insures recovery from catastrophic failure.

Figure 30. Minimum external reset circuitry

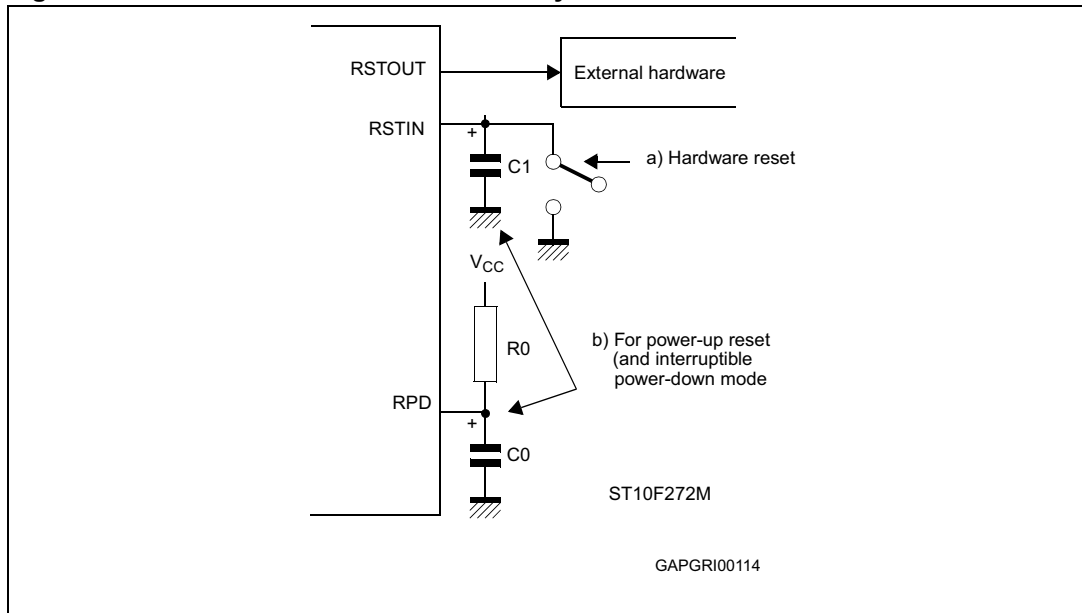

The minimum reset circuit of [Figure 30](#) is not adequate when the  $\overline{\text{RSTIN}}$  pin is driven from the ST10F272M itself during software or watchdog triggered resets, because of the capacitor C1 that will keep the voltage on  $\overline{\text{RSTIN}}$  pin above  $V_{IL}$  after the end of the internal reset sequence, and thus will trigger an asynchronous reset sequence.

[Figure 31](#) shows an example of a reset circuit. In this example, R1-C1 external circuit is only used to generate power-up or manual reset, and R0-C0 circuit on RPD is used for power-up reset and to exit from power-down mode. Diode D1 creates a wired-OR gate connection to the reset pin and may be replaced by open-collector Schmitt trigger buffer. Diode D2 provides a faster cycle time for repetitive power-on resets.

R2 is an optional pull-up for faster recovery and correct biasing of TTL open collector drivers.

Figure 31. System reset circuit

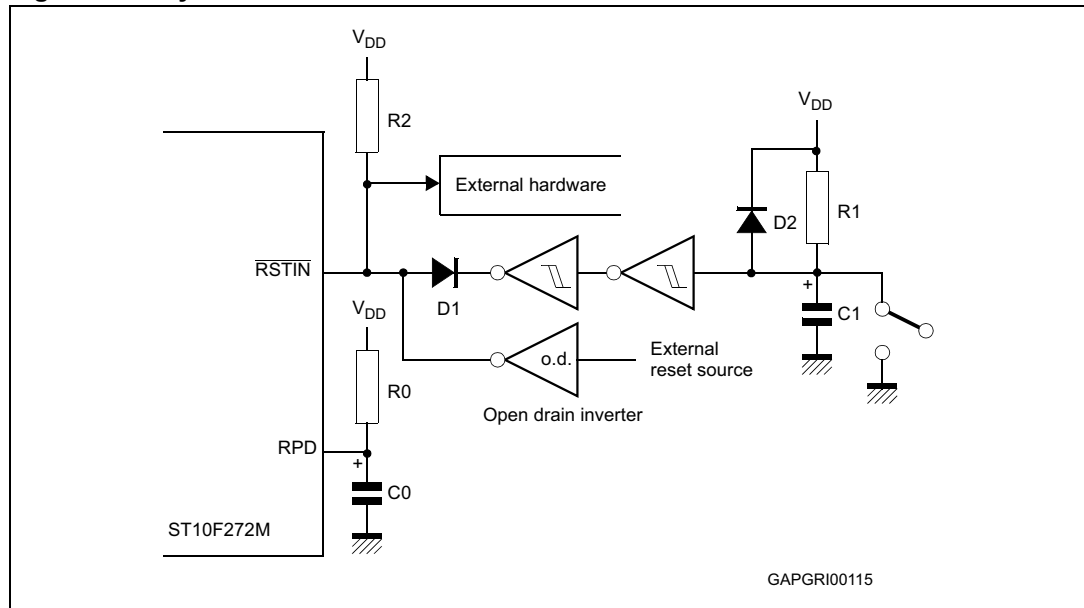
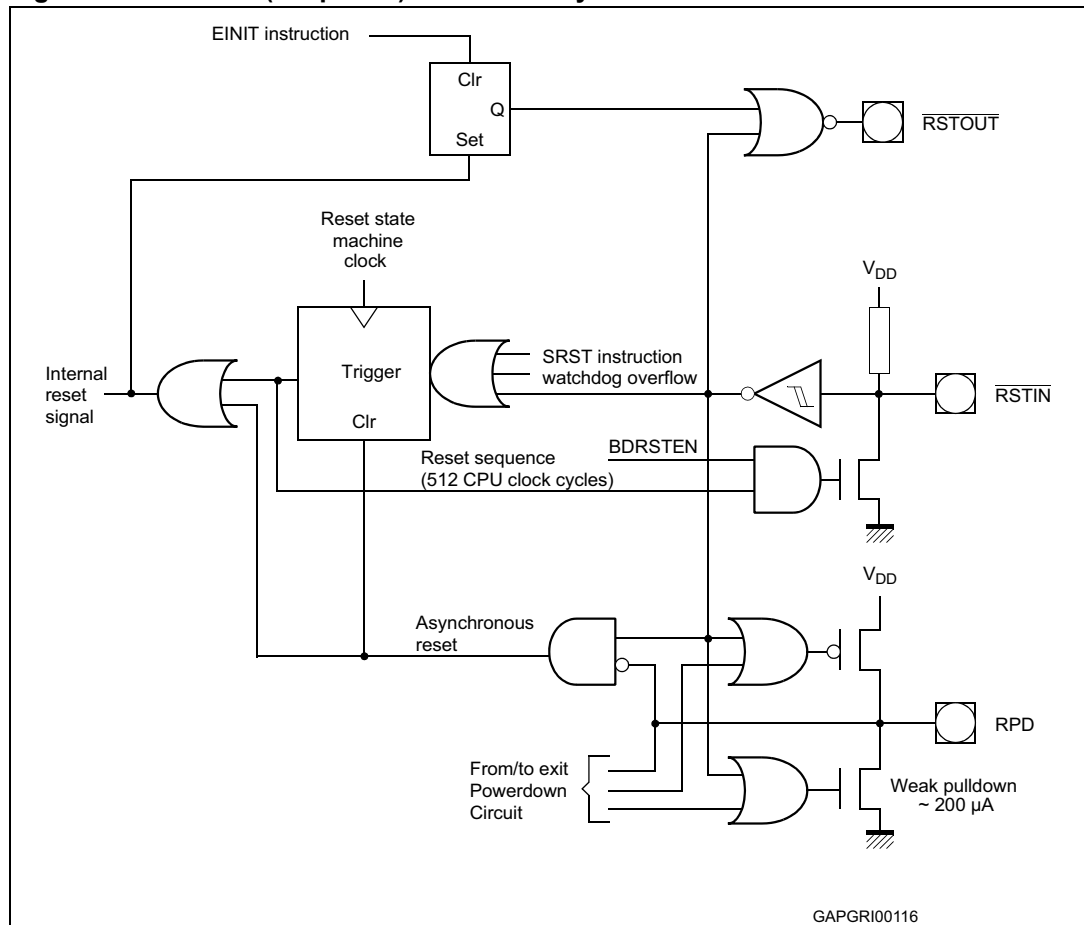

Figure 32. Internal (simplified) reset circuitry





## 20.8 Reset application examples

The next two timing diagrams (*Figure 33* and *Figure 34*) provide additional examples of bidirectional internal reset events (software and watchdog) including in particular the external capacitances charge and discharge transients (refer also to *Figure 31* for the external circuit scheme).

**Figure 33. Example of software or watchdog bidirectional reset ( $\overline{EA} = 1$ )**

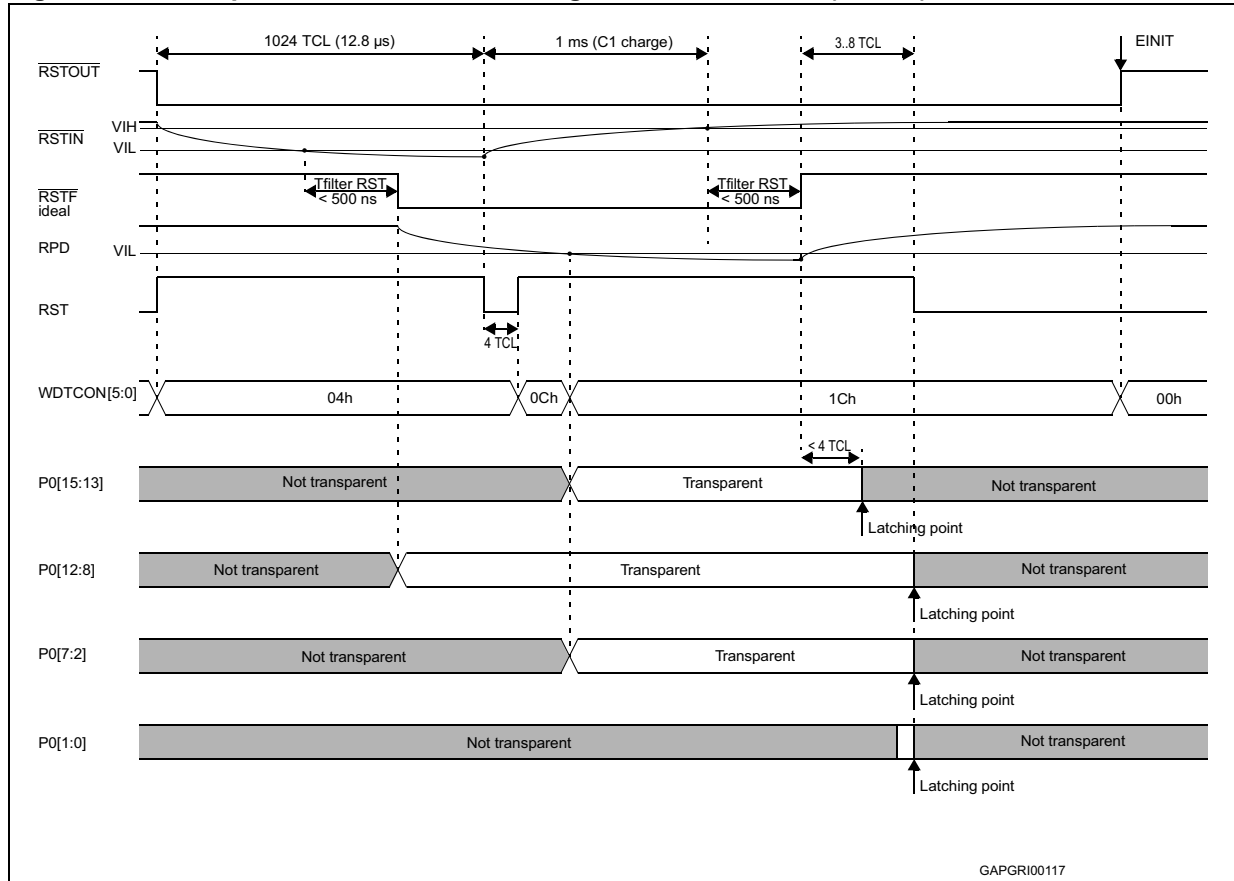
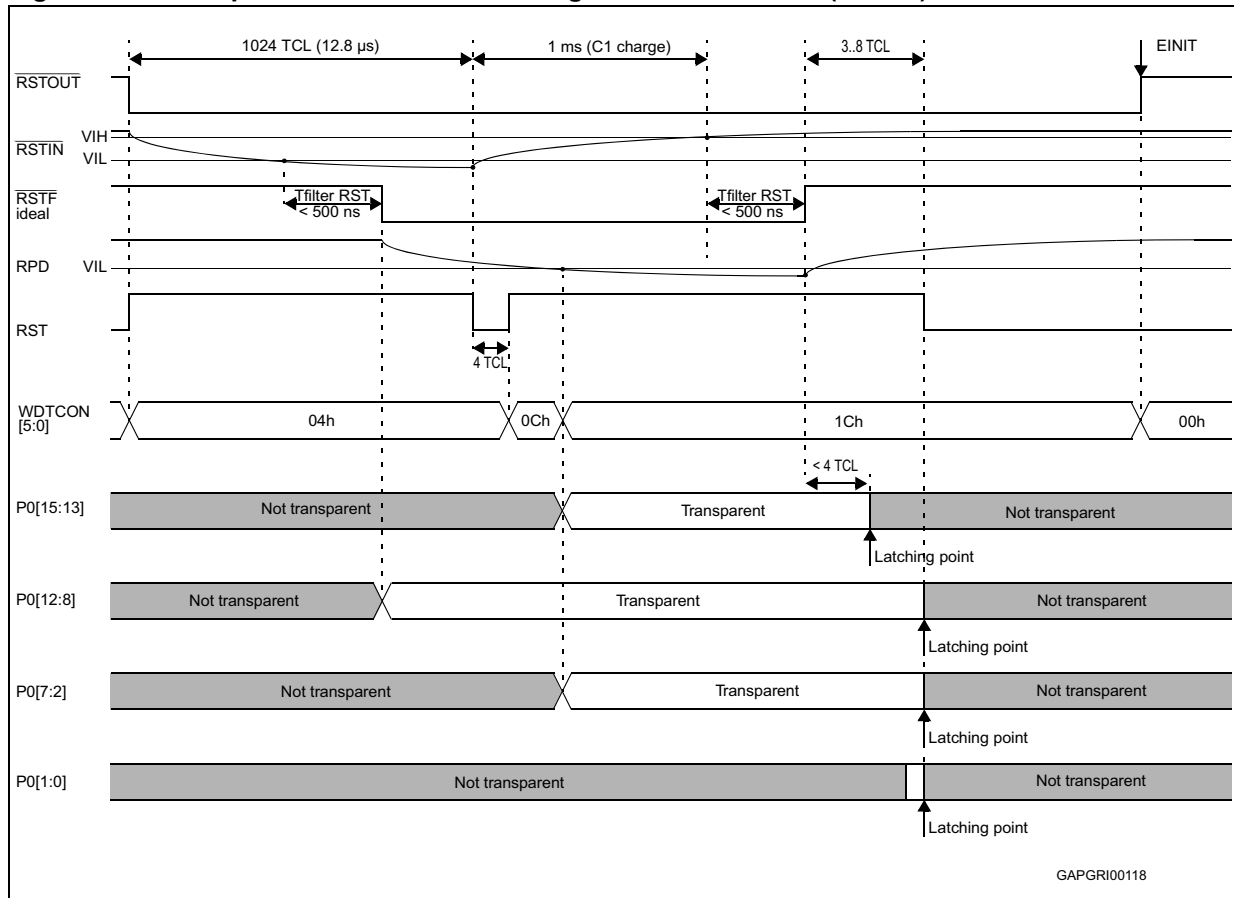

Figure 34. Example of software or watchdog bidirectional reset ( $\overline{EA} = 0$ )



## 20.9 Reset summary

The following table summarizes the different reset events.

**Table 42. Reset event**

Event	RPD	EA	Bidir	Synch. asynch.	RSTIN		WDTCN flags				
					Min	Max	PONR	LHWR	SHWR	SWR	WDTR
Power-on reset	0	0	N	Asynch.	1 ms (VREG) 1.2 ms (reson. + PLL) 10.2 ms (crystal + PLL)	-	1	1	1	1	0
	0	1	N	Asynch.	1ms (VREG)	-	1	1	1	1	0
	1	x	x	Forbidden							
	x	x	Y	-							
Hardware reset (asynchronous)	0	0	N	Asynch.	500 ns	-	0	1	1	1	0
	0	1	N	Asynch.	500 ns	-	0	1	1	1	0
	0	0	Y	Asynch.	500 ns	-	0	1	1	1	0
	0	1	Y	Asynch.	500 ns	-	0	1	1	1	0
Short hardware reset (synchronous) <sup>(1)</sup>	1	0	N	Synch.	Max (4 TCL, 500 ns)	1032 + 12 TCL + max(4 TCL, 500 ns)	0	0	1	1	0
	1	1	N	Synch.	max (4 TCL, 500 ns)	1032 + 12 TCL + max(4 TCL, 500 ns)	0	0	1	1	0
	1	0	Y	Synch.	Max (4 TCL, 500 ns)	1032 + 12 TCL + max(4 TCL, 500 ns)	0	0	1	1	0
					Activated by internal logic for 1024 TCL						
	1	1	Y	Synch.	Max (4 TCL, 500ns)	1032 + 12 TCL + max(4 TCL, 500 ns)	0	0	1	1	0
					Activated by internal logic for 1024 TCL						
Long hardware reset (synchronous)	1	0	N	Synch.	1032 + 12 TCL + Max(4 TCL, 500 ns)	-	0	1	1	1	0
	1	1	N	Synch.	1032 + 12 TCL + Max(4 TCL, 500ns)	-	0	1	1	1	0
	1	0	Y	Synch.	1032 + 12 TCL + Max(4 TCL, 500 ns)	-	0	1	1	1	0
					Activated by internal logic only for 1024 TCL						
	1	1	Y	Synch.	1032 + 12 TCL + Max(4 TCL, 500 ns)	-	0	1	1	1	0
					Activated by internal logic only for 1024 TCL						

**Table 42. Reset event (continued)**

Event	RPD	EA	Bidir	Synch. asynch.	RSTIN		WDTCN flags				
					Min	Max	PONR	LHWR	SHWR	SWR	WDTR
Software reset <sup>(2)</sup>	x	0	N	Synch.	Not activated		0	0	0	1	0
	x	0	N	Synch.	Not activated		0	0	0	1	0
	0	1	Y	Synch.	Not activated		0	0	0	1	0
	1	1	Y	Synch.	Activated by internal logic for 1024 TCL		0	0	0	1	0
Watchdog reset <sup>(2)</sup>	x	0	N	Synch.	Not activated		0	0	0	1	1
	x	0	N	Synch.	Not activated		0	0	0	1	1
	0	1	Y	Synch.	Not activated		0	0	0	1	1
	1	1	Y	Synch.	Activated by internal logic for 1024 TCL		0	0	0	1	1

1. It can degenerate into a long hardware reset and consequently differently flagged (see [Section 20.3](#) for details).
2. When bidirectional is active (and with RPD = 0), it can be followed by a short hardware reset and consequently differently flagged (see [Section 20.6](#) for details).

The start-up configurations and some system features are selected on reset sequences as described in [Table 43](#) and [Figure 35](#).

[Table 43](#) describes the system configuration latched on port0 in the six different reset modes. [Figure 35](#) summarizes the state of bits of PORT0 latched in RPOH, SYSCON, BUSCON0 registers.

**Table 43. PORT0 latched configuration for the different reset events**

Sample event	Port0															
	Clock options			Segment address lines		Chip selects		WR configuration	Bus type		Reserved	BSL	Reserved	Reserved	Adapt mode	Emu mode
	P0H.7	P0H.6	P0H.5	P0H.4	P0H.3	P0H.2	P0H.1	P0H.0	P0L.7	P0L.6	P0L.5	P0L.4	P0L.3	P0L.2	P0L.1	P0L.0
Software reset	-	-	-	X	X	X	X	X	X	X	-	-	-	-	-	-
Watchdog reset	-	-	-	X	X	X	X	X	X	X	-	-	-	-	-	-
Synchronous short hardware reset	-	-	-	X	X	X	X	X	X	X	X	X	X	X	X	X
Synchronous long hardware reset	X	X	X	X	X	X	X	X	X	X	X	X	X	X	X	X
Asynchronous hardware reset	X	X	X	X	X	X	X	X	X	X	X	X	X	X	X	X
Asynchronous power-on reset	X	X	X	X	X	X	X	X	X	X	X	X	X	X	X	X

Figure 35. Port0 bits latched into the different registers after reset

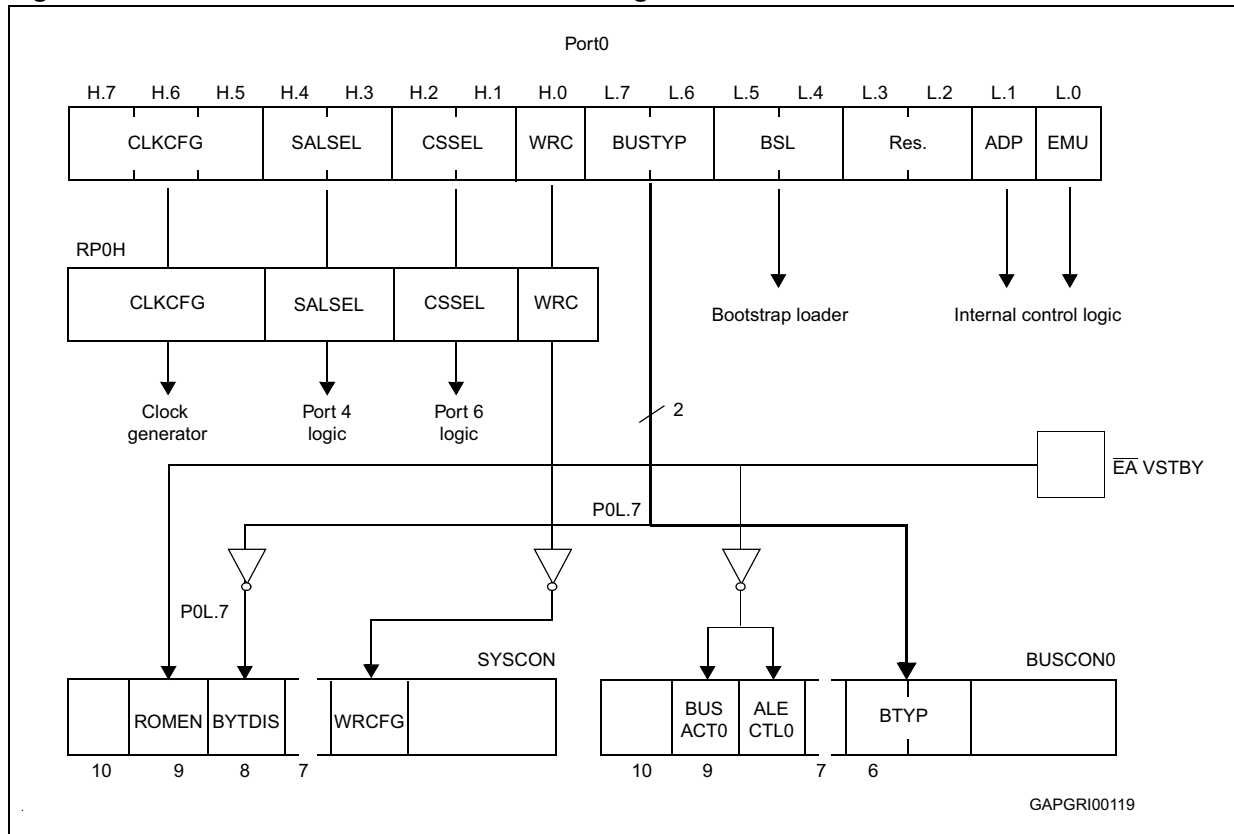

## 21 Power reduction modes

Three different power reduction modes with different levels of power reduction have been implemented in the ST10F272M. In idle mode only CPU is stopped, while peripheral still operates. In power-down mode both CPU and peripherals are stopped. In stand-by mode the main power supply ( $V_{DD}$ ) can be turned off while a portion of the internal RAM remains powered via  $V_{STBY}$  dedicated power pin.

Idle and power-down modes are software activated by a protected instruction and are terminated in different ways as described in the following sections.

Stand-by mode is entered simply removing  $V_{DD}$ , holding the MCU under reset state.

*Note:* All external bus actions are completed before idle or power-down mode is entered. However, idle or power-down mode is **not** entered if *READY* is enabled, but has not been activated (driven low for negative polarity, or driven high for positive polarity) during the last bus access.

### 21.1 Idle mode

Idle mode is entered by running IDLE protected instruction. The CPU operation is stopped and the peripherals still run.

Idle mode is terminated by any interrupt request. Whatever the interrupt is serviced or not, the instruction following the IDLE instruction will be executed after return from interrupt (RETI) instruction, then the CPU resumes the normal program.

### 21.2 Power-down mode

Power-down mode starts by running PWRDN protected instruction. Internal clock is stopped, all MCU parts are on hold including the watchdog timer. The only exception could be the real-time clock if opportunely programmed and one of the two oscillator circuits as a consequence (either the main or the 32 kHz on-chip oscillator).

When real-time clock module is used, when the device is in power-down mode a reference clock is needed. In this case, two possible configurations may be selected by the user application according to the desired level of power reduction:

- A 32 kHz crystal is connected to the on-chip low-power oscillator (pins XTAL3 / XTAL4) and running. In this case the main oscillator is stopped when power-down mode is entered, while the real-time clock continue counting using 32 kHz clock signal as reference. The presence of a running low-power oscillator is detected after the power-on: this clock is immediately assumed (if present, or as soon as it is detected) as reference for the real-time clock counter and it will be maintained forever (unless specifically disabled via software).
- Only the main oscillator is running (XTAL1 / XTAL2 pins). In this case the main oscillator is not stopped when power-down is entered, and the real-time clock continue counting using the main oscillator clock signal as reference.

There are two different operating power-down modes: protected mode and interruptible mode.

Before entering power-down mode (by executing the instruction PWRDN), bit VREGOFF in XMISC register must be set.

*Note: Leaving the main voltage regulator active during power-down may lead to unexpected behavior (example: CPU wake-up) and power consumption higher than what is specified.*

### 21.2.1 Protected power-down mode

This mode is selected when PWDCFG (bit 5) of SYSCON register is cleared. The protected power-down mode is only activated if the  $\overline{\text{NMI}}$  pin is pulled low when executing PWRDN instruction (this means that the PWRD instruction belongs to the  $\overline{\text{NMI}}$  software routine). This mode is only deactivated with an external hardware reset on  $\overline{\text{RSTIN}}$  pin.

### 21.2.2 Interruptible power-down mode

This mode is selected when PWDCFG (bit 5) of SYSCON register is set.

The interruptible power-down mode is only activated if all the enabled fast external interrupt pins are in their inactive level.

This mode is deactivated with an external reset applied to  $\overline{\text{RSTIN}}$  pin or with an interrupt request applied to one of the fast external interrupt pins, or with an interrupt generated by the real-time clock, or with an interrupt generated by the activity on CAN's and I<sup>2</sup>C module interfaces. To allow the internal PLL and clock to stabilize, the  $\overline{\text{RSTIN}}$  pin must be held low according the recommendations described in [Chapter 20: System reset on page 77](#).

An external RC circuit must be connected to RPD pin, as shown in the [Figure 36](#).

**Figure 36. External RC circuitry on RPD pin**

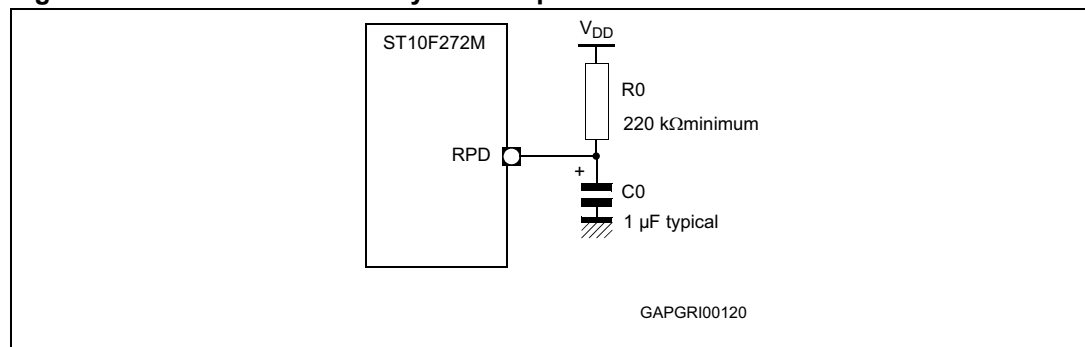

To exit power-down mode with an external interrupt, an EXxIN (x = 7...0) pin has to be asserted for at least 40 ns.

## 21.3 Stand-by mode

In stand-by mode, it is possible to turn off the main V<sub>DD</sub> provided that V<sub>STBY</sub> is available through the dedicated pin of the ST10F272M.

To enter stand-by mode it is mandatory to held the device under reset: once the device is under reset, the RAM is disabled (see XRAM2EN bit of XPERCON register), and its digital interface is frozen in order to avoid any kind of data corruption.

A dedicated embedded low-power voltage regulator is implemented to generate the internal low voltage supply (about 1.65 V in stand-by mode) to bias all those circuits that shall

remain active: the portion of XRAM (16 Kbytes for ST10F272M), the RTC counters and 32 kHz on-chip oscillator amplifier.

In normal running mode (that is when main  $V_{DD}$  is on) the  $V_{STBY}$  pin can be tied to  $V_{SS}$  during reset to exercise the  $\overline{EA}$  functionality associated with the same pin: the voltage supply for the circuitries which are usually biased with  $V_{STBY}$  (see in particular the 32 kHz oscillator used in conjunction with real-time clock module), is granted by the active main  $V_{DD}$ .

It must be noted that stand-by mode can generate problems associated with the usage of different power supplies in CMOS systems; particular attention must be paid when the ST10F272M I/O lines are interfaced with other external CMOS integrated circuits: if  $V_{DD}$  of ST10F272M becomes (for example, in stand-by mode) lower than the output level forced by the I/O lines of these external integrated circuits, the ST10F272M could be directly powered through the inherent diode existing on ST10F272M output driver circuitry. The same is valid for ST10F272M interfaced to active/inactive communication buses during stand-by mode: current injection can be generated through the inherent diode.

Furthermore, the sequence of turning on/off of the different voltage could be critical for the system (not only for the ST10F272M device). The device stand-by mode current ( $I_{STBY}$ ) may vary while  $V_{DD}$  to  $V_{STBY}$  (and vice versa) transition occurs: some current flows between  $V_{DD}$  and  $V_{STBY}$  pins. System noise on both  $V_{DD}$  and  $V_{STBY}$  can contribute to increase this phenomenon.

### 21.3.1 Entering stand-by mode

As already stated, to enter stand-by mode the XRAM2EN bit in the XPERCON register must be cleared: This allows the RAM interface to be frozen immediately, avoiding any data corruption. As a consequence of a reset event, the RAM power supply is switched to the internal low-voltage supply  $V_{18SB}$  (derived from  $V_{STBY}$  through the low-power voltage regulator). The RAM interface remains frozen until the bit XRAM2EN is set again by software initialization routine (at next exit from main  $V_{DD}$  power-on reset sequence).

Since  $V_{18}$  is falling down (as a consequence of  $V_{DD}$  turning off), it can happen that the XRAM2EN bit is no longer able to guarantee its content (logic "0"), being the XPERCON Register powered by internal  $V_{18}$ . This does not generate any problem, because the stand-by mode switching dedicated circuit continues to confirm the RAM interface freezing, irrespective the XRAM2EN bit content; XRAM2EN bit status is considered again when internal  $V_{18}$  comes back over internal stand-by reference  $V_{18SB}$ .

If internal  $V_{18}$  becomes lower than internal stand-by reference ( $V_{18SB}$ ) of about 0.3 to 0.45V with bit XRAM2EN set, the RAM supply switching circuit is not active: in case of a temporary drop on internal  $V_{18}$  voltage versus internal  $V_{18SB}$  during normal code execution, no spurious stand-by mode switching can occur (the RAM is not frozen and can still be accessed).

The ST10F272M core module, generating the RAM control signals, is powered by internal  $V_{18}$  supply; during turning off transient these control signals follow the  $V_{18}$ , while RAM is switched to  $V_{18SB}$  internal reference. It could happen that a high level of RAM write strobe from ST10F272M core (active low signal) is low enough to be recognized as a logic "0" by the RAM interface (due to  $V_{18}$  lower than  $V_{18SB}$ ): The bus status could contain a valid address for the RAM and an unwanted data corruption could occur. For this reason, an extra interface, powered by the switched supply, is used to prevent the RAM from this kind of potential corruption mechanism.



---

**Warning:** During power-off phase, it is important that the external hardware maintains a stable ground level on RSTIN pin, without any glitch, in order to avoid spurious exiting from reset status with unstable power supply.

---

### 21.3.2 Exiting stand-by mode

After the system has entered the stand-by mode, the procedure to exit this mode consists of a standard power-on sequence, with the only difference that the RAM is already powered through  $V_{18SB}$  internal reference (derived from  $V_{STBY}$  pin external voltage).

It is recommended to held the device under reset ( $\overline{RSTIN}$  pin forced low) until external  $V_{DD}$  voltage pin is stable. Even though, at the very beginning of the power-on phase, the device is maintained under reset by the internal low voltage detector circuit (implemented inside the main voltage regulator) till the internal  $V_{18}$  becomes higher than about 1.0 V, there is no guaranty that the device stays under reset status if  $\overline{RSTIN}$  is at high level during power ramp up. So, it is important the external hardware is able to guarantee a stable ground level on  $\overline{RSTIN}$  along the power-on phase, without any temporary glitch.

The external hardware is responsible for driving the  $\overline{RSTIN}$  pin low until the  $V_{DD}$  is stable, even though the internal LVD is active.

Once the internal reset signal goes low, the RAM (still frozen) power supply is switched to the main  $V_{18}$ .

At this time, everything becomes stable, and the execution of the initialization routines can start: XRAM2EN bit can be set, enabling the RAM.

### 21.3.3 Real-time clock and stand-by mode

When stand-by mode is entered (turning off the main supply  $V_{DD}$ ), the real-time clock counting can be maintained running in case the on-chip 32 kHz oscillator is used to provide the reference to the counter. This is not possible if the main oscillator is used as reference for the counter: Being the main oscillator powered by  $V_{DD}$ , once this is switched off, the oscillator is stopped.

### 21.3.4 Power reduction modes summary

The different power reduction modes are summarized in the following [Table 44](#).

**Table 44. Power reduction modes summary**

Mode	V <sub>DD</sub>	V <sub>STBY</sub>	CPU	Peripherals	RTC	Main OSC	32 kHz OSC	STBY XRAM	XRAM
Idle	On	On	Off	On	Off	Run	Off	Biased	Biased
	On	On	Off	On	On	Run	On	Biased	Biased
Power-down	On	On	Off	Off	Off	Off	Off	Biased	Biased
	On	On	Off	Off	On	On	Off	Biased	Biased
	On	On	Off	Off	On	Off	On	Biased	Biased
Stand-by	Off	On	Off	Off	Off	Off	Off	Biased	Off
	Off	On	Off	Off	On	Off	On	Biased	Off

## 22 Programmable output clock divider

A specific register mapped on the XBUS can be used to choose the division factor on the CLKOUT signal (P3.15). This register is mapped on X-miscellaneous memory address range.

When CLKOUT function is enabled by setting bit CLKEN of register SYSCON, by default the CPU clock is output on P3.15. Setting bit XMISCEN of register XPERCON and bit XPEN of register SYSCON, it is possible to program the clock prescaling factor. In this way on P3.15 a prescaled value of the CPU clock can be output.

When CLKOUT function is not enabled (bit CLKEN of register SYSCON cleared), P3.15 does not output any clock signal, even though XCLKOUTDIV register is programmed.

## 23 Register set

This section summarizes all registers implemented in the ST10F272M, ordered by name.

### 23.1 Special function registers

*Table 45* lists all SFRs which are implemented in the ST10F272M in alphabetical order. Bit-addressable SFRs are marked with the letter 'b' in the column 'Name'.

SFRs within the extended sfr-space (ESFRs) are marked with the letter 'E' in the 'Physical address' column.

**Table 45. List of special function registers**

Name	Physical address	8-bit address	Description	Reset value
ADCICb	FF98h	CCh	A/D converter end of conversion interrupt control register	--00h
ADCONb	FFA0h	D0h	A/D converter control register	0000h
ADDAT	FEA0h	50h	A/D converter result register	0000h
ADDAT2	F0A0h <b>E</b>	50h	A/D converter 2 result register	0000h
ADDRSEL1	FE18h	0Ch	Address select register 1	0000h
ADDRSEL2	FE1Ah	0Dh	Address select register 2	0000h
ADDRSEL3	FE1Ch	0Eh	Address select register 3	0000h
ADDRSEL4	FE1Eh	0Fh	Address select register 4	0000h
ADEICb	FF9Ah	CDh	A/D converter overrun error interrupt control register	--00h
BUSCON0b	FF0Ch	86h	Bus configuration register 0	0xx0h
BUSCON1b	FF14h	8Ah	Bus configuration register 1	0000h
BUSCON2b	FF16h	8Bh	Bus configuration register 2	0000h
BUSCON3b	FF18h	8Ch	Bus configuration register 3	0000h
BUSCON4b	FF1Ah	8Dh	Bus configuration register 4	0000h
CAPREL	FE4Ah	25h	GPT2 capture/reload register	0000h
CC0	FE80h	40h	CAPCOM register 0	0000h
CC0ICb	FF78h	BCh	CAPCOM register 0 interrupt control register	--00h
CC1	FE82h	41h	CAPCOM register 1	0000h
CC1ICb	FF7Ah	BDh	CAPCOM register 1 interrupt control register	--00h
CC2	FE84h	42h	CAPCOM register 2	0000h
CC2ICb	FF7Ch	BEh	CAPCOM register 2 interrupt control register	--00h
CC3	FE86h	43h	CAPCOM register 3	0000h
CC3ICb	FF7Eh	BFh	CAPCOM register 3 interrupt control register	--00h
CC4	FE88h	44h	CAPCOM register 4	0000h

Table 45. List of special function registers (continued)

Name	Physical address	8-bit address	Description	Reset value
CC4ICb	FF80h	C0h	CAPCOM register 4 interrupt control register	--00h
CC5	FE8Ah	45h	CAPCOM register 5	0000h
CC5ICb	FF82h	C1h	CAPCOM register 5 interrupt control register	--00h
CC6	FE8Ch	46h	CAPCOM register 6	0000h
CC6ICb	FF84h	C2h	CAPCOM register 6 interrupt control register	--00h
CC7	FE8Eh	47h	CAPCOM register 7	0000h
CC7ICb	FF86h	C3h	CAPCOM register 7 interrupt control register	--00h
CC8	FE90h	48h	CAPCOM register 8	0000h
CC8ICb	FF88h	C4h	CAPCOM register 8 interrupt control register	--00h
CC9	FE92h	49h	CAPCOM register 9	0000h
CC9ICb	FF8Ah	C5h	CAPCOM register 9 interrupt control register	--00h
CC10	FE94h	4Ah	CAPCOM register 10	0000h
CC10ICb	FF8Ch	C6h	CAPCOM register 10 interrupt control register	--00h
CC11	FE96h	4Bh	CAPCOM register 11	0000h
CC11ICb	FF8Eh	C7h	CAPCOM register 11 interrupt control register	--00h
CC12	FE98h	4Ch	CAPCOM register 12	0000h
CC12ICb	FF90h	C8h	CAPCOM register 12 interrupt control register	--00h
CC13	FE9Ah	4Dh	CAPCOM register 13	0000h
CC13ICb	FF92h	C9h	CAPCOM register 13 interrupt control register	--00h
CC14	FE9Ch	4Eh	CAPCOM register 14	0000h
CC14ICb	FF94h	CAh	CAPCOM register 14 interrupt control register	--00h
CC15	FE9Eh	4Fh	CAPCOM register 15	0000h
CC15ICb	FF96h	CBh	CAPCOM register 15 interrupt control register	--00h
CC16	FE60h	30h	CAPCOM register 16	0000h
CC16ICb	F160hE	B0h	CAPCOM register 16 interrupt control register	--00h
CC17	FE62h	31h	CAPCOM register 17	0000h
CC17ICb	F162hE	B1h	CAPCOM register 17 interrupt control register	--00h
CC18	FE64h	32h	CAPCOM register 18	0000h
CC18ICb	F164hE	B2h	CAPCOM register 18 interrupt control register	--00h
CC19	FE66h	33h	CAPCOM register 19	0000h
CC19ICb	F166hE	B3h	CAPCOM register 19 interrupt control register	--00h
CC20	FE68h	34h	CAPCOM register 20	0000h
CC20ICb	F168hE	B4h	CAPCOM register 20 interrupt control register	--00h
CC21	FE6Ah	35h	CAPCOM register 21	0000h

Table 45. List of special function registers (continued)

Name	Physical address	8-bit address	Description	Reset value
CC21ICb	F16AhE	B5h	CAPCOM register 21 interrupt control register	-- 00h
CC22	FE6Ch	36h	CAPCOM register 22	0000h
CC22ICb	F16ChE	B6h	CAPCOM register 22 interrupt control register	-- 00h
CC23	FE6Eh	37h	CAPCOM register 23	0000h
CC23ICb	F16EhE	B7h	CAPCOM register 23 interrupt control register	-- 00h
CC24	FE70h	38h	CAPCOM register 24	0000h
CC24ICb	F170hE	B8h	CAPCOM register 24 interrupt control register	-- 00h
CC25	FE72h	39h	CAPCOM register 25	0000h
CC25ICb	F172hE	B9h	CAPCOM register 25 interrupt control register	-- 00h
CC26	FE74h	3Ah	CAPCOM register 26	0000h
CC26ICb	F174hE	BAh	CAPCOM register 26 interrupt control register	-- 00h
CC27	FE76h	3Bh	CAPCOM register 27	0000h
CC27ICb	F176hE	BBh	CAPCOM register 27 interrupt control register	-- 00h
CC28	FE78h	3Ch	CAPCOM register 28	0000h
CC28ICb	F178hE	BCh	CAPCOM register 28 interrupt control register	-- 00h
CC29	FE7Ah	3Dh	CAPCOM register 29	0000h
CC29ICb	F184hE	C2h	CAPCOM register 29 interrupt control register	-- 00h
CC30	FE7Ch	3Eh	CAPCOM register 30	0000h
CC30ICb	F18ChE	C6h	CAPCOM register 30 interrupt control register	-- 00h
CC31	FE7Eh	3Fh	CAPCOM register 31	0000h
CC31ICb	F194hE	CAh	CAPCOM register 31 interrupt control register	-- 00h
CCM0b	FF52h	A9h	CAPCOM mode control register 0	0000h
CCM1b	FF54h	AAh	CAPCOM mode control register 1	0000h
CCM2b	FF56h	ABh	CAPCOM mode control register 2	0000h
CCM3b	FF58h	ACh	CAPCOM mode control register 3	0000h
CCM4b	FF22h	91h	CAPCOM mode control register 4	0000h
CCM5b	FF24h	92h	CAPCOM mode control register 5	0000h
CCM6b	FF26h	93h	CAPCOM mode control register 6	0000h
CCM7b	FF28h	94h	CAPCOM mode control register 7	0000h
CP	FE10h	08h	CPU context pointer register	FC00h
CRICb	FF6Ah	B5h	GPT2 CAPREL interrupt control register	-- 00h
CSP	FE08h	04h	CPU code segment pointer register (read only)	0000h
DP0Lb	F100hE	80h	P0L direction control register	-- 00h
DP0Hb	F102hE	81h	P0h direction control register	-- 00h

Table 45. List of special function registers (continued)

Name	Physical address	8-bit address	Description	Reset value
DP1Lb	F104hE	82h	P1L direction control register	-- 00h
DP1Hb	F106hE	83h	P1h direction control register	-- 00h
DP2 b	FFC2h	E1h	Port 2 direction control register	0000h
DP3 b	FFC6h	E3h	Port 3 direction control register	0000h
DP4 b	FFCAh	E5h	Port 4 direction control register	-- 00h
DP6 b	FFCEh	E7h	Port 6 direction control register	-- 00h
DP7 b	FFD2h	E9h	Port 7 direction control register	-- 00h
DP8 b	FFD6h	EBh	Port 8 direction control register	-- 00h
DPP0	FE00h	00h	CPU data page pointer 0 register (10-bit)	0000h
DPP1	FE02h	01h	CPU data page pointer 1 register (10-bit)	0001h
DPP2	FE04h	02h	CPU data page pointer 2 register (10-bit)	0002h
DPP3	FE06h	03h	CPU data page pointer 3 register (10-bit)	0003h
EMUCON	FE0Ah	05h	Emulation control register	-- XXh
EXICONb	F1C0hE	E0h	External interrupt control register	0000h
EXISELb	F1DAhE	EDh	External interrupt source selection register	0000h
IDCHIP	F07ChE	3Eh	Device identifier register (n is the device revision)	110nh
IDMANUF	F07EhE	3Fh	Manufacturer identifier register	0403h
IDMEM	F07AhE	3Dh	On-chip memory identifier register	2040h
IDPROG	F078hE	3Ch	Programming voltage identifier register	0040h
IDX0b	FF08h	84h	MAC unit address pointer 0	0000h
IDX1b	FF0Ah	85h	MAC unit address pointer 1	0000h
MAH	FE5Eh	2Fh	MAC unit accumulator - high word	0000h
MAL	FE5Ch	2Eh	MAC unit accumulator - low word	0000h
MCWb	FFDCh	EEh	MAC unit control word	0000h
MDCb	FF0Eh	87h	CPU multiply divide control register	0000h
MDH	FE0Ch	06h	CPU multiply divide register – high word	0000h
MDL	FE0Eh	07h	CPU multiply divide register – low word	0000h
MRWb	FFDAh	EDh	MAC unit repeat word	0000h
MSWb	FFDEh	EFh	MAC unit status word	0200h
ODP2b	F1C2hE	E1h	Port 2 open drain control register	0000h
ODP3b	F1C6hE	E3h	Port 3 open drain control register	0000h
ODP4b	F1CAhE	E5h	Port 4 open drain control register	-- 00h
ODP6b	F1CEhE	E7h	Port 6 open drain control register	-- 00h
ODP7b	F1D2hE	E9h	Port 7 open drain control register	-- 00h

Table 45. List of special function registers (continued)

Name	Physical address	8-bit address	Description	Reset value
ODP8b	F1D6hE	EBh	Port 8 open drain control register	-- 00h
ONESb	FF1Eh	8Fh	Constant value 1's register (read only)	FFFFh
P0L b	FF00h	80h	PORT0 low register (lower half of PORT0)	-- 00h
P0H b	FF02h	81h	PORT0 high register (upper half of PORT0)	-- 00h
P1L b	FF04h	82h	PORT1 low register (lower half of PORT1)	-- 00h
P1H b	FF06h	83h	PORT1 high register (upper half of PORT1)	-- 00h
P2 b	FFC0h	E0h	Port 2 register	0000h
P3 b	FFC4h	E2h	Port 3 register	0000h
P4 b	FFC8h	E4h	Port 4 register (8-bit)	-- 00h
P5 b	FFA2h	D1h	Port 5 register (read only)	XXXXh
P6 b	FFCCh	E6h	Port 6 register (8-bit)	-- 00h
P7 b	FFD0h	E8h	Port 7 register (8-bit)	-- 00h
P8 b	FFD4h	EAh	Port 8 register (8-bit)	-- 00h
P5DIDISb	FFA4h	D2h	Port 5 digital disable register	0000h
PECC0	FEC0h	60h	PEC channel 0 control register	0000h
PECC1	FEC2h	61h	PEC channel 1 control register	0000h
PECC2	FEC4h	62h	PEC channel 2 control register	0000h
PECC3	FEC6h	63h	PEC channel 3 control register	0000h
PECC4	FEC8h	64h	PEC channel 4 control register	0000h
PECC5	FECAh	65h	PEC channel 5 control register	0000h
PECC6	FECCh	66h	PEC channel 6 control register	0000h
PECC7	FECEh	67h	PEC channel 7 control register	0000h
PICONb	F1C4hE	E2h	Port input threshold control register	-- 00h
PP0	F038hE	1Ch	PWM module period register 0	0000h
PP1	F03AhE	1Dh	PWM module period register 1	0000h
PP2	F03ChE	1Eh	PWM module period register 2	0000h
PP3	F03EhE	1Fh	PWM module period register 3	0000h
PSWb	FF10h	88h	CPU program status word	0000h
PT0	F030hE	18h	PWM module up/down counter 0	0000h
PT1	F032hE	19h	PWM module up/down counter 1	0000h
PT2	F034hE	1Ah	PWM module up/down counter 2	0000h
PT3	F036hE	1Bh	PWM module up/down counter 3	0000h
PW0	FE30h	18h	PWM module pulse width register 0	0000h
PW1	FE32h	19h	PWM module pulse width register 1	0000h



Table 45. List of special function registers (continued)

Name	Physical address	8-bit address	Description	Reset value
PW2	FE34h	1Ah	PWM module pulse width register 2	0000h
PW3	FE36h	1Bh	PWM module pulse width register 3	0000h
PWMCON0b	FF30h	98h	PWM module control register 0	0000h
PWMCON1b	FF32h	99h	PWM module control register 1	0000h
PWMICb	F17EhE	BFh	PWM module interrupt control register	--00h
QR0	F004hE	02h	MAC unit offset register r0	0000h
QR1	F006hE	03h	MAC unit offset register R1	0000h
QX0	F000hE	00h	MAC unit offset register X0	0000h
QX1	F002hE	01h	MAC unit offset register X1	0000h
RP0Hb	F108hE	84h	System start-up configuration register (read only)	--XXh
S0BG	FEB4h	5Ah	Serial channel 0 baudrate generator reload register	0000h
S0CONb	FFB0h	D8h	Serial channel 0 control register	0000h
S0EICb	FF70h	B8h	Serial channel 0 error interrupt control register	--00h
S0RBUF	FEB2h	59h	Serial channel 0 receive buffer register (read only)	--XXh
S0RICb	FF6Eh	B7h	Serial channel 0 receive interrupt control register	--00h
S0TBICb	F19ChE	CEh	Serial channel 0 transmit buffer interrupt control reg.	--00h
S0TBUF	FEB0h	58h	Serial channel 0 transmit buffer register (write only)	0000h
S0TICb	FF6Ch	B6h	Serial channel 0 transmit interrupt control register	--00h
SP	FE12h	09h	CPU system stack pointer register	FC00h
SSCBR	F0B4hE	5Ah	SSC baudrate register	0000h
SSCCONb	FFB2h	D9h	SSC control register	0000h
SSCEICb	FF76h	BBh	SSC error interrupt control register	--00h
SSCRB	F0B2hE	59h	SSC receive buffer (read only)	XXXXh
SSCRICb	FF74h	BAh	SSC receive interrupt control register	--00h
SSCTB	F0B0hE	58h	SSC transmit buffer (write only)	0000h
SSCTICb	FF72h	B9h	SSC transmit interrupt control register	--00h
STKOV	FE14h	0Ah	CPU stack overflow pointer register	FA00h
STKUN	FE16h	0Bh	CPU stack underflow pointer register	FC00h
SYSCONb	FF12h	89h	CPU system configuration register	0xx0h <sup>(1)</sup>
T0	FE50h	28h	CAPCOM timer 0 register	0000h
T01CONb	FF50h	A8h	CAPCOM timer 0 and timer 1 control register	0000h
T0ICb	FF9Ch	CEh	CAPCOM timer 0 interrupt control register	--00h
T0REL	FE54h	2Ah	CAPCOM timer 0 reload register	0000h
T1	FE52h	29h	CAPCOM timer 1 register	0000h

Table 45. List of special function registers (continued)

Name	Physical address	8-bit address	Description	Reset value
T1ICb	FF9Eh	CFh	CAPCOM timer 1 interrupt control register	--00h
T1REL	FE56h	2Bh	CAPCOM timer 1 reload register	0000h
T2	FE40h	20h	GPT1 timer 2 register	0000h
T2CONb	FF40h	A0h	GPT1 timer 2 control register	0000h
T2ICb	FF60h	B0h	GPT1 timer 2 interrupt control register	--00h
T3	FE42h	21h	GPT1 timer 3 register	0000h
T3CONb	FF42h	A1h	GPT1 timer 3 control register	0000h
T3ICb	FF62h	B1h	GPT1 timer 3 interrupt control register	--00h
T4	FE44h	22h	GPT1 timer 4 register	0000h
T4CONb	FF44h	A2h	GPT1 timer 4 control register	0000h
T4ICb	FF64h	B2h	GPT1 timer 4 interrupt control register	--00h
T5	FE46h	23h	GPT2 timer 5 register	0000h
T5CONb	FF46h	A3h	GPT2 timer 5 control register	0000h
T5ICb	FF66h	B3h	GPT2 timer 5 interrupt control register	--00h
T6	FE48h	24h	GPT2 timer 6 register	0000h
T6CONb	FF48h	A4h	GPT2 timer 6 control register	0000h
T6ICb	FF68h	B4h	GPT2 timer 6 interrupt control register	--00h
T7	F050hE	28h	CAPCOM timer 7 register	0000h
T78CONb	FF20h	90h	CAPCOM timer 7 and 8 control register	0000h
T7ICb	F17AhE	BDh	CAPCOM timer 7 interrupt control register	--00h
T7REL	F054hE	2Ah	CAPCOM timer 7 reload register	0000h
T8	F052hE	29h	CAPCOM timer 8 register	0000h
T8ICb	F17ChE	BEh	CAPCOM timer 8 interrupt control register	--00h
T8REL	F056hE	2Bh	CAPCOM timer 8 reload register	0000h
TFR b	FFACh	D6h	Trap flag register	0000h
WDT	FEAEh	57h	Watchdog timer register (read only)	0000h
WDTCONb	FFAEh	D7h	Watchdog timer control register	00xxh <sup>(2)</sup>
XADRS3	F01ChE	0Eh	XPER address select register 3	800Bh
XP0ICb	F186hE	C3h	See <a href="#">Section 9.1</a>	--00h <sup>(3)</sup>
XP1ICb	F18EhE	C7h	See <a href="#">Section 9.1</a>	--00h <sup>(3)</sup>
XP2ICb	F196hE	CBh	See <a href="#">Section 9.1</a>	--00h <sup>(3)</sup>
XP3ICb	F19EhE	CFh	See <a href="#">Section 9.1</a>	--00h <sup>(3)</sup>
XPERCONb	F024hE	12h	XPER configuration register	--05h
ZEROSb	FF1Ch	8Eh	Constant value 0's register (read only)	0000h

1. The system configuration is selected during reset. SYSCON reset value is 0000 0xx0 x000 0000b.
2. Reset value depends on different triggered reset event.
3. The XPnIC interrupt control registers control interrupt requests from integrated X-bus peripherals. Some software controlled interrupt requests may be generated by setting the XPnIR bits (of XPnIC register) of the unused X-peripheral nodes.

## 23.2 X-registers

The following table lists all X-bus registers which are implemented in the ST10F272M ordered by their name.

*Note: The X-Registers are not bit-addressable.*

**Table 46. List of X-bus registers**

Name	Physical address	Description	Reset value
CAN1BRPER	EF0Ch	CAN1: BRP extension register	0000h
CAN1BTR	EF06h	CAN1: Bit timing register	2301h
CAN1CR	EF00h	CAN1: CAN control register	0001h
CAN1EC	EF04h	CAN1: Error counter	0000h
CAN1IF1A1	EF18h	CAN1: IF1 arbitration 1	0000h
CAN1IF1A2	EF1Ah	CAN1: IF1 arbitration 2	0000h
CAN1IF1CM	EF12h	CAN1: IF1 command mask	0000h
CAN1IF1CR	EF10h	CAN1: IF1 command request	0001h
CAN1IF1DA1	EF1Eh	CAN1: IF1 data A 1	0000h
CAN1IF1DA2	EF20h	CAN1: IF1 data A 2	0000h
CAN1IF1DB1	EF22h	CAN1: IF1 data B 1	0000h
CAN1IF1DB2	EF24h	CAN1: IF1 data B 2	0000h
CAN1IF1M1	EF14h	CAN1: IF1 mask 1	FFFFh
CAN1IF1M2	EF16h	CAN1: IF1 mask 2	FFFFh
CAN1IF1MC	EF1Ch	CAN1: IF1 message control	0000h
CAN1IF2A1	EF48h	CAN1: IF2 arbitration 1	0000h
CAN1IF2A2	EF4Ah	CAN1: IF2 arbitration 2	0000h
CAN1IF2CM	EF42h	CAN1: IF2 command mask	0000h
CAN1IF2CR	EF40h	CAN1: IF2 command request	0001h
CAN1IF2DA1	EF4Eh	CAN1: IF2 data A 1	0000h
CAN1IF2DA2	EF50h	CAN1: IF2 data A 2	0000h
CAN1IF2DB1	EF52h	CAN1: IF2 data B 1	0000h
CAN1IF2DB2	EF54h	CAN1: IF2 data B 2	0000h
CAN1IF2M1	EF44h	CAN1: IF2 Mask 1	FFFFh
CAN1IF2M2	EF46h	CAN1: IF2 mask 2	FFFFh

Table 46. List of X-bus registers (continued)

Name	Physical address	Description	Reset value
CAN1IF2MC	EF4Ch	CAN1: IF2 message control	0000h
CAN1IP1	EFA0h	CAN1: Interrupt pending 1	0000h
CAN1IP2	EFA2h	CAN1: Interrupt pending 2	0000h
CAN1IR	EF08h	CAN1: Interrupt register	0000h
CAN1MV1	EFB0h	CAN1: Message valid 1	0000h
CAN1MV2	EFB2h	CAN1: Message valid 2	0000h
CAN1ND1	EF90h	CAN1: New data 1	0000h
CAN1ND2	EF92h	CAN1: New data 2	0000h
CAN1SR	EF02h	CAN1: Status register	0000h
CAN1TR	EF0Ah	CAN1: Test register	00x0h
CAN1TR1	EF80h	CAN1: Transmission request 1	0000h
CAN1TR2	EF82h	CAN1: Transmission request 2	0000h
CAN2BRPER	EE0Ch	CAN2: BRP extension register	0000h
CAN2BTR	EE06h	CAN2: Bit timing register	2301h
CAN2CR	EE00h	CAN2: CAN control register	0001h
CAN2EC	EE04h	CAN2: Error counter	0000h
CAN2IF1A1	EE18h	CAN2: IF1 arbitration 1	0000h
CAN2IF1A2	EE1Ah	CAN2: IF1 arbitration 2	0000h
CAN2IF1CM	EE12h	CAN2: IF1 command mask	0000h
CAN2IF1CR	EE10h	CAN2: IF1 command request	0001h
CAN2IF1DA1	EE1Eh	CAN2: IF1 data A 1	0000h
CAN2IF1DA2	EE20h	CAN2: IF1 data A 2	0000h
CAN2IF1DB1	EE22h	CAN2: IF1 data B 1	0000h
CAN2IF1DB2	EE24h	CAN2: IF1 data B 2	0000h
CAN2IF1M1	EE14h	CAN2: IF1 mask 1	FFFFh
CAN2IF1M2	EE16h	CAN2: IF1 mask 2	FFFFh
CAN2IF1MC	EE1Ch	CAN2: IF1 message control	0000h
CAN2IF2A1	EE48h	CAN2: IF2 arbitration 1	0000h
CAN2IF2A2	EE4Ah	CAN2: IF2 arbitration 2	0000h
CAN2IF2CM	EE42h	CAN2: IF2 command mask	0000h
CAN2IF2CR	EE40h	CAN2: IF2 command request	0001h
CAN2IF2DA1	EE4Eh	CAN2: IF2 data A 1	0000h
CAN2IF2DA2	EE50h	CAN2: IF2 data A 2	0000h
CAN2IF2DB1	EE52h	CAN2: IF2 data B 1	0000h
CAN2IF2DB2	EE54h	CAN2: IF2 data B 2	0000h

Table 46. List of X-bus registers (continued)

Name	Physical address	Description	Reset value
CAN2IF2M1	EE44h	CAN2: IF2 mask 1	FFFFh
CAN2IF2M2	EE46h	CAN2: IF2 mask 2	FFFFh
CAN2IF2MC	EE4Ch	CAN2: IF2 message control	0000h
CAN2IP1	EEA0h	CAN2: Interrupt pending 1	0000h
CAN2IP2	EEA2h	CAN2: Interrupt pending 2	0000h
CAN2IR	EE08h	CAN2: Interrupt register	0000h
CAN2MV1	EEB0h	CAN2: Message valid 1	0000h
CAN2MV2	EEB2h	CAN2: Message valid 2	0000h
CAN2ND1	EE90h	CAN2: New data 1	0000h
CAN2ND2	EE92h	CAN2: New data 2	0000h
CAN2SR	EE02h	CAN2: Status register	0000h
CAN2TR	EE0Ah	CAN2: Test register	00x0h
CAN2TR1	EE80h	CAN2: Transmission request 1	0000h
CAN2TR2	EE82h	CAN2: Transmission request 2	0000h
I2CCCR1	EA06h	I <sup>2</sup> C clock control register 1	0000h
I2CCCR2	EA0Eh	I <sup>2</sup> C clock control register 2	0000h
I2CCR	EA00h	I <sup>2</sup> C control register	0000h
I2CDR	EA0Ch	I <sup>2</sup> C data register	0000h
I2COAR1	EA08h	I <sup>2</sup> C own address register 1	0000h
I2COAR2	EA0Ah	I <sup>2</sup> C own address register 2	0000h
I2CSR1	EA02h	I <sup>2</sup> C status register 1	0000h
I2CSR2	EA04h	I <sup>2</sup> C status register 2	0000h
RTCAH	ED14h	RTC alarm register high byte	XXXXh
RTCAL	ED12h	RTC alarm register low byte	XXXXh
RTCCON	ED00h	RTC control register	000Xh
RTCDH	ED0Ch	RTC divider counter high byte	XXXXh
RTCDL	ED0Ah	RTC divider counter low byte	XXXXh
RTCH	ED10h	RTC programmable counter high byte	XXXXh
RTCL	ED0Eh	RTC programmable counter low byte	XXXXh
RTCPH	ED08h	RTC prescaler register high byte	XXXXh
RTCPL	ED06h	RTC prescaler register low byte	XXXXh
XCLKOUTDIV	EB02h	CLKOUT divider control register	-- 00h
XEMU0	EB76h	XBUS emulation register 0 (write only)	XXXXh
XEMU1	EB78h	XBUS emulation register 1 (write only)	XXXXh
XEMU2	EB7Ah	XBUS emulation register 2 (write only)	XXXXh

Table 46. List of X-bus registers (continued)

Name	Physical address	Description	Reset value
XEMU3	EB7Ch	X-bus emulation register 3 (write only)	XXXXh
XIR0CLR	EB14h	X-interrupt 0 clear register (write only)	0000h
XIR0SEL	EB10h	X-interrupt 0 selection register	0000h
XIR0SET	EB12h	X-interrupt 0 set register (write only)	0000h
XIR1CLR	EB24h	X-interrupt 1 clear register (write only)	0000h
XIR1SEL	EB20h	X-interrupt 1 selection register	0000h
XIR1SET	EB22h	X-interrupt 1 set register (write only)	0000h
XIR2CLR	EB34h	X-interrupt 2 clear register (write only)	0000h
XIR2SEL	EB30h	X-interrupt 2 selection register	0000h
XIR2SET	EB32h	X-interrupt 2 set register (write only)	0000h
XIR3CLR	EB44h	X-interrupt 3 clear selection register (write only)	0000h
XIR3SEL	EB40h	X-interrupt 3 selection register	0000h
XIR3SET	EB42h	X-interrupt 3 set selection register (write only)	0000h
XMISC	EB46h	X-bus miscellaneous features register	0000h
XP1DIDIS	EB36h	Port 1 digital disable register	0000h
XPEREMU	EB7Eh	XPERCON copy for emulation (write only)	XXXXh
XPICON	EB26h	Extended port input threshold control register	- - 00h
XPOLAR	EC04h	XPWM module channel polarity register	0000h
XPP0	EC20h	XPWM module period register 0	0000h
XPP1	EC22h	XPWM module period register 1	0000h
XPP2	EC24h	XPWM module period register 2	0000h
XPP3	EC26h	XPWM module period register 3	0000h
XPT0	EC10h	XPWM module up/down counter 0	0000h
XPT1	EC12h	XPWM module up/down counter 1	0000h
XPT2	EC14h	XPWM module up/down counter 2	0000h
XPT3	EC16h	XPWM module up/down counter 3	0000h
XPW0	EC30h	XPWM module pulse width register 0	0000h
XPW1	EC32h	XPWM module pulse width register 1	0000h
XPW2	EC34h	XPWM module pulse width register 2	0000h
XPW3	EC36h	XPWM module pulse width register 3	0000h
XPWMCON0	EC00h	XPWM module control register 0	0000h
XPWMCON0CLR	EC08h	XPWM module clear control reg. 0 (write only)	0000h
XPWMCON0SET	EC06h	XPWM module set control register 0 (write only)	0000h
XPWMCON1	EC02h	XPWM module control register 1	0000h
XPWMCON1CLR	EC0Ch	XPWM module clear control reg. 0 (write only)	0000h

Table 46. List of X-bus registers (continued)

Name	Physical address	Description	Reset value
XPWMCON1SET	EC0Ah	XPWM module set control register 0 (write only)	0000h
XPWMPORT	EC80h	XPWM module port control register	0000h
XS1BG	E906h	XASC baudrate generator reload register	0000h
XS1CON	E900h	XASC control register	0000h
XS1CONCLR	E904h	XASC clear control register (write only)	0000h
XS1CONSET	E902h	XASC set control register (write only)	0000h
XS1PORT	E980h	XASC port control register	0000h
XS1RBUF	E90Ah	XASC receive buffer register	0000h
XS1TBUF	E908h	XASC transmit buffer register	0000h
XSSCBR	E80Ah	XSSC baudrate register	0000h
XSSCCON	E800h	XSSC control register	0000h
XSSCCONCLR	E804h	XSSC clear control register (write only)	0000h
XSSCCONSET	E802h	XSSC set control register (write only)	0000h
XSSCPORT	E880h	XSSC port control register	0000h
XSSCRB	E808h	XSSC receive buffer	XXXXh
XSSCTB	E806h	XSSC transmit buffer	0000h

### 23.3 Flash registers ordered by name

The following table lists all Flash control registers which are implemented in the ST10F272M ordered by their name. These registers are physically mapped on the IBus, except for XFVTAUR0, which is mapped on X-bus. Note that these registers are not bit-addressable.

**Table 47. List of Flash registers**

Name	Physical address	Description	Reset value
FARH	0x0008 0012	Flash address register - high	0000h
FARL	0x0008 0010	Flash address register - low	0000h
FCR0H	0x0008 0002	Flash control register 0 - high	0000h
FCR0L	0x0008 0000	Flash control register 0 - low	0000h
FCR1H	0x0008 0006	Flash control register 1 - high	0000h
FCR1L	0x0008 0004	Flash control register 1 - low	0000h
FDR0H	0x0008 000A	Flash data register 0 - high	FFFFh
FDR0L	0x0008 0008	Flash data register 0 - low	FFFFh
FDR1H	0x0008 000E	Flash data register 1 - high	FFFFh
FDR1L	0x0008 000C	Flash data register 1 - low	FFFFh
FER	0x0008 0014	Flash error register	0000h
FNVAPR0	0x0008 DFB8	Flash non-volatile access protection reg.0	ACFFh
FNVAPR1H	0x0008 DFBE	Flash non-volatile access protection reg.1 - high	FFFFh
FNVAPR1L	0x0008 DFBC	Flash non-volatile access protection reg.1 - low	FFFFh
FNVWPIR	0x0008 DFB0	Flash non-volatile protection I register	FFFFh
XFVTAUR0	0x0000 EB50	X-bus Flash volatile temporary access unprotection register 0	0000h

*Note:* XFVTAUR0 register is mapped on the X-bus in the XMiscellaneous window. Therefore XMISCEN, bit 10 of XPERCON register, must be set in order to access this register.



## 23.4 Identification registers

The ST10F272M has four identification registers, mapped in ESFR space. These registers contain:

- A manufacturer identifier
- A chip identifier with its revision
- An internal Flash and size identifier
- Programming voltage description

IDMANUF (F07Eh / 3Fh) ESFR Reset value: 0403h

15	14	13	12	11	10	9	8	7	6	5	4	3	2	1	0
MANUF											0	0	0	1	1
RO											RO	RO	RO	RO	RO

**Table 48. IDMANUF register description**

Bit	Name	Function
15:5	MANUF	Manufacturer identifier 020h: STMicroelectronics manufacturer (JTAG worldwide normalization)

IDCHIP (F07Ch / 3Eh) ESFR Reset value: 110Xh

15	14	13	12	11	10	9	8	7	6	5	4	3	2	1	0
IDCHIP											REVID				
RO											RO				

**Table 49. IDCHIP register description**

Bit	Name	Function
15:4	IDCHIP	Device identifier 110h: ST10F272M identifier (272)
3:0	REVID	Device revision identifier Xh: According to revision number

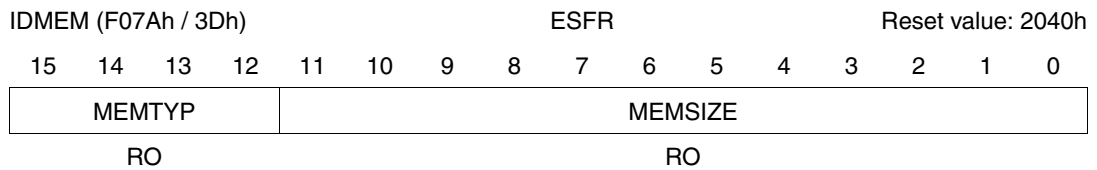

**Table 50. IDMEM register description**

Bit	Name	Function
15:12	MEMSIZE	Internal memory size Internal memory size is 4 x (MEMSIZE) (in Kbyte) 040h for 256 Kbytes (ST10F272M)
11:0	MEMTYP	Internal memory type 0h: ROM-Less 1h: (M) ROM memory 2h: (S) Standard Flash memory (ST10F272M) 3h: (H) High performance Flash memory 4h...Fh: Reserved

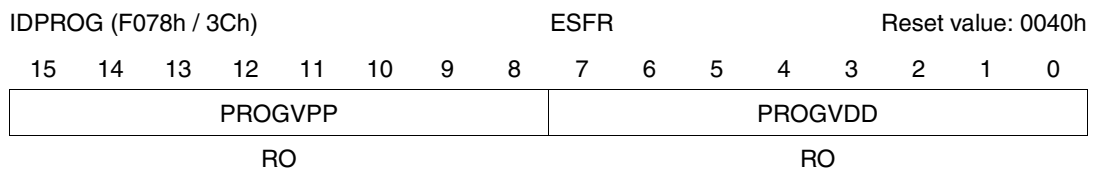

**Table 51. IDPROG register description**

Bit	Name	Function
15:8	PROGVPP	Programming V <sub>PP</sub> voltage (no need of external V <sub>PP</sub> ) - 00h
7:0	PROGVDD	Programming V <sub>DD</sub> voltage V <sub>DD</sub> voltage when programming EPROM or Flash devices is calculated using the following formula: V <sub>DD</sub> = 20 x [PROGVDD] / 256 (volts) - 40h for ST10F272M (5V).

*Note: All identification words are read-only registers.*

## 24 Electrical characteristics

### 24.1 Absolute maximum ratings

Table 52. Absolute maximum ratings

Symbol	Parameter	Values	Unit
$V_{DD}$	Voltage on $V_{DD}$ pins with respect to ground ( $V_{SS}$ )	-0.5 to +6.5	V
$V_{STBY}$	Voltage on $V_{STBY}$ pin with respect to ground ( $V_{SS}$ )	-0.5 to +6.5	V
$V_{AREF}$	Voltage on $V_{AREF}$ pins with respect to ground ( $V_{SS}$ )	-0.5 to $V_{DD} + 0.5$	V
$V_{AGND}$	Voltage on $V_{AGND}$ pins with respect to ground ( $V_{SS}$ )	$V_{SS}$	V
$V_{IO}$	Voltage on any pin with respect to ground ( $V_{SS}$ )	-0.5 to $V_{DD} + 0.5$	V
$I_{OV}$	Input current on any pin during overload condition	$\pm 10$	mA
$I_{TOV}$	Absolute sum of all input currents during overload condition	75	mA
$T_{ST}$	Storage temperature	-65 to +150	°C
ESD	ESD susceptibility (Human body model)	2000	V

**Note:** Stresses above those listed under ‘absolute maximum ratings’ may cause permanent damage to the device. This is a stress rating only and functional operation of the device at these or any other conditions above those indicated in the operational sections of this specification is not implied. Exposure to absolute maximum rating conditions for extended periods may affect device reliability. During overload conditions ( $V_{IN} > V_{DD}$  or  $V_{IN} < V_{SS}$ ) the voltage on pins with respect to ground ( $V_{SS}$ ) must not exceed the values defined by the absolute maximum ratings.

During power-on and power-off transients (including standby entering/exiting phases), the relationships between voltages applied to the device and the main  $V_{DD}$  must always be respected. In particular, power-on and power-off of  $V_{AREF}$  must be coherent with  $V_{DD}$  transient, in order to avoid undesired current injection through the on-chip protection diodes.

## 24.2 Recommended operating conditions

**Table 53. Recommended operating conditions**

Symbol	Parameter	Value		Unit
		Min	Max	
V <sub>DD</sub>	Operating supply voltage	4.5	5.5	V
V <sub>STBY</sub>	Operation stand-by supply voltage <sup>(1)</sup>			
V <sub>AREF</sub>	Operating analog reference voltage <sup>(2)</sup>	0	V <sub>DD</sub> + 0.1	
T <sub>A</sub>	Ambient temperature under bias	-40	+125	°C
T <sub>J</sub>	Junction temperature under bias		+150	

1. The value of the V<sub>STBY</sub> voltage is specified in the range of 4.5 to 5.5 volts. When V<sub>STBY</sub> voltage is lower than main V<sub>DD</sub>, the input section of V<sub>STBY</sub>/EA pin can generate a spurious static consumption on V<sub>DD</sub> power supply (in the range of tenth of μA).

2. For details on operating conditions concerning the usage of A/D converter refer to [Section 24.7](#).

## 24.3 Power considerations

The average chip-junction temperature, T<sub>J</sub>, in degrees Celsius, may be calculated using the following equation:

$$T_J = T_A + (P_D \times \Theta_{JA}) \quad (1)$$

Where:

T<sub>A</sub> is the ambient temperature in °C,

Θ<sub>JA</sub> is the package junction-to-ambient thermal resistance, in °C/W,

P<sub>D</sub> is the sum of P<sub>INT</sub> and P<sub>I/O</sub> (P<sub>D</sub> = P<sub>INT</sub> + P<sub>I/O</sub>)

P<sub>INT</sub> is the product of I<sub>DD</sub> and V<sub>DD</sub>, expressed in Watts. This is the chip internal power

P<sub>I/O</sub> represents the power dissipation on input and output pins; user determined.

Most of the time P<sub>I/O</sub> < P<sub>INT</sub> and may be neglected. On the other hand, P<sub>I/O</sub> may be significant if the device is configured to continuously drive external modules and/or memories.

An approximate relationship between P<sub>D</sub> and T<sub>J</sub> (if P<sub>I/O</sub> is neglected) is given by:

$$P_D = K / (T_J + 273^\circ\text{C}) \quad (2)$$

Therefore (solving equations 1 and 2):

$$K = P_D \times (T_A + 273^\circ\text{C}) + \Theta_{JA} \times P_D^2 \quad (3)$$

Where:

K is a constant for the particular part, which may be determined from equation (3) by measuring P<sub>D</sub> (at equilibrium) for a known T<sub>A</sub>. Using this value of K, the values of P<sub>D</sub> and T<sub>J</sub> may be obtained by solving equations (1) and (2) iteratively for any value of T<sub>A</sub>.

**Table 54. Thermal characteristics**

Symbol	Description	Value (typical)	Unit
$\Theta_{JA}$	Thermal resistance junction-ambient LQFP 144 - 20 x 20 mm/0.5 mm pitch	40	°C/W
	LQFP 144 - 20 x 20 mm/0.5 mm pitch on four-layer FR4 board (2 layers signals/2 layers power)	35	

Based on thermal characteristics of the package and with reference to the power consumption figures provided in the next tables and diagrams, the following product classification can be proposed. However, the exact power consumption of the device inside the application must be computed according to different working conditions, thermal profiles, real thermal resistance of the system (including printed circuit board or other substrata), I/O activity, and so on.

**Table 55. Package characteristics**

Package	Ambient temperature range	CPU frequency range
LQFP 144	-40 to +125°C	1 to 40 MHz

## 24.4 Parameter interpretation

The parameters listed in the following tables represent the characteristics of the ST10F272M and its demands on the system.

Where the ST10F272M logic provides signals with their respective timing characteristics, the symbol '**CC**' for controller characteristics, is included in the 'Symbol' column. Where the external system must provide signals with their respective timing characteristics to the ST10F272M, the symbol '**SR**' for system requirement, is included in the 'Symbol' column.

## 24.5 DC characteristics

$V_{DD} = 5\text{ V} \pm 10\%$ ,  $V_{SS} = 0\text{ V}$ ,  $T_A = -40\text{ to }+125\text{ }^\circ\text{C}$

**Table 56. DC characteristics**

Parameter	Symbol		Limit values		Unit	Test condition
			Min	Max		
Input low voltage (TTL mode) (except $\overline{\text{RSTIN}}$ , $\overline{\text{EA}}$ , $\overline{\text{NMI}}$ , RPD, XTAL1, READY)	$V_{IL}$	SR	-0.3	0.8	V	–
Input low voltage (CMOS mode) (except $\overline{\text{RSTIN}}$ , $\overline{\text{EA}}$ , $\overline{\text{NMI}}$ , RPD, XTAL1, READY)	$V_{ILS}$	SR	-0.3	$0.3 V_{DD}$	V	–
Input low voltage $\overline{\text{RSTIN}}$ , $\overline{\text{EA}}$ , $\overline{\text{NMI}}$ , RPD	$V_{IL1}$	SR	-0.3	$0.3 V_{DD}$	V	–
Input low voltage XTAL1 (CMOS only)	$V_{IL2}$	SR	-0.3	$0.3 V_{DD}$	V	Direct drive mode
Input low voltage READY (TTL only)	$V_{IL3}$	SR	-0.3	0.8	V	–
Input high voltage (TTL mode) (except $\overline{\text{RSTIN}}$ , $\overline{\text{EA}}$ , $\overline{\text{NMI}}$ , RPD, XTAL1)	$V_{IH}$	SR	2.0	$V_{DD} + 0.3$	V	–
Input high voltage (CMOS mode) (except $\overline{\text{RSTIN}}$ , $\overline{\text{EA}}$ , $\overline{\text{NMI}}$ , RPD, XTAL1)	$V_{IHS}$	SR	$0.7 V_{DD}$	$V_{DD} + 0.3$	V	–
Input high voltage $\overline{\text{RSTIN}}$ , $\overline{\text{EA}}$ , $\overline{\text{NMI}}$ , RPD	$V_{IH1}$	SR	$0.7 V_{DD}$	$V_{DD} + 0.3$	V	–
Input high voltage XTAL1 (CMOS only)	$V_{IH2}$	SR	$0.7 V_{DD}$	$V_{DD} + 0.3$	V	Direct drive mode
Input high voltage READY (TTL only)	$V_{IH3}$	SR	2.0	$V_{DD} + 0.3$	V	–
Input hysteresis (TTL mode) (except $\overline{\text{RSTIN}}$ , $\overline{\text{EA}}$ , $\overline{\text{NMI}}$ , XTAL1, RPD)	$V_{HYS}$	CC	400	700	mV	(1)
Input hysteresis (CMOS mode) (except $\overline{\text{RSTIN}}$ , $\overline{\text{EA}}$ , $\overline{\text{NMI}}$ , XTAL1, RPD)	$V_{HYSS}$	CC	750	1400	mV	(1)
Input hysteresis $\overline{\text{RSTIN}}$ , $\overline{\text{EA}}$ , $\overline{\text{NMI}}$	$V_{HYS1}$	CC	750	1400	mV	(1)
Input hysteresis XTAL1	$V_{HYS2}$	CC	0	50	mV	(1)
Input hysteresis READY (TTL only)	$V_{HYS3}$	CC	400	700	mV	(1)
Input hysteresis RPD	$V_{HYS4}$	CC	500	1500	mV	(1)
Output low voltage (P6[7:0], ALE, $\overline{\text{RD}}$ , $\overline{\text{WR/WRL}}$ , $\overline{\text{BHE/WRH}}$ , CLKOUT, $\overline{\text{RSTIN}}$ , $\overline{\text{RSTOUT}}$ )	$V_{OL}$	CC	–	0.4 0.05	V	$I_{OL} = 8\text{ mA}$ $I_{OL} = 1\text{ mA}$
Output low voltage (P0[15:0], P1[15:0], P2[15:0], P3[15,13:0], P4[7:0], P7[7:0], P8[7:0])	$V_{OL1}$	CC	–	0.4 0.05	V	$I_{OL1} = 4\text{ mA}$ $I_{OL1} = 0.5\text{ mA}$
Output low voltage RPD	$V_{OL2}$	CC	–	$V_{DD}$ $0.5 V_{DD}$ $0.3 V_{DD}$	V	$I_{OL2} = 85\text{ }\mu\text{A}$ $I_{OL2} = 80\text{ }\mu\text{A}$ $I_{OL2} = 60\text{ }\mu\text{A}$
Output high voltage (P6[7:0], ALE, $\overline{\text{RD}}$ , $\overline{\text{WR/WRL}}$ , $\overline{\text{BHE/WRH}}$ , CLKOUT, $\overline{\text{RSTOUT}}$ )	$V_{OH}$	CC	$V_{DD} - 0.8$ $V_{DD} - 0.08$	–	V	$I_{OH} = -8\text{ mA}$ $I_{OH} = -1\text{ mA}$

Table 56. DC characteristics (continued)

Parameter	Symbol		Limit values		Unit	Test condition
			Min	Max		
Output high voltage <sup>(2)</sup> (P0[15:0], P1[15:0], P2[15:0], P3[15,13:0], P4[7:0], P7[7:0], P8[7:0])	V <sub>OH1</sub>	CC	V <sub>DD</sub> - 0.8 V <sub>DD</sub> - 0.08	–	V	I <sub>OH1</sub> = – 4 mA I <sub>OH1</sub> = – 0.5 mA
Output high voltage RPD	V <sub>OH2</sub>	CC	0 0.3 V <sub>DD</sub> 0.5 V <sub>DD</sub>	–	V	I <sub>OH2</sub> = – 2 mA I <sub>OH2</sub> = – 750 μA I <sub>OH2</sub> = – 150 μA
Input leakage current (P5[15:0]) <sup>(3)</sup>	I <sub>OZ1</sub>	CC	–	±0.2	μA	–
Input leakage current (all except P5[15:0], P2[0], RPD, P3[12], P3[15])	I <sub>OZ2</sub>	CC	–	±0.5	μA	–
Input leakage current (P2[0]) <sup>(4)</sup>	I <sub>OZ3</sub>	CC	–	+1.0 -0.5	μA	–
Input leakage current (RPD)	I <sub>OZ4</sub>	CC	–	±3.0	μA	–
Input leakage current (P3[12], P3[15])	I <sub>OZ5</sub>	CC	–	±1.0	μA	–
Overload current (all except P2[0])	I <sub>OV1</sub>	SR	–	±5	mA	(1)(5)
Overload current (P2[0]) <sup>(4)</sup>	I <sub>OV2</sub>	SR	–	+5 -1	mA	(1)(5)
RSTIN pull-up resistor	R <sub>RST</sub>	CC	50	250	kΩ	100 kΩ nominal
Read/write inactive current <sup>(6)(7)</sup>	I <sub>RWH</sub>		–	-40	μA	V <sub>OUT</sub> = 2.4 V
Read/write active current <sup>(6)(8)</sup>	I <sub>RWL</sub>		-500	–	μA	V <sub>OUT</sub> = 0.4 V
ALE inactive current <sup>(6)(7)</sup>	I <sub>ALEL</sub>		20	–	μA	V <sub>OUT</sub> = 0.4 V
ALE active current <sup>(6)(8)</sup>	I <sub>ALEH</sub>		–	300	μA	V <sub>OUT</sub> = 2.4 V
Port 6 inactive current (P6[4:0]) <sup>(6)(7)</sup>	I <sub>P6H</sub>		–	-40	μA	V <sub>OUT</sub> = 2.4 V
Port 6 active current (P6[4:0]) <sup>(6)(8)</sup>	I <sub>P6L</sub>		-500	–	μA	V <sub>OUT</sub> = 0.4 V
PORT0 configuration current <sup>(6)</sup>	I <sub>P0H</sub> <sup>(6)</sup>		–	-10	μA	V <sub>IN</sub> = 2.0 V
	I <sub>P0L</sub> <sup>(7)</sup>		-100	–	μA	V <sub>IN</sub> = 0.8 V
Pin capacitance (digital inputs/outputs)	C <sub>IO</sub>	CC	–	10	pF	(1)(6)
Run mode power supply current <sup>(9)</sup> (execution from internal RAM)	I <sub>CC1</sub>		–	15 + 1.5 f <sub>CPU</sub>	mA	–
Run mode power supply current <sup>(1)(9)</sup> (execution from internal Flash)	I <sub>CC2</sub>		–	15 + 1.5 f <sub>CPU</sub>	mA	–
Idle mode supply current <sup>(10)</sup>	I <sub>ID</sub>		–	15 + 0.6 f <sub>CPU</sub>	mA	–
Power-down supply current <sup>(11)</sup> (RTC off, oscillators off, Main voltage regulator off)	I <sub>PD1</sub>		–	150	μA	T <sub>A</sub> = 25 °C
Power-down supply current <sup>(11)</sup> (RTC on, main oscillator on, Main voltage regulator off)	I <sub>PD2</sub>		–	400 typical value	μA	T <sub>A</sub> = 25 °C

Table 56. DC characteristics (continued)

Parameter	Symbol	Limit values		Unit	Test condition
		Min	Max		
Power-down supply current <sup>(11)</sup> (RTC on, 32 kHz oscillator on, Main voltage regulator off)	I <sub>PD3</sub>	–	200	μA	T <sub>A</sub> = 25 °C
Stand-by supply current <sup>(11)</sup> (RTC off, oscillators off, V <sub>DD</sub> off, V <sub>STBY</sub> on)	I <sub>SB1</sub>	–	120	μA	V <sub>STBY</sub> = 5.5 V T <sub>A</sub> = T <sub>J</sub> = 25 °C
		–	500	μA	V <sub>STBY</sub> = 5.5 V T <sub>A</sub> = T <sub>J</sub> = 125 °C
Stand-by supply current <sup>(11)</sup> (RTC on, 32 kHz oscillator on, main V <sub>DD</sub> off, V <sub>STBY</sub> on)	I <sub>SB2</sub>	–	120	μA	V <sub>STBY</sub> = 5.5 V T <sub>A</sub> = T <sub>J</sub> = 25 °C
		–	500	μA	V <sub>STBY</sub> = 5.5 V T <sub>A</sub> = T <sub>J</sub> = 125 °C
Stand-by supply current <sup>(1)(11)</sup> (V <sub>DD</sub> transient condition)	I <sub>SB3</sub>	–	2.5	mA	–

- Not 100% tested, guaranteed by design characterization.
- This specification is not valid for outputs which are switched to open drain mode. In this case the respective output will float and the voltage is imposed by the external circuitry.
- Port 5 leakage values are granted for not selected A/D converter channel. One channel is always selected (by default, after reset, P5.0 is selected). For the selected channel the leakage value is similar to that of other port pins.
- The leakage of P2.0 is higher than other pins due to the additional logic (pass gates active only in specific test modes) implemented on input path. Pay attention to not stress P2.0 input pin with negative overload beyond the specified limits: failures in Flash reading may occur (sense amplifier perturbation). Refer to next [Figure 37](#) for a scheme of the input circuitry.
- Overload conditions occur if the standard operating conditions are exceeded, that is, the voltage on any pin exceeds the specified range (that is, V<sub>OV</sub> > V<sub>DD</sub> + 0.3 V or V<sub>OV</sub> < -0.3 V). The absolute sum of input overload currents on all port pins may not exceed 50 mA. The supply voltage must remain within the specified limits.
- This specification is only valid during reset, or during hold- or adapt-mode. Port 6 pins are only affected, if they are used for CS output and the open drain function is not enabled.
- The maximum current may be drawn while the respective signal line remains inactive.
- The minimum current must be drawn in order to drive the respective signal line active.
- The power supply current is a function of the operating frequency (f<sub>CPU</sub> is expressed in MHz). This dependency is illustrated in [Figure 38](#) below. This parameter is tested at V<sub>DDmax</sub> and at maximum CPU clock frequency with all outputs disconnected and all inputs at V<sub>IL</sub> or V<sub>IH</sub>, RSTIN pin at V<sub>IH1min</sub>. This implies I/O current is not considered. The device is doing the following:  
 Fetching code from IRAM and XRAM1, accessing in read and write to both XRAM modules  
 Watchdog timer is enabled and regularly serviced  
 RTC is running with main oscillator clock as reference, generating a tick interrupts every 192 clock cycles  
 Four channel of XPWM are running (waves period: 2, 2.5, 3 and 4 CPU clock cycles): no output toggling  
 Five general purpose timers are running in timer mode with prescaler equal to 8 (T2, T3, T4, T5, T6)  
 ADC is in autoscan continuous conversion mode on all 16 channels of port5  
 All interrupts generated by XPWM, RTC, timers and ADC are not serviced
- The idle mode supply current is a function of the operating frequency (f<sub>CPU</sub> is expressed in MHz). This dependency is illustrated in [Figure 37](#) below. These parameters are tested and at maximum CPU clock with all outputs disconnected and all inputs at V<sub>IL</sub> or V<sub>IH</sub>, RSTIN pin at V<sub>IH1min</sub>.
- This parameter is tested including leakage currents. All inputs (including pins configured as inputs) at 0 V to 0.1 V or at V<sub>DD</sub> - 0.1V to V<sub>DD</sub>, V<sub>AREF</sub> = 0V, all outputs (including pins configured as outputs) disconnected. Also, the main voltage regulator is assumed to be off; if it is not, an additional 1mA must be added.



Figure 37. Port2 test mode structure

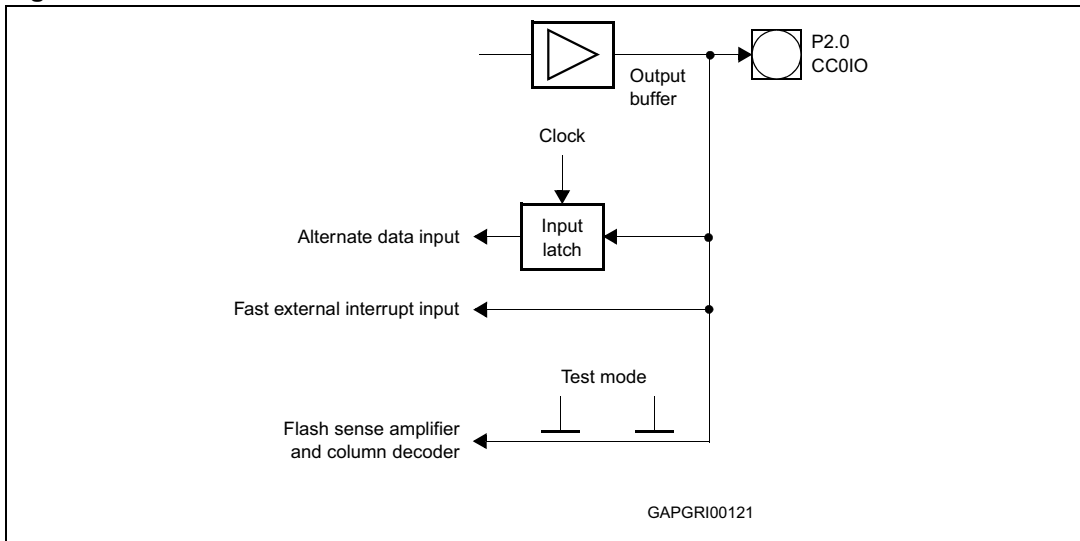
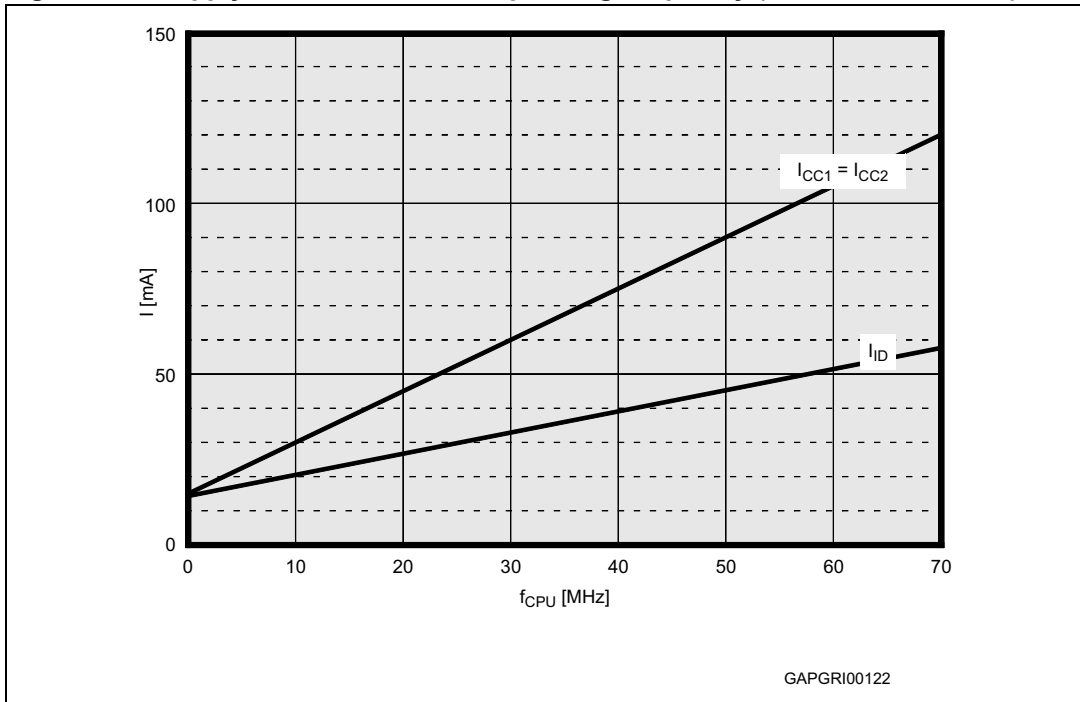

Figure 38. Supply current versus the operating frequency (run and idle modes)



## 24.6 Flash characteristics

$V_{DD} = 5\text{ V} \pm 10\%$ ,  $V_{SS} = 0\text{ V}$

**Table 57. Flash characteristics**

Parameter	Typical	Maximum		Unit	Notes
	$T_A = 25\text{ °C}$	$T_A = 125\text{ °C}$			
	0 cycles <sup>(1)</sup>	0 cycles <sup>(1)</sup>	100 k cycles		
Word program (32-bit) <sup>(2)</sup>	35	80	290	μs	–
Double word program (64-bit) <sup>(2)</sup>	60	150	570	μs	–
Bank 0 program (256 Kbyte) (double word program)	1.6	2.0	3.9	s	–
Sector erase (8 Kbyte)	0.6 0.5	0.9 0.8	1.0 0.9	s	Not preprogrammed Preprogrammed
Sector erase (32 Kbyte)	1.1 0.8	2.0 1.8	2.7 2.5	s	Not preprogrammed Preprogrammed
Sector erase (64 Kbyte)	1.7 1.3	3.7 3.3	5.1 4.7	s	Not preprogrammed Preprogrammed
Bank 0 erase (256 Kbyte) <sup>(3)</sup>	5.6 4.0	13.6 11.9	19.2 17.5	s	Not preprogrammed Preprogrammed
Recovery from power-down ( $t_{PD}$ )	–	40	40	μs	<sup>(4)</sup>
Program suspend latency <sup>(4)</sup>	–	10	10	μs	–
Erase suspend latency <sup>(4)</sup>	–	30	30	μs	–
Erase suspend request rate <sup>(4)</sup>	20	20	20	ms	Minimum delay between two requests
Set protection <sup>(4)</sup>	40	90	300	μs	–

1. The figures are given after about 100 cycles due to testing routines (0 cycles at the final customer).
2. Word and double word programming times are provided as average values derived from a full sector programming time. Absolute value of a word or double word programming time could be longer than the average value.
3. Bank erase is obtained through a multiple sector erase operation (setting bits related to all sectors of the bank). As ST10F272M implements only one bank, the bank erase operation is equivalent to module and chip erase operations.
4. Not 100% tested, guaranteed by design characterization.

Table 58. Flash data retention characteristics

Number of program/erase cycles ( $-40\text{ °C} \leq T_A \leq 125\text{ °C}$ )	Data retention time (average ambient temperature $60\text{ °C}$ )	
	256 Kbyte (code store)	64 Kbyte (EEPROM emulation) <sup>(1)</sup>
0 - 100	> 20 years	> 20 years
1000	-	> 20 years
10000	-	10 years
100000	-	1 year

1. Two 64 Kbyte Flash sectors may be typically used to emulate up to 4, 8 or 16 Kbytes of EEPROM. Therefore, in case of an emulation of a 16 Kbyte EEPROM, 100,000 Flash program/erase cycles are equivalent to 800,000 EEPROM Program/Erase cycles. For an efficient use of the EEPROM emulation please refer to dedicated application note document ([AN2061 - "EEPROM Emulation with ST10F2xx"](#)). Contact your local field service, local sales person or STMicroelectronics representative to obtain a copy of such a guideline document.

## 24.7 A/D converter characteristics

$V_{DD} = 5\text{ V} \pm 10\%$ ,  $V_{SS} = 0\text{ V}$ ,  $T_A = -40\text{ to }+125\text{ °C}$ ,  $4.5\text{ V} \leq V_{AREF} \leq V_{DD}$ ,  
 $V_{SS} \leq V_{AGND} \leq V_{SS} + 0.2\text{ V}$

Table 59. A/D converter characteristics

Parameter	Symbol		Limit values		Unit	Test condition
			Min	Max		
Analog reference voltage <sup>(1)</sup>	$V_{AREF}$	SR	4.5	$V_{DD}$	V	
Analog ground voltage	$V_{AGND}$	SR	$V_{SS}$	$V_{SS} + 0.2$	V	
Analog input voltage <sup>(2)</sup>	$V_{AIN}$	SR	$V_{AGND}$	$V_{AREF}$	V	
Reference supply current	$I_{AREF}$	CC	-	5 1	mA μA	Running mode <sup>(3)</sup> Power-down mode
Sample time	$t_S$	CC	1	-	μs	<sup>(4)</sup>
Conversion time	$t_C$	CC	3	-	μs	<sup>(5)</sup>
Differential nonlinearity <sup>(6)</sup>	DNL	CC	-1	+1	LSB	No overload
Integral nonlinearity <sup>(6)</sup>	INL	CC	-1.5	+1.5	LSB	No overload
Offset error <sup>(6)</sup>	OFS	CC	-1.5	+1.5	LSB	No overload
Total unadjusted error <sup>(6)</sup>	TUE	CC	-2.0 -5.0 -7.0	+2.0 +5.0 +7.0	LSB	Port5 Port1 - no overload <sup>(3)</sup> Port1 - overload <sup>(3)</sup>
Coupling factor between inputs <sup>(3)(7)</sup>	K	CC	-	$10^{-6}$	-	On both Port5 and Port1
Input pin capacitance <sup>(3)(8)</sup>	$C_{P1}$	CC	-	3	pF	
	$C_{P2}$	CC	-	4 6	pF	Port5 Port1
Sampling capacitance <sup>(3)(8)</sup>	$C_S$	CC	-	3.5	pF	

**Table 59. A/D converter characteristics (continued)**

Parameter	Symbol		Limit values		Unit	Test condition
			Min	Max		
Analog switch resistance <sup>(3)(8)</sup>	R <sub>SW</sub>	CC	–	600	W	Port5 Port1
			–	1600		
	R <sub>AD</sub>	CC	–	1300	W	

- V<sub>AREF</sub> can be tied to ground when A/D converter is not in use. There is increased consumption (approximately 200 µA) on main V<sub>DD</sub> due to internal analog circuitry not being completely turned off. Therefore, it is suggested to maintain the V<sub>AREF</sub> at V<sub>DD</sub> level even when not in use, and to eventually switch off the A/D converter circuitry setting bit ADOFF in ADCON register.
- V<sub>AIN</sub> may exceed V<sub>AGND</sub> or V<sub>AREF</sub> up to the absolute maximum ratings. However, the conversion result in these cases will be 0x000<sub>H</sub> or 0x3FF<sub>H</sub>, respectively
- Not 100% tested, guaranteed by design characterization
- During the sample time the input capacitance C<sub>AIN</sub> can be charged/discharged by the external source. The internal resistance of the analog source must allow the capacitance to reach its final voltage level within t<sub>S</sub>. After the end of the sample time t<sub>S</sub>, changes of the analog input voltage have no effect on the conversion result. Values for the sample clock t<sub>S</sub> depend on programming and can be taken from [Table 60: A/D converter programming](#).
- This parameter includes the sample time t<sub>S</sub>, the time for determining the digital result and the time to load the result register with the conversion result. Values for the conversion clock t<sub>CC</sub> depend on programming and can be taken from the next [Table 60](#).
- DNL, INL, OFS and TUE are tested at V<sub>AREF</sub> = 5.0 V, V<sub>AGND</sub> = 0 V, V<sub>DD</sub> = 5.0 V. It is guaranteed by design characterization for all other voltages within the defined voltage range. 'LSB' has a value of V<sub>AREF</sub>/1024. For port5 channels, the specified TUE (± 2 LSB) is guaranteed also with an overload condition (see I<sub>OY</sub> specification) occurring on maximum 2 not selected analog input pins of port5 and the absolute sum of input overload currents on all Port5 analog input pins does not exceed 10 mA. For port1 channels, the specified TUE is guaranteed when no overload condition is applied to port1 pins: when an overload condition occurs on maximum 2 not selected analog input pins of port1 and the input positive overload current on all analog input pins does not exceed 10 mA (either dynamic or static injection), the specified TUE is degraded (± 7 LSB). To obtain the same accuracy, the negative injection current on port1 pins must not exceed -1mA in case of both dynamic and static injection.
- The coupling factor is measured on a channel while an overload condition occurs on the adjacent not selected channels with the overload current within the different specified ranges (for both positive and negative injection current).
- Refer to scheme shown in [Figure 40](#).

### 24.7.1 Conversion timing control

When a conversion is started, first the capacitances of the converter are loaded via the respective analog input pin to the current analog input voltage. The time to load the capacitances is referred to as sample time. Next the sampled voltage is converted to a digital value several successive steps, which correspond to the 10-bit resolution of the ADC. During these steps the internal capacitances are repeatedly charged and discharged via the V<sub>AREF</sub> pin.

The current that has to be drawn from the sources for sampling and changing charges depends on the time that each respective step takes, because the capacitors must reach their final voltage level within the given time, at least with a certain approximation. The maximum current, however, that a source can deliver, depends on its internal resistance.

The time that the two different actions during conversion take (sampling, and converting) can be programmed within a certain range in the ST10F272M relative to the CPU clock. The absolute time that is consumed by the different conversion steps therefore is independent from the general speed of the controller. This allows adjustment of the ST10F272M A/D converter to the system's properties:

**Fast conversion** can be achieved by programming the respective times to their absolute possible minimum. This is preferable for scanning high frequency signals. The internal resistance of analog source and analog supply must be sufficiently low, however.

**High internal resistance** can be achieved by programming the respective times to a higher value, or the possible maximum. This is preferable when using analog sources and supply with a high internal resistance in order to keep the current as low as possible. The conversion rate in this case may be considerably lower, however.

The conversion times are programmed via the upper four bits of register ADCON. Bit fields ADCTC and ADSTC are used to define the basic conversion time and in particular the partition between sample phase and comparison phases. The table below lists the possible combinations. The timings refer to the unit TCL, where  $f_{CPU} = 1/2 \text{ TCL}$ . A complete conversion time includes the conversion itself, the sample time and the time required to transfer the digital value to the result register.

**Table 60. A/D converter programming**

ADCTC	ADSTC	Sample	Comparison	Extra	Total conversion
00	00	TCL * 120	TCL * 240	TCL * 28	TCL * 388
00	01	TCL * 140	TCL * 280	TCL * 16	TCL * 436
00	10	TCL * 200	TCL * 280	TCL * 52	TCL * 532
00	11	TCL * 400	TCL * 280	TCL * 44	TCL * 724
11	00	TCL * 240	TCL * 480	TCL * 52	TCL * 772
11	01	TCL * 280	TCL * 560	TCL * 28	TCL * 868
11	10	TCL * 400	TCL * 560	TCL * 100	TCL * 1060
11	11	TCL * 800	TCL * 560	TCL * 52	TCL * 1444
10	00	TCL * 480	TCL * 960	TCL * 100	TCL * 1540
10	01	TCL * 560	TCL * 1120	TCL * 52	TCL * 1732
10	10	TCL * 800	TCL * 1120	TCL * 196	TCL * 2116
10	11	TCL * 1600	TCL * 1120	TCL * 164	TCL * 2884

*Note:* The total conversion time is compatible with the formula valid for ST10F269, while the meaning of the bit fields ADCTC and ADSTC is no longer compatible: the minimum conversion time is 388 TCL, which at 40 MHz CPU frequency corresponds to 4.85  $\mu\text{s}$  (see ST10F269).

### 24.7.2 A/D conversion accuracy

The A/D converter compares the analog voltage sampled on the selected analog input channel to its analog reference voltage ( $V_{AREF}$ ) and converts it into 10-bit digital data. The absolute accuracy of the A/D conversion is the deviation between the input analog value and the output digital value. It includes the following errors:

- Offset error (OFS)
- Gain error (GE)
- Quantization error
- Nonlinearity error (differential and integral)

These four error quantities are explained below using [Figure 39](#).

### Offset error

Offset error is the deviation between actual and ideal A/D conversion characteristics when the digital output value changes from the minimum (zero voltage) 00 to 01 ([Figure 39](#), see OFS).

### Gain error

Gain error is the deviation between the actual and ideal A/D conversion characteristics when the digital output value changes from the 3FE to the maximum 3FF, once offset error is subtracted. Gain error combined with offset error represents the so-called full-scale error ([Figure 39](#), OFS + GE).

### Quantization error

Quantization error is the intrinsic error of the A/D converter and is expressed as 1/2 LSB.

### Nonlinearity error

Nonlinearity error is the deviation between actual and the best-fitting A/D conversion characteristics (see [Figure 39](#)):

- Differential nonlinearity error is the actual step dimension versus the ideal one (1  $\text{LSB}_{\text{IDEAL}}$ ).
- Integral nonlinearity error is the distance between the center of the actual step and the center of the bisector line, in the actual characteristics. Note that for integral nonlinearity error, the effect of offset, gain and quantization errors is not included.

*Note:* *Bisector characteristic is obtained drawing a line from 1/2 LSB before the first step of the real characteristic, and 1/2 LSB after the last step again of the real characteristic.*

## 24.7.3 Total unadjusted error

The total unadjusted error specifies the maximum deviation from the ideal characteristic: the number provided in the data sheet represents the maximum error with respect to the entire characteristic. It is a combination of the offset, gain and integral linearity errors. The different errors may compensate each other depending on the relative sign of the offset and gain errors. Refer to [Figure 39](#), see TUE.

Figure 39. A/D conversion characteristics

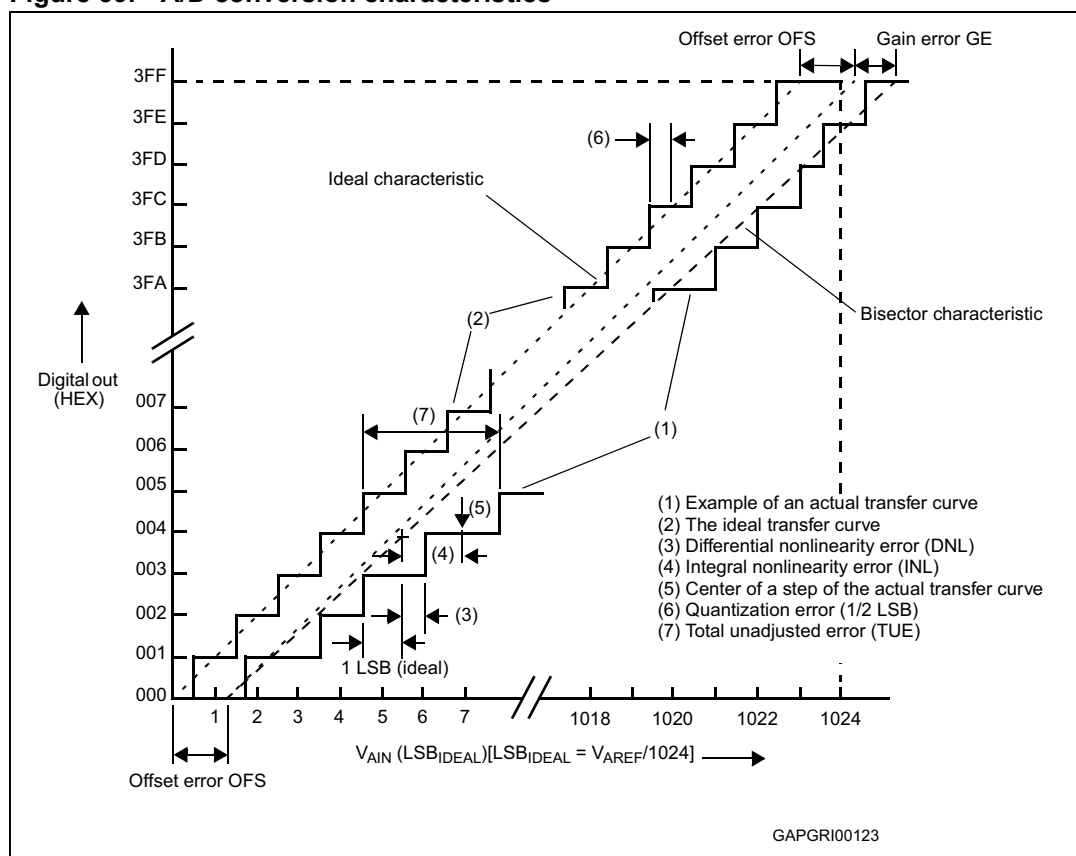

#### 24.7.4 Analog reference pins

The accuracy of the A/D converter depends on how accurate is its analog reference: a noise in the reference results in at least that much error in a conversion. A low pass filter on the A/D converter reference source (supplied through pins  $V_{AREF}$  and  $V_{AGND}$ ), is recommended in order to clean the signal, minimizing the noise. A simple capacitive bypassing may be sufficient in most of the cases; in presence of high RF noise energy, inductors or ferrite beads may be necessary.

In this architecture,  $V_{AREF}$  and  $V_{AGND}$  pins represents also the power supply of the analog circuitry of the A/D converter: there is an effective DC current requirement from the reference voltage by the internal resistor string in the R-C DAC array and by the rest of the analog circuitry.

An external resistance on  $V_{AREF}$  could introduce error under certain conditions: for this reasons, series resistance are not advisable, and more in general any series devices in the filter network should be designed to minimize the DC resistance.

#### Analog input pins

To improve the accuracy of the A/D converter, it is definitively necessary that analog input pins have low AC impedance. Placing a capacitor with good high frequency characteristics at the input pin of the device, can be effective: the capacitor should be as large as possible, ideally infinite. This capacitor contributes to attenuating the noise present on the input pin.

Moreover, it sources charge during the sampling phase, when the analog signal source is a high-impedance source.

A real filter, can typically be obtained by using a series resistance with a capacitor on the input pin (simple RC Filter). The RC filtering may be limited according to the value of source impedance of the transducer or circuit supplying the analog signal to be measured. The filter at the input pins must be designed taking into account the dynamic characteristics of the input signal (bandwidth).

**Figure 40. A/D converter input pins scheme**

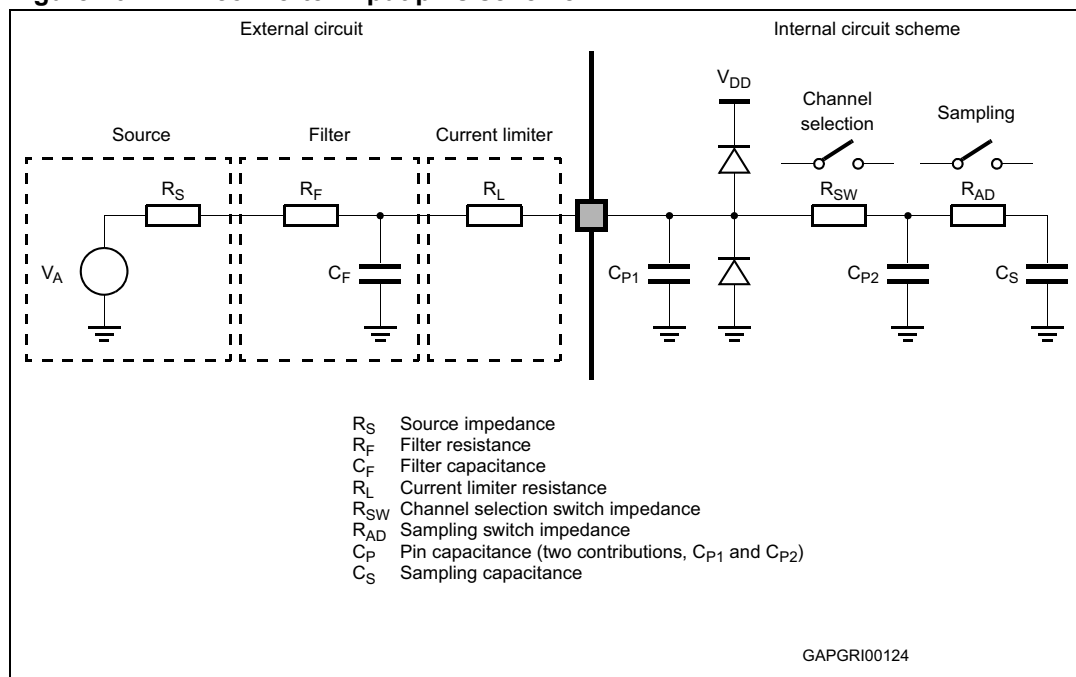

**Input leakage and external circuit**

The series resistor utilized to limit the current to a pin (see  $R_L$  in [Figure 40](#)), in combination with a large source impedance can lead to a degradation of A/D converter accuracy when input leakage is present.

Data about maximum input leakage current at each pin is provided in [Table 56: DC characteristics on page 126](#). Input leakage is greatest at high operating temperatures, and in general it decreases by one half for each 10°C decrease in temperature.

Considering that, for a 10-bit A/D converter one count is about 5mV (assuming  $V_{AREF} = 5\text{ V}$ ), an input leakage of 100 nA acting through an  $R_L = 50\text{ k}\Omega$  of external resistance leads to an error of exactly one count (5 mV); if the resistance were 100 kΩ the error would become two counts.

Eventual additional leakage due to external clamping diodes must also be taken into account in computing the total leakage affecting the A/D converter measurements. Another contribution to the total leakage is represented by the charge sharing effects with the sampling capacitance: being  $C_S$  substantially a switched capacitance, with a frequency equal to the conversion rate of a single channel (maximum when fixed channel continuous conversion mode is selected), it can be seen as a resistive path to ground. For instance, assuming a conversion rate of 250 kHz, with  $C_S$  equal to 4 pF, a resistance of 1 MΩ is obtained ( $R_{EQ} = 1/f_C C_S$ , where  $f_C$  represents the conversion rate at the considered



channel). To minimize the error induced by the voltage partitioning between this resistance (sampled voltage on  $C_S$ ) and the sum of  $R_S + R_F + R_L + R_{SW} + R_{AD}$ , the external circuit must be designed to respect the following relation:

$$V_A \cdot \frac{R_S + R_F + R_L + R_{SW} + R_{AD}}{R_{EQ}} < \frac{1}{2} \text{LSB}$$

The formula above provides constraints for external network design, in particular on resistive path.

A second aspect involving the capacitance network must be considered. Assuming the three capacitances  $C_F$ ,  $C_{P1}$  and  $C_{P2}$  initially charged at the source voltage  $V_A$  (refer to the equivalent circuit shown in [Figure 40](#)), when the sampling phase is started (A/D switch close), a charge sharing phenomena is installed.

**Figure 41. Charge sharing timing diagram during sampling phase**

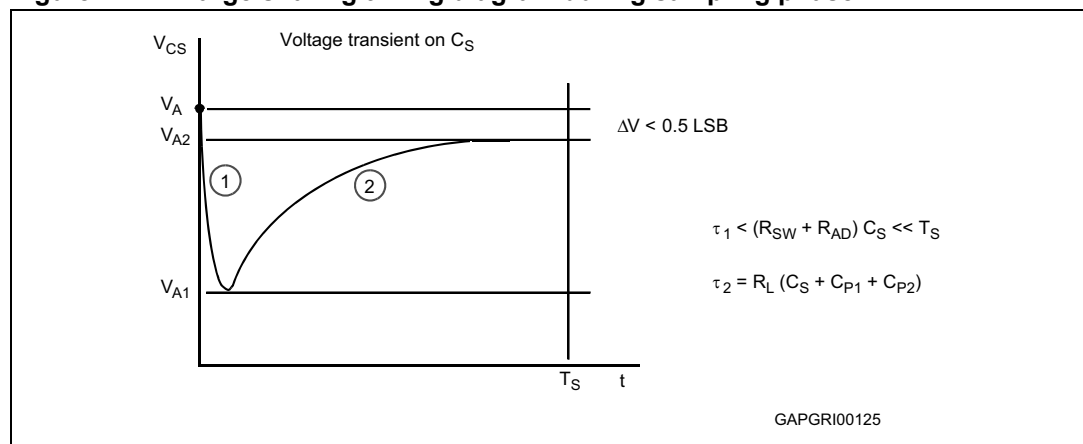

In particular two different transient periods can be distinguished (see [Figure 41](#)):

- A first and quick charge transfer from the internal capacitance  $C_{P1}$  and  $C_{P2}$  to the sampling capacitance  $C_S$  occurs ( $C_S$  is supposed initially completely discharged): considering a worst case (since the time constant in reality would be faster) in which  $C_{P2}$  is shown in parallel to  $C_{P1}$  (call  $C_P = C_{P1} + C_{P2}$ ), the two capacitance  $C_P$  and  $C_S$  are in series, and the time constant is:

$$\tau_1 = (R_{SW} + R_{AD}) \cdot \frac{C_P \cdot C_S}{C_P + C_S}$$

This relation can again be simplified considering only  $C_S$  as an additional worst condition. In reality, the transient is faster, but the A/D converter circuitry has been designed to be robust also in the very worst case: the sampling time  $T_S$  is always much longer than the internal time constant:

$$\tau_1 < (R_{SW} + R_{AD}) \cdot C_S < T_S$$

The charge of  $C_{P1}$  and  $C_{P2}$  is redistributed also on  $C_S$ , determining a new value of the voltage  $V_{A1}$  on the capacitance according to the following equation:

$$V_{A1} \cdot (C_S + C_{P1} + C_{P2}) = V_A \cdot (C_{P1} + C_{P2})$$

- A second charge transfer involves also  $C_F$  (that is typically bigger than the on-chip capacitance) through the resistance  $R_L$ : again considering the worst case in which  $C_{P2}$  and  $C_S$  were in parallel to  $C_{P1}$  (since the time constant in reality would be faster), the time constant is:

$$\tau_2 < R_L \cdot (C_S + C_{P1} + C_{P2})$$

In this case, the time constant depends on the external circuit: in particular imposing that the transient is completed well before the end of sampling time  $T_S$ , a constraint on  $R_L$  sizing is obtained:

$$10 \cdot \tau_2 = 10 \cdot R_L \cdot (C_S + C_{P1} + C_{P2}) \leq T_S$$

Of course,  $R_L$  must also be sized according to the current limitation constraints, in combination with  $R_S$  (source impedance) and  $R_F$  (filter resistance). Being  $C_F$  definitively bigger than  $C_{P1}$ ,  $C_{P2}$  and  $C_S$ , then the final voltage  $V_{A2}$  (at the end of the charge transfer transient) will be much higher than  $V_{A1}$ . The following equation must be respected (charge balance assuming now  $C_S$  already charged at  $V_{A1}$ ):

$$V_{A2}(C_S + C_{P1} + C_{P2} + C_F) = V_A \cdot C_F + V_{A1}(C_{P1} + C_{P2} + C_S)$$

The two transients above are not influenced by the voltage source that, due to the presence of the  $R_F C_F$  filter, is not able to provide the extra charge to compensate the voltage drop on  $C_S$  with respect to the ideal source  $V_A$ ; the time constant  $R_F C_F$  of the filter is very high with respect to the sampling time ( $T_S$ ). The filter is typically designed to act as anti-aliasing (see [Figure 42](#)).

Calling  $f_0$  the bandwidth of the source signal (and as a consequence the cut-off frequency of the anti-aliasing filter,  $f_F$ ), according to Nyquist theorem the conversion rate  $f_C$  must be at least  $2f_0$ ; it means that the constant time of the filter is greater than or at least equal to twice the conversion period ( $T_C$ ). Again the conversion period  $T_C$  is longer than the sampling time  $T_S$ , which is just a portion of it, even when fixed channel continuous conversion mode is selected (fastest conversion rate at a specific channel): in conclusion it is evident that the time constant of the filter  $R_F C_F$  is definitively much higher than the sampling time  $T_S$ , so the charge level on  $C_S$  cannot be modified by the analog signal source during the time in which the sampling switch is closed.

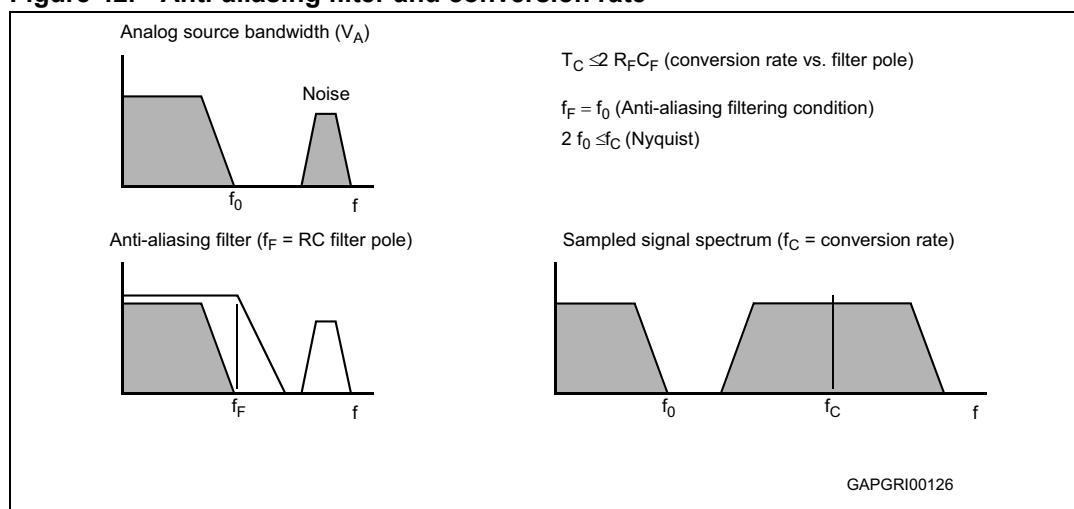
**Figure 42. Anti-aliasing filter and conversion rate**

The considerations above imposes new constraints on the external circuit, to reduce the accuracy error due to the voltage drop on  $C_S$ . From the two charge balance equations above, it is simple to derive the following relation between the ideal and real sampled voltage on  $C_S$ :

$$\frac{V_A}{V_{A2}} = \frac{C_{P1} + C_{P2} + C_F}{C_{P1} + C_{P2} + C_F + C_S}$$

From this formula, in the worst case (when  $V_A$  is maximum, that is for instance 5 V), assuming to accept a maximum error of half a count ( $\sim 2.44$  mV), a constraint is immediately evident on  $C_F$  value:

$$C_F > 2048 C_S$$

In the next section an example of how to design the external network is provided, assuming some reasonable values for the internal parameters and making a hypothesis on the characteristics of the analog signal to be sampled.

### Example of external network sizing

The following hypotheses are formulated in order to proceed in designing the external network on A/D converter input pins:

- Analog signal source bandwidth ( $f_0$ ): 10 kHz
- Conversion rate ( $f_C$ ): 25 kHz
- Sampling time ( $T_S$ ): 1  $\mu$ s
- Pin input capacitance ( $C_{P1}$ ): 5 pF
- Pin input routing capacitance ( $C_{P2}$ ): 1 pF
- Sampling capacitance ( $C_S$ ): 4 pF
- Maximum input current injection ( $I_{INJ}$ ): 3 mA
- Maximum analog source voltage ( $V_{AM}$ ): 12 V
- Analog source impedance ( $R_S$ ): 100  $\Omega$
- Channel switch resistance ( $R_{SW}$ ): 500  $\Omega$
- Sampling switch resistance ( $R_{AD}$ ): 200  $\Omega$

- Supposing a design of the filter, with the pole exactly at the maximum frequency of the signal, the time constant of the filter is:

$$R_C C_F = \frac{1}{2\pi f_0} = 15.9\mu\text{s}$$

- Using the relation between  $C_F$  and  $C_S$  and taking some margin (4000 instead of 2048), it is possible to define  $C_F$ :

$$C_F = 4000 C_S = 16\text{nF}$$

- As a consequence of step 1 and 2, RC can be chosen:

$$R_F = \frac{1}{2\pi f_0 C_F} = 995\Omega \cong 1\text{k}\Omega$$

- Considering the current injection limitation and supposing that the source can go up to 12 V, the total series resistance can be defined as:

$$R_S + R_F + R_L = \frac{V_{AM}}{I_{INJ}} = 4\text{k}\Omega$$

from which it is now simple to define the value of  $R_L$ :

$$R_L = \frac{V_{AM}}{I_{INJ}} - R_F - R_S = 2.9\text{k}\Omega$$

- Now the three elements of the external circuit  $R_F$ ,  $C_F$  and  $R_L$  are defined. Some conditions discussed in the previous paragraphs have been used to size the component, the other must now be verified. The relation which allows minimization of the accuracy error introduced by the switched capacitance equivalent resistance is in this case:

$$R_{EQ} = \frac{1}{f_C C_S} = 10\text{M}\Omega$$

So the error due to the voltage partitioning between the real resistive path and  $C_S$  is less than half a count (considering the worst case when  $V_A = 5\text{V}$ ):

$$V_A \cdot \frac{R_S + R_F + R_L + R_{SW} + R_{AD}}{R_{EQ}} = 2.35\text{mV} < \frac{1}{2}\text{LSB}$$

The other condition to be verified is if the time constants of the transients are really and significantly shorter than the sampling period duration  $T_S$ :

$$\tau_1 = (R_{SW} + R_{AD}) \cdot C_S = 2.8\text{ns} \ll T_S = 1\mu\text{s}$$

$$10 \tau_2 = 10 R_L (C_S + C_{P1} + C_{P2}) = 290\text{ns} < T_S = 1\mu\text{s}$$

For the complete set of parameters characterizing the ST10F272M A/D converter equivalent circuit, refer to [Section 24.7: A/D converter characteristics on page 131](#).

## 24.8 AC characteristics

### 24.8.1 Test waveforms

**Figure 43. Input/output waveforms**

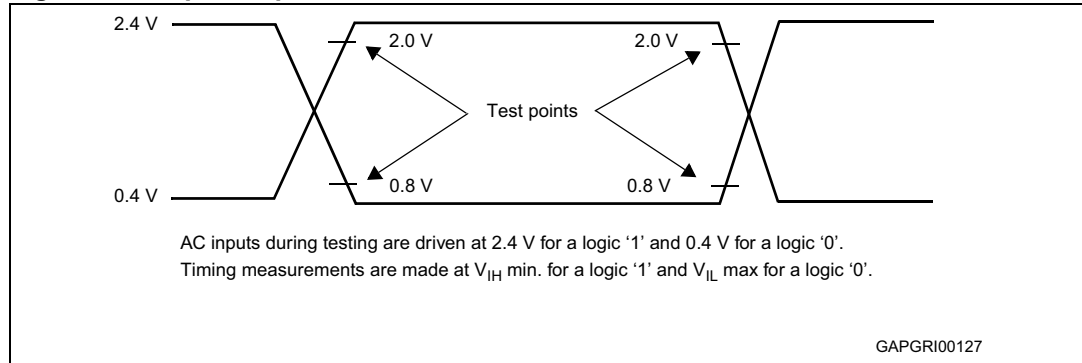

**Figure 44. Float waveforms**

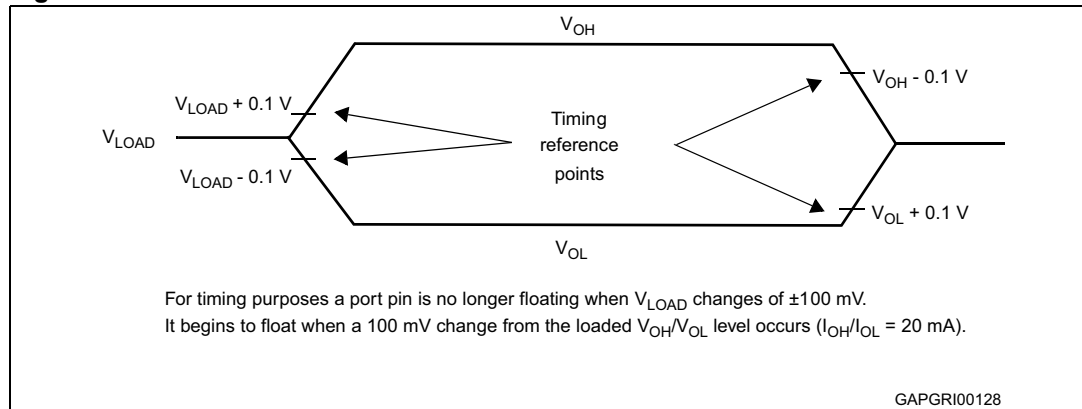

### 24.8.2 Definition of internal timing

The internal operation of the ST10F272M is controlled by the internal CPU clock  $f_{CPU}$ . Both edges of the CPU clock can trigger internal (for example, pipeline) or external (for example, bus cycles) operations.

The specification of the external timing (AC characteristics) therefore depends on the time between two consecutive edges of the CPU clock, called 'TCL'.

The CPU clock signal can be generated by different mechanisms. The duration of TCL and its variation (and also the derived external timing) depends on the mechanism used to generate  $f_{CPU}$ .

This influence must be regarded when calculating the timings for the ST10F272M.

The example for PLL operation shown in [Figure 45](#) refers to a PLL factor of 4.

The mechanism used to generate the CPU clock is selected during reset by the logic levels on pins P0.15-13 (POH.7-5).

Figure 45. Generation mechanisms for the CPU clock

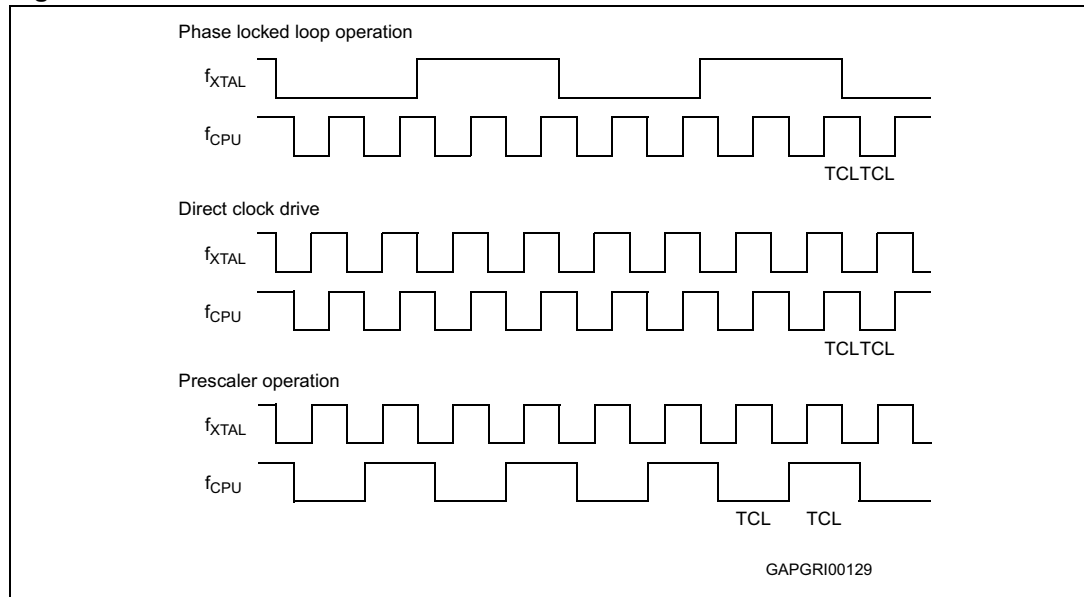

### 24.8.3 Clock generation modes

The next [Table 61](#) associates the combinations of these three bits with the respective clock generation mode.

Table 61. On-chip clock generator selections

P0.15-13 (POH.7-5)	CPU frequency $f_{CPU} = f_{XTAL} \times F$	External clock input range <sup>(1)(3)</sup>	Notes
1 1 1	$f_{XTAL} \times 4$	4 to 8 MHz	Default configuration
1 1 0	$f_{XTAL} \times 3$	5.3 to 8 MHz	
1 0 1	$f_{XTAL} \times 8$	4 to 5 MHz	
1 0 0	$f_{XTAL} \times 5$	6.4 to 8 MHz	
0 1 1	$f_{XTAL} \times 1$	1 to 40 MHz	Direct drive (oscillator bypassed) <sup>(2)</sup>
0 1 0	$f_{XTAL} \times 10$	4 MHz	
0 0 1	$f_{XTAL}/2$	4 to 8 MHz	CPU clock via prescaler <sup>(3)</sup>
0 0 0	-	-	Reserved

1. The external clock input range refers to a CPU clock range of 1...40 MHz. Moreover, the PLL usage is limited to 4-8 MHz. All configurations need a crystal (or ceramic resonator) to generate the CPU clock through the internal oscillator amplifier (apart from direct drive). Vice versa, the clock can be forced through an external clock source only in direct drive mode (on-chip oscillator amplifier disabled, so no crystal or resonator can be used).
2. The maximum depends on the duty cycle of the external clock signal. When 40 MHz is used, 50% duty cycle is granted (low phase = high phase = 12.5 ns); when 20 MHz is selected a 25 % duty cycle can be accepted (minimum phase, high or low, again equal to 12.5 ns).
3. The limits on input frequency are 4-8 MHz since the usage of the internal oscillator amplifier is required. Also when the PLL is not used and the CPU clock corresponds to  $f_{XTAL}/2$ , an external crystal or resonator must be used: It is not possible to force any clock through an external clock source.

### 24.8.4 Prescaler operation

When pins P0.15-13 (P0H.7-5) equal '001' during reset, the CPU clock is derived from the internal oscillator (input clock signal) by a 2:1 prescaler.

The frequency of  $f_{\text{CPU}}$  is half the frequency of  $f_{\text{XTAL}}$  and the high and low time of  $f_{\text{CPU}}$  (that is, the duration of an individual TCL) is defined by the period of the input clock  $f_{\text{XTAL}}$ .

The timings listed in the AC characteristics that refer to TCL therefore can be calculated using the period of  $f_{\text{XTAL}}$  for any TCL.

Note that if the bit OWDDIS in SYSCON register is cleared, the PLL runs on its free-running frequency and delivers the clock signal for the oscillator watchdog. If bit OWDDIS is set, then the PLL is switched off.

### 24.8.5 Direct drive

When pins P0.15-13 (P0H.7-5) equal '011' during reset the on-chip phase locked loop is disabled, the on-chip oscillator amplifier is bypassed and the CPU clock is directly driven by the input clock signal on XTAL1 pin.

The frequency of CPU clock ( $f_{\text{CPU}}$ ) directly follows the frequency of  $f_{\text{XTAL}}$  so the high and low time of  $f_{\text{CPU}}$  (that is, the duration of an individual TCL) is defined by the duty cycle of the input clock  $f_{\text{XTAL}}$ .

Therefore, the timings given in this chapter refer to the minimum TCL. This minimum value can be calculated by the following formula:

$$\text{TCL}_{\min} = 1/f_{\text{XTAL}} \times \text{DC}_{\min}$$

DC= duty cycle

For two consecutive TCLs, the deviation caused by the duty cycle of  $f_{\text{XTAL}}$  is compensated, so the duration of 2 TCL is always  $1/f_{\text{XTAL}}$ .

The minimum value  $\text{TCL}_{\min}$  has to be used only once for timings that require an odd number of TCLs (1,3,...). Timings that require an even number of TCLs (2,4,...) may use the formula:

$$2\text{TCL} = 1/f_{\text{XTAL}}$$

The address float timings in Multiplexed bus mode ( $t_{11}$  and  $t_{45}$ ) use the maximum duration of TCL ( $\text{TCL}_{\max} = 1/f_{\text{XTAL}} \times \text{DC}_{\max}$ ) instead of  $\text{TCL}_{\min}$ .

Similarly to what happen for prescaler operation, if the bit OWDDIS in SYSCON register is cleared, the PLL runs on its free-running frequency and delivers the clock signal for the oscillator watchdog. If bit OWDDIS is set, then the PLL is switched off.

### 24.8.6 Oscillator watchdog (OWD)

An on-chip watchdog oscillator is implemented in the ST10F272M. This feature is used for safety operation with external crystal oscillator (available only when using direct drive mode with or without prescaler, so the PLL is not used to generate the CPU clock multiplying the frequency of the external crystal oscillator). This watchdog oscillator operates as following.

The reset default configuration enables the watchdog oscillator. It can be disabled by setting the OWDDIS (bit 4) of SYSCON register.

When the OWD is enabled, the PLL runs at its free-running frequency, and it increments the watchdog counter. On each transition of external clock, the watchdog counter is cleared. If

an external clock failure occurs, then the watchdog counter overflows (after 16 PLL clock cycles).

The CPU clock signal will be switched to the PLL free-running clock signal, and the oscillator watchdog interrupt request is flagged. The CPU clock will not switch back to the external clock even if a valid external clock exists on XTAL1 pin. Only a hardware reset (or bidirectional software/watchdog reset) can switch the CPU clock source back to direct clock input.

When the OWD is disabled, the CPU clock is always the external oscillator clock (in direct drive or prescaler operation) and the PLL is switched off to decrease consumption supply current.

### 24.8.7 Phase locked loop (PLL)

For all other combinations of pins P0.15-13 (P0H.7-5) during reset the on-chip phase locked loop is enabled and it provides the CPU clock (see [Table 61](#)). The PLL multiplies the input frequency by the factor F which is selected via the combination of pins P0.15-13 ( $f_{\text{CPU}} = f_{\text{XTAL}} \times F$ ). With every F'th transition of  $f_{\text{XTAL}}$  the PLL circuit synchronizes the CPU clock to the input clock. This synchronization is done smoothly, so the CPU clock frequency does not change abruptly.

Due to this adaptation to the input clock the frequency of  $f_{\text{CPU}}$  is constantly adjusted so it is locked to  $f_{\text{XTAL}}$ . The slight variation causes a jitter of  $f_{\text{CPU}}$  which also effects the duration of individual TCLs.

The timings listed in the AC characteristics that refer to TCLs therefore must be calculated using the minimum TCL that is possible under the respective circumstances.

The real minimum value for TCL depends on the jitter of the PLL. The PLL tunes  $f_{\text{CPU}}$  to keep it locked on  $f_{\text{XTAL}}$ . The relative deviation of TCL is the maximum when it is referred to one TCL period.

This is especially important for bus cycles using wait states and for example, such as for the operation of timers or serial interfaces. For all slower operations and longer periods (for example, pulse train generation or measurement, or lower baudrates) the deviation caused by the PLL jitter is negligible. Refer to next [Section 24.8.9: PLL jitter](#) for more details.



### 24.8.8 Voltage controlled oscillator

The ST10F272M implements a PLL which combines different levels of frequency dividers with a voltage controlled oscillator (VCO) working as frequency multiplier. The following table gives a detailed summary of the internal settings and VCO frequency.

**Table 62. Internal PLL divider mechanism**

P0.15-13 (P0H.7-5)	XTAL frequency	Input prescaler	PLL		Output prescaler	CPU frequency $f_{\text{CPU}} = f_{\text{XTAL}} \times F$
			Multiply by	Divide by		
1 1 1	4 to 8 MHz	$f_{\text{XTAL}}/4$	64	4	–	$f_{\text{XTAL}} \times 4$
1 1 0	5.3 to 8 MHz <sup>(1)</sup>	$f_{\text{XTAL}}/4$	48	4	–	$f_{\text{XTAL}} \times 3$
1 0 1	4 to 5 MHz	$f_{\text{XTAL}}/4$	64	2	–	$f_{\text{XTAL}} \times 8$
1 0 0	6.4 to 8 MHz <sup>(1)</sup>	$f_{\text{XTAL}}/4$	40	2	–	$f_{\text{XTAL}} \times 5$
0 1 1	1 to 40 MHz	–	PLL bypassed		–	$f_{\text{XTAL}} \times 1$
0 1 0	4 MHz	$f_{\text{XTAL}}/2$	40	2	–	$f_{\text{XTAL}} \times 10$
0 0 1	4 to 8 MHz <sup>(1)</sup>	–	PLL bypassed		$f_{\text{PLL}}/2$	$f_{\text{XTAL}}/2$
0 0 0	–					

1. The PLL input frequency range is limited to 1 to 3.5 MHz, while the VCO oscillation range is 64 to 128 MHz. The CPU clock frequency range when PLL is used is 16 to 40 MHz.

#### Example 1

- $f_{\text{XTAL}} = 4$  MHz
- P0(15:13) = '110' (multiplication by 3)
- PLL input frequency = 1 MHz
- VCO frequency = 48 MHz: **NOT VALID**, must be 64 to 128 MHz
- $f_{\text{CPU}} = \mathbf{NOT\ VALID}$

#### Example 2

- $f_{\text{XTAL}} = 8$  MHz
- P0(15:13) = '100' (multiplication by 5)
- PLL input frequency = 2 MHz
- VCO frequency = 80 MHz
- PLL output frequency = 40 MHz (VCO frequency divided by 2)
- $f_{\text{CPU}} = 40$  MHz (no effect of output prescaler)

### 24.8.9 PLL jitter

The following terminology is defined below:

- **Self referred single period jitter**  
Also called 'period jitter', it can be defined as the difference of the  $T_{\max}$  and  $T_{\min}$ , where  $T_{\max}$  is maximum time period of the PLL output clock and  $T_{\min}$  is the minimum time period of the PLL output clock.
- **Self referred long term jitter**  
Also called 'N period jitter', it can be defined as the difference of  $T_{\max}$  and  $T_{\min}$ , where  $T_{\max}$  is the maximum time difference between N+1 clock rising edges and  $T_{\min}$  is the minimum time difference between N+1 clock rising edges. Here N should be kept sufficiently large to have the long term jitter. For N = 1, this becomes the single period jitter.

Jitter at the PLL output can be due to the following reasons:

- Jitter in the input clock
- Noise in the PLL loop

#### Jitter in the input clock

PLL acts like a low pass filter for any jitter in the input clock. Input clock jitter with the frequencies within the PLL loop bandwidth is passed to the PLL output and higher frequency jitter (frequency > PLL bandwidth) is attenuated @20dB/decade.

#### Noise in the PLL loop

This contribution again can be caused by the following sources:

- Device noise of the circuit in the PLL
- Noise in supply and substrate.

#### Device noise of the circuit in the PLL

The long term jitter is inversely proportional to the bandwidth of the PLL: the wider the loop bandwidth is, the lower the jitter is due to noise in the loop. Moreover, the long term jitter is practically independent of the multiplication factor.

The most noise sensitive circuit in the PLL circuit is definitively the VCO (voltage controlled oscillator). There are two main sources of noise: thermal (random noise, frequency-independent noise, thus, practically white noise) and flicker (low frequency noise,  $1/f$ ). For the frequency characteristics of the VCO circuitry, the effect of the thermal noise results in a  $1/f^2$  region in the output noise spectrum, while the flicker noise in a  $1/f^3$ . Assuming a noiseless PLL input and supposing that the VCO is dominated by its  $1/f^2$  noise, the RMS value of the accumulated jitter is proportional to the square root of N, where N is the number of clock periods within the considered time interval. On the contrary, assuming again a noiseless PLL input and supposing that the VCO is dominated by its  $1/f^3$  noise, the RMS value of the accumulated jitter is *proportional to N*, where N is the number of clock periods within the considered time interval.

The jitter in the PLL loop can be modeled as dominated by the  $1/f^2$  noise for N smaller than a certain value depending on the PLL output frequency and on the bandwidth characteristics of loop. Above this first value, the jitter becomes dominated by the  $1/f^3$  noise component. Lastly, for N greater than a second value of N, a saturation effect is evident, so the jitter does not grow anymore when considering a longer time interval (jitter stable increasing the number of clock periods N). The PLL loop acts as a high pass filter for any

noise in the loop, with cutoff frequency equal to the bandwidth of the PLL. The saturation value corresponds to what has been called self referred long term jitter of the PLL. In [Figure 46](#) the maximum jitter trend versus the number of clock periods N (for some typical CPU frequencies) is shown: The curves represent the very worst case, computed taking into account all corners of temperature, power supply and process variations: The real jitter is always measured well below the given worst case values.

### Noise in supply and substrate

Digital supply noise adds deterministic components to the PLL output jitter, independent of the multiplication factor. Its effects are strongly reduced thanks to the particular care used in the physical implementation and integration of the PLL module inside the device.

Nonetheless, the contribution of the digital noise to the global jitter is widely taken into account in the curves provided in [Figure 46](#).

**Figure 46. ST10F272M PLL jitter**

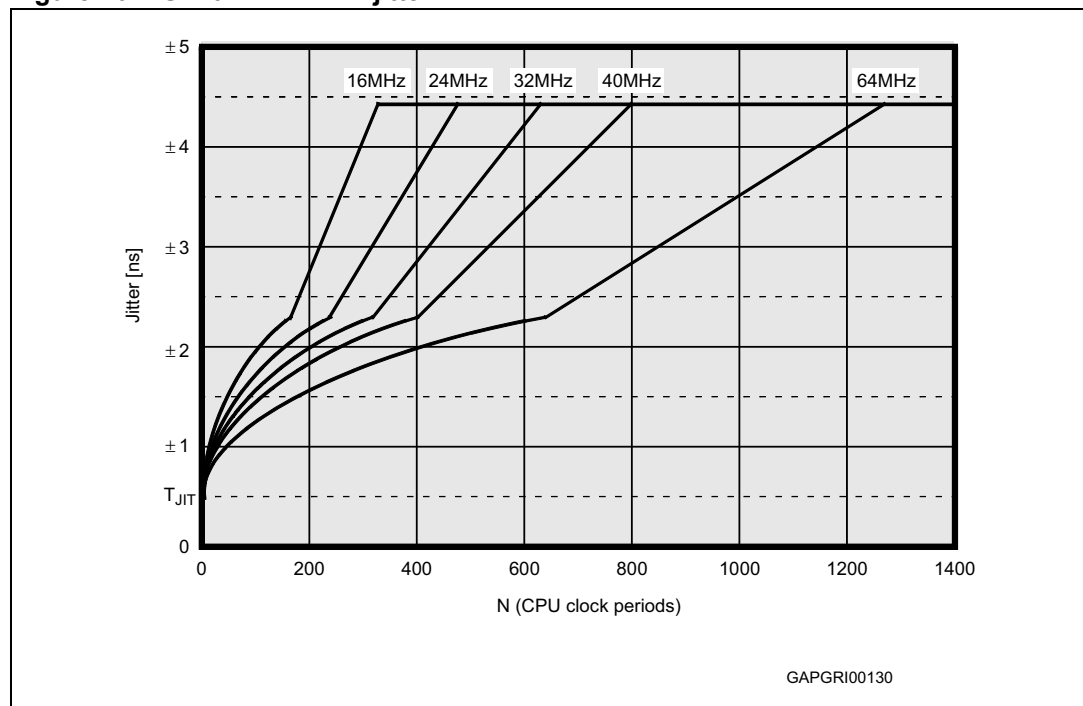

### 24.8.10 PLL lock/unlock

During normal operation, if the PLL gets unlocked for any reason, an interrupt request to the CPU is generated, and the reference clock (oscillator) is automatically disconnected from the PLL input: in this way, the PLL goes into free-running mode, providing the system with a backup clock signal (free running frequency  $f_{free}$ ). This feature allows recovery from a crystal failure occurrence without risking to go into an undefined configuration: The system is provided with a clock allowing the execution of the PLL unlock interrupt routine in a safe mode.

The path between reference clock and PLL input can be restored only by a hardware reset, or by a bidirectional software or watchdog reset event that forces the  $\overline{RSTIN}$  pin low.

*Note:* The external RC circuit on  $\overline{RSTIN}$  pin must be properly sized in order to extend the duration of the low pulse to lock the PLL before the level at  $\overline{RSTIN}$  pin is recognized high: A

bidirectional reset internally drives the  $\overline{RSTIN}$  pin low for just 1024 TCL (definitely not sufficient to lock the PLL starting from free-running mode).

**Table 63. PLL characteristics ( $V_{DD} = 5\text{ V} \pm 10\%$ ,  $V_{SS} = 0\text{ V}$ ,  $T_A = -40$  to  $+125\text{ }^\circ\text{C}$ )**

Symbol	Parameter	Conditions	Value		Unit
			Min	Max	
$t_{PSUP}$	PLL start-up time <sup>(1)</sup>	Stable $V_{DD}$ and reference clock	–	300	$\mu\text{s}$
$t_{LOCK}$	PLL lock-in time	Stable $V_{DD}$ and reference clock, starting from free-running mode	–	250	$\mu\text{s}$
$T_{JIT}$	Single period jitter <sup>(1)</sup> (cycle to cycle = 2 TCL)	6 sigma time period variation (peak to peak)	-500	+500	ps
$f_{free}$	PLL free running frequency	Multiplication factors: 3, 4	250	2000	kHz
		Multiplication factors: 5, 8, 10, 16	500	4000	

1. Not 100 % tested, guaranteed by design characterization

## 24.8.11 Main oscillator specifications

$V_{DD} = 5\text{ V} \pm 10\%$ ,  $V_{SS} = 0\text{ V}$ ,  $T_A = -40$  to  $+125\text{ }^\circ\text{C}$

**Table 64. Main oscillator characteristics**

Symbol	Parameter	Conditions	Value			Unit
			Min	Typ	Max	
$g_m$	Oscillator transconductance		1.4	2.6	4.2	mA/V
$V_{OSC}$	Oscillation amplitude <sup>(1)</sup>	Peak to peak	–	1.5	–	V
$V_{AV}$	Oscillation voltage level <sup>(1)</sup>	Sine wave middle	–	0.8	–	V
$t_{STUP}$	Oscillator start-up time <sup>(1)</sup>	Stable $V_{DD}$ - crystal	–	6	10	ms
		Stable $V_{DD}$ - resonator	–	1	2	ms

1. Not 100% tested, guaranteed by design characterization

Figure 47. Crystal oscillator and resonator connection diagram

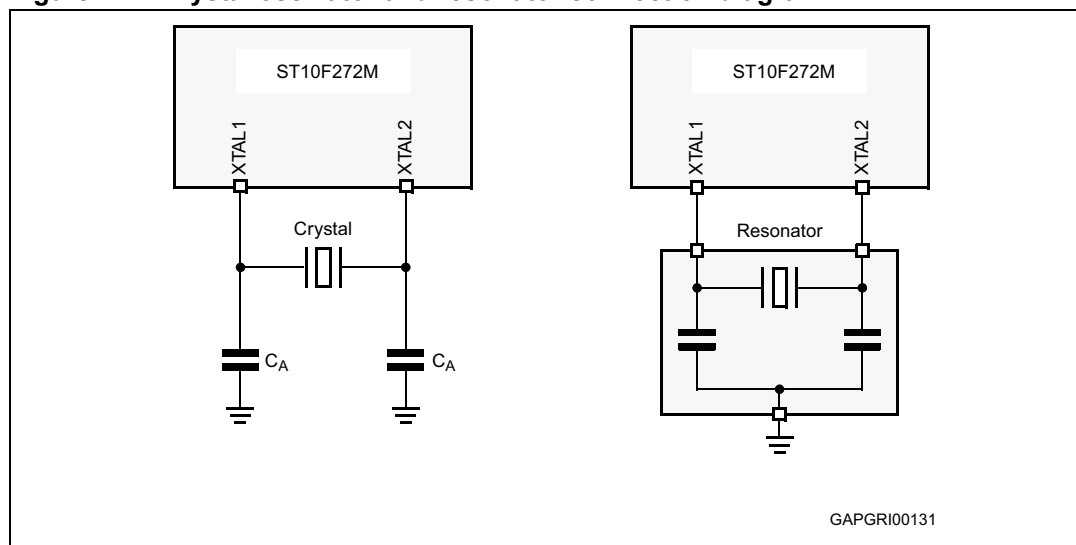

Table 65. Main oscillator negative resistance (module)

	$C_A = 15 \text{ pF}$			$C_A = 25 \text{ pF}$			$C_A = 35 \text{ pF}$		
	Min	Typ	Max	Min	Typ	Max	Min	Typ	Max
4 MHz	545 $\Omega$	1035 $\Omega$	–	550 $\Omega$	1050 $\Omega$	–	430 $\Omega$	850 $\Omega$	–
8 MHz	240 $\Omega$	450 $\Omega$	–	170 $\Omega$	350 $\Omega$	–	120 $\Omega$	250 $\Omega$	–

The given values of  $C_A$  do not include the stray capacitance of the package and of the printed circuit board: the negative resistance values are calculated assuming additional 5 pF to the values in the table. The crystal shunt capacitance ( $C_0$ ) and the package capacitance between XTAL1 and XTAL2 pins is globally assumed equal to 10 pF.

The external resistance between XTAL1 and XTAL2 is not necessary, since already present on the silicon.

### 24.8.12 32 kHz oscillator specifications

$V_{DD} = 5 \text{ V} \pm 10\%$ ,  $V_{SS} = 0 \text{ V}$ ,  $T_A = -40 \text{ to } +125 \text{ }^\circ\text{C}$

Table 66. 32 kHz oscillator characteristics

Symbol	Parameter	Conditions	Value			Unit
			Min	Typ	Max	
$g_{m32}$	Oscillator transconductance <sup>(1)</sup>	Startup	20	31	50	$\mu\text{A/V}$
		Normal run	8	17	30	$\mu\text{A/V}$
$V_{OSC32}$	Oscillation amplitude <sup>(2)</sup>	Peak to peak	0.5	1.0	2.4	V
$V_{AV32}$	Oscillation voltage level <sup>(2)</sup>	Sine wave middle	0.7	0.9	1.2	V
$t_{STUP32}$	Oscillator startup time <sup>(2)</sup>	Stable $V_{DD}$	–	1	5	s

1. At power-on a high current biasing is applied for faster oscillation start-up. Once the oscillation is started, the current biasing is reduced to lower the power consumption of the system.
2. Not 100% tested, guaranteed by design characterization.

**Figure 48. 32 kHz crystal oscillator connection diagram**

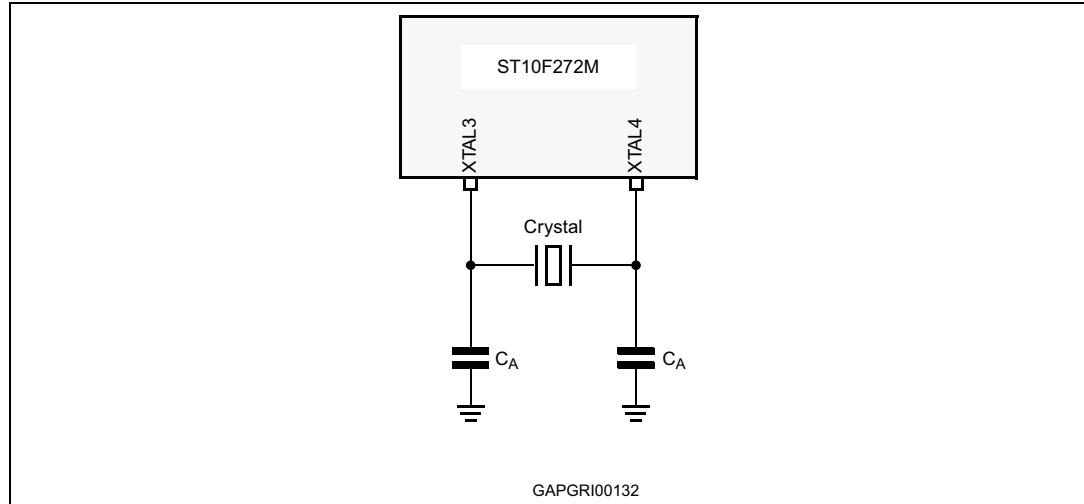

**Table 67. Minimum values of negative resistance (module) for 32 kHz oscillator**

Frequency	$C_A = 6 \text{ pF}$	$C_A = 12 \text{ pF}$	$C_A = 15 \text{ pF}$	$C_A = 18 \text{ pF}$	$C_A = 22 \text{ pF}$	$C_A = 27 \text{ pF}$	$C_A = 33 \text{ pF}$
32 kHz	-	-	-	-	150 kΩ	120 kΩ	90 kΩ

The given values of  $C_A$  do not include the stray capacitance of the package and of the printed circuit board: the negative resistance values are calculated assuming additional 5 pF to the values in the table. The crystal shunt capacitance ( $C_0$ ) and the package capacitance between XTAL3 and XTAL4 pins is globally assumed equal to 4 pF. The external resistance between XTAL3 and XTAL4 is not necessary, since already present on the silicon.

**Warning: Direct driving on XTAL3 pin is not supported. Always use a 32 kHz crystal oscillator.**

### 24.8.13 External clock drive XTAL1

When direct drive configuration is selected during reset, it is possible to drive the CPU clock directly from the XTAL1 pin, without particular restrictions on the maximum frequency, since the on-chip oscillator amplifier is bypassed. The speed limit is imposed by internal logic that targets a maximum CPU frequency of 40 MHz.

In all other clock configurations (direct drive with prescaler or PLL usage) the on-chip oscillator amplifier is not bypassed, so it determines the input clock speed limit. Then, when the on-chip oscillator is enabled it is forbidden to use any external clock source different from crystal or ceramic resonator.

**Table 68. External clock drive**

Parameter	Symbol		Direct drive $f_{CPU} = f_{XTAL}$		Direct drive with prescaler $f_{CPU} = f_{XTAL}/2$		PLL usage $f_{CPU} = f_{XTAL} \times F$		Unit
			Min	Max	Min	Max	Min	Max	
XTAL1 period <sup>(1)(2)</sup>	$t_{OSC}$	SR	25	–	83.3	250	83.3	250	ns
High time <sup>(3)</sup>	$t_1$	SR	6	–	3	–	6	–	ns
Low time <sup>(3)</sup>	$t_2$	SR	6	–	3	–	6	–	ns
Rise time <sup>(3)</sup>	$t_3$	SR	–	2	–	2	–	2	ns
Fall time <sup>(3)</sup>	$t_4$	SR	–	2	–	2	–	2	ns

1. The minimum value for the XTAL1 signal period is considered the theoretical minimum. The real minimum value depends on the duty cycle of the input clock signal.
2. 4 to 8 MHz is the input frequency range when using an external clock source. 40 MHz can be applied with an external clock source only when direct drive mode is selected: in this case, the oscillator amplifier is bypassed so it does not limit the input frequency.
3. The input clock signal must reach the defined levels  $V_{IL2}$  and  $V_{IH2}$ .

**Figure 49. External clock drive XTAL1**

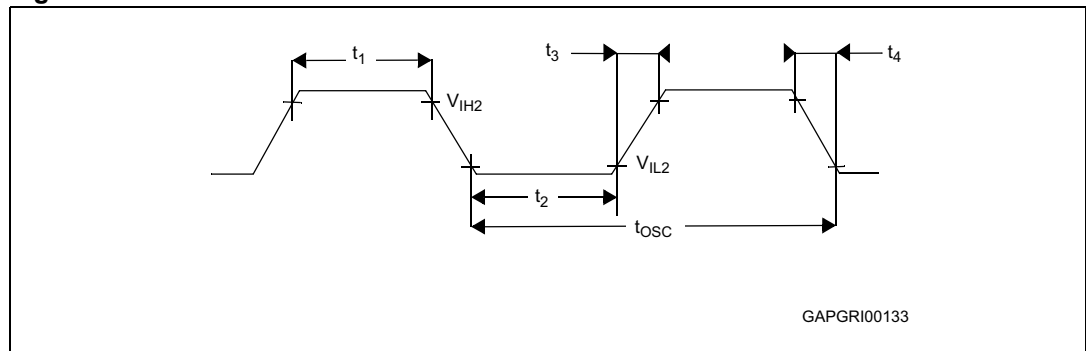

*Note:* When direct drive is selected, an external clock source can be used to drive XTAL1. The maximum frequency of the external clock source depends on the duty cycle: When 40 MHz is used, 50% duty cycle is granted (low phase = high phase = 12.5 ns); when for instance 20 MHz is used, a 25 % duty cycle can be accepted (minimum phase, high or low, again equal to 12.5 ns).

### 24.8.14 Memory cycle variables

The tables below use three variables which are derived from the BUSCONx registers and represent the special characteristics of the programmed memory cycle. The following table describes how these variables are to be computed.

**Table 69. Memory cycle variables**

Description	Symbol	Values
ALE extension	$t_A$	$TCL \times [ALECTL]$
Memory cycle time wait states	$t_C$	$2TCL \times (15 - [MCTC])$
Memory tri-state time	$t_F$	$2TCL \times (1 - [MTTC])$

### 24.8.15 External memory bus timing

The following sections include the external memory bus timings. The given values are computed for a maximum CPU clock of 40 MHz.

*Note:* All external memory bus timings and SSC timings listed in the following tables are granted by design characterization and not fully tested in production.



### 24.8.16 Multiplexed bus

$V_{DD} = 5\text{ V} \pm 10\%$ ,  $V_{SS} = 0\text{ V}$ ,  $T_A = -40\text{ to }+125\text{ }^\circ\text{C}$ ,  $CL = 50\text{ pF}$ ,  
 ALE cycle time =  $6\text{ TCL} + 2t_A + t_C + t_F$  (75 ns at 40 MHz CPU clock without wait states)

**Table 70. Multiplexed bus timings**

Symbol	Parameter	$f_{\text{CPU}} = 40\text{ MHz}$ $\text{TCL} = 12.5\text{ ns}$		Variable CPU clock $1/2\text{ TCL} = 1\text{ to }40\text{ MHz}$		Unit
		Min	Max	Min	Max	
$t_5$	CC ALE high time	$4 + t_A$	–	$\text{TCL} - 8.5 + t_A$	–	ns
$t_6$	CC Address setup to ALE	$1.5 + t_A$	–	$\text{TCL} - 11 + t_A$	–	ns
$t_7$	CC Address hold after ALE	$4 + t_A$	–	$\text{TCL} - 8.5 + t_A$	–	ns
$t_8$	tCC ALE falling edge to $\overline{\text{RD}}$ , $\overline{\text{WR}}$ (with RW-delay)	$4 + t_A$	–	$\text{TCL} - 8.5 + t_A$	–	ns
$t_9$	CC ALE falling edge to $\overline{\text{RD}}$ , $\overline{\text{WR}}$ (no RW-delay)	$-8.5 + t_A$	–	$-8.5 + t_A$	–	ns
$t_{10}$	CC Address float after $\overline{\text{RD}}$ , $\overline{\text{WR}}$ (with RW-delay)	–	6	–	6	ns
$t_{11}$	CC Address float after $\overline{\text{RD}}$ , $\overline{\text{WR}}$ (no RW-delay)	–	18.5	–	$\text{TCL} + 6$	ns
$t_{12}$	CC $\overline{\text{RD}}$ , $\overline{\text{WR}}$ low time (with RW-delay)	$15.5 + t_C$	–	$2\text{TCL} - 9.5 + t_C$	–	ns
$t_{13}$	CC $\overline{\text{RD}}$ , $\overline{\text{WR}}$ low time (no RW-delay)	$28 + t_C$	–	$3\text{TCL} - 9.5 + t_C$	–	ns
$t_{14}$	SR $\overline{\text{RD}}$ to valid data in (with RW-delay)	–	$6 + t_C$	–	$2\text{TCL} - 19 + t_C$	ns
$t_{15}$	SR $\overline{\text{RD}}$ to valid data in (no RW-delay)	–	$18.5 + t_C$	–	$3\text{TCL} - 19 + t_C$	ns
$t_{16}$	SR ALE low to valid data in	–	$17.5 + t_A + t_C$	–	$3\text{TCL} - 20 + t_A + t_C$	ns
$t_{17}$	SR Address/unlatched $\overline{\text{CS}}$ to valid data in	–	$20 + 2t_A + t_C$	–	$4\text{TCL} - 30 + 2t_A + t_C$	ns
$t_{18}$	SR Data hold after $\overline{\text{RD}}$ rising edge	0	–	0	–	ns
$t_{19}$	SR Data float after $\overline{\text{RD}}$	–	$16.5 + t_F$	–	$2\text{TCL} - 8.5 + t_F$	ns
$t_{22}$	CC Data valid to $\overline{\text{WR}}$	$10 + t_C$	–	$2\text{TCL} - 15 + t_C$	–	ns
$t_{23}$	CC Data hold after $\overline{\text{WR}}$	$4 + t_F$	–	$2\text{TCL} - 8.5 + t_F$	–	ns
$t_{25}$	CC ALE rising edge after $\overline{\text{RD}}$ , $\overline{\text{WR}}$	$15 + t_F$	–	$2\text{TCL} - 10 + t_F$	–	ns
$t_{27}$	CC Address/unlatched $\overline{\text{CS}}$ hold after $\overline{\text{RD}}$ , $\overline{\text{WR}}$	$10 + t_F$	–	$2\text{TCL} - 15 + t_F$	–	ns
$t_{38}$	CC ALE falling edge to latched $\overline{\text{CS}}$	$-4 - t_A$	$10 - t_A$	$-4 - t_A$	$10 - t_A$	ns
$t_{39}$	SR Latched $\overline{\text{CS}}$ low to valid data in	–	$16.5 + t_C + 2t_A$	–	$3\text{TCL} - 21 + t_C + 2t_A$	ns
$t_{40}$	CC Latched $\overline{\text{CS}}$ hold after $\overline{\text{RD}}$ , $\overline{\text{WR}}$	$27 + t_F$	–	$3\text{TCL} - 10.5 + t_F$	–	ns

Table 70. Multiplexed bus timings (continued)

Symbol	Parameter	$f_{CPU} = 40\text{ MHz}$ TCL = 12.5 ns		Variable CPU clock 1/2 TCL = 1 to 40 MHz		Unit
		Min	Max	Min	Max	
t <sub>42</sub>	CC ALE fall. edge to $\overline{RdCS}$ , $\overline{WrCS}$ (with RW delay)	$7 + t_A$	–	$TCL - 5.5 + t_A$	–	ns
t <sub>43</sub>	CC ALE fall. edge to $\overline{RdCS}$ , $\overline{WrCS}$ (no RW delay)	$-5.5 + t_A$	–	$-5.5 + t_A$	–	ns
t <sub>44</sub>	CC Address float after $\overline{RdCS}$ , $\overline{WrCS}$ (with RW delay)	–	1.5	–	1.5	ns
t <sub>45</sub>	CC Address float after $\overline{RdCS}$ , $\overline{WrCS}$ (no RW delay)	–	14	–	$TCL + 1.5$	ns
t <sub>46</sub>	SR $\overline{RdCS}$ to valid data In (with RW delay)	–	$4 + t_C$	–	$2TCL - 21 + t_C$	ns
t <sub>47</sub>	SR $\overline{RdCS}$ to Valid Data In (no RW delay)	–	$16.5 + t_C$	–	$3TCL - 21 + t_C$	ns
t <sub>48</sub>	CC $\overline{RdCS}$ , $\overline{WrCS}$ low time (with RW delay)	$15.5 + t_C$	–	$2TCL - 9.5 + t_C$	–	ns
t <sub>49</sub>	CC $\overline{RdCS}$ , $\overline{WrCS}$ low time (no RW delay)	$28 + t_C$	–	$3TCL - 9.5 + t_C$	–	ns
t <sub>50</sub>	CC Data valid to $\overline{WrCS}$	$10 + t_C$	–	$2TCL - 15 + t_C$	–	ns
t <sub>51</sub>	SR Data hold after $\overline{RdCS}$	0	–	0	–	ns
t <sub>52</sub>	SR Data float after $\overline{RdCS}$	–	$16.5 + t_F$	–	$2TCL - 8.5 + t_F$	ns
t <sub>54</sub>	CC Address hold after $\overline{RdCS}$ , $\overline{WrCS}$	$6 + t_F$	–	$2TCL - 19 + t_F$	–	ns
t <sub>56</sub>	CC Data hold after $\overline{WrCS}$	$6 + t_F$	–	$2TCL - 19 + t_F$	–	ns

Figure 50. External memory cycle: Multiplexed bus, with/without read/write delay, normal ALE

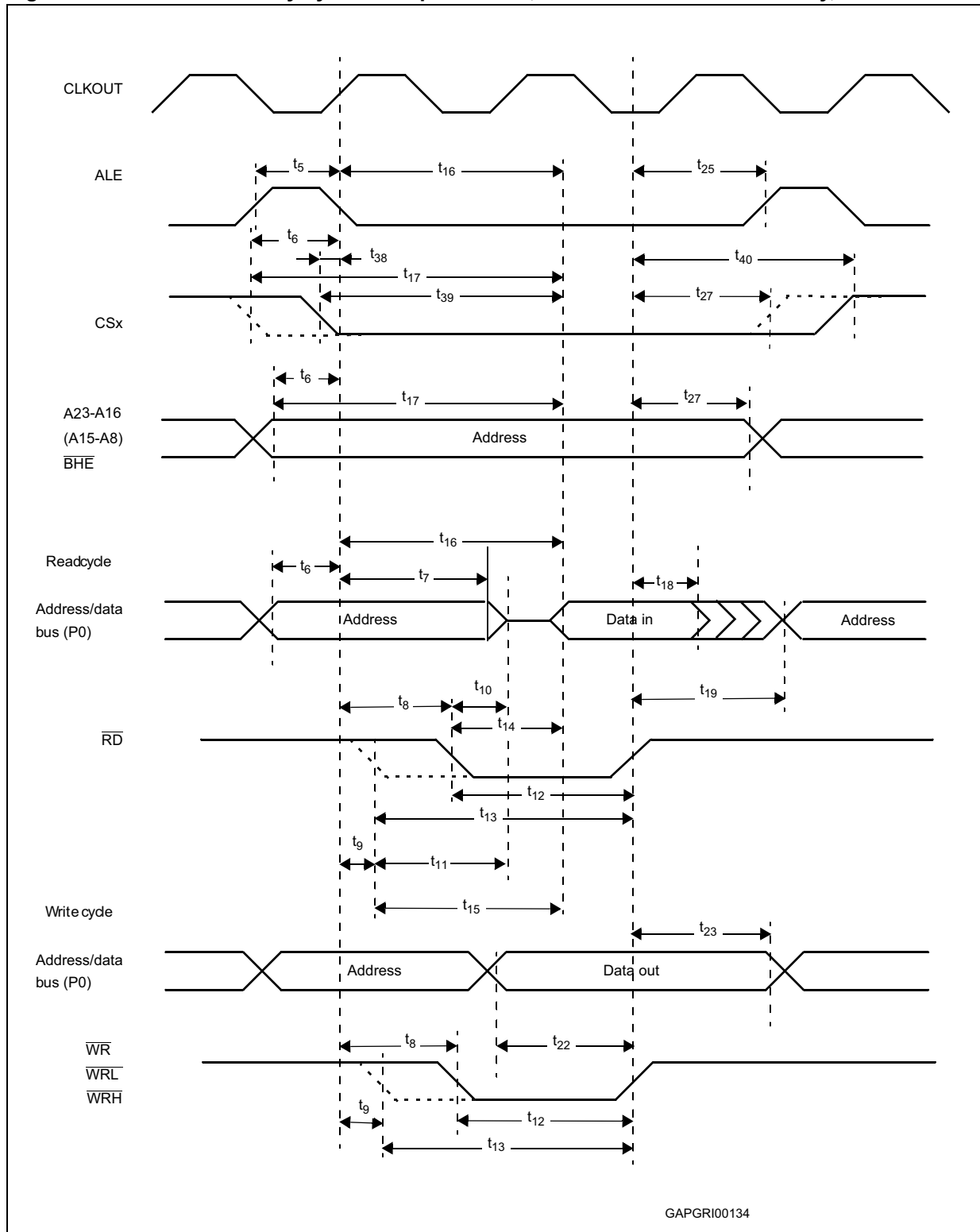

Figure 51. External memory cycle: Multiplexed bus, with/without read/write delay, extended ALE

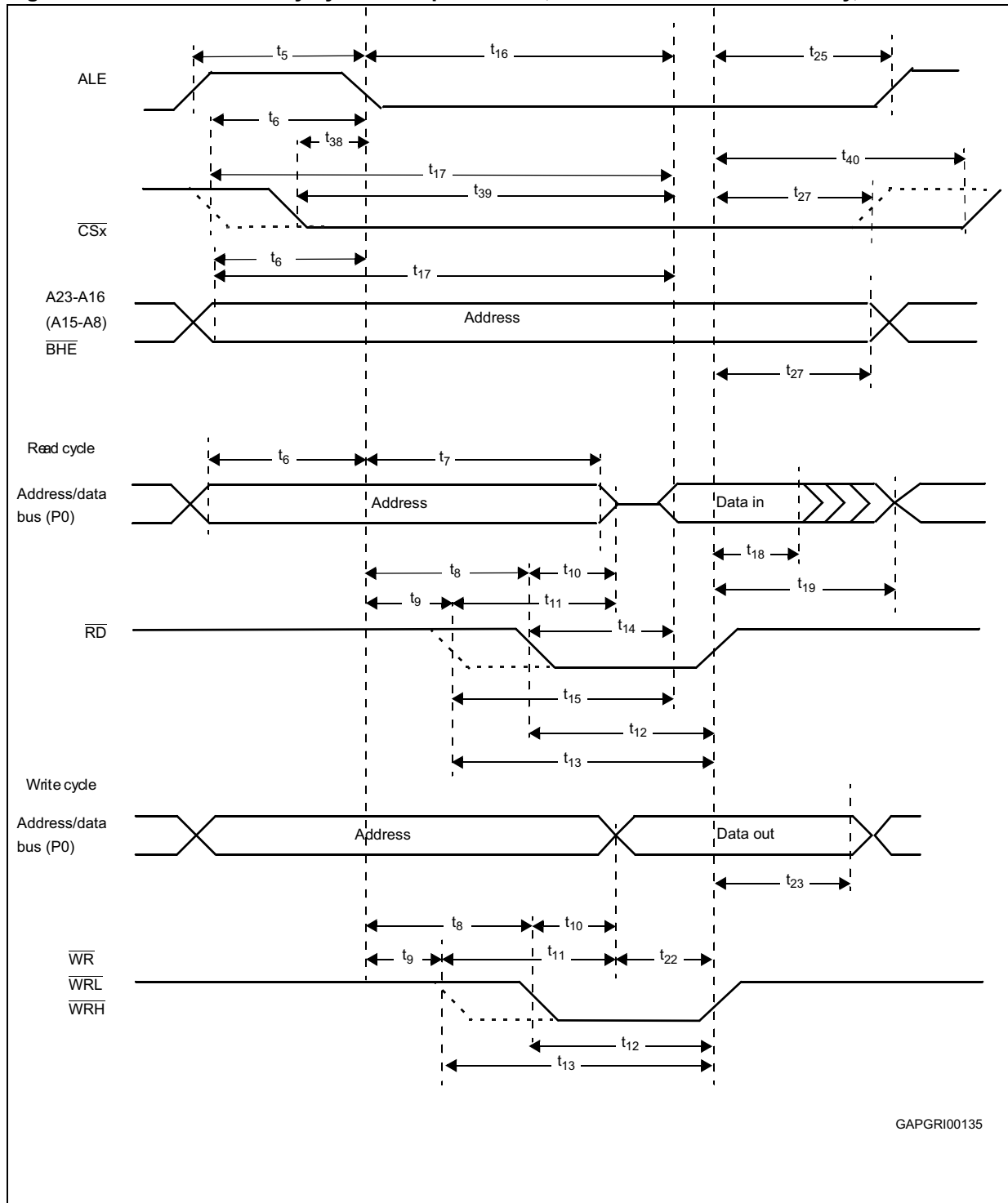

Figure 52. External memory cycle: Multiplexed bus, with/without r/w delay, normal ALE, r/w CS

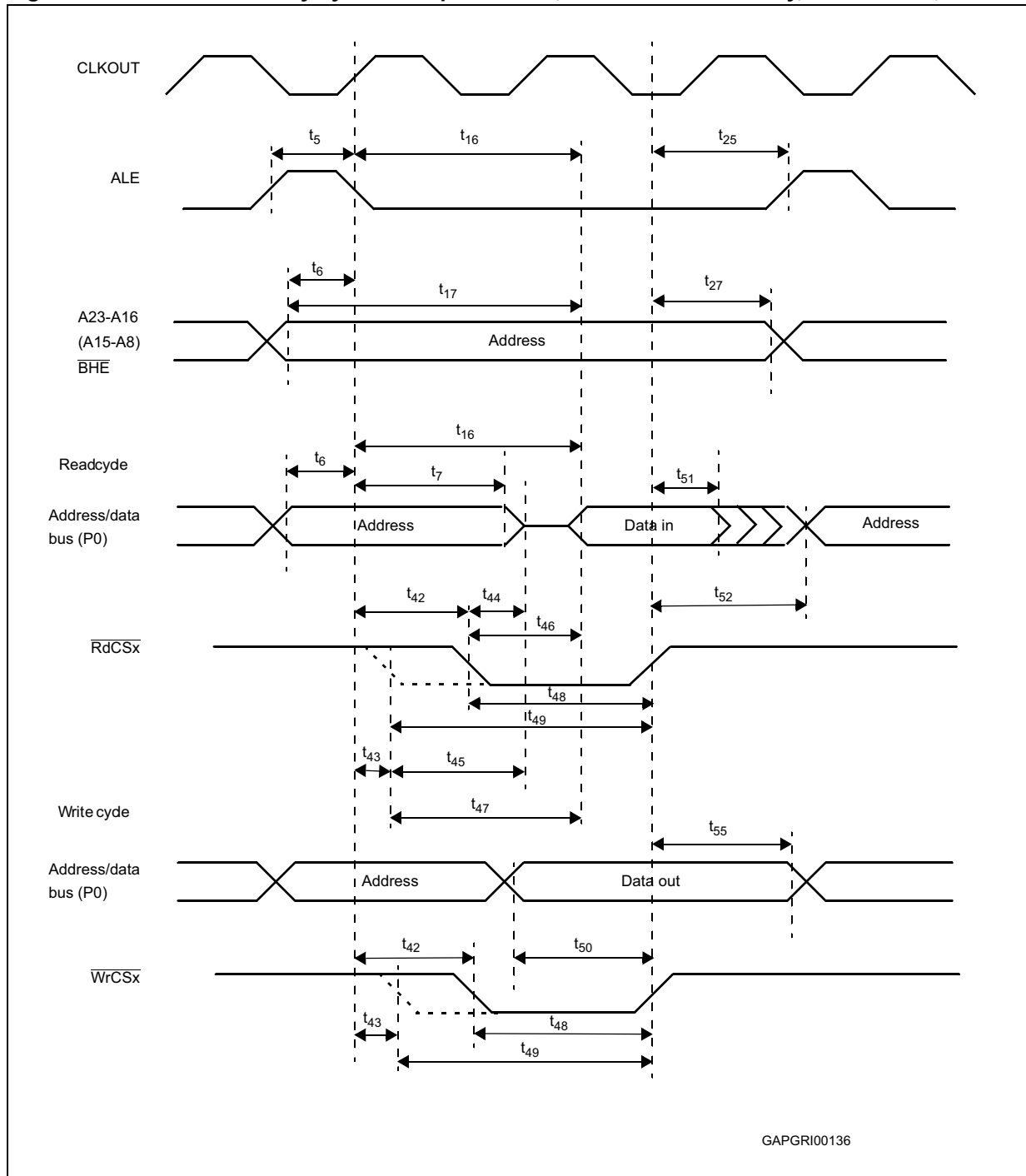
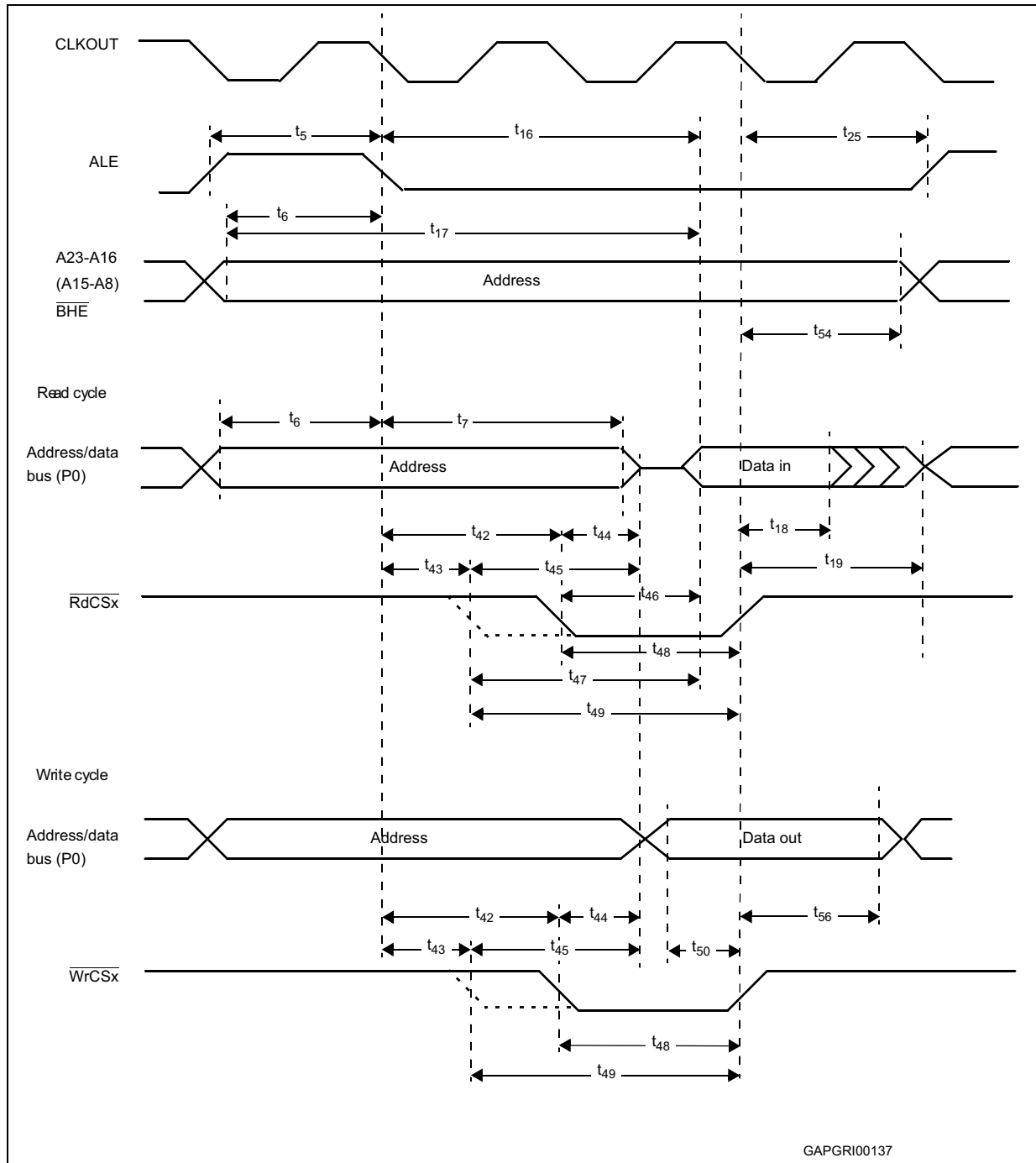

Figure 53. External memory cycle: Multiplexed bus, with/without r/w delay, extended ALE, r/w CS



### 24.8.17 Demultiplexed bus

$V_{DD} = 5\text{ V} \pm 10\%$ ,  $V_{SS} = 0\text{ V}$ ,  $T_A = -40\text{ to }+125\text{ }^\circ\text{C}$ ,  $CL = 50\text{ pF}$ ,  
 ALE cycle time =  $4\text{ TCL} + 2\text{ t}_A + \text{t}_C + \text{t}_F$  (50 ns at 40 MHz CPU clock without wait states).

**Table 71. Demultiplexed bus timings**

Symbol	Parameter	$f_{\text{CPU}} = 40\text{ MHz}$ $\text{TCL} = 12.5\text{ ns}$		Variable CPU clock $1/2\text{ TCL} = 1\text{ to }40\text{ MHz}$		Unit
		Min	Max	Min	Max	
$t_5$	CC ALE high time	$4 + t_A$	–	$\text{TCL} - 8.5 + t_A$	–	ns
$t_6$	CC Address setup to ALE	$1.5 + t_A$	–	$\text{TCL} - 11 + t_A$	–	ns
$t_{80}$	CC Address/Unlatched $\overline{\text{CS}}$ setup to $\overline{\text{RD}}$ , $\overline{\text{WR}}$ (with RW-delay)	$12.5 + 2t_A$	–	$2\text{TCL} - 12.5 + 2t_A$	–	ns
$t_{81}$	CC Address/Unlatched $\overline{\text{CS}}$ setup to $\overline{\text{RD}}$ , $\overline{\text{WR}}$ (no RW-delay)	$0.5 + 2t_A$	–	$\text{TCL} - 12 + 2t_A$	–	ns
$t_{12}$	CC $\overline{\text{RD}}$ , $\overline{\text{WR}}$ low time (with RW-delay)	$15.5 + t_C$	–	$2\text{TCL} - 9.5 + t_C$	–	ns
$t_{13}$	CC $\overline{\text{RD}}$ , $\overline{\text{WR}}$ low time (no RW-delay)	$28 + t_C$	–	$3\text{TCL} - 9.5 + t_C$	–	ns
$t_{14}$	SR $\overline{\text{RD}}$ to valid data in (with RW-delay)	–	$6 + t_C$	–	$2\text{TCL} - 19 + t_C$	ns
$t_{15}$	SR $\overline{\text{RD}}$ to valid data in (no RW-delay)	–	$18.5 + t_C$	–	$3\text{TCL} - 19 + t_C$	ns
$t_{16}$	SR ALE low to valid data in	–	$17.5 + t_A + t_C$	–	$3\text{TCL} - 20 + t_A + t_C$	ns
$t_{17}$	SR Address/Unlatched $\overline{\text{CS}}$ to valid data in	–	$20 + 2t_A + t_C$	–	$4\text{TCL} - 30 + 2t_A + t_C$	ns
$t_{18}$	SR Data hold after $\overline{\text{RD}}$ rising edge	0	–	0	–	ns
$t_{20}$	SR Data float after $\overline{\text{RD}}$ rising edge (with RW-delay) <sup>(1)</sup>	–	$16.5 + t_F$	–	$2\text{TCL} - 8.5 + t_F + 2t_A$	ns
$t_{21}$	SR Data float after $\overline{\text{RD}}$ rising edge (no RW-delay) <sup>(1)</sup>	–	$4 + t_F$	–	$\text{TCL} - 8.5 + t_F + 2t_A$	ns
$t_{22}$	CC Data valid to $\overline{\text{WR}}$	$10 + t_C$	–	$2\text{TCL} - 15 + t_C$	–	ns
$t_{24}$	CC Data hold after $\overline{\text{WR}}$	$4 + t_F$	–	$\text{TCL} - 8.5 + t_F$	–	ns
$t_{26}$	CC ALE rising edge after $\overline{\text{RD}}$ , $\overline{\text{WR}}$	$-10 + t_F$	–	$-10 + t_F$	–	ns
$t_{28}$	CC Address/unlatched $\overline{\text{CS}}$ hold after $\overline{\text{RD}}$ , $\overline{\text{WR}}$ <sup>(2)</sup>	$0 + t_F$	–	$0 + t_F$	–	ns
$t_{28h}$	CC Address/unlatched $\overline{\text{CS}}$ hold after $\overline{\text{WRH}}$	$-5 + t_F$	–	$-5 + t_F$	–	ns
$t_{38}$	CC ALE falling edge to latched $\overline{\text{CS}}$	$-4 - t_A$	$6 - t_A$	$-4 - t_A$	$6 - t_A$	ns
$t_{39}$	SR Latched $\overline{\text{CS}}$ low to valid data in	–	$16.5 + t_C + 2t_A$	–	$3\text{TCL} - 21 + t_C + 2t_A$	ns

Table 71. Demultiplexed bus timings (continued)

Symbol	Parameter	f <sub>CPU</sub> = 40 MHz TCL = 12.5 ns		Variable CPU clock 1/2 TCL = 1 to 40 MHz		Unit	
		Min	Max	Min	Max		
t <sub>41</sub>	CC	Latched $\overline{CS}$ hold after $\overline{RD}$ , $\overline{WR}$	2 + t <sub>F</sub>	–	TCL - 10.5 + t <sub>F</sub>	–	ns
t <sub>82</sub>	CC	Address setup to $\overline{RdCS}$ , $\overline{WrCS}$ (with RW-delay)	14 + 2t <sub>A</sub>	–	2TCL - 11 + 2t <sub>A</sub>	–	ns
t <sub>83</sub>	CC	Address setup to $\overline{RdCS}$ , $\overline{WrCS}$ (no RW-delay)	2 + 2t <sub>A</sub>	–	TCL - 10.5 + 2 t <sub>A</sub>	–	ns
t <sub>46</sub>	SR	$\overline{RdCS}$ to valid data in (with RW-delay)	–	4 + t <sub>C</sub>	–	2TCL - 21 + t <sub>C</sub>	ns
t <sub>47</sub>	SR	$\overline{RdCS}$ to valid data in (no RW-delay)	–	16.5 + t <sub>C</sub>	–	3TCL - 21 + t <sub>C</sub>	ns
t <sub>48</sub>	CC	$\overline{RdCS}$ , $\overline{WrCS}$ low time (with RW-delay)	15.5 + t <sub>C</sub>	–	2TCL - 9.5 + t <sub>C</sub>	–	ns
t <sub>49</sub>	CC	$\overline{RdCS}$ , $\overline{WrCS}$ low time (no RW-delay)	28 + t <sub>C</sub>	–	3TCL - 9.5 + t <sub>C</sub>	–	ns
t <sub>50</sub>	CC	Data valid to $\overline{WrCS}$	10 + t <sub>C</sub>	–	2TCL - 15 + t <sub>C</sub>	–	ns
t <sub>51</sub>	SR	Data hold after $\overline{RdCS}$	0	–	0	–	ns
t <sub>53</sub>	SR	Data float after $\overline{RdCS}$ (with RW-delay) <sup>(3)</sup>	–	16.5 + t <sub>F</sub>	–	2TCL - 8.5 + t <sub>F</sub>	ns
t <sub>68</sub>	SR	Data float after $\overline{RdCS}$ (no RW-delay) <sup>(3)</sup>	–	4 + t <sub>F</sub>	–	TCL - 8.5 + t <sub>F</sub>	ns
t <sub>55</sub>	CC	Address hold after $\overline{RdCS}$ , $\overline{WrCS}$	-8.5 + t <sub>F</sub>	–	-8.5 + t <sub>F</sub>	–	ns
t <sub>57</sub>	CC	Data hold after $\overline{WrCS}$	2 + t <sub>F</sub>	–	TCL - 10.5 + t <sub>F</sub>	–	ns

1. RW-delay and t<sub>A</sub> refer to the next following bus cycle.
2. Read data is latched with the same clock edge that triggers the address change and the rising  $\overline{RD}$  edge. Therefore address changes before the end of  $\overline{RD}$  have no impact on read cycles.
3. Partially tested, guaranteed by design characterization.



Figure 54. External memory cycle: Demultiplexed bus, with/without r/w delay, normal ALE

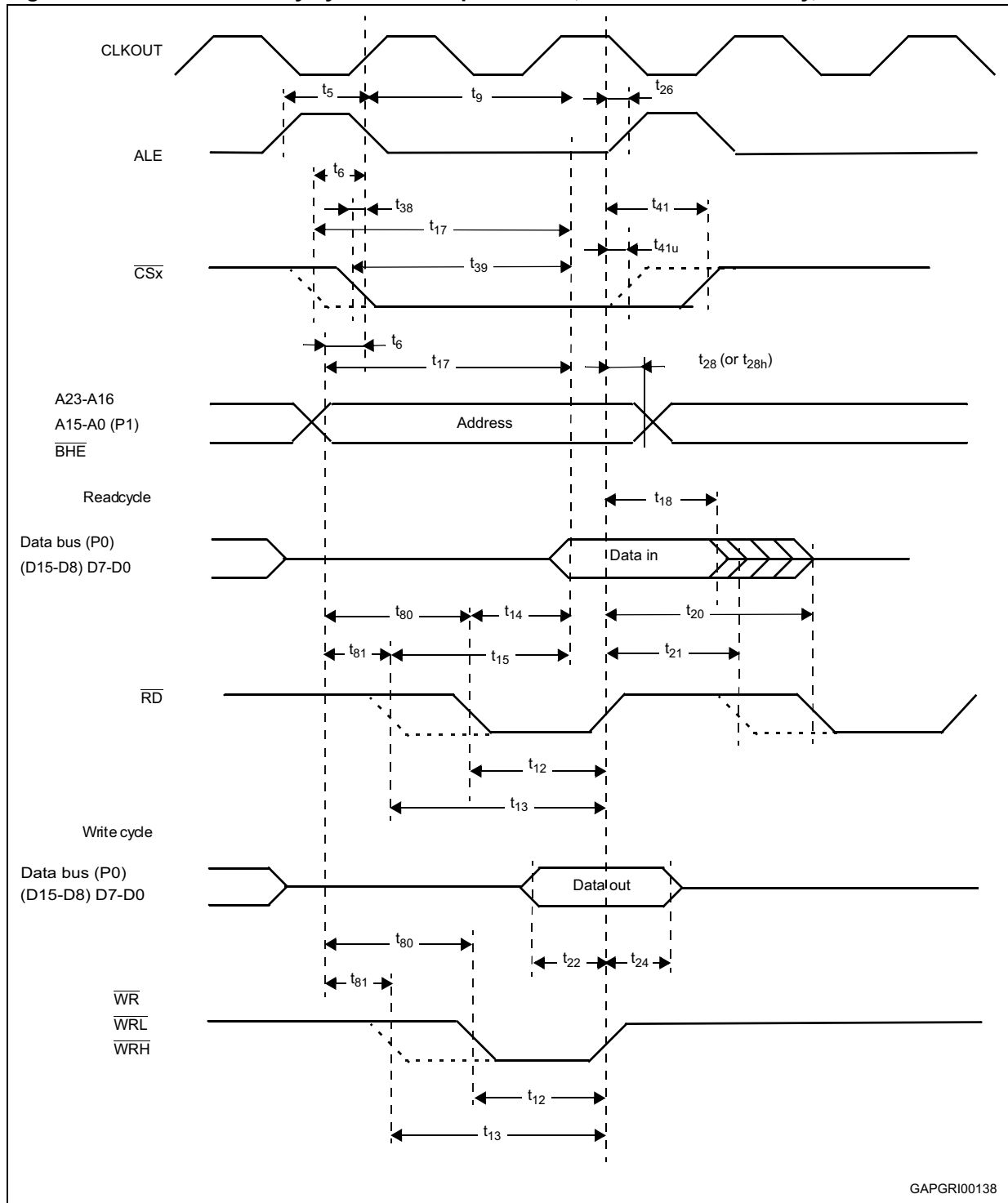

Figure 55. External memory cycle: Demultiplexed bus, with/without r/w delay, extended ALE

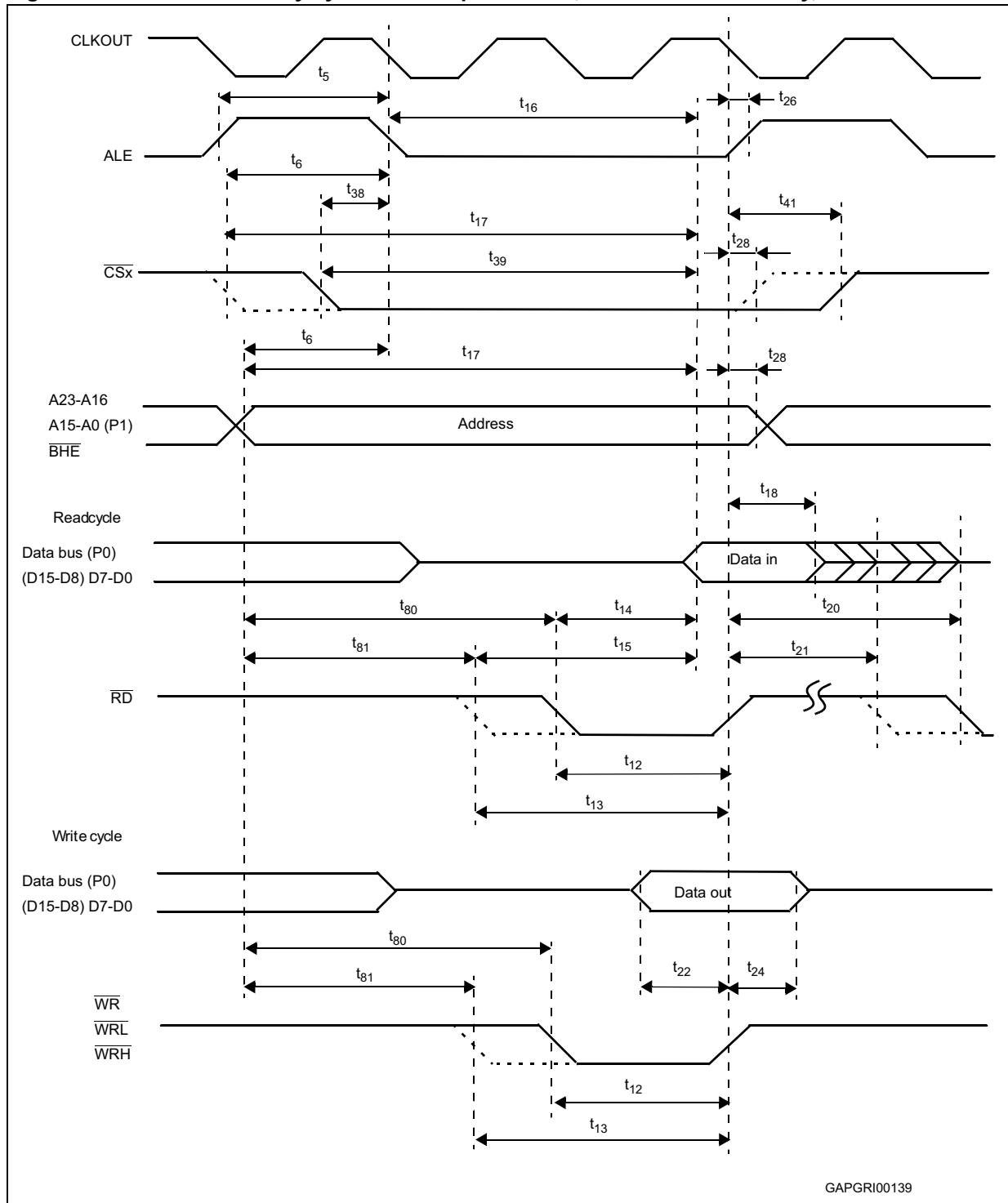

Figure 56. External memory cycle: Demultipl. bus, with/without r/w delay, normal ALE, r/w CS

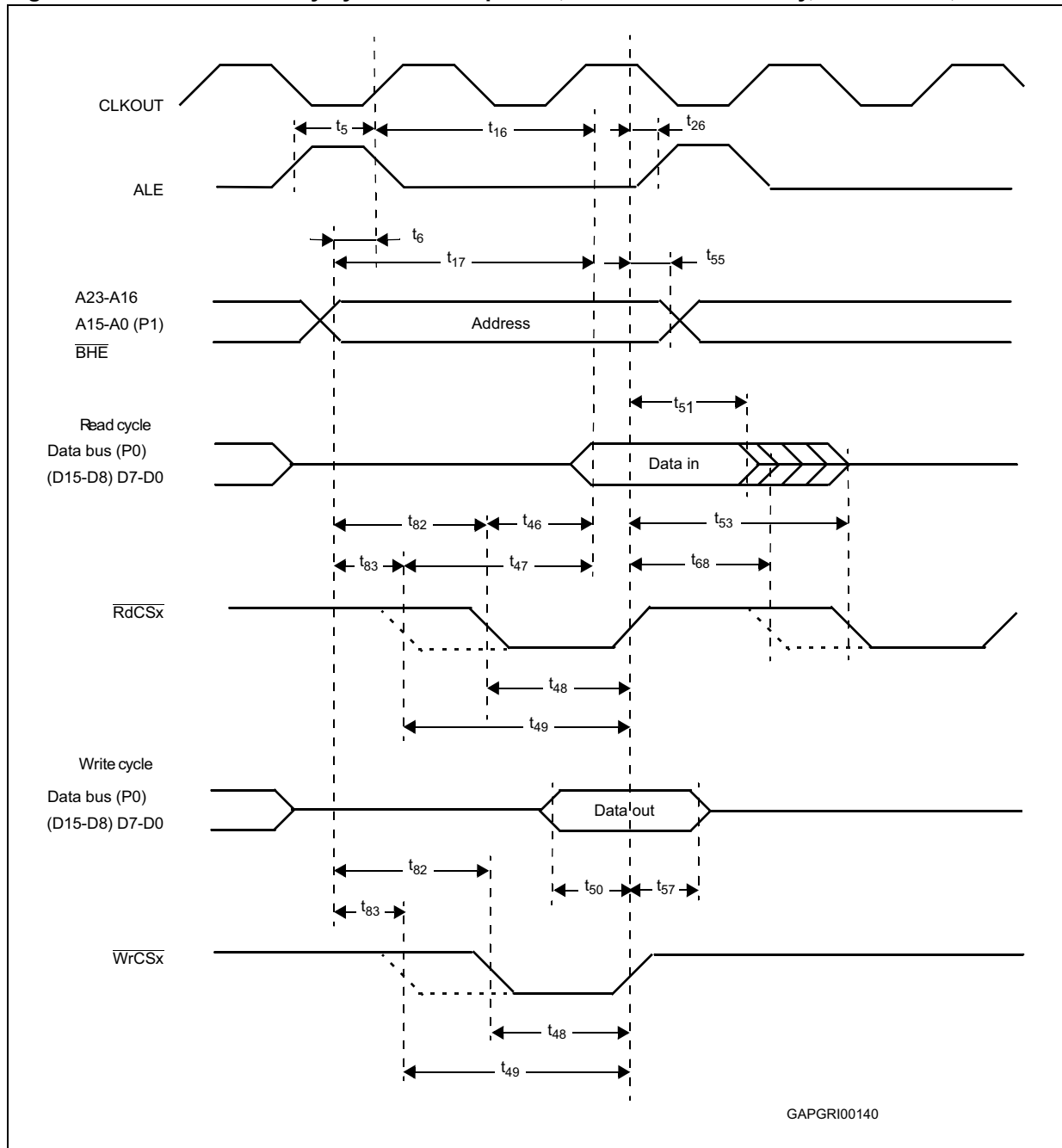
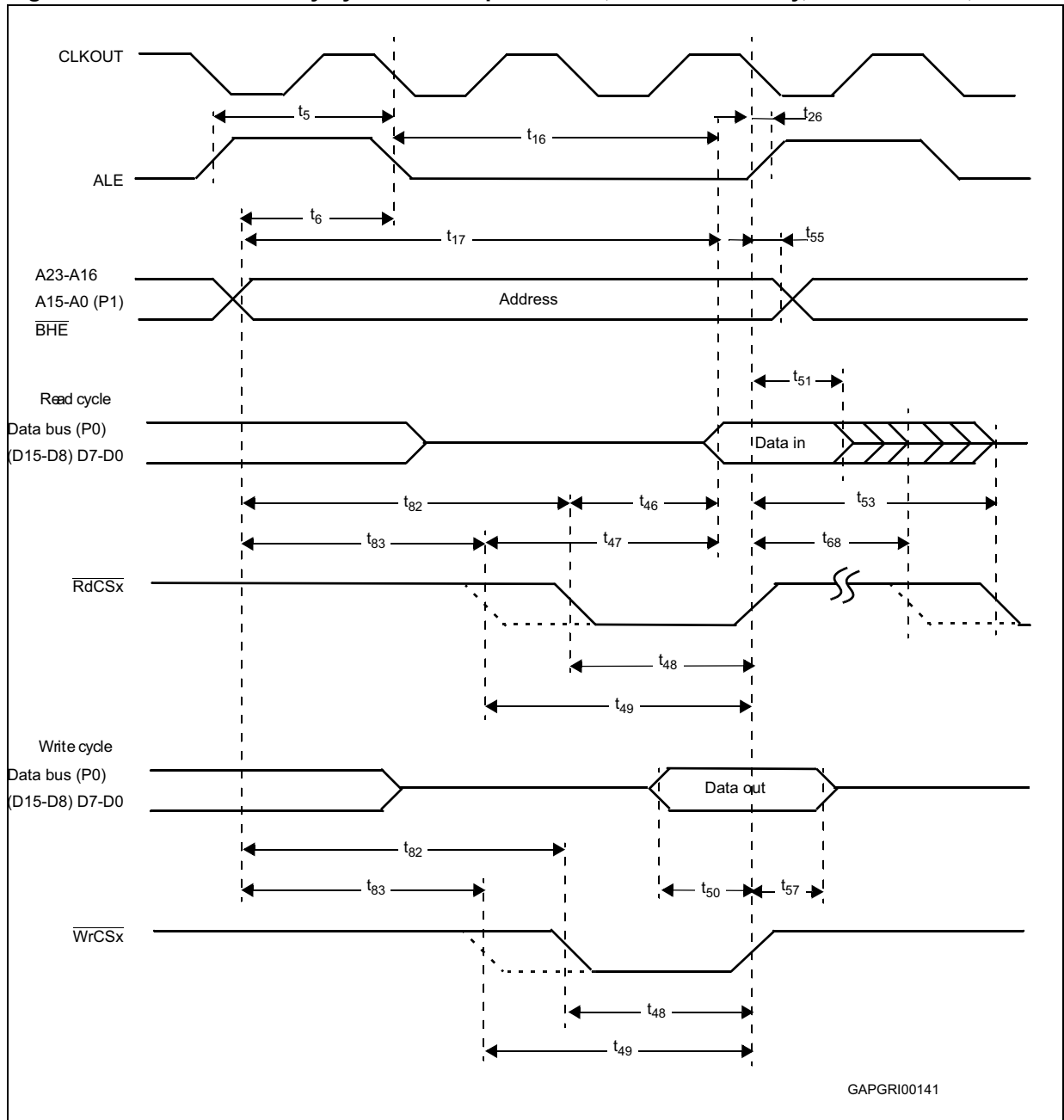

Figure 57. External memory cycle: Demultiplexed bus, without r/w delay, extended ALE, r/w CS



### 24.8.18 CLKOUT and $\overline{\text{READY}}$

$V_{DD} = 5\text{ V} \pm 10\%$ ,  $V_{SS} = 0\text{ V}$ ,  $T_A = -40\text{ to } +125\text{ }^\circ\text{C}$ ,  $CL = 50\text{ pF}$

**Table 72. CLKOUT and  $\overline{\text{READY}}$  timings**

Symbol		Parameter	$f_{\text{CPU}} = 40\text{ MHz}$ TCL = 12.5ns		Variable CPU clock 1/2 TCL = 1 to 40 MHz		Unit
			Min	Max	Min	Max	
t <sub>29</sub>	CC	CLKOUT cycle time	25	25	2TCL	2TCL	ns
t <sub>30</sub>	CC	CLKOUT high time	9	–	TCL - 3.5	–	ns
t <sub>31</sub>	CC	CLKOUT low time	10	–	TCL - 2.5	–	ns
t <sub>32</sub>	CC	CLKOUT rise time	–	4	–	4	ns
t <sub>33</sub>	CC	CLKOUT fall time	–	4	–	4	ns
t <sub>34</sub>	CC	CLKOUT rising edge to ALE falling edge	-2 + t <sub>A</sub>	8 + t <sub>A</sub>	-2 + t <sub>A</sub>	8 + t <sub>A</sub>	ns
t <sub>35</sub>	SR	Synchronous $\overline{\text{READY}}$ setup time to CLKOUT	17	–	17	–	ns
t <sub>36</sub>	SR	Synchronous $\overline{\text{READY}}$ hold time after CLKOUT	2	–	2	–	ns
t <sub>37</sub>	SR	Asynchronous $\overline{\text{READY}}$ low time	35	–	2TCL + 10	–	ns
t <sub>58</sub>	SR	Asynchronous $\overline{\text{READY}}$ setup time <sup>(1)</sup>	17	–	17	–	ns
t <sub>59</sub>	SR	Asynchronous $\overline{\text{READY}}$ hold time <sup>(1)</sup>	2	–	2	–	ns
t <sub>60</sub>	SR	Asynchronous $\overline{\text{READY}}$ hold time after $\overline{\text{RD}}$ , $\overline{\text{WR}}$ high (demultiplexed Bus) <sup>(2)</sup>	0	2t <sub>A</sub> + t <sub>C</sub> + t <sub>F</sub>	0	2t <sub>A</sub> + t <sub>C</sub> + t <sub>F</sub>	ns

1. These timings are given for characterization purposes only, in order to assure recognition at a specific clock edge.
2. Demultiplexed bus is the worst case. For multiplexed bus 2 TCL are to be added to the maximum values. This adds even more time for deactivating  $\overline{\text{READY}}$ . 2t<sub>A</sub> and t<sub>C</sub> refer to the next following bus cycle, t<sub>F</sub> refers to the current bus cycle.

Figure 58. CLKOUT and  $\overline{\text{READY}}$

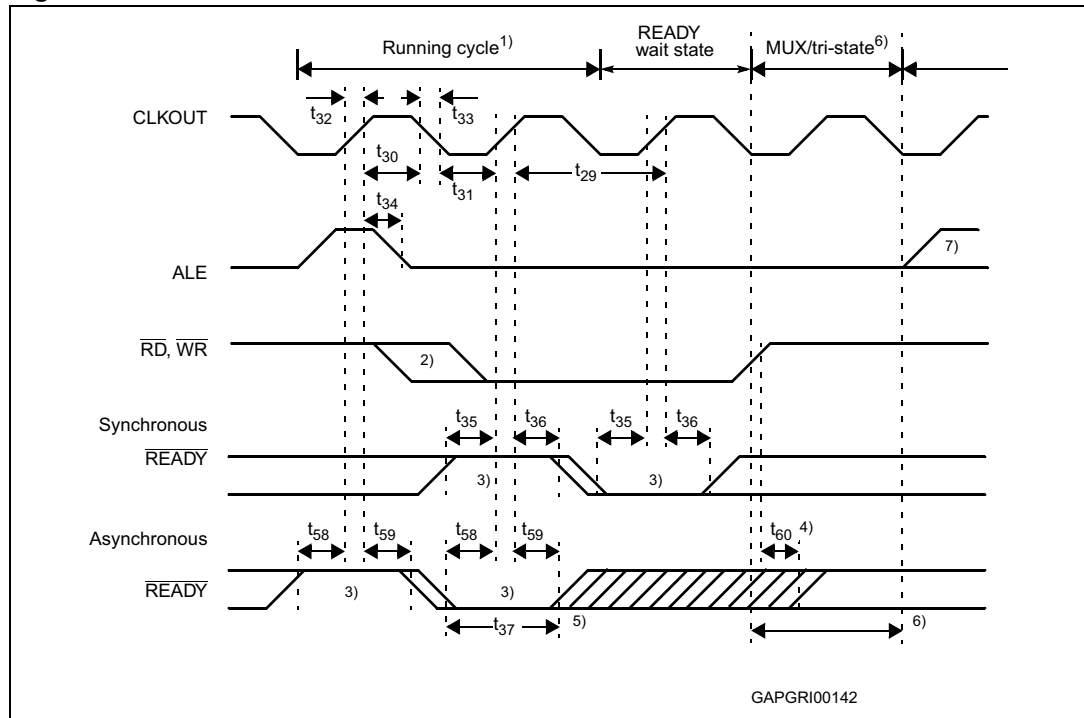

1. Cycle as programmed, including MCTC wait states (example shows 0 MCTC WS).
2. The leading edge of the respective command depends on RW-delay.
3.  $\overline{\text{READY}}$  sampled HIGH at this sampling point generates a  $\overline{\text{READY}}$  controlled wait state,  $\overline{\text{READY}}$  sampled LOW at this sampling point terminates the currently running bus cycle.
4.  $\overline{\text{READY}}$  may be deactivated in response to the trailing (rising) edge of the corresponding command ( $\overline{\text{RD}}$  or  $\overline{\text{WR}}$ ).
5. If the Asynchronous  $\overline{\text{READY}}$  signal does not fulfill the indicated setup and hold times with respect to CLKOUT (for example, because CLKOUT is not enabled), it must fulfill  $t_{37}$  in order to be safely synchronized. This is guaranteed, if  $\overline{\text{READY}}$  is removed in response to the command (see Note 4).
6. Multiplexed bus modes have a MUX wait state added after a bus cycle, and an additional MTTC wait state may be inserted here. For a multiplexed bus with MTTC wait state this delay is two CLKOUT cycles, for a demultiplexed bus without MTTC wait state this delay is zero.
7. The next external bus cycle may start here.

### 24.8.19 External bus arbitration

$V_{DD} = 5\text{ V} \pm 10\%$ ,  $V_{SS} = 0\text{ V}$ ,  $T_A = -40\text{ to }+125\text{ }^\circ\text{C}$ ,  $C_L = 50\text{ pF}$

**Table 73. External bus arbitration timings**

Symbol	Parameter	$f_{\text{CPU}} = 40\text{ MHz}$ $\text{TCL} = 12.5\text{ ns}$		Variable CPU clock $1/2\text{ TCL} = 1\text{ to }40\text{ MHz}$		Unit
		Min	Max	Min	Max	
$t_{61}$	SR $\overline{\text{HOLD}}$ input setup time to CLKOUT	18.5	–	18.5	–	ns
$t_{62}$	CC CLKOUT to $\overline{\text{HLDA}}$ high or $\overline{\text{BREQ}}$ low delay	–	12.5	–	12.5	ns
$t_{63}$	CC CLKOUT to $\overline{\text{HLDA}}$ low or $\overline{\text{BREQ}}$ high delay	–	12.5	–	12.5	ns
$t_{64}$	CC $\overline{\text{CSx}}$ release <sup>(1)</sup>	–	20	–	20	ns
$t_{65}$	CC $\overline{\text{CSx}}$ drive	-4	15	-4	15	ns
$t_{66}$	CC Other signals release <sup>(1)</sup>	–	20	–	20	ns
$t_{67}$	CC Other signals drive	-4	15	-4	15	ns

1. Partially tested, guaranteed by design characterization

**Figure 59. External bus arbitration (releasing the bus)**

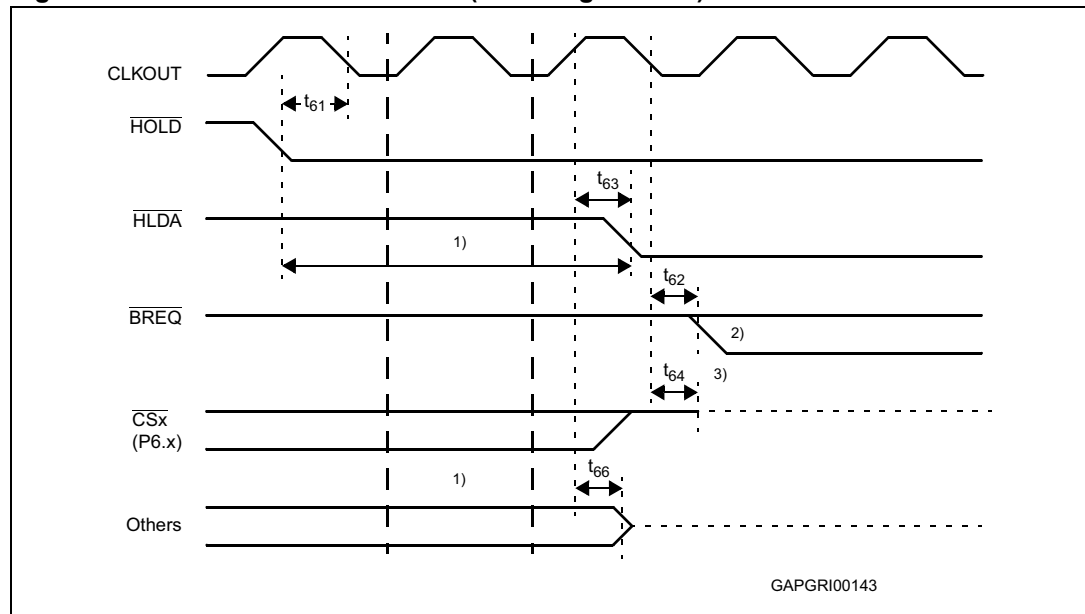

1. The ST10F272M will complete the currently running bus cycle before granting bus access.
2. This is the first possibility for  $\overline{\text{BREQ}}$  to become active.
3. The  $\overline{\text{CS}}$  outputs will be resistive high (pull-up) after  $t_{64}$ .

Figure 60. External bus arbitration (regaining the bus)

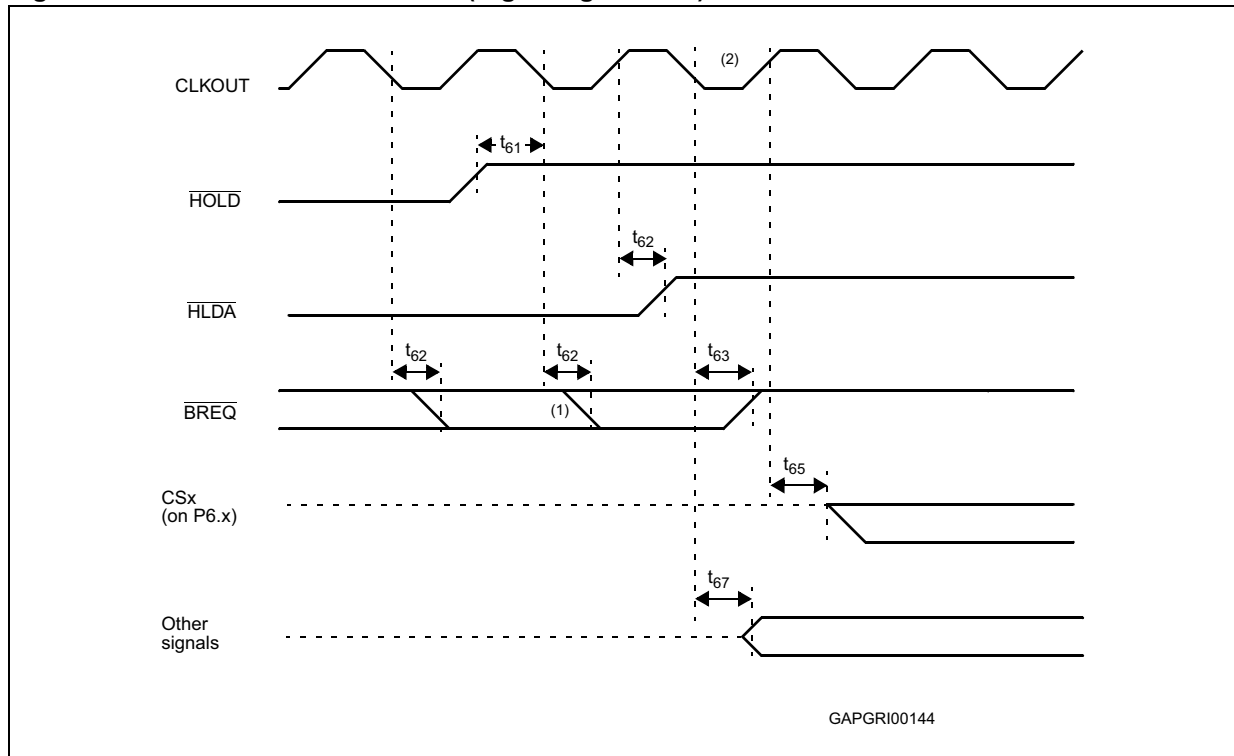

1. This is the last chance for  $\overline{\text{BREQ}}$  to trigger the indicated regain-sequence. Even if  $\overline{\text{BREQ}}$  is activated earlier, the regain-sequence is initiated by  $\text{HOLD}$  going high. Please note that  $\text{HOLD}$  may also be deactivated without the ST10F272M requesting the bus.
2. The next ST10F272M driven bus cycle may start here.

### 24.8.20 High-speed synchronous serial interface (SSC) timing

#### 24.8.20.1 Master mode

$V_{DD} = 5\text{ V} \pm 10\%$ ,  $V_{SS} = 0\text{ V}$ ,  $T_A = -40\text{ to }+125\text{ }^\circ\text{C}$ ,  $C_L = 50\text{ pF}$

Table 74. SSC master mode timings

Symbol	Parameter	Maximum baudrate 6.6 Mbaud <sup>(1)</sup> @ $f_{CPU} = 40\text{ MHz}$ ( $\langle \text{SSCBR} \rangle = 0002\text{h}$ )		Variable baudrate ( $\langle \text{SSCBR} \rangle = 0001\text{h} - \text{FFFFh}$ )		Unit
		Min	Max	Min	Max	
t <sub>300</sub>	CC SSC clock cycle time <sup>(2)</sup>	150	150	8TCL	262144 TCL	ns
t <sub>301</sub>	CC SSC clock high time	63	–	t <sub>300</sub> /2 - 12	–	ns
t <sub>302</sub>	CC SSC clock low time	63	–	t <sub>300</sub> /2 - 12	–	ns
t <sub>303</sub>	CC SSC clock rise time	–	10	–	10	ns
t <sub>304</sub>	CC SSC clock fall time	–	10	–	10	ns
t <sub>305</sub>	CC Write data valid after shift edge	–	15	–	15	ns
t <sub>306</sub>	CC Write data hold after shift edge <sup>(3)</sup>	-2	–	-2	–	ns

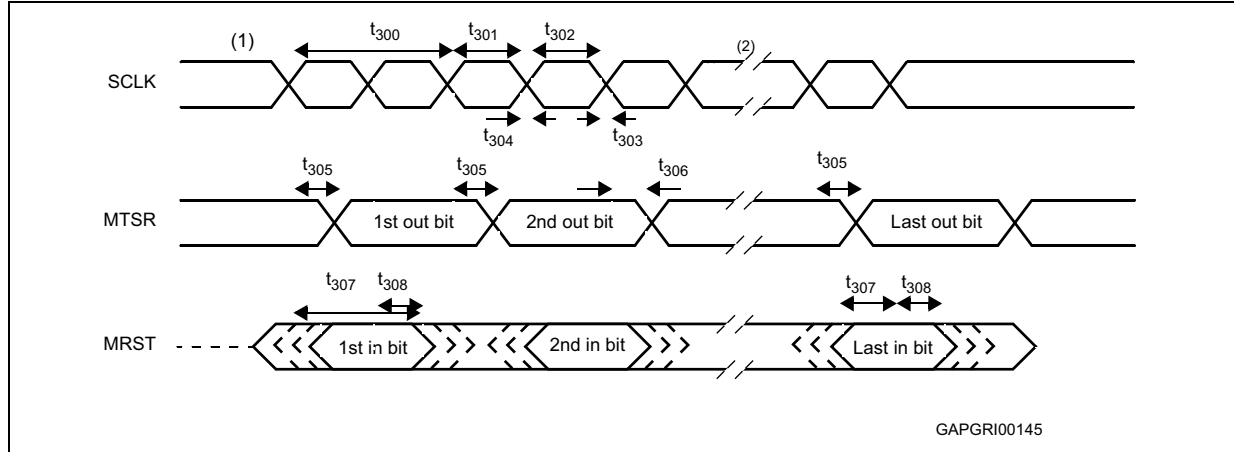

Table 74. SSC master mode timings (continued)

Symbol	Parameter	Maximum baudrate 6.6 Mbaud <sup>(1)</sup> @ f <sub>CPU</sub> = 40 MHz (<SSCBR> = 0002h)		Variable baudrate (<SSCBR> = 0001h - FFFFh)		Unit
		Min	Max	Min	Max	
t <sub>307p</sub> SR	Read data setup time before latch edge, phase error detection on (SSCPEN = 1)	37.5	–	2TCL + 12.5	–	ns
t <sub>308p</sub> SR	Read data hold time after latch edge, phase error detection on (SSCPEN = 1)	50	–	4TCL	–	ns
t <sub>307</sub> SR	Read data setup time before latch edge, phase error detection off (SSCPEN = 0)	25	–	2TCL	–	ns
t <sub>308</sub> SR	Read data hold time after latch edge, phase error detection off (SSCPEN = 0)	0	–	0	–	ns

1. When 40 MHz CPU clock is used the maximum baudrate cannot be higher than 6.6Mbaud (<SSCBR> = '2h') due to the limited granularity of <SSCBR>. Value '1h' for <SSCBR> can be used only with CPU clock equal to (or lower than) 32 MHz.
2. Formula for SSC clock cycle time: t<sub>300</sub> = 4 TCL x (<SSCBR> + 1) Where <SSCBR> represents the content of the SSC baudrate register, taken as unsigned 16-bit integer. Minimum limit allowed for t<sub>300</sub> is 125 ns (corresponding to 8 Mbaud).
3. Partially tested, guaranteed by design characterization.

Figure 61. SSC master timing



1. The phase and polarity of shift and latch edge of SCLK is programmable. This figure uses the leading clock edge as shift edge (drawn in bold), with latch on trailing edge (SSCPH = 0b), Idle clock line is low, leading clock edge is low-to-high transition (SSCPO = 0b).
2. The bit timing is repeated for all bits to be transmitted or received.

## 24.8.20.2 Slave mode

$V_{DD} = 5\text{ V} \pm 10\%$ ,  $V_{SS} = 0\text{ V}$ ,  $T_A = -40\text{ to }+125\text{ }^\circ\text{C}$ ,  $C_L = 50\text{ pF}$

Table 75. SSC slave mode timings

Symbol	Parameter	Maximum baudrate 6.6 Mbaud <sup>(1)</sup> @ $f_{CPU} = 40\text{ MHz}$ ( $\langle SSCBR \rangle = 0002h$ )		Variable baudrate ( $\langle SSCBR \rangle = 0001h - FFFFh$ )		Unit
		Min	Max	Min	Max	
$t_{310}$ SR	SSC clock cycle time <sup>(2)</sup>	150	150	8TCL	262144 TCL	ns
$t_{311}$ SR	SSC clock high time	63	–	$t_{310}/2 - 12$	–	ns
$t_{312}$ SR	SSC clock low time	63	–	$t_{310}/2 - 12$	–	ns
$t_{313}$ SR	SSC clock rise time	–	10	–	10	ns
$t_{314}$ SR	SSC clock fall time	–	10	–	10	ns
$t_{315}$ CC	Write data valid after shift edge	–	55	–	2TCL + 30	ns
$t_{316}$ CC	Write data hold after shift edge	0	–	0	–	ns
$t_{317p}$ SR	Read data setup time before latch edge, phase error detection on (SSCPEN = 1)	62	–	4TCL + 12	–	ns
$t_{318p}$ SR	Read data hold time after latch edge, phase error detection on (SSCPEN = 1)	87	–	6TCL + 12	–	ns
$t_{317}$ SR	Read data setup time before latch edge, phase error detection off (SSCPEN = 0)	6	–	6	–	ns
$t_{318}$ SR	Read data hold time after latch edge, phase error detection off (SSCPEN = 0)	31	–	2TCL + 6	–	ns

- When 40 MHz CPU clock is used the maximum baudrate cannot be higher than 6.6Mbaud ( $\langle SSCBR \rangle = '2h'$ ) due to the limited granularity of  $\langle SSCBR \rangle$ . Value '1h' for  $\langle SSCBR \rangle$  may be used only with CPU clock lower than 32 MHz (after checking that resulting timings are suitable for the master).
- Formula for SSC clock cycle time:  $t_{310} = 4\text{ TCL} * (\langle SSCBR \rangle + 1)$   
Where  $\langle SSCBR \rangle$  represents the content of the SSC baudrate register, taken as unsigned 16-bit integer.  
Minimum limit allowed for  $t_{310}$  is 125ns (corresponding to 8 Mbaud).

Figure 62. SSC slave timing

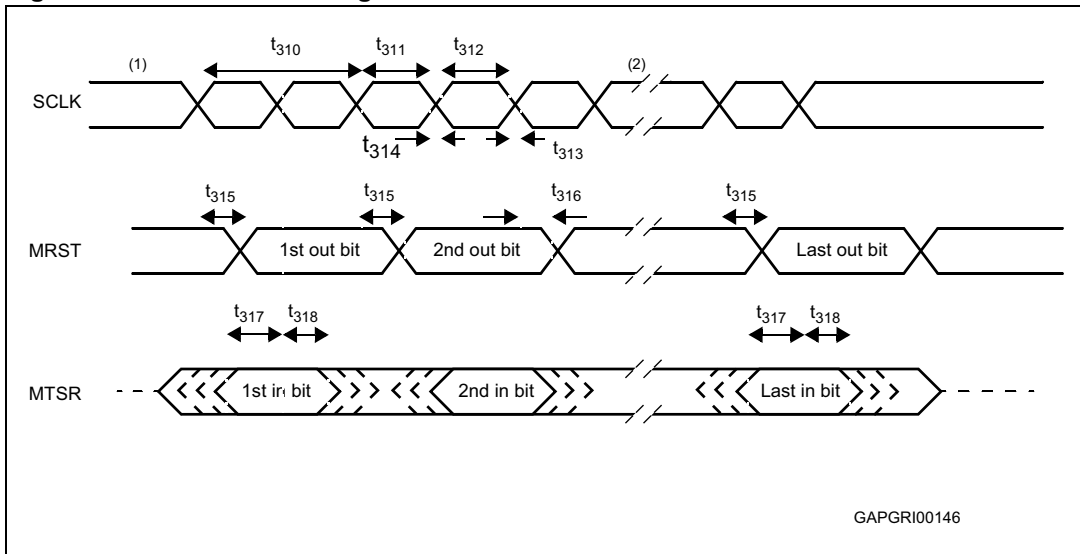

1. The phase and polarity of shift and latch edge of SCLK is programmable. This figure uses the leading clock edge as shift edge (drawn in bold), with latch on trailing edge (SSCPH = 0b), Idle clock line is low, leading clock edge is low-to-high transition (SSCPO = 0b).
2. The bit timing is repeated for all bits to be transmitted or received.

## 25 Package information

### 25.1 ECOPACK® packages

In order to meet environmental requirements, ST offers these devices in different grades of ECOPACK® packages, depending on their level of environmental compliance. ECOPACK® specifications, grade definitions and product status are available at: [www.st.com](http://www.st.com).

ECOPACK® is an ST trademark.

### 25.2 LQFP144 mechanical data

Figure 63. LQFP144 package dimension

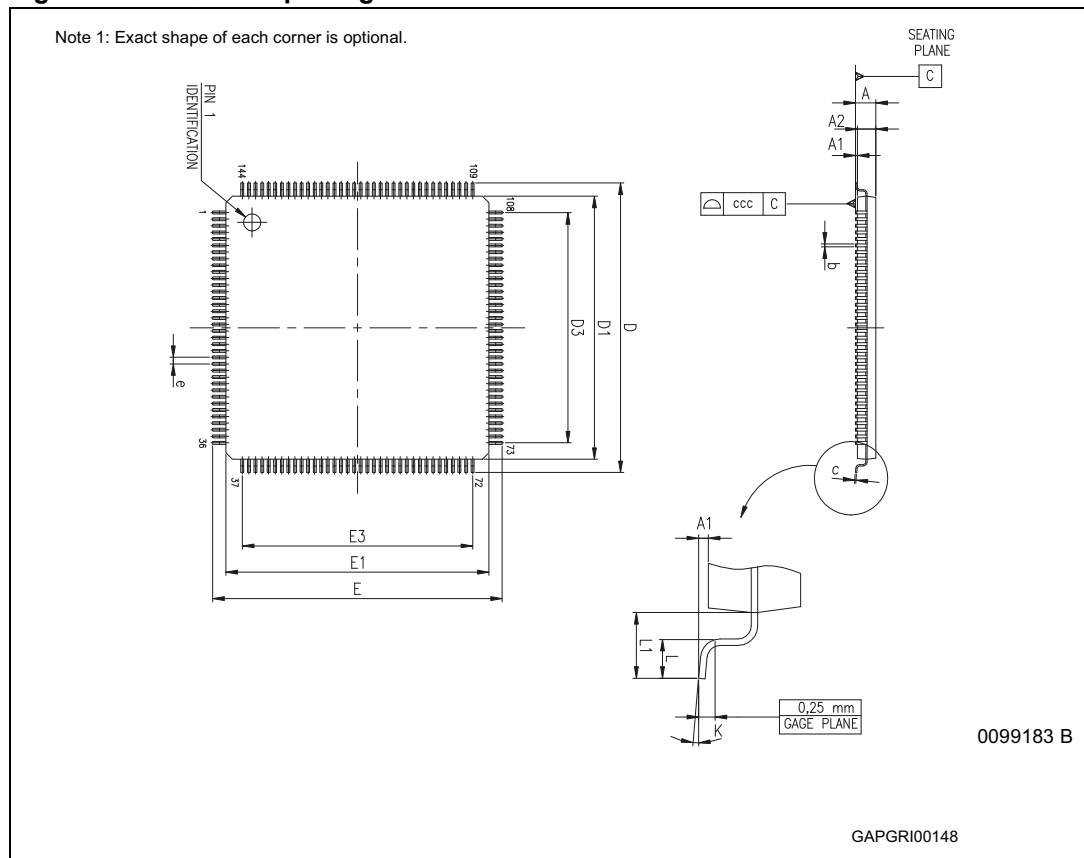

Table 76. LQFP144 mechanical data

Dim	mm			inches		
	Min	Typ	Max	Min	Typ	Max
A			1.600			0.0630
A1	0.050		0.150	0.0019		0.0059
A2	1.350	1.400	1.450	0.0531	0.0551	0.0571

Table 76. LQFP144 mechanical data (continued)

Dim	mm			inches		
	Min	Typ	Max	Min	Typ	Max
B	0.170	0.220	0.270	0.0067	0.0087	0.0106
C	0.090		0.200	0.0035		0.0089
D		22.000			0.8661	
D1		20.000			0.7874	
D3		17.500			0.6890	
e		0.500			0.0197	
E		22.000			0.8661	
E1		20.000			0.7874	
E3		17.500			0.6890	
L	0.450	0.600	0.750	0.0177	0.0236	0.0295
L1		1.000			0.0394	
K	3.5° min, 7° max					

## 26 Ordering information

**Table 77. Device summary**

Order code	Package	Packing	Temperature range (°C)	CPU frequency range (MHz)
ST10F272MR-4T3	LQFP144	Tray	-40 to +125	1 to 40
ST10F272MR-4TX3		Tape and reel		

## 27 Revision history

**Table 78. Document revision history**

Date	Revision	Changes
09-May-2007	1	Initial release
04-Jan-2008	2	<p>Changed document status from Preliminary Data to Datasheet <a href="#">Section 4: Memory organization on page 21</a>: Changed size of B0TF from 8 to 4Kbytes</p> <p><a href="#">Table 2: Summary of IFlash address range on page 21</a>: Changed size of B0TF from 8 to 4Kbytes</p> <p><a href="#">Figure 5: Flash structure on page 25</a>: Changed Test-Flash size from 8 to 4Kbytes</p> <p><a href="#">Table 5: Flash modules sectorization (write operations or with ROMS1 = '1' or bootstrap mode) on page 26</a>: Changed B0TF address and size (8 to 4Kbytes)</p> <p><a href="#">Section 14: A/D converter on page 66</a>: Replaced '40.630 CPU clock cycles' with '40630 CPU clock cycles' in end of section</p> <p><a href="#">Table 52: Absolute maximum ratings on page 123</a>: Changed V<sub>AREF</sub> value from "-0.3 to V<sub>DD</sub>" to "-0.5 to V<sub>DD</sub> + 0.5"</p> <p><a href="#">Table 53: Recommended operating conditions on page 124</a>: Added missing V<sub>AREF</sub> values.</p> <p><a href="#">Table 56: DC characteristics on page 126</a>: Changed max value for I<sub>PD1</sub> from 200μA to 150μA</p> <p><a href="#">Table 61: On-chip clock generator selections on page 142</a>:</p> <ul style="list-style-type: none"> <li>- changed external clock input range for f<sub>XTAL</sub> x 8</li> <li>- changed external clock input range for f<sub>XTAL</sub> x 1</li> <li>- changed external clock input range for f<sub>XTAL</sub> x 10</li> <li>- changed configuration from f<sub>XTAL</sub> x 16 to Reserved</li> </ul> <p><a href="#">Table 62: Internal PLL divider mechanism on page 145</a>:</p> <ul style="list-style-type: none"> <li>- changed external clock input range for f<sub>XTAL</sub> x 3</li> <li>- changed external clock input range for f<sub>XTAL</sub> x 8</li> </ul> <p><a href="#">Table 76: PQFP144 mechanical data on page 173</a> and <a href="#">Table 76: LQFP144 mechanical data on page 172</a>: Package mechanical data for inches converted to 4 decimal places</p>
15-May-2012	3	Removed PQFP144 package . Update <a href="#">Table 77: Device summary</a> .
18-Sep-2013	4	Updated Disclaimer

**Please Read Carefully:**

Information in this document is provided solely in connection with ST products. STMicroelectronics NV and its subsidiaries ("ST") reserve the right to make changes, corrections, modifications or improvements, to this document, and the products and services described herein at any time, without notice.

All ST products are sold pursuant to ST's terms and conditions of sale.

Purchasers are solely responsible for the choice, selection and use of the ST products and services described herein, and ST assumes no liability whatsoever relating to the choice, selection or use of the ST products and services described herein.

No license, express or implied, by estoppel or otherwise, to any intellectual property rights is granted under this document. If any part of this document refers to any third party products or services it shall not be deemed a license grant by ST for the use of such third party products or services, or any intellectual property contained therein or considered as a warranty covering the use in any manner whatsoever of such third party products or services or any intellectual property contained therein.

**UNLESS OTHERWISE SET FORTH IN ST'S TERMS AND CONDITIONS OF SALE ST DISCLAIMS ANY EXPRESS OR IMPLIED WARRANTY WITH RESPECT TO THE USE AND/OR SALE OF ST PRODUCTS INCLUDING WITHOUT LIMITATION IMPLIED WARRANTIES OF MERCHANTABILITY, FITNESS FOR A PARTICULAR PURPOSE (AND THEIR EQUIVALENTS UNDER THE LAWS OF ANY JURISDICTION), OR INFRINGEMENT OF ANY PATENT, COPYRIGHT OR OTHER INTELLECTUAL PROPERTY RIGHT.**

**ST PRODUCTS ARE NOT DESIGNED OR AUTHORIZED FOR USE IN: (A) SAFETY CRITICAL APPLICATIONS SUCH AS LIFE SUPPORTING, ACTIVE IMPLANTED DEVICES OR SYSTEMS WITH PRODUCT FUNCTIONAL SAFETY REQUIREMENTS; (B) AERONAUTIC APPLICATIONS; (C) AUTOMOTIVE APPLICATIONS OR ENVIRONMENTS, AND/OR (D) AEROSPACE APPLICATIONS OR ENVIRONMENTS. WHERE ST PRODUCTS ARE NOT DESIGNED FOR SUCH USE, THE PURCHASER SHALL USE PRODUCTS AT PURCHASER'S SOLE RISK, EVEN IF ST HAS BEEN INFORMED IN WRITING OF SUCH USAGE, UNLESS A PRODUCT IS EXPRESSLY DESIGNATED BY ST AS BEING INTENDED FOR "AUTOMOTIVE, AUTOMOTIVE SAFETY OR MEDICAL" INDUSTRY DOMAINS ACCORDING TO ST PRODUCT DESIGN SPECIFICATIONS. PRODUCTS FORMALLY ESCC, QML OR JAN QUALIFIED ARE DEEMED SUITABLE FOR USE IN AEROSPACE BY THE CORRESPONDING GOVERNMENTAL AGENCY.**

Resale of ST products with provisions different from the statements and/or technical features set forth in this document shall immediately void any warranty granted by ST for the ST product or service described herein and shall not create or extend in any manner whatsoever, any liability of ST.

ST and the ST logo are trademarks or registered trademarks of ST in various countries.

Information in this document supersedes and replaces all information previously supplied.

The ST logo is a registered trademark of STMicroelectronics. All other names are the property of their respective owners.

© 2013 STMicroelectronics - All rights reserved

STMicroelectronics group of companies

Australia - Belgium - Brazil - Canada - China - Czech Republic - Finland - France - Germany - Hong Kong - India - Israel - Italy - Japan - Malaysia - Malta - Morocco - Philippines - Singapore - Spain - Sweden - Switzerland - United Kingdom - United States of America

[www.st.com](http://www.st.com)



Компания «Океан Электроники» предлагает заключение долгосрочных отношений при поставках импортных электронных компонентов на взаимовыгодных условиях!

Наши преимущества:

- Поставка оригинальных импортных электронных компонентов напрямую с производств Америки, Европы и Азии, а так же с крупнейших складов мира;
- Широкая линейка поставок активных и пассивных импортных электронных компонентов (более 30 млн. наименований);
- Поставка сложных, дефицитных, либо снятых с производства позиций;
- Оперативные сроки поставки под заказ (от 5 рабочих дней);
- Экспресс доставка в любую точку России;
- Помощь Конструкторского Отдела и консультации квалифицированных инженеров;
- Техническая поддержка проекта, помощь в подборе аналогов, поставка прототипов;
- Поставка электронных компонентов под контролем ВП;
- Система менеджмента качества сертифицирована по Международному стандарту ISO 9001;
- При необходимости вся продукция военного и аэрокосмического назначения проходит испытания и сертификацию в лаборатории (по согласованию с заказчиком);
- Поставка специализированных компонентов военного и аэрокосмического уровня качества (Xilinx, Altera, Analog Devices, Intersil, Interpoint, Microsemi, Actel, Aeroflex, Peregrine, VPT, Syfer, Eurofarad, Texas Instruments, MS Kennedy, Miteq, Cobham, E2V, MA-COM, Hittite, Mini-Circuits, General Dynamics и др.);

Компания «Океан Электроники» является официальным дистрибьютором и эксклюзивным представителем в России одного из крупнейших производителей разъемов военного и аэрокосмического назначения «JONHON», а так же официальным дистрибьютором и эксклюзивным представителем в России производителя высокотехнологичных и надежных решений для передачи СВЧ сигналов «FORSTAR».



## JONHON

«JONHON» (основан в 1970 г.)

Разъемы специального, военного и аэрокосмического назначения:

(Применяются в военной, авиационной, аэрокосмической, морской, железнодорожной, горно- и нефтедобывающей отраслях промышленности)

«FORSTAR» (основан в 1998 г.)

ВЧ соединители, коаксиальные кабели,  
кабельные сборки и микроволновые компоненты:

(Применяются в телекоммуникациях гражданского и специального назначения, в средствах связи, РЛС, а так же военной, авиационной и аэрокосмической отраслях промышленности).



Телефон: 8 (812) 309-75-97 (многоканальный)

Факс: 8 (812) 320-03-32

Электронная почта: [ocean@oceanchips.ru](mailto:ocean@oceanchips.ru)

Web: <http://oceanchips.ru/>

Адрес: 198099, г. Санкт-Петербург, ул. Калинина, д. 2, корп. 4, лит. А