

MAX13053A- MAX13054A

+5V, 2Mbps CAN Transceiver with $\pm 65V$ Fault Protection, $\pm 25V$ CMR, and $\pm 25KV$ ESD

General Description

The MAX13053A* and MAX13054A are +5V CAN (Control Area Network) transceivers with integrated protection for industrial applications. These devices have extended $\pm 65V$ fault protection for equipment where overvoltage protection is required. It also incorporates high $\pm 25kV$ ESD HBM and an input common mode range (CMR) of $\pm 25V$, exceeding the ISO11898 specification of $-2V$ to $+7V$. This makes these parts well suited for applications that are in electrically noisy environments, where the ground planes are shifting relative to each other. This family features a variety of options to address common CAN application requirements; logic-level supply input V_L for interfacing with 1.62V to 5.5V logic, low-current standby mode, silent-mode to disable the transmitter, and a slow slew rate to minimize EMI.

These devices operate at a high-speed CAN data rate, allowing up to 2Mbps on small networks. Maximum speed on large networks may be limited by the number of nodes in a network, type of cabling, stub length, and other factors. These transceivers include a dominant timeout to prevent bus lockup caused by controller error or by a fault on the TXD input. When TXD remains in the dominant state (low) for longer than T_{DOM} , the driver is switched to the recessive state, releasing the bus. The MAX13053A* features a S pin where it enables and disables the transmitter for applications where you need the transceiver to receive only. The MAX13054A features a STBY pin for 3 modes of operation; standby mode for low current consumption, normal high speed mode, or a slow slew rate mode when an external 26.1k Ω is connected between ground and STBY pin.

The MAX13053A* and MAX13054A are available in standard 8-pin SOIC package and operate over the $-40^{\circ}C$ to $+125^{\circ}C$ temperature range.

* Denotes future product.

Applications

- Programmable Logic Controller
- Industrial Automation
- Building Automation
- Instrumentation
- Smart Grid Equipment
- Drone
- Motor Control

Benefits and Features

- Integrated Protection Increases Robustness
 - $\pm 65V$ Fault Tolerant CANH and CANL
 - $\pm 25kV$ ESD HBM (Human Body Model)
 - $\pm 25V$ Extended Common Mode Input Range (CMR)
 - Transmitter Dominant Timeout Prevents Lockup
 - Short-Circuit Protection
 - Thermal Shutdown
- Family Provides Flexible Design Options
 - Slow Slew Rate to Minimize EMI
 - Silent Mode S Disables Transmitter
 - STBY Input for Low-Current Mode
 - 1.62V to 5.5V Logic-Supply (V_L) Range
- High-Speed Operation of Up to 2Mbps
- Operating Temperature Range of $-40^{\circ}C$ to $+125^{\circ}C$ in 8-pin SOIC Package

Ordering Information appears at end of datasheet.

**MAX13053A-
MAX13054A**

**+5V, 2Mbps CAN Transceiver with ±65V Fault
Protection, ±25V CMR, and ±25KV ESD**

Simplified Block Diagram

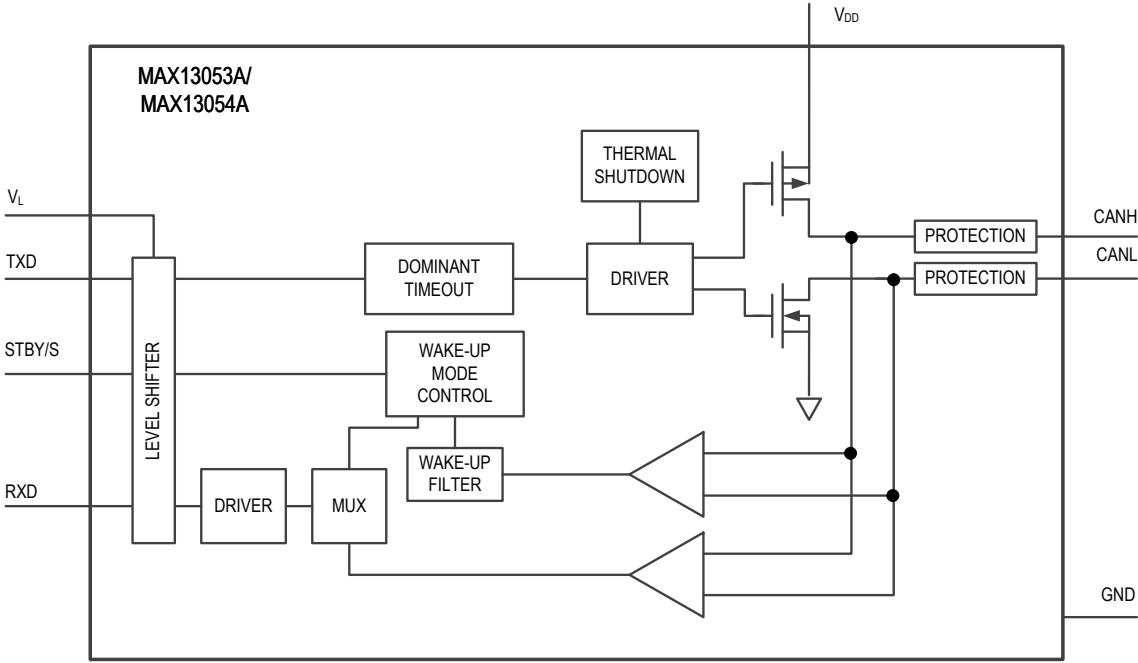

TABLE OF CONTENTS

General Description.....	1
Applications.....	1
Benefits and Features.....	1
Simplified Block Diagram.....	2
Absolute Maximum Ratings.....	6
Package Information.....	6
8 SOIC.....	6
Electrical Characteristics.....	6
Typical Operating Characteristics.....	12
Pin Configurations.....	15
MAX13053A.....	15
MAX13054A.....	15
Pin Description.....	15
Detailed Description.....	17
$\pm 65V$ Fault Protection.....	17
Transmitter.....	17
Transmitter Output Protection.....	17
Transmitter-Dominant Timeout.....	17
Receiver.....	17
Standby Mode (MAX13054A).....	18
Slow Slew Rate (MAX13054A).....	18
Silent Mode (MAX13053A).....	18
Logic Compatibility.....	18
Table 1. Transmitter and Receiver Truth Table (When Not Connected to the Bus).....	18
Applications Information.....	19
Reduced EMI and Reflections.....	19
Typical Application Circuits.....	19
Multidrop CAN Bus.....	19
Ordering Information.....	19

**MAX13053A-
MAX13054A**

**+5V, 2Mbps CAN Transceiver with $\pm 65V$ Fault
Protection, $\pm 25V$ CMR, and $\pm 25KV$ ESD**

LIST OF TABLES

Table 1. Typical Operating Curves.....	13
--	----

LIST OF FIGURES

<i>Figure 1. - Transmitter Test Circuit and Timing Diagram</i>	10
<i>Figure 2. TXD to RXD Loop Delay</i>	11
<i>Figure 3. RXD Timing Diagram</i>	11
<i>Figure 4. Transmitter-Dominant Timeout Timing Diagram</i>	12
<i>Figure 5. Standby Receiver Propagation Delay</i>	12

MAX13053A- MAX13054A

+5V, 2Mbps CAN Transceiver with ±65V Fault Protection, ±25V CMR, and ±25KV ESD

Absolute Maximum Ratings

VDD	-0.3V to +6V	+70°C.)	470.6mW
CANH or CANL (Continuous)	-65V to +65V	Multilayer Board (TA = +70°C, derate 7.6mW/°C above +70°C.)	606.1mW
TXD, STBY, S	-0.3V to +6V	Operating Temperature Range	-40°C to 125°C
RXD	-0.3V to (V _L + 0.3)V	Junction Temperature	+150°C
VL	-0.3V to (V _{DD} + 0.5V)	Storage Temperature Range	-60°C to +150°C
Short-Circuit Duration	Continuous	Soldering Temperature (reflow)	+260°C
Continuous Power Dissipation		Lead Temperature (soldering, 10sec)	+300°C
Single Layer Board (TA = +70°C, derate 5.9mW/°C above			

Stresses beyond those listed under "Absolute Maximum Ratings" may cause permanent damage to the device. These are stress ratings only, and functional operation of the device at these or any other conditions beyond those indicated in the operational sections of the specifications is not implied. Exposure to absolute maximum rating conditions for extended periods may affect device reliability.

Package Information

8 SOIC

Package Code	S8+4
Outline Number	21-0041
Land Pattern Number	90-0096
Thermal Resistance, Single-Layer Board:	
Junction to Ambient (θ _{JA})	170
Junction to Case (θ _{JC})	40
Thermal Resistance, Four-Layer Board:	
Junction to Ambient (θ _{JA})	132
Junction to Case (θ _{JC})	38

For the latest package outline information and land patterns (footprints), go to www.maximintegrated.com/packages. Note that a "+", "#", or "." in the package code indicates RoHS status only. Package drawings may show a different suffix character, but the drawing pertains to the package regardless of RoHS status.

Package thermal resistances were obtained using the method described in JEDEC specification JESD51-7, using a four-layer board. For detailed information on package thermal considerations, refer to www.maximintegrated.com/thermal-tutorial.

Electrical Characteristics

(V_{DD} = 4.5V to 5.5V, V_L = 1.62V to V_{DD}, R_L = 60Ω, C_L = 15pF, T_A = T_{MIN} to T_{MAX}, unless otherwise specified., Typical values are at V_{DD} = 5V, V_L = 3.3V, and T_A = +25°C, unless otherwise specified. (Note 1))

PARAMETER	SYMBOL	CONDITIONS	MIN	TYP	MAX	UNITS
Power						
Supply Voltage	V _{DD}	5V V _{DD} Range	4.5		5.5	V
Logic Supply Voltage	V _L		1.62		V _{DD}	V
Dominant Supply Current	I _{DD_DOM}	V _{DD} = 5V, TXD = 0V	No load	5	8	mA
			R _L = 60 Ω	50	70	

MAX13053A- MAX13054A

+5V, 2Mbps CAN Transceiver with ±65V Fault Protection, ±25V CMR, and ±25KV ESD

Electrical Characteristics (continued)

($V_{DD} = 4.5V$ to $5.5V$, $V_L = 1.62V$ to V_{DD} , $R_L = 60\Omega$, $C_L = 15pF$, $T_A = T_{MIN}$ to T_{MAX} , unless otherwise specified., Typical values are at $V_{DD} = 5V$, $V_L = 3.3V$, and $T_A = +25C$, unless otherwise specified. (Note 1))

PARAMETER	SYMBOL	CONDITIONS		MIN	TYP	MAX	UNITS
Recessive Supply Current	I_{DD_REC}	$V_{DD} = 5V$, $TXD = V_L$	No load		4		mA
			CANH shorted to CANL		4		
Standby Supply Current	I_{STBY}	STBY = logic-high			45		μA
Logic Supply Current	I_L	RXD = open	$V_L = 5V$		60		μA
			$V_L = 3.3V$		40		
			$V_L = 1.8V$		22		
UVLO Threshold Rising	V_{UVLO_R}	V_{DD} rising				4.25	V
UVLO Threshold Falling	V_{UVLO_F}	V_{DD} falling		3.45			V
Fault Protection							
ESD Protection (CANH, CANL to GND)		Human Body Model (HBM)			±25		kV
		Air Gap ISO 10605, IEC 61000-4-2			±15		
		Contact ISO 10605, IEC 61000-4-2			±10		
ESD Protection (All Other Pins)		Human Body Model (HBM)			±4		kV
Fault Protection Range	V_{FP}	CANH or CANL to GND		-65		+65	V
Thermal Shutdown	T_{SHDN}				+160		$^{\circ}C$
Thermal Shutdown Hysteresis	T_{HYST}				+20		$^{\circ}C$
Logic Interface (RXD, TXD, STBY, S)							
Input High Voltage	V_{IH}			0.7 x V_L			V
Input Low Voltage	V_{IL}	$2.25V \leq V_L \leq 5.5V$				0.8	V
		$1.62V \leq V_L \leq 2.25V$				0.6	
TXD Input Pull-Up Resistance	R_{PU_TXD}			100		250	k Ω
STBY, S Input Pull-Up Resistance	R_{PU_S}			100		250	k Ω
Output High Voltage	V_{OH}	Sourcing 4mA		$V_L - 0.4$			V
Output Low Voltage	V_{OL}	Sinking 4mA				0.4	V
CAN Bus Driver							
Bus Output Voltage (Dominant)	V_{O_DOM}	$t < t_{DOM}$, $TXD = 0V$, $R_L = 60\Omega$	CANH	2.75		4.5	V
			CANL	0.5		2.25	
Bus Output Voltage (Recessive)	V_{O_REC}	$TXD = V_L$, No load	CANH	2		3	V
			CANL	2		3	

MAX13053A- MAX13054A

+5V, 2Mbps CAN Transceiver with ±65V Fault Protection, ±25V CMR, and ±25KV ESD

Electrical Characteristics (continued)

($V_{DD} = 4.5V$ to $5.5V$, $V_L = 1.62V$ to V_{DD} , $R_L = 60\Omega$, $C_L = 15pF$, $T_A = T_{MIN}$ to T_{MAX} , unless otherwise specified., Typical values are at $V_{DD} = 5V$, $V_L = 3.3V$, and $T_A = +25C$, unless otherwise specified. (Note 1))

PARAMETER	SYMBOL	CONDITIONS	MIN	TYP	MAX	UNITS	
Bus Output Differential Voltage (Dominant)	V_{OD_DOM}	TXD = 0V, $R_L = 60\Omega$	$R_{CM} = 156\Omega$, $-5V \leq V_{CM} \leq 10V$, Figure 1	1.5		3	V
			$R_{CM} = \text{open}$	1.5		3	
Output Voltage Standby	V_{O_STBY}	$V_{TXD} = \text{STBY} = V_L$, no load	70		160	mV	
Bus Output Differential Voltage (Recessive)	V_{OD_REC}	TXD = V_L	$R_L = 60\Omega$	-120		12	mV
			No load	-500		50	
Short-Circuit Current	I_{SC_CANH}	TXD = CANH = 0V		175	250	mA	
	I_{SC_CANL}	TXD = 0V, CANL = V_{DD}		175	250		
Receiver							
Common Mode Input Range	V_{CM}	CANH or CANL to GND, RXD output valid	-25		25	V	
Common Mode Input Range Standby Mode	V_{CM_S}	CANH or CANL to GND, RXD output valid	-12		12	V	
Input Differential Voltage (Dominant)	V_{ID_DOM}	$-25V \leq V_{CM} \leq +25V$, TXD = V_L			0.9	V	
Input Differential Voltage (Recessive)	V_{ID_REC}	$-25V \leq V_{CM} \leq +25V$, TXD = V_L	0.5			V	
Standby Input Differential Voltage (Dominant)	V_{ID_SDOM}	$-12V \leq V_{CM} \leq +12V$, TXD = V_L			1.15	V	
Standby Input Differential Voltage (Recessive)	V_{ID_SREC}	$-12V \leq V_{CM} \leq +12V$, TXD = V_L	0.45			V	
Input Differential Hysteresis	V_{ID_HYS}	$-25V \leq V_{CM} \leq 25V$		90		mV	
Input Resistance	R_{IN}	TXD = V_L	10		50	k Ω	
Differential Input Resistance	R_{IN_DIFF}	TXD = V_L	20		100	k Ω	
Input Capacitance	C_{IN}	TXD = V_L (Note 2)		62	110	pF	
Differential Input Capacitance	C_{IN_DIFF}	TXD = V_L (Note 2)		31	55	pF	
Input Leakage Current	I_{LKG}	$V_{DD} = V_L = 0V$ CANH = CANL = 5V		150	280	μA	
Switching							
Driver Rise Time	t_R	$R_L = 60\Omega$, $C_{LD} = 100pF$, R_{CM} is open, Figure 1		10		ns	
Driver Fall Time	t_F	$R_L = 60\Omega$, $C_{LD} = 100pF$, R_{CM} is open, Figure 1		14		ns	
Slow Slew Driver Rise Time	t_{SSR}	$R_L = 60\Omega$, $C_{LD} = 100pF$, R_{CM} is open, Figure 1		200		ns	

MAX13053A- MAX13054A

+5V, 2Mbps CAN Transceiver with ±65V Fault Protection, ±25V CMR, and ±25KV ESD

Electrical Characteristics (continued)

($V_{DD} = 4.5V$ to $5.5V$, $V_L = 1.62V$ to V_{DD} , $R_L = 60\Omega$, $C_L = 15pF$, $T_A = T_{MIN}$ to T_{MAX} , unless otherwise specified., Typical values are at $V_{DD} = 5V$, $V_L = 3.3V$, and $T_A = +25C$, unless otherwise specified. (Note 1))

PARAMETER	SYMBOL	CONDITIONS	MIN	TYP	MAX	UNITS
Slow Slew Driver Fall Time	t_{SSF}	$R_L = 60\Omega$, $C_{LD} = 100pF$, R_{CM} is open, Figure 1		100		ns
TXD to RXD Loop Delay	t_{LOOP}	$R_L = 60\Omega$, Dominant to Recessive and Recessive to Dominant, Figure 2		65	100	ns
TXD Propagation Delay (Recessive to Dominant)	t_{ONTXD}	$R_L = 60\Omega$, $C_{LD} = 100pF$, R_{CM} is open, Figure 1		30	50	ns
TXD Propagation Delay (Dominant to Recessive)	t_{OFFTXD}	$R_L = 60\Omega$, $C_{LD} = 100pF$, R_{CM} is open, Figure 1		25	50	ns
RXD Propagation Delay (Recessive to Dominant)	t_{ONRXD}	$C_L = 15pF$, Figure 3		25	70	ns
RXD Propagation Delay (Dominant to Recessive)	t_{OFFRXD}	$C_L = 15pF$, Figure 3		30	70	ns
TXD-Dominant TimeOut	t_{DOM}	Figure 4	1.3		4.3	ms
Wake Up Time	t_{WAKE}			2.2		μs
Standby Propagation Delay	t_{PLH_STBY}	$C_L = 15pF$, Figure 5		300		ns
Standby to Normal Mode Delay	t_{D_SN}	$C_L = 15pF$, Figure 5		20		μs
Normal to Standby Dominant Delay	t_{D_NS}	$C_L = 15pF$, Figure 5		40		μs

Note 1: All units are 100% production tested at $T_A = +25^\circ C$. Specifications over temperature are guaranteed by design.

Note 2: Not production tested. Guaranteed at $T_A = 25^\circ C$.

**MAX13053A-
MAX13054A**

**+5V, 2Mbps CAN Transceiver with $\pm 65V$ Fault
Protection, $\pm 25V$ CMR, and $\pm 25KV$ ESD**

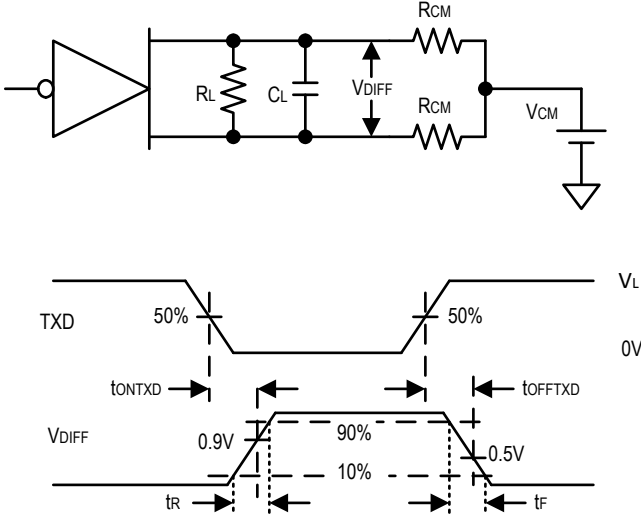
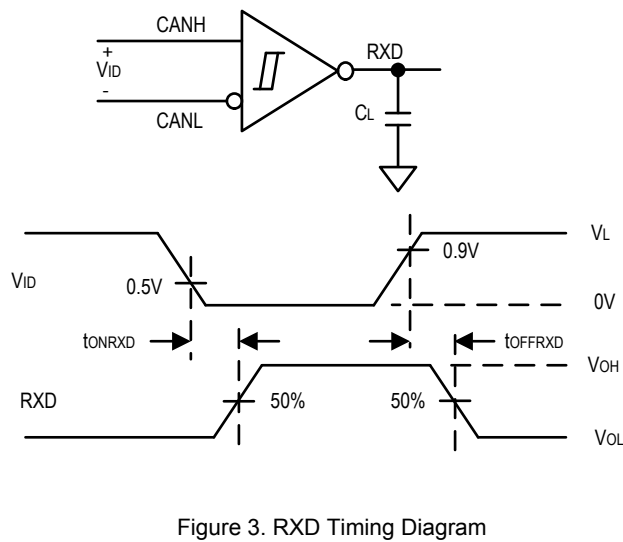
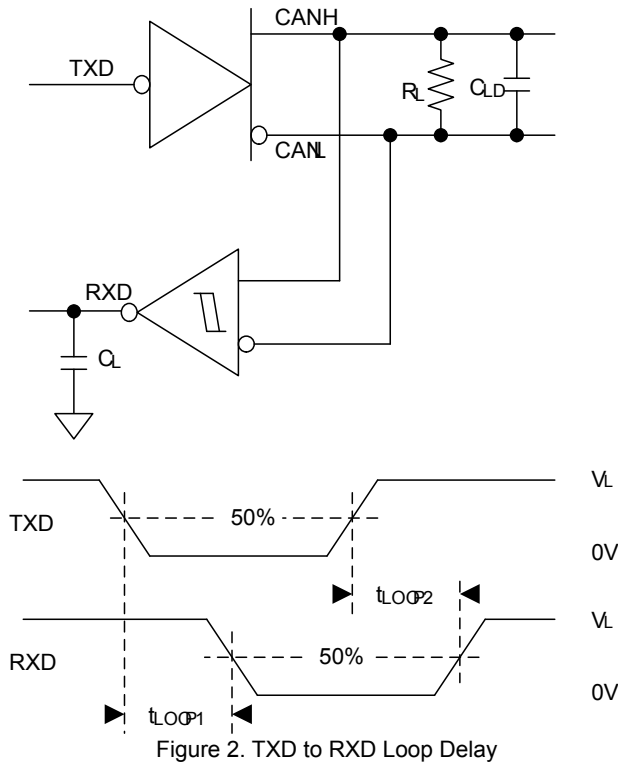

Figure 1. - Transmitter Test Circuit and Timing Diagram



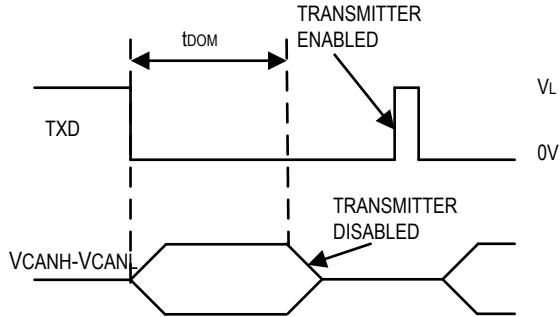

Figure 4. Transmitter-Dominant Timeout Timing Diagram

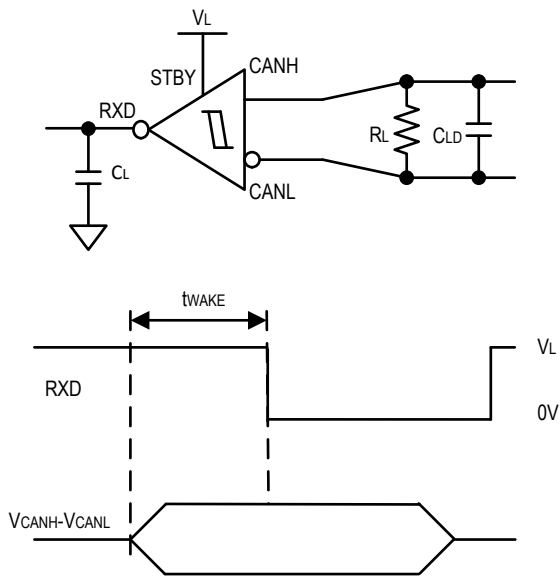

Figure 5. Standby Receiver Propagation Delay

Typical Operating Characteristics

$V_{DD} = 5V$, $V_L = 3.3V$, $R_L = 60\Omega$, $C_L = 15pF$, $T_A = +25^\circ C$, unless otherwise noted.

**MAX13053A-
MAX13054A**

+5V, 2Mbps CAN Transceiver with ±65V Fault Protection, ±25V CMR, and ±25KV ESD

Table 1. Typical Operating Curves

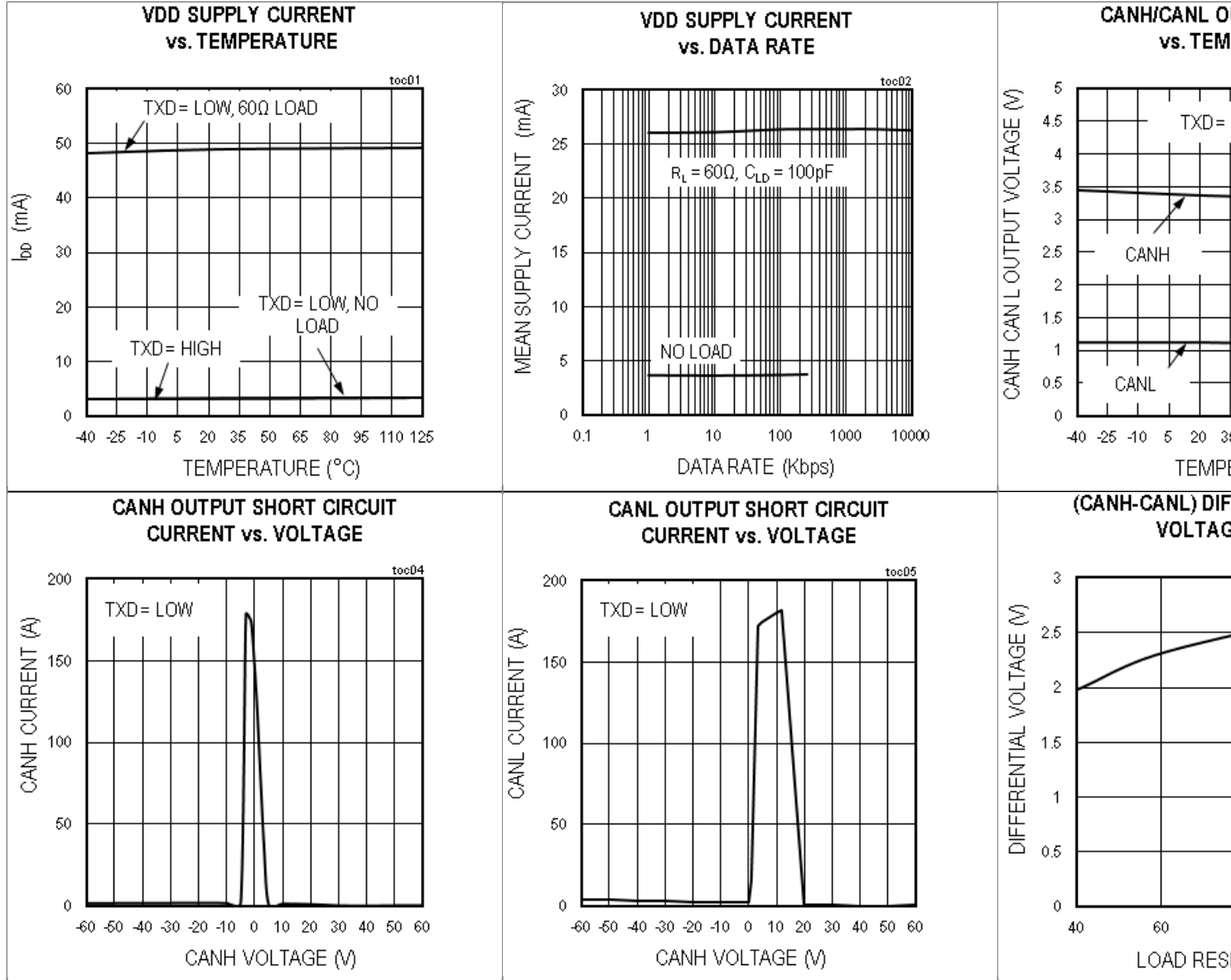

**MAX13053A-
MAX13054A**

+5V, 2Mbps CAN Transceiver with ±65V Fault Protection, ±25V CMR, and ±25KV ESD

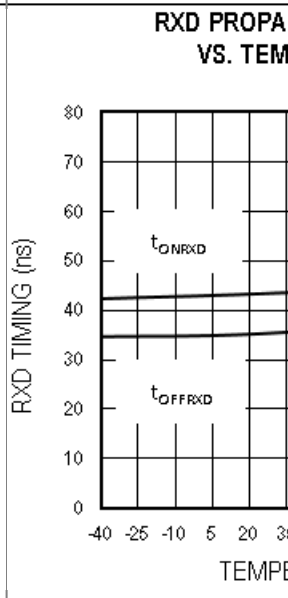
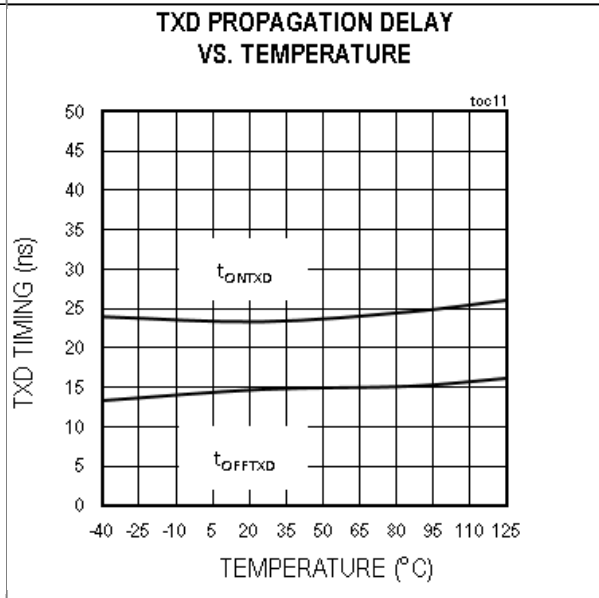
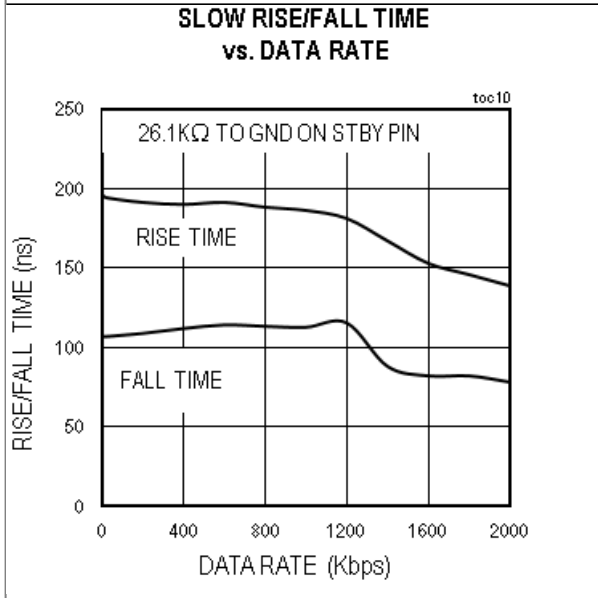
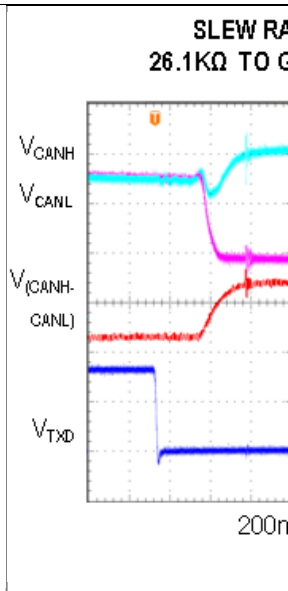
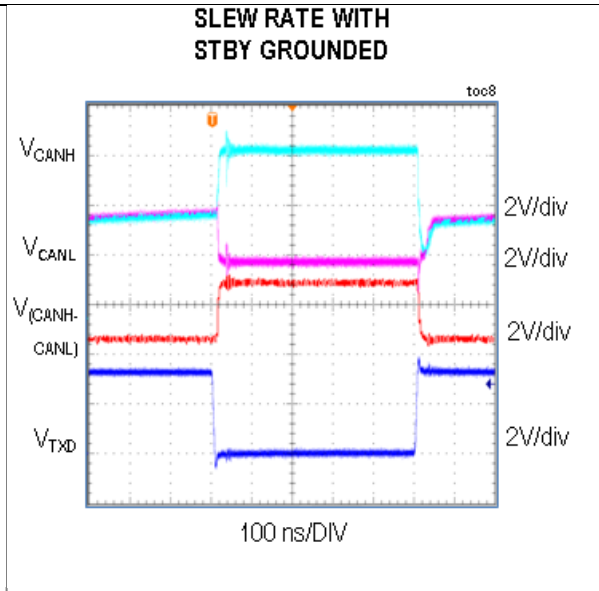
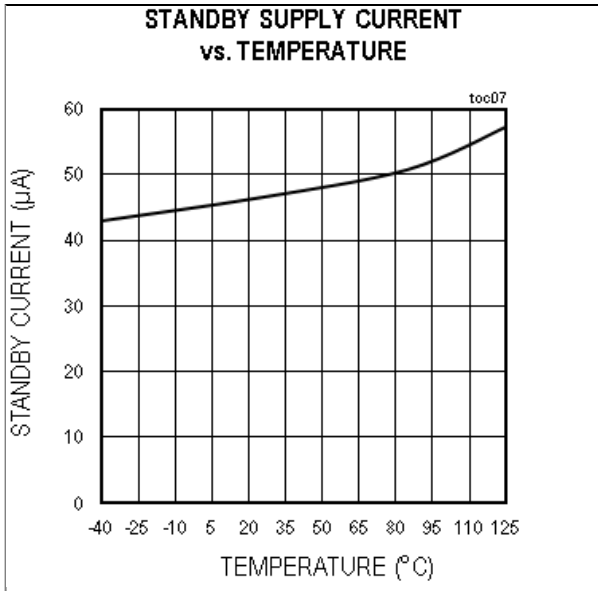

MAX13053A- MAX13054A

+5V, 2Mbps CAN Transceiver with ±65V Fault Protection, ±25V CMR, and ±25KV ESD

Pin Configurations

MAX13053A

TOP VIEW

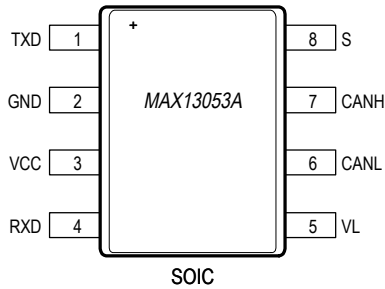

MAX13054A

TOP VIEW

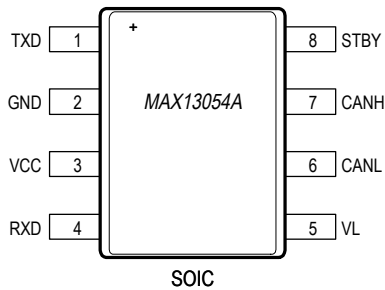

Pin Description

PIN		NAME	FUNCTION
MAX13053 A	MAX13054 A		
1	1	TXD	Transmit Data Input. Drive TXD high to set the driver in the recessive state. Drive TXD low to set the driver in the dominant state. TXD has an internal pullup to V_L .
2	2	GND	Ground
3	3	VDD	Supply Voltage. Bypass V_{DD} to GND with a 0.1 μ F capacitor.
4	4	RXD	Receive Data Output. RXD is high when CANH and CANL are in the recessive state. RXD is low when CANH and CANL are in the dominant state. RXD is referenced to V_L .

Pin Description (continued)

PIN		NAME	FUNCTION
MAX13053 A	MAX13054 A		
5	5	VL	Logic-Level Voltage Supply Input. Bypass V_L to GND with a 0.1 μ F capacitor as close to the device as possible.
6	6	CANL	CAN Bus-Line Low
7	7	CANH	CAN Bus-Line High
—	8	STBY	Standby Mode. A logic-high on STBY pin selects the standby mode. In standby mode, the transceiver is not able to transmit data and the receiver is in low power mode. A logic-low on STBY pin puts the transceiver in normal operating mode. A 26.1k Ω external resistor can be used to connect the STBY pin to ground for the slow slew rate.
8	—	S	Silent-Mode Input. Drive S low to enable TXD and to operate in high-speed mode. Drive S high to disable the transmitter. The receiver is active in normal operating mode.

Detailed Description

The MAX13053A and MAX13054A are a family of fault protected CAN transceivers designed for harsh industrial applications with a number of integrated robust protection feature set. These devices provide a link between the CAN protocol controller and the physical wires of the bus lines in a control area network (CAN). They can be used for DeviceNet applications as well.

The two CAN transceivers are fault protected up to ±65V, making it suitable for applications where overvoltage protection is required. These devices are rated up to a high ±25kV ESD of HBM (human body model), suitable for protection during the manufacturing process, and even in the field where there is human interface for installation and maintenance. In addition, a common mode voltage of ±25V enables communication in noisy environments where there are ground plane differences between different systems due to close proximity of heavy equipment machinery or operation from different transformers. The devices' dominant timeout prevents the bus from being blocked by a hung-up microcontroller, and the outputs CANH and CANL are short-circuit, current-limited, and are protected against excessive power dissipation by thermal shutdown circuitry that places the driver outputs in a high-impedance state.

Both devices can operate up to 2Mbps, while the MAX13054A has an option to slow the slew rate to 8V/μs to minimize EMI, enabling the use of unshielded-twisted or parallel cable. The MAX13054A features a standby mode where it shuts off the transmitter and reduces the current to 45μA typical. These CAN transceivers have a V_L pin where an integrated logic level translator enable it to interface with low voltage microcontrollers down to 1.8V ±10%.

±65V Fault Protection

These devices feature ±65V of fault protection. CANH and CANL data lines are capable of withstanding a short from -65V to +65V. This extended overvoltage range makes it suitable for applications where accidental shorts to power supply lines are possible due to human intervention.

Transmitter

The transmitter converts a single-ended input signal (TXD) from the local CAN controller to differential outputs for the bus lines CANH and CANL. The truth table for the transmitter and receiver is provided in Table 1.

Transmitter Output Protection

The MAX13053A and MAX13054A protect the transmitter output stage against a short-circuit to a positive or negative voltage by limiting the driver current. Thermal shutdown further protects the devices from excessive temperatures that may result from a short or high ambient temperature. The transmitter returns to normal operation once the temperature is lowered below the threshold.

Transmitter-Dominant Timeout

The devices feature a transmitter dominant timeout (t_{DOM}) that prevents erroneous CAN controllers from clamping the bus to a dominant level by maintaining a continuous low TXD signal. When TXD remains in the dominant state (low) for greater than 2.5ms typical t_{DOM} , the transmitter is disabled, releasing the bus to a recessive state (Figure 4). After a dominant timeout fault, the transmitter is re-enabled when receiving a rising edge at TXD. The transmitter dominant timeout limits the minimum possible data rate to 9kbps for standard CAN protocol.

Receiver

The receiver reads the differential input from the bus line CANH and CANL and transfers this data as a single-ended output RXD to the CAN controller. It consists of a comparator that senses the difference $V_{DIFF} = (CANH - CANL)$, with respect to an internal threshold of 0.7V. If $V_{DIFF} > 0.9V$, a logic-low is present on RXD. If $V_{DIFF} < 0.5V$, a logic-high is present. The CANH and CANL common-mode range is ±25V. RXD is a logic-high when CANH and CANL are shorted or terminated and undriven.

MAX13053A- MAX13054A

+5V, 2Mbps CAN Transceiver with $\pm 65V$ Fault Protection, $\pm 25V$ CMR, and $\pm 25KV$ ESD

Standby Mode (MAX13054A)

Drive STBY pin high for standby mode, which switches the transmitter off and the receiver to a low current and low-speed state. The supply current is reduced during standby mode. The bus line is monitored by a low differential comparator to detect and recognize a wakeup event on the bus line. Once the comparator detects a dominant bus level greater than $2.5\mu s$ typical t_{WAKE} , RXD pulls low. Drive the STBY low for normal operation.

Slow Slew Rate (MAX13054A)

Connect a $26.1k\Omega$ resistor between ground and the STBY pin. The STBY pin voltage should be between $0.1V$ to $0.6V$ to remain in slow slew rate. This will change the MAX13054A with a slow slew rate of $8V/\mu s$ for rising edge compared with normal mode at $180V/\mu s$. For falling edge, the slow slew rate is $20V/\mu s$ compared with normal mode at $140V/\mu s$.

Silent Mode (MAX13053A)

Drive S high to place the MAX13053A in silent mode. This disables the transmitter regardless of the voltage level at TXD. However, RXD is still active and monitors activity on the bus line.

Logic Compatibility

A separate input V_L allows the MAX13053A and MAX13054A to communicate with logic systems down to $1.62V$ while operating up to a $+5.5V$ supply. This provides a reduced input voltage threshold to the TXD, STBY, and S inputs, and provides a logic-high output at RXD compatible with the microcontroller's supply rail. The logic compatibility eliminates an external logic level translator and longer propagation delay due to level shifting. Connect V_L to V_{DD} to operate with $+5V$ logic systems.

Table 1. Transmitter and Receiver Truth Table (When Not Connected to the Bus)

STBY	TXD	TXD LOW TIME	CANH	CANL	BUS STATE	RXD
LOW	LOW	$< t_{DOM}$	HIGH	LOW	DOMINANT	LOW
LOW	LOW	$> t_{DOM}$	$V_{DD}/2$	$V_{DD}/2$	RECESSIVE	HIGH
LOW	HIGH	X	$V_{DD}/2$	$V_{DD}/2$	RECESSIVE	HIGH

X = Don't care

MAX13053A- MAX13054A

+5V, 2Mbps CAN Transceiver with ±65V Fault Protection, ±25V CMR, and ±25KV ESD

Applications Information

Reduced EMI and Reflections

In multidrop CAN applications, it is important to maintain a single linear bus of uniform impedance that is properly terminated at each end. A star, ring or tree configuration should never be used. Any deviation from the end-to-end wiring scheme creates a stub. High-speed data edges on a stub can create reflections back down to the bus. These reflections can cause data errors by eroding the noise margin of the system.

Although stubs are unavoidable in a multidrop system, care should be taken to keep these stubs as short as possible, especially when operating with high data rates.

Typical Application Circuits

Multidrop CAN Bus

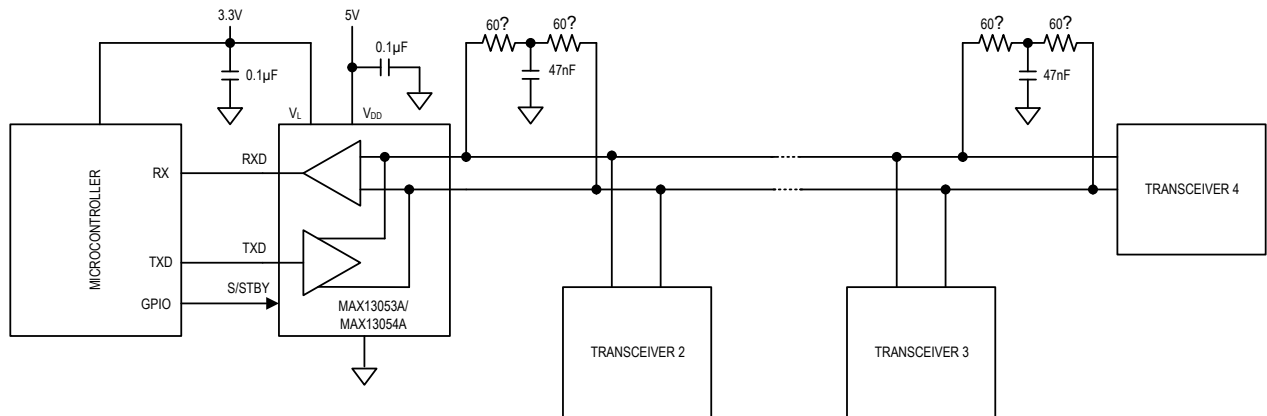

Ordering Information

Part Number	Pin 8	Temp Range	Pin-Package
MAX13053AEASA+*	S (Silent)	-40°C to +125°C	8 SO
MAX13054AEASA+	STBY (Standby)	-40°C to +125°C	8 SO

+ Denotes a lead(Pb)-free/RoHS-compliant package.

* Denotes future product.

Компания «Океан Электроники» предлагает заключение долгосрочных отношений при поставках импортных электронных компонентов на взаимовыгодных условиях!

Наши преимущества:

- Поставка оригинальных импортных электронных компонентов напрямую с производств Америки, Европы и Азии, а так же с крупнейших складов мира;
- Широкая линейка поставок активных и пассивных импортных электронных компонентов (более 30 млн. наименований);
- Поставка сложных, дефицитных, либо снятых с производства позиций;
- Оперативные сроки поставки под заказ (от 5 рабочих дней);
- Экспресс доставка в любую точку России;
- Помощь Конструкторского Отдела и консультации квалифицированных инженеров;
- Техническая поддержка проекта, помощь в подборе аналогов, поставка прототипов;
- Поставка электронных компонентов под контролем ВП;
- Система менеджмента качества сертифицирована по Международному стандарту ISO 9001;
- При необходимости вся продукция военного и аэрокосмического назначения проходит испытания и сертификацию в лаборатории (по согласованию с заказчиком);
- Поставка специализированных компонентов военного и аэрокосмического уровня качества (Xilinx, Altera, Analog Devices, Intersil, Interpoint, Microsemi, Actel, Aeroflex, Peregrine, VPT, Syfer, Eurofarad, Texas Instruments, MS Kennedy, Miteq, Cobham, E2V, MA-COM, Hittite, Mini-Circuits, General Dynamics и др.);

Компания «Океан Электроники» является официальным дистрибьютором и эксклюзивным представителем в России одного из крупнейших производителей разъемов военного и аэрокосмического назначения «JONHON», а так же официальным дистрибьютором и эксклюзивным представителем в России производителя высокотехнологичных и надежных решений для передачи СВЧ сигналов «FORSTAR».



JONHON

«JONHON» (основан в 1970 г.)

Разъемы специального, военного и аэрокосмического назначения:

(Применяются в военной, авиационной, аэрокосмической, морской, железнодорожной, горно- и нефтедобывающей отраслях промышленности)

«FORSTAR» (основан в 1998 г.)

ВЧ соединители, коаксиальные кабели,
кабельные сборки и микроволновые компоненты:

(Применяются в телекоммуникациях гражданского и специального назначения, в средствах связи, РЛС, а так же военной, авиационной и аэрокосмической отраслях промышленности).



Телефон: 8 (812) 309-75-97 (многоканальный)

Факс: 8 (812) 320-03-32

Электронная почта: ocean@oceanchips.ru

Web: <http://oceanchips.ru/>

Адрес: 198099, г. Санкт-Петербург, ул. Калинина, д. 2, корп. 4, лит. А