

Rugged Digital Networks Solutions

Reinforced Infocom Connectors for Harsh Environment

RJ Field - USB Field

Amphenol







Connecting to people + technology

www.rjfield.com



TABLE OF CONTENTS

Rugged Ethernet Solutions

Field installable

	RJFRB: Plastic circular shell - Reverse bayonet coupling	10
	RJF544: Plastic circular shell - Push pull coupling.....	13
	RJFEZ: Plastic rectangular shell - Lever coupling	15
	RJF: Metallic circular shell based on MIL-DTL-26482 H - Bayonet coupling	17
	RJF special receptacles: cable mount inline and PCB tails receptacles.....	20
	RJF receptacles and plug with 360° EMI backshells.....	21
	RJF for big insulation wire up to 1.6 mm [0.062 inch].....	22
	Self Closing Cap for RJ Field receptacles	23
	RJFTV: metallic circular shell based on MIL-DTL-38999 series III - Thread coupling with anti-decoupling device.....	24
	RJFTV with Self Closing Cap (SCC).....	27
	RJFTV: Receptacles and plugs with 360° EMI backshells.....	28
	RJFTV: Through bulkhead receptacles	30
	RJFTV: Stand off receptacles	31
	RJF-RJFTV: Environmentally & transversally sealed receptacles	34
	RJF/RJFTV: Hermetic receptacles.....	35
	RJFTV for big insulation wire up to 1.6 mm	36
	RJ45/M12 adaptor	37
	Special RJ45 adaptor for Military & Commercial Aeronautics	38
	High Reliability Cat5E Ethernet cable and cordsets.....	39

Cable assemblies

	RJ45/M12 Railway cable solution.....	42
	Jumper Railway intercoach	43

Rugged Electronics

Industrial Ethernet Switch for harsh environment

	RJSPC: Unmanaged or Ring Industrial Ethernet Switch - 5 Fast ports	46
--	--	----

Military Ethernet Switch for harsh environment with industrial EMI compliancy

	RJSML-8US1 & RJSML-8UG1: Unmanaged Military Ethernet Switch - Fast or Gigabit.....	50
	RJSML-MG7F3G: Managed Military Ethernet Switch - 7 Fast ports + 3 Gigabit ports.....	54

Military Ethernet Switch for harsh environment - Fully MIL-STD compliant







	RES-SCE-AC-8US: Unmanaged Miniature Portable Ethernet Switch - 8 Fast ports	58
	RESMLAC-8US: Unmanaged Military Ethernet Switch, MIL-DTL-38999 connectors - 8 Fast ports	60
	RJSMLAC-8MG: Managed Military Ethernet Switch, RJFTV connectors - 8 Gigabit ports.....	62
	RESMLAC-8MG: Managed Military Ethernet Switch, MIL-DTL-38999 connectors - 8 Gigabit ports	64
	RESMLAC-28MG: Managed Military Ethernet Switch - 24 Gigabit + 4 combo 10G ports.....	66

Military Ethernet Media Converter for harsh environment - Fully MIL-STD compliant

	RES-GMC: Unmanaged Military Ethernet Media Converter - 2 or 4 Gigabit ports	69
--	---	----

Rugged USB solutions (USB2.0)

Field installable

	USBF TV (USB-A): Metallic circular shell based on MIL-DTL-38999 series III - thread coupling with anti-decoupling device	72
	USBF TV Transversally Sealed receptacles.....	75
	USBF TV: hermetic receptacles.....	77
	USBFTV receptacles with 360° EMI backshells	78
	USBFTV Through bulkhead	79
	USBFTV Stand off receptacles	80
	USBF TV Self Closing Cap (SCC series).....	82
	Self Closing Cap (SCC) for USB receptacles	83
	USBF SC Quick release series	84
	USBBFTV (USB-B)	86
	USBBFTV Stand off receptacles.....	89
	USBBFTV Transversally sealed receptacles	91
	Self Closing Cap (SCC) for USBB receptacles.....	92
	Special USB adaptor for Military & Commercial Aeronautics	93
	High Reliability USB2.0 cordsets.....	94

Cable assemblies

	USB-A plastic & neoprene solutions with Self Closing Cap (SCC).....	96
	USB-B Field plastic - Overmolded cordset plug.....	99

Rugged Electronics

	Reinforced USBFTV memory keys.....	102
	Reinforced USB memory keys	103
	Reinforced USB amplifier.....	104



ATEX Solutions

	RJFTVX, USBFTVX, RJ11FTVX - RJ45, USB, RJ11/12 explosion proof solutions for Zone 2.....	106
	RJSPCEX Atex Zone 2 Rugged & IP68	112

Other Rugged solutions

Field installable

	FWFTV: metallic circular shell based on MIL-DTL-38999 series III - thread coupling with anti-decoupling device	114
	Self closing cap for IEEE1394 receptacles	117
	RJ11F: metallic circular shell based on MIL-DTL-26482 H - bayonet coupling	118
	Special RJ11 adaptor for Military & Commercial Aeronautics	120
	MTRJF TV: metallic circular shell based on MIL-DTL-38999 series III - thread coupling with anti-decoupling device	122
	LC Field: metallic circular shell based on MIL-DTL-38999 series III - thread coupling with anti-decoupling device.....	124

Glossary	126
----------------	-----

RUGGED ETHERNET SOLUTION SELECTION GUIDE

	Connectors	Series	Indust. Ethernet Spec.	Coupling Mechanism	Shape	Material	Specification	Prime Market	Page
F I E L D I N S T A L L A B L E		RJF RB		Reverse Bayonet	Circular	Plastic	N/A	Industrial & Telecom	10
		RJF544	IEC 60603-7 variant 12	Push Pull	Circular	Plastic	N/A	Industrial & Telecom	13
		RJF EZ	IEC 60603-7 variant 13	Lever	Rectangular	Plastic	N/A	Industrial & Telecom	15
		RJF	IEC 60603-7 variant 11	Bayonet	Circular	Metal	MIL-DTL-26482	Industrial Mil/Aero	17
		RJF Special	IEC 60603-7 variant 11	Bayonet	Circular	Metal	MIL-DTL-26482	Industrial Mil/Aero	20
		RJF Receptacles - Plugs with 360° EMI backshells		Bayonet	Circular	Metal	MIL-DTL-26482	Industrial Mil/Aero	21
		RJF For big insulation wire up to 1.6mm [0.062 inch]		Bayonet	Circular	Metal	MIL-DTL-26482	Industrial Mil/Aero	22
		RJFTV		Thread	Circular	Metal	MIL-DTL-38999 (Series III)	Mil/Aero & Rail Mass Transit	24
		RJF TV Receptacles - Plugs with 360° EMI backshells		Thread	Circular	Metal	MIL-DTL-38999 (Series III)	Mil/Aero & Rail Mass Transit	28
		RJF TV Special Through bulkhead		Thread	Circular	Metal	MIL-DTL-38999 (Series III)	Mil/Aero & Rail Mass Transit	30
		RJF TV Special PCB Stand-Off		Thread	Circular	Metal	MIL-DTL-38999 (Series III)	Mil/Aero & Rail Mass Transit	31
		RJF/RJFTV Environmentally Sealed, Transversally Sealed		Bayonet or Thread	Circular	Metal	MIL-DTL-26482 or MIL-DTL-38999 (Series III)	Mil/Aero & Industrial	34
		RJF/RJFTV Hermetic Receptacles		Bayonet or Thread	Circular	Metal	MIL-DTL-26482 or MIL-DTL-38999 (Series III)	Mil/Aero & Industrial	35
		RJF TV For big insulation wire up to 1.6 mm		Bayonet or Thread	Circular	Metal	MIL-DTL-26482 or MIL-DTL-38999 (Series III)	Mil/Aero	36
		RJ45/M12 Adaptors			Circular	Metal		Industrial & Rail Mass Transit	37
		Special RJ45 adaptor for Military & Commercial Aeronautics			Circular	Metal		Industrial & Rail Mass Transit	38
		High reliability Cat 5E cable and cordsets						Mil/Aero Industrial	39
	A S S E M B L E S		RJ45/M12 Railway Cable Solution		Bayonet	Circular	Metal	MIL-DTL-26482	Industrial & Rail Mass Transit
		Jumper		Thread	Circular	Metal	MIL-DTL-38999 (Series III)	Rail Mass Transit	43

Connectors	Series	Sealing	Type	Number of ports	Specification	Prime Market	Page
	RJSPC-5ES1/RJSPC-5RS1 Unmanaged Switch 5 Fast ports <i>For ATEX version, see page 112.</i>	IP67/68	Unmanaged	5		Mil/Aero & Industrial	46
	RJSML-8US1 / RJSML-8UG1 Unmanaged Military Ethernet Switch	IP67/68	Unmanaged	8		Mil/Aero	50
	RJSML-MG7F3G Managed Military Ethernet Switch 7 Fast ports + 3 Gigabit ports	IP67/68	Managed	10		Mil/Aero	54
	RES-SCE-AC-8US Unmanaged miniature portable Ethernet Switch 8 Fast ports	IP67/68	Unmanaged	8	MIL-STD	Mil/Aero	58
	RESMLAC-8US Unmanaged Military Ethernet Switch MIL-DTL-38999 connectors 8 Fast ports	IP67/68	Unmanaged	8	MIL-STD	Mil/Aero	60
	RJSMLAC-8MG Managed Military Ethernet Switch RJFTV connectors 8 Gigabit ports	IP67/68	Managed	8	MIL-STD	Mil/Aero	62
	RESMLAC-8MG Managed Military Ethernet Switch MIL-DTL-38999 connectors 8 Gigabit ports	IP67/68	Managed	8	MIL-STD	Mil/Aero	64
	RESMLAC-28MG Managed Military Ethernet Switch 24 Gigabit ports + 4 combo 10G ports	IP67/68	Managed	24 + 4 fiber (optional)	MIL-STD	Mil/Aero	66
	RES-GMC Unmanaged Military Ethernet Media Converter 2 or 4 Gigabit ports	IP67/68	Unmanaged	2 or 4	MIL-STD	Mil/Aero	69

R
U
G
G
E
D
E
L
E
C
T
R
O
N
I
C
S

NEW

NEW

NEW

NEW



NEW

NEW





RUGGED USB SOLUTION SELECTION GUIDE

	Connectors	Series	Coupling Mechanism	Shape	Material	Specification	Prime Market	Page
F I E L D I N S T A L L A B L E		USBFTV (USB-A)	Thread	Circular	Metal	MIL-DTL-38999 (Series III)	Mil/Aero, Rail Mass Transit & Industrial	72
		USBFTV Transversally Sealed Receptacles	Thread	Circular	Metal	MIL-DTL-38999 (Series III)	Mil/Aero, Rail Mass Transit & Industrial	75
		USBFTV Hermetic receptacles	Thread	Circular	Metal	MIL-DTL-38999 (Series III)	Mil/Aero & Industrial	77
		USBFTV special Receptacles with 360° EMI backshells	Thread	Circular	Metal	MIL-DTL-38999 (Series III)	Mil/Aero, Rail Mass Transit & Industrial	78
		Special USB version USB Through Bulkhead	Thread	Circular	Metal	MIL-DTL-38999 (Series III)	Mil/Aero & Industrial	79
		USBFTV Stand-Off receptacles	Thread	Circular	Metal	MIL-DTL-38999 (Series III)	Mil/Aero, Rail Mass transit & Industrial	80
		USBFTV SC Quick release series	Spring Release	Circular	Metal	N/A	Mil/Aero & Industrial	84
		USBFTV (USB-B)	Thread	Circular	Metal	MIL-DTL-38999 (Series III)	Mil/Aero, Rail Mass Transit & Industrial	86
		USBFTV Stand-off receptacles	Thread	Circular	Metal	MIL-DTL-38999 (Series III)	Mil/Aero, Rail Mass Transit & Industrial	89
		USBFTV Transversally Sealed Receptacles	Thread	Circular	Metal	MIL-DTL-38999 (Series III)	Mil/Aero, Rail Mass Transit & Industrial	91
		Special USB adaptor for Military & Commercial Aeronautics		Circular	Metal		Aeronautic	93
		High reliability USB 2.0 Cordsets					Mil/Aero, Rail Mass Transit & Industrial	94
	A S E C A B L E S		USB-A plastic with Self Closing Cap		Circular	Plastic	N/A	Industrial & Telecom
		USB B Field Plastic shell Overmolded cordset plug	Thread	Circular	Plastic	N/A	Industrial & Telecom	99
E L E C T R O N I C S		Reinforced USBFTV Memory Keys	Thread	Circular	Metal	MIL-DTL-38999 (Series III)	Mil/Aero & industrial	102
		Reinforced USB Memory Keys	Bayonet	Circular	Metal	N/A	Mil/Aero & Industrial	103
		Reinforced USB 2.0 amplifier	Thread	Circular	Metal	MIL-DTL-38999 (Series III)	Mil/Aero & Industrial	104

RUGGED ATEX ZONE 2 SOLUTION GUIDE

RUGGED ELECTRONICS		Connectors	Series	Coupling mechanism	Shape	Material	Specification	Prime Market	Page	
			RJFTVX, USBFTVX RJ11FTVX	IP68	Metal & Plastic				Factory Automation, Video, Oil & Gaz	106
RUGGED ELECTRONICS		Connectors	Series	Sealing	Material	Number of ports	Unmanaged	Ring	Prime Market	Page
			RJSPCEX	IP68	Plastic	5	X	X	Oil & Gas	112

OTHER RUGGED SOLUTIONS

FIELD INSTALLABLE		Connectors	Series	Coupling Mechanism	Shape	Material	Specification	Prime Market	Page
			FWFTV (FireWire)	Thread	Circular	Metal	MIL-DTL-38999 (Series III)	Mil/Aero & Video	114
	RJ11F (RJ11)	Bayonet	Circular	Metal	MIL-C-26482	MIL/Aero & Industrial	118		
	Special RJ11 adaptor for Military & Commercial Aeronautics		Circular	Metal		Aeronautic	120		
	MTRJFTV (MTRJ)	Thread	Circular	Metal	MIL-DTL-38999 (Series III)	Mil/Aero & Rail Mass Transit	122		
	LC Field	Thread	Circular	Metal	MIL-DTL-38999 (Series III)	Mil/Aero & Rail Mass Transit	124		

NOTES

21 horizontal dotted lines for note-taking.

Rugged Ethernet Solutions

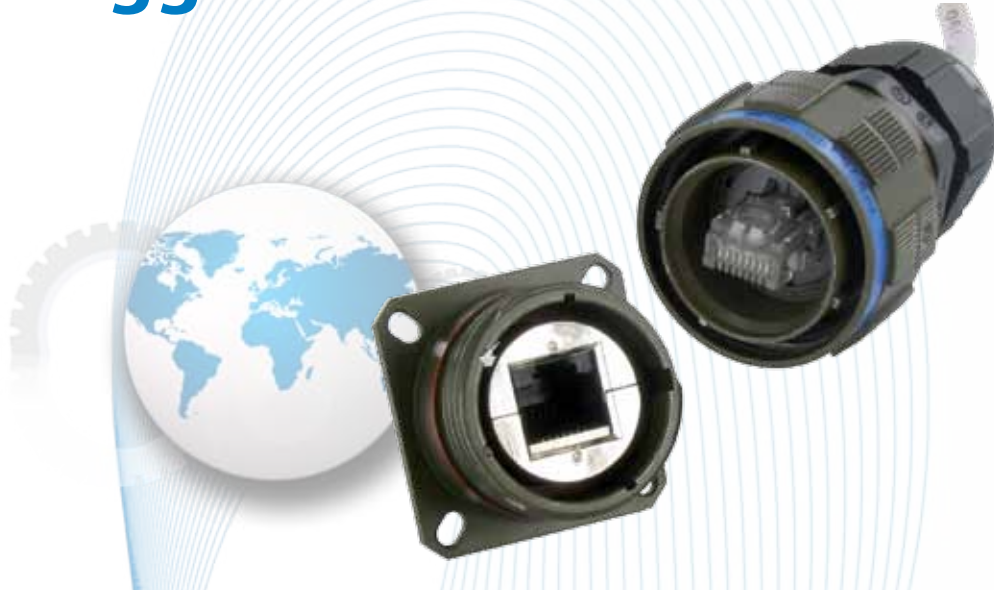

Field installable

Table of contents

	RJF RB: plastic circular shell - reverse bayonet coupling	10
	RJF544: plastic circular shell - push pull coupling	13
	RJF EZ: plastic rectangular shell - lever coupling	15
	RJF: metallic circular shell based on MIL-DTL-26482 H - bayonet coupling	17
	RJF special receptacles: cable mount inline & PCB tails receptacles	20
NEW	RJF - Receptacles & plugs with 360° EMI backshells	21
NEW	RJF for big insulation wire up to 1.6 mm [0.062 inch]	22
	Self Closing Cap (SCC) for RJ Field receptacles	23
	RJF TV: metallic circular shell based on MIL-DTL-38999 series III - thread coupling with anti-decoupling device	24
	RJF TV Self Closing Cap (SCC)	27
	RJF TV receptacles and plugs with 360° EMI backshells	28
	RJF TV Through bulkhead receptacles	30
	RJF TV Stand off receptacles	31
	RJF/RJF TV - Environmentally sealed, Transversally sealed receptacles	34
	RJF/RJF TV Hermetic receptacles	35
NEW	RJF TV for big insulation wire up to 1.6 mm	36
NEW	RJ45/M12 adaptators	37
NEW	Special RJ45 adaptators for Military & Commercial Aeronautics	38
	High reliability Cat 5E Ethernet cable & cordsets	39

RJF RB

Ethernet Connection System for Harsh Environment – Industrial Ethernet



IDC Receptacle
CAT 6



PCB Receptacle

RJFRB allows you to use an Ethernet Class D / Cat 5e and Class E / Cat 6 connection for 10 BaseT, 100 BaseTX or 1000 BaseT networks in harsh environments.

With the patented RJStop® system you can use a standard RJ45 cordset in a protective **composite** plug which will protect it from shocks, dust and fluids.

No hazardous on-field cabling and grounding!

Main characteristics

- Sealed against fluids and dust (IP68)
- Shock, Vibration and Traction resistant
- No cabling operation in field, no tools required
- **Reverse bayonet coupling**
- RJ45 cordset retention in the plug: 70 N in the axis
- Mating cycles: 500 min
- Compatible with cable diameter from 5,5 mm [0.216 in] to 7 mm [0.275 in]

Environmental protection

- Sealing: IP68
- Salt Spray > 1000 h
- Fire Retardant / Low Smoke: UL94 V0 and NFF 16102, DIN 5510-2
- Thermal Shock: 5 cycles at - 40°C / +100°C
- Operating Temperature: - 40°C / +85°C

Data transmission

10 BaseT, 100 BaseTX and 1000 BaseT networks
Cat 5e per TIA/EIA 568B and ClassD per ISO/IEC 11801
Cat6 per TIA/EIA 568B and ClassE per ISO/IEC 11801

Applications

- Telecom Equipments
- Video Control
- Robotics
- Industrial Process Control
- CNC Machines
- Special Machines
- Motion Control

Part Number Code

Series	RJF RB	7	1RA
RJF RB			
Shell Type			
6:	Composite reverse bayonet Plug, Plastic Gland		
7:	Composite jam nut Receptacle		
Back Terminations (For Receptacles only)			
1:	Female RJ45		
1RA:	Right angle female RJ45		
2:	RJ45 Cordset		
3U:	IDC cat6 - unshielded		
3F:	IDC cat6 - partial shielding		
3S:	IDC cat6 - 100% shielded		
5:	Straight PCB		
Cordset Length (For Receptacles with "2" back termination only)			
03 100BTX:	0.3m [11.81 inches]		
05 100BTX:	0.5m [19.68 inches]		
10 100BTX:	1m [39.37 inches]		
15 100BTX:	1.5m [59.05 inches]		

Remark: Cabling configuration: 100 BTX = 568B (Ethernet specification)

- Examples:**
- Plug: RJF RB 6
 - Receptacle, female RJ45 Back termination: RJF RB 71
 - Receptacle, right angle female RJ45 Back termination: RJF RB 71RA
 - Receptacle, 1,5m [59.05"] RJ45 cordset termination: RJF RB 72 15 100BTX

Plug

- Type 6 Shell with Plastic Gland

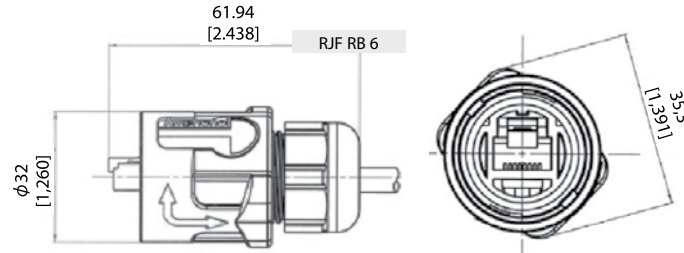

Receptacles

- Type 1: Female RJ45
(front mounting)

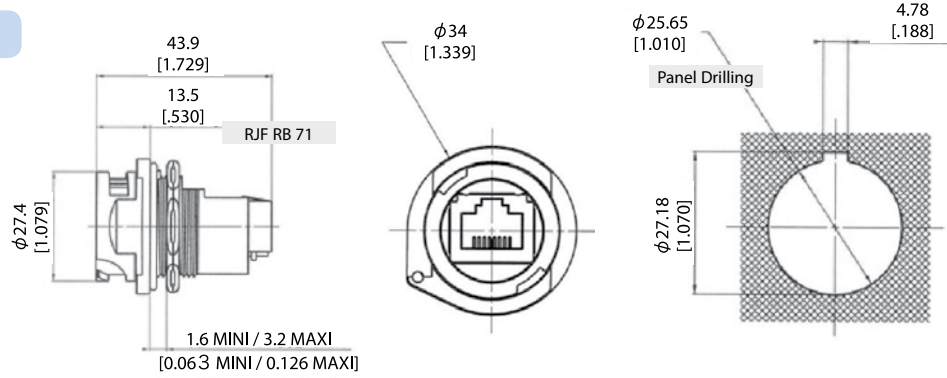

- Type 1RA: Right Angle Female RJ45
(front mounting)

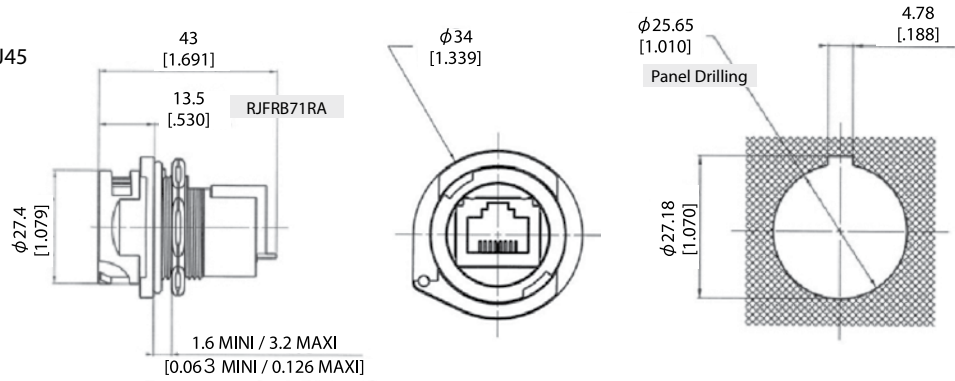

- Type 2: RJ45 Cordset
(front mounting)

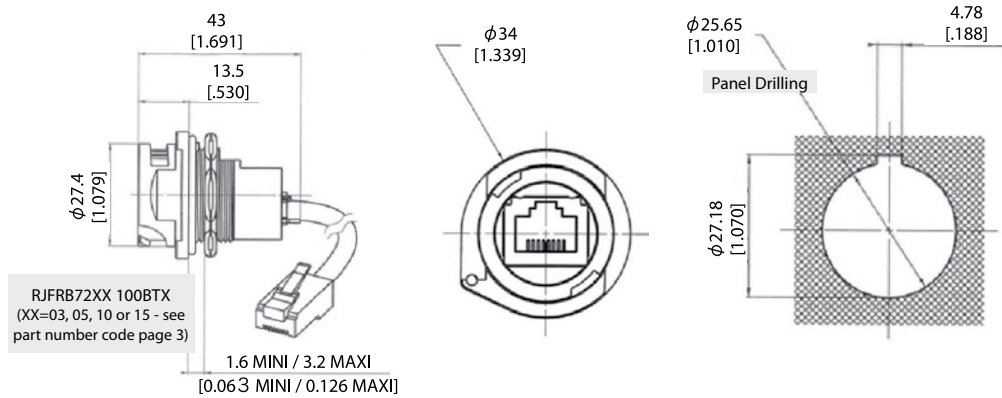

- Type 3: IDC CAT 6 termination
(rear mounting)



Unshielded: RJF RB 73U
Partial shielding RJF RB 73F

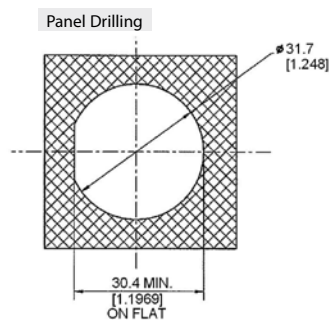

Shielded: RJFRB73S

■ Straight PCB termination receptacle:
(rear mounting)



Part number: RJF RB 75

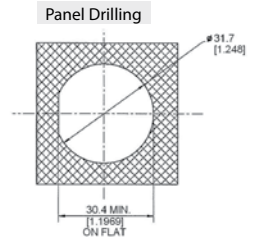
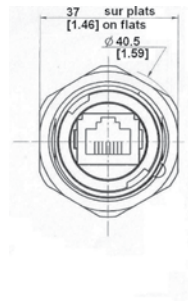

PCB Drilling RJFRB

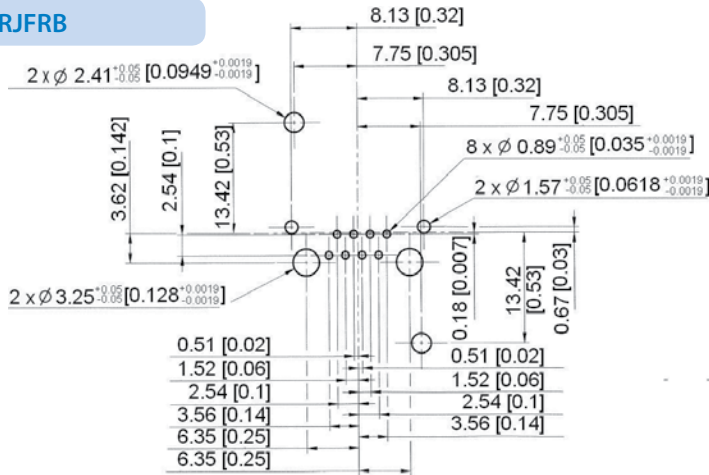

IMPORTANT NOTE
The customer's PCB design will determine the receptacle category.

Assembly Instructions



Accessories

■ IP68 Dust Caps



RJF RB C7
Cap for receptacles RJFRB71 / 71RA / 72xxx



RJF RB C75
Cap for receptacles RJFRB75 and RJFRB73x

RJF 544

Ethernet Connection System for Harsh Environment – Industrial Ethernet



RJF544 allows you to use an Ethernet Class D / Cat 5e connection for 10 BaseT, 100 Base TX or 1000 BaseT networks in harsh environments.
 With the patented RJStop® system you can use a standard RJ45 cordset in a protective **composite** plug which will protect it from shocks, dust and fluids.
No hazardous on-field cabling and grounding !

- Applications**
- Telecom Equipment
 - Video Control
 - Robotics
 - Industrial Process Control
 - CNC Machines
 - Special Machines
 - Motion Control
 - Tele-maintenance

- Main characteristics**
- Compliant with IEC 60603-7 variante 12
 - Shock, Vibration and Traction resistant
 - No cabling operation in field and no tools required
 - Sealed against fluids and dust (IP68)
 - **Quick Push Pull coupling**
 - RJ45 cordset retention in the plug: 100 N in the axis
 - Mating cycles: 500 min
 - Improved EMI Protection
 - Compatible with cable diameter from 6 mm [0.236 in] to 13 mm [0.512 in]



Now available with transversal sealing*
 *Seald in unmated condition

- Environmental Protection**
- Sealing: IP68
 - Salt Spray > 1000 h
 - Fire Retardant / Low Smoke: UL94 V0 and NFF 16102, DIN 5510-2
 - Vibrations: 10 – 500 Hz, 10 g, 3 axes: no discontinuity > 10 nano s.
 - Thermal Shock: 5 cycles at - 40°C / +100°C
 - Operating Temperature: - 40°C / +85°C

Data Transmission
 10 BaseT, 100 BaseTX and 1000 BaseT networks
 Cat 5e per TIA/EIA 568B and ClassD per ISO/IEC 11801

Part Number Code

Series	RJF 544	2	2	03 100BTX
RJField 544 - Push Pull				
Shell Type				
6:	Composite Push Pull Plug, Plastic Gland			
2:	Composite Square Flange Receptacle			
2S:	Composite Square Flange Receptacle Transversally sealed			
2M:	Metallized (Ni) Composite Square Flange Receptacle			
2SM:	Metallized (Ni) Composite Square Flange Receptacle Transversally sealed			
Back Terminations (For Receptacles only)				
1:	Female RJ45			
1RA:	Right Angle Female RJ45			
2:	RJ45 Cordset			
Cordset Length (For Receptacles with "2" Back Termination only)				
03 100BTX:	0.3 meters [11.81 inches]			
05 100BTX:	0.5 meters [19.68 inches]			
10 100BTX:	1 meter [39.37 inches]			
15 100BTX:	1.5 meters [59.05 inches]			
00:	8 tinned holes at the rear of the PCB to solder the cable			

Remark: Cabling configuration: 100 BTX = 568B (Ethernet specification)

- Examples:**
- Plug: RJF 544 6
 - Square flange receptacle, Female RJ45 Back termination: RJF 544 21
 - Metallized Square flange receptacle, Female RJ45 Back termination: RJF 544 2M 1
 - Square flange receptacle, 1,5m [59.05"] 100 BTX cordset termination: RJF 544 22 15 100BTX
 - Square flange receptacle, solder termination: RJF 544 22 00
 - Transversally sealed receptacle female RJ45 Back termination: RJF544 2S1

Plug

- Type 6 Shell with Plastic Gland

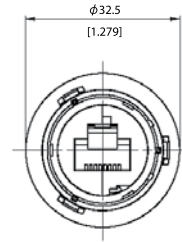
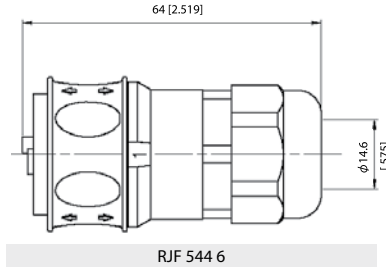

Receptacle

- Type 2S/2M/2SM Shell: Square flange receptacle with 4 mounting holes

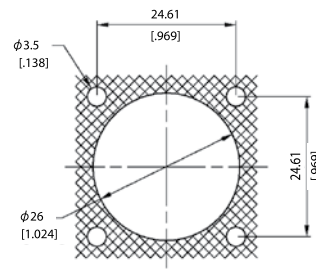
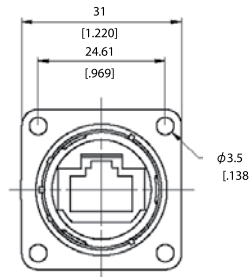
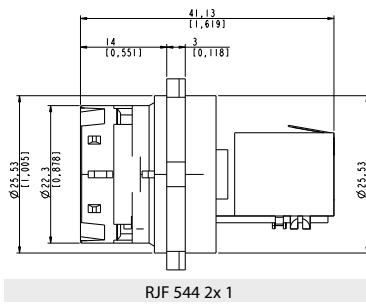
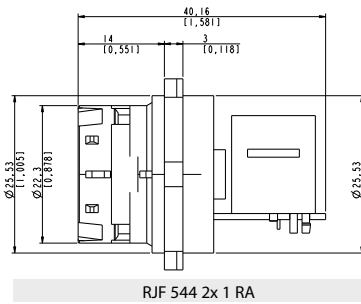

Panel Drilling
(same as #16 ML-C-5015)

Back terminations

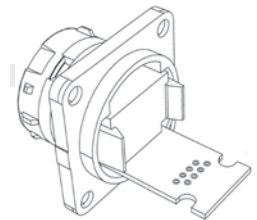
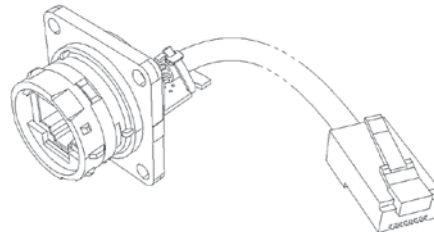
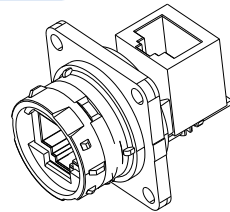
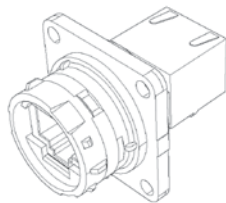

Type1: Female RJ45

Type1RA: Right Angle Female RJ45

Type2: RJ45 cordset

Type 2 - 00: Solder - 8 tinned holes

Notes: - Type 2 without RJ45 plug at the end of the cable is also available: consult factory

Accessories

- Rubber IP68 receptacle cap RJF 544BESC



- Panel gasket RJF 544 02JE



- IP68 Caps for Plug 544 02 BM

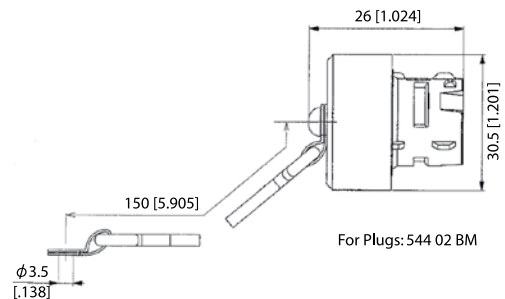

- Panel Gasket (Thickness: 0.6mm [0.039]): Part No. RJF 544 02 JE
- Plug Insert removal tool: Part No. 5440 OT 02

RJF EZ

Ethernet Connection System for Harsh Environment – Industrial Ethernet



RJFEZ allows you to use an Ethernet Class D / Cat. 5e connection for 10 BaseT, 100 BaseTX or 1000 BaseT networks in harsh environments. With the patented RJStop® system you can use a standard RJ45 cordset in a protective **composite** plug which will protect it from shocks, dust and fluids.

No hazardous on-field cabling and grounding!

Applications

- Telecom Equipment
- Video Control
- Robotics
- Industrial Process Control
- CNC Machines
- Special Machines
- Motion Control
- Tele-maintenance

Main characteristics

- Compliant with IEC 60603-7 variante 13
- Sealed against fluids and dust (IP68)
- Shock, Vibration and Traction resistant
- No cabling operation in field and no tools required
- **Quick lever coupling**
- RJ45 cordset retention in the plug: 70 N in the axis
- Mating cycles: 500 min
- Compatible with cable diameter from 5,5 mm [0.216 in] to 7 mm [0.275 in]

Environmental Protection

- Sealing: IP68
- Salt Spray > 1000 h
- Fire Retardant / Low Smoke: UL94 V0 and NFF 16102, DIN 5510-2
- Thermal Shock: 5 cycles at - 40°C / +100°C
- Operating Temperature: - 40°C / +85°C

Data Transmission

10 BaseT, 100 BaseTX and 1000 BaseT networks
Cat 5e per TIA/EIA 568B and ClassD per ISO/IEC 11801

Part Number Code

Series	RJF EZ	2	2	03 100BTX
RJField EZ - Lever				
Shell Type				
6:	Composite Lever Plug, Plastic Gland			
2:	Composite Square Flange Receptacle			
Back Terminations (For Receptacles only)				
1:	Female RJ45			
2:	RJ45 Cordset			
Cordset Length (For Receptacles with "2" Back Termination only)				
03 100BTX:	0.3m [11.81 inches]			
05 100BTX:	0.5m [19.68 inches]			
10 100BTX:	1m [39.37 inches]			
15 100BTX:	1.5m [59.05 inches]			

Remark: Cabling configuration: 100 BTX = 568B (Ethernet specification)

- Examples:
- Plug: RJF EZ 6
 - Receptacle, Female RJ45 Back termination: RJF EZ 21
 - Receptacle, 1,5m [59.05"] 100 BTX cordset termination: RJF EZ 22 15 100BTX

Plug

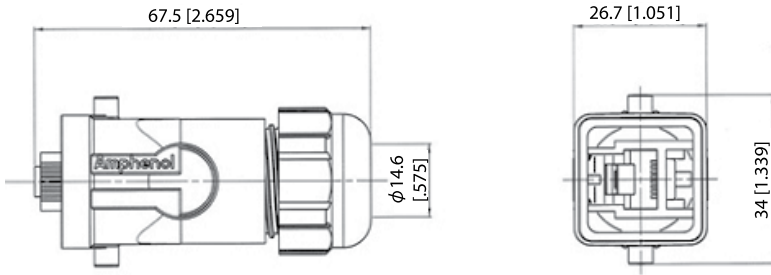

Receptacles

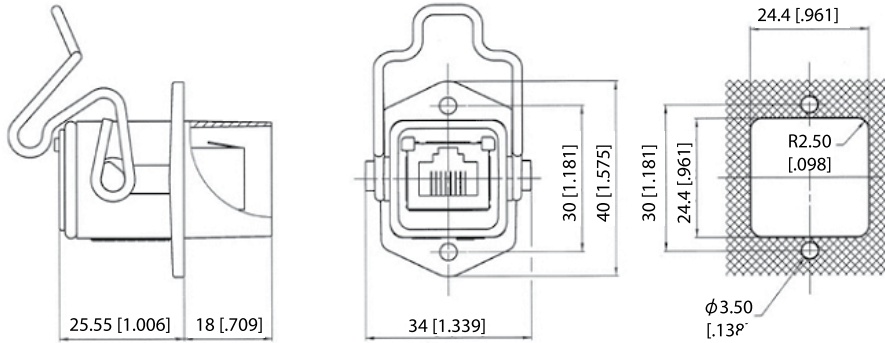

Back terminations

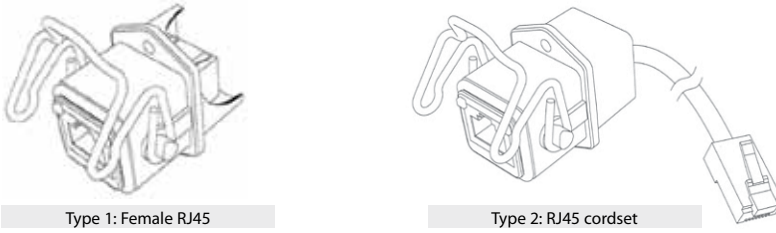

Type 1: Female RJ45

Type 2: RJ45 cordset

Notes: Type 2 without RJ45 plug at the end of the cable is also available: consult factory

Assembly Instructions

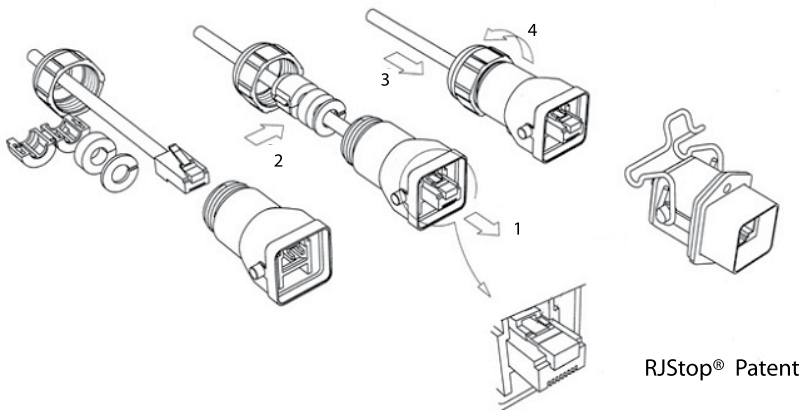

RJStop® Patent

Accessories

- IP68 Dust Caps
For Plugs: Not available
For Receptacles: RJF EZ BE



- Panel Gasket
Thickness: 1 mm [.039]
Part No. RJF EZ JE



RJF

Ethernet Connection System for Harsh Environment – Industrial Ethernet



RJF allows you to use an Ethernet Class D / Cat. 5e connection for 10 BaseT, 100 BaseTX or 1000 BaseT networks in harsh environments. With the patented RJStop® system you can use a standard RJ45 cordset in a **metallic** plug which will protect it from shocks, dust and fluids. **No hazardous on-field cabling and grounding!**

Applications

- Robotics
- Industrial Process Control
- CNC Machines
- Special Machines
- Oil & Gas
- Motion Control
- Data Acquisition and Transmission in Harsh Environment
- Tele-maintenance

Data Transmission

10 BaseT, 100 BaseTX and 1000 BaseT networks
Cat 5e per TIA/EIA 568B and ClassD per ISO/IEC 11801

Main characteristics

- Compliant with IEC 60603-7 variante 11
- **Bayonet coupling** ("Audible & Visual" coupling signal)
- **Robust metallic shells based on MIL-DTL-26482 H**
- RJ45 cordset retention in the plug: 100 N in the axis
- Mating cycles: 500 min
- Sealed against fluids and dust (IP68)
- Shock, Vibration and Traction resistant
- No cabling operation in field and no tools required
- Mechanical Coding / Polarization (4 positions)
- Compatible with cable diameter from 6 mm [0.236 in] to 13 mm [0.512 in]
For smaller diameters, please consult us.

Environmental Protection

- Sealing: IP68
- Salt Spray: 48 h with Nickel plating
> 96 h with Black coating
< 500 h with Olive drab cadmium
- Fire Retardant/Low Smoke: UL94 V0 and NF F 16 101 & 16 102
- Vibrations: 10 - 500 Hz, 10 g, 3 axes: no discontinuity > 10 nano s
- Shocks: IK06: weight of 250 g drop from 40 cm [15.75 in] onto connectors (mated pair)
- Humidity: 21 days, 43°C, 98% humidity
- Thermal Shock: 5 cycles at -40°C / +100°C
- Temperature Range: -40°C / +85°C

Part Number Code

Series RJField	RJF	2	2	B	03 100BTX
Shell Type					
6: Plug, Plastic Gland					
6M: Plug, Metal Gland					
2: Square Flange Receptacle					
2PE: Square Flange Receptacle, IP68 backshell, Plastic gland					
2PEM: Square Flange Receptacle, IP68 backshell, Metal gland					
7: Jam Nut Receptacle					
7PE: Jam Nut Receptacle, IP68 backshell, Plastic gland					
7PEM: Jam Nut Receptacle, IP68 backshell, Metal gland					
2SA, 7SA: Transversally sealed receptacle (unmated) see page 34					
Back Terminations (For Receptacles only)					
1: Female RJ45					
1RA: Right Angle Female RJ45					
2: RJ45 Cordset					
Shell Finishes					
B: Black Coating - ROHS compliant					
N: Nickel (Note: with this version, the inserts are metallized) - ROHS compliant					
G: Olive Drab Cadmium (Note: with this version, the inserts are metallized)					
Cordset Length (For Receptacles with "2" Back Termination only)					
03 100 BTX: 0.3m [11.81 inches]					
05 100 BTX: 0.5m [19.68 inches]					
10 100 BTX: 1m [39.37 inches]					
15 100 BTX: 1.5m [59.05 inches]					
00: 8 tinned holes at the rear of the PCB to solder the cable					

Remark: Cabling configuration: 100 BTX = 568B (Ethernet specification)

- Examples:**
- Nickel plug: RJF 6 N
 - Black square flange receptacle, female RJ45 back termination: RJF 2 1 B
 - Olive drab cadmium jam nut receptacle, 1.5m [59.05"] 100 BTX cordset termination: RJF 7 2 G 15 100BTX
 - Black in line square flange receptacle, 30cm [11.81"] 100BTX cordset termination: RJF 2PE 2 B 03 100BTX
 - Nickel jam nut receptacle, solder termination: RJF 72 N 00

Plug

- Shell type 6 with Plastic or Metal Gland

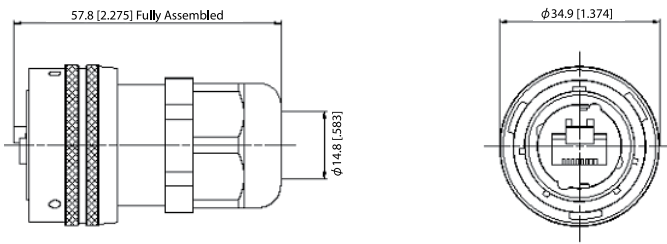

Receptacles

- Square flange receptacle • 4 mounting holes: Shell type 2

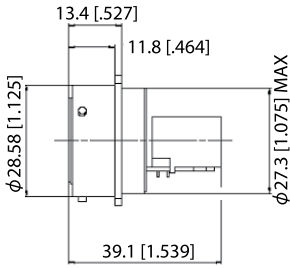

RJF 21 X (Straight Female RJ45)

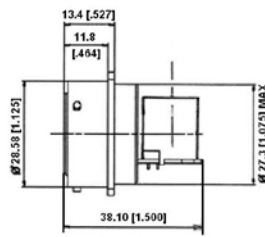

RJF 21 RA X (Right Angle Female RJ45)

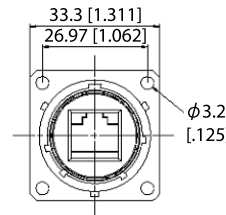

Panel Drilling

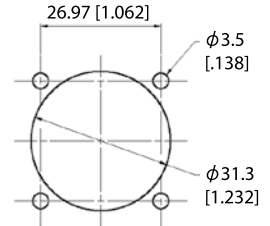

- Jam nut receptacle • Hexagonal Nut mounting: Shell type 7

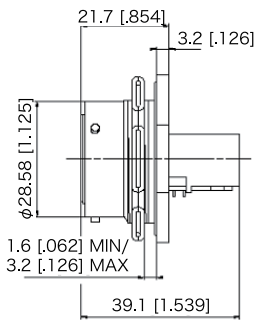

RJF 71 X (Straight Female RJ45)

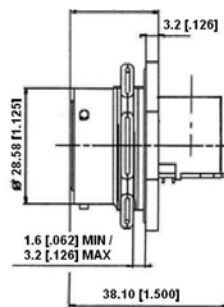

RJF 71 RA X (Right Angle Female RJ45)

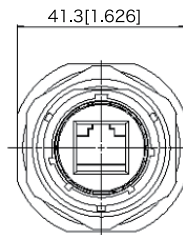

Panel Drilling

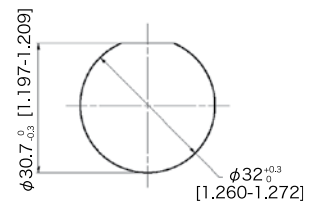

- Receptacles with IP68 backshell : Shell type 2PE and 7PE with Plastic or Metal Gland

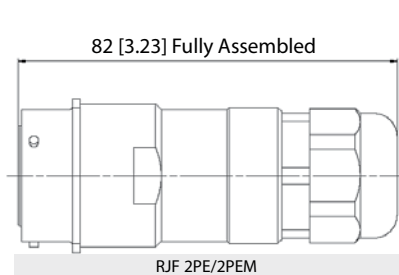

RJF 2PE/2PEM

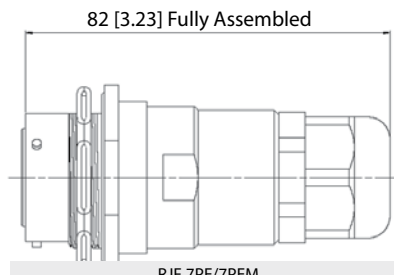

RJF 7PE/7PEM

Back terminations

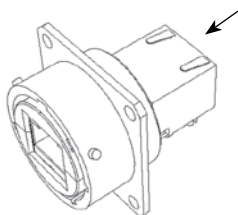

Type 1: Female RJ45

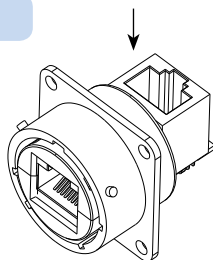

Type 1RA: Right Angle Female RJ45

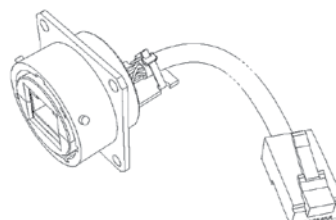

Type 2: RJ45 Cordset

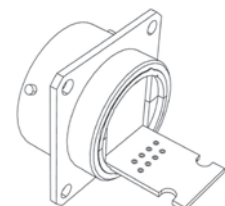

Type 2 - 00: Solder - 8 tinned holes

Notes: Type 2 without RJ45 plug at the end of the cable is also available: consult factory

Universal: Can be used with all standard RJ45 Cat.5e cordset brands

Assembly instructions

1. Push down the RJ45 cordset latch, and fix it inside the insert
2. Press in and click the other part of the insert
3. Insert in the metallic housing

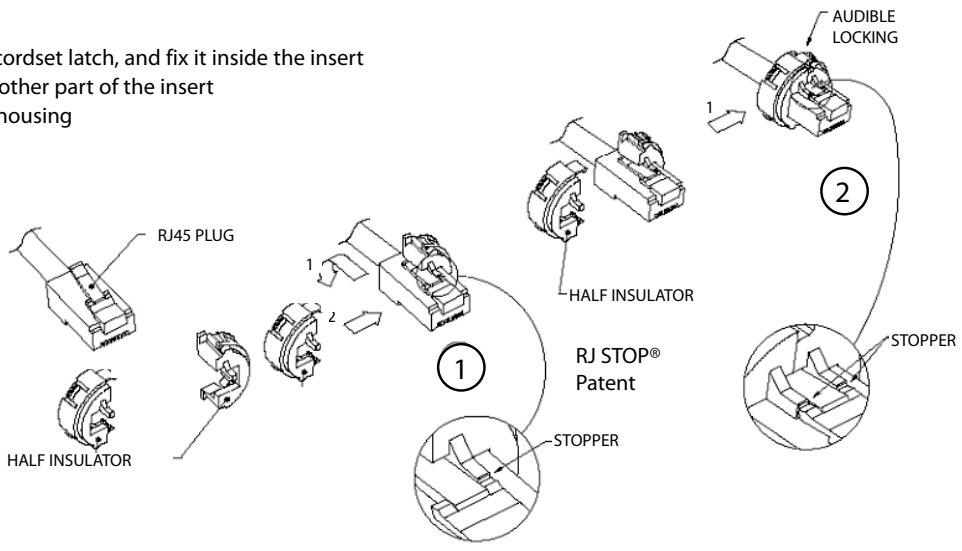

Easy and Safe: No field cabling tools required

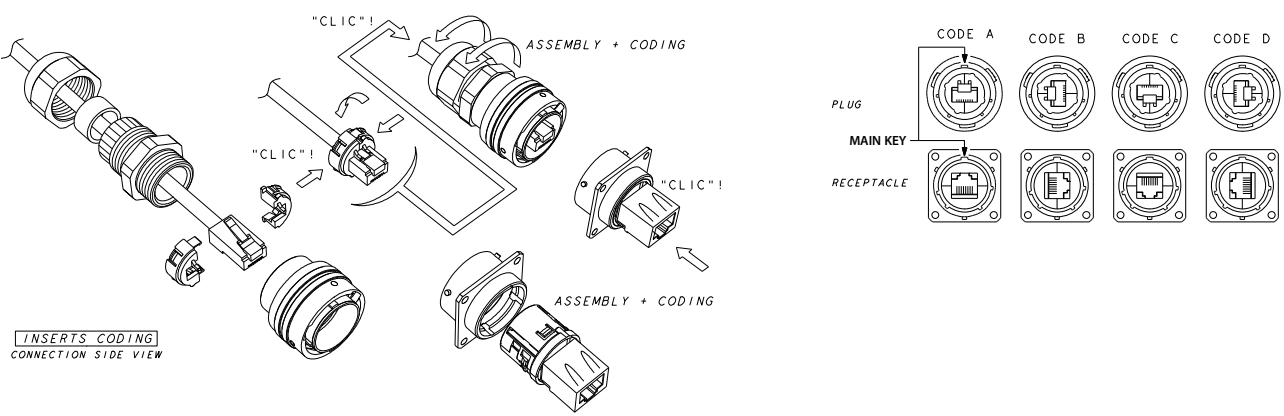

Accessories

■ Metallic cap

	RJFC	2	B
Connector Type			
6: Plug			
2: Square Flange Receptacle			
7: Jam Nut Receptacle			
Shell Finishes			
B: Black Coating - ROHS compliant			
N: Nickel - ROHS compliant			
G: Olive Drab Cadmium			

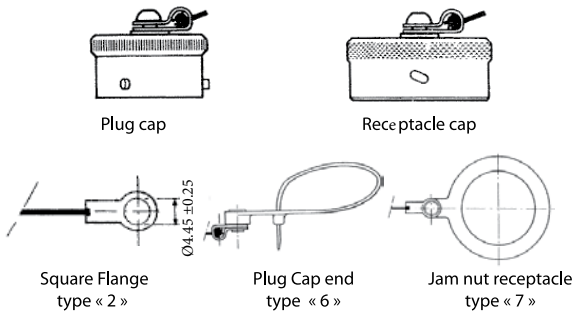

- Panel gasket for square flange 2 »thickness: 0,6 mm – P/N: JE 18



- Insert removal tool for receptacle and plug P/N = RJF ODE



RJF

Special Receptacles: Cable mount inline & PC tails

Inline Cable Mount Receptacles

Inline receptacles allow you to make cable extensions in the field by using them with rugged RJ Field series plugs.

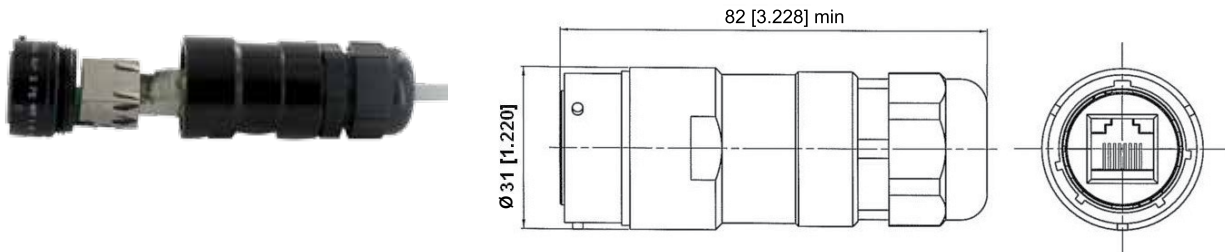

Part number	Plating	Plastic Gland	Metallic Gland
	Black coating	RJF2PEWF1B	RJF2PEMF1B
Nickel	RJF2PEWF1N	RJF2PEMF1N	
Olive Drab Cadmium	RJF2PEWF1G	RJF2PEMF1G	

PC Tails Receptacles

These receptacles can be soldered directly on your PCB. A compound insures a transversal sealing and good performance in high vibration environments. They can be connected with rugged RJField series plugs.

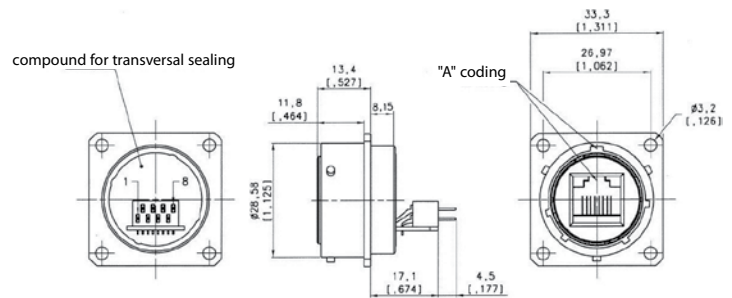

PCB LAYOUT - SOLDER FACE VIEW

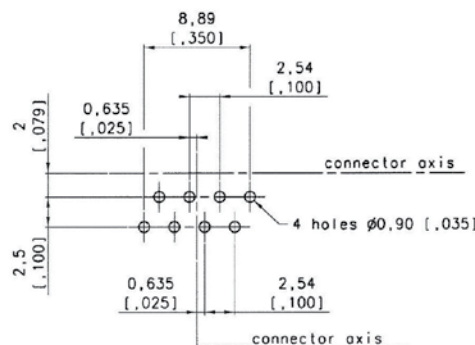

Panel Drilling

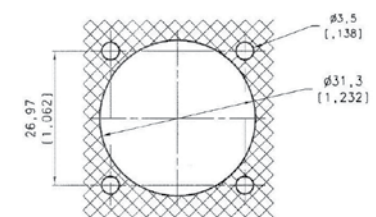

Part number	Plating available	Part number
	Black coating	RJF 2S X 5B
Nickel	RJF 2S X 5N	
Olive drab cadmium	RJF 2S X 5G	

X to be replaced by the letter of the coding position you need (A, B, C, or D) ▶

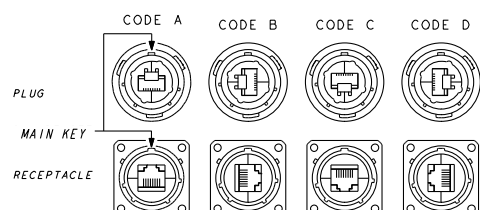



RJF

Receptacles - Plugs with 360° EMI backshell

RJF series receptacles and plugs with EMI backshells provide a solution with 360° shielding: same protection than the one proposed by standard MIL-DTL-26482H connectors. With those solutions we recommend using our reinforced and double shielded cat5E cable, see page 39.

Square Flange Receptacle *Straight Backshell*

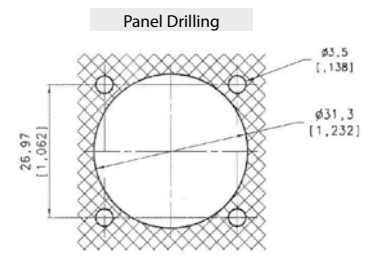
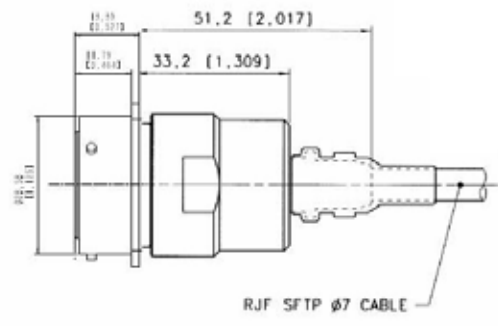

Part Number	Plating	Part number
	Nickel	Kit30439NI
	Olive Drab Cadmium	Kit30439

Kit30439 & Kit30439NI include:

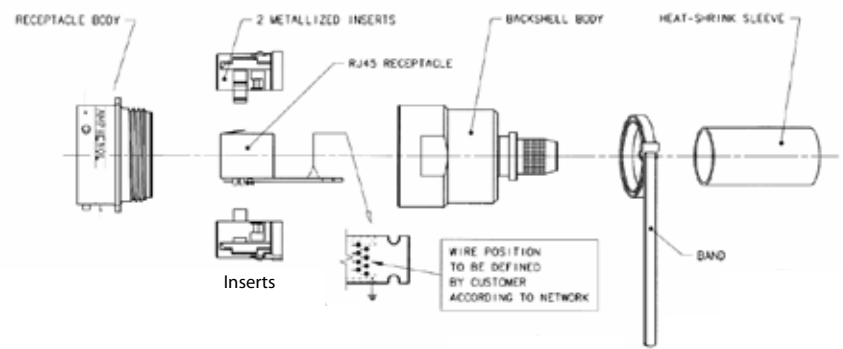

Plug *Straight Backshell*

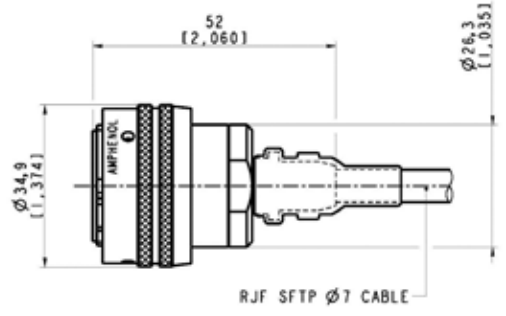

Part number	Plating	Part number
	Nickel	Kit30394NI
	Olive Drab Cadmium	Kit30394

Kit30394 & Kit30394NI include:

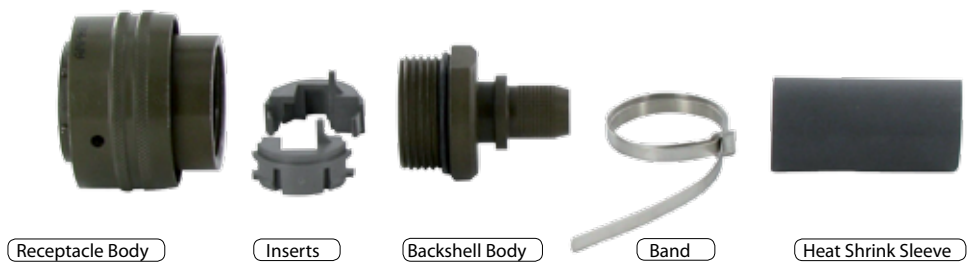

NEW

RJF

Special plug for big insulation wire up to 1.6 mm [0.062 in]



Rugged plug dedicated to cable with insulation wire from 1,1 to 1,6 mm [from 0.043 in to 0.062 in]

Remark:

- Solution compatible with any RJF receptacle
- For cables which are not compatible with standard RJ45 plug.

Applications

- Robotics
- Industrial Process Control
- CNC Machines
- Special Machines
- Oil & Gas
- Motion Control
- Data Acquisition and Transmission in Harsh Environment
- Tele-maintenance

Main characteristics

- **Bayonet coupling** ("Audible & Visual" coupling signal)
- **Robust metallic shells based on MIL-DTL-26482 H**
- RJ45 cordset retention in the plug: 100 N in the axis
- Mating cycles: 500 min
- Sealed against fluids and dust (IP68)
- Shock, Vibration and Traction resistant
- Mechanical Coding / Polarization (4 positions)
- Compatible with cable diameter from 6 mm [0.216 in] to 13 mm [0.512 in], for smaller diameters, please consult us

Environmental Protection

- Sealing: IP68
- Salt Spray: 48 h with Nickel plating
> 96 h with black coating
> 500 h with Oliv Drab Cadmium
- Fire Retardant/Low Smoke: UL94 V0 and NF F 16 101 & 16 102
- Vibrations: 10 – 500 Hz, 10 g, 3 axes: no discontinuity >10 nano s.
- Shocks: IK06: weight of 250 g drop from 40 cm [15.75 in] onto connectors (mated pair)
- Humidity: 21 days, 43°C, 98% humidity
- Thermal Shock: 5 cycles at - 40°C / +100°C
- Temperature Range: - 40°C / +85°C

Data Transmission

10 BaseT, 100 BaseTX and 1000 BaseT networks
Cat 5e per TIA/EIA 568B and ClassD per ISO/IEC 11801

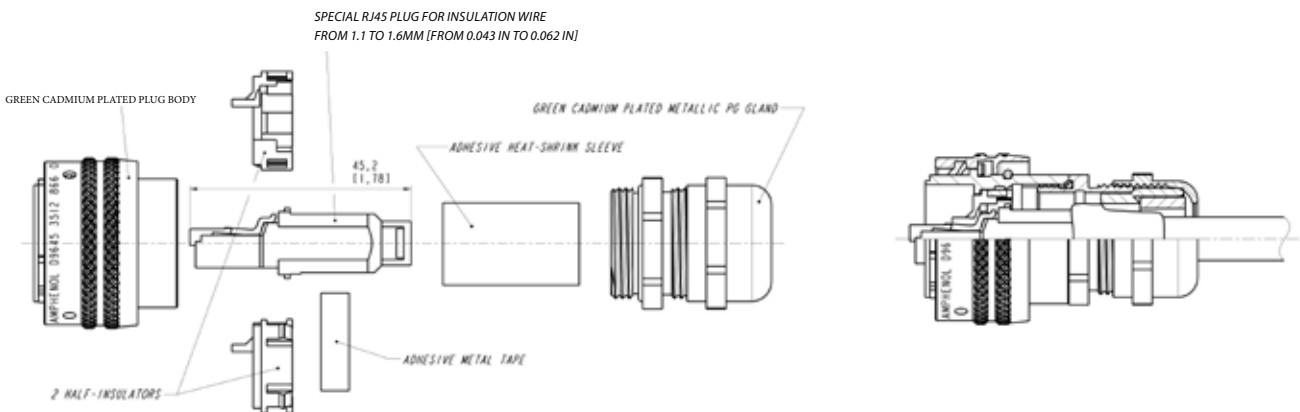

Part number	Plating	Part number
	Nickel	Kit39992NI
	Olive Drab Cadmium	Kit39992G

SELF CLOSING CAP

For RJ Field Receptacles

Sealing level IP54
(Splash and dust Proof)



This kit includes a receptacle and a Self Closing Cap which protects the RJ Field square flange receptacles (MIL-C-26482 type). This cap offers a protection against dust and water projections. A spring automatically closes the upper part of the cap when either the RJfield plug, USB or IEEE1394 cordset, or USB key are removed from the receptacle.

RJF 21 X SCC

RJ45 version

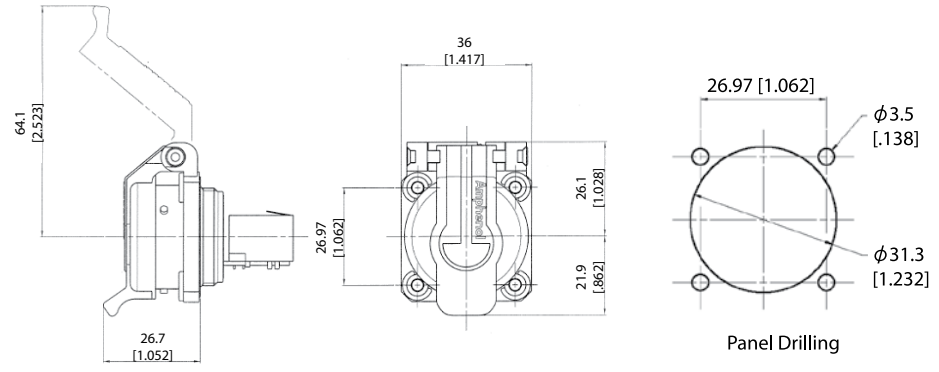

Part number *	Plating	Metallized insert (EMI)	Part number
	Black coating	No	RJF 21B SCC
	Nickel	Yes	RJF 21N SCC
	Olive drab cadmium	Yes	RJF 21G SCC

* The part number includes the receptacle + the self closing cap

Remark: could be used with our RJF series plug: part number RJF6xx (see page 17).

Note: Panel gasket with any of these receptacles: JE18



USBF 21 x SCC, USBBF 21 x SCC, & IEEE1394



USB-A version
(see page 83)



USB-B version
(see page 92)



IEEE1394 version
(see page 117)



RJF TV

Ethernet Connection System for Harsh Environment



RJF TV allows you to use an Ethernet Class D / Cat. 5e connection for 10 BaseT, 100 BaseTx or 1000 BaseT networks in harsh environments. With the patented RJStop system you can use a standard RJ45 cordset in a **metallic** plug which will protect it from shocks, dust and fluids. **No hazardous on-field cabling and grounding!**

Applications

- Data Acquisition and Transmission in harsh environment
- Railways
- Radars
- Shelters
- Battlefield Communication
- Systems
- Navy

Data Transmission

10 BaseT, 100 BaseTX and 1000 BaseT networks
Cat 5e per TIA/EIA 568B and ClassD per ISO/IEC 11801

Main characteristics

- Sealed against fluids and dusts (IP68)
- Shock, Vibration and Traction resistant
- No cabling operation in field and no tools required
- Mechanical Coding / Polarization (4 positions)
- Improved EMI protection
- **Tri Start Thread coupling mechanism (MIL-DTL-38999 series III type) with anti-decoupling device**
- **Robust metallic shells**
- RJ45 cordset retention in the plug: 100 N in the axis
- Mating cycles: 500 min
- Compatible with cable diameter from 6 mm [0.236 in] to 13 mm [0.512 in], for smaller diameters please consult us

Environmental Protection

- Sealing: IP68
- Salt Spray: 48h with Aluminium shell - Nickel plating
> 500h with Aluminium shell - Olive drab cadmium plating
1000 h with Marine bronze shell
- Fire Retardant/Low Smoke : UL94 V0 and NF F 16 101 & 16 102
- Vibrations : 10 - 500 Hz, 10 g, 3 axes: no discontinuity > 10 nano s.
- Compounded versions tested per NAS 1599 (5-3000 Hz, 20g, 12h)
- Shocks: IK06: weight of 250 g drop from 40 cm [15.75 in] onto connectors (mated pair)
- Humidity: 21 days, 43°C, 98% humidity
- Thermal Shock: 5 cycles at -40°C / +100°C
- Temperature Range: -40°C / +85°C

Part Number Code

Series RJ Field TV	RJF TV	2	2	G	03 100 BTX
Shell Type					
6:	Plug with Plastic gland				
6M:	Plug with Metal gland				
2:	Square Flange Receptacle				
2PE:	Square Flange Receptacle, IP68 backshell, Plastic gland				
2PEM:	Square Flange Receptacle, IP68 backshell, Metal gland				
7:	Jam Nut Receptacle				
7PE:	Jam Nut Receptacle, IP68 backshell, Plastic gland				
7PEM:	Jam Nut Receptacle, IP68 backshell, Metal gland				
2SA, 7SA:	Transversally sealed receptacle (unmated) see page 34				
Back Terminations (Receptacles only)					
1:	Female RJ45				
1RA:	Right Angle Female RJ45				
2:	RJ45 Cordset				
Shells material & Finish					
N:	Aluminium shell - nickel plating (receptacle inserts are metallized) - ROHS compliant				
G:	Aluminium shell - olive drab cadmium plating (receptacle inserts are metallized)				
BZ:	Marine bronze shell (receptacle inserts are metallized) - ROHS compliant				
Cordset Length (type 2 back termination only)					
03 100 BTX:	0.3m [11.81 inches]				
05 100 BTX:	0.5m 19.68 inches]				
10 100 BTX:	1m [39.37 inches]				
15 100 BTX:	1.5m [59.05 inches]				
00:	8 tinned holes at the rear of the PCB to solder the cable				
Remark: Cabling configuration:	100 BTX = 568B (Ethernet specification)				

- Examples:**
- Olive Drab Cadmium plug with plastic gland: RJF TV 6G
 - Olive Drab Cadmium Jam Nut Receptacle, female RJ45 back termination: RJF TV 71G
 - Nickel Jam Nut Receptacle, 1,5 m 100 BTX cordset back termination: RJF TV 72N 15 100BTX
 - Olive Drab Cadmium in line Square Flange Recept., 0,3 m 100 BTX cordset back termination: RJF TV 2PE 2 G 03 100BTX
 - Nickel Jam Nut Receptacle Solder termination 8 tinned holes: RJF TV 22 N 00

Plug

- Shell type 6 with Plastic or Metal Gland

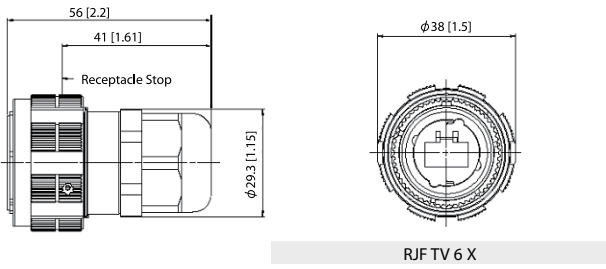

Receptacles

- Square flange receptacle - 4 mounting holes: Shell type 2

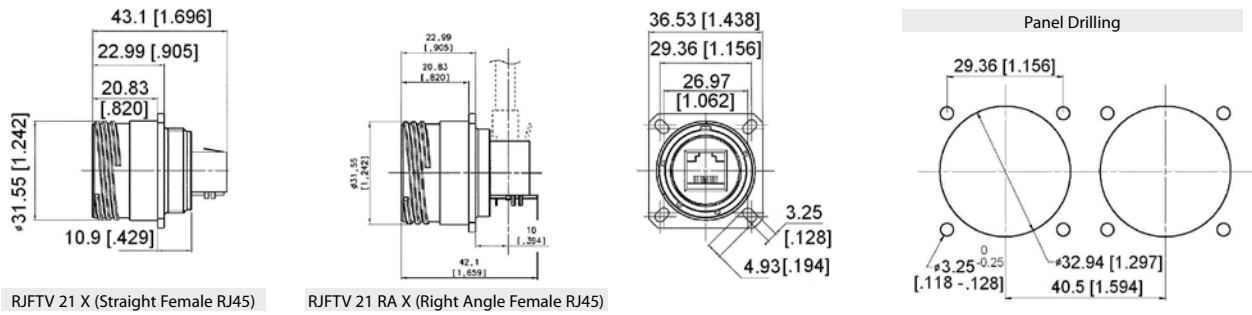

- Jam nut receptacle - Hexagonal Nut mounting: Shell type 7

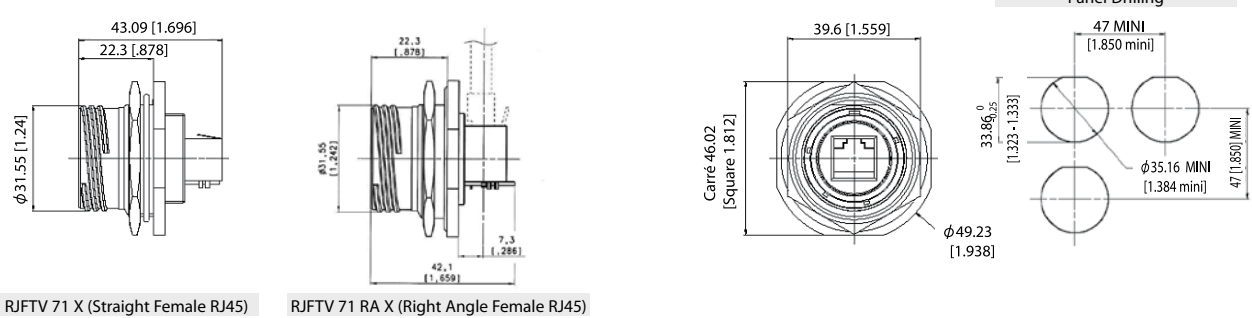

- Receptacles with IP68 backshell: Shell type 2PE and 7PE with Plastic or Metal Gland

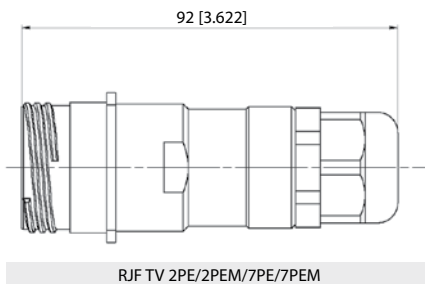

Back terminations

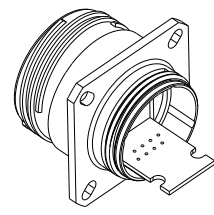
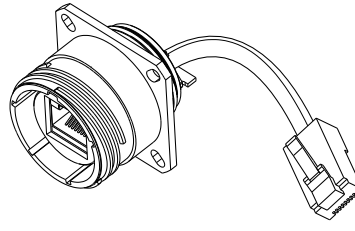
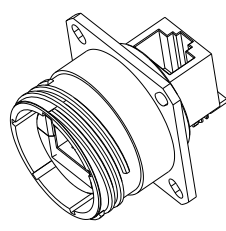
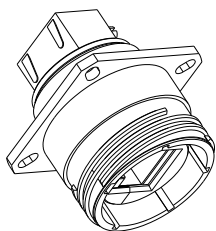

Notes Type 2 without RJ45 plug at the end of the cable is also available: consult factory

Assembly instructions

Insert Codings

CONNECTION SIDE VIEW

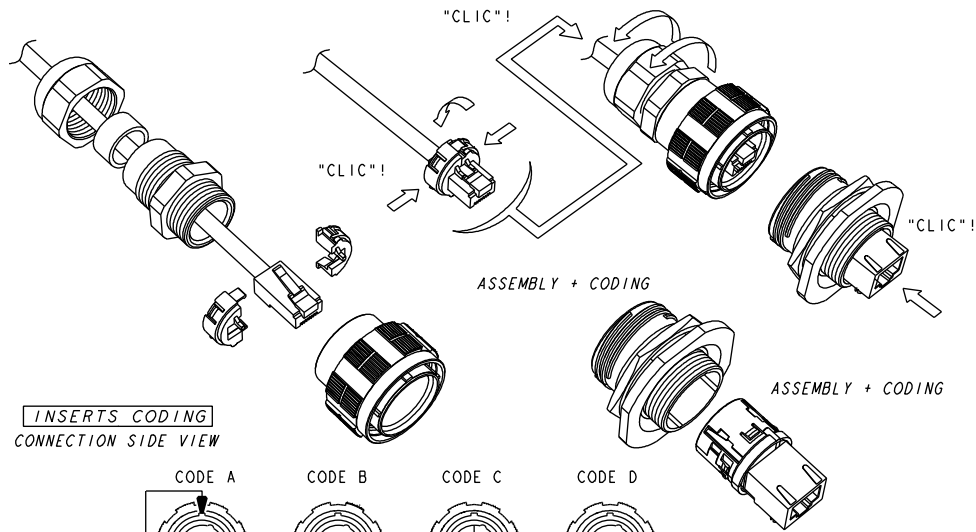

Accessories

■ Metallic Caps

	RJFTVC	2	M	G
Connector Type				
6:	Plug			
2:	Square Flange Receptacle			
7:	Jam Nut Receptacle			
Wire type				
Blank	for Nylon cord			
M:	metal chain			
Shell Material & finish				
N:	Aluminium shell - nickel plating - ROHS compliant			
G:	Aluminium shell - olive drab cadmium plating			
BZ:	Marine bronze shell - ROHS compliant			

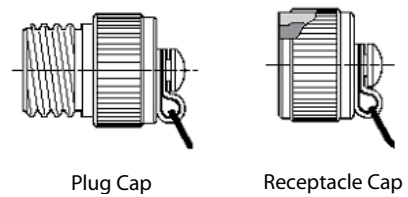

Plug Cap

Receptacle Cap

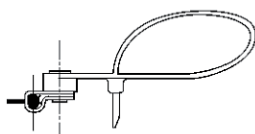

Plug Cap end

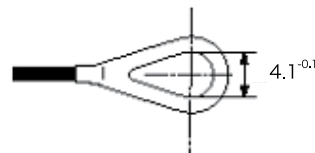

Square flange receptacle cap end

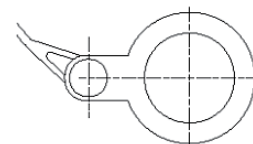

Jam Nut receptacle cap end

- Panel Gasket for square flange receptacle
(Thickness: 0,8 mm [.031]): JE19



- Insert removal tool: RJF ODE



RJFTV

Self Closing Cap (SCC series)

This Self Closing cap automatically protects the RJF TV square flange receptacle (MIL-DTL-38999 type), protecting your system from dust and water projection. A spring automatically closes the upper part of the cap when the RJF TV plug is removed from the receptacle.

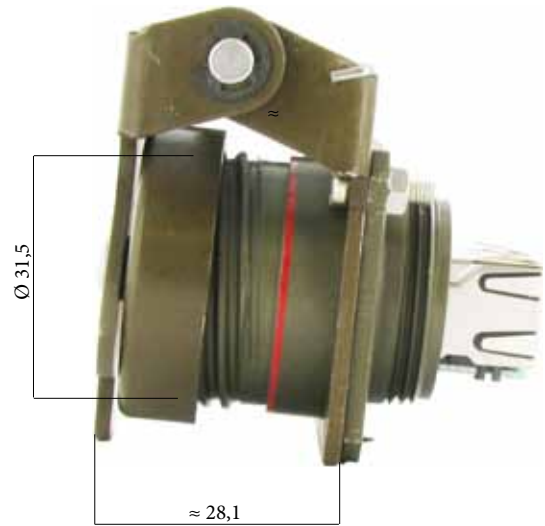
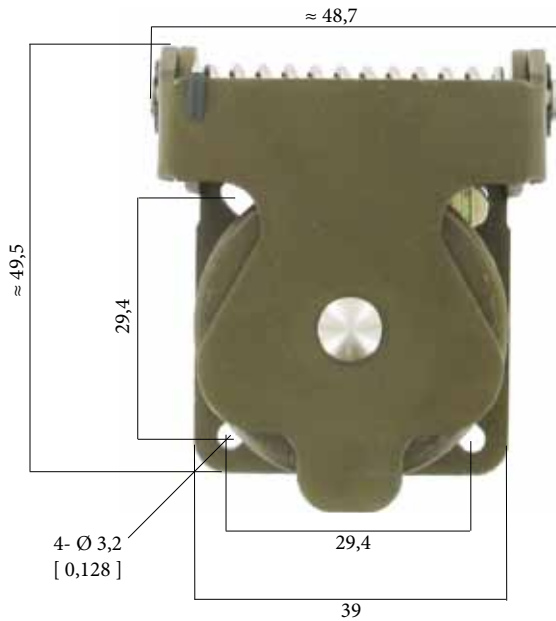

IMPORTANT NOTE

Metal Self Closing cap are sold separately (without receptacle).



Part number	Plating	Part number
	Black coating	RJF TV SCC B
	Nickel	RJF TV SCC N
	Olive drab cadmium	RJFTV SCC G

Remark: compatible with RJFTV square flange receptacle type RJFTV2xxx only (see page 24).

- Panel Gasket for square flange receptacle (Thickness: 0,8 mm [.031])

Part number: JE19



RJF TV

Receptacles - Plugs with 360° EMI backshells



RJFTV series receptacles and plugs with EMI backshells provide a solution with 360° shielding: same protection than the one proposed by standard MIL-DTL-38999 series III connectors. With those solutions we recommend using our reinforced and double shielded cat5E cable, see page 39.

Square Flange Receptacle *Straight Backshell*

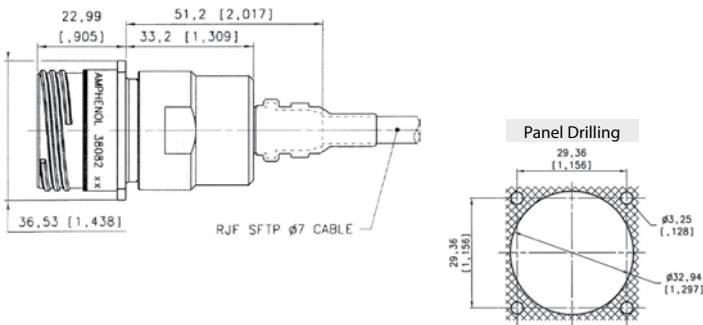

Part number	Plating	Part number
	Nickel	
	Olive drab cadmium	Kit38082

Square Flange Receptacle *Right Angle Backshell*

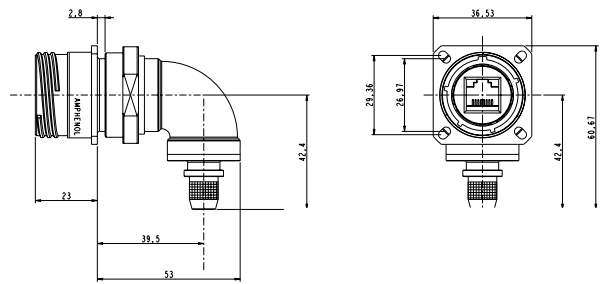

Part number	Plating	Part number
	Nickel	
	Olive drab cadmium	Kit40791

Kit38082, Kit38082NI, Kit40791 & Kit40791NI include:



Jam Nut Receptacle *Straight Backshell*

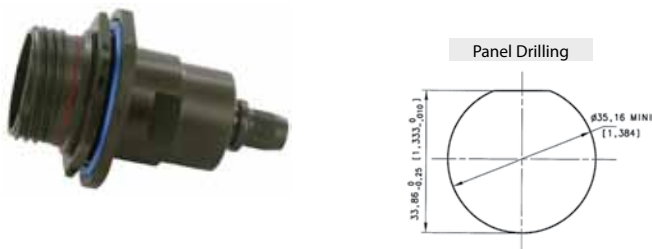

Part number	Plating	Part number
	Nickel	
	Olive drab cadmium	Kit38204

Jam Nut Receptacle *Right Angle Backshell*

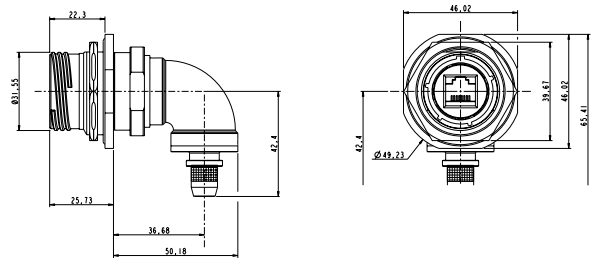

Part number	Plating	Part number
	Nickel	
	Olive drab cadmium	Kit40771

Kit38204, Kit38204NI, Kit40771 & Kit40771NI include:



IMPORTANT NOTE

With these receptacles, you will have to solder your own cable on the PCB. So the wire positions have to be defined according to your network.

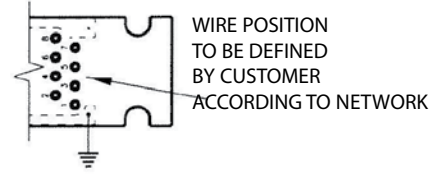

Plug Straight Backshell



Plug Right Angle Backshell

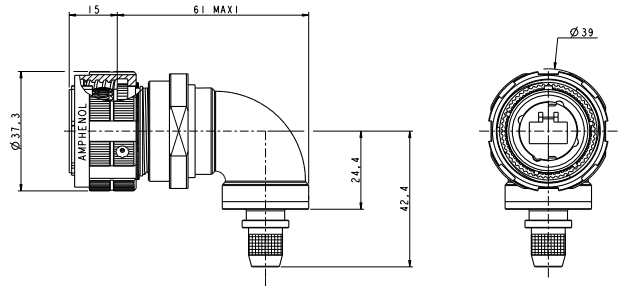

Part number	Plating	P/N
	Nickel	Kit38081NI
	Olive drab cadmium	Kit38081

Part number	Plating	P/N
	Nickel	Kit40792NI
	Olive drab cadmium	Kit40792

Kit38081, Kit38081NI, Kit40792 & Kit40792NI include:



IMPORTANT NOTE

With these plugs, the standard RJ45 plug is not provided. Customer will have to crimp a standard RJ45 on the cable by himself.

Remark: we advise using our double Shielded, reinforced Cat5E cable (see page 39) with these RJFTV series EMI connectors. If customer wants to use his own cable, please check with us regarding compatibility with our backshells: contact@rjfield.com. We also provide assembled cordsets (see examples below). For this type of solution please provide the configuration needed: length, description of second end...

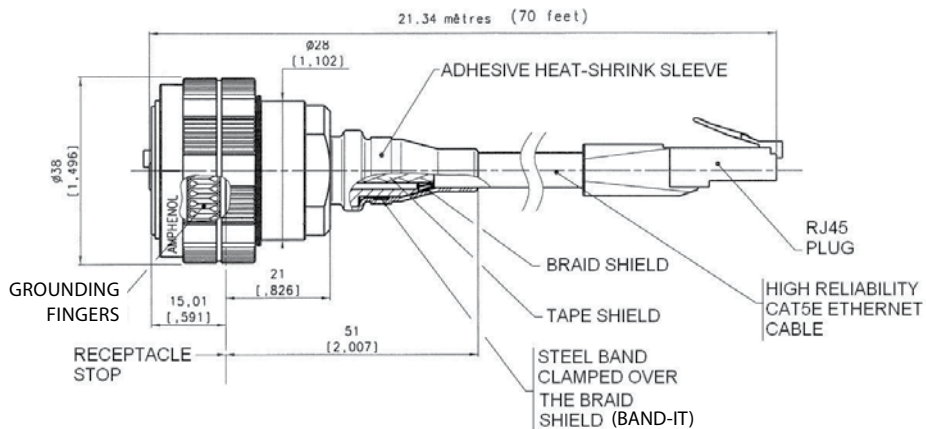

RJF TV

Through Bulkhead Receptacles

Our RJFTV through bulkhead receptacles can be connected on each side with rugged RJFTV plugs. This system allows mechanical protection and a sealing (IP68) inside and outside the equipment, and keeps the flexibility offered by panel mount and plug connectors. They can be connected with RJFTV series plugs.

Square flange receptacle

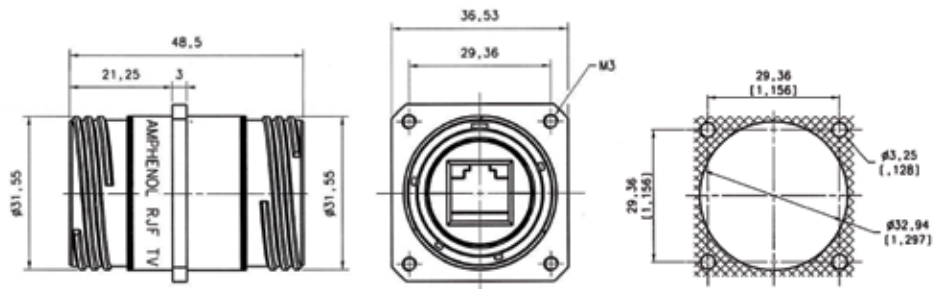

Part number	Plating	Metallized insert	Part number
	Nickel	No	RJF TV B 2 N ISO BRUT *
	Nickel	Yes	RJF TV B 2 N ISO NI *
	Olive Drab Cadmium	No	RJF TV B 2 G ISO BRUT *
	Olive Drab Cadmium	Yes	RJF TV B 2 G ISO NI *

* ISO BRUT = Non conductive insert
ISO NI = Conductive insert

Jam nut receptacle

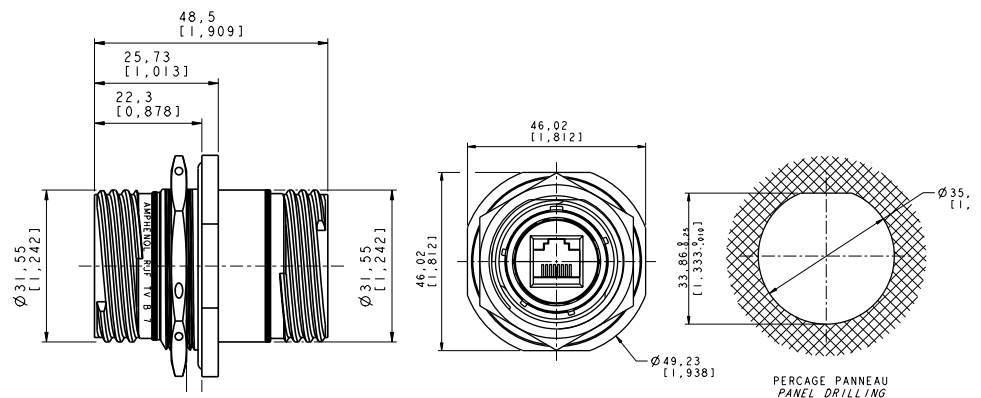

Part number	Plating	Metallized insert	Part number
	Nickel	No	RJF TV B 7 N ISO BRUT *
	Nickel	Yes	RJF TV B 7 N ISO NI *
	Olive Drab Cadmium	No	RJF TV B 7 G ISO BRUT *
	Olive Drab Cadmium	Yes	RJF TV B 7 G ISO NI *

* ISO BRUT = Non conductive insert
ISO NI = Conductive insert

RJF TV

Stand off Receptacles

These receptacles can be sold directly to your PCB.
 A compound insures a transversal sealing and good performance in high-vibration environments.
 The shell of those receptacles are in the "Stand Off" style.
 They can be connected with RJFTV series plugs.

Square flange receptacle

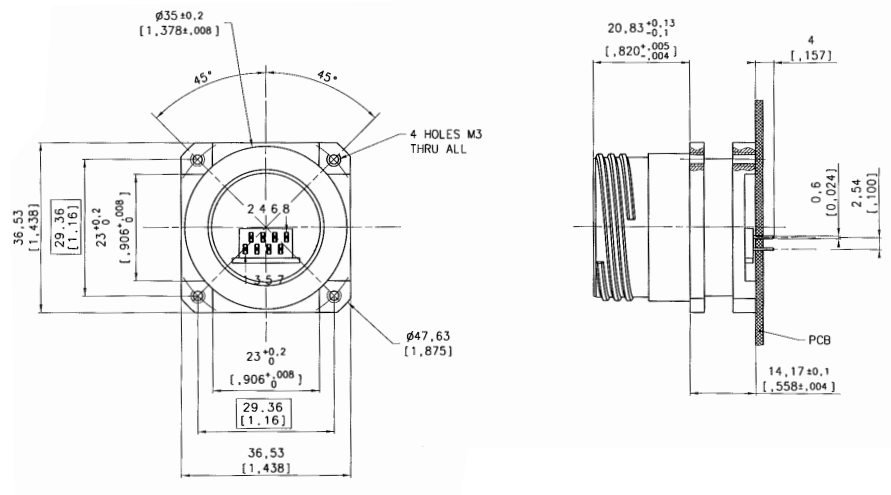

Part number	Plating available	Part number
	Nickel	RJF TV 2S X 5N F459
	Olive Drab Cadmium	RJF TV 2S X 5G F459

X to be replaced by the letter of the coding position you need (A, B, C, or D) ▶

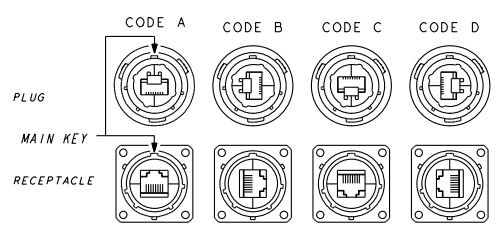

PCB LAYOUT

Solder face view

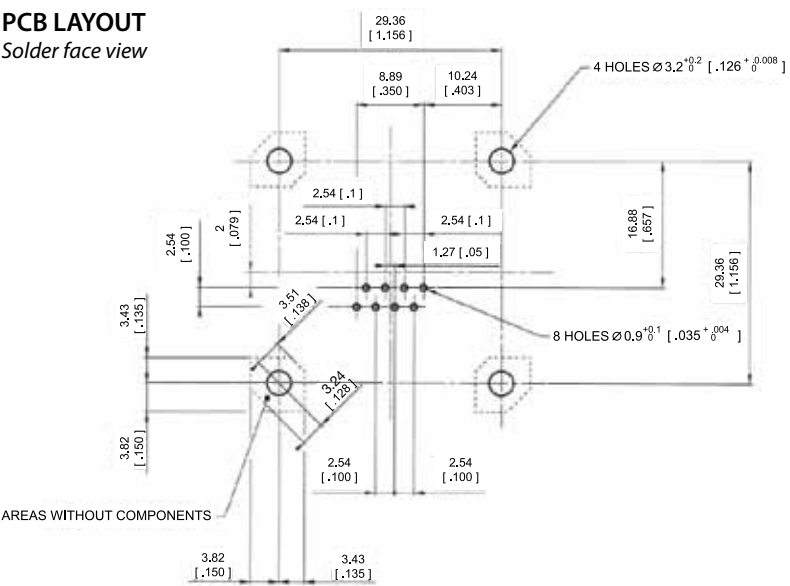

Panel Drilling

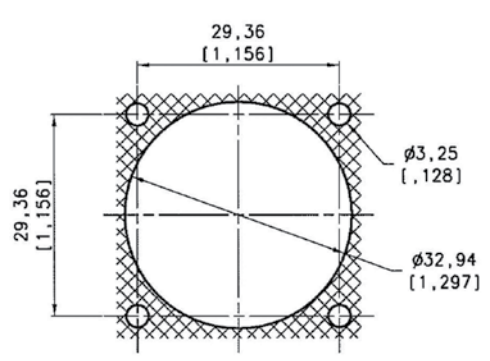

AREAS WITHOUT COMPONENTS



Now available with same distance between flange and PCB than the 38999 stand off one. So you can use a 38999 stand off and a RJ45 stand off in the same implementation.

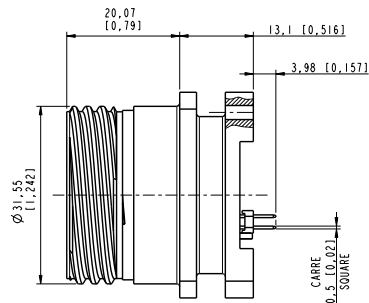
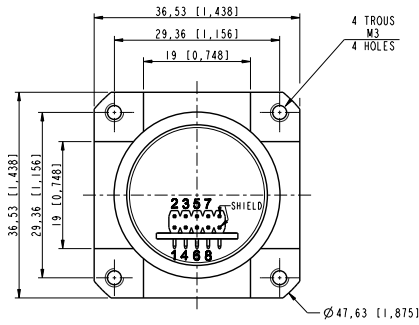

Part number: 36542

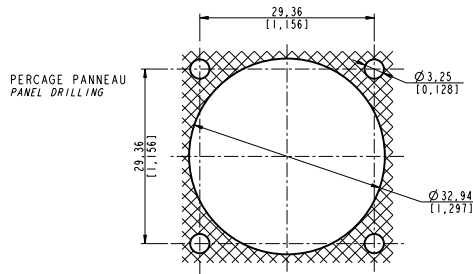
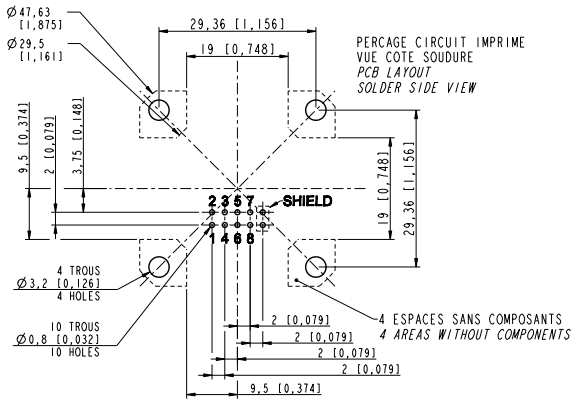

Jam nut receptacle

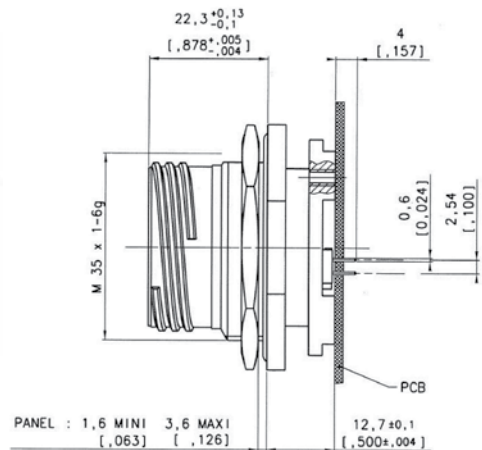
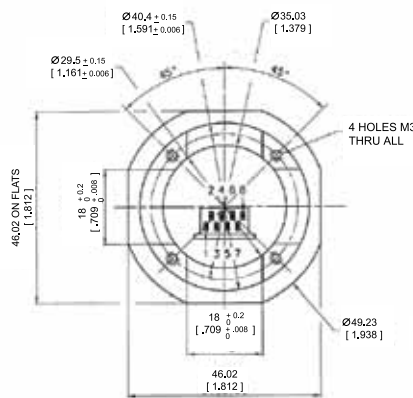

Part number	Plating available	Part number
	Nickel	RJF TV 7S X 5N F459
Olive Drab Cadmium	RJF TV 7S X 5G F459	

X to be replaced by the letter of the coding position you need (A, B, C, or D) ▷

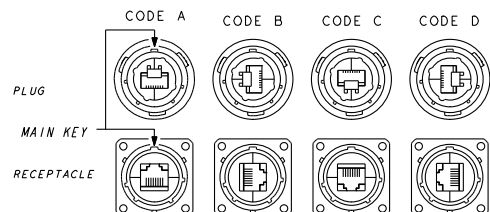

PCB LAYOUT

Solder side view

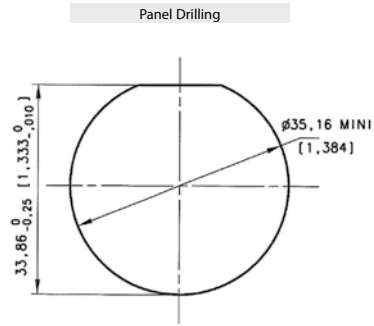
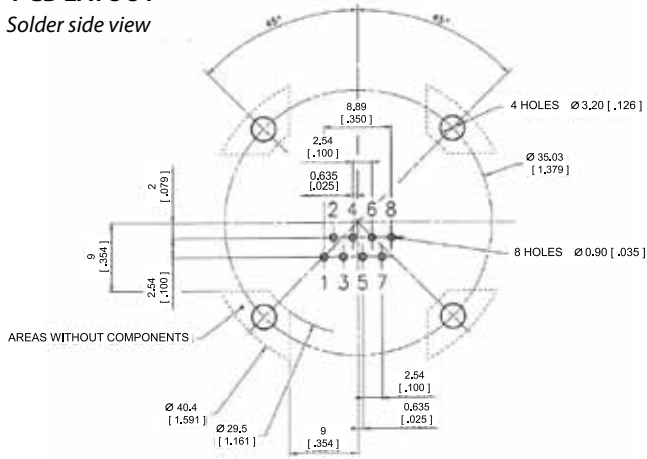

Now available with same distance between flange and PCB than the 38999 stand off one. So you can use a 38999 stand off and a RJ45 stand off in the same implementation.

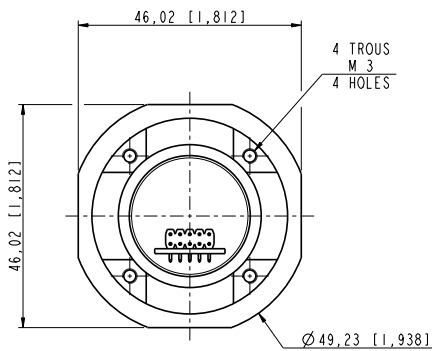

Part number: 36540

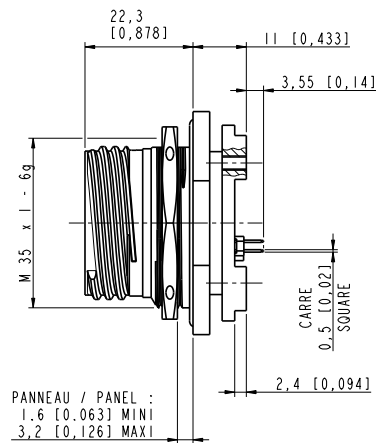

PCB LAYOUT

Solder side view

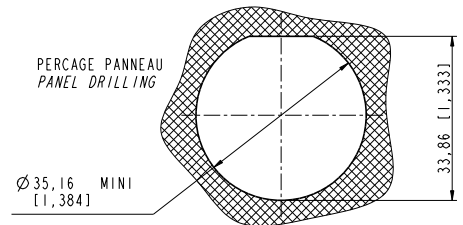
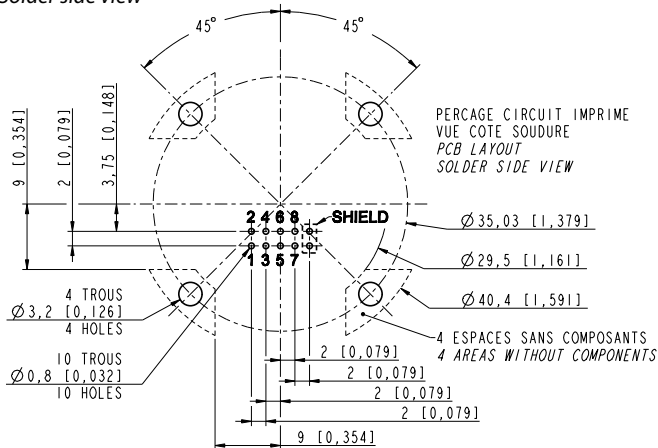

RJF/RJF TV

Environmentally Sealed Receptacles, Transversally sealed Receptacles



In some applications, a transversal sealing for the receptacle is a « must ». This will prevent fluids and dust from going through the receptacle when plug or cap are not mated to the receptacle.

The sealed solution (version "S") has a compound at the rear of the receptacle as shown on the examples below. This feature is available both in RJF and RJF TV shells (please consult the relevant data sheet for product details and accessories).

In addition, the Sealed RJF TV has been successfully tested in very high vibration corresponding to airplane applications.

- Applications**
- Outdoor Equipment
 - Airplanes Equipment
 - Tactical Radios
 - Shelters
 - Rugged computers
 - Data Acquisition and Transmission in Harsh Environments
- Data Transmission**
- 10 BaseT, 100 BaseTX and 1000 BaseT networks
Cat 5e per TIA/EIA 568B and ClassD per ISO/IEC 11801

- Main characteristics**
- Same as the RJF and RJF TV series... a complete IP68 sealing of the receptacle (even with no plug or no protective cap mated) is added.
 - Outside dimensions are the same as the standard RJF and RJF TV series.
 - Vibrations: the compounded versions of the RJF TV have been tested in vibration following the NAS 1599 Aeronautic specification (Ambient temperature):
5 - 3000 Hz, 20g, 2,5 mm [.1 inch] double amplitude, 3 axes, 12 hours
Note: This specification exceeds MIL-C-26500 requirements.

IMPORTANT NOTE

Due to the compound, the coding of the connector must be done in the factory : use the codes A, B, C or D in the part number: **see below**.

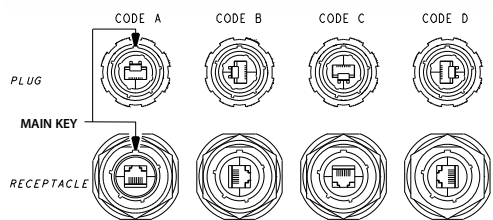

Example :
RJFTV 2S A2 G 15 100BTX

Part Number Code

Series		RJF TV	7S	A	2	G	03 100BTX
RJF:	MIL-DTL-26482 H bayonet						
RJFTV:	MIL-DTL-38999 Series III						
Shell Type							
2S:	Sealed Square Flange Receptacle						
7S:	Sealed Jam Nut Receptacle						
Coding							
A,B,C,D							
Back Terminations (For Receptacles only)							
1:	Female RJ45						
1RA:	Right Angle Female RJ45						
2:	RJ45 Cordset						
Shell material & Finish							
B:	Aluminium shell - black coating (Only available for RJF Series) - ROHS compliant						
N:	Aluminium shell - nickel plating - ROHS compliant (note: receptacle inserts are metallized)						
G:	Aluminium shell - olive drab cadmium plating (note: receptacle inserts are metallized)						
BZ:	Marine bronze shell (only available for RJFTV) (receptacle inserts are metallized) - ROHS compliant						
Cordset Length (For Receptacles with "2" Back Termination only)							
03 100 BTX:	0.3m [11.81 inches]						
05 100 BTX:	0.5m [19.68 inches]						
10 100 BTX:	1m [39.37 inches]						
15 100 BTX:	1.5m [59.05 inches]						

Remark: Cabling configuration: 100 BTX = 568B (Ethernet specification)

- Examples:
- Bayonet, A coding, Olive Drab Cadmium Jam Nut sealed receptacle with female RJ45 Back termination: RJF 7SA 1 G
 - Bayonet, A coding, Black square flange sealed receptacle, Female RJ45 Back termination: RJF 2SA 1 B
 - Series III, A coding, Olive Drab Cadmium Jam Nut sealed receptacle, 1.5m [59.05"] 100 BTX cordset: RJF TV 7SA 2 G15 100BTX

RJF/RJF TV

Hermetic receptacles



In some applications, a transversal hermiticity for the receptacle is a « must ». This will prevent gas from going through the receptacle when plug or cap are not mated to the receptacle. The hermetic solution (version "H") has a compound at the rear of the receptacle as shown on the examples below. This feature is available both in RJF and RJF TV shells (please consult the relevant data sheet for product details and accessories). Helium leakage is less than 1.10^{-6} cm³ per second [0.1 micron cubic ft per hour] at one bar [15 psi] pressure differential.

- Applications**
- Outdoor Equipment
 - Airplanes Equipment
 - Tactical Radios
 - Shelters
 - Rugged computers
 - Data Acquisition and Transmission in Harsh Environments

Data Transmission
10 BaseT, 100 BaseTX and 1000 BaseT networks
Cat 5e per TIA/EIA 568B and ClassD per ISO/IEC 11801

- Main characteristics**
- Same as the RJF and RJF TV series ... a complete IP68 sealing of the receptacle (even with no plug or no protective cap mated) is added.
 - Outside dimensions are the same as the standard RJF and RJF TV series.
 - Vibrations: The compounded versions of the RJF TV have been tested in vibration following the NAS 1599 Aeronautic specification (Ambient temperature):
5 - 3000 Hz, 20g, 2,5 mm [1 inch] double amplitude, 3 axes, 12 hours
Note: This specification exceeds MIL-C-26500 requirements.

IMPORTANT NOTE

Due to the compound, the coding of the connector must be done in the factory: use the codes A, B, C or D in the part number: **see below.**

PLUG

MAIN KEY

RECEPTACLE

CODE A

CODE B

CODE C

CODE D

Example :
RJFTV 2H A2 N 15 100BTX

Part Number Code

Series	RJF TV	7H	A	2	G	03 100BTX
RJF:	MIL-DTL-26482 H bayonet					
RJFTV:	MIL-DTL-38999 series III					
Shell Type						
2H:	Transversally Sealed and Hermetic Square Flange Receptacle					
7H:	Transversally Sealed and Hermetic Jam Nut Receptacle					
Coding						
A,B,C,D						
Back Terminations (For Receptacles only)						
1:	Female RJ45					
1RA:	Right Angle Female RJ45					
2:	RJ45 Cordset					
Shell material & Finish						
B:	Aluminium shell - black coating (Only available for RJF Series) - ROHS compliant					
N:	Aluminium shell - nickel plating - ROHS compliant (note: receptacle inserts are metallized)					
G:	Aluminium shell - olive drab cadmium plating (note: receptacle inserts are metallized)					
BZ:	Marine bronze shell (only available for RJFTV) (receptacle inserts are metallized) - ROHS compliant					
Cordset Length (For Receptacles with "2" Back Termination only)						
03 100 BTX:	0.3m [11.81 inches]					
05 100 BTX:	0.5m [19.68 inches]					
10 100 BTX:	1m [39.37 inches]					
15 100 BTX:	1.5m [59.05 inches]					

Remark: Cabling configuration: 100 BTX = 568B (Ethernet specification)

- Examples:
- Bayonet, A coding, Olive Drab Cadmium Jam Nut sealed receptacle with female RJ45 Back termination: RJF 7HA 1 G
 - Bayonet, A coding, Black square flange sealed receptacle, Female RJ45 Back termination: RJF 2HA 1 B
 - Series III, A coding, Olive Drab Cadmium Jam Nut sealed receptacle, 1.5m [59.05"] 100 BTX cordset: RJF TV 7HA 2 G15 100BTX

NEW

RJF TV

For big insulation wire up to 1.6 mm



Special RJF TV plug dedicated to Ethernet cable with insulation wire from 1,1 to 1,6 mm.

Remark:

- compatible with any RJF TV receptacle
- for cables which are not compatible with standard RJ45 plug

Applications

- Robotics
- Industrial Process Control
- CNC Machines
- Special Machines
- Oil & Gas
- Motion Control
- Data Acquisition and Transmission in Harsh Environment
- Tele-maintenance

Data transmission

10 BaseT, 100 BaseTX and 1000 BaseT networks
 Cat 5e per TIA/EIA 568B and ClassD per ISO/IEC 11801

Main characteristics

- Sealed against fluids and dusts (IP68)
- Shock, Vibration and Traction resistant
- No cabling operation in field and no tools required
- Mechanical Coding / Polarization (4 positions)
- Improved EMI protection
- **Tri Start Thread coupling mechanism (MIL-DTL-38999 series III type) with anti-decoupling device**
- **Robust metallic shells**
- RJ45 cordset retention in the plug: 100 N in the axis
- Mating cycles: 500 min
- Compatible with cable diameter from 6 mm [0.216 in] to 13 mm [0.512 in], for smaller diameters please consult us

Environmental protection

- Sealing: IP68
- Salt Spray: 48 h with Nickel plating
 > 96 h with black coating
 > 500 h with Oliv Drab Cadmium
- Fire Retardant/Low Smoke: UL94 V0 and NF F 16 101 & 16 102
- Vibrations: 10 – 500 Hz, 10 g, 3 axes: no discontinuity > 10 nano s.
- Shocks: IK06: weight of 250 g drop from 40 cm [15.75 in] onto connectors (mated pair)
- Humidity: 21 days, 43°C, 98% humidity
- Thermal Shock: 5 cycles at - 40°C / +100°C
- Temperature Range: - 40°C / +85°C

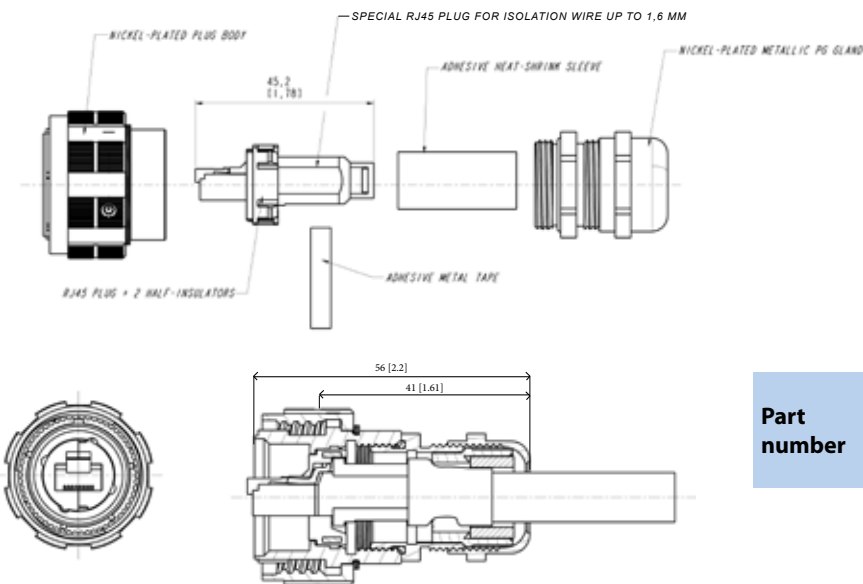

Part number	Plating	P/N
	Nickel	35660
	Olive drab cadmium	35660G



RJ45/M12 adaptor

Adaptor to switch from an Ethernet network based on RJ45 to a network under M12 D coding.



Part number : 35655

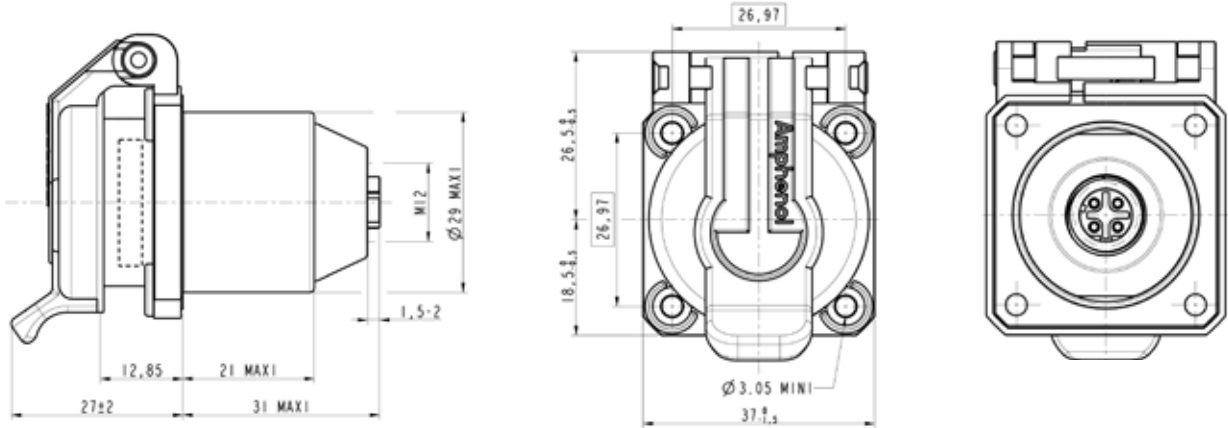

M12-D	RJ45 contact position
1	1
2	3
3	2
4	6

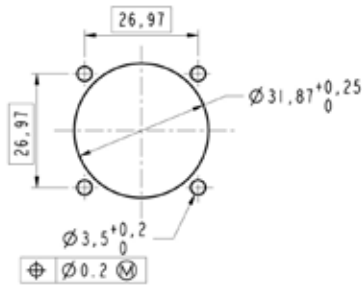

NEW

Special RJ45 adaptor

For Military & Commercial Aeronautics

Adaptor RJ45 only

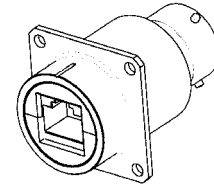
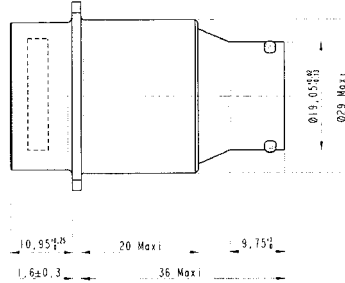

Part number	Coding	
	35629	N
35632	Y	

Adaptor RJ45 + Self Closing Cap

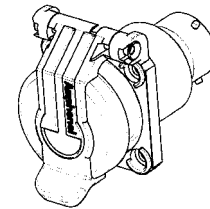
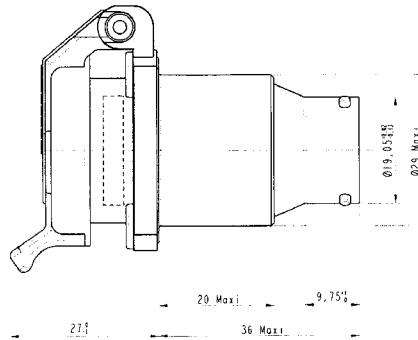

Part number	Coding	
	35630	N
35631	Y	

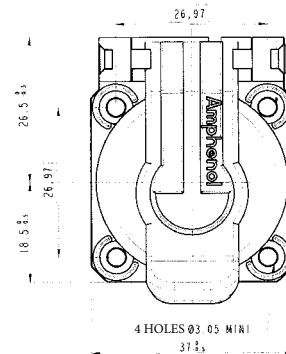
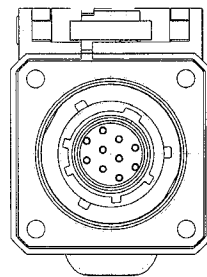

For all options:

Panel Drilling

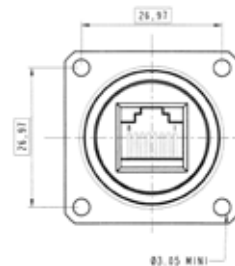
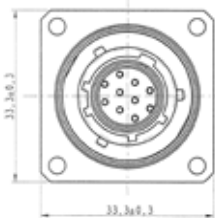
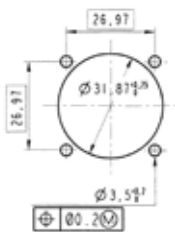

Coding N

12-10 Male contact
EN3155

Coding Y

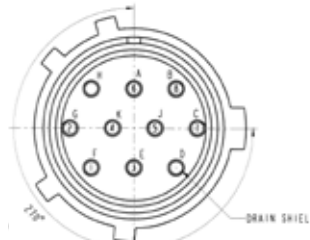
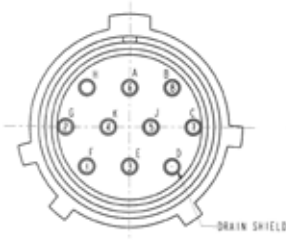

CAT 5E CABLE

High Reliability Cat 5e Ethernet Cable & Cordsets



Applications

- Robotics
- Motion Control
- Railways
- CNC Machines
- Battlefield communication
- Industrial Process Control

General Construction

A 4 pair, 24 AWG, 100 Ohm SFTP round patch cable, designed to the ISO / IEC 11801 Category 5e requirements (cat 5e on 76m).

The cable contains 4 twisted pairs, cabled, double shielded with kevlar reinforcement strands, jacketed in black UV resistant Polyurethane HFFR.

Designed for fixed or portable applications in harsh environments.

HFFR: Halogen Free Flame Retardant

Jacket Compound Specification:

- Halogen Free Flame Retardant Polyether-based Polyurethane
- Excellent hydrolysis resistance
- High microbial resistance
- Glossy finish
- UV resistant
- High flexibility

Datas for the cable alone only (without RJ45 plug)

Physical characteristics

CONDUCTORS	24 AWG (0,25 mm ²) tinned copper, 7x0.20 mm
INSULATION	Color coded 568-B, Linear Low Density Polyethylene, Nom. Dia. 0,039" (1mm)
ASSEMBLY	Pairs cabled with Kevlar strength members and separation tape wrapped
SHIELDS	Inner: Aluminium mylar 100% coverage Outer: Tinned copper braid 80% coverage
JACKET	Black, special PUR compound
WEIGHT	40 lbs / mft (59 kg/km)
OUTSIDE DIAM.	0.28" (7.1 mm) nom.
MIN BEND RADIUS (During installation)	67.5mm (9x O. D.)
MIN BEND RADIUS (During operation)	37.5mm (5 x O.D.)
MIN FLEXES TO FAILURE	Passes IEC 61156-6 requirements
TEMPERATURE	Plus 85°C, minus 40°C

Cordsets with a RJ45 plug overmolded on each end

Length (m/ft)	Part Number
0,76 m / 2,5 ft	RJF SFTP 5E 0076
1,00 m / 3.28 ft	RJF SFTP 5E 0100
1,52 m / 5 ft	RJF SFTP 5E 0152
3,05 m / 10 ft	RJF SFTP 5E 0305
4,57 m / 15 ft	RJF SFTP 5E 0457
5,00 m / 16.4 ft	RJF SFTP 5E 0500
6,00 m / 19.68 ft	RJF SFTP 5E 0600
6,24 m / 20.46 ft	RJF SFTP 5E 0624
7,62 m / 25 ft	RJF SFTP 5E 0762
8,00 m / 26.24 ft	RJF SFTP 5E 0800
10,00 m / 32.78 ft	RJF SFTP 5E 1000
14,00 m / 45.92 ft	RJF SFTP 5E 1400
15,25 m / 50 ft	RJF SFTP 5E 1525
22,87 m / 75 ft	RJF SFTP 5E 2287
30,5 m / 100 ft	RJF SFTP 5E 3050
45,75 m / 150 ft	RJF SFTP 5E 4575
50,00 m / 164 ft	RJF SFTP 5E 5000
61,00 m / 200.08 ft	RJF SFTP 5E 6100

Electrical characteristics

DC Resistance	96 Ohms/Km @ 20°C
Impedance	100 +/- 15 Ohms 1-100 MHz
Attenuation	
772 KHz	2.70 db/100m nom.
1 MHz	3.15 db/100m nom.
4 MHz	6.45 db/100m nom.
10 MHz	9.90 db/100m nom.
16 MHz	12.3 db/100m nom.
20 MHz	13.8 db/100m nom.
31.25 MHz	17.7 db/100m nom.
62.5 MHz	25.6 db/100m nom.
100 MHz	33 db/100m nom.
N.E.X.T. (Near-End Crosstalk Loss)	
772 KHz	64 db min.
1 MHz	62 db min.
4 MHz	53 db min.
10 MHz	47 db min.
16 MHz	44 db min.
20 MHz	42 db min.
31.25 MHz	40 db min.
62.5 MHz	35 db min.
100 MHz	32 db min.
Capacitance	46pF/m nom. @ 1KHz
LCL	43 dB min. @ 64 KHz
Capacitance Unbalance	3.4 pF/m max. @ 1KHz (wire to ground)
Insulation Resistance	150 M Ohm min.
Voltage Rating	230 VMS
Dielectric Strength	VAC/1 min - 700 V/Min
Propagation Delay (100 MHz)	5.2 ns/m max. @ 100 MHz
Delay Skew	20 ns/100m max. @ 1-100 MHz
Resistance Unbalance	3% max. @ 20°C
Structural Return Loss (100 MHz)	23db/100m min. @ 1-20 MHz
Spark test (tested during production)	3 KV
Velocity of propagation	67% nom.

Reel of cable (without RJ45 plug on ends)

Length (m / ft)	Part Number
100 m / ~328 ft	190-038045-00
300 m / ~984 ft	190-038045-01

Rugged Ethernet Solutions



Cable assemblies

Table of contents

 RJ45/M12: Ethernet Railway cable solution	42
 JUMPER Railway intercoach	43



RJ45/M12: Ethernet Railway cable solution



Part number: **Kit 36516** - Length 7 m [22.96 ft]

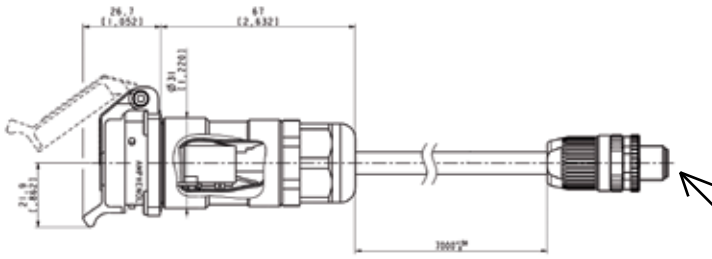

Part number: **Kit 36520** - Length 1 m [3.28 ft]

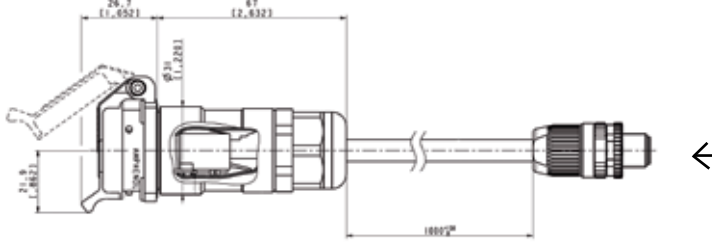

M12 D Coding

Part number: **Kit 36530** - Length 4 m [13.12 ft]

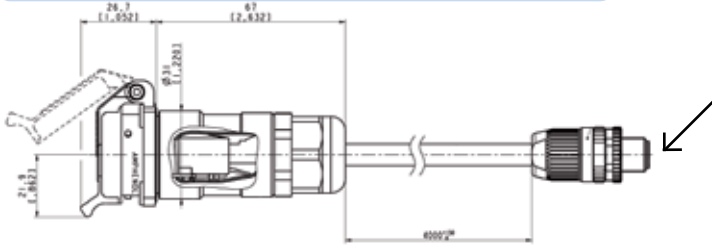

For all options:

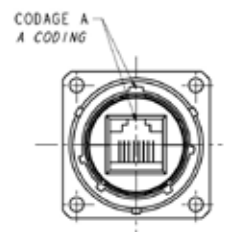
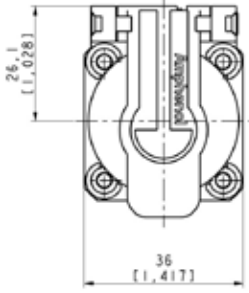
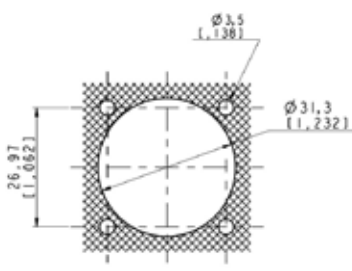



JUMPER Railway Intercoach

Derived from RJFTV Series

Note: for technical characteristics, please refer to RJFTV page 24.

Kit 40426 includes:

- 2 RJF TV plugs with EMI backshell assembled (coding A)
- 1 RJF SFTP cable cat 5E high reliability
- 1 conduit PCST-17B
- 2 PMAFIX straight, PG metal thread



Part number	L ⁺¹⁰⁰ ₀	P/N
	2465	Kit 40426 Rep 101
3010	Kit 40426 Rep 102	

For any other lenght, please consult us: contact@rjfield.com

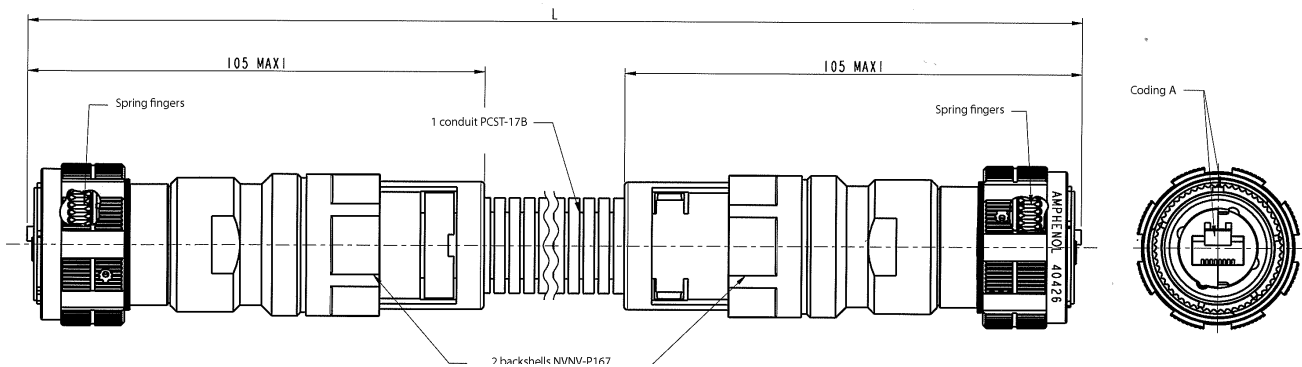

Rugged Ethernet Solutions



Rugged electronics

Table of contents

Industrial Ethernet Switch for harsh environment

RJSPC: Unmanaged or Ring Industrial Ethernet Switch - 5 Fast ports 46

Military Ethernet Switch for harsh environment with industrial EMI compliancy

RJSML-8US1 and RJSML-8UG1: Unmanaged Military Ethernet Switch, Fast or Gigabit 50
 RJSML-MG7F3G : Managed Military Ethernet Switch - 7 Fast ports + 3 Gigabit ports 54



Military Ethernet Switch for harsh environment, fully MIL-STD compliant

RES-SCE-AC-8US: Unmanaged Miniature Portable Ethernet Switch - 8 Fast ports 58
 RESMLAC-8US: Unmanaged Military Ethernet Switch, MIL-DTL-38999 connectors - 8 Fast ports 60
 RJSMLAC-8MG: Managed Military Ethernet Switch, RJFTV connectors - 8 Gigabit ports 62
 RESMLAC-8MG: Managed Military Ethernet Switch, MIL-DTL-38999 connectors - 8 Gigabit ports 64
 RESMLAC-28MG: Managed Military Ethernet Switch - 24 Gigabit + 4 combo 10G ports 66



Military Ethernet Media Converter for harsh environment, fully MIL-STD compliant

RES-GMC: Unmanaged Military Ethernet Media Converter - 2 or 4 Gigabit ports 69

RJSPC

Unmanaged or Ring Industrial Ethernet Switch - 5 Fast ports

Industrial ethernet switch for harsh environment

Rugged & Waterproof Switch

Amphenol offers a small size 5 ports waterproof Ethernet Switch that can withstand a variety of extreme conditions - low & high temperatures, shocks & vibrations, dust particles or even liquid immersion. This is an easy way to make the Ethernet networks of your manufacturing site, automation or control units deterministic.

Amphenol IP68 Industrial Ring Switch

Amphenol IP68 Ring Ethernet switch is a combination of very fast, fault-tolerant network redundancy Sixnet technology and IP68 sealed & rugged packaging, specifically designed for the harshest environments.

Rings self-configure and just run, without any complex configuration.

The switch board is sealed within a waterproof IP68 polyester enclosure suitable for highly corrosive environments.

The polyester material is glass fiber reinforced. This makes it very rugged against shocks and vibration.

The I/O interfaces are waterproof & rugged RJ45 connectors from the RJ FIELD plastic circular series.

Industrial Applications

- Factory Automation
- Robotics
- Process Control
- Transportation Systems
- Data Acquisition & Transmission



Key Features

- Ring Switch Networking Features (managed features available!)
 - Real-Time Ring for ultra-fast fault-tolerant loops
 - Recovery time of 30 ms + 5 ms per hop!
 - Modbus monitoring over Ethernet
 - Ideal for deterministic systems and PLCs
 - Real-time traffic prioritization (QoS and CoS)
 - Assure delivery of real-time data
 - Improve network utilization
 - User settable priority assignments
 - Advanced switch features
 - User configurable port settings
 - Port mirroring for traffic diagnostics
 - Pre-configurable for Plug-And-Play simplicity

Note: for ATEX version, see page 112.

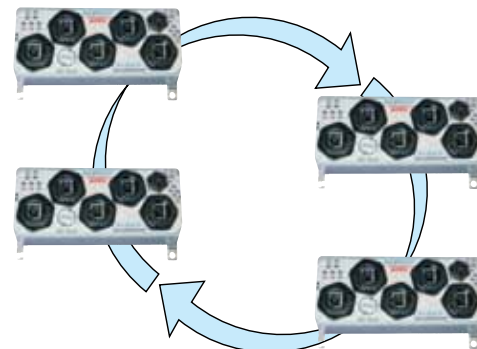

- 1 LEDs indicating activity, link status, datarate (10/100 Mbps)
- 2 LED indicating ring status
- 3 5 rugged IP68 RJ Field Ethernet ports
- 4 Real-time ring feature
- 5 IP68 polyester enclosure reinforced with glass fiber
- 6 OK power & ring status
- 7 LEDs indicating power
- 8 Redundant power inputs
- 9 OK contact output

IP68 UNMANAGED & RING SWITCH FEATURES

IEEE Ethernet Standards

IEEE 802.3	10 Mbps Ethernet
IEEE 802.3u	100 Mbps Fast Ethernet
IEEE 802.3x	Full-Duplex with Flow Control
IEEE 802.1p standard	QoS/CoS - Quality/Class of Service for Ring model only

Regulatory Approvals

EMI emissions	EN55022, FCC part 15, ICES-003
EMC immunity	IEC61326-1, IEEE C37.90
Shocks	IEC60068-2-27
Vibrations	IEC60068-2-6
Free Fall	IEC60068-2-32

Ethernet features

Ports	5 Shielded RJ45 ports 10/100BaseTX
Ethernet switch type	Intelligent store & forward
Full / Half Duplex	Configurable
RJ45 speed	10 or 100 Mbps auto-negotiation
RJ45 MDI/MDIX	Auto-crossover connection
RJ45 TD and RD polarity	Auto-polarity
Typical latency	16 us + frame time @ 10 Mbps (varies on load and settings) 5 us + frame time @ 100 Mbps
MAC addresses supported	2048
Memory bandwidth	3.2 Gbps
Ethernet isolation	1500 Vrms 1 minute
Ring features (for Ring model only)	Link loss recovery time: 30 ms plus 5 ms per hop Maximum switches in ring: 50+ Dual Ring support

Power Supply

Input power (typical)	ES: 2,4 W ; RS: 2,7 W
Redundant inputs	10-30 VDC; 10-50 VDC for EP models

Status Reporting (for Ring model only)

"OK" contact output	Output current: 0.5 A max
"OK" contact State	OFF when a fail occurs ON when power and switching is OK

Environmental

Operating Temperature	- 40°C to +75°C
Storage Temperature	- 40°C to +85°C

Weight	0.54 kg
--------	---------

Real-Time Ring Switches

Amphenol Real-Time Ring switches combines the Plug&Play simplicity of an unmanaged switch with high performances of Sixnet Ring managed switches.

- Real-Time fault-tolerant Ring
Recovery time of 30 ms + 5 ms per hop!
- Real-Time traffic prioritization (QoS & CoS)
Assure delivery of real-time data
- Available Managed features
User configurable port settings
Port mirroring for traffic diagnostics
Pre-configurable for Plug & Play simplicity

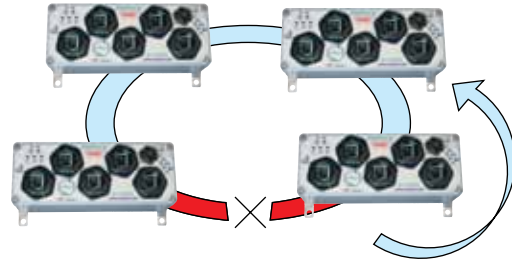

The use of such switches provides a fast network and avoids faults. When a break occurs, the switch instantly transfers data to new path. The link loss recovery is 30 ms plus 5 ms times the number of Ring switches in the ring. For example, 10 ring switches will recover in less than 80 ms. Rings can be pre-configured to "just run". They don't need an assigned IP address. But if you like, you can fine tune the performance of the ring by using a simple Windows wizard (which is free).

Ring networks can be divided into multiple "sub-rings" which enhance reliability and recovery speed through small ring paths.

The prioritization of messages assures delivery of real-time data. Some applications need to force no-real-time data (such as video information) to lower priority and force critical real-time data at higher priority. Network utilization is improved.

This combination of Ethernet technology associated with rugged and sealed protective enclosure is the ideal solution to deliver deterministic performance to your industrial systems even in the harshest environment!

Dimensions (mm/inch)

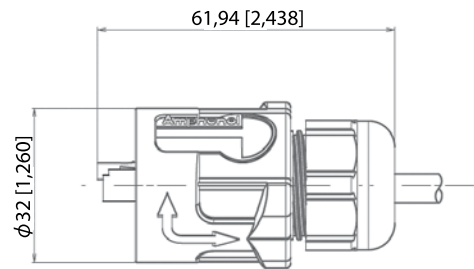
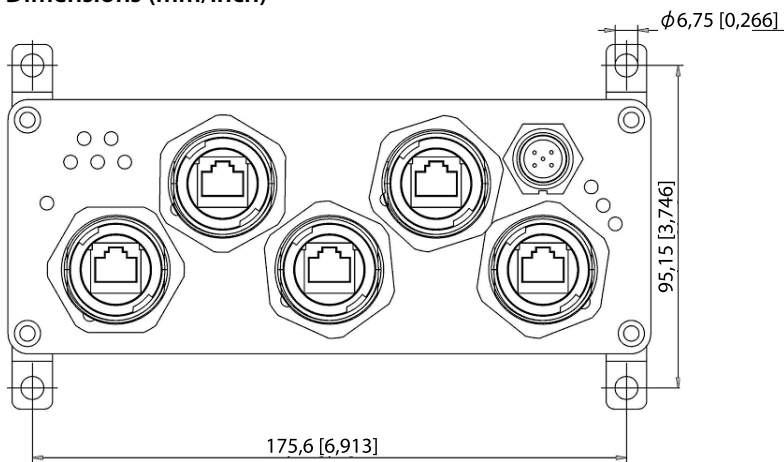

Accessory: Plugs for RJ45 ports

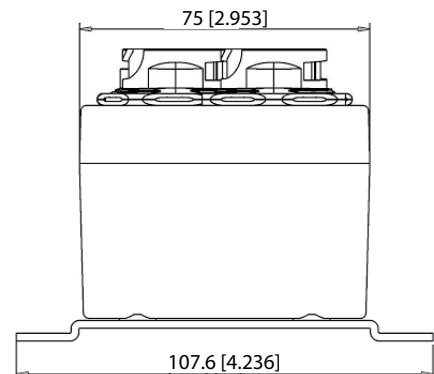
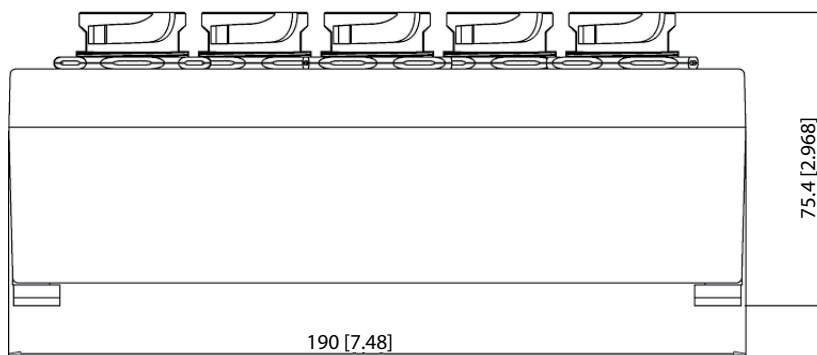

Part Number code

Series	RJS-PC	5ES	1
IP68 RJ-Switch, with polyester body			
Type of Electronics			
5RS:	5 ports 10/100 Mbps, Ring switch		
5ES:	5 ports 10/100 Mbps, Unmanaged switch		
Connectors			
1:	RJ45 ports, 10/100BaseT(X)		
1CAPS:	Caps are attached on both power and data receptacles		
Military Rated Protection			
Blank:	Industrial protection (standard order)		
EP:	Extended power protection exceeds MIL-STD-1275 (special order)		

Example: IP68 Ethernet Ring switch, 5 ports 10/ 100 Mbps, with caps attached on the receptacles: RJS-PC-5RS-1CAPS

Note The Ring model is pre-set for 1 ring enabled on the ports 4 and 5.
You may change the configuration by using the free windows configuration tool.
Simply choose the desired pair of ports for your new enabled ring.

FREE WINDOWS CONFIGURATION TOOL
Download it at www.rjswitch.com

Accessories



■ P/N: **RJF PCS PWR**
Plug for power port
Sealing protection: IP68



■ P/N: **RJF RB 6**
Plug for RJ45 ports
Sealing protection: IP68

RJSML-8US1 & RJSML-8UG1

Unmanaged Military Ethernet Switch - Fast or Gigabit

Military ethernet switch for harsh environment with industrial EMI compliancy

Sealed, Rugged & Unmanaged Switch

Amphenol offers an unmanaged Ethernet Switch with 8 gigabit ports RJSML-8UG1.

The switch can withstand a variety of extreme conditions. Whatever the situation - high temperatures, extreme shocks & vibrations, dust particles or even liquid immersion- there is a solution available.

The switch electronics are sealed within a waterproof IP68 metallic enclosure.

The conductive cadmium plating is suitable for most demanding EMI-RFI environments. Black paint is also offered when RoHS is required (other colors available).

The I/O interface includes redundant power inputs as well as waterproof rugged RJ45 connectors from the RJFTV FIELD threaded product series based on MIL-DTL-38999 (Series III) metallic shell size 19. This serie enables the transformation without tooling of any standard RJ45 cordset into a robust and waterproof connection system.

Military Applications

- Battlefield communication C4ISR
- Rugged Networks
- Mobile communications
- Avionic & Shipboard systems



Key Features

- **Rugged environmental feature**
 - Rugged metal packaging with cadmium or paint protection
 - Mil-DTL-38999 III connectors for both power and Ethernet ports
 - IP65/IP68 rated when mated
 - Power filtering and protection (-704 option)
 - MIL-STD-461E (CE03) 600V spike suppressor
 - MIL-STD-704A
 - MIL-STD-1275A
 - RT CA/DO-160B
 - MIL-STD-810F shocks
 - RTCA/DO-160C Vibrations
 - Full-Duplex operation with flow control (no collisions!)
 - MIL STD 810F Altitude 50,000 ft (15,000 m)
 - Auto-detecting, auto-crossover and auto-polarity
 - Broadcast storm protection
- **Models 8US1**
 - 8 ports 10/100-BaseT(X)
 - Wide operating temperature range of -40°C to 70°C
- **Models 8UG1**
 - 8 ports 10/100/1000-BaseT(X)
 - Wide operating temperature range of -10°C to 60°C
 - Supports Jumbo frame transmission up to 9kbytes

IEEE Ethernet Standards

Models	Features	802.3/u	802.3x	802.3ab
RJS XX 8US1 XX	Unmanaged - Fast	●	●	X
RJS XX 8UG1 XX	Unmanaged - Gigabit	●	●	●

IEEE 802.3/u	10 Mbps & 100 Mbps Fast Ethernet
IEEE 802.3x	Full-Duplex with Flow Control
IEEE 802.3ab	1000 Mbps Gigabit Ethernet

Ethernet features

RJ45 Ports	8 shielded RJ45 ports 10/100 BaseT(X) or 1000 Base T(X)
Connectors for RJ45 ports	RJFTV: jam nut receptacle based on MIL-DTL-38999 III Olive drab cadmium or Nickel plated
RJ45 speed	10, 100 or 1000 Mbps auto -negotiation
Full / Half Duplex	Automatic
MDI/MDIX	Auto-crossover

Environmental specifications

Safety	UL 60950-1, CAN/CSA-C22.2 No.60950
EMI emissions	U.S.A.: FCC Part 15 CISPR 22 U.E. EN55011, EN61000-6-4, EN55022 Class A, EN61000-3-2/3, EN55024, IEC61000-4-2/3/4/5/6/8, EN61000-6-2
Shocks	MIL-STD-810F: 40g, 11 ms, 18 saw tooth shocks
Vibrations	RTCA/DO-160C Sinusoidal vibrations 5-55 Hz: 0.01 inch; 55-500 Hz: 1.5 g
Altitude	MIL-STD-810F: 50.000 ft - 15.000 m
Temperature	Operating Models 8UG1: -10°C to +60°C Models 8US1: -40°C to +70°C Storage all models: -40°C to +85°C

Weight	approx 2.8 kg
---------------	---------------

Power Supply

Input voltage	8US1 & 8UG1: 12-48 VDC, redundant power input (P1 and P2) 8US1-704 & 8UG1-704: 12-33 VDC, single power input (P1 only) 8US1-PSM & 8UG1-PSM: 85-264 VAC single power input
Input power	5 W max
Connectors for power	MIL-DTL-38999 III jam nut receptacle, olive drab cadmium or nickel plated 1 connector TVx07xx0935P: 6 cts # 22D (wire 0.38 mm ² maxi)
"OK" contact output	Sourcing power ; Maximum current: 1 A @ 24VDC Not available for -704 and -PSM options

Additional power protection for models MG7F3G-704 (option-704)

MIL-STD-461E	CE102 Conducted emission
DEF-STAN-59-41	DCE01/DCE02
DEF-STAN-61-5	Pt 6
MIL-STD-704A	600V input transient, applied for 10us
MIL-STD-1275A	Spikes: +/- 250 V for 100us Surges: 100 V for 50 ms at 0.5 mohm Ripple: 14VAC pk-pk

Description

- 1 IP68 Aluminium enclosure with Cadmium Conductive Plating or Black paint (RoHS)
- 2 Redundant Power Inputs
- 3 Balance pressure vent
- 4 8 Rugged IP68 RJF TV Ethernet Ports
- 5 Fixture for vertical mounting

Optional caps available

IMPORTANT NOTE

This model has no LED indicator.



Description (in mm)

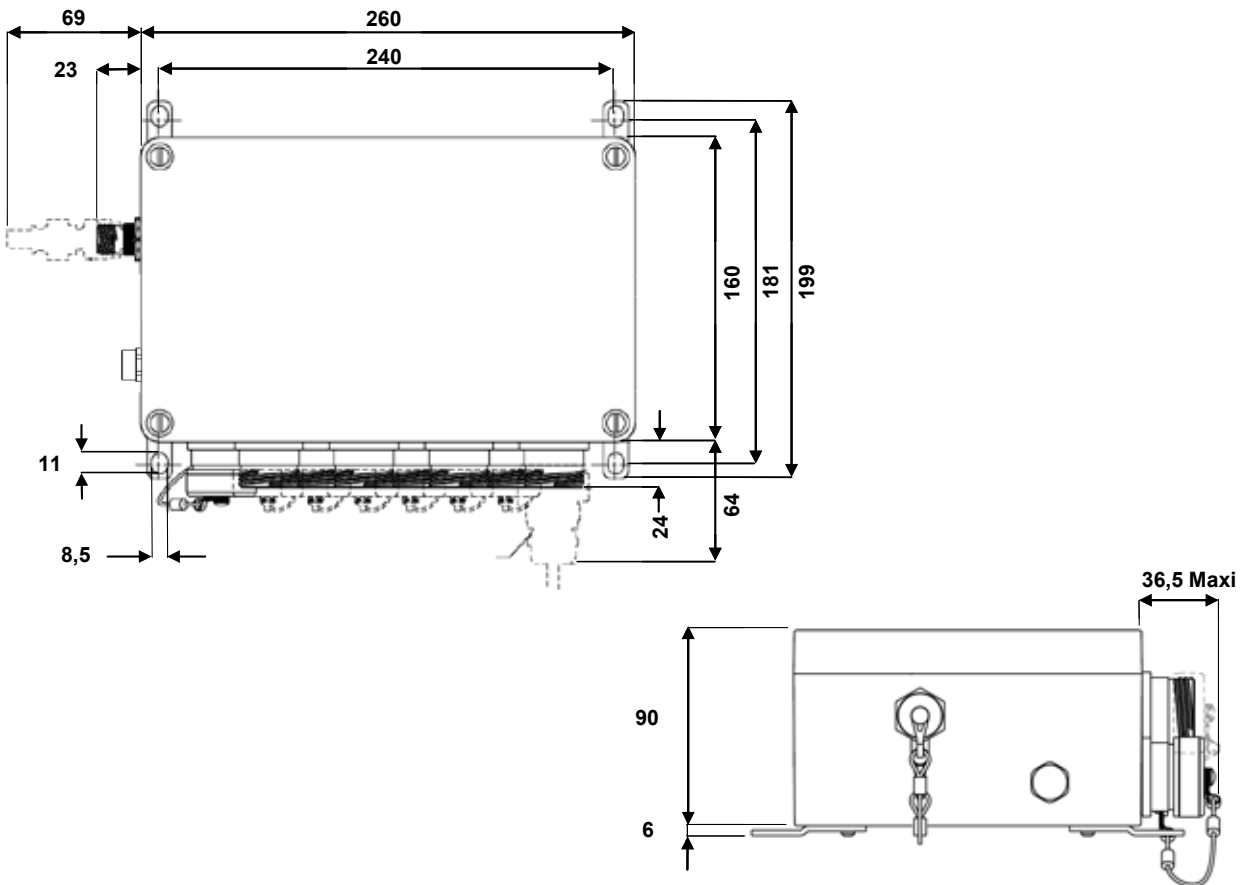

Pin-out for the power connector

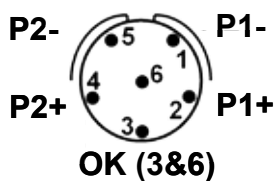

8US1 & 8UG1
P1 and/or P2: 12-48 VDC



8US1-704 & 8UG1-704
P1: 12-33VDC
3, 4, 5, 6: not connected



8US1-PSM & 8UG1-PSM
L: 85-264 VAC
3, 4, 5, 6: not connected

Part Number code

Series	RJS	ML	8US1	-	-	-
Type of Enclosure						
ML	MIL-DTL-38999 (series III) Receptacles, OD Cadmium Plating					
BKN	RAL 9005 (Jet black) Paint on Aluminium box, Nickel plated 38999 (series III) Receptacles, ROHS compliant					
Type of Electronics						
8US1	Unmanaged 8 ports 10/100 Base T(X)					
8UG1	Unmanaged 8 ports 10/100/1000 Base T(X)					
Optional: Transient suppression module; 600V spike suppressor						
(Blank)	No transient suppression module					
704	Switch equipped with additional transient suppression module					
Optional: AC power supply						
(Blank)	DC powered					
PSM	Switch powered with 85-264 VAC instead of DC power					
Optional: Caps for receptacles fixed with cord directly to the receptacle						
(Blank)	No caps included. The Ethernet ports are still sealed but the contacts are not protected					
CAPS	Attached caps for both power and data included					

Example: RJS ML 8UG1 704 CAPS Unmanaged switch in an aluminum enclosure with olive drab green conductive cadmium plating, 8 gigabit ports, RJFTV threaded coupling receptacles, additional transient suppression module, caps are added to the switch

Remark: All BKN Ethernet switches and nickel plated accessories are RoHs compliant.
 -704- and -PSM- options can not be selected together.
 With the -704- option, a filter module is included inside the switch allowing to meet MIL-STD-461 and other aircraft standards.
 With the -CAPS- option, all the receptacles come pre-equipped with a cap.

Accessories

Plugs for Ethernet ports
 RJF TV 6 M G: cadmium OD plating
 RJF TV 6 M N: nickel plating
 Based on MIL-DTL-38999
 No tool required !!!



Caps for Ethernet ports
 RJSML C7G: cadmium OD plating
 RJSML C7N: Nickel plating
 A simple screwdriver is needed!



Plugs for I/O ports:
 MIL-DTL-38999,
 cadmium plated, crimp contacts
 Two plugs (6 cts # 22D)
 TV 06 RW 0935 S: cadmium OD plating
 TV S06 RF 0935 S: nickel plating



Backshells for I/O plugs
 We suggest to use MIL-DTL-38999 III backshells.
 Consult the dedicated catalog (E118) for details.
 Examples:
 TVNSA 09 014 : shielding backshell, cadmium OD plating
 TVNSA 09 023: shielding backshell, nickel plating
 + 804221 straight heat shrink for sealing



Example: RJS ML MG7F3G 704 CAPS with an RJSML MG7F3G 704 CAPS switch, we suggest to use hereafter accessories:
 RJF TV 6 M G (up to 10) for Ethernet ports
 TV 06 RW 0935 S + TVNSA 09 014 + 804221 for power ports

RJSML-MG7F3G

Managed Military Ethernet Switch - 7 Fast ports + 3 Gigabit ports

Military ethernet switch for harsh environment with industrial EMI compliancy

Sealed, Rugged & Managed Switch

Amphenol offers a 10 ports managed Ethernet Switch RJSML-MG-7F3G.

Note: This model replaces the RJSML-9MG1 and the RJSML-9RG1.

The switch can withstand a variety of extreme conditions: whatever the situation - high temperatures, extreme shocks and vibrations, dust particles or even liquid immersion there is a solution available.

The switch electronics are sealed within a waterproof IP68 metallic enclosure.

The conductive cadmium plating is suitable for most demanding EMI-RFI environments. Black paint is also offered when RoHs is required (others colors available).

The I/O interface includes redundant power inputs as well as waterproof rugged RJ45 connectors from the RJF TV FIELD threaded product series based on MIL-DTL-38999 (Series III) metallic shell size 19.

This serie enables the transformation without tooling of any standard RJ45 cordset into a robust and waterproof connection system.

Military Applications

- Data Acquisition & Transmission
- Battlefield communication C4ISR
- Rugged Networks
- Mobile communications
- Test Equipment
- Avionic & Shipboard systems

Key Features

- **Rugged environmental feature**
 - Rugged metal packaging with cadmium or paint protection
 - Mil-DTL-38999 III connectors for both power and Ethernet ports
 - IP65/IP68 rated when mated
 - Power filtering and protection (-704 option)
 - MIL-STD-461E (CE03) 600V spike suppressior
 - MIL-STD-704A
 - MIL-STD-1275A
 - RTCA/DO-160B
 - MIL-STD-810F shocks
 - RTCA/DO- 160C Vibrations
 - Wide operating temperature range of -40°C to 70°C
 - MIL-STD-810F Altitude 50,000 ft 15,000 m
- **Ethernet features**
 - 3 ports 10/100/1000-BaseT(X) + 7 ports 10/100-BaseT(X)
 - Full-Duplex operation with flow control (no collisions!)
 - Auto-detecting, auto-crossover and auto-polarity
 - MIL-STD-810F shocks
 - RSTP for redundant rings
 - QoS and CoS priority queuing
 - SNMPv3 authentication and encryption
 - IGMP for multicast filtering
 - VLAN for traffic segregation
 - And much more !



IEEE Ethernet Standards

Models	Features	802.3/u	802.3x	802.3z	802.1p	802.1D	802.1w	802.1Q
RJS XX MG 7F3G XX	Managed - Gigabit	●	●	●	●	●	●	●
IEEE 802.3/u	10 Mbps & 100 Mbps Fast Ethernet			IEEE 802.1p	Priority queuing - QoS, CoS, ToS/DS			
IEEE 802.3x	Full-Duplex with Flow Control			IEEE 802.1D/w	Rapid Spanning Tree for redundant rings			
IEEE 802.3ab	1000 Mbps Gigabit Ethernet			IEEE 802.1Q	VLAN for traffic segregation			

Ethernet features

RJ45 Ports	10 shields RJ45 ports 10/100 BaseT(X) or 1000 Base T(X)
Connectors for RJ45 ports	RJFTV: jam nut receptacle based on MIL-DTL-38999 III Olive drab cadmium or Nickel plated
RJ45 speed	10 or 100 Mbps auto -negotiation
Typical latency	16 us + frame time @ 10 Mbps (varies on load and settings) 5 us + frame time @ 100 Mbps
Full / Half Duplex	Automatic or Configurable
RJ45 MDI/MDIX	Auto-crossover
RJ45 TD and RD polarity	Auto-polarity
MAC addresses supported	8192
Memory bandwidth	32 Gbps (gigabit) ; 3.2 Gbps for all other models
Ethernet isolation	1500 Vrms 1 minute
Ring features	Link loss recovery time: 30 ms plus 5 ms per hop
<i>(for Ring model only)</i>	Maximum switches in ring: 50+ Dual Ring support

Environmental specifications

EMI emissions	EN55022 class A, FCC part 15, IC ES-003
EMC immunity	IEC61326-1, IEEE C37.90
Shocks	MIL-STD-810F: 40g, 11ms, 18 saw tooth shocks
Vibrations	RTCA/DO-160C Sinusoidal vibrations 5-55 Hz: 0.01 inch ; 55-500 Hz: 1.5 g
Altitude	MIL-STD-810F: 50.000 ft - 15.000 m
Temperature	Operating -40°C to +70°C Storage -40°C to +85°C

Weight approx 2.8 kg

Power Supply

Input voltage	MG7F3G: 10-30 VDC, redundant power input (P1 and P2) MG7F3G-704: 10-30 VDC, single power input (P1 only) MG7F3G-PSM: single power input AC or DC <ul style="list-style-type: none"> - AC voltage: 85-264 VAC/Frequency 47-63 Hz - DC voltage: 120-370 VDC
Input power	5 W typical (all ports active)
Connectors for power	MIL-DTL-38999 III jam nut receptacle, olive drab cadmium or nickel plated 1 connector TVx07xx0935P: 6 cts # 22D (wire 0.4 mm ² maxi)
"OK" contact output	Sourcing power ; Maximum current : 0.5 A MG7F3G: ON if P1 and P2 have power and switch software is running MG7F3G-704: ON when software is running MG7F3G-PSM: ON when software is running; output power: 24VDC

Additional power protection for models MG7F3G-704 (option-704)

MIL-STD-461E	CE102 Conducted emission
DEF-STAN-59-41	DCE01/DCE02
DEF-STAN-61-5	Pt 6
MIL-STD-704A	600V input transient, applied for 10us
MIL-STD-1275A	Spikes: +/- 250 V for 100us Surges: 100 V for 50 ms at 0.5 mohm Ripple: 14VAC pk-pk

Description

- 1 IP68 Aluminium enclosure with Cadmium Conductive Plating or Black paint (RoHS)
- 2 Redundant Power Inputs
- 3 Balance pressure vent
- 4 10 Rugged IP68 RJF TV Ethernet Ports
- 5 Fixture for vertical mounting
- 6 Optional caps available



IMPORTANT NOTE

This model has no LED indicator.
Management is done through a web browser

Description (in mm)

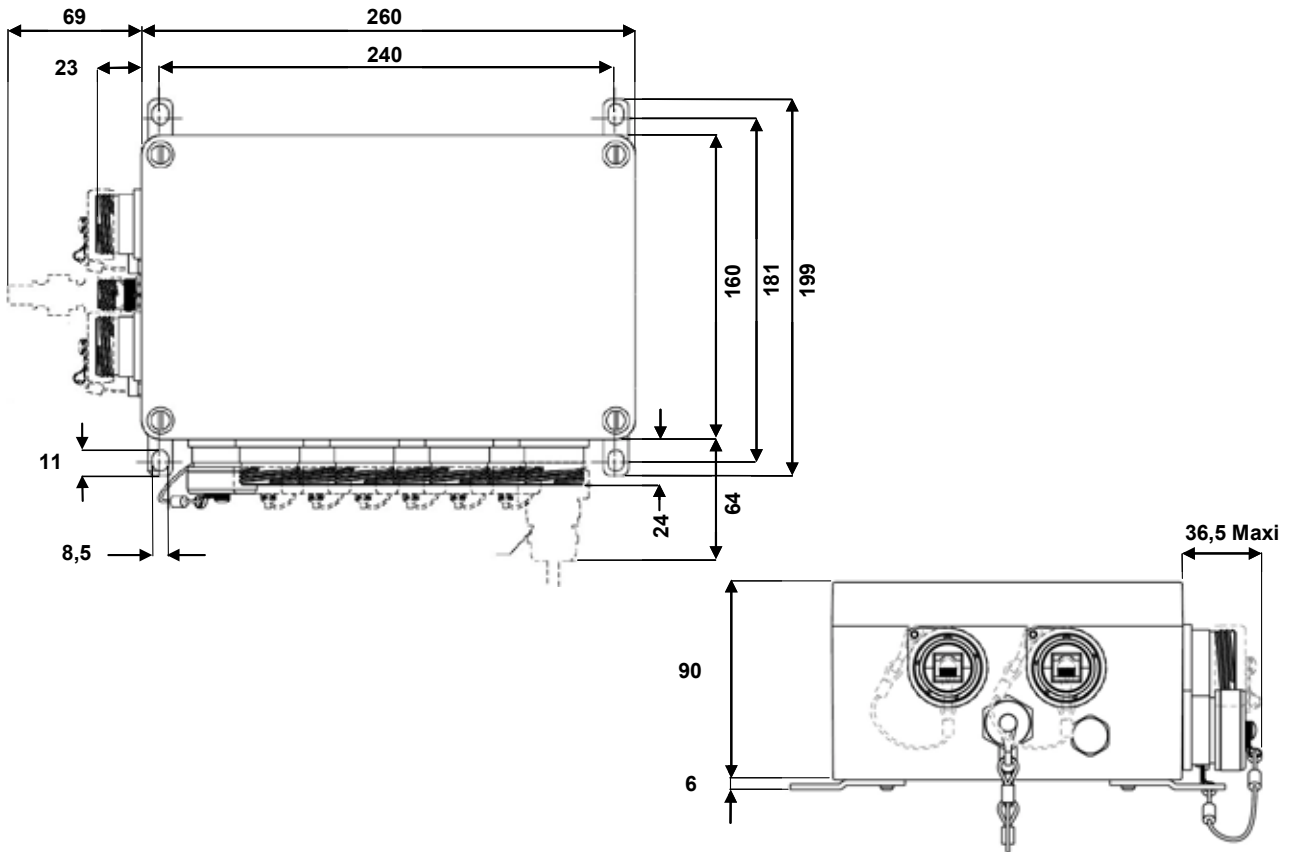

Pin-out for the power connector

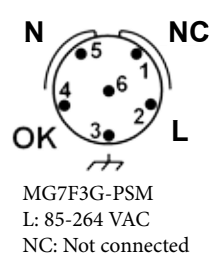
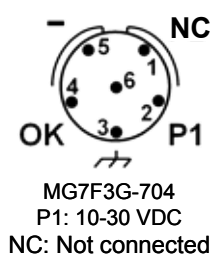
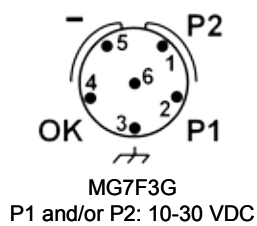

Part Number code

Series	RJS	ML	MG7F3G	-	-	-
Type of Enclosure						
ML	MIL-DTL-38999 (series III) Receptacles, OD Cadmium Plating					
BKN	RAL 9005 (Jet black) Paint on Aluminium box, Nickel plated 38999 (series III) Receptacles, ROHS compliant					
Type of Electronics						
MG7F3G	Managed 6 ports 10/100 Base T(X) + 3 ports 10/100/1000 Base T(X)					
Optional: Transient suppression module; 600V spike suppressor						
(Blank)	No transient suppression module					
704	Switch equipped with additional transient suppression module					
Optional: AC power supply						
(Blank)	DC powered					
PSM	Switch powered with 85-264 VAC instead of DC power					
Optional: Caps for receptacles fixed with cord directly to the receptacle						
(Blank)	No caps included. The Ethernet ports are still sealed but the contacts are not protected					
CAPS	Attached caps for both power and data included					

Example: RJS ML MG7F3G 704 CAPS Managed switch in an aluminium enclosure with olive drab green conductive cadmium plating, 7 ports 10/100 Base T(X) + 3 gigabit ports, RJF TV threaded coupling receptacles, additional transient suppression module, caps are added to the switch.

Remark: All BKN Ethernet switches and nickel plated accessories are RoHs compliant.
704 and PSM options can not be selected together.
With the -704 option, a filter module is included inside the switch allowing to meet MIL-STD-461 and other aircraft standards.
With the -CAPS option, all the receptacles comes pre-equipped with a cap.

Accessories

Plugs for Ethernet ports
RJF TV 6 M G: cadmium OD plating
RJF TV 6 M N: nickel plating
Based on MIL-DTL-38999
No tool required !!!



Caps for Ethernet ports
RJSML C7G: cadmium OD plating
RJSML C7N: Nickel plating
A simple screwdriver is needed!



Plugs for I/O ports:
MIL-DTL-38999,
cadmium plated, crimp contacts
Two plugs (6 cts # 22D)
TV 06 RW 0935 S: cadmium OD plating
TV S06 RF 0935 S: nickel plating



Backshells for I/O plugs
We suggest to use MIL-DTL-38999 III backshells.
Consult the dedicated catalog (E118) for details.
Examples:
TVNSA 09 014 : shielding backshell,
cadmium OD plating
TVNSA 09 023: shielding backshell, nickel plating
+ 804221 straight heat shrink for sealing



Example: RJS ML MG7F3G 704 CAPS With a RJSML MG7F3G 704 CAPS switch, we suggest to use hereafter accessories :
RJF TV 6 M G (up to 10) for Ethernet ports
TV 06 RW 0935S + TVNSA 09 014 + 804221 for power ports

NEW

RES-SCE-AC-8US

Unmanaged Miniature Portable Ethernet Switch - 8 Fast ports

Military ethernet switch for harsh environment - Fully MIL-STD compliant

Amphenol's RES-SCE-AC-8US is a MIL-STD rugged, Unmanaged-military-grade Ethernet switch, offering 8 Fast Ethernet 10/100 Ports. The Portable Rugged Ethernet Switch is intended for Command Post Man Packable.

Developed for mobile portable military and harsh environment applications, the RES-SCE-AC-8US features mechanical packaging enhancements designed for MIL-STD-810F airborne and ground environmental compliance and high reliability. The unit has been especially hardened to improve ingress, impact, and shock/vibration protection, as well as eliminate all moving parts through passive cooling, and interface through sealed MIL-SCE circular connectors.

Leveraging best-in-class switching technology, the RES-SCE-AC-8US serves as a robust solution for providing local area network (LAN) connectivity to IP-enabled computing and net-centric devices. Compact in size, the RES-SCE-AC-8US is particularly useful for expanding port density in space-constrained airborne and ground vehicle environments.

Military applications

- Data Acquisition & Transmission
- Battlefield communication C4ISR
- Rugged Networks
- Mobile communications
- Combat vehicles
- Avionic & Shipboard systems



Key Features

- **Ethernet Ports**
 - 8 x switched 10/100 (Fast Ethernet) ports
- **Networking**
 - Full wire-speed forwarding rate
 - Store-and-forward mechanism
 - Auto MDI-II, MDI-X
 - Auto-negotiation protocol
 - Address look-up
- **Connectors**
 - Power + LAN connector : SCE2-B-76A06-07SN-001
- **Chassis**
 - Low profile rugged aluminium extrusion
 - Conductively cooled w/ custom internal heat-sinks
 - Ingress protection against sand, dust and moisture
 - Anodize Coating, MIL-A-8625, Type II, Class 2
- **Standards**
 - MIL-STD-461E, MIL-STD-810F/G/GM, IP68
- **Voltage operation**
 - 5VDC (USB) INPUT, shared with LAN Port Number 1



Product specifications

Performance

- 128K byte of SRAM for frame buffering
- 2.0 Gbps high-performance memory bandwidth
- LED indication (speed, link/activity) per port - Optional
- Wire-speed reception and transmission
- Integrated address look-up engine
- Automatic address learning

Standards compliance

- IEEE 802.3 10 Mbps 10BASE-T (Ethernet)
- IEEE 802.3u 100BASE-TX 100 Mbps (Fast Ethernet)
- IEEE 802.3x flow control

Power

- Voltage input: 5Vdc nominal - Optional USB sourcing
- Power consumption: 2W typical
- Chassis grounding

Electromagnetic

- MIL-STD-461E electromagnetic compatibility
- CE-102, CS-114, CS-115, CS-116, RE-102, RS-103

Environmental

- MIL-STD-810F/G/GM
- Random vibration (514.5I), Bench handling (516.6VI), High temp (501.5I, II), Low temp (502.5I), Humidity (507.5II), Air pressure (500.5I, II), Blowing rain (506.5I), Immersion (512.5I), Salt atmosphere (509.5I), Blowing dust (510.5I), Loose cargo vibration (514.6II), Wind analysis
- IP68

Physical

- Dimensions: 82.2mm (L) x 61.4 (W) x 26 (H), Not including connectors Dust Caps.
- Weight: 140g - Not including dust caps

Installation

- Portable, flat for mounting to any flat surface.

Cooling

- No moving parts. Passive cooling.

Operating temp

- -35°C to +75°C (-31°F to +167°F) - Cold start-up

Storage temp

- -45°C to +85°C (-49°F to +185°F)

Dimensional Line Drawing

All measurements are in millimeters

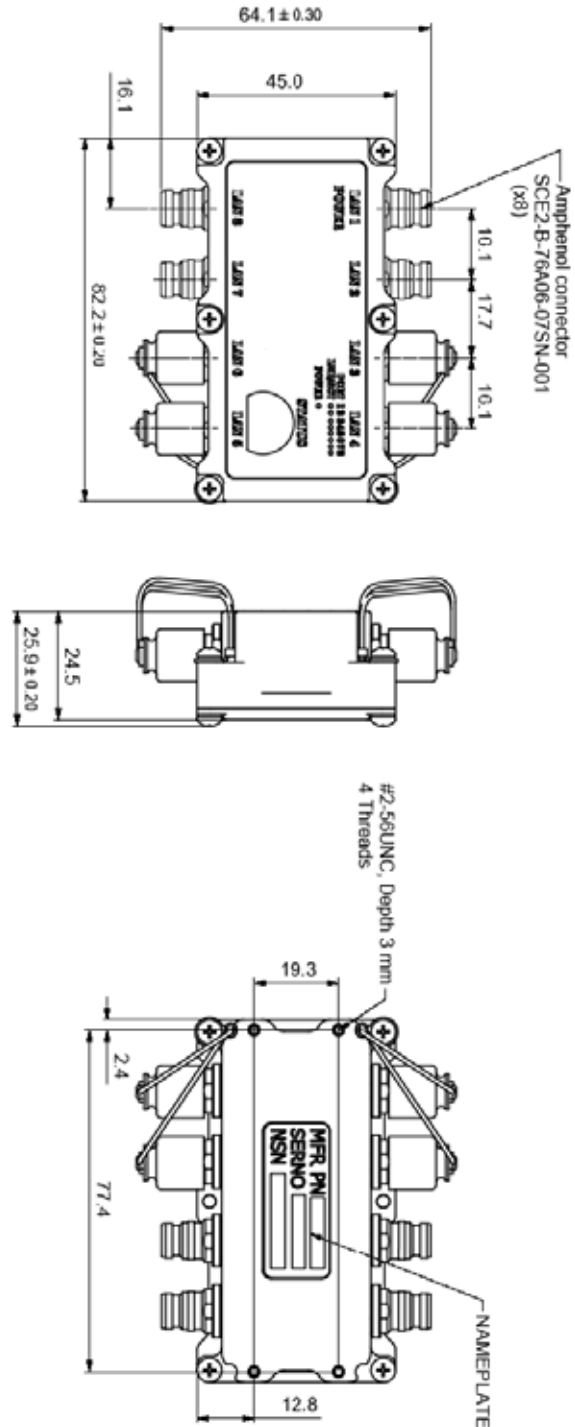

Part number	Description
RES-SCE-AC-8US	<ul style="list-style-type: none"> • RES-SCE-AC-8US • MIL-STD Rugged • 8 x 10/100TX • Unmanaged switch
RES-SCE-CBL-1M50	<ul style="list-style-type: none"> • Starter cable set for MILTECH-308 • MIL-SCE to RJ-45 connectors • 1m50 (5 feet) length (Data or Data+Power)

NEW

RESMLAC-8US

Unmanaged Military Ethernet Switch, MIL-DTL-38999 connectors 8 Fast ports

Military ethernet switch for harsh environment - Fully MIL-STD compliant

Amphenol's RESMLAC-8US is a MIL-STD rugged, Unmanaged-military-grade Ethernet switch, offering 8 Fast Ethernet 10/100 Ports.

Developed for military and harsh environment applications, the RESMLAC features mechanical packaging enhancements designed for MIL-STD-810F airborne and ground environmental compliance and high reliability. The unit has been especially hardened to improve ingress, impact, and shock/vibration protection, as well as eliminate all moving parts through passive cooling, and interface through sealed MIL-D-38999 circular connectors.

Leveraging best-in-class switching technology, the RESMLAC serves as a robust solution for providing local area network (LAN) connectivity to IP-enabled computing and net-centric devices. Compact in size, the RESMLAC is particularly useful for expanding port density in space-constrained airborne and ground vehicle environments.

Military applications

- Data Acquisition & Transmission
- Battlefield communication C4ISR
- Rugged Networks
- Mobile communications
- Combat vehicles
- Avionic & Shipboard systems



Key Features

- **Ethernet Ports**
 - 8 x switched 10/100 (Fast Ethernet) ports
- **Networking**
 - Full wire-speed forwarding rate
 - Store-and-forward mechanism
 - Auto MDI-II, MDI-X
 - Auto-negotiation protocol
 - Address look-up
- **Connectors**
 - MIL-D-38999 (Power & Ethernet signals)
 - Power connector type: D38999/24WA98PA
 - LAN connector type: D38999/24WA35SN
- **Chassis**
 - Low profile rugged aluminium extrusion
 - Conductively cooled w/ custom internal heat-sinks
 - Ingress protection against sand, dust and moisture
 - Anodize Coating, MIL-A-8625, Type II, Class 2
- **Standards**
 - MIL-STD-1275, MIL-STD-704A, MIL-STD-461E, MIL-STD-810F GM, IP67
- **Voltage operation**
 - 24VDC (18VDC ~ 36VDC)

MILITARY RUGGED SWITCH
 MIL-STD-1275
 MIL-STD-704A
 MIL-STD-461E
 MIL-STD-810F/GM
 IP67

Product specifications

Performance

- 128K byte of SRAM for frame buffering
- 2.0 Gbps high-performance memory bandwidth
- 2 LED indication (speed, link/activity) per port
- Wire-speed reception and transmission
- Integrated address look-up engine
- Automatic address learning

Standards compliance

- IEEE 802.3 10 Mbps 10BASE-T (Ethernet)
- IEEE 802.3u 100BASE-TX 100 Mbps (Fast Ethernet)
- IEEE 802.3x flow control

Power

- MIL-STD-1275B & MIL-STD 704A surge and spike protection
- Voltage input: 24Vdc nominal (18-32V)
- Power consumption: 2.8W typical
- Chassis grounding

Electromagnetic

- MIL-STD-461E electromagnetic compatibility
- RE-02, RS-03

Environmental

- MIL-STD-810F, 501.4I, 501.4II, 502.4I, 502.4II, 507.4, 500.4II, 514, 516I, 516VI, 514.5, 512.4
- IP67

Physical

- Dimensions: 269mm(L) x 133(W) x 65(H), including connectors & hardware

Installation

- Set of four 4x4.5 mounting holes on bottom for mounting to any flat surface.

Cooling

- No moving parts. Passive cooling.

Operating temp

- -35°C to +75°C (-31°F to +167°F) - Cold start-up

Storage temp

- -45°C to +85°C (-49°F to +185°F)

Dimensional Line Drawing

All measurements are in millimeters

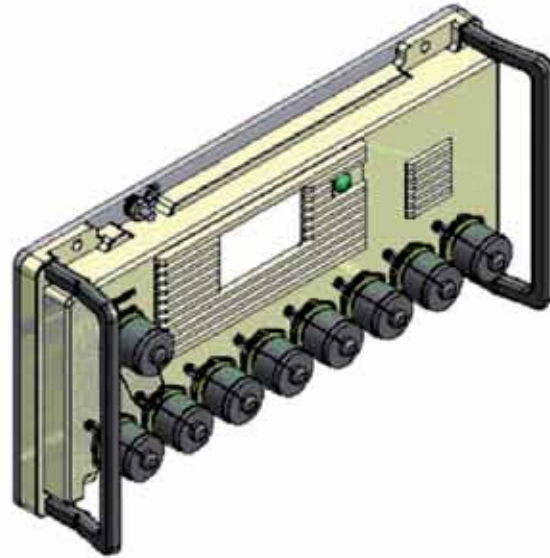
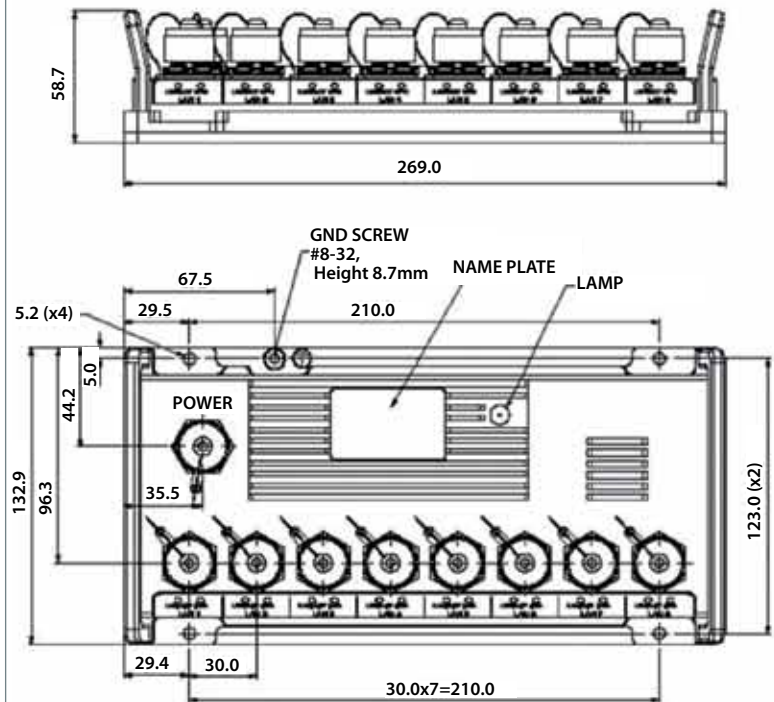

		Description
Part number	RESMLAC 8US CAPS	<ul style="list-style-type: none"> • MIL-STD Rugged • 8 x 10/100TX • Unmanaged switch • with caps
	RESMLAC 8US CBL 1M50	<ul style="list-style-type: none"> • Starter cable set for RESMLAC • MIL-D-38999 to RJ-45 connectors • 1m50 (5 feet) length
	RESMLAC HND	<ul style="list-style-type: none"> • Carrying handles kit for RESMLAC 8US CAPS switch

NEW

RJSMLAC-8MG

Managed Military Ethernet Switch, RJFTV connectors - 8 Gigabit ports

Military ethernet switch for harsh environment - Fully MIL-STD compliant

Amphenol's RJSMLAC 8MG is a MIL-STD Fully managed Military-grade network switch offering 8 triple speed (10/100/1000) ports. Ethernet connectors are RJFTV, using RJField patented system that allows easy and quick assembly of any standard RJ45 cordset without any tool.

Developed for military and harsh environment applications, the RJSMLAC 8MG features mechanical packaging enhancements designed for MIL-STD-810F airborne and ground environmental compliance and high reliability. The unit has been especially hardened to improve ingress, impact, and shock/vibration protection, as well as eliminate all moving parts through passive cooling, and interface through sealed MIL-DTL-38999 circular connectors.

Leveraging best-in-class switching technology, the RJSMLAC 8MG serves as a robust solution for providing local area network (LAN) connectivity to IP-enabled computing and net-centric devices. Compact in size, the RJSMLAC 8MG is particularly useful for expanding port density in space-constrained airborne and ground vehicle environments.

Military Applications

- Data Acquisition & Transmission
- Battlefield communication C4ISR
- Rugged Networks
- Mobile communications
- Combat vehicles
- Avionic & Shipboard systems



Key Features

- **Ethernet ports**
 - Managed 8 x switched 10/100/1000 ports on RJFTV connectors
- **Networking**
 - Spanning tree (802.1d), RSTP (802.1w) and multiple
 - Spanning tree (802.1S) for fast recovery rings
 - Security via Radius Authentication 802.1x, port security, port mirroring
 - Multicasting (IGMP Snooping), GARP, GMRP, and GVRP, Broadcasting and flooding control up to 8K groups.
 - 802.1q tagged based VLAN up to 4K VLAN groups.
 - QoS multi-layer classifier, 802.1p, ToS/DSCP traffic classification. WFQ, Strict Queuing.
 - Bridge support for Q-in-Q.
 - Link aggregation 802.3AD.
 - WEB, CLI, Telnet management.
- **Connectors**
 - Power connector type: MIL-DTL-38999/24WA98PA
 - LAN connector type: RJFTV (coupling mechanism from MIL-DTL-38999)
 - LED indication per port (Speed, Link/Activity)
- **Chassis**
 - Low profile rugged aluminium extrusion
 - Conductively cooled w/custom internal heat-sinks
 - Ingress protection against sand, dust and moisture
 - Anodize Coating, MIL-A-8625, Type II, Class 2
- **Standards**
 - MIL-STD-1275, MIL-STD-704A, MIL-STD-461E,
 - MIL-STD-810F GM, IP68

MILITARY RUGGED SWITCH
 MIL-STD-1275
 MIL-STD-704A
 MIL-STD-461E
 MIL-STD-810F/GM
 IP68

Product specifications

Volage operation

- 24VDC (18VDC ~ 32VDC)

Performance

- 26.8 Mpps wire speed forwarding rate
- 20 Gbps maximum forwarding bandwidth
- 8K MAC address

Standards compliance

- IEEE 802.1x MAC based Authentication
- IEEE 802.1Q Vlan Tagging
- IEEE 802.1P QoS
- IEEE 802.1S Multiple STP
- IEEE 802.1W Rapid STP
- IEEE 802.1AD Link Aggregation
- IEEE 802.1X

Power

- Exceed MIL-STD-1275B Surge and Spike protection
- Voltage input: 24Vdc nominal (18-32V)
- Power consumption: 2.8W typical
- Chassis grounding

Electromagnetic

- MIL-STD-461E Electromagnetic compatibility
- RE-02, RS-03

Environmental : shock/vibration/humidity

- MIL-STD-810F, 501.4I, 501.4II, 502.4I, 502.4II, 507.4, 500.4II, 514, 516I, 516VI, 514.5, 512.4 IP68

Physical

- Dimensions: 287mm(L) x 147(W) x 50(H), including connectors & hardware
- Weight: 1.5 kg

Installation

- Set of four 4.5 mounting holes on bottom for mounting to any flat surface.
- Carrying handles

Cooling

- No moving parts. Passive cooling.

Operating temp

- -35°C to +75°C (-31°F to +167°F) - Cold start-up

Storage temp

- -45°C to +85°C (-49°F to +185°F)

Dimensional Line Drawing

All measurements are in millimeters

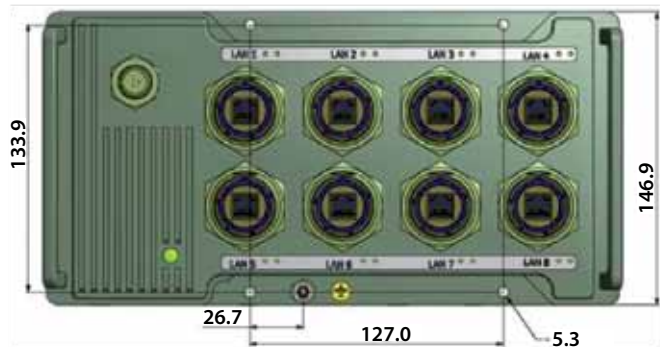

		Description
Part number	RJSMLAC 8MG CAPS	<ul style="list-style-type: none"> • MIL-STD Rugged • 8 x 10/100/1000TX with RJFTV • Managed switch • With caps

NEW

RESMLAC-8MG

Managed Military Ethernet Switch, MIL-DTL-38999 connectors 8 Gigabit ports

Military ethernet switch for harsh environment - Fully MIL-STD-compliant

Amphenol's RESMLAC 8MG is a MIL-STD Fully managed Military-grade network switch offering 8 triple speed (10/100/1000) ports.

Developed for military and harsh environment applications, the RESMLAC 8MG features mechanical packaging enhancements designed for MIL-STD-810F airborne and ground environmental compliance and high reliability. The unit has been especially hardened to improve ingress, impact, and shock/vibration protection, as well as eliminate all moving parts through passive cooling, and interface through sealed MIL-DTL-38999 circular connectors.

Leveraging best-in-class switching technology from, the RESMLAC 8MG serves as a robust solution for providing local area network (LAN) connectivity to IP-enabled computing and net-centric devices. Compact in size, the RESMLAC 8MG is particularly useful for expanding port density in space-constrained airborne and ground vehicle environments.

Military Applications

- Data Acquisition & Transmission
- Battlefield communication C4ISR
- Rugged Networks
- Mobile communications
- Combat vehicles
- Avionic & Shipboard systems



Key Features

- **Ethernet ports**
 - Managed 8 x switched 10/100/1000 ports
- **Networking**
 - Spanning tree (802.1d), RSTP (802.1w) and multiple
 - Spanning tree (802.1S) for fast recovery rings
 - Security via Radius Authentication 802.1x, port security, port mirroring
 - Multicasting (IGMP Snooping), GARP, GMRP, and GVRP, Broadcasting and flooding control up to 8K groups.
 - 802.1q tagged based VLAN up to 4K VLAN groups.
 - QoS multi-layer classifier, 802.1p, ToS/DSCP traffic classification. WFQ, Strict Queuing.
 - Bridge support for Q-in-Q.
 - Link aggregation 802.3AD.
 - WEB, CLI, Telnet management.
- **Connectors**
 - Power connector type: MIL-DTL-38999/24WA98PA
 - LAN connector type: MIL-D-38999/24WB35SN
 - LED indication per port (Speed, Link/Activity)
- **Chassis**
 - Low profile rugged aluminium extrusion
 - Conductively cooled w/custom internal heat-sinks
 - Ingress protection against sand, dust and moisture
 - Anodize Coating, MIL-A-8625, Type II, Class 2
- **Standards**
 - MIL-STD-1275, MIL-STD-704A, MIL-STD-461E,
 - MIL-STD-810F GM, IP67
- **Voltage operation**
 - 24VDC (18VDC ~ 32VDC)

MILITARY RUGGED SWITCH
 MIL-STD-1275
 MIL-STD-704A
 MIL-STD-461E
 MIL-STD-810F/GM
 IP67

Product specifications

Performance

- 26.8 Mpps wire speed forwarding rate
- 20 Gbps maximum forwarding bandwidth
- 8K MAC address

Standards compliance

- IEEE 802.1x MAC based Authentication
- IEEE 802.1Q Vlan Tagging
- IEEE 802.1P QoS
- IEEE 802.1S Multiple STP
- IEEE 802.1W Rapid STP
- IEEE 802.1AD Link Aggregation
- IEEE 802.1X

Power

- Exceed MIL-STD-1275B Surge and Spike protection
- Voltage input: 24Vdc nominal (18-32V)
- Power consumption : 7W typical
- Chassis grounding

Electromagnetic

- MIL-STD-461E Electromagnetic compatibility
- RE-02, RS-03

Environmental : shock/vibration/humidity

- MIL-STD-810F, 501.4I, 501.4II, 502.4I, 502.4II, 507.4, 500.4II, 514, 516I, 516VI, 514.5, 512.4 IP67

Physical

- Dimensions: 269mm(L) x 133(W) x 79(H), including connectors & hardware
- Weight: 1.5 kg

Installation

- Set of four 4.5 mounting holes on bottom for mounting to any flat surface.
- Carrying handles

Cooling

- No moving parts. Passive cooling.

Operating temp

- -35°C to +75°C (-31°F to +167°F) - Cold start-up

Storage temp

- -45°C to +85°C (-49°F to +185°F)

Dimensional Line Drawing

All measurements are in millimeters

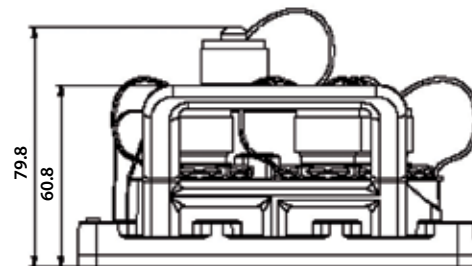
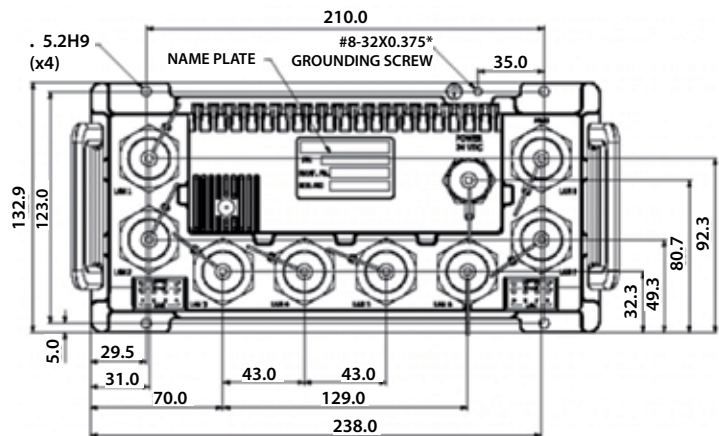
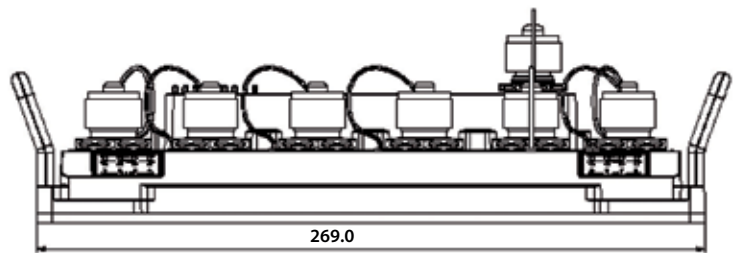

Part number	Description
RESMLAC 8MG CAPS	<ul style="list-style-type: none"> • MIL-STD Rugged • 8 x 10/100/1000TX • Managed switch • with caps
RESMLAC 8MG CBL 1M50	<ul style="list-style-type: none"> • Starter cable set for RESMLAC • MIL-D-38999 to RJ-45 connectors • 1m50 (5 feet) length

RESMLAC-28MG

Managed Military Ethernet Switch - 24 Gigabit + 4 combo 10G ports

Military ethernet switch for harsh environment - Fully MIL-STD compliant

The RESMLAC-28MG is a MIL-STD Fully managed Military-grade network switch offering 24 triple speed (10/100/1000) ports + 4 x 10G fiber ports.

The RESMLAC-28MG is compatible with all the newest military industry network protocols for redundant link topology, security, multi-cast and management requirements.

Developed specifically for military and harsh mobile applications, the RESMLAC-28MG features mechanical packaging enhancements designed for MIL-STD-810F airborne and ground environmental compliance and high reliability. The unit has been especially hardened to improve ingress, impact, and shock/vibration protection, as well as eliminate all moving parts through passive cooling, and interface through sealed MIL-D-38999 circular connectors and SCE.

Leveraging best-in-class switching technology, the RESMLAC-28MG serves as a robust COTS solution for providing local area network (LAN) connectivity to IP-enabled computing and net-centric devices. Compact in size, the RESMLAC-28MG is particularly useful for expanding port density to tactical IP routers in space-constrained airborne and ground vehicle environments.

Military Applications

- Data Acquisition & Transmission
- Battlefield communication C4ISR
- Rugged Networks
- Mobile communications
- Combat vehicles
- Avionic & Shipboard systems



Features

■ Ethernet ports

- Managed 24 x switched 10/100/1000 ports (including 4 Combo ports) + 4x10Gbps Fiber ports - Total of 28 ports.
- The 4 Combo ports provide alternative 4 ports 100/1000Base-FX ports

■ Networking

General

- Wire-speed hardware-based 28 ports gigabit ethernet switch
- Multicasting (IGMP Snooping), GARP, GMRP, MLD and GVRP
- Multicast groups up to 8K for both IPv4 and IPv6
- Broadcasting and flooding control up to 8K groups
- 802.1q tagged based VLAN up to 4K VLAN groups
- Link Aggregation 802.3ad, up to 16 members in group
- Link Aggregation mechanism based on L2/ L3/ L4 parameters
- Jumbo Frame support up to 10K
- WEB, CLI, Telnet Management

Quality of Service

- QoS Multi-Layer Classifier: 802.1p, EtherType, VLAN-ID, IPv4/ 6 DSCP/ ToS, and UDP/TCP ports & ranges traffic classification
- Per port WFQ and Strict Queuing scheduling
- DSCP remarking for both IPv4 and IPv6 frames
- Ingress policer and ingress shaper per port with 500Kbps granularity
- Egress shaper per port with 500Kbps granularity
- Full-duplex flow control (IEEE802.3X) and half-duplex backpressure, symmetric and asymmetric.

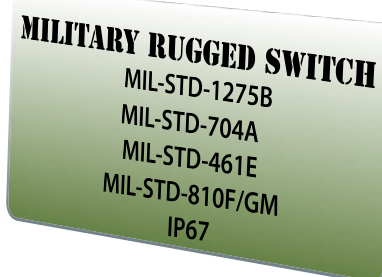

...

Security

- Security via Radius Authentication 802.1x, Port/MAC access control
- Port security
- Per port ingress and egress port mirroring
- Mirroring per VLAN and per content awareness match
- Private VLAN support per VLAN (Isolated and Promiscuous ports)
- Content Aware Policers:
 - 128 Content Aware Policers
 - 16 Content Aware rate policers with rates from 1fps to 32 million fps
 - 8 UDP/TCP port range policers
 - Advanced ACL through hardware based match patterns
 - Content Aware Policers for generic MAC, ARP, IPv4, IPv6 protocols
 - No restriction on any mix of entries to Content Aware Policers
 - Content Aware Policers actions are permit/deny, police, count, snoop and mirror
 - Special support for IP fragments, UDP/TCP port ranges and ARP
 - Extensive CPU DoS prevention
 - Surveillance functions by Content Aware Policers counters
 - Multiple ACLs per port for optimal usage of Content Aware Policers
- Storm controllers for flooded broadcast, multicast and unicast

Redundancy and ring protection

- Spanning tree (802.1d), RSTP (802.1w) and multiple Spanning tree (802.1s) for fast recovery rings
- RPR for up to 30 units per ring with recovery time <50ms hardware based
- RPR for up to 30 units per ring with recovery time <50ms hardware
- 20-Gbps bandwidth for ring topology
- QoS consistency across stack / ring
- Mirroring across stack / ring
- Link aggregation groups spanning multiple switches in stack/ring

Connectors

- 2 x Power connector type: MIL-DTL-38999/24WC4P
- 24 x LAN connector type: SCE2-B-76A07-14SN-001 (4 ports are Gigabit Combo ports - 10/100/1000 or 1000FX fiber)
- 4 x LAN Fiber connectors type: MIL-D-38999 TVOP
- 1 x Serial interface, shared with LAN port #1
- LED indication per Port (Speed, Link/Activity) per Unit (Power A, Power B)

Dimensional Line Drawing

All measurements are in millimeters

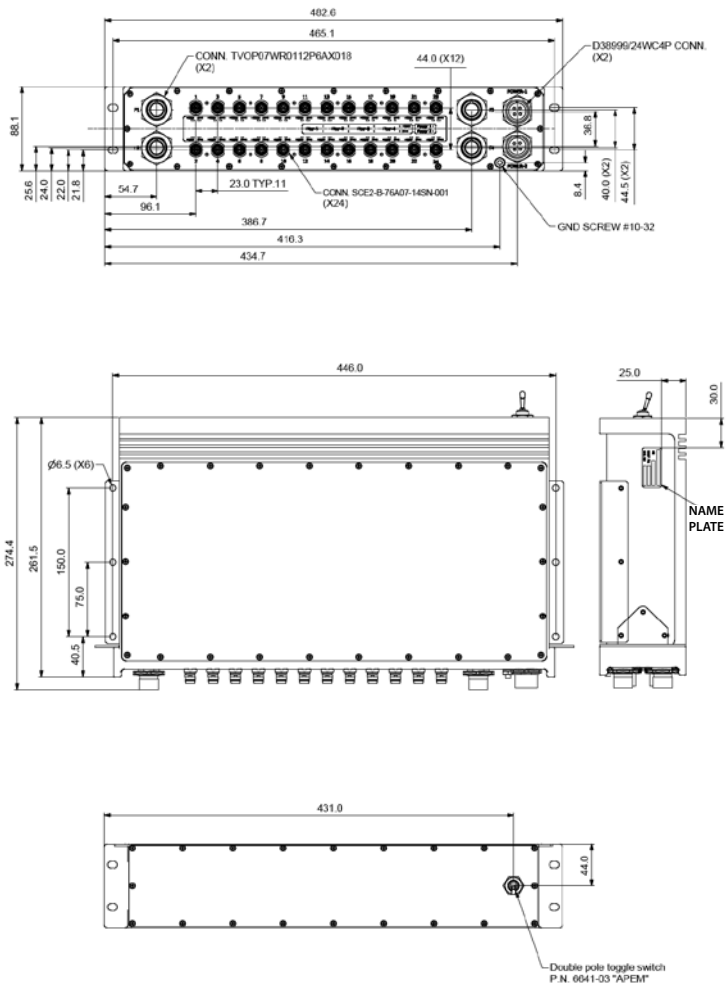

■ Chassis

- Low profile rugged aluminium extrusion
- Conductively cooled w/custom internal heat-sinks
- Ingress protection against sand, dust and moisture
- Anodize Coating, MIL-A-8625, Type II, Class 2

■ Standards

- MIL-STD-1275B, MIL-STD-704A, MIL-STD-461E, MIL-STD-810F GM, IP67
- Support up to 50ms holdup time, and 6VDC drops

■ Voltage operation

- Redundant with load sharing Power Supplies 24VDC, 48VDC, or 90~230VAC

■ Performance

- 96.8 Mbps wire speed forwarding rate
- 56 Gbps maximum forwarding bandwidth
- 8K MAC address

■ Power

- Exceed MIL-STD-1275B and MIL-STD-704A Surge and Spike protection with 50ms holdup time and 6VDC drops
- Voltage input: 24Vdc nominal (18-32V), option for redundant Power supply, 48VDC, and 90~230VAC
- Power consumption: 20W typical
- Chassis grounding

■ Electromagnetic

- MIL-STD-461E Electromagnetic compatibility
- CE-102, CS-114, CS-115, CS-116, RE-102, RS-103

■ Shock / Vibration / Humidity

- MIL-STD-810F, 501.4I, 501.4II, 502.4I, 502.4II, 507.4, 500.4II, 514, 516I, 516VI, 514.5, 512.4

■ Physical

- Dimensions: 440mm (L) x 200mm (W) x 88(H), including connectors & hardware, 2U, 19" rack
- Weight: 5.6 kg

■ Installation

- Set of four 4.5mm mounting holes on bottom for mounting to any flat surface
- 19" standard mounting ears

■ Cooling

- No moving parts. Passive cooling.

■ Operating temp

- -35°C to +75°C (-31°F to +167°F) cold start-up

■ Storage temp

- -45°C to +85°C (-49°F to +185°F)

		Description
Part number	RESMLAC 28MG	<ul style="list-style-type: none"> • Managed Military Grade Gigabit Switch • 24 x 10/100/1000TX
	Options	→ Consult us for options such as additional ports 4 x Up to 10G Fiber ports
	RES-SCE-CBL-1M50	<ul style="list-style-type: none"> • Starter cable set for RESMLAC28MG • SCE to RJ-45 connectors • 1m50 (5 feet) length



Military Ethernet Media Converter For harsh environment, fully MIL-STD compliant

RES-GMC: Unmanaged Military Ethernet Media Converter - 2 or 4 Gigabit ports
Security Gateway for total Network Isolation

Amphenol's RES-GMC is a MIL-STD rugged, Unmanaged-military-grade Security Gateway, offering up to 2 Gigabit security gateways per device for Unidirectional and data diodes solution for total isolation between two network with different security classification. The unit supports PoE on 2 ports (IEEE802.3af and IEEE802.3at).

Developed for military and harsh environment applications, the RES-GMC features mechanical packaging enhancements designed for MIL-STD-810F airborne and ground environmental compliance and high reliability.

The unit has been especially hardened to improve ingress, impact, and shock/vibration protection, as well as eliminate all moving parts through passive cooling, and interface through sealed MIL-D-38999 circular connectors.

Leveraging best-in-class switching technology, the RES-GMC series serves as a robust solution to extend your Tactical Gigabit Ethernet network connectivity of up to 120Km over fiber. Compact in size, the RES-GMC is particularly useful for remote and space-constrained locations either on ground vehicle environments or airborne.

- Military Applications**
- Data Acquisition & Transmission
 - Battlefield communication C4ISR
 - Rugged Networks
 - Combat vehicles
 - Avionic & Shipboard systems

- Key Features**
- **Ethernet ports**
 - 10/100/1000 Base TX to 100/1000 Base FX-(MM/SM) Network isolator
One way data flow for total isolation between classified and unclassified networks
 - Up to 2 security gateways per device over optical fiber
 - **Networking**
 - Full wire-speed forwarding rate
 - Option for Up to 2 ports PoE - IEEE802.3af, IEEE802.3at
 - Auto MDI-II, MDI-X, FDX, HDX, Flow control
 - Auto-negotiation and fixed settings via DIP switch
 - Jumbo Frame support
 - Option for one way fiber security
 - **Connectors**
 - MIL-D-38999 (Power & Ethernet signals)
 - Power connector type: D38999/24WA98PN
 - LAN connector type: D38999/24WB35SN (2 ports model) or RJFTV (1 port model)
 - Fiber connector type: TVOP arrangement 11-02
 - **Chassis**
 - Low profile rugged aluminium extrusion
 - Conductively cooled w/custom internal heat-sinks
 - Ingress protection against sand, dust and moisture
 - Anodize Coating, MIL-A-8625, Type II, Class 2
 - **Standards**
 - MIL-STD-1275, MIL-STD-704A, MIL-STD-461E,
 - MIL-STD-810F GM, IP67
 - **Voltage operation**
 - 24VDC (18VDC ~ 36VDC), 48VDC for PoE versions

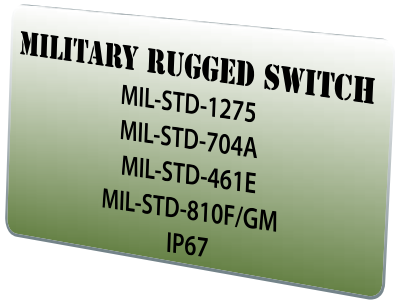

Product specifications

Performance

- 26.8 Mpps wire speed forwarding rate
- 20 Gbps maximum forwarding bandwidth
- 4K MAC address
- 2 LED indication (Speed, Link/Activity) per port
- Wire-speed reception and transmission

Standards compliance

- IEEE 802.3, 10 Mbps 10BASE-T (Ethernet)
- IEEE 802.3u, 100 BASE-TX 100 Mbps (Fast Ethernet)
- IEEE 802.3ab, 1000Base-TX
- IEEE 802.3z, 1000Base-FX Gigabit
- IEEE 802.3af, IEEE802.3at

Power

- MIL-STD-1275B & MIL-STD-704A Surge and Spike protection
- Voltage input: 24Vdc nominal (18-36V)
- Power consumption: 2.8W typical
- Chassis grounding

Electromagnetic

- MIL-STD-461E Electromagnetic compatibility

Environmental : shock/vibration/humidity

- MIL-STD-810F, 501.4I, 501.4II, 502.4I, 502.4II, 507.4, 500.4II, 514, 516I, 516VI, 514.5, 512.4
- IP67

Physical

- Dimensions: 170mm(L) x 150(W) x 65(H), including connectors & hardware
- Weight: 1.5 kg

Installation

- Set of Four 4x4.5 mounting holes on bottom for mounting to any flat surface.
- Carrying handles - Optional

Cooling

- No moving parts. Passive cooling.

Operating temp

- -35°C to +75°C (-31°F to +167°F) - Cold start-up

Storage temp

- -45°C to +85°C (-49°F to +185°F)

Dimensional Line Drawing

All measurements are in millimeters

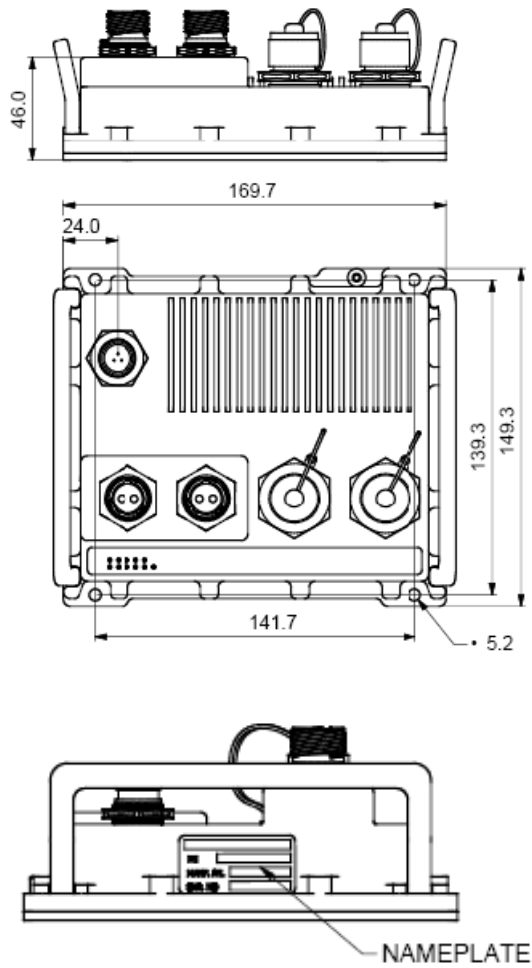

		Description
Part number	RES-GMC-1M	<ul style="list-style-type: none"> • RES-GMC • MIL-STD Rugged • 1 x 10/100/1000TX to 1000FX, MM, SX, Media Converter
	RES-GMC-1S	<ul style="list-style-type: none"> • RES-GMC • MIL-STD Rugged • 1 x 10/100/1000TX to 1000FX, SM, LX, 10 KM Media Converter
	RES-GMC-2M	<ul style="list-style-type: none"> • RES-GMC • MIL-STD Rugged • 2 x 10/100/1000TX to 2 x 1000FX, MM, SX, Media Converter
	RES-GMC-2S	<ul style="list-style-type: none"> • RES-GMC • MIL-STD Rugged • 2 x 10/100/1000TX to 2 x 1000FX, SM, LX, 10 KM Media Converter

Rugged USB Solutions



Table of contents

	USBFTV (USB-A)	72
	USBF TV - Transversally sealed receptacles	75
NEW	USBF TV Hermetic receptacles	77
NEW	USBFTV - Receptacles with 360° EMI backshells	78
NEW	USBF TV Through bulkhead	79
	USBF TV Stand off receptacles	80
	USBF TV Self Closing Cap (SCC)	82
	Self Closing Cap (SCC) for USB receptacles	83
	USBF SC - Quick release series	84
	USBBF TV (USB-B)	86
NEW	USBBF TV Stand off receptacles	89
	USBBF TV - Transversally sealed receptacles	91
NEW	Self Closing Cap (SCC) for USBB receptacles	92
NEW	Special USB adaptor for Military & Commercial Aeronautics	93
	High reliability USB 2.0 Cordsets	94

USBF TV (USB-A)

USB Connection System for Harsh Environment



With USB Field, you can insert a standard USB 2.0 cordset into a metallic plug which will protect it from shocks, dust and fluids.

No hazardous on-field cabling and grounding!

This metallic plug is connected into a receptacle, using a Tri Start Thread coupling mechanism (MIL-DTL-38999 series III type) with anti-decoupling device for high vibrations.

Applications

- Embedded Computers
- Data Acquisition and transmission in harsh environment
- Railways
- Battelfield Communication Systems
- Navy Systems

Main characteristics

- Sealed against fluids and dusts (IP68)
- Shock, Vibration and Traction resistant
- No cabling operation in field and no tools required
- Improved EMI protection
- Tri Start Thread coupling mechanism (MIL-DTL-38999 series III type) with anti-decoupling device
- 2 mechanical Coding / Polarization possibilities by the user (receptacle insert rotation)
- USBF TV plug retention in the receptacle: 100 N in the axis
- Mating cycles: 500 minimum

Environmental Protection

- Sealing (when mated): IP68 (Temporary immersion)
- Salt Spray: 48 h with Nickel plating
> 500 h with Olive Drab Cadmium
1000 h with marine bronze shell
- Fire Retardant / Low Smoke: UL94 V0 and NF F 16 101 & 16 102
- Vibrations: 10 – 500 Hz, 10 g, 3 axes: no discontinuity > 1micro s
- Shocks: IK06: weight of 250 g drop from 40 cm [15.75 in] onto connectors (mated pair)
- Humidity: 21 days, 43°C, 98% humidity
- Temperature Range: - 40°C / +85°C

Data Transmission

USB Specification 2.0

Data Rate: Up to 480 Mbps for High Speed USB

Part Number Code

Series	USBF TV	2	1	G
USB Field TV				
Shell Type				
6:	Plug			
2:	Square flange receptacle			
2PE:	Square flange receptacle with metal backshell (type 1) & with metal backshell + plastic gland (type 2)			
2PEM:	Square flange receptacle with backshell + metal gland (only for back termination type 2 = Solder)			
7:	Jam nut receptacle			
7PE:	Jam nut receptacle with metal backshell (type 1) & with metal backshell + plastic gland (type 2)			
7PEM:	Jam nut receptacle with backshell + metal gland (only for back termination type 2 = Solder)			
Back Terminations (Receptacles only)				
1:	Female USB-A			
2:	Solder (4 tinned holes)			
Shells Material & Finish				
N:	Aluminium shell - Nickel plating - ROHS compliant			
G:	Aluminium shell - Olive Drab Cadmium plating			
BZ:	Marine bronze shell - ROHS compliant			

- Examples:
- Olive Drab Cadmium Plug: USBF TV 6G
 - Olive Drab Cadmium Square Flange Receptacle, USB-A back terminat^o: USBF TV 21G
 - Olive Drab Cadmium Jam Nut Receptacle, USB-A receptacle back terminat^o: USBF TV 71G
 - Nickel Jam Nut Receptacle, solder back termination: USBF TV 72N

Plug

- Shell type 6

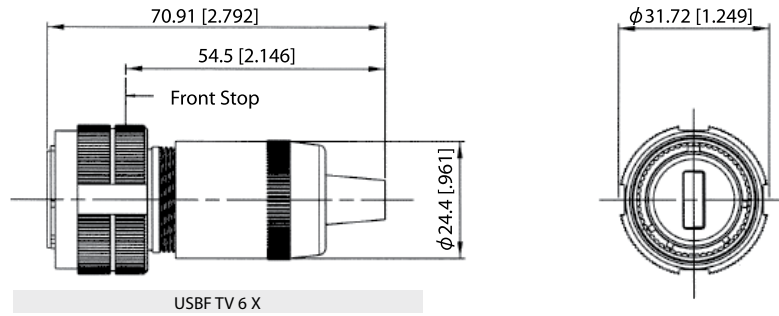

Receptacles

- Square flange receptacle
- 4 mounting holes: Shell type 2

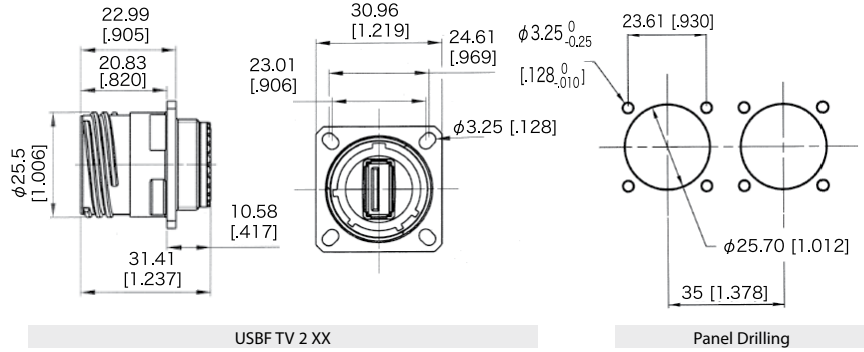

- Jam nut receptacle
- Hexagonal Nut mounting: Shell type 7

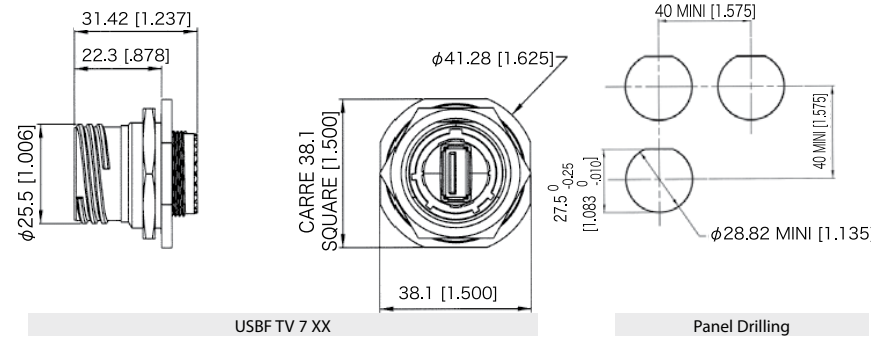

- Receptacles with backshell:
- Shell type 2PE and 7PE

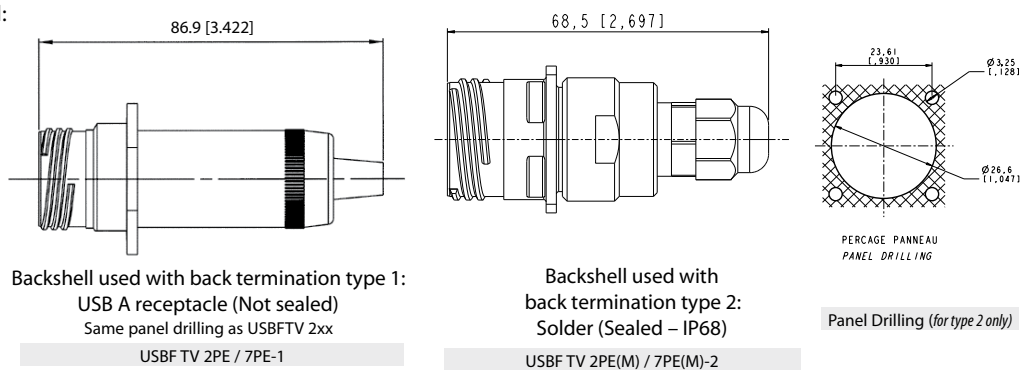

Back terminations

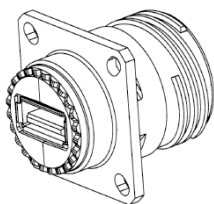

Type 1: Female USB-A

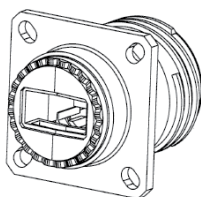

Type 2:
Solder 4 Tinned holes to solder your cable

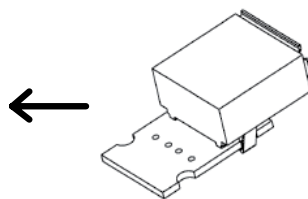

View of the PCB of the Type 2 version with 4 tinned holes for solder termination

Assembly Instructions

Can be used with most the USB cordset brands : No tools required!

Plug Assembly

1. Only if you need a full sealing (IP68): Install the white sticker around the plug, covering the 4 little holes of the overmolding
2. Insert the black O Ring around the front face of the USB A plug. This O Ring will ensure connection sealing
3. Insert the USB cordset into the metallic backshell
4. Insert the retention spacer laterally to the cable (this spacer is soft, in order to adapt to different shapes of overmolding) and slide the overmolding of the USB-A plug into this retention spacer
5. Insert the friction ring laterally to the cable
6. Choose the right coding (2 positions) and insert the USB-A plug into the protective plug. Note at this step, the main key is used for polarization.

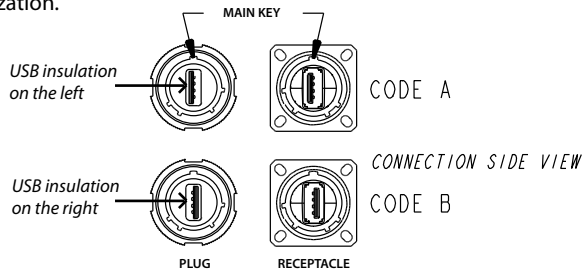

7. Screw the backshell on the plug body. A wrench can be necessary to fully tighten it, and the connection to the receptacle can help

IMPORTANT NOTE

The connection sealing is not done by the black retention spacer (which is slotted), but by the front face ORing (fig.2)

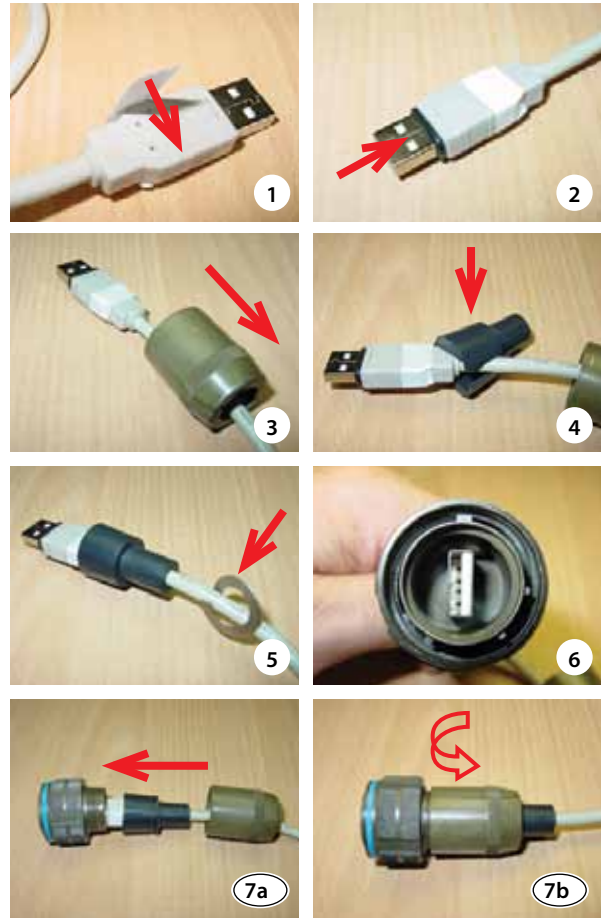

Receptacle Assembly

Insert the USB module from the rear. Reference is main key. Beware to have a coding compatible with the coding you used for the plug: on front view, the white shapes in the USBs must be on the same side.



To remove the USB module, insert the removal tool USBF ODE from the Front, and push back the module.



Accessories

■ Metallic Caps

USBF TVC 2 G

Connector Type

- 6: Plug
- 2: Square Flange Receptacle
- 7: Jam Nut Receptacle

Shells Material & Finish

- N: Aluminium shell - Nickel - ROHS compliant
- G: Aluminium shell - Olive Drab Cadmium
- BZ: Marine bronze shell - ROHS compliant

- Panel Gasket for square flange receptacle (Thickness: 0,8 mm [.031]): JE15



- Receptacle Insert removal tool: USBF ODE

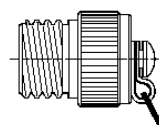

Plug Cap



Receptacle Cap

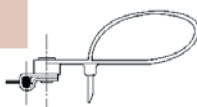

Plug Cap end

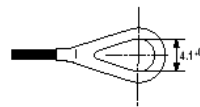

Square flange receptacle cap end



Jam Nut receptacle cap end

USBF TV

Transversally Sealed Receptacles



In some applications, a transversal sealing for the receptacle is a « must ». This will prevent fluids and dust from going through the receptacle when plug or cap are not mated to the receptacle. The sealed solution (version "S") has a compound at the rear of the receptacle below. In addition, the Sealed USBF TV has been successfully tested in very high vibration corresponding to airplane applications.

Applications

- Embedded Computers
- Data Acquisition and transmission in harsh environment
- Railways
- Battelfield Communication Systems
- Navy Systems

Data Transmission

USB Specification 2.0
Data Rate: Up to 480 Mb/s for High Speed USB

Main characteristics

- Sealed against fluids and dusts (IP68)
- Shock, Vibration and Traction resistant
- No cabling operation in field and no tools required
- Improved EMI protection
- Tri Start Thread coupling mechanism (MIL-DTL-38999 series III type) with anti-decoupling device
- 2 mechanical Coding / Polarization possibilities by the user (receptacle insert rotation)
- USBF TV plug retention in the receptacle: 100 N in the axis
- Mating cycles: 500 minimum

Environmental Protection

- Sealing (when mated): IP68 (Temporary immersion)
- Salt Spray: 48 h with Nickel plating
> 500 h with Olive Drab Cadmium
1000 h with marine bronze shell
- Fire Retardant / Low Smoke: UL94 V0 and NF F 16 101 & 16 102
- Vibrations: 10 – 500 Hz, 10 g, 3 axes: no discontinuity > 1 micro s
- Shocks: IK06: weight of 250 g drop from 40 cm [15.75 in] onto connectors (mated pair)
- Humidity: 21 days, 43°C, 98% humidity
- Temperature Range: - 40°C / +85°C

Part Number Code

Series	USBF TV	2PES	A	2	N	03	A
USB Field TV							
Shell Type							
2S:	Square flange receptacle						
2PES:	Square flange receptacle + backshell + plastic gland						
2PEMS:	Square flange receptacle + backshell + metal gland						
7S:	Jam nut receptacle						
7PES:	Jam nut receptacle + backshell + plastic gland						
7PEMS:	Jam nut receptacle + backshell + metal gland						
Coding							
"A" (Standard) or "B"							
Back Terminations							
2:	Rugged USB cable (see corresponding datasheet page 94)						
Shells Plating							
N:	Nickel						
G:	Olive drab cadmium plating						
USB cable length							
03:	30 cm [11.81 inches]						
05:	50 cm [19.68 inches]						
10:	1 meter [39.37 inches]						
USB cable end							
A:	Standard USB-A plug						
OPEN:	Open cable (no connector)						

- Examples:
- Olive Drab Cadmium Square Flange Receptacle with 30 cm of USB cable and standard USB-A plug: USBF TV 2S G 03 A
 - Nickel Jam Nut Receptacle + backshell + plastic gland, with 1 meter of USB cable, and a standard USB-A plug: USBF TV 7PES N10 A

Receptacles

- Square flange receptacle 4 mounting holes: Shell type 2

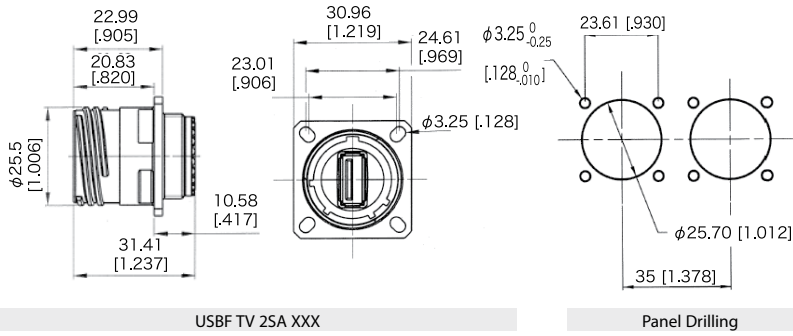

- Jam nut receptacle Hexagonal Nut mounting: Shell type 7

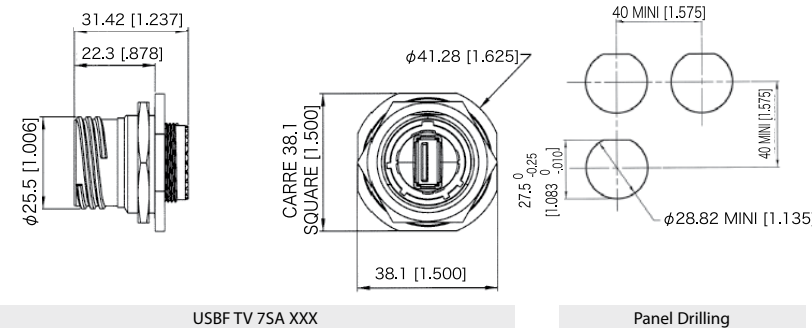

- Jam nut receptacle Hexagonal Nut mounting: Shell type 7

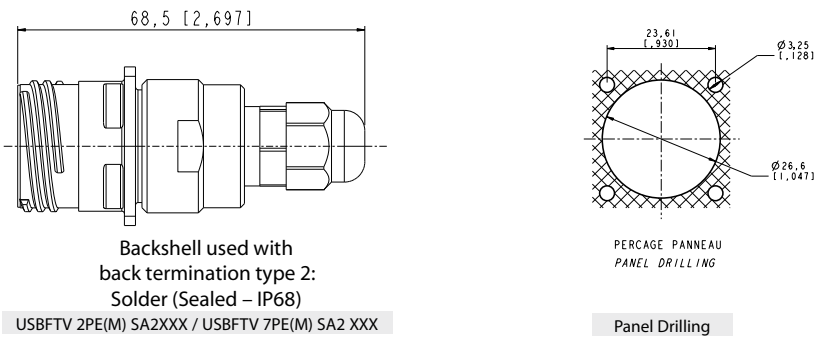

Cordset End

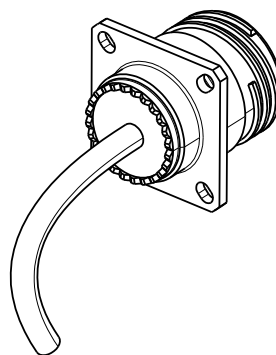
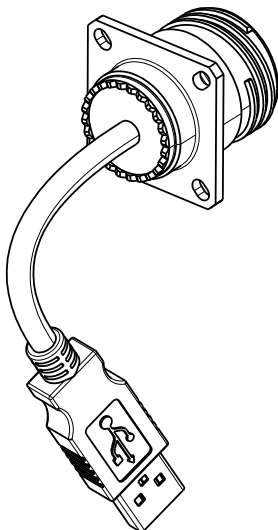



USBF TV

Hermetic Receptacles



In some applications, a transversal hermiticity for the receptacle is a « must ». This will prevent gas from going through the receptacle when plug or cap are not mated to the receptacle. The hermetic solution (version "H") has a compound at the rear of the receptacle. Helium leakage is less than 1.10^{-6} cm³ per second [0.1 micron cubit ft per hour] at one bar [15 psi] pressure differential.

Applications

- Embedded Computers
- Data Acquisition and transmission in harsh environment
- Railways
- Battelfield Communication Systems
- Navy Systems

Data Transmission

USB Specification 2.0
Data Rate: up to 480 Mb/s for High Speed USB

Main characteristics

- Same as the USBF TV (see page 76)... a complete IP68 sealing of the receptacle is added (even with no plug or no protective cap mated).
- Outside dimensions are the same as the standard USBF TV (USB-A).
- Vibrations : the compounded version of the USBF TV has been tested in vibration following the NAS 1599 Aeronautic specification (Ambient temperature): 5 - 3000 Hz, 20g, 2.5 mm [.1 inch] double amplitude, 3 axes, 12 hours
Note: this specification exceeds MIL-C-26500 requirements.

IMPORTANT NOTE

Due to the compound, the coding of the connector must be done in the factory: use the codes A or B in the part number. **Example:** USBFTV 2H **A** 2 N 03 A

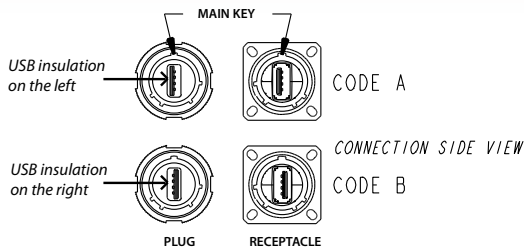

Part Number Code

Series	USBF TV	2H	A	2	N	03	A
USB Field TV							
Shell Type							
2H :	Hermetic square flange receptacle						
2PEH:	Hermetic square flange receptacle + backshell + plastic gland						
2PEMH:	Hermetic square flange receptacle + backshell + metal gland						
7H:	Hermetic jam nut receptacle						
7PEH:	Hermetic jam nut receptacle + backshell + plastic gland						
7PEMH:	Hermetic jam nut receptacle + backshell + metal gland						
Coding							
"A" (Standard) or "B"							
Back Terminations							
2:	Rugged USB cable (see corresponding datasheet page 94)						
Shells Plating							
N:	Nickel						
G:	Olive drab cadmium plating						
USB cable length							
03:	30 cm [11.81 inches]						
05:	50 cm [19.68 inches]						
10:	1 meter [39.37 inches]						
USB cable end							
A:	Standard USB-A plug						
OPEN:	Open cable (no connector)						

Examples: - Olive Drab Cadmium Hermetic Square Flange Receptacle with 30 cm of USB cable and standard USB-A plug: USBF TV 2H G 03 A
- Nickel Hermetic Jam Nut Receptacle + backshell + plastic gland, with 1 meter of USB cable, and a standard USB-A plug: USBF TV 7PEH N10 A



USB TV

Receptacles with 360° EMI backshells



USBFTV Receptacles series with EMI backshells provide 360° shielding: same protection than the one proposed per Standard MIL-DTL-38999 serie III Connectors. We offer these EMI backshells with square flange and jam nut receptacles. The available platings are nickel or olive drab cadmium. With those solutions we suggest using our reinforced USB cable (shielded – zero halogen jacket). See page 94.

We can provide those receptacles:

- with cordset already soldered
- without cordset

Example with a square flange receptacle (provided without cable)

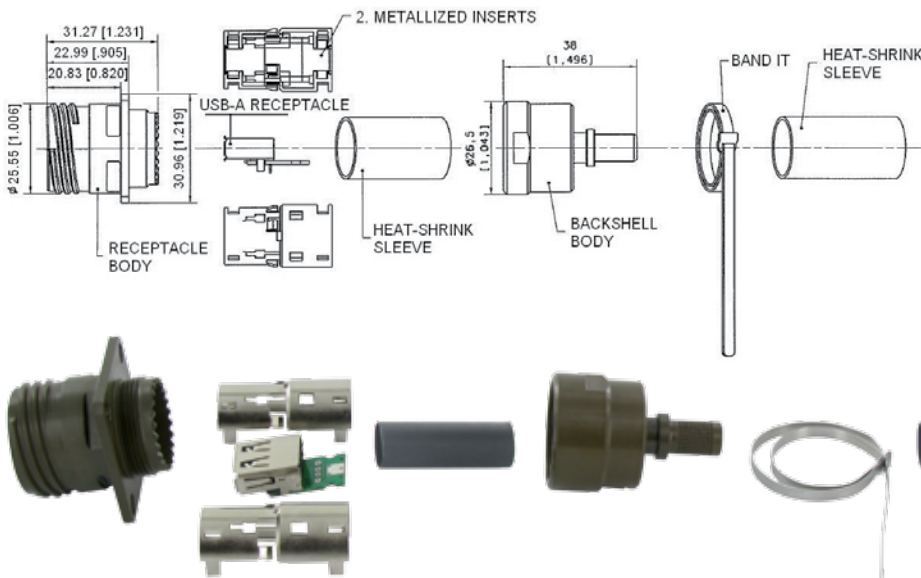

Part number	Plating	Square flange receptacle	Jam nut receptacle
	Nickel	KIT40263	KIT40245
Olive drab cadmium	KIT40263G	KIT40245G	

IMPORTANT NOTE

With receptacles provided without cable, customer will have to solder his cable on the PCB ; please find below the cabling specification.

If customer prefers to use his cable, please check with us compatibility with our EMI backshells: www.usbfield.com

WIRES AND SHIELDING WIRE CABLING ON THE PCB

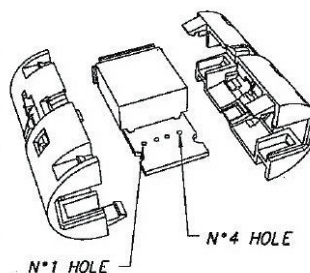
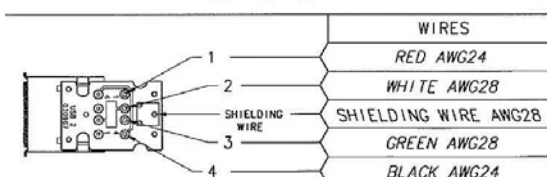



USBF TV

Through bulkhead

Receptacle

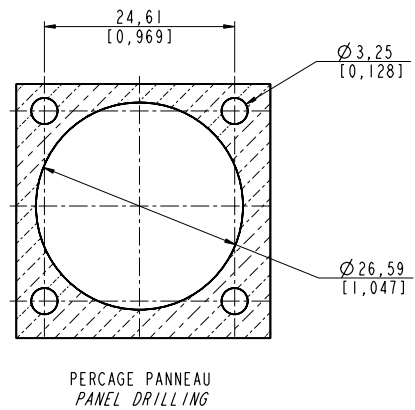
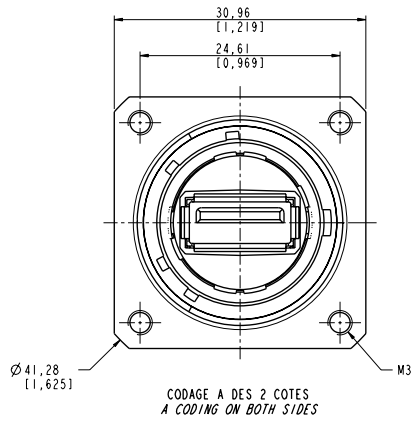
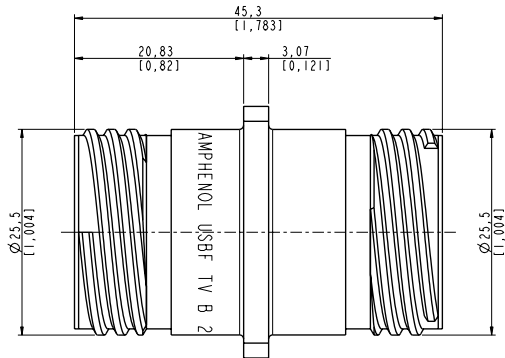

Part number	Plating	P/N
	Nickel	USBF TV B 2 N
	Olive drab cadmium	USBF TV B 2 G

Nota : could be used with plug USBFTV, nickel and olive drab cadmium. See page 72.

USBF TV

Stand off receptacles

These receptacles can be soldered directly to your PCB. A compound insures a transversal sealing and good performance in high-vibration environments.
The shell of those receptacles are in the "Stand Off" style.
They can be connected with rugged USBF TV series plugs.

Square flange receptacle

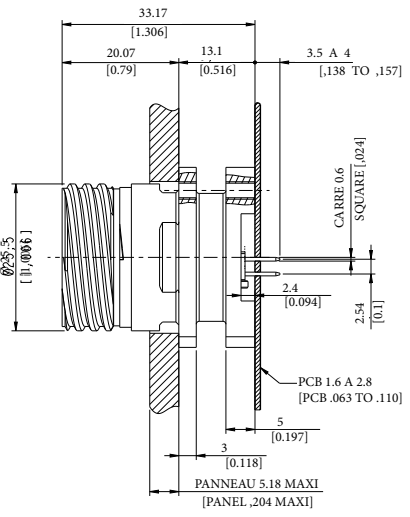

Datas for Coding A

Coding B is also available, please consult us.

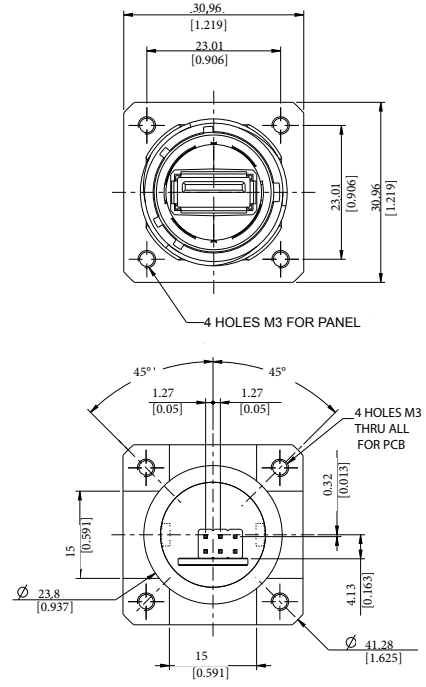

Part number	Plating available	P/N for coding A	P/N for coding B
	Nickel	USBF TV 25 N F459	USBF TV 25 B 5 N F459
	Olive Drab Cadmium	USBF TV 25 G F459	USBF TV 25 B 5 G F459

Connection side view

Main key

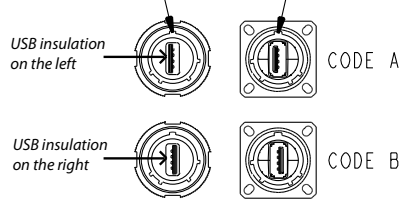

Plug Receptacle

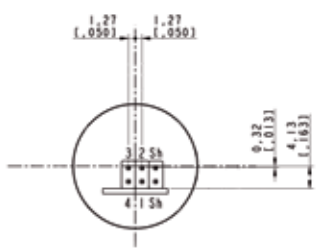

Coding A - Pins position :
1 & 4 = Power - Red & black wires USB2.0 cable
2 & 3 = Signal - White & green wires USB2.0 cable
Sh = Shield

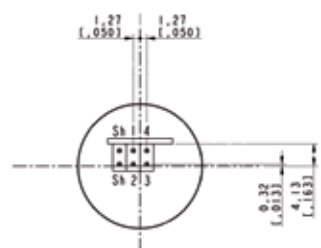

Coding B - Pins position :
1 & 4 = Power - Red & black wires USB2.0 cable
2 & 3 = Signal - White & green wires USB2.0 cable
Sh = Shield

Recommended PCB hole LAYOUT (Coding A) - Solder side view

Nota : for coding B, please consult us.

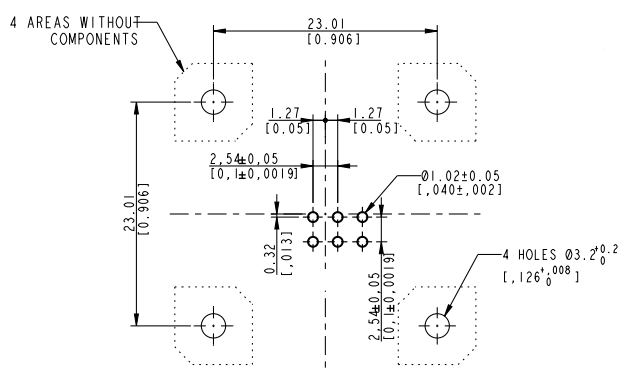

Panel Drilling

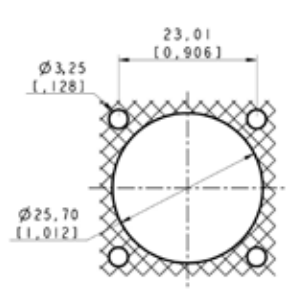

Jam nut receptacle

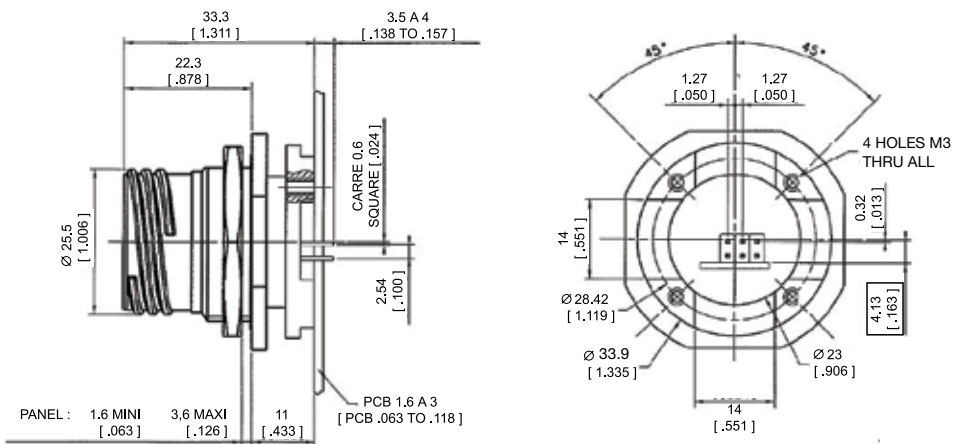

Part number	Plating available	P/N for coding A	P/N for coding B
	Nickel	USBF TV 75 N F459	USBF TV 75 B 5 N F459
Olive Drab Cadmium	USBF TV 75 G F459	USBF TV 75 B 5 G F459	

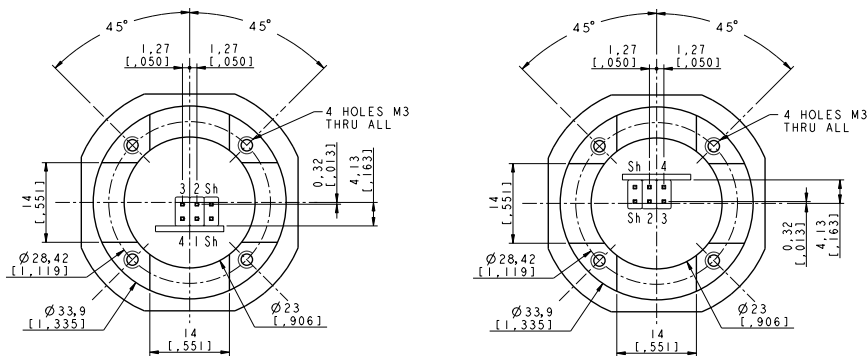
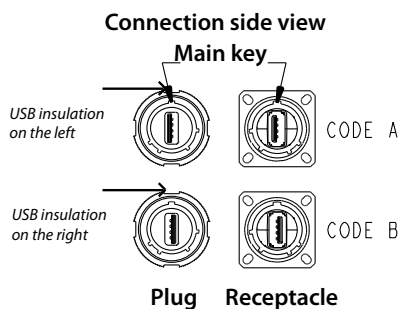

Coding A - Pins position :
1 & 4 = Power - Red & black wires USB2.0 cable
2 & 3 = Signal - White & green wires USB2.0 cable
Sh = Shield

Coding B - Pins position :
1 & 4 = Power - Red & black wires USB2.0 cable
2 & 3 = Signal - White & green wires USB2.0 cable
Sh = Shield

Recommended PCB hole LAYOUT

Solder side view

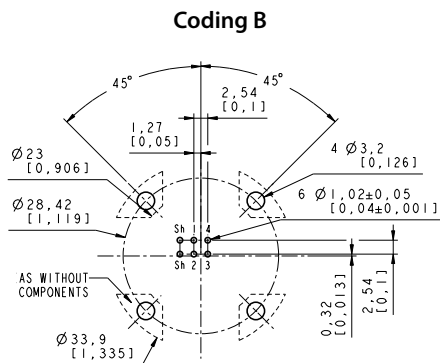
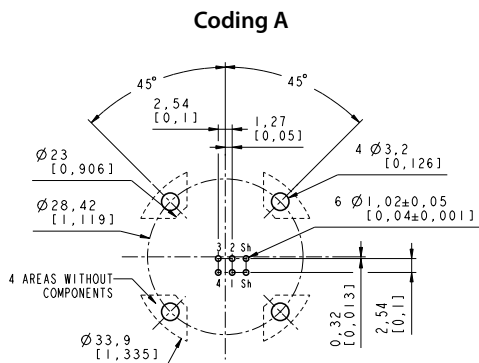

Panel Drilling

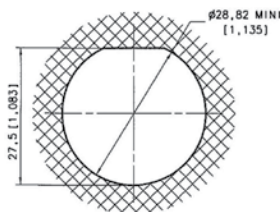

USBF TV

Self Closing Cap (SCC Series)

This Self Closing cap automatically protects the USBF TV (type A) & USBBF TV (type B) square flange receptacles (MIL-DTL-38999 type), protecting your system from dust and water projection. A spring automatically closes the upper part of the cap when the USB plug is removed from the receptacle. IP67.

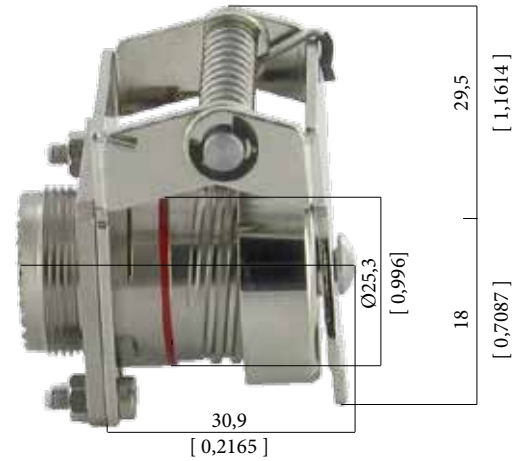
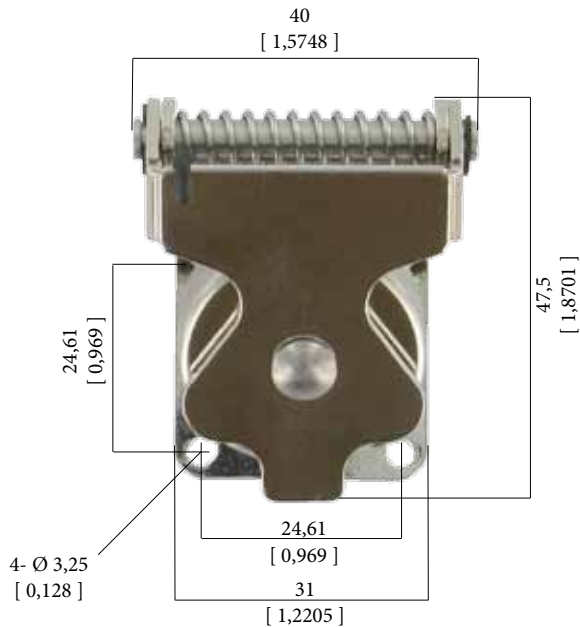

IMPORTANT NOTE

Metal Self Closing cap are sold separately (without receptacle).



Part number	Plating available	P/N
	Black	USBFTVSCCB
Nickel	USBFTVSCCN	
Olive drab cadmium	USBFTVSCCG	

Remark: compatible with USBFTV (type A) & USBBF TV (type B) square flange receptacle only:
 USBFTV2XX (see page 74)
 USBBF TV2XX (see page 88)

■ Panel Gasket for square flange receptacle
 (Thickness: 0,8 mm [.031]):

Part number: JE15



Self Closing Cap

For USB Receptacles

Sealing level IP54
(Splash and dust Proof)



This Self Closing Cap automatically protects the RJ Field square flange receptacles (MIL-C-26482 type), protecting your system from dust and water projections. The same cap can be used to protect USB and IEEE1394 receptacles. A spring automatically closes the upper part of the cap when either the RJ Field plug, RJ45 cordset, USB or IEEE1394 cordset, or USB key are removed from the receptacle.

USBF 21 X SCC

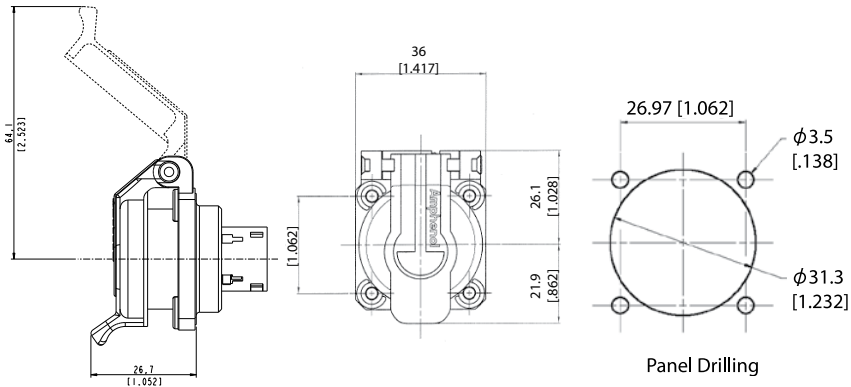

Version: **USB-A** (front and back termination)

Part number *	Plating		Metallized inserts (EMI)	
	Part number *	Plating	Metallized inserts (EMI)	
USBF 21B SCC	Black coated	No (blank insert)		
USBF 21N SCC	Nickel plated	Yes		
USBF 21G SCC	Olive drab cadmium plated	Yes		

* The part number includes the receptacle + the self closing cap

■ **Note:** Panel gasket with any of these receptacles: JE18



RJF 21 X SCC, USBF 21 X SCC, & IEEE1394



RJ45 version
(see page 23)



USB-B version
(see page 92)



IEEE1394 version
(see page 117)

USBF SC

Quick release series



This product offers a new coupling solution, particularly for applications requiring quick disconnect. The system consists of a circular spring within in the receptacle keeping the plug mated, and creating an internal coupling mechanism.

Applications

- Embedded Computers
- Data Acquisition and transmission in harsh environment
- Railways
- Battelfield Communication Systems
- Navy Systems

Main characteristics

- Sealed against fluids and dusts (IP67)
- Shock, Vibration and Traction resistant
- No cabling operation in field and no tools required
- Improved EMI protection
- Mating cycles: 500
- Mating force after 500 cycles: 40 N
- Unmating force after 500 cycles: 55 N

Environmental Protection

- Sealing (when mated): IP67 (Temporary immersion)
- Salt Spray: 48 h with Nickel plating
> 500 h with Olive Drab Cadmium
- Fire Retardant / Low Smoke: UL94 V0 and NF F 16 101 & 16 102
- Vibrations: 10 – 500 Hz, 10 g, 3 axes: no discontinuity > 1 micro s
- Shocks: IK06: weight of 250 g drop from 40 cm [15.75 in] onto connectors (mated pair)
- Humidity: 21 days, 43°C, 98% humidity
- Temperature Range: - 40°C / +85°C

Data Transmission

USB Specification 2.0
Data Rate: Up to 480 Mb/s for High Speed USB

Part Number Code

Series	USBF SC	2	1	G
USBF Spring Loaded				
Shell Type				
6: Plug				
1: Inline receptacle				
2: Square flange receptacle				
7: Jam nut receptacle				
Back Terminations (Receptacles only)				
1: Female USB-A				
2: Solder (4 tinned holes) - Not available for shell type "1" (Inline receptacle)				
Shells Material & Finish				
N: Aluminium shell - Nickel plating - ROHS compliant				
G: Aluminium shell - Olive Drab Cadmium plating				
BZ: Marine bronze shell - ROHS compliant				

Back terminations

USBFSC Back Terminations Receptacles

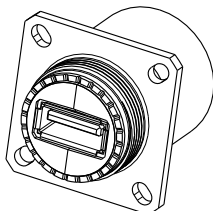

Type 1: Female USB-A

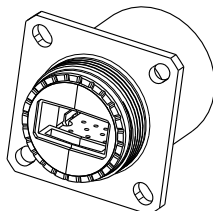

Type 2: Solder (4 tinned holes)

Plug

■ Shell type 6

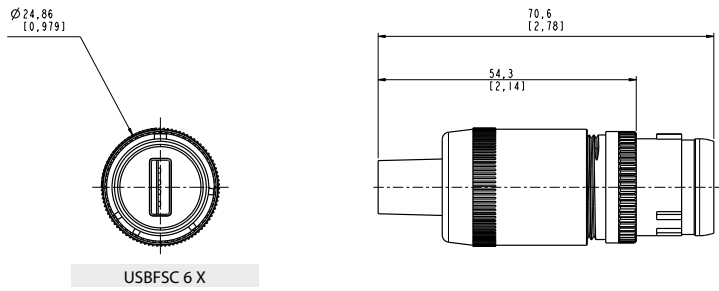

Receptacles

■ Square flange receptacle 4 mounting holes: shell type 2

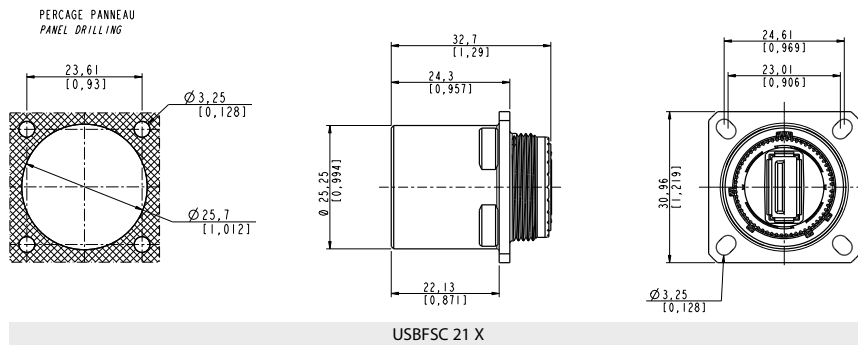

■ Jam nut receptacle hexagonal nut mounting: shell type 7

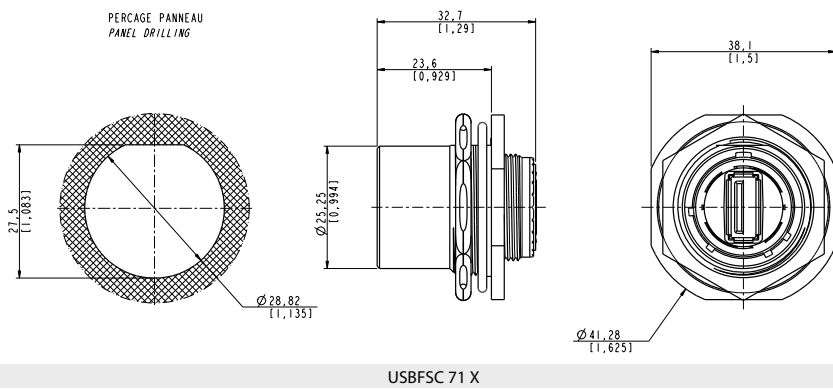

■ Inline receptacle: shell type 1

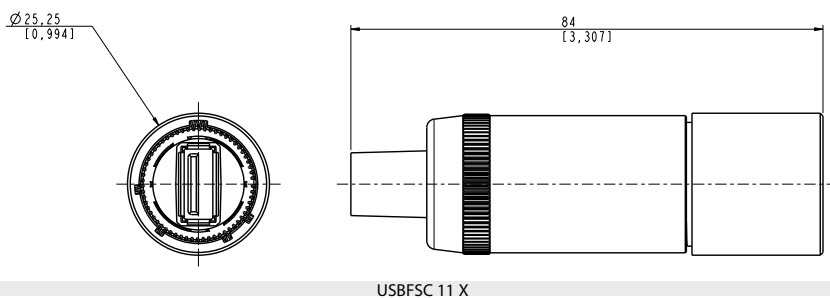

USBBF TV (USB-B)

USB Connection System for Harsh Environment



Applications

- Embedded Computers
- Data Acquisition and transmission in harsh environment
- Railways
- Battelfield Communication Systems
- Navy Systems

Data Transmission

USB Specification 2.0
Data Rate: Up to 480 Mb/s for High Speed USB

USB Field allows you to use a standard USB 2.0 connection in harsh environment:

- Sealed against fluids and dusts (IP68)
- Shock, Vibration and Traction resistant
- No cabling operation in field and no tools required
- Improved EMI protection
- Tri Start Thread coupling mechanism (MIL-DTL-38999 series III type) with anti-decoupling device
- Plug retention in the receptacle: 100N in the axis
- Mating cycles: 500 minimum

Back terminations available:

- a USB-A receptacle
- solder: 4 tinned holes on the PCB to solder your wire

Temperature range: -40°C/+85°C

Part Number Code

Series	USBBF TV	2	1	G
USBB Field TV				
Shell Type				
6:	Plug			
2:	Square flange receptacle			
2PE:	Square flange receptacle with metal backshell (type 1) & with metal backshell + plastic gland (type 2)			
2PEM:	Square flange receptacle metal gland (only for soldering back termination type 2)			
7:	Jam nut receptacle			
7PE:	Jam nut receptacle with metal backshell (type 1) & with metal backshell + plastic gland (type 2)			
7PEM:	Jam nut receptacle metal gland (only for soldering back termination type 2)			
Back Terminations (Receptacles only)				
1:	Female USB-A			
2:	Solder (4 tinned holes)			
Shells Material & Finish				
N:	Aluminium shell - Nickel plating - ROHS compliant			
G:	Aluminium shell - Olive Drab Cadmium plating			

- Examples:
- Plug-cadmium plating: USBBF TV 6G
 - Square Flange Receptacle-USB-A back terminat° -cadmium plating: USBBF TV 21G
 - JamNut Receptacle, solder terminat° -nickel plating: USBBF TV 72N

Back terminations

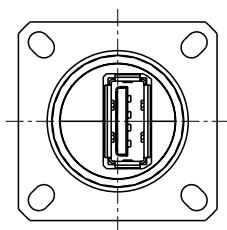

Type 1: Female USB-A

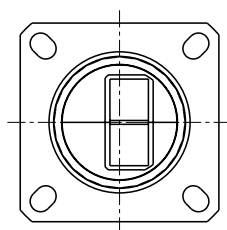

Type 2: Solder (4 tinned holes)

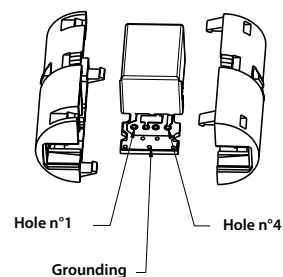

Plug

■ Shell type 6

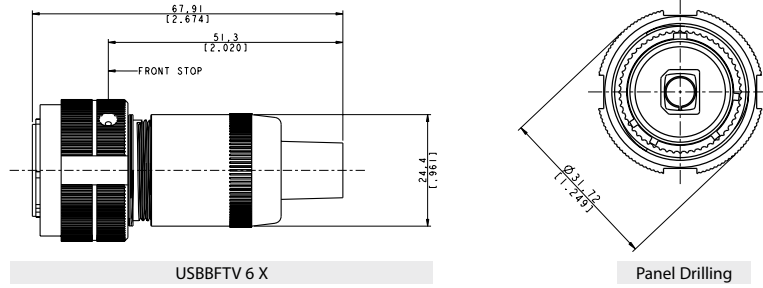

Receptacles

■ Shell type 2 - Square flange receptacle

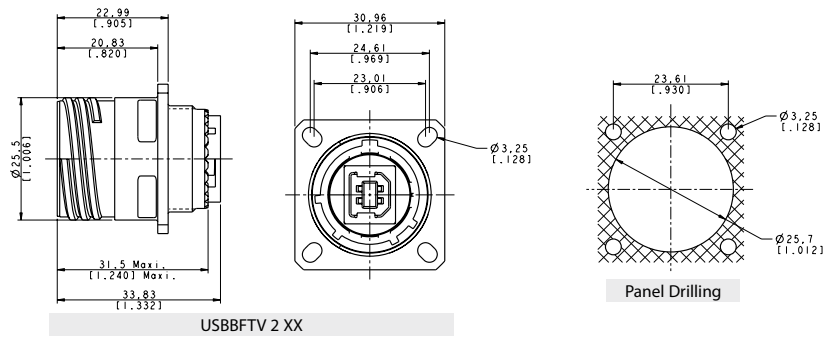

■ Shell type 7 - Jam nut receptacle

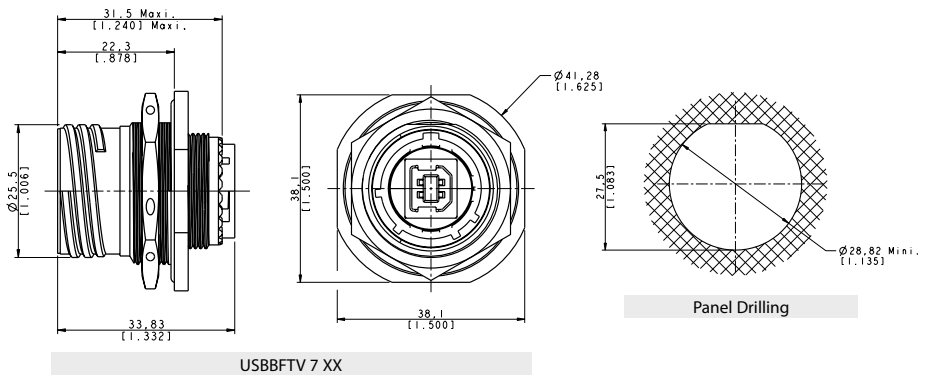

■ «2PEM» and «7PEM» Shells with Backshell to protect Back termination from dust, shocks and vibration.

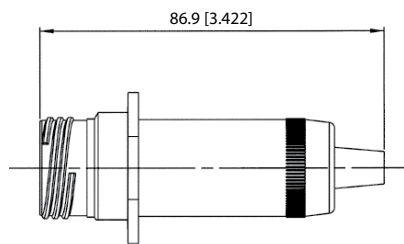

Backshell used with back termination type 1:
USB A receptacle (Not sealed)

Same panel drilling as USBBFTV 2xx
USBBFTV 2PE / 7PE-1

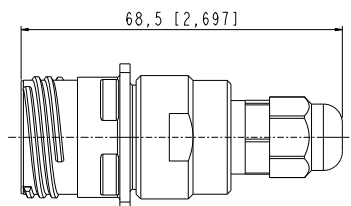

Backshell used with
back termination type 2:
Solder (Sealed - IP68)

USBBFTV 2PE(M) / 7PE(M)-2

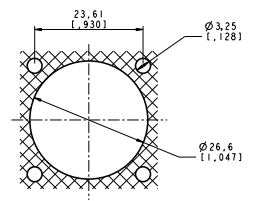

PERÇAGE PANNEAU
PANEL DRILLING

Panel Drilling (for type 2 only)

Accessories

■ Metallic Caps (same as USB-A version - see page 74)

	USBFTVC	2	G
Connector Type			
6:	Plug		
2:	Square Flange Receptacle		
7:	Jam Nut Receptacle		
Shells Material & Finish			
N:	Nickel plating - ROHS compliant		
G:	Olive Drab Cadmium plating		

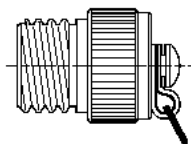

Plug Cap

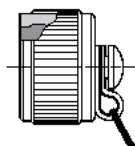

Receptacle Cap

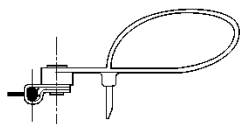

Plug Cap end

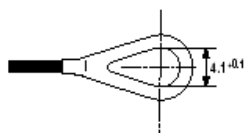

Square flange
receptacle cap end

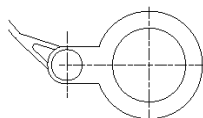

Jam Nut receptacle
cap end

- Panel Gasket for square flange receptacle
(Thickness: 0,8 mm [.031]): JE15





USBBF TV

Stand off Receptacles

These receptacles can be soldered directly to your PCB. A compound insures a transversal sealing and good performance in high-vibration environments. The shell of those receptacles are in the "Stand Off" style. They can be connected with USBBF TV series plugs.

Square flange receptacle

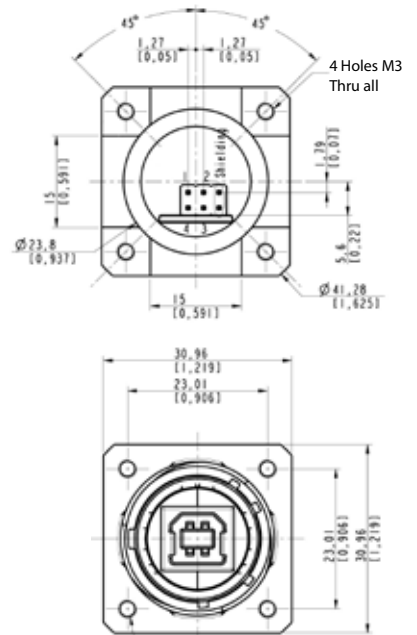
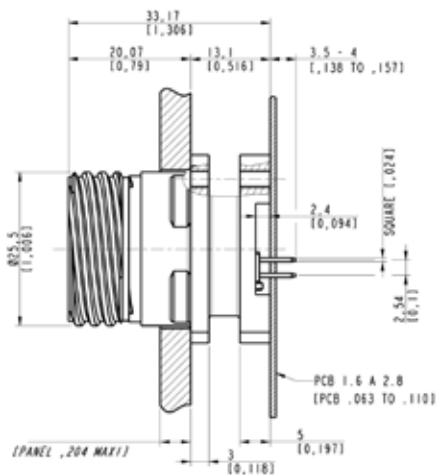

Part number	Plating available	Part number
	Nickel	USBBF TV 2 5 N F459
	Olive Drab Cadmium	USBBF TV 2 5 G F459

Recommended PCB hole LAYOUT

Solder side view

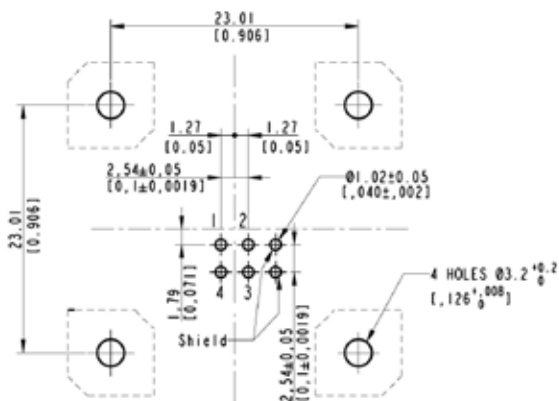

Panel Drilling

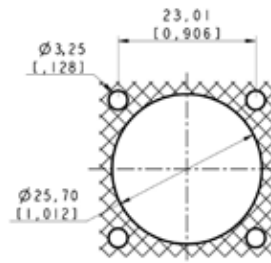

Jam nut receptacle

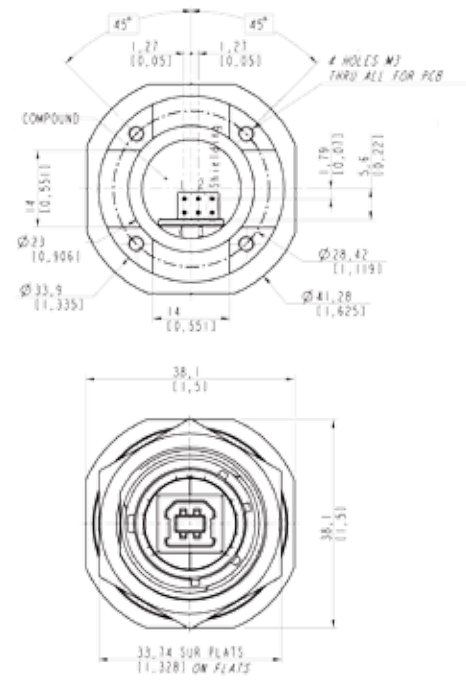
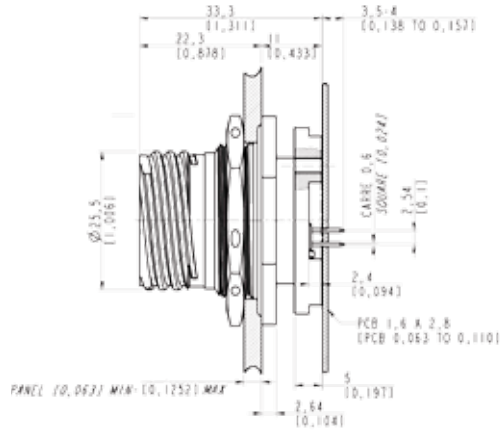

Part number	Plating available	Part number
	Nickel	USBBF TV 7 5 N F459
Olive Drab Cadmium	USBBF TV 7 5 G F459	

Recommended PCB hole LAYOUT

Solder side view

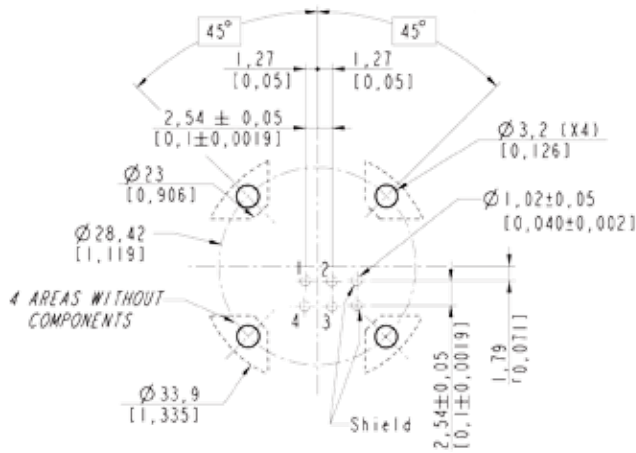

Panel Drilling

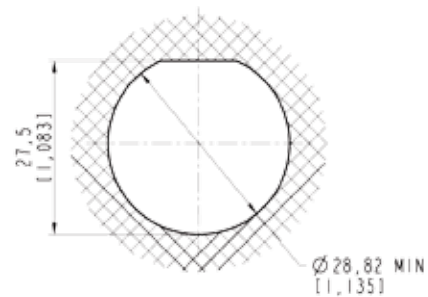

USBBF TV

Transversally sealed Receptacles



Applications

- Embedded Computers
- Data Acquisition and transmission in harsh environment
- Railways
- Battelfield Communication Systems
- Navy Systems

With USB Field, you can insert a standard USB 2.0 cordset into a metallic plug which will protect it from shocks, dust and fluids.

No hazardous on-field cabling and grounding!

This metallic plug is connected into a receptacle, using a Tri Start Thread coupling mechanism (MIL-DTL-38999 series III type) with anti-decoupling device for high vibrations.

Main characteristics

- Sealed against fluids and dusts (IP68)
- Shock, Vibration and Traction resistant
- No cabling operation in field and no tools required
- Improved EMI protection
- Tri Start Thread coupling mechanism (MIL-DTL-38999 series III type) with anti-decoupling device
- 2 mechanical Coding / Polarization possibilities by the user (receptacle insert rotation)
- USBF TV plug retention in the receptacle: 100 N in the axis
- Mating cycles: 500 minimum

Environmental Protection

- Sealing (when mated): IP68 (Temporary immersion)
- Salt Spray: 48 h with Nickel plating
> 500 h with Olive Drab Cadmium
1000 h with marine bronze shell
- Fire Retardant / Low Smoke: UL94 V0 and NF F 16 101 & 16 102
- Vibrations: 10 – 500 Hz, 10 g, 3 axes: no discontinuity > 1micro s
- Shocks: IK06: weight of 250 g drop from 40 cm [15.75 in] onto connectors (mated pair)
- Humidity: 21 days, 43°C, 98% humidity
- Temperature Range: - 40°C / +85°C

Data Transmission

USB Specification 2.0

Data Rate: Up to 480 Mb/s for High Speed USB

Part Number Code

Series	USBBF TV	7S	2	G	10	OPEN
USBB Field TV						
Shell Type						
2S:	Sealed Square flange receptacle					
2PES:	Sealed Square flange receptacle + backshell + plastic gland					
2PEMS:	Sealed Square flange receptacle + backshell + metal gland					
7S:	Sealed Jam nut receptacle					
7PES:	Sealed Jam nut receptacle with backshell					
7PEMS:	Sealed Jam nut receptacle + backshell + metal gland					
Back Terminations						
2:	Rugged USB cable					
Shells Plating						
N:	Nickel					
G:	Olive drab cadmium					
USB cable length						
03:	30 cm [11.81 inches]					
05:	50 cm [19.68 inches]					
10:	1 meter [39.37 inches]					
USB cable end						
A:	Standard USB-A plug					
OPEN:	Open USB cable (no connector)					

- Examples:
- Olive Drab Cadmium Jam Nut Receptacle: USBBF TV 7 XX
 - Nickel Square Flange Receptacle: USBBF TV 2 XX

SELF CLOSING CAP

For USBB Receptacles

Sealing level IP54
(Splash and dust Proof)



This Self Closing Cap automatically protects the RJ Field square flange receptacles (MIL-C-26482 type), protecting your system from dust and water projections. The same cap can be used to protect USB and IEEE1394 receptacles. A spring automatically closes the upper part of the cap when either the RJ Field plug, RJ45 cordset, USB or IEEE1394 cordset, or USB key are removed from the receptacle.

USBBF 21 X SCC

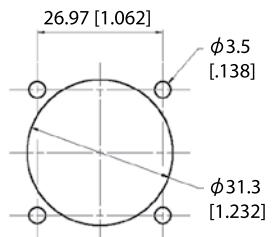
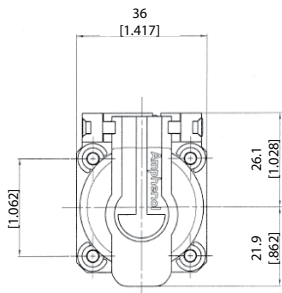
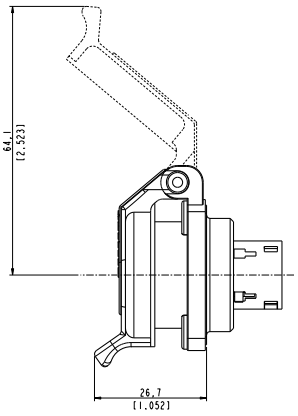

Panel Drilling

Version: **USB-B** (front in USB-B and back termination in USB-A)

Part number *	Plating	Metallized inserts (EMI)
USBBF 21B SCC	Black coated	No (blank insert)
USBBF 21N SCC	Nickel plated	Yes
USBBF 21G SCC	Olive drab cadmium plated	Yes

* The part number includes the receptacle + the self closing cap

■ **Note:** Panel gasket with any of these receptacles: JE18



RJF 21 X SCC, USBF 21 X SCC, & IEEE1394



RJ45 version
(see page 23)



USB-A version
(see page 83)



IEEE1394 version
(see page 117)



Special USB adaptor

For Military & Commercial Aeronautics

Adaptor USB only

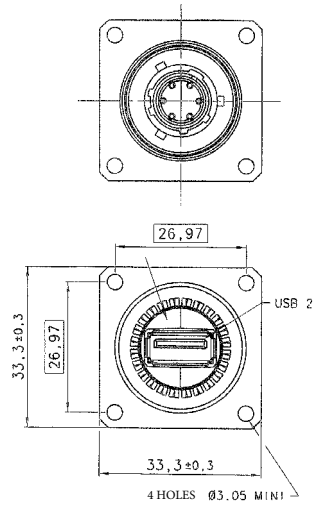
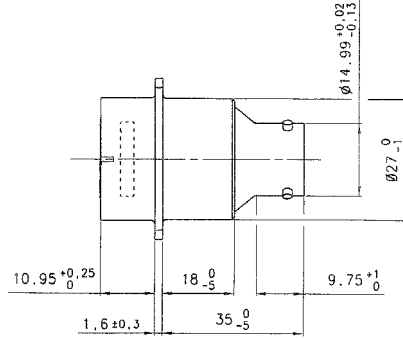

Part number	Coding
35608	N
35615	W

Adaptor USB + Self Closing Cap (SCC)

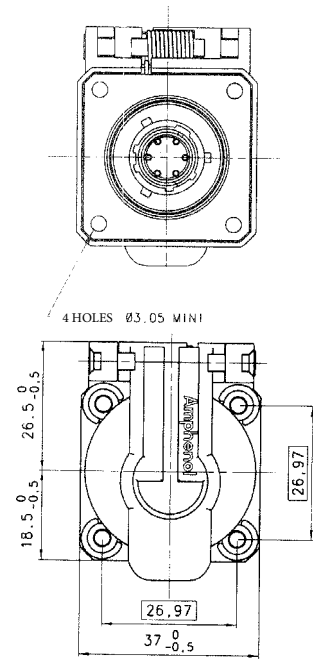
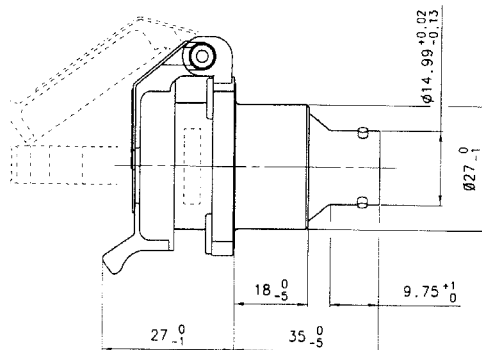

Part number	Coding
35616	N
35617	W

For all options:

10-6 Male contact EN3155

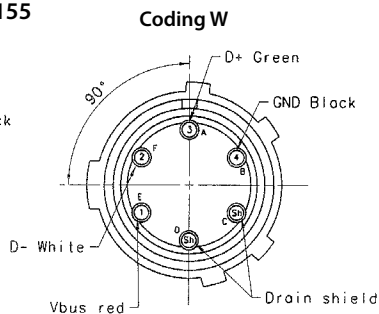
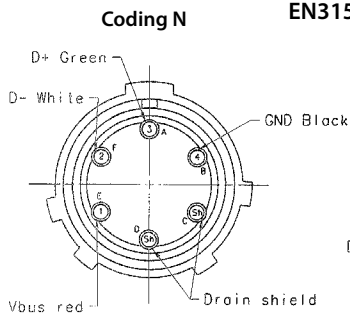

Panel Drilling

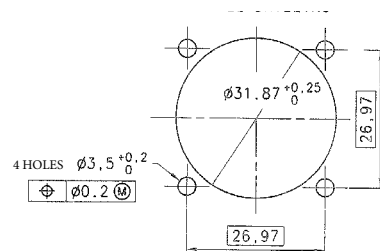

High Reliability USB 2.0 Cordsets



General Construction: this is a USB-2.0 cable containing one 28 AWG 90Ω characteristic impedance data pair, two 24 AWG power conductors, overall SFTP shields (SFTP = double shielding, braid and foiled), jacketed in black UV resistant Polyurethane HFFR*. Designed for fixed or portable applications in industrial and harsh environments.
 *HFFR: Halogen Free Flame Retardant.

Jacket Compound Specification:
 Halogen Free Flame Retardant Polyether-based Polyurethane. Glossy finish. Excellent hydrolysis resistance. High microbial resistance. UV resistant. High flexibility.

- Applications**
- Robotics
 - Motion Control
 - Railways
 - CNC Machines
 - Battelfield communication
 - Industrial Process

Data
for cable alone only
(without USB plug)

PHYSICAL CHARACTERISTICS	
DATA CONDUCTORS	bare copper, 7/0.12 mm nom (28 AWG)
DATA INSULATION	0.9 mm nom
COLOR DATA PAIR	Green & white
POWER CONDUCTORS	Tinned copper, 7/0.2 mm (24 AWG)
POWER INSULATION	1.1 mm nom
COLOR POWER WIRE	Red & Black
SHIELDS	Foil: providing 100% coverage, in contact with tinned copper drain wire and an overall braid providing 65% nom. coverage made of 16x5/0.1 mm tinned copper strands
JACKET	PU compound
COLOR JACKET	Black
WEIGHT	26 lbs/mft (38 kg/km)
OUTSIDE DIAM.	0.20 inch (5.1 mm nom. +/- 0.15)
MIN BEND RADIUS <i>(During installation)</i>	45.9 mm (9x O. D.)
MIN BEND RADIUS <i>(During operation)</i>	25.5mm (5 x O.D.)
TEMPERATURE installation	Plus 60°C, minus 5°C
TEMPERATURE operational	Plus 85°C, minus 40°C

CORDSETS WITH A USB A PLUG OVERMOLDED ON EACH END (OUT OF USB SPECIFICATION > 5 M)	
Length (m/ft)	Part Number
6 m / 19.68 ft	USB2 AA 600 PU HFFR
7 m / 22.96 ft	USB2 AA 700 PU HFFR
8 m / 26.24 ft	USB2 AA 800 PU HFFR
9 m / 29.52 ft	USB2 AA 900 PU HFFR
10 m / 32.80 ft	USB2 AA 1000 PU HFFR

REEL OF DRUM (WITHOUT USB PLUG ON ENDS)	
Length	PN
300 m / ~ 984 ft	190-040567-00

ELECTRICAL CHARACTERISTICS	
DC RESISTANCE	94 Ohms/Km @ 20°C
IMPEDANCE	90 +/- 13 Ohms 1-400 MHz
ATTENUATION	
1 KHZ	8 db/100m max.
4 MHZ	15.6 db/100m max.
24 MHZ	38 db/100m max.
96 MHZ	76 db/100m max.
200 MHZ	128 db/100m max.
400 MHZ	232 db/100m max.
CAPACITANCE 2X28 AWG	
CAPACITANCE	54pF/m nom. @ 1KHz
CAPACITANCE UNBALANCE	2.0 pF/m max. @ 1KHz (wire to ground)
DIELECTRIC STRENGTH	VAC/1 min - 500 V/Min
RESISTANCE UNBALANCE	2% max. @ 20°C
VELOCITY OF PROPAGATION	65% min. 68% max.



CORDSETS WITH A USB A PLUG OVERMOLDED ON EACH END (UNDER USB SPECIFICATION ≤ 5M)	
Length (m/ft)	Part Number
0.5 m / 1.64 ft	USB2 AA 050 PU HFFR
1 m / 3.28 ft	USB2 AA 100 PU HFFR
1.50 m / 4.92 ft	USB2 AA 150 PU HFFR
2 m / 6.56 ft	USB2 AA 200 PU HFFR
2.50 m / 8.2 ft	USB2 AA 250 PU HFFR
3 m / 9.84 ft	USB2 AA 300 PU HFFR
3.50 m / 11.48 ft	USB2 AA 350 PU HFFR
4 m / 13.12 ft	USB2 AA 400 PU HFFR
4.5 m / 14.76 ft	USB2 AA 450 PU HFFR
5 m / 16.40 ft	USB2 AA 500 PU HFFR

Rugged USB Solutions



Cable assemblies

Table of contents

 USB-A Field : plastic & neoprene solutions with self closing cap	96
 USB-B Field : Plastic shell - Overmolded cordset plug	99



USB-A Field

Rugged USB-A plastic & neoprene solutions with Self Closing Cap



Amphenol USB-A Field - Plastic & Neoprene versions are rugged USB interconnect solutions fitted to be used in any industrial harsh environment. The Self Closing Cap enclosure enables to protect the USB-A Field receptacle from dust and fluids when the plug or the USB Memory key are unmated.

Applications

- Access point
- Telecom equipments
- Video control
- Robotics
- Industrial process control
- CNC machines
- Special machines

Main characteristics

- Sealing level:
 - Matted condition with plug or rugged USB Memory Key : IP67
 - Receptacle with Self Closing Cap alone : IP54
- Mating cycles: 500
- Push / Pull mating
- Neoprene shells for plug & USB Keys
- Data transmission: USB Specification 2.0
- Data rate: up to 480 Mb/s for High Speed USB
- Temperature range: -40°C / +85°C
- RoHS compliant

Memory Key with soft neoprene shell



IP67 when matted on receptacle or with neoprene protective cape

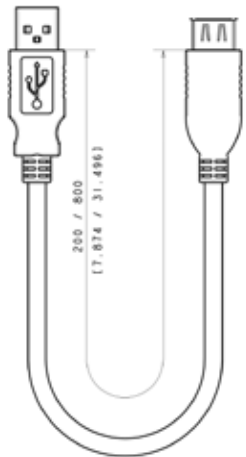
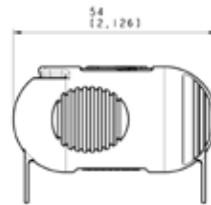
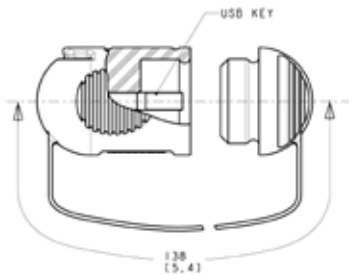
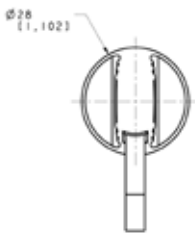

Part number	Capacity (Mb)	
	USBAPKEY 2048	2048
	USBAPKEY 4096	4096
USBAPKEY 8192	8192	

Plug with soft neoprene shell



Part number:
USBAP 6 xxxA
with USB-A plug

IP67 when matted
on receptacle

Part number:
USBAP 6 xxx
Open

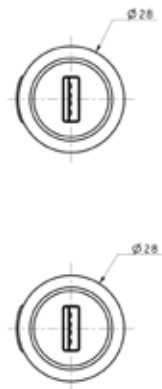
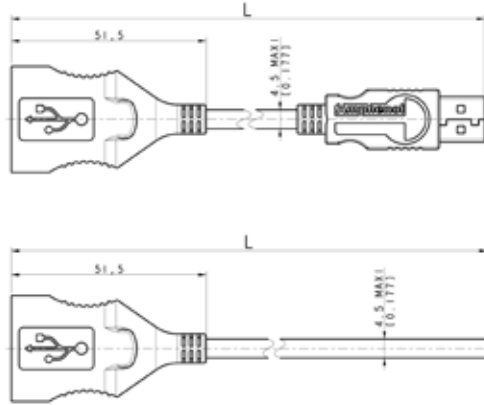

Part number	Extremity type Open or USB-A	L +5cm 0	L +0.164ft 0
		Meters	Feet
USBAP6 05 OPEN	Open	0.5	1.64
USBAP6 05A	USB-A	0.5	1.64
USBAP6 10 OPEN	Open	1.0	3.28
USBAP6 10A	USB-A	1.0	3.28
USBAP6 15 OPEN	OPEN	1.5	4.92
USBAP6 15A	USB-A	1.5	4.92
USBAP6 20 OPEN	OPEN	2.0	6.56
USBAP6 20A	USB-A	2.0	6.56

Square flange receptacle



Part number:
USBAPSCC 21

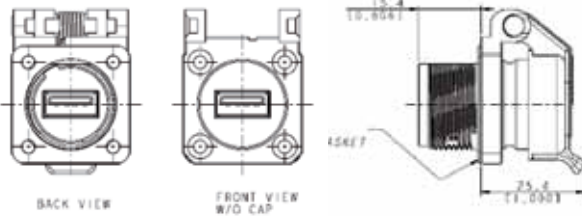

IP54
when alone

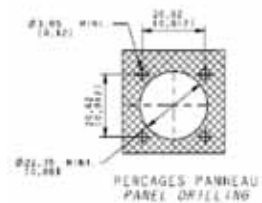
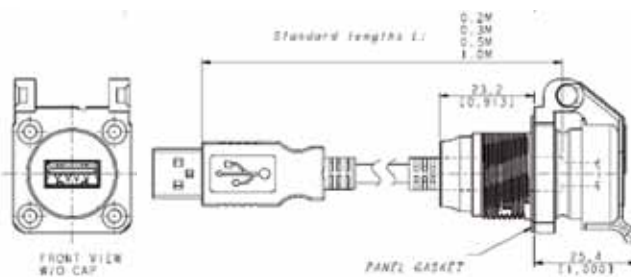
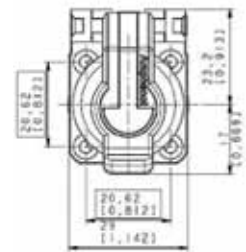

Part number	Cordset length	Cordset length
	Meters	Feet
USBAPSCC 22 02A	0.2	0.66
USBAPSCC 22 03A	0.3	0.98
USBAPSCC 22 05A	0.5	1.65
USBAPSCC 22 10A	1.0	3.28

Jam nut receptacle

**IP54
when alone**

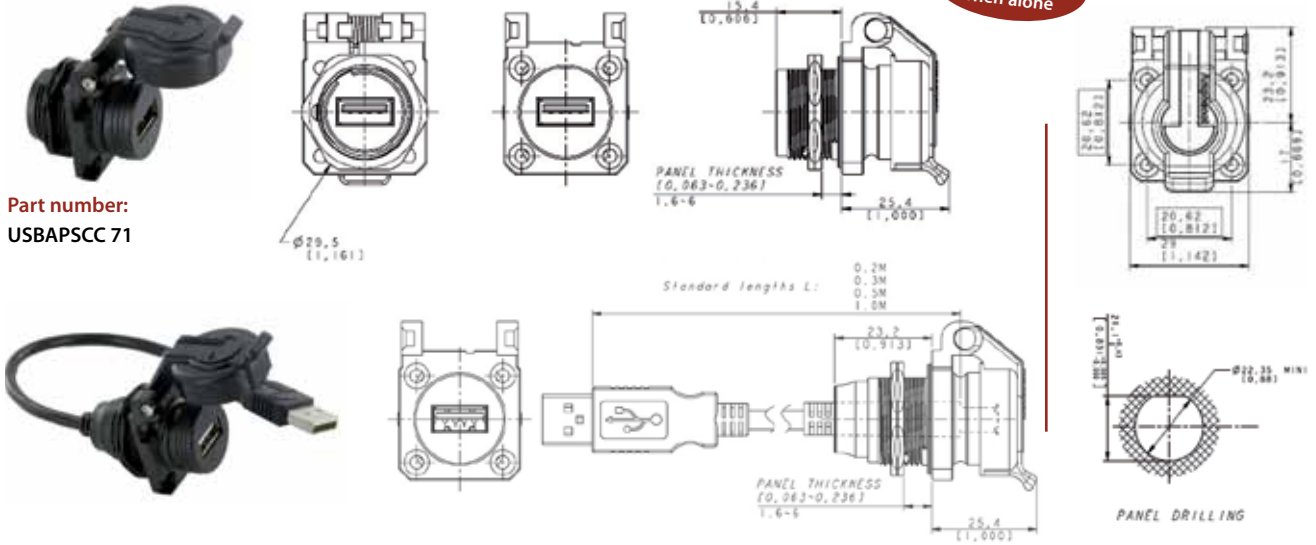

**Part number:
USBAPSCC 71**

Part number	Cordset length	Cordset length
	Meters	Feet
USBAPSCC 72 02A	0.2	0.66
USBAPSCC 72 03A	0.3	0.98
USBAPSCC 72 05A	0.5	1.65
USBAPSCC 72 10A	1.0	3.28

USB plastic - IP67 cap (for square flange receptacle only)

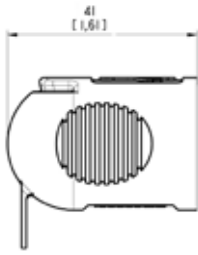

**Part number:
USBAP IP67 CAP**



Cap lanyard fixed by a screw
(for square flange receptacle only)

How to unplug:

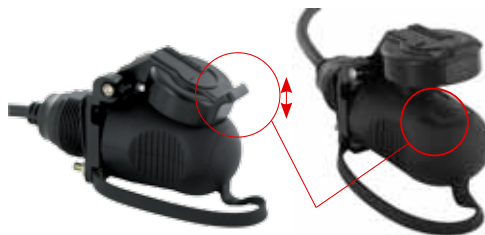

Locking Shape:
Push-up the self-closing cap before removing the USBKey,
Plug or IP67 protective cap from the receptacle



USB-B Field

Plastic shell - Overmolded cordset Plug



IP68 SEALED USB-B CONNECTION SYSTEM

- Plastic shells
- Thread coupling
- Overmolded plug cordset: male sealed USB-B plug to standard USB-A plug
- Available cordset lengths: 1m and 2m• For other lengths please contact us
- Rear mount Jam Nut receptacle with 50mm flying lead + 5-way connector back termination. Panel gasket included
- Temperature range: -20°C +80°C

Applications

- Embedded Computers
- Data Transfer
- Numerical Control Machine

Overmolded plug cordset : male sealed USB-B plug, standard USB-A plug.

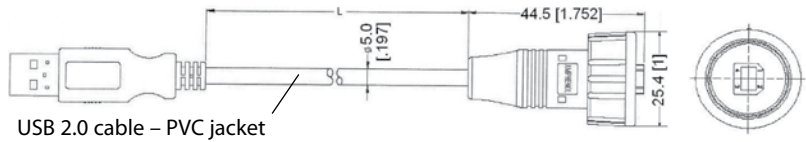

Part number	Length	
	USBBF6100	1000±50mm
USBBF6200	2000±50mm	[78.74±1.97]

Receptacle - Female USB-B



Part number :
USBBF7

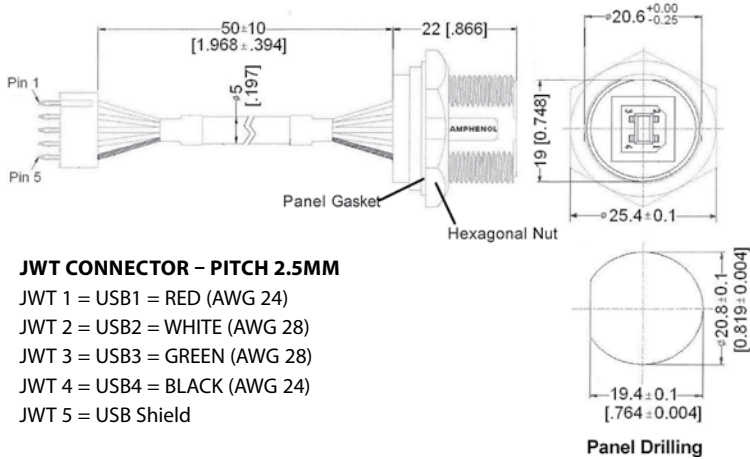

Receptacle cap



Part number:
USBBFC7

Rugged USB Solutions



Rugged electronics

Table of contents

NEW	Reinforced USB TV Memory Keys	102
	Reinforced USB Memory Keys	103
NEW	Reinforced USB amplifier	104



Reinforced USBF TV MEMORY KEYS

Derived from MIL-DTL-38999 series III specification • from 2 GB to 64 GB



We provide reinforced USB memory keys available in different capacities. They can be used ONLY with our USBF TV series receptacles. When mated on the receptacle, the system is IP68 and allows data transmission in harsh environments.

- Environmental Protection**
- Sealing: IP68 (when mated)
 - Salt Spray: 48 h with Nickel plating (ROHS)
> 500 h with Olive Drab Cadmium
 - Vibrations: MIL-STD-810F method 514.5 fig 514.5.C cat 14
 - Temperature Range: - 40°C / +85°C (MIL-STD-810F)
 - Data transmission during vibration & temperature tests

IMPORTANT NOTE
USBFTV memory key to be used with USBFTV receptacle, see page 72.

- Other features**
- Type: USB2.0 (capacities 2 GB & 4 GB)
USB3.0 (capacities 8 GB to 64 GB)
 - Voltage: 5V DC - 500 mA max
 - Electromagnetic compatibility: 89/336/EEC and Part 15 Class B

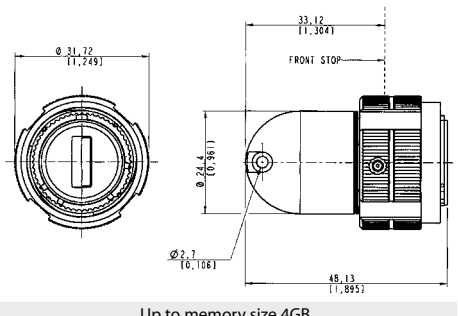

Up to memory size 4GB

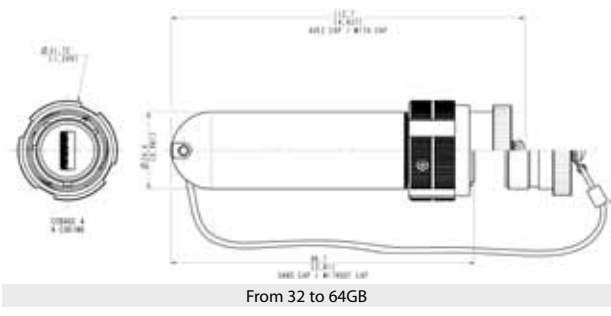

From 32 to 64GB

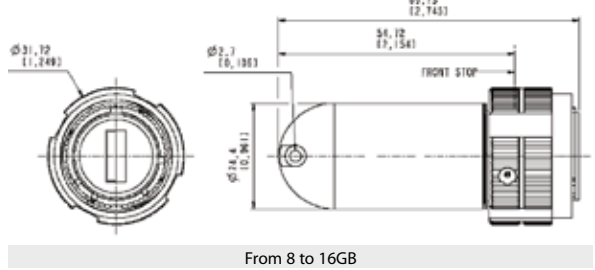

From 8 to 16GB

Note: Our rugged memory keys are sold under standard electronic manufacturer configuration. If, for your own usage, you need to re-configure the electronic (under Linux for example), it will be under customer responsibility. Amphenol is not responsible for any wrong doing or misguided use of the product by its customers. Under request, we can provide you with electronic manufacturer details so you can check if their specific configuration will work with the electronic (please specify memory capacity). Amphenol can also study the integration of electronic selected by a customer. In order to do so, we need to received a sample of the USB memory stick so we can study its integration into our existing concept or adapt it.

Please send your requests to contact@usbfield.com

USB cordset is included with each memory key

Definition of part number

USBFTV KEY 6	A	2048	N	CAP
USB3FTV KEY 6	CODING POSITION: A: coding A B: coding B	CAPACITY FOR USBFTV KEY: 2048 4096	PLATING: "N": Nickel plating "G": Olive Drab Cadmium	Cap: with cap Blank: without cap
Note: USB3.0 is compatible with USB2.0	*The coding can be changed on the receptacle counter part using our tool USBFODE	64GT CAPACITY FOR USB3FTV KEY: 8 16GT** 32GT** 64GT** Other capacity, please consult us at contact@usbfield.com	NB: please check the plating of your USBFTV receptacle	

** GT: Fast Data Transfer
EXAMPLE: **USBFTVKEY6A2048N**: USBFTV KEY – CODING A – CAPACITY OF 2048MB – NICKEL PLATING
EXAMPLE: **USB3FTVKEY6A64GTGAP**: USBFTV KEY – CODING A – CAPACITY OF 64GB – OLIVE DRAB CADMIUM PLATING - PROTECTIVE CAP
NB: PRODUCT SUGGESTED TO ELECTRONIC CHANGES DEPENDING ON OUR ELECTRONIC SUPPLIERS, NEW CAPACITIES, OBSOLESCENCE

Reinforced USB Memory Keys



We provide reinforced USB memory keys available in different capacities. When mated, the system is IP68. Shells are metallic with 1/4 turn bayonet coupling. It provides a full protection of the data stored into the keys when the cap is closed. For full data protection during data transfers, check our USBFTV memory keys.

Environmental Protection

- Sealing: IP68 (when closed)
- Salt Spray: 48 h with Nickel plating (ROHS)
> 96 h with Black coating (ROHS)
> 500 h with Olive Drab Cadmium
- Vibrations: MIL-STD-810F method 514.5 fig 514.5.C cat 14
- Temperature Range: - 40°C / +85°C (MIL-STD-810F)

Other features

- Type: USB2.0
- Voltage: 5V DC - 500 mA max
- Electromagnetic compatibility: 89/336/EEC and Part 15 Class B

IMPORTANT NOTE

Compatible with any standard USB port

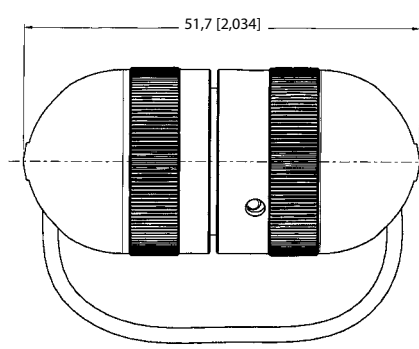

Up to memory size 8GB

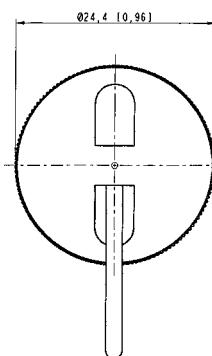

Note: Our rugged memory keys are sold under standard electronic manufacturer configuration. If, for your own usage, you need to re-configure the electronic (under Linux for example), it will be under customer responsibility.

Amphenol is not responsible for any wrong doing or misguided use of the product by its customers. Under request, we can provide you with electronic manufacturer details so you can check if their specific configuration will work with the electronic (please specify memory capacity).

Amphenol can also study the integration of electronic selected by a customer. In order to do so, we need to received a sample of the USB memory stick so we can study its integration into our existing concept or adapt it.

Please send your requests to contact@usbfield.com

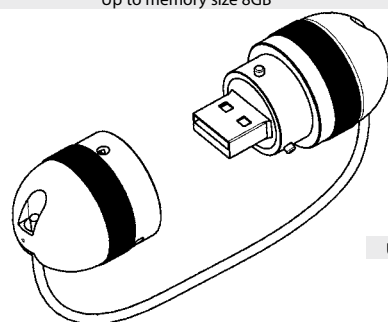

Rugged Metallic USB KEY with CAP SEALING: IP 67

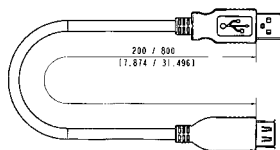

USB cordset is included with each memory key

DEFINITION OF PART NUMBER

USBF KEY

Beginning of every USB Key part number. Remains unchanged.

4096

Capacity of your USBF Key:
2048 | 4096 | 8192

Other capacity, please consult us at contact@rjfield.com

N

Shell finish:
N: Nickel
G: Green
B: Black

* GT: Fast Data Transfer

EXAMPLE: **USBFKEY4096N**: USB MEMORY KEY - CAPACITY OF 4096MB - SHELL FINISH: NICKEL

EXAMPLE: **USBFKEY2048G**: USB MEMORY KEY - CAPACITY OF 2048MB - SHELL FINISH: GREEN



Reinforced USB Amplifier

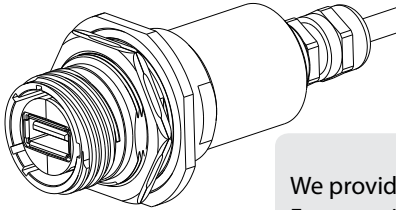

We provide USB amplifier if your need exceeds 5 meters up to 10 meters (16.40 up to 32.80 ft). For more information, please consult us.

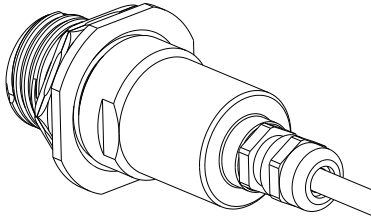

Jam nut receptacle Ampli with cable reinforced PU jacket open

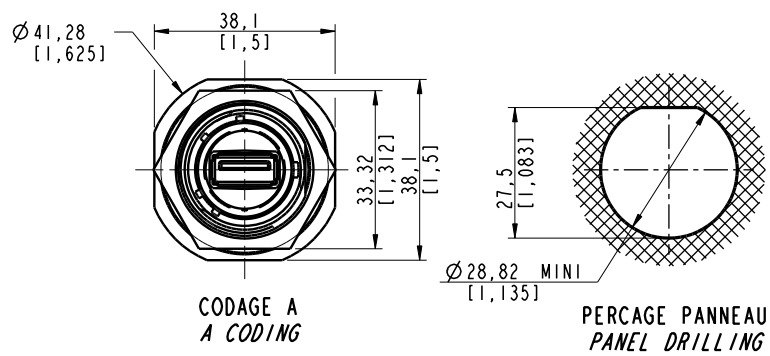
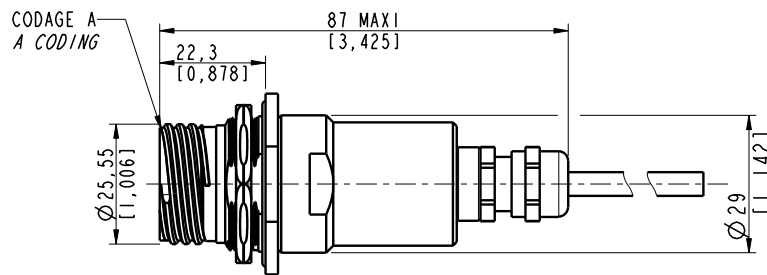



Rugged ATEX Zone 2 solutions



Table of contents

	RJFTVX, USBFTVX, RJ11FTVX	106
	RJSPCEX ATEX ZONE 2 Rugged & IP68 sealed Ethernet switch	112

RJFTVX, USBFTVX, RJ11FTVX

RJ45, USB, RJ11/12 explosion proof solutions for Zone 2



Amphenol Atex Field Bus range is designed for device group II category 3G. According to EN60079-15 it may be operated within zone 2 and class I, Division 2, as low power non sparking connectors.



RJFTVX • Rugged and sealed RJ45 connector



RJFTVX allows you to use an Ethernet Class D / Cat. 5e connection for 10 BaseT, 100 BaseTx or 1000 BaseT networks in ATEX zone 2 environments. With the patented RJStop system you can use a standard RJ45 cordset in a metallic plug which will protect it from shocks, dust and fluids. RJFTVX features the same main characteristics than RJFTV series (see page 24).

Plug

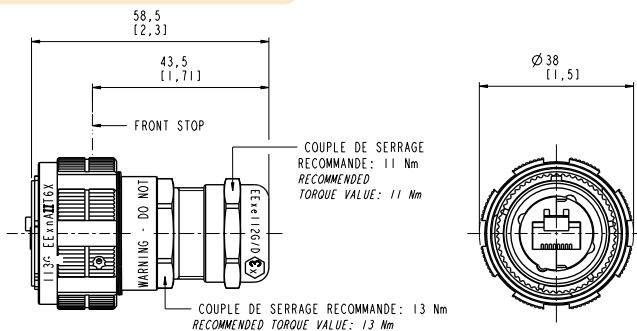

Characteristics

- Ex marking: IIG ExnAII6 X
- Operating temperature range: -40°C / +60°C
- Voltage: 60 Veff max
- Power: 20 W max
- Outside cable diameter: 6mm to 12mm
- Sealing: IP68
- Data transmission: 10 BaseT, 100 BaseTX & 1000 BaseT networks. Cat. 5e per TIA/EIA 568B & Class D per ISO/IEC 11801

Part number	Plug	Nickel plating	Olive drab cadmium plating
		RJFTVX6MN	RJFTVX6MG
	IP68 metallic cap	RJFTVC6N	RJFTVC6G

Square flange receptacle

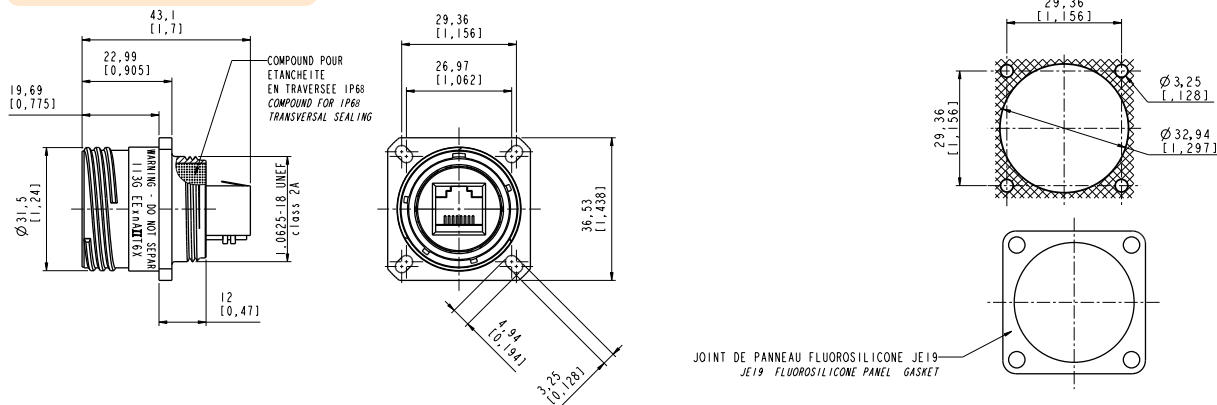

Part number	Receptacle, RJ45 back termination, coding A	Nickel plating	Olive drab cadmium plating
		RJFTVX2SA1N	RJFTVX2SA1G
	Receptacle cap	RJFTVC2N	RJFTVC2G



Jam nut receptacle

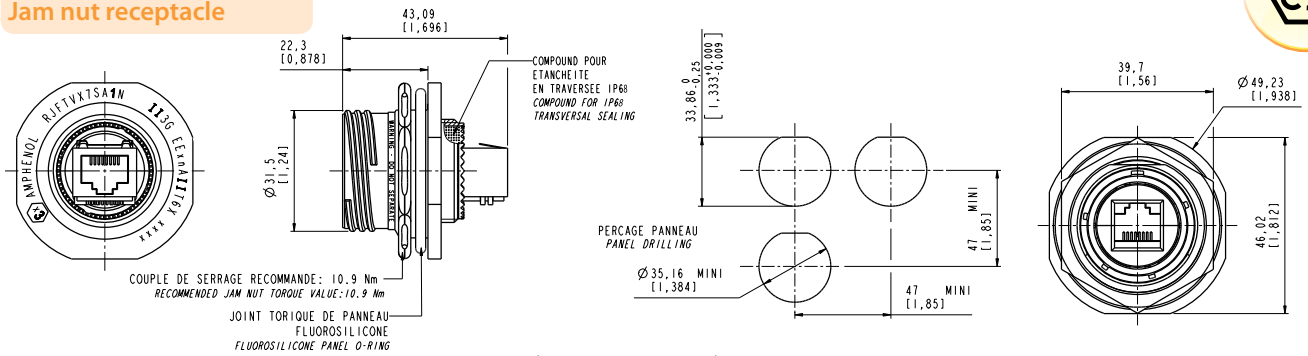

		Nickel plating	Olive drab cadmium plating
Part number	Receptacle, RJ45 back termination, coding A	RJFTVX7SA1N	RJFTVX7SA1G
	IP68 metallic cap	RJFTVC7N	RJFTVC7G

REMARK: As receptacles are compounded (IP68 transversally sealing), coding position has to be specified in the part number : A (standard), B, C or D

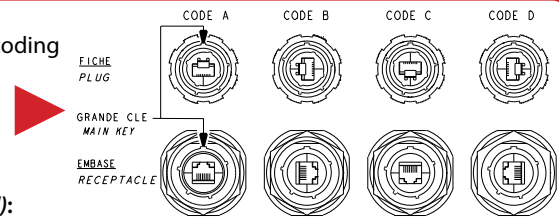

Receptacles can be provided with RJ45 cordsets.

There are 4 standard lengths as described hereunder (with coding "A"):

Part number	Nickel plating	Olive drab cadmium plating	RJ45 cordset length Meters
	RJFTVX2SA2N03100BTX	RJFTVX2SA2G03100BTX	0.3
	RJFTVX2SA2N05100BTX	RJFTVX2SA2G05100BTX	0.5
	RJFTVX2SA2N10100BTX	RJFTVX2SA2G10100BTX	1.0
	RJFTVX2SA2N15100BTX	RJFTVX2SA2G15100BTX	1.5

Part number code

Series	RJ Field TV	RJFTVX	75	A	2	N	05 100BTX
Shell Type	25 : Square flange receptacle 75: Jam nut receptacle 6 : Plug						
Coding	"A" (Standard) or "B", "C", "D"						
Back Terminations (for receptacles only)	1: Female RJ45 2: RJ45 cordset						
Shell Material and Finish	N: Nickel G: Olive drab cadmium						
Cordset length (for receptacles with "2" back termination only)	03 100BTX: 30 cm [11.81 inches] 05 100 BTX: 50 cm [19.68 inches] 10 100 BTX: 1 meter [39.37 inches] 15 100BTX: 1,5 meters [59.04 inches]						



USBFTVX • Rugged and sealed USB connector



With USBFTVX, you can insert a standard USB 2.0 cordset into a metallic plug which will protect it from shocks, dust and fluids. This range is fitted to be used in Atex zone 2 environments. This metallic plug is connected into a receptacle, using a Tri Start thread coupling mechanism (MIL-DTL-38999 series III type) with anti-decoupling device for high vibrations. USBFTVX features the same main characteristics than USBFTV series (see page 72).

Characteristics	
■ Ex marking	II3G ExnAII6 X
■ Operating temperature range	-40°C / +70°C
■ Voltage	60 Veff max
■ Power	20 W max
■ Outside cable diameter	4mm to 6mm
■ Sealing	IP68
■ Data transmission	USB 2.0 up to 480 Mb/s

Plug

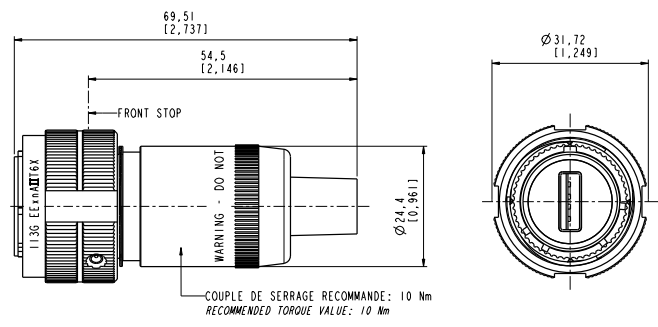

Part number	Plug	Nickel plating	Olive drab cadmium plating
		USBFTVX6N	USBFTVX6G
IP68 metallic cap	USBFTVC6N	USBFTVC6G	

Square flange receptacle

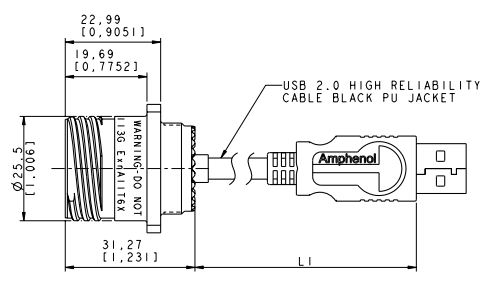

Cable end Type "A" (Standard USB "A" Plug)

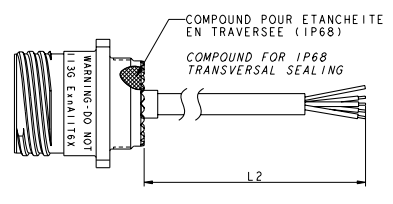

Cable end Type "OPEN" (No connector)

Jam nut receptacle

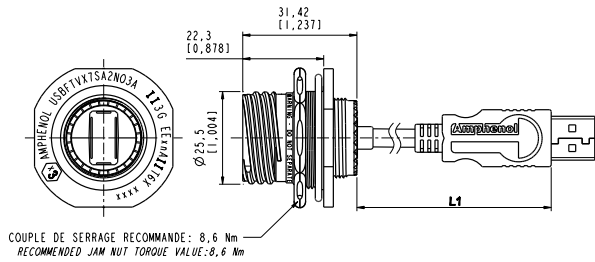

Cable end Type "A" (Standard USB "A" Plug)

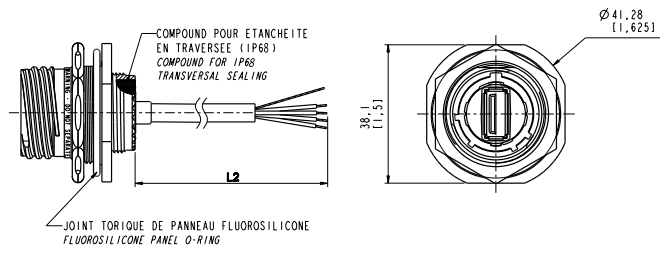

Cable end Type "OPEN" (No connector)

Part number code

Series	USBF TVX	2S	A	2	N	03	A
USB Field TV							
Shell Type							
2S :	Square flange receptacle						
7S :	Jam nut receptacle						
Coding							
"A" (Standard) or "B"							
Back Terminations							
2:	Rugged USB cable						
Shells Plating							
N:	Nickel						
G:	Olive drab cadmium plating						
USB cable length							
03:	30 cm [11.81 inches]						
05:	50 cm [19.68 inches]						
10:	1 meter [39.37 inches]						
USB cable end							
A:	Standard USB-A plug						
OPEN:	Open cable (no connector)						

CAPS for receptacles :

		Nickel plating	Olive drab cadmium plating
Part number FOR	Cap for Square flange receptacle	USBFTVC2N	USBFTVC2G
	Cap for Jam nut receptacle	USBFTVC7N	USBFTVC7G



RJ11FTVX • Rugged and sealed RJ11/12 connector



RJ11FTVX allows you to use a standard phone RJ11/RJ12 connection in Atex zone 2 environments.

With the patented RJStop® system you can use a standard RJ11 / RJ12 cordset in a metallic plug which will protect it from shocks, dust and fluids.

Characteristics

■ Ex marking	II3G ExnAII T6 X
■ Operating temperature range	-40°C / +60°C
■ Voltage	60 Veff max
■ Power	20 W max
■ Outside cable diameter	4mm to 5.5mm
■ Sealing	IP68
■ Coupling mechanism	Tri Star thread with anti-decoupling device (MIL-DTL-38999 series III)
■ Mating cycles	500 min
■ Salt spray	48h with nickel plating / 500 h with olive drab cadmium plating
■ Coding	4 mechanical user-defined coding / Polarization settings (insert rotation)
■ Fire retardant / Low smoke	UL94 V0 and NF16 101 & 16 102
■ R11 cordset retention in the plug	100 N in the Axis

Plug

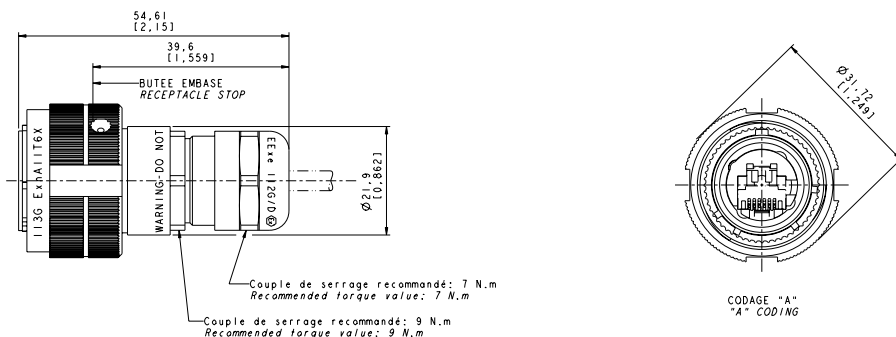

Part number	Nickel plating		Olive drab cadmium plating	
	Plug	RJ11FTVX6MN	RJ11FTVX6MG	
Cap	RJ11FTVC6N	RJ11FTVC6G		

Square flange receptacle

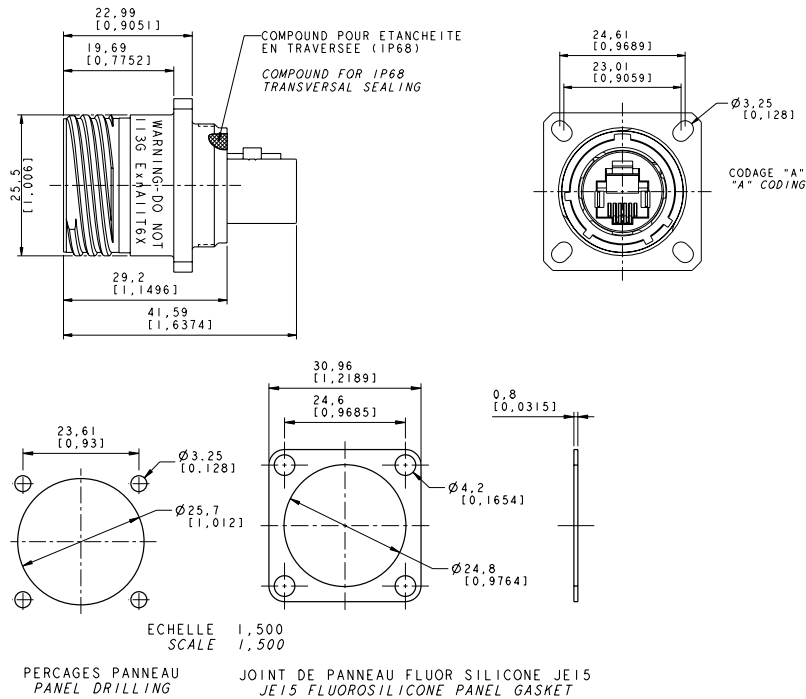

	Nickel plating	Olive drab cadmium plating
Part number Receptacle - Female RJ11 back termination - Coding A	RJ11FTVX2SA1N	RJ11FTVX2SA1G
Receptacle CAP	RJ11FTVC2N	RJ11FTVC2G

Jam nut receptacle

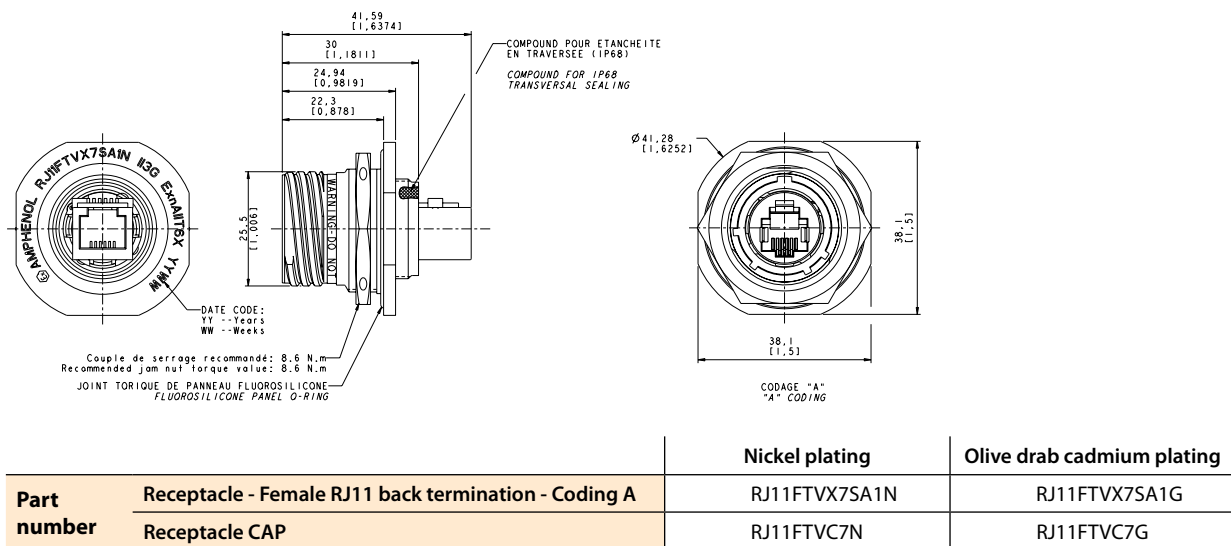

	Nickel plating	Olive drab cadmium plating
Part number Receptacle - Female RJ11 back termination - Coding A	RJ11FTVX7SA1N	RJ11FTVX7SA1G
Receptacle CAP	RJ11FTVC7N	RJ11FTVC7G

REMARK: As receptacles are compounded (IP68 transversally sealing), coding position has to be specified in the part number : A (standard), B, C or D (connection side views)

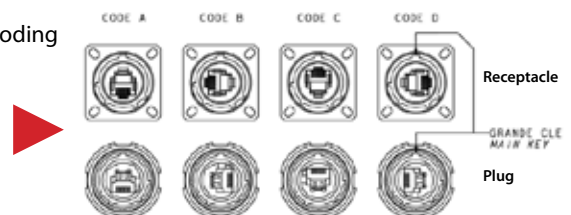

RJSPCEX ATEX ZONE 2 RUGGED & IP68

Sealed ethernet switch



This Ethernet Switch is a combination of rugged packaging with locking device for Zone 2 hazardous location, with fault-tolerant network redundancy.

Industrial Applications

- Oil & Gas
- Process Control
- Factory Automation

P/N: RJSPC-EX-5ES1-PLG-CAPS

Note: this part number includes:

- One ATEX Zone 2 IP68 Plug and Play Ethernet switch equipped with caps on Ethernet connectors
- One power plug equipped with anti decoupling nut
- Five Ethernet plugs equipped with anti decoupling spring

P/N: RJSPC-EX-5RS1-PLG-CAPS

Note: this part number includes:

- One ATEX Zone 2 IP68 RING Ethernet switch equipped with caps on Ethernet connectors
- One power plug equipped with anti decoupling nut
- Five Ethernet plugs equipped with anti decoupling spring

Outstanding features

- IP65/68 Sealing
- ATEX Zone 2II3G ExnAII T4X (EN60079-15 & EN60079-0)
- Plug and Play simplicity
- Ring redundancy
- Operating temperature: -40°F to 170°F (-40°C to +75°C)

Key Features

- Ring Switch Networking Features (managed features available!)
 - Real-Time Ring for ultra-fast fault-tolerant loops
 - Recovery time of 30 ms + 5 ms per hop!
 - Modbus monitoring over Ethernet
 - Ideal for deterministic systems and PLCs
 - Real-time traffic prioritization (QoS and CoS)
 - Assure delivery of real-time data
 - Improve network utilization
 - User settable priority assignments
 - Advanced switch features
 - User configurable port settings
 - Port mirroring for traffic diagnostics
 - Pre-configurable for Plug-And-Play simplicity

Description (example for Ring model)

- Waterproof IP68 Rating (NEMA 6)
- Reduced Installation Costs with the patented RJStop® system
- Use any standard RJ45 cordset
- Rugged Enclosure in Polyester reinforced with 30% glass fiber
- Redundant power inputs with surge/spike protection
- Ultra reliable 1,000,000 hours Mean Time Between Failure (MTBF)
- Zone 2 hazardous location (models RJSPC-EX)



- 1 LEDs indicating activity, link status, datarate (10/100 Mbps)
- 2 LED indicating ring status
- 3 5 rugged IP68 RJ Field Ethernet ports
- 4 Real-time ring feature
- 5 IP68 polyester enclosure reinforced with glass fiber
- 6 OK power & ring status
- 7 LEDs indicating power
- 8 Anti-decoupling nut for power plug
- 9 Anti-decoupling spring for ethernet plugs

Other rugged solutions



Field installable

Table of contents

FWFTV	114
Self Closing Cap for IEEE1394 receptacles	117
RJ11F	118
NEW Special RJ11 Military & Commercial Aeronautics	120
MTRJF TV	122
LC Field	124

FWF TV

IEEE 1394A Connection System for Harsh Environments



With FW Field, you can insert a standard IEEE1394A cordset into a metallic plug which will protect it from shocks, dust and fluids.

No hazardous on-field cabling and grounding!

This metallic plug is connected into a receptacle, using a Tri Start Thread coupling mechanism (MIL-DTL-38999 series III type) with anti-decoupling device for high vibrations.

Applications

- Embedded Computers
- Video
- Railways
- Battelfield Communication Systems
- Naval & Shipboard Systems
- Robotics & Automation
- Process Control
- Rugged Communications

Main characteristics

- No assembly tools required
- Sealed against fluids and dusts (IP68)
- No time-consuming in-field cabling operation necessary
- **Tri-start thread coupling mechanism (MIL-DTL-38999 series III type) with anti-decoupling device**
- FW plug retention in the receptacle: 100 N in the axis
- Mating cycles: 500 minimum
- Improved EMI protection

Environmental Protection

- Sealing (mated): IP68 (Temporary immersion - 1 meter up to 30 minutes)
- Salt Spray: 48 h with Nickel plating
> 500 h with Olive Drab Cadmium
- Fire Retardant / Low Smoke: UL94 V0 and NF F 16 101 & 16 102
- Vibrations: 10 – 500 Hz, 10 g, 3 axes: no discontinuity > 1micro s
- Shocks: IK06: weight of 250 g drop from 40 cm [15.75 in] onto connectors (mated pair)
- Humidity: 21 days, 43°C, 98% humidity
- Temperature Range: - 40°C / +85°C

Data Transmission

IEEE 1394a-2000
400 Mbits/second over 4.5 meters

Part Number Code

Series	FWF TV	2	1	G
IEEE1394 Field TV				
Shell Type				
6:	Plug			
2:	Square Flange Receptacle			
2PE:	Square flange receptacle with metal backshell (type 1) & with metal backshell + plastic gland (type 2)			
7:	Jam Nut Receptacle			
7PE:	Jam nut receptacle with metal backshell (type 1) & with metal backshell + plastic gland (type 2)			
Back Terminations (Receptacles only)				
1:	IEEE 1394 receptacle			
2:	Solder Board (6 tinned holes)			
Shell Plating				
N:	Nickel - ROHS Compliant			
G:	Olive Drab Cadmium			

- Examples:
- Olive Drab Cadmium Plug: FWF TV 6G
 - Olive Drab Cadmium Square Flange Receptacle, IEEE 1394 front & back: FWF TV 21G
 - Olive Drab Cadmium Jam Nut Receptacle, IEEE 1394 front and back: FWF TV 71G
 - Nickel Jam Nut Receptacle, solder board termination: FWF TV 72N

Plug

- Shell type 6

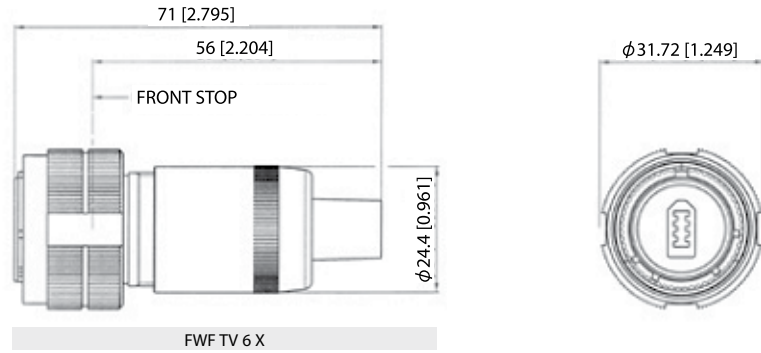

Receptacles

- Square flange receptacle
4 mounting holes: Shell type 2

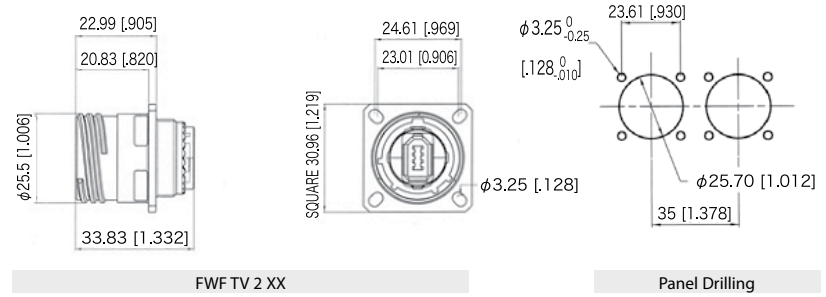

- Jam nut receptacle
Hexagonal Nut mounting: Shell type 7

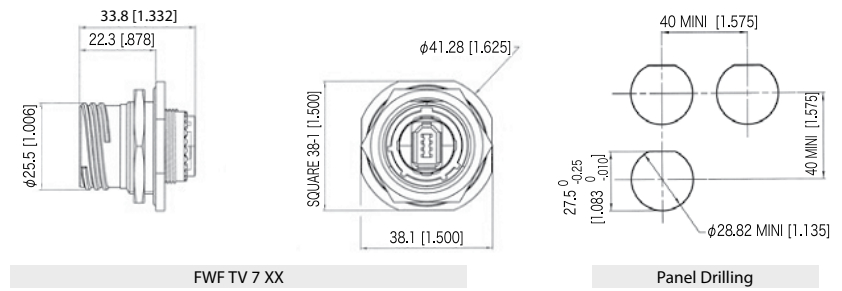

- Receptacles with backshell:
Shell type 2PE and 7PE

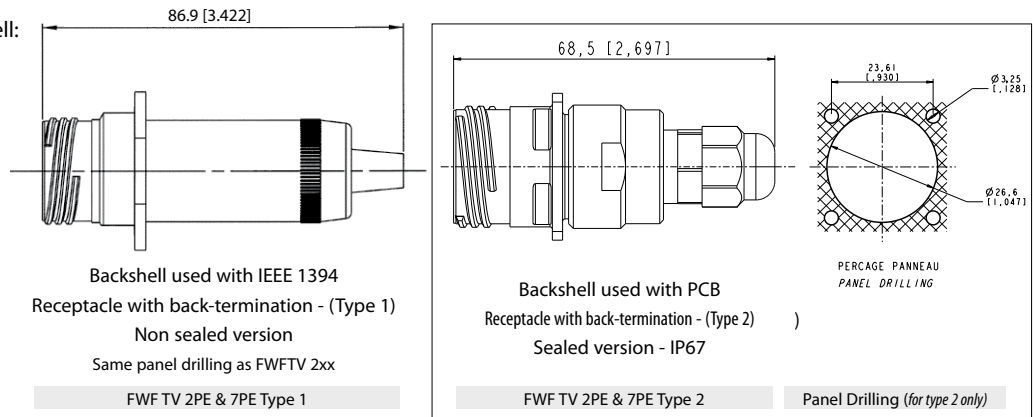

Back Terminations

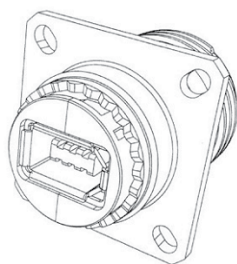

Type 1: IEEE 1394 Receptacle

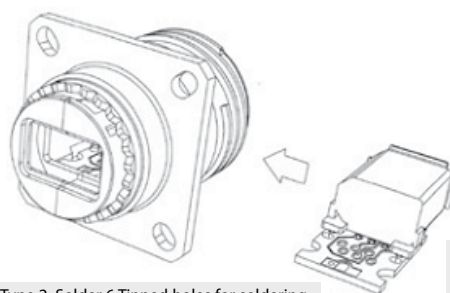

Type 2: Solder 6 Tinned holes for soldering

View of the PCB Type 2 version - with 6 tinned holes for solder termination

Assembly Instructions

Can be used with most IEEE 1394 cordset brands: No tools required!

Plug Assembly

1. If a fully sealed (IP68) assembly is required: Install the white tape around the plug to cover the 4 holes of the overmolding. If there are no holes omit this step.
2. Insert the black O Ring around the front face of the IEEE 1394 plug. This O Ring will ensure the seal.
3. Insert the IEEE 1394 cordset into the metallic backshell.
4. Insert the retention spacer laterally onto the cable (this spacer is soft so as to adapt to various overmolding styles) and slide the IEEE 1394 plug into this retention spacer.
5. Insert the friction ring laterally onto the cable cordset.
6. Insert the IEEE 1394 plug into the metallic circular shell. Note at this step that the main key is used for polarization.
7. Screw the backshell on the plug body. A spanner may be required to fully close the backshell to the circular shell.

Important Note: The sealing of the connector is not done by the black retention spacers which are slotted, but rather by the front face O-Ring (Fig 2).

Receptacle Assembly

To Solder your cable onto the PCB:

1. Attach the 2 metallized plastic inserts around the PCB (Fig 1a & 1b).
2. Insert the IEEE 1394 module from the rear of the connector.

Removing Modules

1. Insert the removal tool FWF ODE from the front
2. Push the module back with thumb.

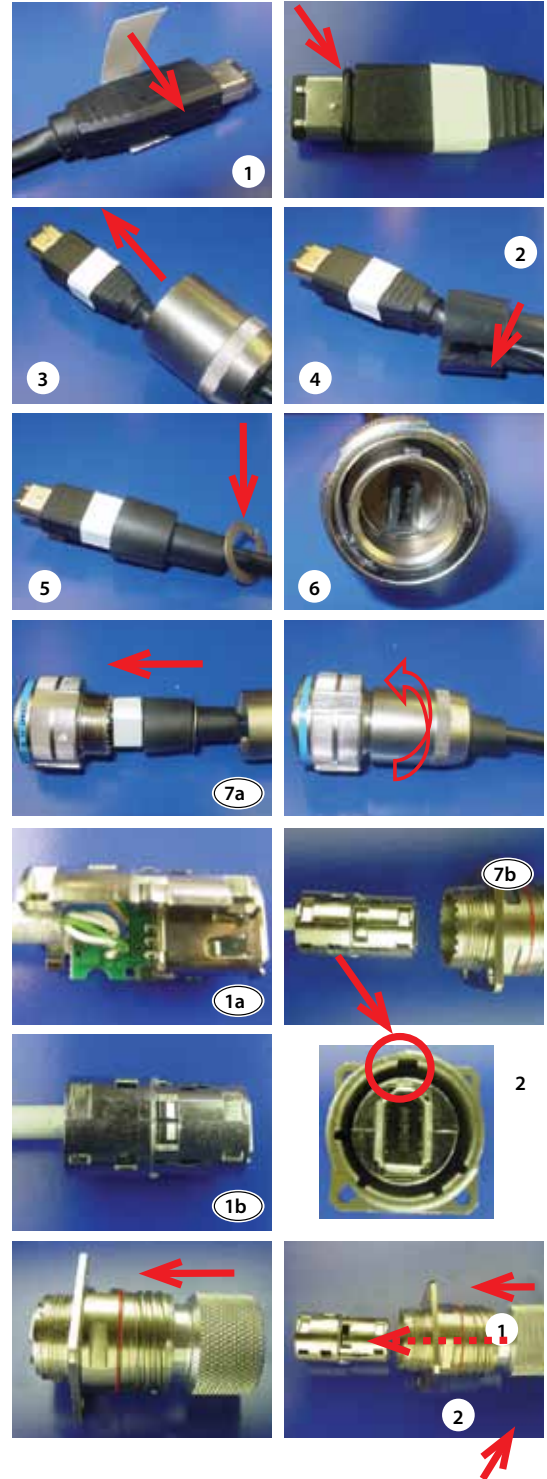

Accessories

Metallic Caps

	FWF TVC	2	G
Connector Type			
6:	Plug		
2:	Square Flange Receptacle		
7:	Jam Nut Receptacle		
Shell plating			
N:	Nickel - ROHS Compliant		
G:	Olive Drab Cadmium		

- Panel Gasket for square flange receptacle (Thickness: 0,8 mm [.031]): JE15



- Receptacle Insert removal tool: FWF ODE

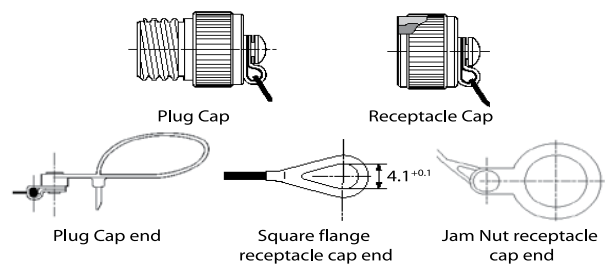

SELF CLOSING CAP

For IEEE1394 Receptacles



This Self Closing Cap automatically protects the RJ Field square flange receptacles (MIL-C-26482 type), protecting your system from dust and water projections. The same cap can be used to protect USB and IEEE1394 receptacles. A spring automatically closes the upper part of the cap when either the RJ Field plug, RJ45 cordset, USB or IEEE1394 cordset, or USB key are removed from the receptacle.

FWF 21 X SCC

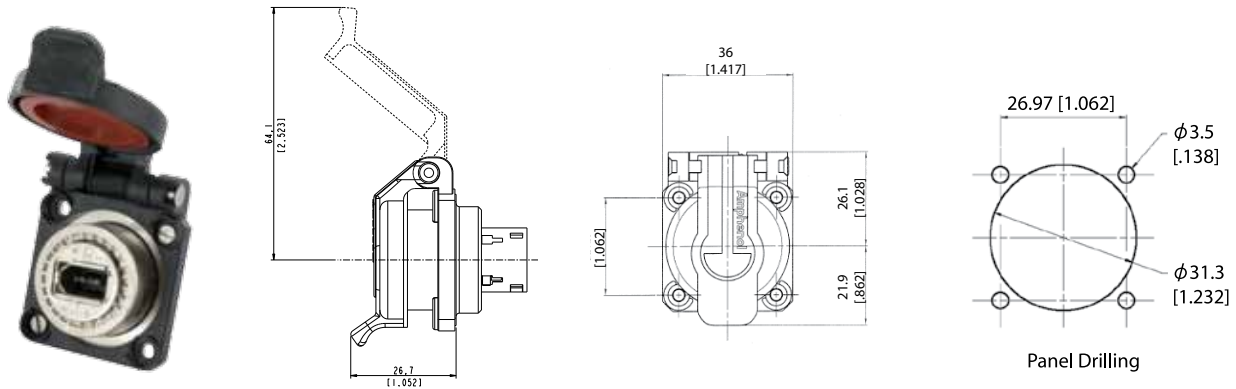

Version IEEE1394

Part number *	Plating		Metallized inserts (EMI)	
	FWF 21B SCC	Black coated	No (blank insert)	
FWF 21N SCC	Nickel plated		Yes	
FWF 21G SCC	Olive drab cadmium plated		Yes	

* The part number includes the receptacle + the self closing cap

■ **Note:** Panel gasket with any of these receptacles: JE18



RJF 21 X SCC, USBF 21 X SCC, USBBF 21 X SCC



RJ45 version

(see page 23)



USB-A version

(see page 83)



USB-B version

(see page 92)

RJ11F

Rugged RJ11/RJ12 Connection System for Harsh Environment



RJ11Field allows you to use a standard phone RJ11 / RJ12 connection in harsh environments. With the patented RJStop® system you can use a standard RJ11 / RJ12 cordset in a metallic plug which will protect it from shocks, dust and fluids. No hazardous on-field cabling!

Applications

- Industrial applications
- Battlefield communication

Main characteristics

- Bayonet coupling ("Audible & Visual" coupling signal)
- Robust metallic shells based on MIL-DTL-26482 H
- 4 mechanical user-defined coding / Polarization settings (insert rotation)
- RJ11 cordset retention in the plug: 100 N in the axis
- Mating cycles: 500 min

Environmental Protection

- Sealing: IP68
- Salt Spray: 48 h with Nickel plating
> 96 h with black coating
> 500 h with Oliv Drab Cadmium
- Fire Retardant / Low Smoke: UL94 V0 and NF F 16 101 & 16 102
- Vibrations: 10 – 500 Hz, 10 g, 3 axes: no discontinuity > 10 nano s.
- Shocks: IK06: weight of 250 g drop from 40 cm [15.75 in] onto connectors (*mated pair*)
- Humidity: 21 days, 43°C, 98% humidity
- Thermal Shock: 5 cycles at - 40°C / +100°C
- Temperature Range: - 40°C / +85°C

Part Number Code

Series	RJ11F	2	2	B
RJ11Field				
Shell Type				
6: Plug, Plastic Gland				
2: Square Flange Receptacle				
7: Jam Nut Receptacle				
Back Terminations (For Receptacles only)				
1: Female RJ11				
2: Solder (6 tinned holes)				
Shell Finishes				
B: Black Coating - ROHS Compliant				
N: Nickel - ROHS Compliant				
G: Olive Drab Cadmium				

- Examples:
- Black Plug: RJ11F 6 B
 - Black square flange receptacle, Female RJ11 Back termination: RJ11F 2 1 B
 - Nickel Jam Nut Receptacle, solder termination: RJ11F 72 N

■ Metallic cap

	RJ11FC	2	B
Connector Type			
6: Plug			
2: Square Flange Receptacle			
7: Jam Nut Receptacle			
Finishes			
B: Black Coating - ROHS Compliant			
N: Nickel - ROHS Compliant			
G: Olive Drab Cadmium			

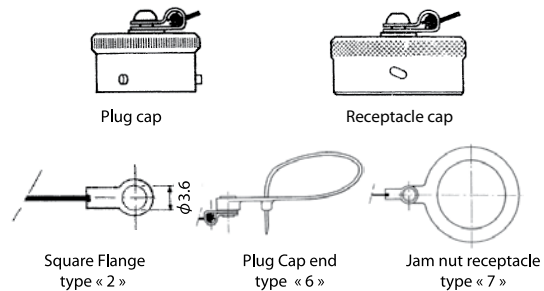

- Panel gasket for square flange « 2 » thickness: 0,6 mm
P/N: JE 14



- Insert removal tool for receptacle and plug
P/N = RJ11F ODE



Plug

■ Shell type 6 with Plastic Gland

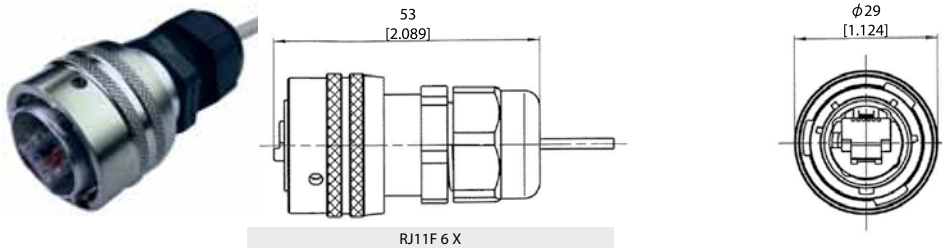

Receptacles

■ Square flange receptacle, 4 mounting holes: shell type 2

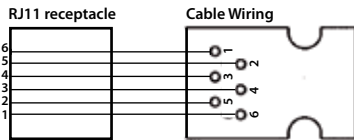
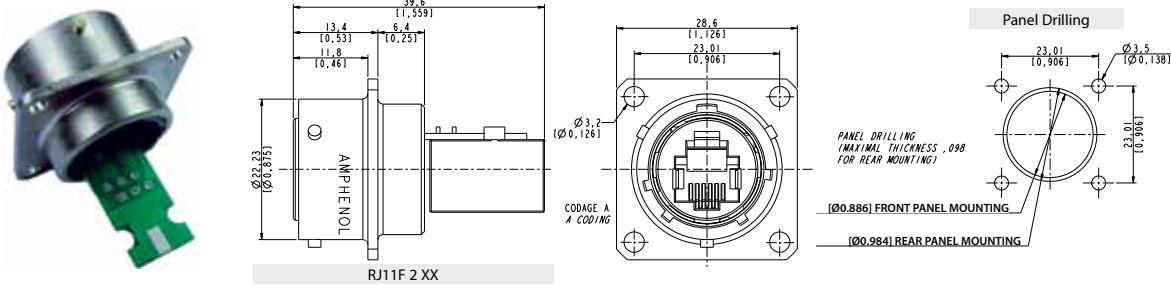

■ Jam nut receptacle, Hexagonal Nut mounting: Shell type 7

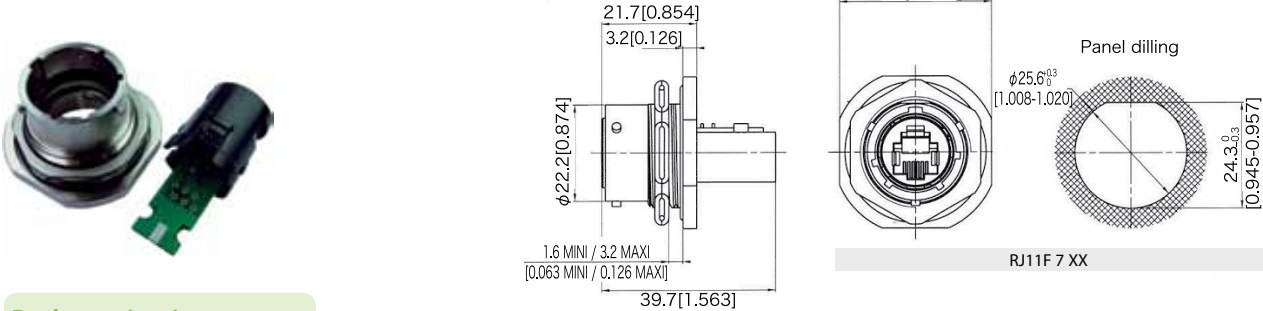

Back terminations

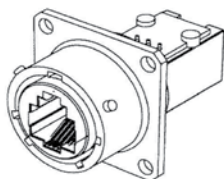

Type 1: Female RJ11 / RJ12

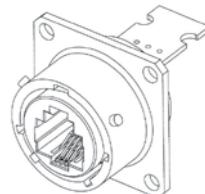

Type 2: Solder 6 Tinned through holes to solder your cable

Assembly instructions

Easy and Safe: No field cabling tools required

1. Pass the RJ11 / RJ12 plug through the plastic gland
2. Laterally slide the insert on the cable
3. Fix the RJ11 / RJ12 plug in the insert, pushing on the lever
4. Insert in the metallic housing
5. Tighten the plastic gland

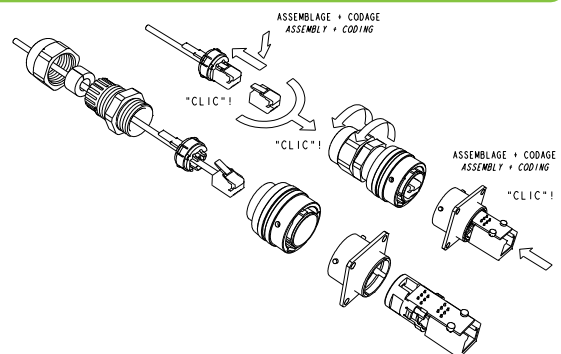
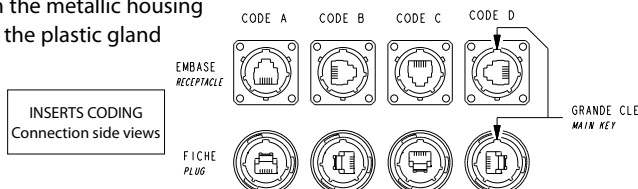



Special RJ11 adaptor

For Military & Commercial Aeronautics

RJ11 adaptor only

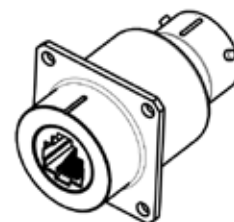
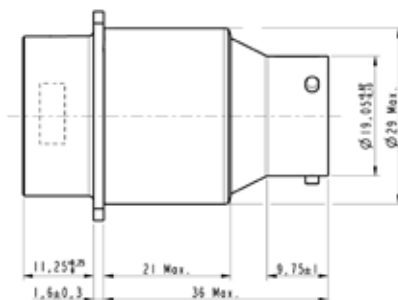

Part number	Coding	
	35639	Y
35641	W	
35643	Z	
35645	N	

RJ11 adaptor + Self Closing Cap

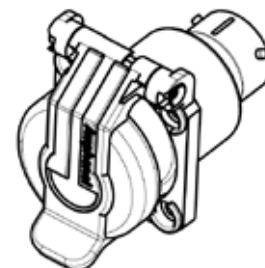
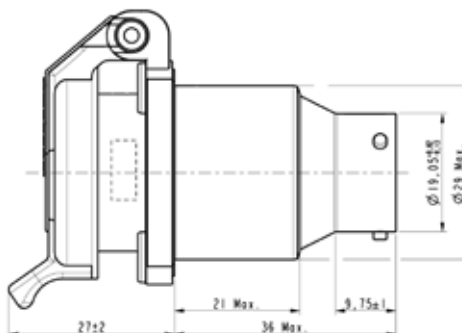

Part number	Coding	
	35623	N
35640	Y	
35642	W	
35644	Z	

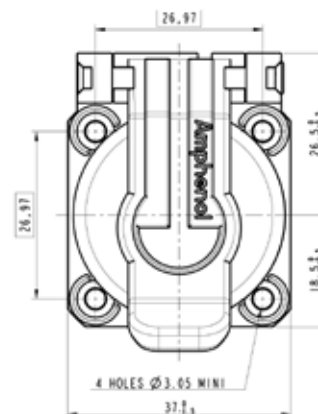
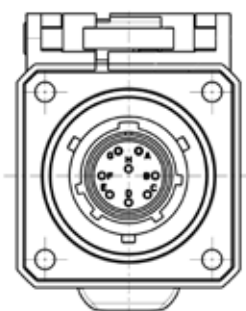

For all options:

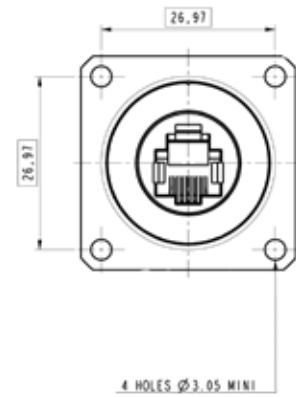
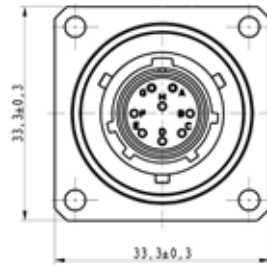
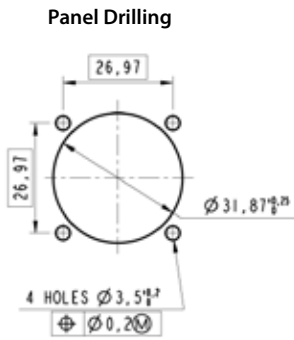

12-8 Male contact / EN3155

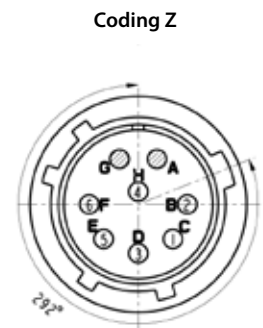
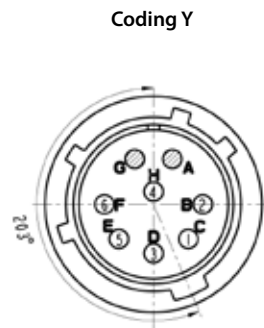
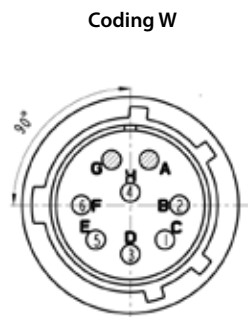
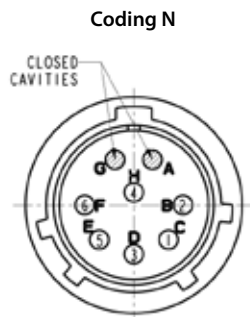

MTRJF TV

Transform your MTRJ patchcord into an Environmental Connector



With MTRJFTV you can use a standard MTRJ patchcord in a **metallic** plug which will protect it from shocks, dust and fluids.

No hazardous on-field cabling!

The MTRJ Field offers an easy system to upgrade from a standard to an environmental MTRJ.

- Sealed against fluids and dust (IP68)
- Shock, Vibration proof,
- No cabling operation in field and no tools required for installation

Applications

- Railways
- Base Station
- Military communication
- Navy

Mechanical characteristics

- Number of Channels: 2
- Typical Insertion Loss: 0,5dB in MM
- Durability: 500 mating/unmating cycles (changes for <0,2 dB)

Part Number Code

Serie	MTRJF TV	6M	C	G	N
MTRJ Field TV					
Shell Type					
6:	Plug with metal backshell, plastic PG clamp				
6M:	Plug with metal backshell and metal PG clamp				
2:	Square flange receptacle				
2PE:	Square flange, metal backshell and plastic PG clamp				
2PEM:	Square flange, metal backshell and metal PG clamp				
7:	Jam nut receptacle				
7PE:	Jam nut, metal backshell and plastic PG clamp				
7PEM:	Jam nut, metal backshell and metal PG clamp				
Cable Type					
Only for receptacle					
0:	Receptacle without backshell				
Only for plug					
C:	Mini round cable 2,8 mm				
D:	Flat duplex cable 1,6 mm				
S:	Duplex zipcord 1,6 mm				
T:	Flat duplex cable + Duplex zipcord for 1,6 mm - 2mm - 2,8mm				
Shell Finish					
N:	Nickel plated				
G:	Olive drab cadmium plated				
B:	Bronze				
D:	Black zinc cobalt				
Z:	Olive drab zinc cobalt				
Polarization					
N:	Normal				
A / B / C / D / E					

Cap Series	B	EC	N	TV	W	13
Protective cap type						
EC:	For square flange receptacle					
ER:	For jam nut receptacle					
F:	For plug					
Wire type						
N:	Nylon cord					
Blank:	Metallic chain					
TV:	Series					
Shell finish						
B:	Bronze					
F:	Electroless nickel plated, aluminium version					
W:	Olive drab cadmium plated, aluminium version					
D:	Black zinc cobalt					
Z:	Olive drab zinc cobalt					

Requested information to order MTRJ Field Patchcord

Plug MTRJ: Male /Female
 Type of fiber: 50/125, 62,5/125, 9/125
 Patchcord length: ex 10.5m
 Drawing: description of the product

Contact us for other configuration

Dismounting Tool Ordering Information

MTRJFTV DM TOOL

Line drawings (Dimensions in mm)

■ Plug (MIL DTL 38 999 series III Size 13)

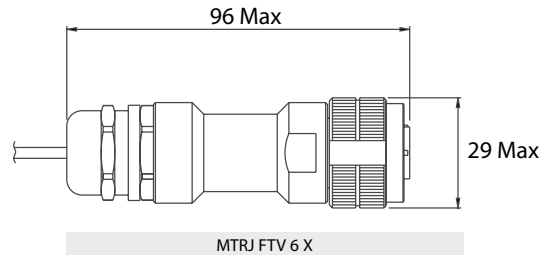

■ Receptacle (MIL DTL 38 999 series III Size 13) with backshell

Jam Nut receptacle with backshell

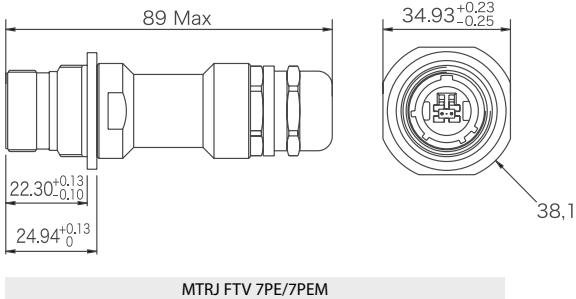

Square flange receptacle with backshell

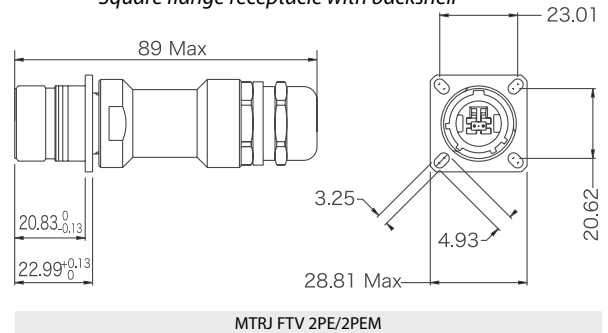

■ Square Flange Receptacle (MIL DTL 38 999 series III Size 13)

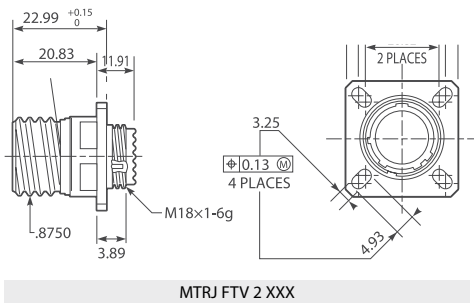

Square flange receptacle rear panel mounting

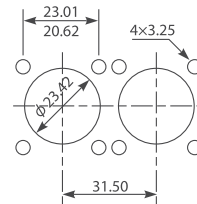

Square flange receptacle front panel mounting

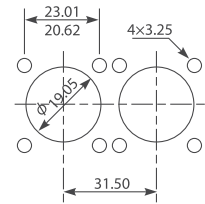

Panel Drilling

■ Jam Nut Receptacle (MIL DTL 38 999 series III Size 13)

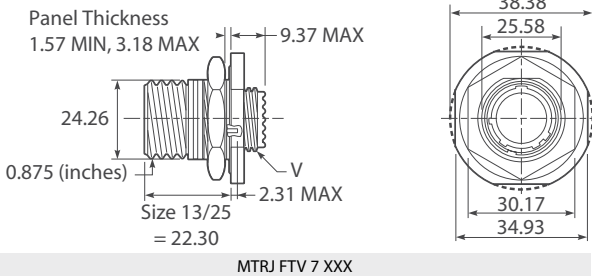

Jam nut receptacle rear panel mounting

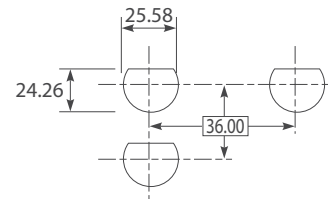

Panel Drilling

Protective caps

Protective cap for plug (nylon cord)

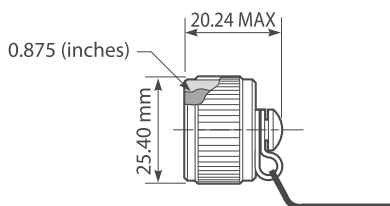

Protective cap for receptacles (nylon cord)

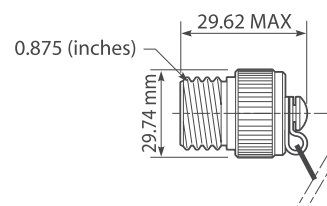

LC FIELD

Transform your LC patchcord into an Environmental Connector



The LC Field offers an easy system to upgrade from a standard to an environmental LC.

- Sealed against fluids and dust (IP68)
- Shock, Vibration proof
- No cabling operation in field and no tools required for installation (except 1,6mm and 2mm zipcord cable)

With the patented RJStop® system you can use a standard LC patchcord in a metallic plug which will protect it from shocks, dust and fluids.

No hazardous on-field cabling!

Applications

- Railways
- Base Station
- Military communication
- Navy

Mechanical characteristics

- Number of Channels: 2
- Typical Insertion Loss: 0,5dB in MM and SM
- Durability 500 mating/unmating cycles (changes for <0,2 dB)

Part Number Code

Serie	LCFTV	6M	D	G	N
Optical connector type					
Shell Type					
6M:	Plug with metal backshell and metal PG clamp				
2:	Square flange receptacle without backshell				
7:	Jam nut receptacle without backshell				
Cable Type					
Only for plug					
D:	Flat duplex cable 1,6 mm				
E:	Duplex zipcord 1,6 mm				
F:	Flat duplex cable 2 mm				
G:	Duplex zipcord 2 mm				
H:	Flat duplex cable 2,8 mm				
I:	Duplex zipcord 2,8 mm				
T:	Flat duplex cable + Duplex zipcord for 1,6 mm - 2 mm - 2,8 mm				
Only for receptacle (no backshell available for receptacle)					
0:	Receptacle without backshell				
Shell Finish					
N:	Nickel plated				
G:	Olive drab cadmium plated				
B:	Bronze				
D:	Black zinc cobalt				
Z:	Olive drab zinc cobalt				
Polarization					
N:	Normal				
A / B / C / D / E					

Cap Series	B	EC	N	TV	W	19
Protective cap type						
EC:		For square flange receptacle				
ER:		For jam nut receptacle				
F:		For plug				
Wire type						
N:		Nylon cord				
Blank:		Metallic chain				
TV:		Series				
Shell finish						
B:		Bronze				
F:		Electroless nickel plated, aluminium version				
W:		Olive drab cadmium plated, aluminium version				
D:		Black zinc cobalt				
Z:		Olive drab zinc cobalt				
Corresponding connector shell size: 19						

Requested information to order LC Field Patchcord

Type of connector: Male /Female
 Type of fiber: 50/125, 62,5/125, 9/125
 Patchcord length: ex 10.5m
 Drawing: description of the product
 Contact us for other configuration.

Tools informations

Mounting Tools:
 LCFTV MO TOOL: LC FIELD Mounting tools

Dismounting Tools:
 LCFTV DM TOOL: LC FIELD Dismounting tools
 (To dismount the LC you need to use both dismounting and mounting tools)

Line drawings (Dimensions in mm)

■ Plug (MIL DTL 38 999 series III Size 19)

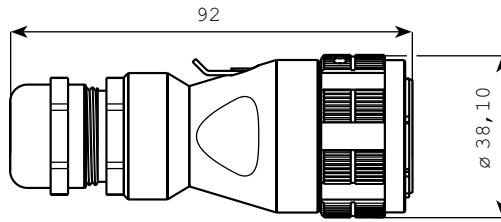
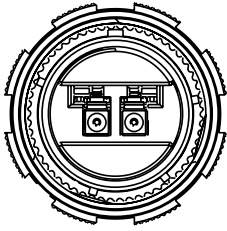

■ Square Flange Receptacle (MIL DTL 38 999 series III Size 19)

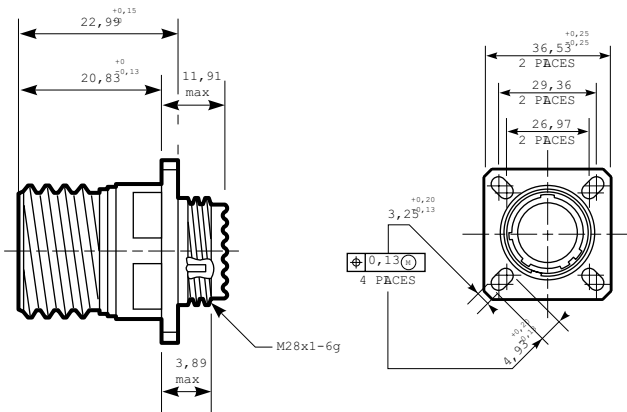

Square flange receptacle rear panel mounting

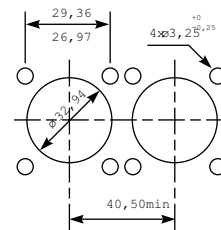

Square flange receptacle front panel mounting

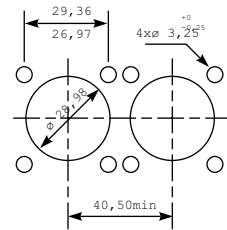

Panel Drilling

■ Jam Nut Receptacle (MIL DTL 38 999 series III Size 19)

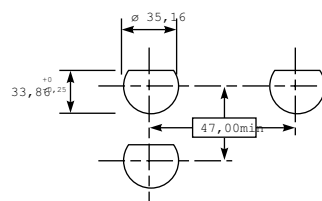
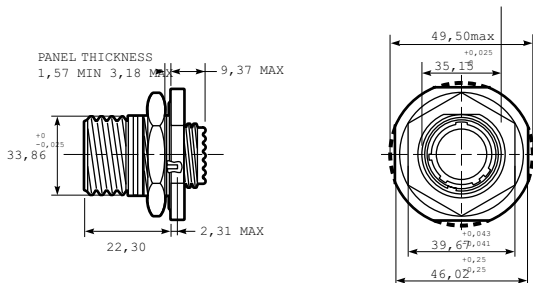

Jam nut receptacle rear panel mounting

Panel Drilling

Protective caps

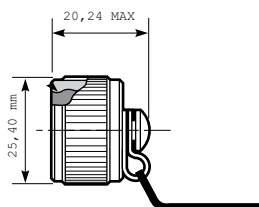

Protective cap for plug (nylon cord)

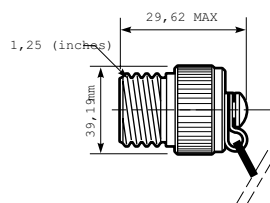

Protective cap for receptacles (nylon cord)

GLOSSARY

10BASE-T

10 Mbps Ethernet on twisted-pair (Category 3) cable.

100BASE-T

The twisted pair version of 100 Mbps Ethernet. Requires Category 5 cabling.

1000BASE-T

A recent LAN standard for implementing 1000 Mbps Ethernet on Category 5 cable. Also called Gigabit Ethernet.

Auto-MDIX

A protocol which allows two Ethernet devices to negotiate their use of the Ethernet Transmit (Tx) and Receive (Rx) cable pairs. This allows two Ethernet devices with MDI or MDI-X connectors to connect without using a cross-over cable.

Baud

A unit of measurement that denotes the number of bits that can be transmitted per second. For example, if a modem is rated at 9600 baud it is capable of transmitting data at a rate of 9600 bits per second.

Bandwidth

The maximum capacity of a network channel. Usually expressed in bits per second (bps). Ethernet channels have bandwidths of 10, 100, and 1000 Mbps (Gigabit).

bps

Bits Per Second is the unit used for measuring line speed, the number of information units transmitted per second.

Broadcast

A transmission initiated by one station and sent to all stations on the network.

Byte

The amount of memory needed to store one character such as a letter or a number. Equal to 8 bits of digital information. The standard measurement unit of a file size.

Category 5

A performance classification for twisted pair cables, connectors and systems. Specified to 100 MHz. Suitable for voice and data applications up to 155 Mbps.

Category 5 e

Also called Enhanced Category 5. A performance classification for twisted pair cables, connectors and systems. Specified to 100 MHz. Suitable for voice and data applications up to 1000 Mbps.

Category 6

A performance classification for twisted pair cables, connectors and systems. Specified up to 250 MHz.

CSMA/CD

Carrier Sense Multiple Access/Collision Detect. The Medium Access Control (MAC) protocol used in Ethernet.

Data rate

The speed of the data transmission, measured in bps (bits per second) or Mbps.

Duplex (Full, Half)

Full duplex is a communications method that allows for the simultaneous transmission and reception of data. In Half Duplex communication, transmissions and receptions can occur in either direction but not at the same time.

Ethernet

The most common network protocol in use. A protocol is a set of rules enabling data communications. Ethernet can operate over several different media including fiber optic, coaxial cable and twisted-pair cable.

IEEE 802.3

IEEE Working Group for CSMA/CD, the protocol used in Ethernet transmissions.

IGMP snooping

The ability of a switch to observe Internet Group Multicast Protocol (IGMP) traffic in order to learn IP Multicast group membership. The purpose is to restrict multicast transmissions to only those ports which have requested them.

LAN

Local Area Network. A network of directly-connected machines (located in close proximity), providing high speed communication over physical media such as fiber optics, coaxial cable, or twisted pair wiring.

MAC Address

A unique address assigned to a station interface, identifying that station on the network. With Ethernet, this is the unique 48-bit station address. Same as the physical address.

Megabit (Mb)

Megabit. One million bits of information, usually used to express a data transfer rate ; 1 Megabit/second = 1Mbps.

Megabyte (MB)

MegaByte. A unit of data storage size which represents one million characters of information.

Multicast

A transmission initiated by one station to many stations of the network.

Port Mirroring

Port mirroring allows a switch port to monitor packets from any or all of its ports so that traffic can be analysed.

Quality of Service (QoS)

Some switches support QoS (per 802.1p and 802.1Q standards) whereby messages can be assigned levels of priority. QoS is important where time-critical applications can be impaired by data delays.

RJ45

8-position modular jacks used on twisted pair links for Ethernet cabling.

RJ-Field

A wide range of connectors which allow to reinforce and seal standard RJ45 cable. See www.rjfield.com

SNMP

Simple Network Management Protocol. This is THE standard used for switch management programs.

Spanning Tree Protocol (STP)

A link management protocol providing path redundancy and preventing network loops by defining a tree to span all switches in a network. It forces redundant data paths into a standby (blocked) state. If a path malfunction occurs, the topology is reconfigured and the link reestablished by activating the standby path.

TCP/IP

Transmission Control Protocol/Internet Protocol. A set of protocols, resulting from ARPA efforts, used by the Internet to support services such as remote login (TELNET), file transfer (FTP) and mail (SMTP).

TELNET

The Internet standard protocol for remote login (terminal connection) service. TELNET allows a user at one site to interact with a remote timesharing system at another site as if the user's terminal were connected directly to the remote computer.

VLAN

Virtual Local Area Network. A LAN that maps stations on a basis other than location such as by department, user type or application. Managing traffic, workstations, and bandwidth can be easier with a VLAN and improve network efficiency.

CABLE datas

	Category 5 (Cat5)	Category 5E (Cat5E)	Category 6 (Cat6)	Category 6a (Cat6a)	Category 6A (Cat6A)	Category 7 (Cat7)
Data rate	100 MBit/s	1 GBit/s	1 GBit/s	10 GBit/s	10 GBit/s	10 GBit/s
Frequency	100 Mhz	100 Mhz	250 Mhz	500 Mhz	500 Mhz 3db	600 Mhz
Twisted pairs	2 or 4 pairs	4 pairs	4 pairs	4 pairs (each pair individually shielded)	4 pairs (each pair individually shielded)	4 pairs (each pair individually shielded)
Max lenght	100 m	100 m	55 m	100 m	100 m	100 m
Specification	ANSI/TIA-568-A 1-2001	TIA/EIA-568-5-A	ANSI/TIA-568-B. 2-1	ANSI/TIA-568-B. 2-10	ISO/IEC 11801 amendment 2	ISO/IEC 11801 2002 category7/ class F

NORTH AMERICA

Amphenol Pcd, Inc.
72 Cherry Hill Drive
Beverly, MA. 01915 - USA
Telephone:+1-978-624-3400
info@amphenolpcd.com

EUROPE

Amphenol AIR LB
10 Rue Champ Raymond,
08110 Carignan-France
Telephone:+33-3-2422-3270
Fax: +33-3-2422-387

Amphenol AIR LB GmbH
Am Kleinbahnhof 4
66740 Saarlouis-Germany
Telephone:+49-6831-981-00
Fax: +49-6831-981-030

Amphenol BENELUX
Zadelmaker 121 NL
2401 PD Alphen aan den Rijn-Netherlands
Telephone:+31-172-444-903
Fax:+31-172-240-254

Amphenol IBERICA
Edificio «Burgosol»
c/Comunidad de Madrid, 35 bis Oficina
Nº55
ES - 28230 Las Rozas - Madrid - Spain
Telephone:+34-91-640-73-02/03/04
Fax: +34-91-640-73-07

Amphenol ITALIA
Via Barbaiana n°5,
20020 Lainate-Milano-Italy
Telephone:+39-02-93254-1
Fax: +39-02-93254-444

Amphenol LIMITED
Thanet Way, Whitstable - Kent,
CT5 3JF United Kingdom
Telephone:+44-1227-773-200
Fax:+44-1227-276-571

Amphenol MIDDLE & EASTERN EUROPE
Wiener gase 68,
2380 Perchtoldsdorf - Austria
Telephone:+43-699-10396-071
Fax: +43-699-40396-071

SEFEE
ZI des Cazes - BP 243
12403 Saint Affrique - France
Telephone:+33-5-6598-1100
Fax: +33-5-6549-3712

Amphenol SCANDINAVIA
Ångsullsvägen 7 - S-187 51 Täby - Sweden
20020 Lainate-Milano-Italy
Telephone:+46-702-12-92-00
Fax: +46-702-63-46-77

Amphenol SOCAPEX
948 Promenade de l'Arve - BP29,
74311 Thyez Cedex - France
Telephone:+33-4-5089-2840
Fax:+33-4-5096-1941

Amphenol SOUTH EASTERN EUROPE
948 Promenade de l'Arve - BP29
74311 Thyez Cedex - France
Telephone:+33-4-5089-2840
Fax: +33-4-5096-1941

ASIA

Amphenol DAESHIN
558 Sosa, SongNea
Bucheon-city, Kyunggi-Do
Korea 420-130
Telephone:+82-32-610-3800
Fax:+82-32-673-2507/665-6219

Amphenol INTERCONNECT INDIA
PRIVATE LIMITED
105 Bhosari industrial Area
Pune 411 026 - India
Telephone:+91-20-712-
0363/0463/0155
Fax:+91-20-712-0581

Amphenol JAPAN
689-1, Iseochi
Ritto-shi Shiga 520-3044-Japan
Korea 420-130
Telephone:+81-77-553-8501
Fax:+81-77-551-2200

Amphenol PCD CO.LTD
2/F Building A5,
Huafeng Technology Park
Guan Tian, Bei Huan Road,
Shi Yan Street
BaoAn District, Shenzhen,
China 518132
Telephone:+86-755-8173-8281
Fax:+86-755-8173-8180
www.amphenolpcd.com.cn

OTHER AREAS

Amphenol ARGENTINA
Av. Callao 930 2do piso Oficina B «Plaza»
C1023 - AAP Buenos Aires - Argentina
Telephone:+54-11-4815-6886
Fax: +54-11-4814-5779

Amphenol AUSTRALIA PTY LIMITED
2 Fiveways Blvd, Keysborough
Melbourne, Victoria 3173 - Australia
Telephone:+61-3-8796-8888
Fax: +61-3-8796-8801

BAR TEC LTD
4 Hagavish St, PO Box 279
Kfar Saba 44102 - Israël
Telephone:+972-9-767-4097
Fax:+972-9-767-4324

Amphenol DO BRAZIL
Rua Diogo Moreira, 132, 20 andar, rooms 2001-2-3
CEP: 05423-010 Sao Paulo SP - Brazil
Telephone:+55-11-3815-1003
Fax: +55-11-3815-1629

Amphenol MEXICO
Prolongacion Reforma 61 - 6 B2
Col.Paseo de las Lomas - C.P.013130 - Mexico
Telephone:+52-55-5258-9984
Fax: +52-55-5081-6890

Amphenol RUSSIA
8 bldg., 2 Yaroslavskaja Street,
129164 Moscow - Russia
Telephone:+7-495-937-6341
Fax:+7-495-937-6319

Amphenol SOUTH AFRICA
30 Impala Road
2196 Chislehurst - Sandton - South Africa
Telephone:+27-11-783-9517
Fax: +27-11-783-9519

Amphenol TÜRKIYE & MIDDLE EAST
Maslak Mah. Bilim sok. No:5
Sun Plaza Kat:15
34398 Sisli Istanbul Turkiye
Telephone:+90-212-367-92-20
Fax:+90-212-367-92-21

Amphenol

The information given in this document are **as a guideline only**.

We reserve the right to **modify our products** in any way we deem necessary.

Any duplication is **prohibited**, unless approved in writing.

Design by **Amphenol** - September 2012

Generation & Edition by **Amphenol**

Your local Contact:

DOC-000075-ANG

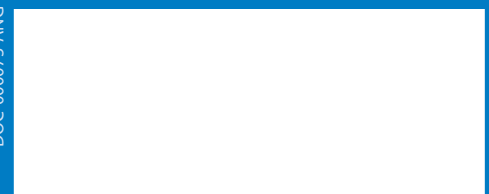

For more information, please visit our websites:

www.rjfield.com - www.usbfield.com - www.fwfield.com - www.rjswitch.com

Компания «Океан Электроники» предлагает заключение долгосрочных отношений при поставках импортных электронных компонентов на взаимовыгодных условиях!

Наши преимущества:

- Поставка оригинальных импортных электронных компонентов напрямую с производств Америки, Европы и Азии, а так же с крупнейших складов мира;
- Широкая линейка поставок активных и пассивных импортных электронных компонентов (более 30 млн. наименований);
- Поставка сложных, дефицитных, либо снятых с производства позиций;
- Оперативные сроки поставки под заказ (от 5 рабочих дней);
- Экспресс доставка в любую точку России;
- Помощь Конструкторского Отдела и консультации квалифицированных инженеров;
- Техническая поддержка проекта, помощь в подборе аналогов, поставка прототипов;
- Поставка электронных компонентов под контролем ВП;
- Система менеджмента качества сертифицирована по Международному стандарту ISO 9001;
- При необходимости вся продукция военного и аэрокосмического назначения проходит испытания и сертификацию в лаборатории (по согласованию с заказчиком);
- Поставка специализированных компонентов военного и аэрокосмического уровня качества (Xilinx, Altera, Analog Devices, Intersil, Interpoint, Microsemi, Actel, Aeroflex, Peregrine, VPT, Syfer, Eurofarad, Texas Instruments, MS Kennedy, Miteq, Cobham, E2V, MA-COM, Hittite, Mini-Circuits, General Dynamics и др.);

Компания «Океан Электроники» является официальным дистрибьютором и эксклюзивным представителем в России одного из крупнейших производителей разъемов военного и аэрокосмического назначения «JONHON», а так же официальным дистрибьютором и эксклюзивным представителем в России производителя высокотехнологичных и надежных решений для передачи СВЧ сигналов «FORSTAR».



JONHON

«JONHON» (основан в 1970 г.)

Разъемы специального, военного и аэрокосмического назначения:

(Применяются в военной, авиационной, аэрокосмической, морской, железнодорожной, горно- и нефтедобывающей отраслях промышленности)

«FORSTAR» (основан в 1998 г.)

ВЧ соединители, коаксиальные кабели, кабельные сборки и микроволновые компоненты:

(Применяются в телекоммуникациях гражданского и специального назначения, в средствах связи, РЛС, а так же военной, авиационной и аэрокосмической отраслях промышленности).



Телефон: 8 (812) 309-75-97 (многоканальный)

Факс: 8 (812) 320-03-32

Электронная почта: ocean@oceanchips.ru

Web: <http://oceanchips.ru/>

Адрес: 198099, г. Санкт-Петербург, ул. Калинина, д. 2, корп. 4, лит. А