

ISL85014EVAL1Z

Evaluation Board User Guide

UG113
Rev.0.00
Feb 15, 2017

Description

The [ISL85014](#) is a 3.8V to 18V input, 14A synchronous buck regulator for applications with input voltage from multi-cell batteries or regulated 5V and 12V power rails. The device also provides an integrated bootstrap diode for the high-side gate driver to reduce the external parts count. The ISL85014EVAL1Z platform allows quick evaluation of the high-performance features of the ISL85014 buck regulator.

Specifications

This board has been configured and optimized for the following operating conditions:

- Input voltage ranges from 4.5V to 18V
- 1.8V nominal output voltage
- Up to 14A output current capability
- Default internally set to 600kHz switching frequency
- Default internally set to 3ms soft-start
- Operating temperature range: -40°C to +85°C

Key Features

- Switch selectable EN (enabled/disabled)
- Frequency synchronization option
- Jumper selectable mode (DEM/Forced CCM)
- Jumper selectable OCP mode (Hiccup/Latch-off)
- Jumper selectable frequency (600kHz/300kHz)
- Connectors and test points for easy probing
- Compact design

Related Literature

- For a full list of related documents, visit our website - [ISL85014](#) product pages

Ordering Information

PART NUMBER	DESCRIPTION
ISL85014EVAL1Z	Evaluation board for ISL85014FRZ

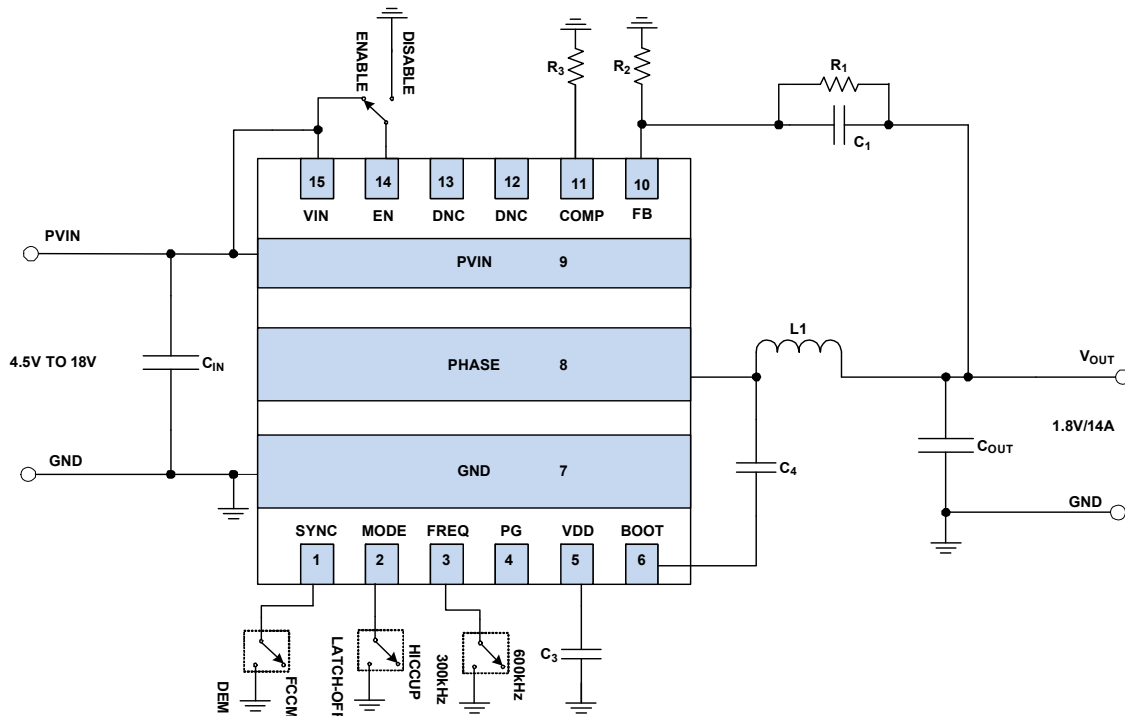

FIGURE 1. BLOCK DIAGRAM

Connector and Test Point Descriptions

The ISL85014EVAL1Z evaluation board includes I/O connectors and test points as shown in [Table 1](#).

TABLE 1. CONNECTORS AND TEST POINTS

REFERENCE DESIGNATOR	DESCRIPTION
J1	Input voltage positive connection
J2	Output voltage positive connection
J3	Input voltage return connection
J4	Output voltage return connection
J6	Two-position socket connector for PHASE to GND test
J7	Two-position socket connector for VOUT to GND test
PVIN	PVIN positive test point
GND	GND test point
VIN	VIN positive test point
VOUT	Output voltage positive test point
SYNC	External synchronization clock connection
EN	Enable test point
VDD	Internal LDO output test point
PG	Power-good output

Selection Switch and Jumper Descriptions

- Switch SW5 (Enable)
The switch enables and disables the ISL85014:
 - When the switch is in the ON position, the ISL85014 is enabled.
 - When the switch is in the OFF position, the ISL85014 is disabled.
- Jumper J9
The jumper provides the selection of different operating modes, detailed as follows:
 - When the jumper is in the FCCM position, the ISL85014 operates in Forced CCM.
 - When the jumper is in the DEM position, the ISL85014 operates in Diode Emulation mode and enables automatic transition from CCM to DCM at light-load conditions.
- Jumper J10 sets the switching frequency at either 600kHz or 300kHz.
- Jumper J11 sets the OCP scheme in either Hiccup mode or Latch-Off mode.

Quick Setup Guide

Refer to the following instructions to configure and power-up the board for proper operation.

1. Set the power supply voltage to 12V and turn off the power supply. Connect the positive output of the power supply to J1 (PVIN) and the negative output to J3 (GND).
2. Connect an electronic load to J2 (VOUT) for the positive connection and J4 (GND) for the negative connection.
3. Measure the output voltage (test points VOUT and GND) with the voltmeter.
4. Place scope probes on VOUT test point (J7) and other test points of interest.
5. Toggle selection switch SW5 to ON position.
6. Set the load current to 0.1A and turn on the power supply. The output voltage should be in regulation with a nominal 1.8V output.
7. Slowly increase the load up to 14A while monitoring the output voltage, which should remain in regulation with a nominal 1.8V output.
8. Slowly sweep VIN from 4.5V to 18V. The output voltage should remain in regulation with a nominal 1.8V output.
9. Decrease the input voltage to 0V to shut down the regulator.

Frequency Synchronization

The ISL85014 can be synchronized to an external clock with frequency ranges from 100kHz to 1MHz by applying the external clock to test point SYNC on the ISL85014EVAL1Z evaluation board. The external clock should meet the specifications of pulse width and voltage level described in the [ISL85014](#) datasheet.

Evaluating Other Output Voltages

The ISL85014EVAL1Z has a nominal 1.8V output voltage. The output voltage is programmable by an external resistor divider formed by R_1 and R_2 as shown in [Figure 1](#) on [page 1](#). R_1 is usually chosen first, then the value for R_2 can be calculated based on R_1 and the desired output voltage using [Equation 1](#):

$$R_2 = \frac{R_1 \cdot 0.6V}{V_{OUT} - 0.6V} \quad (\text{EQ. 1})$$

PCB Layout Considerations

The PCB layout is critical for proper operation of the ISL85014. The following guidelines should be followed to achieve good performance.

1. Use a multilayer PCB structure to achieve optimized performance. A four-layer PCB is recommended for this design.
2. Use a combination of bulk capacitors and smaller ceramic capacitors with lower ESL for the input capacitors, and place them as close to the IC as possible.
3. Place the VDD decoupling capacitor close to the IC between VDD and GND. A 1 μ F ceramic capacitor is typically used.
4. Place a bootstrap capacitor close to the IC between the BOOT and PHASE pins. A 0.1 μ F ceramic capacitor is typically used.
5. Connect the feedback resistor divider between the output capacitor positive terminal and AGND pin of the IC, and place the resistors close to the FB pin of the IC.
6. Connect the GND of the IC to the ground planes underneath using multiple thermal vias to improve thermal performance.

ISL85014EVAL1Z Evaluation Board

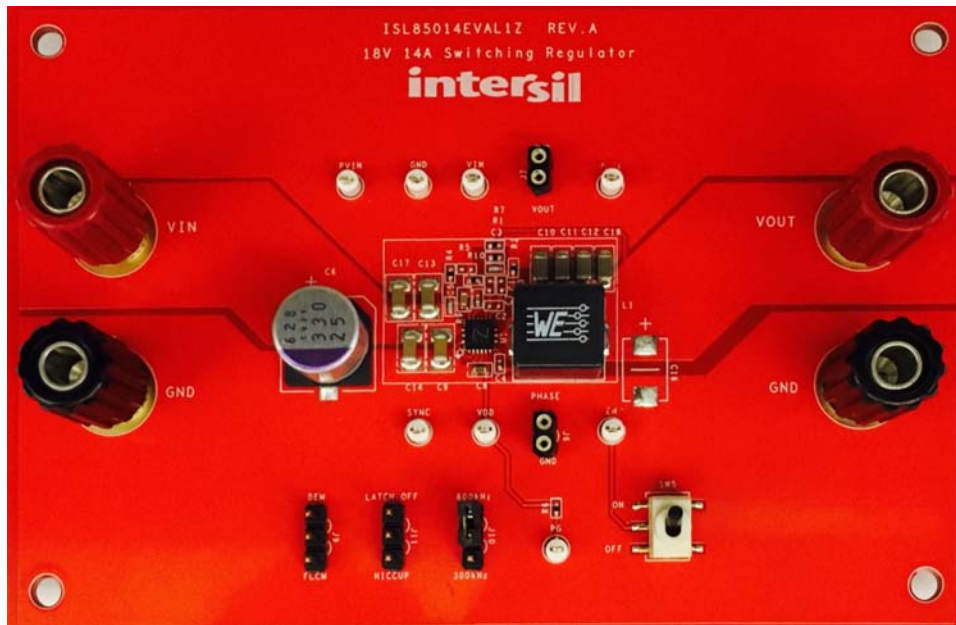

FIGURE 2. TOP VIEW

ISL85014EVAL1Z Schematic

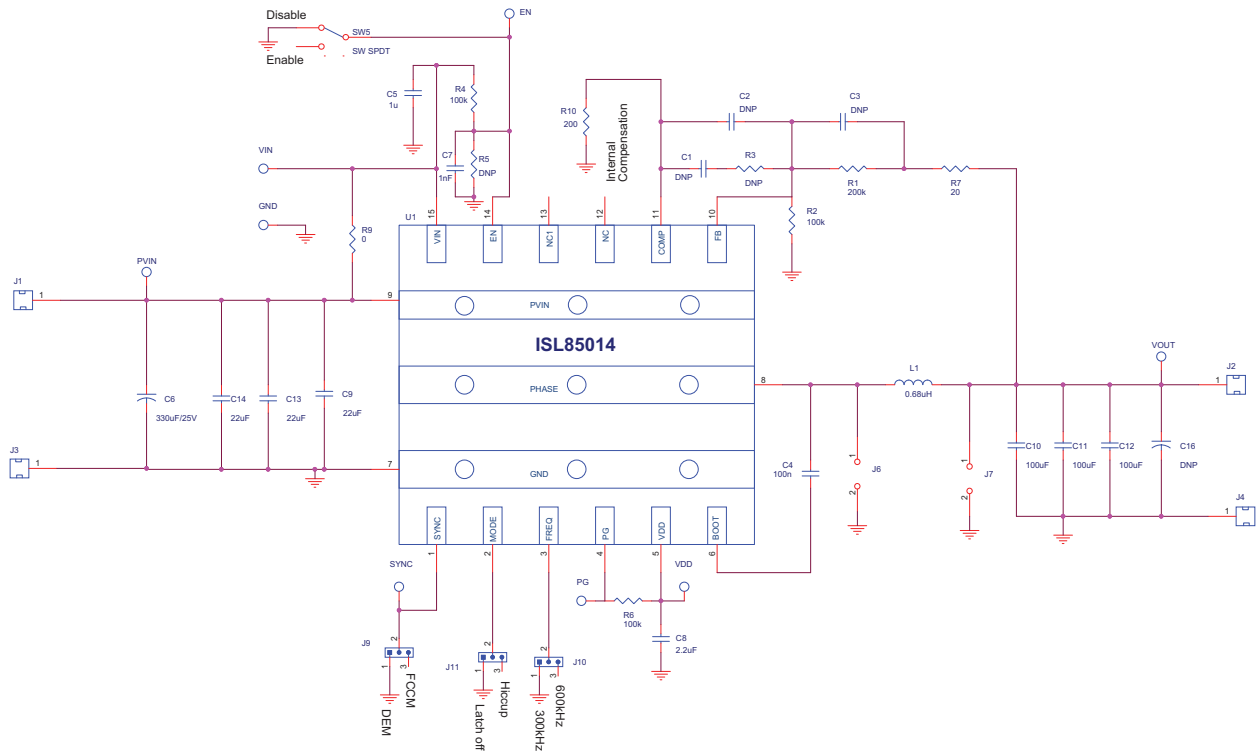

FIGURE 3. ISL85014EVAL1Z SCHEMATIC

Bill of Materials

REFERENCE DESIGNATOR	QTY	DESCRIPTION	PART NUMBER	MANUFACTURER
U1	1	IC-14A BUCK REGULATOR, 15P, TDFN, 3.5x3.5, ROHS	ISL85014FRZ	INTERSIL
C6	1	CAP-OSCON, SMD, 10.3x10.3mm, 330µF, 25V, 20%, 14mΩ, ROHS	25SVPF330M	SANYO
C4	1	CAP, SMD, 0402, 0.1µF, 50V, 10%, X7R, ROHS	C1005X7R1H104K	TDK
C5	1	CAP, SMD, 0603, 1.0µF, 25V, 10%, X5R, ROHS	GRM188R61E105KA12D	MURATA
C8	1	CAP, SMD, 0603, 2.2µF, 10V, 10%, X7R, ROHS	GRM188R71A225KE15D	MURATA
C10, C11, C12, C18	4	CAP, SMD, 1206, 100µF, 6.3V, 20%, X5R, ROHS	GRM31CR60J107ME39L	MURATA
C9, C13, C14, C17	4	CAP, SMD, 1210, 22µF, 25V, 10%, X7R, ROHS	GRM32ER71E226KE15L	MURATA
J6, J7	2	CONN-SOCKET STRIP, TH, 2P, 2.54mmPITCH, ROHS	310-87-102-41-001101	PRECI-DIP
VDD, SYNC, PG, EN, GND, VIN, PVIN, VOUT	8	CONN-MINI TEST POINT, VERTICAL, WHITE, ROHS	5002	KEYSTONE
J9, J10, J11	3	CONN-HEADER, 1x3, BREAKAWY 1x36, 2.54mm, ROHS	68001-203HLF	BERG/FCI
L1	1	COIL-PWR CHOKE, SMD, 10x10x9.0mm, 0.68µH, 20%, ROHS	7443330068	WURTH ELEKTRONIK
R7	1	RES, SMD, 0402, 20Ω, 1/16W, 1%, TF, ROHS	ERJ2RKF20R0	PANASONIC
R9	1	RES, SMD, 0402, 0Ω, 1/16W, 5%, TF, ROHS	CR0402-16W-00T	VENKEL
R2, R4, R6	3	RES, SMD, 0402, 100k, 1/16W, 1%, TF, ROHS	ERJ2RKF1003	PANASONIC
R10	1	RES, SMD, 0402, 200Ω, 1/16W, 1%, TF, ROHS	ERJ-2RKF2000X	PANASONIC
R1	1	RES, SMD, 0402, 200k, 1/16W, 1%, TF, ROHS	MCR01MZPF2003	ROHM
C7	1	CAP, SMD, 0402, 1nF, 50V, 10%, X7R, ROHS		MURATA
SW5	1	SWITCH-TOGGLE, SMD, 6PIN, SPDT, 2POS, ON-NONE-ON, ROHS	GT11MSCBE-T	ITT INDUSTRIES/C&K DIVISION
J1, J2	2	CONN-GEN, BIND. POST, INSUL-RED, THMBNUT-GND	111-0702-001	JOHNSONS
J3, J4	2	CONN-GEN, BIND. POST, INSUL-BLK, THMBNUT-GND	111-0703-001	JOHNSONS
Jumper	1	CONN-JUMPER, SHORTING, 2PIN, BLK, OPEN TOP, 2.54mmPITCH, ROHS	929950-00	3M
R3, R5	0	RES, SMD, 0402, DNP, TF, ROHS		
C1, C2, C3, C16	0	CAP, SMD DNP-PLACE HOLDER, ROHS		
PCB	1	PWB-PCB, ISL85014EVAL1Z, REVA, ROHS	ISL85014EVAL1Z	Any

Typical Performance Curves

$V_{IN} = 12V$, $V_{OUT} = 1.8V$, $L = 0.68\mu H$, $f_{SW} = 600kHz$, $T_A = +25^\circ C$, unless otherwise noted.

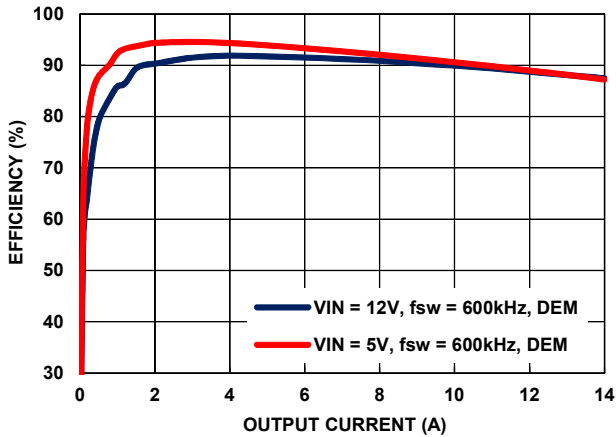

FIGURE 8. EFFICIENCY vs LOAD

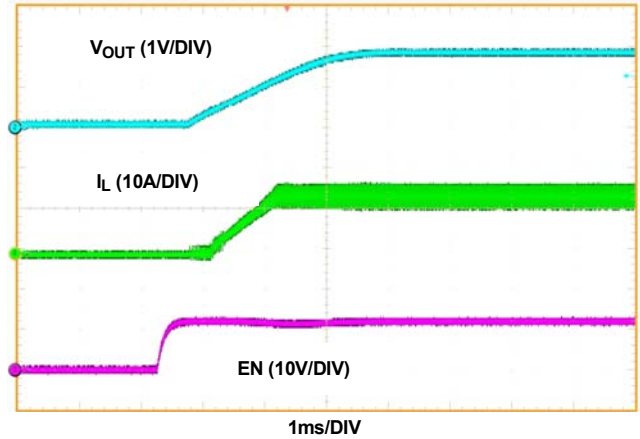

FIGURE 9. START-UP WITH EN, $I_{OUT} = 14A$

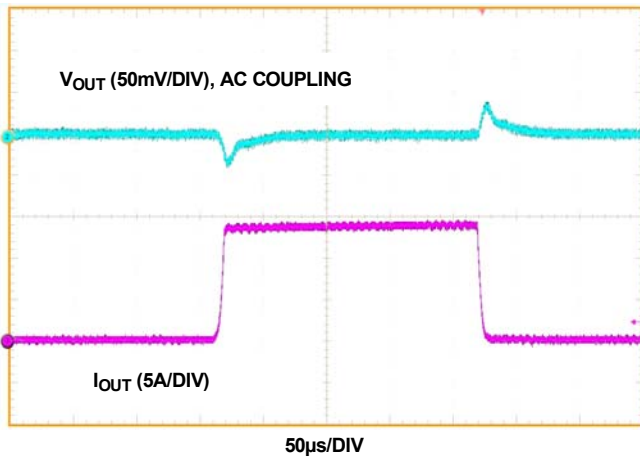

FIGURE 10. LOAD TRANSIENT, $0A \rightarrow 14A \rightarrow 0A$, $2.5A/\mu s$

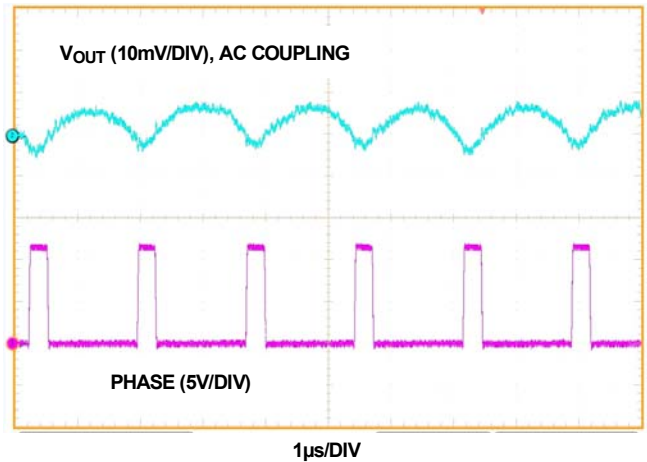

FIGURE 11. OUTPUT VOLTAGE RIPPLE, $I_{OUT} = 14A$

Notice

1. Descriptions of circuits, software and other related information in this document are provided only to illustrate the operation of semiconductor products and application examples. You are fully responsible for the incorporation or any other use of the circuits, software, and information in the design of your product or system. Renesas Electronics disclaims any and all liability for any losses and damages incurred by you or third parties arising from the use of these circuits, software, or information.
2. Renesas Electronics hereby expressly disclaims any warranties against and liability for infringement or any other claims involving patents, copyrights, or other intellectual property rights of third parties, by or arising from the use of Renesas Electronics products or technical information described in this document, including but not limited to, the product data, drawings, charts, programs, algorithms, and application examples.
3. No license, express, implied or otherwise, is granted hereby under any patents, copyrights or other intellectual property rights of Renesas Electronics or others.
4. You shall not alter, modify, copy, or reverse engineer any Renesas Electronics product, whether in whole or in part. Renesas Electronics disclaims any and all liability for any losses or damages incurred by you or third parties arising from such alteration, modification, copying or reverse engineering.
5. Renesas Electronics products are classified according to the following two quality grades: "Standard" and "High Quality". The intended applications for each Renesas Electronics product depends on the product's quality grade, as indicated below.
"Standard": Computers; office equipment; communications equipment; test and measurement equipment; audio and visual equipment; home electronic appliances; machine tools; personal electronic equipment; industrial robots; etc.
"High Quality": Transportation equipment (automobiles, trains, ships, etc.); traffic control (traffic lights); large-scale communication equipment; key financial terminal systems; safety control equipment; etc.
Unless expressly designated as a high reliability product or a product for harsh environments in a Renesas Electronics data sheet or other Renesas Electronics document, Renesas Electronics products are not intended or authorized for use in products or systems that may pose a direct threat to human life or bodily injury (artificial life support devices or systems; surgical implantations; etc.), or may cause serious property damage (space system; undersea repeaters; nuclear power control systems; aircraft control systems; key plant systems; military equipment; etc.). Renesas Electronics disclaims any and all liability for any damages or losses incurred by you or any third parties arising from the use of any Renesas Electronics product that is inconsistent with any Renesas Electronics data sheet, user's manual or other Renesas Electronics document.
6. When using Renesas Electronics products, refer to the latest product information (data sheets, user's manuals, application notes, "General Notes for Handling and Using Semiconductor Devices" in the reliability handbook, etc.), and ensure that usage conditions are within the ranges specified by Renesas Electronics with respect to maximum ratings, operating power supply voltage range, heat dissipation characteristics, installation, etc. Renesas Electronics disclaims any and all liability for any malfunctions, failure or accident arising out of the use of Renesas Electronics products outside of such specified ranges.
7. Although Renesas Electronics endeavors to improve the quality and reliability of Renesas Electronics products, semiconductor products have specific characteristics, such as the occurrence of failure at a certain rate and malfunctions under certain use conditions. Unless designated as a high reliability product or a product for harsh environments in a Renesas Electronics data sheet or other Renesas Electronics document, Renesas Electronics products are not subject to radiation resistance design. You are responsible for implementing safety measures to guard against the possibility of bodily injury, injury or damage caused by fire, and/or danger to the public in the event of a failure or malfunction of Renesas Electronics products, such as safety design for hardware and software, including but not limited to redundancy, fire control and malfunction prevention, appropriate treatment for aging degradation or any other appropriate measures. Because the evaluation of microcomputer software alone is very difficult and impractical, you are responsible for evaluating the safety of the final products or systems manufactured by you.
8. Please contact a Renesas Electronics sales office for details as to environmental matters such as the environmental compatibility of each Renesas Electronics product. You are responsible for carefully and sufficiently investigating applicable laws and regulations that regulate the inclusion or use of controlled substances, including without limitation, the EU RoHS Directive, and using Renesas Electronics products in compliance with all these applicable laws and regulations. Renesas Electronics disclaims any and all liability for damages or losses occurring as a result of your noncompliance with applicable laws and regulations.
9. Renesas Electronics products and technologies shall not be used for or incorporated into any products or systems whose manufacture, use, or sale is prohibited under any applicable domestic or foreign laws or regulations. You shall comply with any applicable export control laws and regulations promulgated and administered by the governments of any countries asserting jurisdiction over the parties or transactions.
10. It is the responsibility of the buyer or distributor of Renesas Electronics products, or any other party who distributes, disposes of, or otherwise sells or transfers the product to a third party, to notify such third party in advance of the contents and conditions set forth in this document.
11. This document shall not be reprinted, reproduced or duplicated in any form, in whole or in part, without prior written consent of Renesas Electronics.
12. Please contact a Renesas Electronics sales office if you have any questions regarding the information contained in this document or Renesas Electronics products.
(Note 1) "Renesas Electronics" as used in this document means Renesas Electronics Corporation and also includes its directly or indirectly controlled subsidiaries.
(Note 2) "Renesas Electronics product(s)" means any product developed or manufactured by or for Renesas Electronics.

(Rev.4.0-1 November 2017)



SALES OFFICES

Renesas Electronics Corporation

<http://www.renesas.com>

Refer to "<http://www.renesas.com/>" for the latest and detailed information.

Renesas Electronics America Inc.
1001 Murphy Ranch Road, Milpitas, CA 95035, U.S.A.
Tel: +1-408-432-8888, Fax: +1-408-434-5351

Renesas Electronics Canada Limited
9251 Yonge Street, Suite 8309 Richmond Hill, Ontario Canada L4C 9T3
Tel: +1-905-237-2004

Renesas Electronics Europe Limited
Dukes Meadow, Millboard Road, Bourne End, Buckinghamshire, SL8 5FH, U.K
Tel: +44-1628-651-700, Fax: +44-1628-651-804

Renesas Electronics Europe GmbH
Arcadiastrasse 10, 40472 Düsseldorf, Germany
Tel: +49-211-6503-0, Fax: +49-211-6503-1327

Renesas Electronics (China) Co., Ltd.
Room 1709 Quantum Plaza, No.27 ZhichunLu, Haidian District, Beijing, 100191 P. R. China
Tel: +86-10-8235-1155, Fax: +86-10-8235-7679

Renesas Electronics (Shanghai) Co., Ltd.
Unit 301, Tower A, Central Towers, 555 Langao Road, Putuo District, Shanghai, 200333 P. R. China
Tel: +86-21-2226-0888, Fax: +86-21-2226-0999

Renesas Electronics Hong Kong Limited
Unit 1601-1611, 16/F., Tower 2, Grand Century Place, 193 Prince Edward Road West, Mongkok, Kowloon, Hong Kong
Tel: +852-2265-6688, Fax: +852-2886-9022

Renesas Electronics Taiwan Co., Ltd.
13F, No. 363, Fu Shing North Road, Taipei 10543, Taiwan
Tel: +886-2-8175-9600, Fax: +886-2-8175-9670

Renesas Electronics Singapore Pte. Ltd.
80 Bendemeer Road, Unit #06-02 Hyflux Innovation Centre, Singapore 339949
Tel: +65-6213-0200, Fax: +65-6213-0300

Renesas Electronics Malaysia Sdn.Bhd.
Unit 1207, Block B, Menara Amcorp, Amcorp Trade Centre, No. 18, Jln Persiaran Barat, 46050 Petaling Jaya, Selangor Darul Ehsan, Malaysia
Tel: +60-3-7955-9390, Fax: +60-3-7955-9510

Renesas Electronics India Pvt. Ltd.
No.777C, 100 Feet Road, HAL 2nd Stage, Indiranagar, Bangalore 560 038, India
Tel: +91-80-67208700, Fax: +91-80-67208777

Renesas Electronics Korea Co., Ltd.
17F, KAMCO Yangjae Tower, 262, Gangnam-daero, Gangnam-gu, Seoul, 06265 Korea
Tel: +82-2-558-3737, Fax: +82-2-558-5338

Компания «Океан Электроники» предлагает заключение долгосрочных отношений при поставках импортных электронных компонентов на взаимовыгодных условиях!

Наши преимущества:

- Поставка оригинальных импортных электронных компонентов напрямую с производств Америки, Европы и Азии, а так же с крупнейших складов мира;
- Широкая линейка поставок активных и пассивных импортных электронных компонентов (более 30 млн. наименований);
- Поставка сложных, дефицитных, либо снятых с производства позиций;
- Оперативные сроки поставки под заказ (от 5 рабочих дней);
- Экспресс доставка в любую точку России;
- Помощь Конструкторского Отдела и консультации квалифицированных инженеров;
- Техническая поддержка проекта, помощь в подборе аналогов, поставка прототипов;
- Поставка электронных компонентов под контролем ВП;
- Система менеджмента качества сертифицирована по Международному стандарту ISO 9001;
- При необходимости вся продукция военного и аэрокосмического назначения проходит испытания и сертификацию в лаборатории (по согласованию с заказчиком);
- Поставка специализированных компонентов военного и аэрокосмического уровня качества (Xilinx, Altera, Analog Devices, Intersil, Interpoint, Microsemi, Actel, Aeroflex, Peregrine, VPT, Syfer, Eurofarad, Texas Instruments, MS Kennedy, Miteq, Cobham, E2V, MA-COM, Hittite, Mini-Circuits, General Dynamics и др.);

Компания «Океан Электроники» является официальным дистрибьютором и эксклюзивным представителем в России одного из крупнейших производителей разъемов военного и аэрокосмического назначения «JONHON», а так же официальным дистрибьютором и эксклюзивным представителем в России производителя высокотехнологичных и надежных решений для передачи СВЧ сигналов «FORSTAR».



JONHON

«JONHON» (основан в 1970 г.)

Разъемы специального, военного и аэрокосмического назначения:

(Применяются в военной, авиационной, аэрокосмической, морской, железнодорожной, горно- и нефтедобывающей отраслях промышленности)

«FORSTAR» (основан в 1998 г.)

ВЧ соединители, коаксиальные кабели, кабельные сборки и микроволновые компоненты:

(Применяются в телекоммуникациях гражданского и специального назначения, в средствах связи, РЛС, а так же военной, авиационной и аэрокосмической отраслях промышленности).



Телефон: 8 (812) 309-75-97 (многоканальный)

Факс: 8 (812) 320-03-32

Электронная почта: ocean@oceanchips.ru

Web: <http://oceanchips.ru/>

Адрес: 198099, г. Санкт-Петербург, ул. Калинина, д. 2, корп. 4, лит. А