

## PLL Clock Generator ICs with Built-In Divider/Multiplier Circuits

### GENERAL DESCRIPTION

The XC25BS7 series are high frequency, low power consumption PLL clock generator ICs with divider circuit & multiplier PLL circuit. Laser trimming gives the option of being able to select from input divider ratios (M) of 1 to 256 and output divider ratios (N) of 1 to 256. Output frequency (fQ0) is equal to reference clock oscillation (fCLKin) multiplied by N/M, within a range of 1MHz to 100MHz. Further, frequency within a range of 32kHz to 36MHz can be inputted as a reference clock. The IC stops operation when low level signal is inputted to the CE pin. For this, consumption current can be reduced and output will be one of high-impedance. Because the series is semi-custom, please ask Torex sales contacts for your requested specifications such as input/output frequency, supply voltage. However, the series has the limit of specifications; therefore, your request may not be fully satisfied with your requested frequency range.

### APPLICATIONS

- Clock for controlling a Imaging dot Microcomputer and HDD drives
- Cordless phones
- Wireless communication equipment
- PDA's
- Cameras, VCRs
- Various system clocks

### FEATURES

- Input Frequency : 32kHz ~ 36MHz <sup>(\*)1</sup>
- Output Frequency : 1MHz ~ 100MHz  
(fQ0=fCLKin × N/M) <sup>(\*)1</sup>
- Output Divider (N) : Selectable from divisions from 1 to 256 <sup>(\*)1</sup>
- Input Divider (M) : Selectable from divisions from 1 to 256 <sup>(\*)1</sup>
- Operating Voltage Range : 2.50V ~ 5.50V <sup>(\*)1</sup>
- Low Power Consumption : CMOS with stand-by function <sup>(\*)2</sup>  
(10μA, MAX. when stand-by)
- Ultra Small Packages : SOT-25, USP-6C

\*1: The series are semi-custom products. Specifications for each product are limited within the above range. The input frequency range is set within ±5% of customer's designated typical frequency.

\*2: When the IC is in stand-by mode, the output becomes high impedance and the IC stops operation.

### TYPICAL APPLICATION CIRCUIT

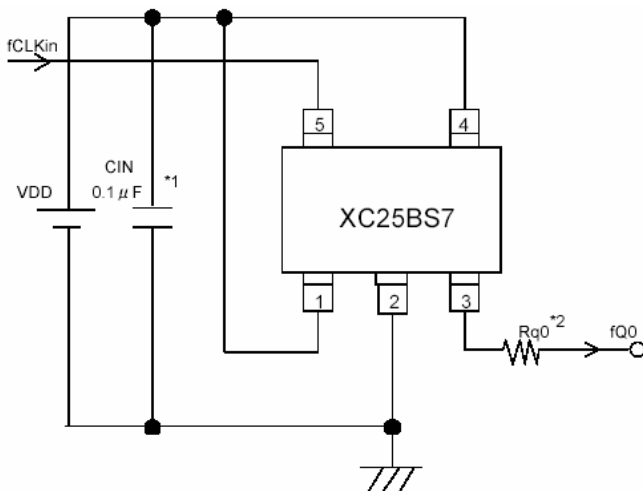

\*1: C<sub>IN</sub> (by-pass capacitor, 0.1 μF) should be connected to the IC as close as possible.

\*2: R<sub>q0</sub> is a resistor for unwanted radiation only to use when needed.

### TYPICAL PERFORMANCE CHARACTERISTICS

PLL output signal jitter 2 (equivalent to an input signal)  
XC25BS7001xx (256 multiplier, Input 48kHz, TYP.)

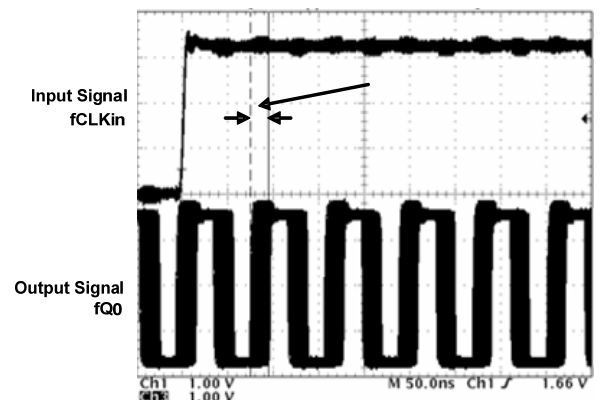

## PIN CONFIGURATION

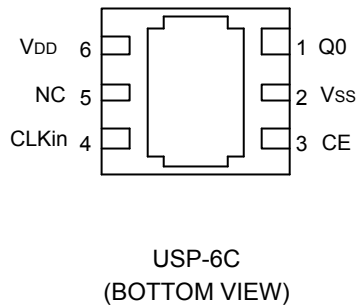
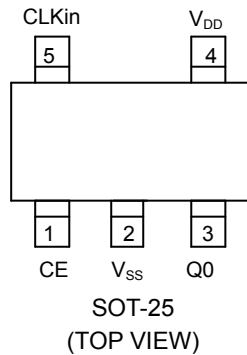

\* The dissipation pad (TAB) of the bottom view of the USP-6C package should be connected to the  $V_{SS}$  (No. 2) pin.

## PIN ASSIGNMENT

PIN NUMBER		PIN NAME	FUNCTION
SOT-25	USP-6C		
3	1	Q0	Clock Output
2	2	$V_{SS}$	Ground
1	3	CE	Stand-by Control
5	4	CLKin	Reference Clock Signal Input
-	5	NC	No Connection
4	6	$V_{DD}$	Power Input

## FUNCTION LIST

CE	'H'	'L' or OPEN
Q0	Signal Output	High Impedance

H: High level input

L: Low level input (stand-by mode)

## PRODUCT CLASSIFICATION

Ordering Information

XC25BS7 \_\_\_\_\_

DESIGNATOR	DESCRIPTION	SYMBOL	DESCRIPTION
	Product Number	Integer	: Based on internal standards e.g. product number 001 =001
	Packages	M	: SOT-25
		E	: USP-6C
	Device Orientation	R	: Embossed tape, standard feed
		L	: Embossed tape, reverse feed

## BLOCK DIAGRAM

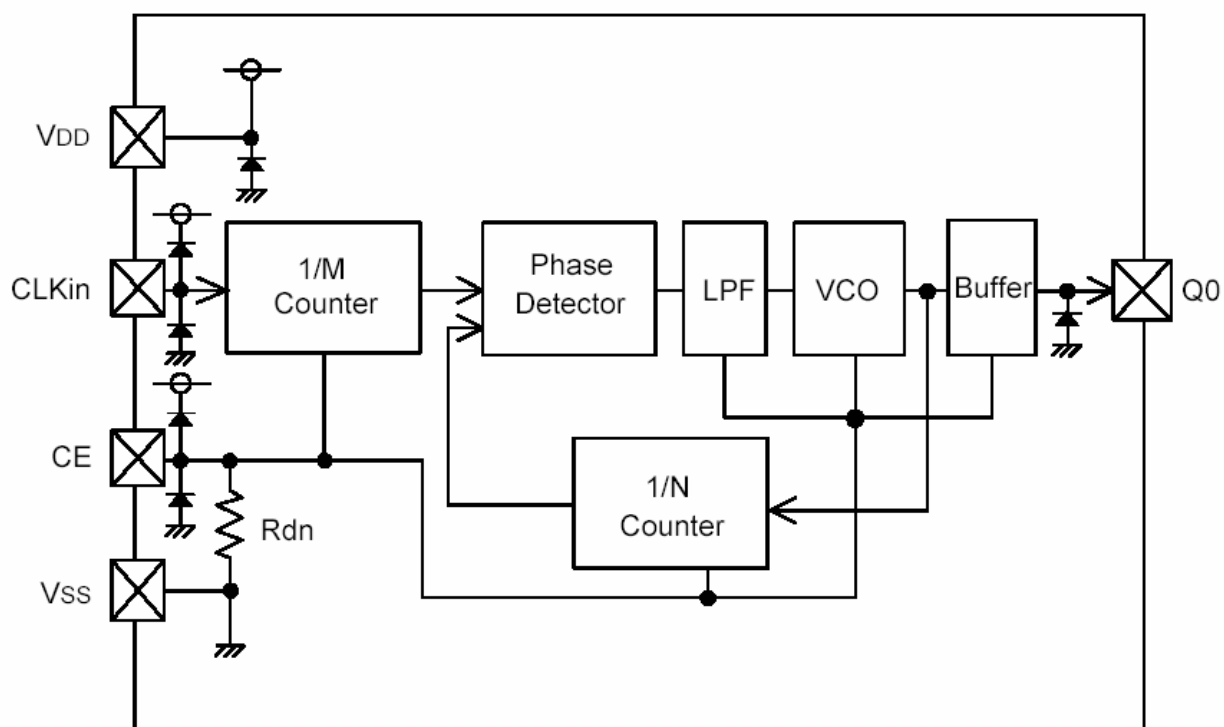

## ABSOLUTE MAXIMUM RATINGS

Ta=25

PARAMETER	SYMBOL	RATINGS	UNIT
Supply Voltage	V <sub>DD</sub>	V <sub>SS</sub> - 0.3 ~ V <sub>SS</sub> + 7.0	V
CLKIn Pin Input Voltage	V <sub>CK</sub>	V <sub>SS</sub> - 0.3 ~ V <sub>DD</sub> + 0.3	V
CE Pin Input Voltage	V <sub>CE</sub>	V <sub>SS</sub> - 0.3 ~ V <sub>DD</sub> + 0.3	V
Q0 Pin Output Voltage	V <sub>Q0</sub>	V <sub>SS</sub> - 0.3 ~ V <sub>DD</sub> + 0.3	V
Q0 Pin Output Current	I <sub>Q0</sub>	± 50	mA
Power Dissipation	SOT-25	150	mW
	USP-6C	100	mW
Operating Temperature Range	T <sub>opr</sub>	-40 ~ +85	°C
Storage Temperature Range	T <sub>stg</sub>	-55 ~ +125	°C

## ELECTRICAL CHARACTERISTICS

Characteristics example by product series

- \*1: The chart below introduces the products with typical specification characteristics which is under production or production in the past.
- \*2: The series are semi-custom products. Specifications for each product are limited within the range below. The input frequency is set within  $\pm 5\%$  of customer's designated typical frequency.
- \*3: For other part number with other input-output frequency or multiplication, please ask Torex sales contacts.

XC25BS7001xx (256 multiplication)

PARAMETER	SYMBOL	MIN.	TYP.	MAX.	UNIT
Input Frequency	fCLKin	-	48.000	-	kHz
Multiplier/Divider Ratio	N/M	-	256	-	Multiplier
PLL Output Frequency	fQ0	-	12.288	-	MHz

XC25BS7007xx (0.333 multiplication)

PARAMETER	SYMBOL	MIN.	TYP.	MAX.	UNIT
Input Frequency	fCLKin	-	16.9344	-	MHz
Multiplier/Divider Ratio	N/M	-	0.333	-	Multiplier
PLL Output Frequency	fQ0	-	5.6448	-	MHz

XC25BS7008xx (256 multiplication)

PARAMETER	SYMBOL	MIN.	TYP.	MAX.	UNIT
Input Frequency	fCLKin	-	44.000	-	kHz
Multiplier/Divider Ratio	N/M	-	256	-	Multiplier
PLL Output Frequency	fQ0	-	11.264	-	MHz

XC25BS7012xx (256 multiplication)

PARAMETER	SYMBOL	MIN.	TYP.	MAX.	UNIT
Input Frequency	fCLKin	-	92.000	-	kHz
Multiplier/Divider Ratio	N/M	-	256	-	Multiplier
PLL Output Frequency	fQ0	-	23.552	-	MHz

XC25BS7013xx (128 multiplication)

PARAMETER	SYMBOL	MIN.	TYP.	MAX.	UNIT
Input Frequency	fCLKin	-	184.000	-	kHz
Multiplier/Divider Ratio	N/M	-	128	-	Multiplier
PLL Output Frequency	fQ0	-	23.552	-	MHz

## ELECTRICAL CHARACTERISTICS (Continued)

Recommended Operating Conditions: XC25BS7001xx (256 multiplication, Input 48kHz (TYP.)) 3.3V (TYP.)

Tested below Ta=25°C

PARAMETER	SYMBOL	CONDITIONS	MIN.	MAX.	UNIT
Supply Voltage	V <sub>DD</sub>	3.3V (TYP.) operation	2.97	3.63	V
Input Frequency	f <sub>CLKin</sub>	( <sup>*1</sup> )	45.000	60.000	kHz
Multiplier/Divider Ratio	N/M	Typical value is shown ( <sup>*1</sup> )	256		-
Output Frequency	f <sub>Q0</sub>	( <sup>*1</sup> )	11.520	15.360	MHz
Capacity Overload ( <sup>*3</sup> )	CL		-	15	pF
Output Start Time ( <sup>*2</sup> )( <sup>*3</sup> )	T <sub>ON</sub>	f <sub>CLKin</sub> =45kHz	0.05	20	ms

NOTE:

\*1: Connected C<sub>IN</sub>=0.1 μ F of a ceramic capacitor between the V<sub>DD</sub> pin the V<sub>SS</sub> pin while testing.

\*2: Time until signal via the Q0 pin flows stably from applying supply voltage to the V<sub>DD</sub> pin and control voltage to the CE pin while applying the input signal to the CLKin pin.

\*3: The value indicated at output start time is designed values which are not guaranteed values.

DC Characteristics: XC25BS7001xx (256 multiplication, Input 48kHz (TYP.)) 3.3V (TYP.)

Test Conditions: V<sub>DD</sub>=3.3V, f<sub>CLKin</sub>=48kHz, Multiplier ratio=256, Ta=25 , No Load

PARAMETER	SYMBOL	CONDITIONS	MIN.	TYP.	MAX.	UNIT	CIRCUIT
H Level Input Voltage	V <sub>IH</sub>		2.70	-	-	V	①
L Level Input Voltage	V <sub>IL</sub>		-	-	0.60	V	①
H Level Input Current	I <sub>IH</sub>	V <sub>CLKin</sub> =V <sub>DD</sub> -0.3V	-	-	3.0	μ A	②
L Level Input Current	I <sub>IL</sub>	V <sub>CLKin</sub> =0.3V	-3.0	-	-	μ A	②
H Level Output Voltage	V <sub>OH</sub>	V <sub>DD</sub> =2.97V, I <sub>OH</sub> =-4mA	2.50	-	-	V	③
L Level Output Voltage	V <sub>OL</sub>	V <sub>DD</sub> =2.97V, I <sub>OL</sub> = 4mA	-	-	0.40	V	③
Supply Current 1	I <sub>DD1</sub>	V <sub>DD</sub> =3.63V, CE= 3.63V	-	3.0	6.0	mA	④
Supply Current 2	I <sub>DD2</sub>	V <sub>DD</sub> =3.63V, CE= 0.0V	-	-	10	μ A	④
CE H Level Voltage	V <sub>CEH</sub>		2.70	-	-	V	①
CE L Level Voltage	V <sub>CEL</sub>		-	-	0.45	V	①
CE Pull-Down Resistance 1	R <sub>dn1</sub>	CE=V <sub>DD</sub>	0.2	1.0	1.8	MΩ	⑤
CE Pull-Down Resistance 2	R <sub>dn2</sub>	CE=0.1 x V <sub>DD</sub>	10	30	60	kΩ	⑤
Output Off Leak Current	I <sub>OZ</sub>	V <sub>DD</sub> =Q0=3.63V, CE= 0.0V	-	-	10	μ A	⑥

AC Characteristics: XC25BS7001xx (256 multiplication, Input 48kHz (TYP.)) 3.3V (TYP.)

Test Conditions: V<sub>DD</sub>=3.3V, f<sub>CLKin</sub>=48kHz, Multiplier ratio=256, Ta=25 , CL=15pF

PARAMETER	SYMBOL	CONDITIONS	MIN.	TYP.	MAX.	UNIT	CIRCUIT
Output Rise Time ( <sup>*1</sup> )	T <sub>r</sub>	(20% ~ 80%)	-	2.5	5.0	ns	①
Output Fall Time ( <sup>*1</sup> )	T <sub>f</sub>	(20% ~ 80%)	-	2.5	5.0	ns	①
Output Signal Duty ( <sup>*1</sup> )	Duty	f <sub>Q0</sub> ≤ 60MHz	45	50	55	%	①
		f <sub>Q0</sub> ≥ 60MHz	40	50	60	%	
PLL Output Signal Jitter 1 ( <sup>*1</sup> )	T <sub>J1</sub>	1σ (Output Period)	-	20	-	ps	①
PLL Output Signal Jitter 2 ( <sup>*1</sup> )	T <sub>J2</sub>	Peak to Peak (Output Tracking)	-	20	-	ns	①

NOTE:

\*1: Values indicated at the AC Characteristics are designing values, which are not guaranteed values.

## NOTE ON USE

- (1) Please use this IC within the stated absolute maximum ratings. The IC is liable to malfunction should the ratings be exceeded.
- (2) The series is an analog IC. Please use a 0.01  $\mu$ F to 0.1  $\mu$ F of a by-pass capacitor.
- (3) Rq0 shown in the Typical Application Circuit is a matching resistor. The use is recommended in order to counter unwanted radiations.
- (4) Please place the by-pass capacitor and the matching resistor as close to the IC as possible. The IC may not operate normally if the by-pass capacitor is not close enough to the IC. Further, the unwanted radiation may occur between the resistor and the IC pin if the matching resistor is not close enough to the IC.
- (5) When the CE pin is not controlled by external signals, it is recommended that a time constant circuit of  $R1=1k \times C1 = 0.1 \mu F$  be added for stability.
- (6) With this IC, output is achieved by dividing and multiplying the reference oscillation by means of the PLL circuit. In cases where this output is further used as a reference oscillation of another PLL circuit, it may be that the final output signal's jitter increases; therefore, all necessary precautions should be taken to avoid this.
- (7) It is recommended that a low noise power supply, such as a series regulator, be used as the series' supply voltage. Using a power supply such as a switching regulator may enlarge the jitter, which in turn may lead to abnormal operation. Please confirm its operation with the actual device.
- (8) For operating the IC normally, please take procedures below when applying voltage to the series' input pin:
  - 1) Apply power source while the CE pin is "L" level with no clock input (high-Impedance or "L"),
  - 2) Input the clock,
  - 3) At least 100  $\mu$ s after applying clock input, change the CE pin into "H" level and then to enable.The IC has to be started by inputting the clock once the power rises completely. The CE pin, then, should be enabling. If the CE pin becomes enable and the clock is inputted before the power rises completely, an internal reset circuit does not operate normally which may cause to generate extraneous frequency.
- (9) As for this IC, synchronization of input and output signals occurs at the rising edge.

## TEST CIRCUIT

Operating Supply Voltage  
 H Level Input Voltage  
 L Level Input Voltage  
 CE "H" Level Voltage  
 CE "L" Level Voltage  
 Output Rise Time  
 Output Fall Time  
 Output Signal Duty  
 PLL Output Signal Jitter

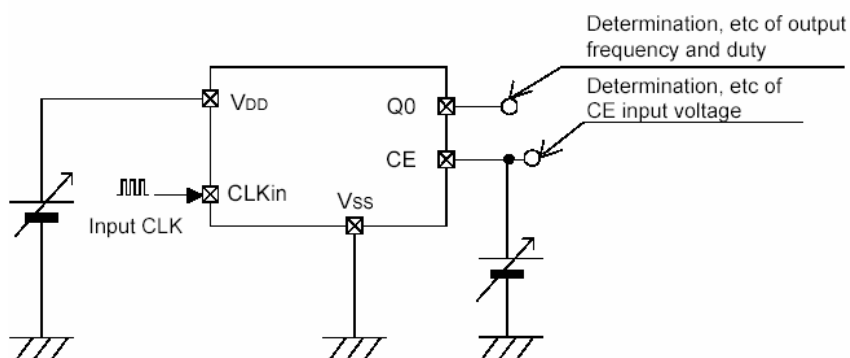

H Level Input Current  
 L Level Input Current

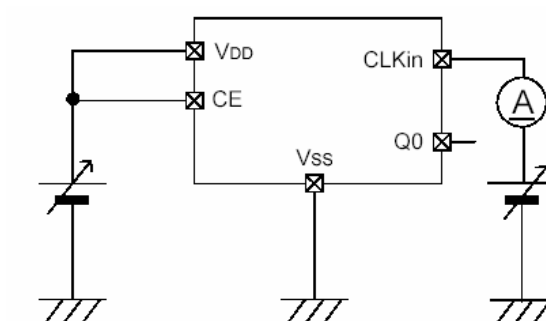

H Level Output Voltage  
 L Level Output Voltage

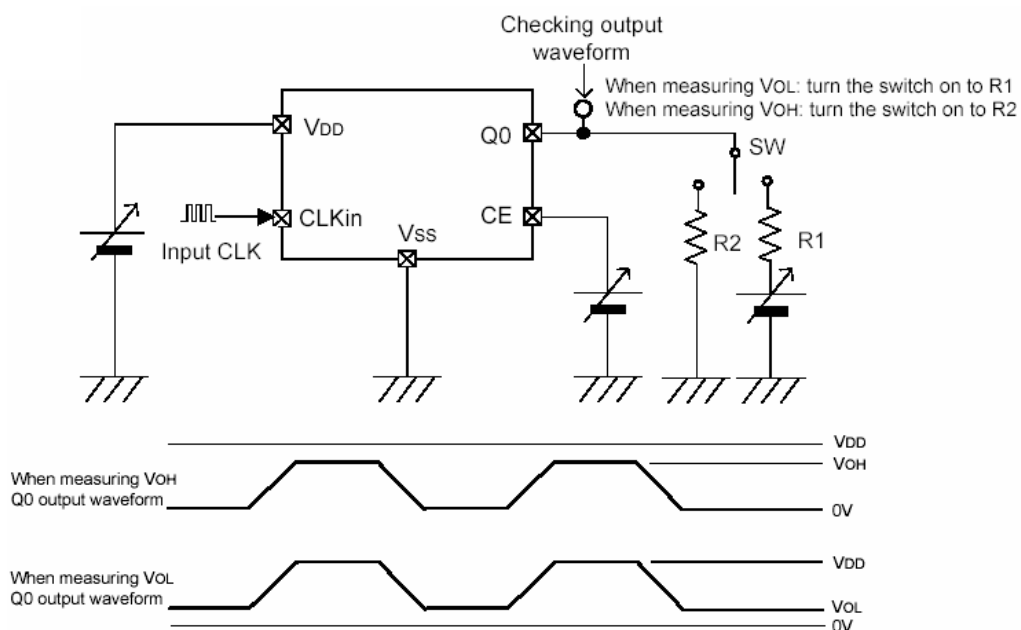

## TEST CIRCUIT (Continued)

Supply Current 1

Supply Current 2

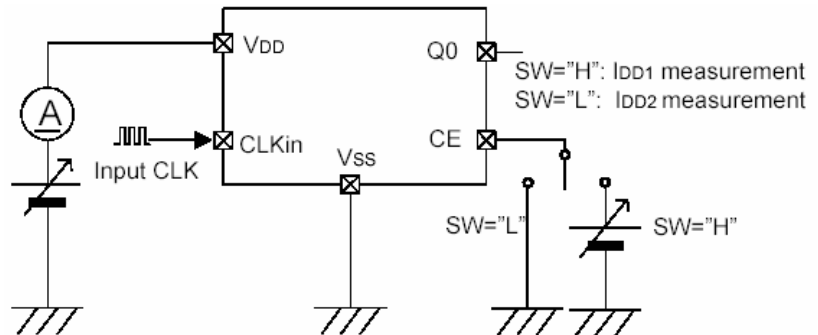

CE Pull-Down Resistance 1

CE Pull-Down Resistance 2

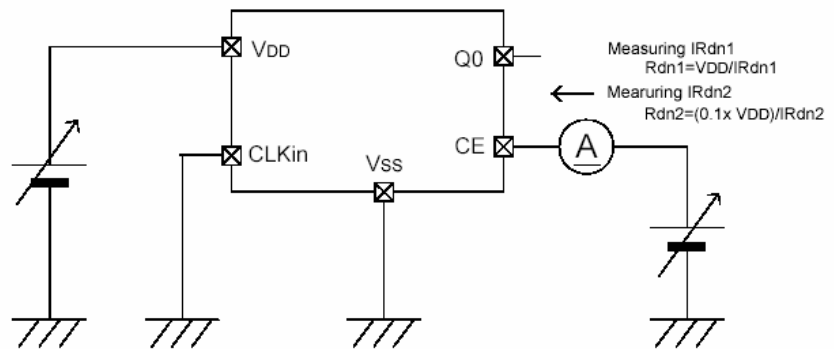

Output Off Leak Current

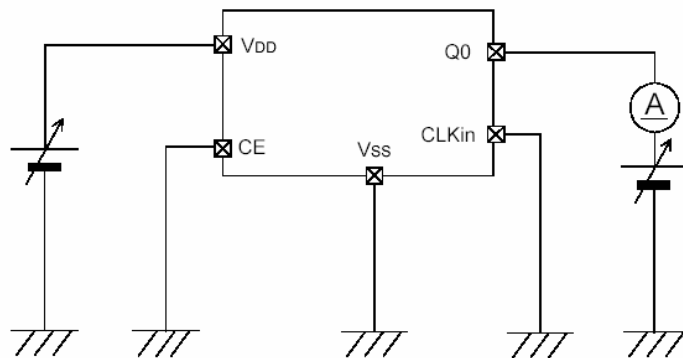



## AC CHARACTERISTICS TEST WAVEFORM

### 1) Output Rise Time, Output Fall Time

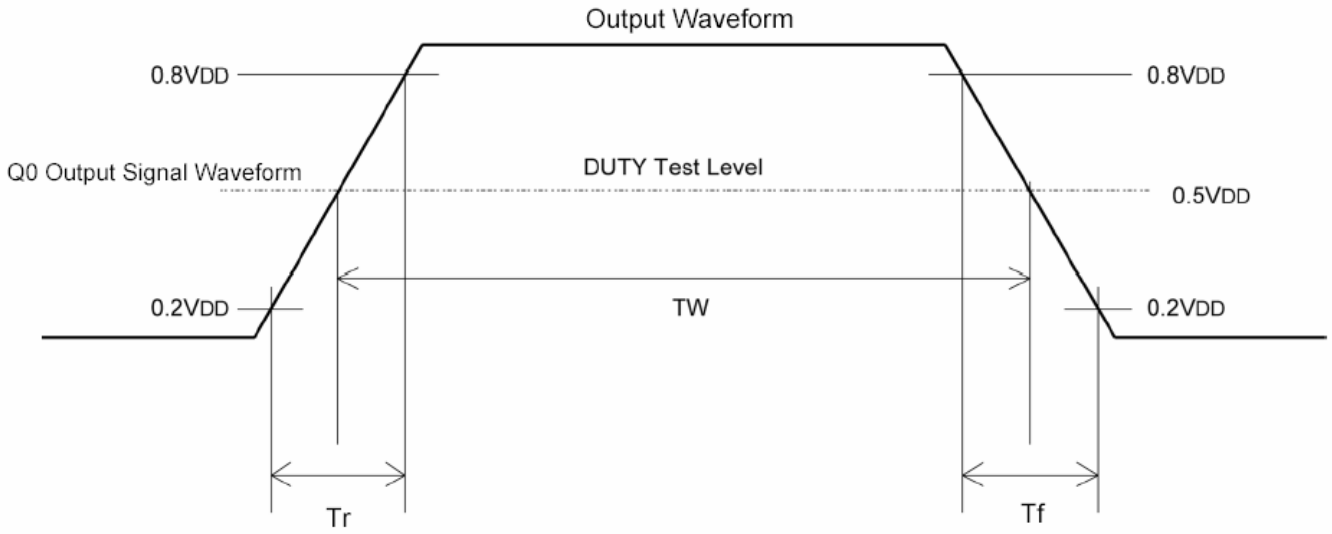

### 2) Duty Ratio

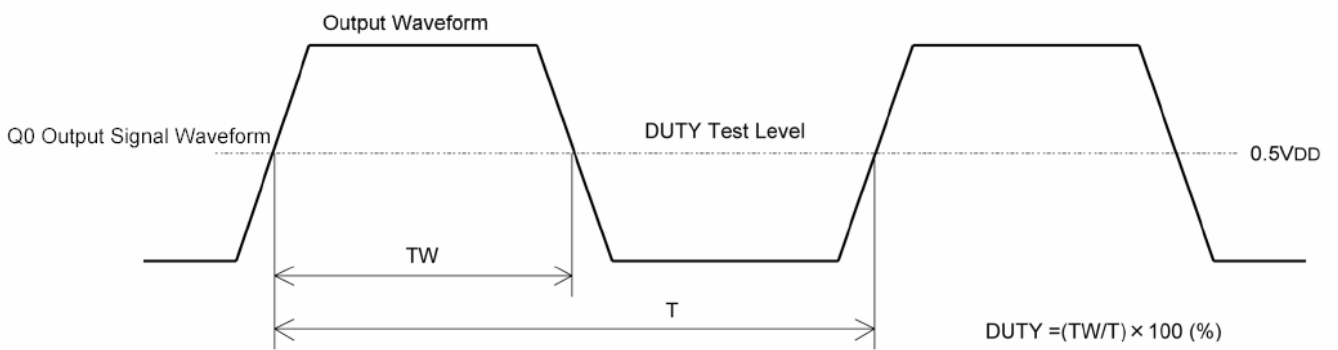

### 3) Output Start Time

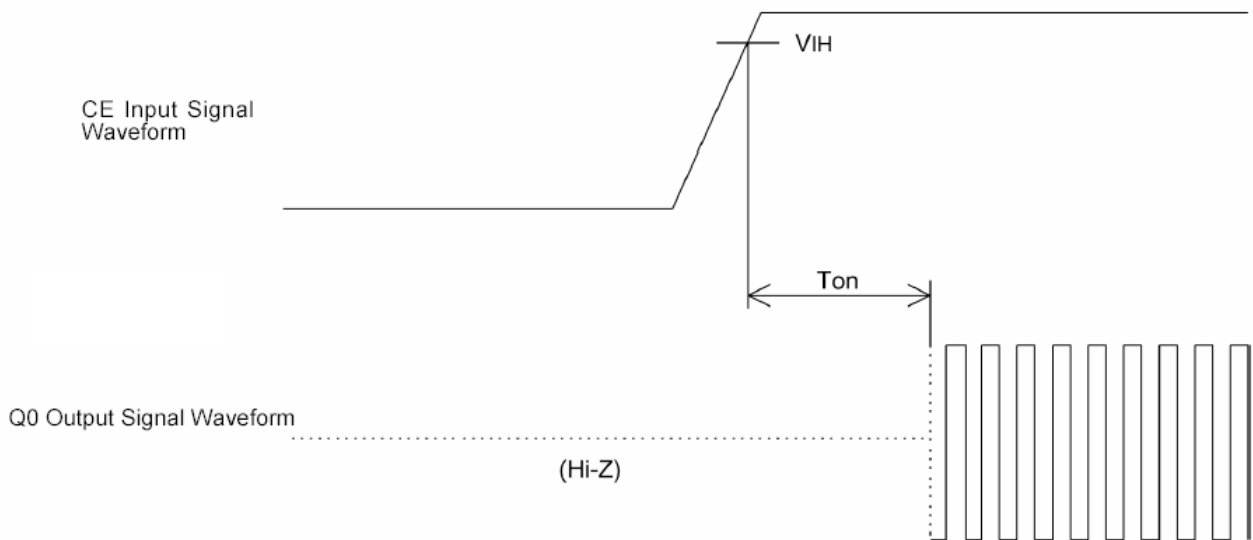

## TYPICAL PERFORMANCE CHARACTERISTICS

Output Frequency Range (Capable of Synchronous) vs. Supply Voltage

XC25BS7001xx (256 multiplication, Input 48kHz (TYP.))

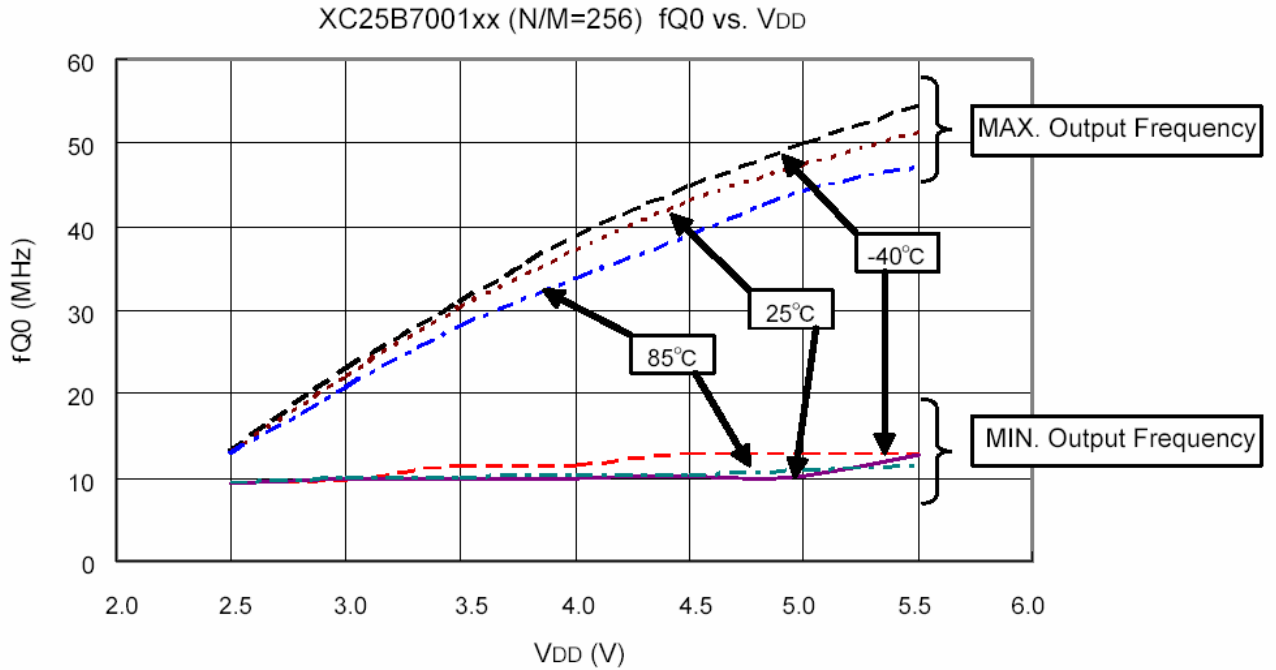

## PACKAGE INFORMATION

SOT-25

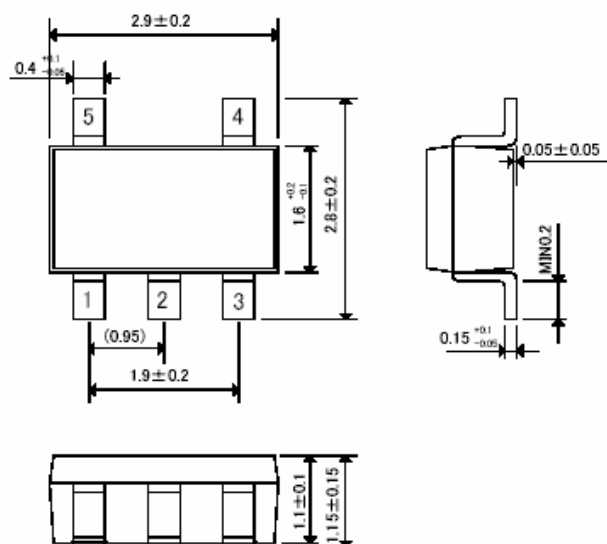

USP-6C

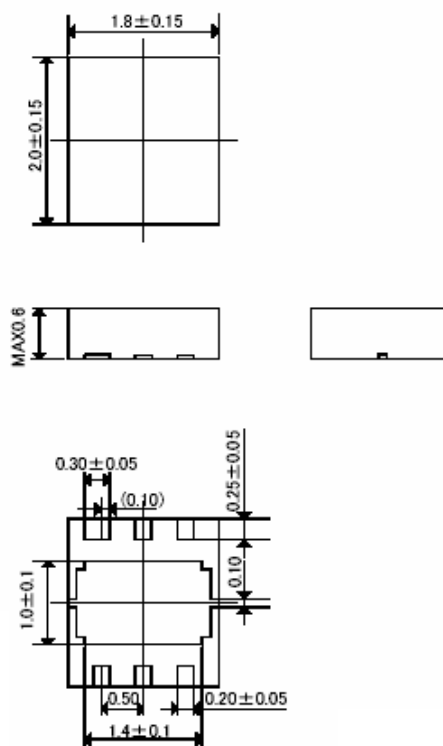

\* No. 1 pin is larger than the other pins.  
Soldering fillet surface is not formed because the sides of the pins are not plated.

USP-6C Recommended Mount Pattern

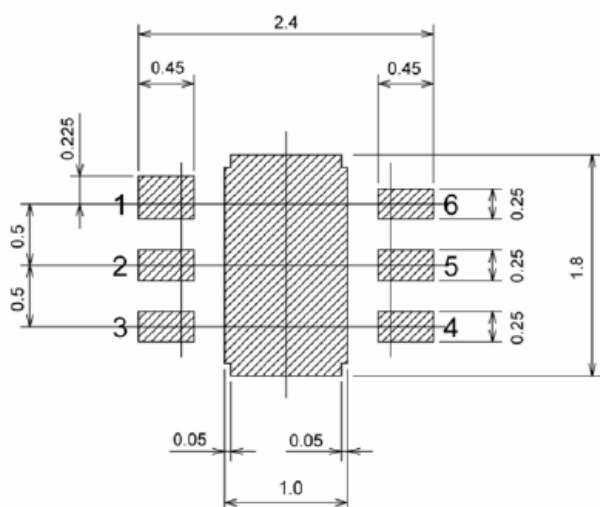

USP-6C Recommended Metal Masking

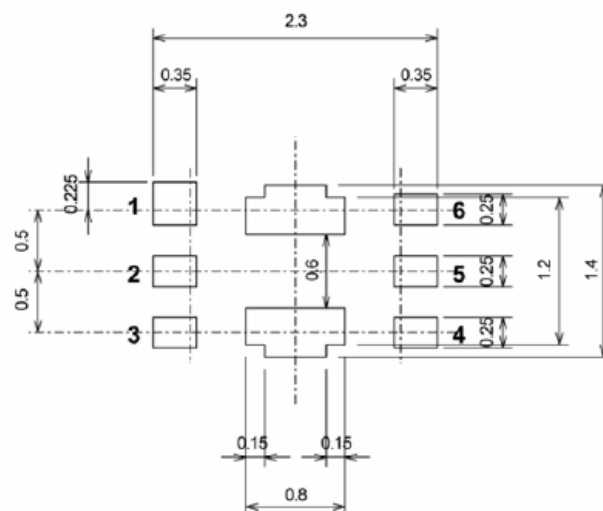

## MARKING RULE

SOT-25

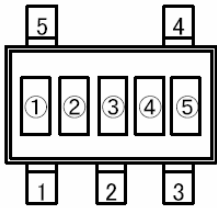

SOT-25  
(TOP VIEW)

Represent product series (Fixed number)

MARK	PRODUCT SERIES
7 (Fixed)	XC25BS70xxMx

, Represents serial number corresponding to part number  
\* 99 sorts of number are repeated as shown below.

MARK	MARK	PRODUCT SERIES	MARK	MARK	PRODUCT SERIES
0	1	XC25BS7x01Mx	1	7	XC25BS7x17Mx
0	2	XC25BS7x02Mx	1	8	XC25BS7x18Mx
0	3	XC25BS7x03Mx	1	9	XC25BS7x19Mx
0	4	XC25BS7x04Mx	2	0	XC25BS7x20Mx
0	5	XC25BS7x05Mx	2	1	XC25BS7x21Mx
0	6	XC25BS7x06Mx	2	2	XC25BS7x22Mx
0	7	XC25BS7x07Mx	2	3	XC25BS7x23Mx
0	8	XC25BS7x08Mx	2	4	XC25BS7x24Mx
0	9	XC25BS7x09Mx	2	5	XC25BS7x25Mx
1	0	XC25BS7x10Mx	2	6	XC25BS7x26Mx
1	1	XC25BS7x11Mx	2	7	XC25BS7x27Mx
1	2	XC25BS7x12Mx	2	8	XC25BS7x28Mx
1	3	XC25BS7x13Mx	2	9	XC25BS7x29Mx
1	4	XC25BS7x14Mx	3	0	XC25BS7x30Mx
1	5	XC25BS7x15Mx	3	1	XC25BS7x31Mx
1	6	XC25BS7x16Mx	:	:	:

, Represents production lot number  
0~9, A~Z and inverted 0~9, A~Z repeated.  
(G, I, J, O, Q, W excepted.)

USP-6C

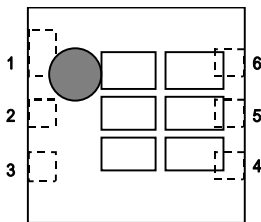

USP-6C  
(TOP VIEW)

Represents product series (Fixed number)

MARK	PRODUCT SERIES
B (Fixed)	XC25BS70xxEx

Represent product series (Fixed)

MARK	PRODUCT SERIES
7 (Fixed)	XC25BS70xxEx

, Represents serial numbers and letters (1 ~ Z) corresponding to part number  
\* 99 sorts of number are repeated as shown in and marking rule of the SOT-25 package.

MARK	MARK	PRODUCT SERIES
0	1	XC25BS7001E*
0	2	XC25BS7002E*

, Represents production lot number  
0 ~ 9, A ~ Z repeated (G, I, J, O, Q, W excepted)  
\* No character inversion used.

1. The products and product specifications contained herein are subject to change without notice to improve performance characteristics. Consult us, or our representatives before use, to confirm that the information in this catalog is up to date.
2. We assume no responsibility for any infringement of patents, patent rights, or other rights arising from the use of any information and circuitry in this catalog.
3. Please ensure suitable shipping controls (including fail-safe designs and aging protection) are in force for equipment employing products listed in this catalog.
4. The products in this catalog are not developed, designed, or approved for use with such equipment whose failure or malfunction can be reasonably expected to directly endanger the life of, or cause significant injury to, the user.  
(e.g. Atomic energy; aerospace; transport; combustion and associated safety equipment thereof.)
5. Please use the products listed in this catalog within the specified ranges.  
Should you wish to use the products under conditions exceeding the specifications, please consult us or our representatives.
6. We assume no responsibility for damage or loss due to abnormal use.
7. All rights reserved. No part of this catalog may be copied or reproduced without the prior permission of Torex Semiconductor Ltd.

**TOREX SEMICONDUCTOR LTD.**

Компания «Океан Электроники» предлагает заключение долгосрочных отношений при поставках импортных электронных компонентов на взаимовыгодных условиях!

Наши преимущества:

- Поставка оригинальных импортных электронных компонентов напрямую с производств Америки, Европы и Азии, а так же с крупнейших складов мира;
- Широкая линейка поставок активных и пассивных импортных электронных компонентов (более 30 млн. наименований);
- Поставка сложных, дефицитных, либо снятых с производства позиций;
- Оперативные сроки поставки под заказ (от 5 рабочих дней);
- Экспресс доставка в любую точку России;
- Помощь Конструкторского Отдела и консультации квалифицированных инженеров;
- Техническая поддержка проекта, помощь в подборе аналогов, поставка прототипов;
- Поставка электронных компонентов под контролем ВП;
- Система менеджмента качества сертифицирована по Международному стандарту ISO 9001;
- При необходимости вся продукция военного и аэрокосмического назначения проходит испытания и сертификацию в лаборатории (по согласованию с заказчиком);
- Поставка специализированных компонентов военного и аэрокосмического уровня качества (Xilinx, Altera, Analog Devices, Intersil, Interpoint, Microsemi, Actel, Aeroflex, Peregrine, VPT, Syfer, Eurofarad, Texas Instruments, MS Kennedy, Miteq, Cobham, E2V, MA-COM, Hittite, Mini-Circuits, General Dynamics и др.);

Компания «Океан Электроники» является официальным дистрибьютором и эксклюзивным представителем в России одного из крупнейших производителей разъемов военного и аэрокосмического назначения «JONHON», а так же официальным дистрибьютором и эксклюзивным представителем в России производителя высокотехнологичных и надежных решений для передачи СВЧ сигналов «FORSTAR».



## JONHON

«JONHON» (основан в 1970 г.)

Разъемы специального, военного и аэрокосмического назначения:

(Применяются в военной, авиационной, аэрокосмической, морской, железнодорожной, горно- и нефтедобывающей отраслях промышленности)

«FORSTAR» (основан в 1998 г.)

ВЧ соединители, коаксиальные кабели,  
кабельные сборки и микроволновые компоненты:

(Применяются в телекоммуникациях гражданского и специального назначения, в средствах связи, РЛС, а так же военной, авиационной и аэрокосмической отраслях промышленности).



Телефон: 8 (812) 309-75-97 (многоканальный)

Факс: 8 (812) 320-03-32

Электронная почта: [ocean@oceanchips.ru](mailto:ocean@oceanchips.ru)

Web: <http://oceanchips.ru/>

Адрес: 198099, г. Санкт-Петербург, ул. Калинина, д. 2, корп. 4, лит. А