

Serial-interfaced 6-digit LED controller with keyscan

Features

- LED driver with 14 outputs (8 segments/6 digits)
- 40 mA load current capability for each segment
- Output pins connected directly to the LEDs or can be open-drain
- Key-scanning (8 x 2 matrix)
- Low power consumption in standby mode
- 3-wire serial bus interface (CLK, STB, DIN/DOUT)
- 8-step dimming circuit to control the overall display brightness
- Single external resistor for output current setting
- Inputs with Schmitt trigger give superior noise immunity
- A single LED digit output (DIG1_LED) can be used to drive up to 8 discrete LEDs
- 8-step dimming circuit to control brightness of individual LEDs for LED digit
- 5.0 V ($\pm 10\%$) for V_{CC}
- Drives common-anode LED digits
- Built-in power on reset and soft-start circuits
- Available in SO24 package
- $-40\text{ }^{\circ}\text{C}$ to $85\text{ }^{\circ}\text{C}$ operating temperature range

Applications

- Set-top-boxes
- White goods
- Home appliances
- DVD players and VCRs

Table 1. Device summary

Part number	Package	Packaging
STLED316SMTR	SO-24	Tape and reel

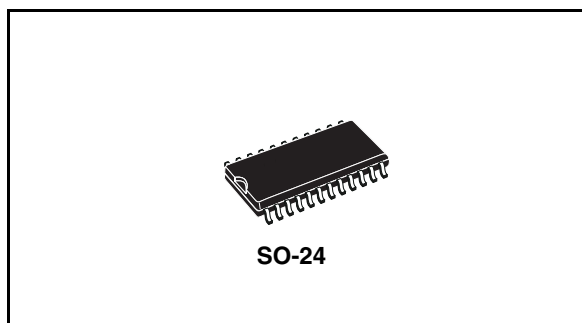

Description

The STLED316S is a compact LED controller and driver that interface microprocessors to LED displays through a serial 3-wire interface. It drives LED connected in common anode configuration. The STLED316S drives up to 48 discrete LEDs in 8 segment/6 digit configuration while functioning from a supply voltage of 5.0V. Additionally it can be used to drive 8 discrete LEDs which form a part of LED digit. The individual LEDs are wired as segments of a digit and brightness of these individual LEDs can be controlled digitally. The maximum segment current for the display digits is set through a single external resistor. Individual digits may be addressed and updated without re-writing the entire display.

Additionally it includes key scanning for an 8x2 key matrix which automatically scans a matrix of up to 16 switches. STLED316S supports numeric-type displays and reduces the overall BOM costs through high integration. Also it provides ESD protection of greater than 4 kV HBM.

The LED controller/driver is ideal as a peripheral device to interface the display with a singlechip microcomputer.

Contents

- 1 STLED316S functional and application diagram 3**
- 2 Pin description 5**
- 3 STLED316S functional description 7**
 - 3.1 Low power mode of operation 7
 - 3.2 Serial interface 7
 - 3.3 Initial power up 7
 - 3.4 Display types 8
 - 3.5 Keyscan 8
 - 3.6 Discrete LED outputs 8
 - 3.7 Power on reset and soft-start 8
 - 3.8 LED drivers 9
 - 3.9 Interrupt 9
 - 3.10 Operating the device with 3.3 V interface voltages 9
- 4 Maximum rating 10**
 - 4.1 Thermal data 10
- 5 Recommended operating conditions 11**
 - 5.1 DC electrical characteristics 11
 - 5.2 Power consumption estimation 12
 - 5.3 Capacitance 12
 - 5.4 Power supply characteristics 12
 - 5.5 Dynamic switching characteristics 13
 - 5.6 Timing characteristics 13
 - 5.7 ESD performance 13
- 6 Key-scan & display cycle 14**
- 7 Key matrix and key-input data storage ram 15**
- 8 Commands 16**

8.1	Write command	16
8.2	Read command	17
8.3	Device configuration	18
8.3.1	Display setting (maximum number of digits):	19
8.3.2	Dimming setting (brightness levels):	19
8.4	Display memory	20
9	Key-scanning and display timing	22
9.1	Serial communication format (reception)	23
9.2	Serial communication format (transmission)	24
10	Switching characteristics waveform	25
11	Application information	26
11.1	Graph of ISET against RSET	26
11.2	Power supply sequencing	27
11.3	Application diagram	27
12	Package mechanical data	28
13	Revision history	29

List of figures

Figure 1.	STLED316S functional diagram	5
Figure 2.	STLED316S application diagram	6
Figure 3.	STLED316S pin connection	7
Figure 4.	Key matrix.	17
Figure 5.	Serial communication format (reception)	25
Figure 6.	Serial communication format (transmission).	26
Figure 7.	Switching characteristics waveform	27
Figure 8.	Graph of ISET against RSET	28
Figure 9.	STLED316S application diagram	29
Figure 10.	SO-24 package outline	30

List of tables

Table 1.	Device summary	1
Table 2.	Pin description	8
Table 3.	Seven segment display with dot point and common-anode LED panel	11
Table 4.	Absolute maximum ratings (all voltages are referenced to GND).	13
Table 5.	Thermal data.	13
Table 6.	DC electrical characteristics ($T_A = -40$ to $+85$ °C, $V_{CC} = 5.0$ V \pm 10%, GND = 0 V)	14
Table 7.	Capacitance ($T_A = 25$ °C, $f = 1$ MHz)	15
Table 8.	Power supply characteristics ($T_A = -40$ to $+85$ °C).	15
Table 9.	Dynamic switching characteristics ($T_A = -40$ to $+85$ °C, $V_{CC} = 5.0$ V \pm 10%, GND = 0.0 V, typical values are at 25 °C)	16
Table 10.	Timing characteristics ($T_A = -40$ to $+85$ °C, $V_{CC} = 5.0$ V \pm 10%, GND = 0.0 V, Typical values are at 25 °C)	16
Table 11.	ESD performance	16
Table 12.	Read command	20
Table 13.	Memory page mapping	21
Table 14.	Digit address mapping	21
Table 15.	LED address mapping	22
Table 16.	Memory page address	23
Table 17.	7-segment display address.	23
Table 18.	LED display address.	23
Table 19.	Part list	30
Table 20.	SO-24 package mechanical data	31
Table 21.	Document revision history	32

1 STLED316S functional and application diagram

The STLED 316S consists of the following blocks:

- Current source
- POR and soft-start
- Interrupt generator
- Serial interface
- Digital logic blocks
- Drivers

Figure 1. STLED316S functional diagram

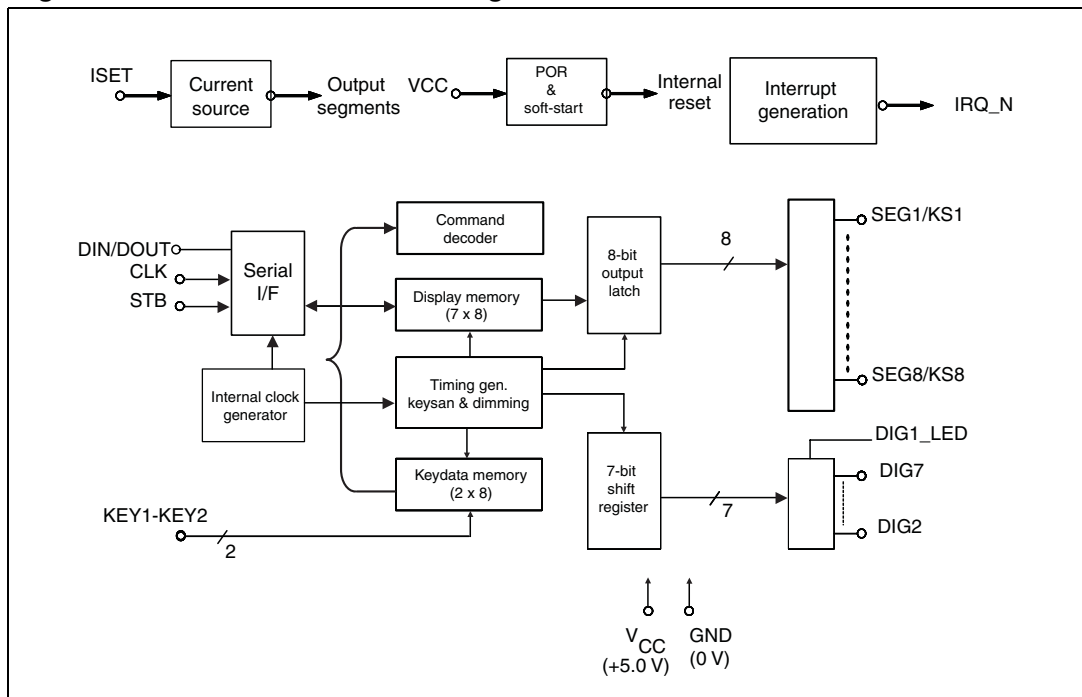
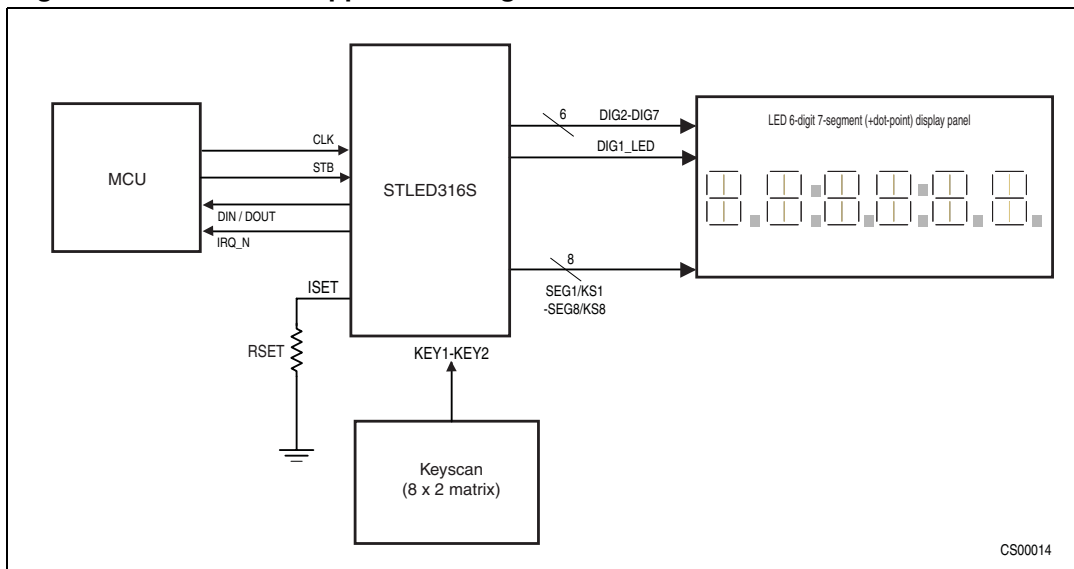

Figure 2. STLED316S application diagram



2 Pin description

Figure 3. STLED316S pin connection

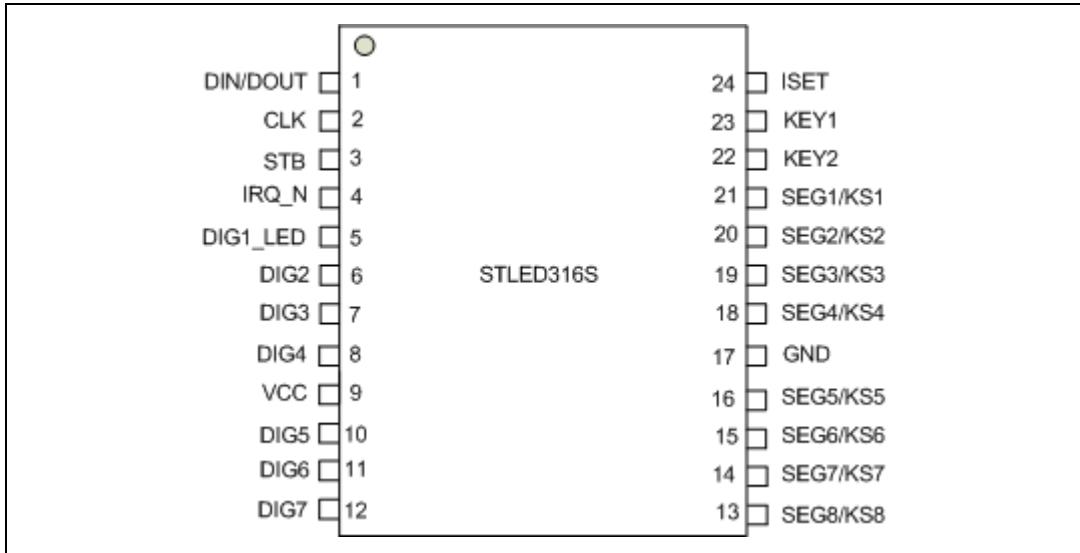

Table 2. Pin description

Pin number	Symbol	Type	Name and function
1	DIN/DOUT	IN/OUT	Output serial data at falling edge of the shift clock, starting from lower bit. Input serial data is clocked in at rising edge of the shift clock, starting from lower bit.
2	CLK	IN	Reads serial data at rising edge, and outputs data at falling edge.
3	STB	IN	Initializes serial interface at rising or falling edge to make STLED316S wait for reception of command. Data input after the falling edge of STB are processed as a command. While command data are processed, current processing is stopped, and the serial interface is initialized. While STB is high, instructions are ignored.
4	IRQ_N	OUT	Interrupt output (active low) to interrupt the MCU when there is a key press
5	DIG1_LED	OUT	Single output LED used together with the 8 segments to drive up to 8 discrete LEDs
6,7,8	DIG2, DIG3, DIG4	OUT	Digit output pins.
9	V _{CC}	PWR	5.0 V ± 10% Core main supply voltage. Bypass to GND through a 0.1 μF capacitor as close to the pin as possible.
10,11,12	DIG5, DIG6, DIG7	OUT	Digit output pins.

Table 2. Pin description (continued)

Pin number	Symbol	Type	Name and function
13,14,15,16	SEG8/KS8 to SEG5/KS5	OUT	Segment output pins (dual function as key source).
17	GND	PWR	Connect this pin to system GND.
18,19,20,21	SEG4/KS4 to SEG1/KS1	OUT	Segment output pins (dual function as key source).
22	KEY2	IN	Key 2 input. Input data to these pins from external keyboard are latched at end of the display cycle (maximum keyboard size is 8 x 2).
23	KEY1	IN	Key 1 input. Input data to these pins from external keyboard are latched at end of the display cycle (maximum keyboard size is 8 x 2).
24	ISET	IN	Segment current setting. Connect to GND through a resistor to set the peak segment current.

3 STLED316S functional description

The STLED316S is a common-anode LED driver controller which can be used to drive red, green or blue LEDs as the current is adjustable through the external resistor. In the common anode configuration, the segment outputs sink the current from the cathodes while the digit outputs source the current to the anodes. The configurable output current can be used to drive LEDs with different current ratings (red, green or blue). The brightness of the whole display can be controlled through the serial interface as described later. The outputs can be connected together in parallel to drive a single LED. In this case, two parallel current sources of equal value drive a single LED. The external resistor value can be set accordingly to determine the desired output current thus controlling the display brightness.

Soft-start limits the inrush current during power-up. The display is blanked (LEDs are turned off or in high-Z state) on power-up.

3.1 Low power mode of operation

Upon initial power up or when not configured or when not used, the STLED316S will be in low power mode of operation wherein the current consumption drops to less than 1mA. During this mode, the data configured is maintained as long as the supply voltage is still present (the contents of the internal RAM need the supply voltage to be present). Port configuration and output levels are restored when the STLED316S resumes normal operation. For minimum supply current in shutdown mode, logic inputs should be at GND or V_{CC} .

3.2 Serial interface

The interface is used to write configuration and display data to the STLED316S. The serial interface comprises of a shift register into which DIN is clocked on the rising edge of the CLK when STB is low. When STB is low, falling transitions on CLK clock the data from the device to the microcontroller. The 8-bit data is decoded to determine and execute the command.

STB indicates to the device the start of communication when it goes low. DIN/DOUT pin is bi-directional. The data will be validated during positive pulse of the clock in both write/read modes. If the STB signal goes high before completing the data byte write to the device, the preceding data bits are ignored and the previous configuration remains intact.

3.3 Initial power up

On initial power-up, all control registers are reset, the display is blanked and the STLED316S is in the low power mode. All the outputs are in high-impedance state at initial power-up. The DIN/DOUT is pulled high by an external pull-up resistor. The display driver has to be configured before the display can be used.

3.4 Display types

Table 3. Seven segment display with dot point and common-anode LED panel

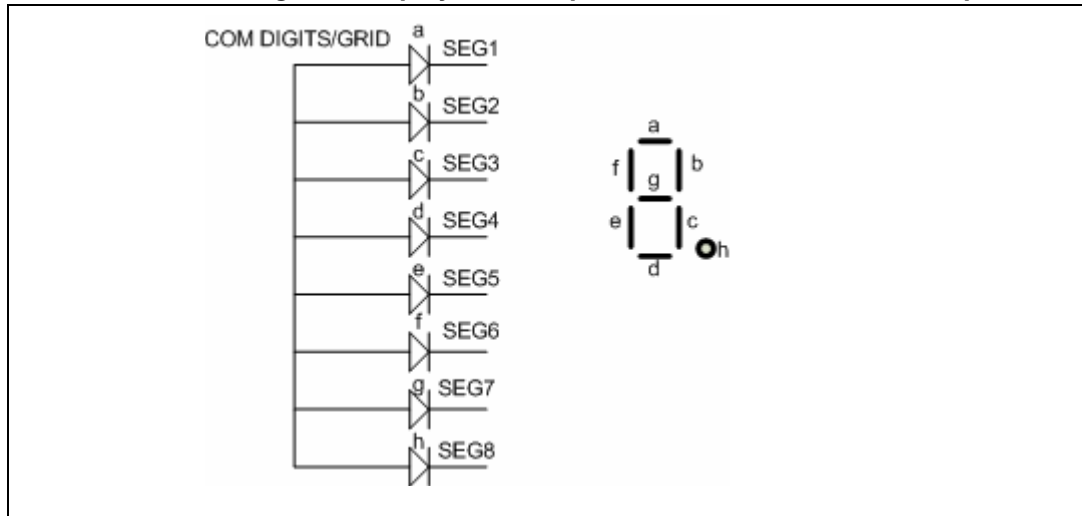

3.5 Keyscan

The full keyscan is illustrated in the another section of the datasheet. One diode is required per key switch. The keyscan circuit detects any combination of keys being pressed.

3.6 Discrete LED outputs

The STLED316S can be used to drive up to 8 discrete LEDs. The single LED output acts like a digit driver output and can be wired-up with 8 segment outputs to drive up to 8 different discrete LEDs. Physical connections from the LED output as well as the segment outputs must be made to drive the discrete LEDs in the desired manner. The discrete LEDs may be needed to indicate the “Power”, “Standby” status (for example). Also it is possible to separately control the brightness of each single LED.

3.7 Power on reset and soft-start

The device integrates an internal power-on-reset circuit which initializes the digital logic upon power up. The soft-start circuit limits the inrush current and high peak current during power-up. This is done by delaying the input circuit’s response to the external applied voltage. During soft-start, the input resistance is higher which lowers the in-rush current when the supply voltage is applied.

3.8 LED drivers

The constant current capability is up to 40 mA per output segment and is set for all the outputs using a single external resistor. When acting as digit drivers, the outputs source current to the display anodes. When acting as segment drivers, the LED outputs sink current from the display cathodes. The outputs are high impedance when not being used as digit or segment drivers.

Each port configured as a LED digit driver behaves as a digitally-controlled constant current sink. The LED drivers are suitable for both discrete LEDs and common anode (CA) numeric LED digits. When fully configured as a LED driver, the STLED316S controls up to 8 LED segments in a single digit with 8-step logarithmic brightness control for the digits. A single resistor sets the maximum segment current for all the segments, with a maximum of 40mA per segment. The STLED316S drives any combination of discrete LEDs and CA digits for numeric displays.

The recommended value of R_{SET} is the minimum allowed value, since it sets the display driver to the maximum allowed segment current. R_{SET} can be a higher value to set the segment current to a lower maximum value where desired. The user must also ensure that the maximum current specifications of the LEDs connected to the drivers are not exceeded.

The brightness of the individual digits in the display panel can be controlled separately.

3.9 Interrupt

The device includes an active low level IRQ_N pin to the microprocessor. The STLED316S generates an interrupt when a key is pressed.

3.10 Operating the device with 3.3 V interface voltages

The device can detect the input voltage levels reference to 3.3 V from the main controller chip as long as the V_{IL} and V_{IH} specifications of the STLED316S are met. If the input voltage to STLED316S is greater than 2.9 V, the STLED316S will recognize the signal level as a valid high and if the input voltage is lower than 1.75 V, it will be recognized as a valid low level.

For the output signals from the device like $DOUT$ and IRQ_N , the signal level depends on the external supply to which the external pull up resistor is connected to. Thus this eliminates the use of any level shifter between the main controller and the STLED316S.

4 Maximum rating

Stressing the device above the rating listed in the “Absolute maximum ratings” table may cause permanent damage to the device. These are stress ratings only and operation of the device at these or any other conditions above those indicated in the operating sections of this specification is not implied. Exposure to absolute maximum rating conditions for extended periods may affect device reliability. Refer also to the STMicroelectronics SURE program and other relevant quality documents.

Table 4. Absolute maximum ratings (all voltages are referenced to GND)

Symbol	Parameters	Values	Unit
V_{CC}	Supply voltage to ground	-0.5 to +7.0	V
V_I	Logic input voltage	-0.5 to $V_{CC}+0.5$	V
P_D	Power dissipation ⁽¹⁾	1200	mW
T_A	Operating ambient temperature	-40 to 85	°C
T_J	Junction temperature	150	°C
T_{STG}	Storage temperature	-65 to +150	°C
T_L	Lead temperature (10 sec)	300	°C
V_{ESD}	Electrostatic discharge voltage on all pins ⁽²⁾ Human body model	-4 to +4	kV

1. De-rate at -9.6 mW/°C at $T_A = 25^\circ\text{C}$ or higher

2. In accordance with the JEDEC standard

4.1 Thermal data

Table 5. Thermal data

Symbol	Parameter	Min	Typ	Max	Unit
T_{thJC}	Thermal resistance junction-ambient		75		°C/W

5 Recommended operating conditions

5.1 DC electrical characteristics

Table 6. DC electrical characteristics
($T_A = -40$ to $+85$ °C, $V_{CC} = 5.0$ V \pm 10%, GND = 0 V)

Symbol	Parameter	Test conditions	Min	Typ	Max	Unit
V_{CC}	Logic supply voltage		4.5	5.0	5.5	V
V_{IH}	High level input voltage	High level guaranteed digital pins	0.57 V_{CC}		V_{CC}	V
V_{IL}	Low level input voltage	Low level guaranteed digital pins	0		0.3 V_{CC}	V
I_{IH} , I_{IL}	Input current	$V_{IN} = V_{CC}$ or GND	-2		2	μ A
V_{HYS}	Hysteresis voltage (DIN, CLK, STB pins)		0.9	1.05	1.2	V
$V_{OL(DOUT)}$	Low level output voltage	DOUT, $I_{OL2} = 4$ mA			0.4	V
I_{OLEAK}	Driver leakage current	Drivers off			-140	μ A
I_{SEG}	Segment drive LED sink current	$V_{LED} = 2.5$ V $V_{DIGIT} = V_{CC} - 1.0$	-30	-40	-50	mA
I_{DIG}	Digit drive LED source current	$V_{DIGIT} = V_{CC} - 1.0$	240	320	400	mA
I_{TOLSEG}	Segment drive current matching	$V_{CC} = 5.0$ V, $T_A = 25$ °C $V_{LED} = 2.5$ V		3		%
R_{SET}	External current setting reference resistor (precision = \pm 1% tolerance)	$I_{SEG} = 40$ mA		360		Ω

5.2 Power consumption estimation

Each port of the STLED316S can sink a maximum current of 40 mA into an LED with a 4.4 V forward voltage drop when operated from a supply voltage of 5.0 V. The minimum voltage drop across the internal LED drivers is thus $5.0 - 4.4 = 0.6$ V. The STLED316S can sink $8 \times 40 = 320$ mA when all outputs are operating as LED segment drivers at full current. On a 5.0 V supply, a STLED316S dissipates $(5.0 \text{ V} - 4.4 \text{ V}) \times 320 \text{ mA} = 192$ mW when driving 8 of these 4.4 V forward voltage drop LEDs at full current. If the application requires high drive current, consider adding a series resistor to each LED to drop excessive drive voltage off-chip.

If the forward voltage of the LED is lesser than 4.4 V (say 2.4 V), then the maximum power dissipation of STLED316S when all segments are turned on will be $(5 - 2.4) \text{ V} \times 320 \text{ mA} = 832$ mW. To lower the power dissipation, consider adding a small series resistor in the supply. Another alternative is to increase the value of the R_{SET} to lower the current of the LEDs from 40 mA to say 30 or 20 mA.

The efficiency will be the power consumption in the LEDs divided by the input power consumed.

$$\text{Efficiency} = V_{\text{diode}} \times I_{\text{diode}} / V_{\text{CC}} \times I_{\text{CC}}$$

As an example, consider LED with forward voltage of $V_F = 2.4 \text{ V}$, $I_{\text{peak}} = 40 \text{ mA}$, $V_{\text{CC}(\text{max})} = 5.5 \text{ V}$, $N = \text{number of segments} = 8$ (max), $D = \text{duty cycle} = 15/16$,

Power dissipation, $P_{D(\text{max})} = 5 \text{ mA} \times 5.5 \text{ V} + (5.5 - 2.4) \text{ V} \times (15/16) \times 40 \text{ mA} \times 8 = 27.5 + 780 = 807.5$ mW. To lower this value, add a series resistor with the supply.

5.3 Capacitance

Table 7. Capacitance ($T_A = 25 \text{ }^\circ\text{C}$, $f = 1 \text{ MHz}$)

Symbol	Parameter	Test conditions	Min	Typ	Max	Unit
C_{IN}	Input capacitance				15	pF

5.4 Power supply characteristics

Table 8. Power supply characteristics ($T_A = -40$ to $+85 \text{ }^\circ\text{C}$)

Symbol	Parameter	Test conditions	Min.	Typ.	Max.	Unit
I_{STBY}	Quiescent power supply current	$V_{\text{CC}} = 5.5 \text{ V}$, All inputs = V_{CC} or GND		50	1000	μA
I_{CC}	Operating power supply current (display ON)	All segments ON, all digits scanned, intensity set to full, internal oscillator, no display load connected		10	15	mA

5.5 Dynamic switching characteristics

Table 9. Dynamic switching characteristics

($T_A = -40$ to $+85$ °C, $V_{CC} = 5.0$ V \pm 10%, GND = 0.0 V, typical values are at 25 °C)

Symbol	Parameter	Test conditions	Min.	Typ.	Max.	Unit
f_{OSC}	Internal oscillation frequency		400	500	600	kHz
f_{MAX}	Clock (CLK) frequency	Duty = 50%	1			MHz
t_{PLZ}	Propagation delay	CLK to DOUT $R_L = 10$ K Ω , $C_L = 15$ pF			300	ns
t_{PZL}					100	ns

5.6 Timing characteristics

Table 10. Timing characteristics

($T_A = -40$ to $+85$ °C, $V_{CC} = 5.0$ V \pm 10%, GND = 0.0 V, Typical values are at 25 °C)

Symbol	Parameter	Test conditions	Min.	Typ.	Max.	Unit
PW_{CLK}	Clock pulse width		400			ns
PW_{STB}	Strobe pulse width		1			μ s
t_{SETUP}	Data setup time		100			ns
t_{HOLD}	Data hold time		100			ns
$t_{CLK-STB}$	Clock-strobe time	CLK rising edge to STB rising edge	1			μ s

5.7 ESD performance

Table 11. ESD performance

Symbol	Parameter	Test conditions	Min.	Typ.	Max.	Unit
ESD	JEDEC standard (all pins)	HBM		± 4		kV

6 Key-scan & display cycle

The display RAM stores the data transmitted from an external device to the STLED316S through the serial interface. Refer to [Section 9: Key-scanning and display timing on page 25](#) for a pictorial representation.

The grid and segment outputs are controlled by the display output module. The entire grid will be turned off on channel 1/16 and 16/16 meaning that the first channel and last channel are off. This is referred to as blanking time.

During the keyscan time (first cycle from timing generator), the entire grid is turned off and only the segments are enabled one by one (seg0 to seg7). The segment on time is 64 μ s.

During the LED discrete time (second cycle), the data present on the internal LED buffer is checked. If the data is present, then the brightness setting of each LED in the brightness control register is checked. Then each segment will be enabled or disabled based on the register value. In this duration, the grids 1 to 6 are turned off. The grid corresponding to LED digit is turned on. The LED on duty cycle is 14/16. If the LED/seg1 brightness is 12/16, it means that the segment1 OFF time is 12/16 and on time is 2/16.

During 7-segment display time (3rd cycle to 8th cycle), the display status is checked whether it is ON or OFF. If display is ON, then the dimming settings are checked from the configuration register for the grid (it may be common dimming setting or individual dimming setting for each digit). The minimum turn on time is 1/16 and maximum turn on time is 14/16. The blanking time is valid before the turning on and turning off of the grid. The blanking interval is 32 μ s. This will continue until the maximum number of digits configured in the register. Once the full cycle is complete, the keyscan cycle will start again.

If the display is not turned on, then the timing generation will immediately go to the key scan mode.

Initial:

All the segments and grids are turned off.

During operation:

1. Turn on segment (keyscan) one by one. On time duration is 64 μ s.
2. Check the data present in LED register. If data is present, turn on the respective LED grid and segments.
3. Check the display on. If display is turned on, then enable the grid one by one from grid 1 to grid 6 (maximum) and turn on segments.

7 Key matrix and key-input data storage ram

During the key scan cycle all the grids are turned off. The first segments turn on is 64 μ s. The key1 and key2 signals will be sampled after 60 μ s. The two signals latch into the internal key buffer. The same applies for other segments.

This key buffer compares the data with the previous key status. If any changes are seen in the buffer values, then the IRQ_N is asserted. The IRQ_N signal is active low (level). This IRQ_N signal will be cleared at the end of reading the key buffer (end of byte transfer). The key buffer must be completely read before the IRQ_N is cleared.

The key matrix is of 8 x 2 configuration, as shown below:

Figure 4. Key matrix

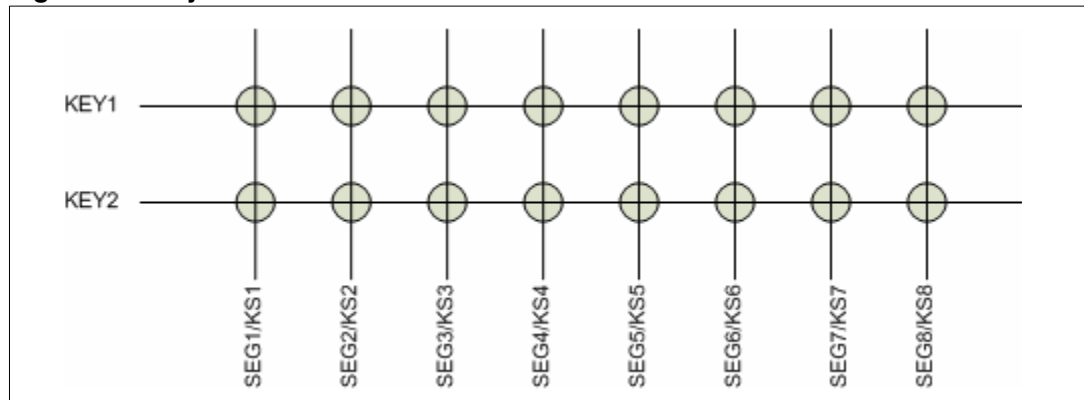

The data of each key are stored as illustrated below, and are read by the appropriate read command, starting from the least significant bit.

1st byte

KEY1	KEY1	KEY1	KEY1	KEY1	KEY1	KEY1	KEY1
SEG1/KS1	SEG2/KS2	SEG3/KS3	SEG4/KS4	SEG5/KS5	SEG6/KS6	SEG7/KS7	SEG8/KS8

LSB MSB

2nd byte

KEY2	KEY2	KEY2	KEY2	KEY2	KEY2	KEY2	KEY2
SEG1/KS1	SEG2/KS2	SEG3/KS3	SEG4/KS4	SEG5/KS5	SEG6/KS6	SEG7/KS7	SEG8/KS8

LSB MSB

The initial key buffer value is “00”. During operation, the buffer values will change depending upon the values of the key-press.

8 Commands

Command sets the display mode and the status of the LED driver. The first byte input to the STLED316S through the DIN input after the STB goes low is regarded as a command. If STB is set high while commands/data are transmitted, serial communication is initialized, and the commands/data being transmitted are invalid (however, the commands/data already transmitted remain valid).

8.1 Write command

MSB 8	MSB 7	MSB6	MSB5	LSB4	LSB3	LSB2	LSB1
-------	-------	------	------	------	------	------	------

Description:

- LSB 3 -1 →address of the memory
- MSB5 and LSB4 →address of memory bank (page)
- MSB →6 '0' auto increment address
 - '1' fixed address
- MSB 7 →0' Write command
 - '1' Read command
- MSB 8 →X' Unused

The following bytes are either configuration data or display data.

During the write command, the control flag display on and auto increment address are latched into the internal control flag register. The default value is '0' for display on control register implying that the display is off. The user must turn on the display to view the display memory. Similarly the auto increment address mode is enabled by default. If the user desires to read from a particular address location, the user can fix the address pointer.

Display on:

MSB 8	MSB 7	MSB6	MSB5	LSB4	LSB3	LSB2	LSB1
x	0	X	0	1	1	0	1

Display off:

MSB 8	MSB 7	MSB6	MSB5	LSB4	LSB3	LSB2	LSB1
x	0	X	0	1	1	1	0

Use these two commands to turn the display 'ON' and 'OFF'.

8.2 Read command

MSB 8	MSB 7	MSB6	MSB5	LSB4	LSB3	LSB2	LSB1
-------	-------	------	------	------	------	------	------

- Description:**
- LSB 3 -1 →address of the memory
 - MSB5 and LSB4 →address of the memory bank (page)
 - MSB 6 →'0' auto increment address
'1' fixed address
 - MSB 7 →'0' Write command
'1' Read command
 - MSB 8 →'X' Unused

Use the page 0x01 to read the LED data and key data.

Table 12. Read command

Address	Function
00	LED data (optional)
01	Key data byte1
02	Key data byte2

Set flag for key1 and key2 to ensure that the user reads from the particular key. When reading the key data from the memory, the IRQ_N will be automatically cleared signifying that the end of the 8th bit was transmitted correctly.

If the IRQ_N is asserted by the last eight keys, then the user reads the key data (one byte only by reading the first byte). In this case, the IRQ_N will remain active until the second byte is read. When the user uses the read key to read the LED and key data, first the user must choose the address (default address location is 0x00) after which the address will increment only by 3 addresses (maximum).

8.3 Device configuration

This section describes how to program and read the configuration of the device. Configuration data comprises of the display setting, dimming setting, display on/off and fixed

address/auto increment. The address pointer will indicate the configuration location and write signal writes the configuration data into the respective location.

The memory block is split into two page locations. One is for the 7-segment brightness configuration memory and the other is for the LED (discrete) configuration memory. The configuration memory address starts from 0x00 to 0x07. The configuration page address is "10" and "11".

Initial Value:

Table 13. Memory page mapping

Memory page	Address	Value
10	00	0xFB
10	01	0x00
10	02	0x00
10	03	0x00
11	00	0x00
11	01	0x00
11	02	0x00
11	03	0x00

Description: Address 0x00; page 0x10
 LSB 0 – 2 → indicates the number of digits in the display
 LSB3 MSB 4 → '11' is for constant brightness control for the display
 → '00' is for variable brightness control for the display
 → '01' is reserved
 → '10' is reserved
 MSB 5 – 7 → indicates constant brightness control value for all including the LED (discrete)

Default is constant brightness control with 14/16 pulse width (for maximum brightness).

Page 0x10 - address 0x01 to 0x03 is for the variable brightness control value for 7 segments:

Table 14. Digit address mapping

Address	MSB	LSB
0x01	Digit 2	Digit 1
0x02	Digit 4	Digit 3
0x03	Digit 6	Digit 5

Default is constant brightness control with 14/16 pulse width.

Page 0x11 - address 0x00 to 0x03 is for the variable brightness control value for LED (discrete)

Table 15. LED address mapping

Address	MSB	LSB
0x00	LED/ Seg 2	LED/ Seg 1
0x01	LED/ Seg 4	LED/ Seg 3
0x02	LED/ Seg 6	LED/ Seg 5
0x03	LED/ Seg 8	LED/ Seg 7

Default is constant brightness control with 14/16 pulse width.

During normal operation, the user defined value will be stored in the respective location.

8.3.1 Display setting (maximum number of digits):

The 3-bit values corresponding to selection of number of digits of display are shown below:

- 000: 1 digit 8 segments
- 001: 2 digits 8 segments
- 010: 3 digits 8 segments
- 011: 4 digits 8 segments
- 100: 5 digits 8 segments
- 101: 6 digits 8 segments

Select the number of digits by writing the value in page 0x10 and the address 0x00 in LSB2 to LSB0.

8.3.2 Dimming setting (brightness levels):

The 4-bit values corresponding to different brightness levels are shown below:

- 0000: pulse width is 1/16
- 0001: pulse width is 2/16
- 0010: pulse width is 4/16
- 0011: pulse width is 10/16
- 0100: pulse width is 11/16
- 0101: pulse width is 12/16
- 0110: pulse width is 13/16
- 0111: pulse width is 14/16

Set the dimming timing (write into respective address location from 0x00 to 0x03; page 0x10 & 0x11).

8.4 Display memory

The display memory stores the display data and sends to the LED when the display is on. The address pointer, memory page and write signal indicates to this block the location to write the data. This block will manage the address pointer. When the user writes a first byte, the address increments by one if in auto-increment mode, else the address pointer remains in the same location. The initial address is latched during the write/read command into the address pointer. The display memory (7-segment/LED) is directly mapped into the display segments. The user can access only one bank at a time in both the read and write modes. The memory block is split into 4 pages.

Table 16. Memory page address

Page 1 7 segment memory	Page 2 LED Display	Page 3 7 segment brightness setting	Page 4 LED brightness setting
Addr 0x00 to 0x05 (40 bit)	Addr 0x00 (8 bit)	Addr 0x00 to 0x03 (32bit)	Addr 0x00 to 0x03 (32bit)

7-segment display memory page 0x00:

Table 17. 7-segment display address

Address	Data
0x00	0x00
0x01	0x00
0x02	0x00
0x03	0x00
0x04	0x00
0x05	0x00

LED display memory page 0x01:

Table 18. LED display address

Address	Data
0x00h	0x00h

Initial memory:

Default memory value is "00" in all locations.

During operation:

User defined value in these locations.

When the user wants to read the data from a particular location, the user sends the address page through read command and chooses the mode of the address pointer (fixed or auto). In this case, the user can access the whole memory area in that particular page (maximum 0 x 05).

The display RAM stores the data transmitted from an external device to the STLED316S through the serial interface; addresses are as follows, in 8-bits unit:

Seg1	Seg4	Seg8
00 H _L	00 H _U	DIG2
01 H _L	01 H _U	DIG3
02 H _L	02 H _U	DIG4
03 H _L	03 H _U	DIG5
04 H _L	04 H _U	DIG6
05 H _L	05 H _U	DIG7

b0	b3	b4	b7
XX H _L		XX H _U	

“0” in memory means GND on output; “1” in memory means V_{CC} on output.

9 Key-scanning and display timing

During the first cycle, the 16 channels are used for the keyscan. The keyscan duration is made up of 64 μ s. The second cycle is used for the display of the LED (discrete). The maximum time is 512 μ s and the 3rd-8th cycles are used for the 7-segment display. The number of cycles will increase or decrease depending upon the user configuration.

By default, the configuration is made up of 4 cycles. If any data is written to the discrete LED, only then the 2nd cycle is valid. Otherwise the 7-segment moves from 2nd-7th cycle. This is a continuous operation. During the normal operation, the user cannot control or stop the timing generation.

One cycle of key scanning consists of one frame, and data of 8 x 2 matrices are stored in the RAM.

9.1 Serial communication format (reception)

The figure below shows the “reception” by STLED316S for command/data write sequence. The STB must be low for 1 μ s before the first and last clock rise. The minimum time the STB must remain low is 9 μ s.

The maximum clock frequency is 1 MHz with a duty cycle of 50%. Data set-up and hold time must be 100 ns.

Figure 5. Serial communication format (reception)

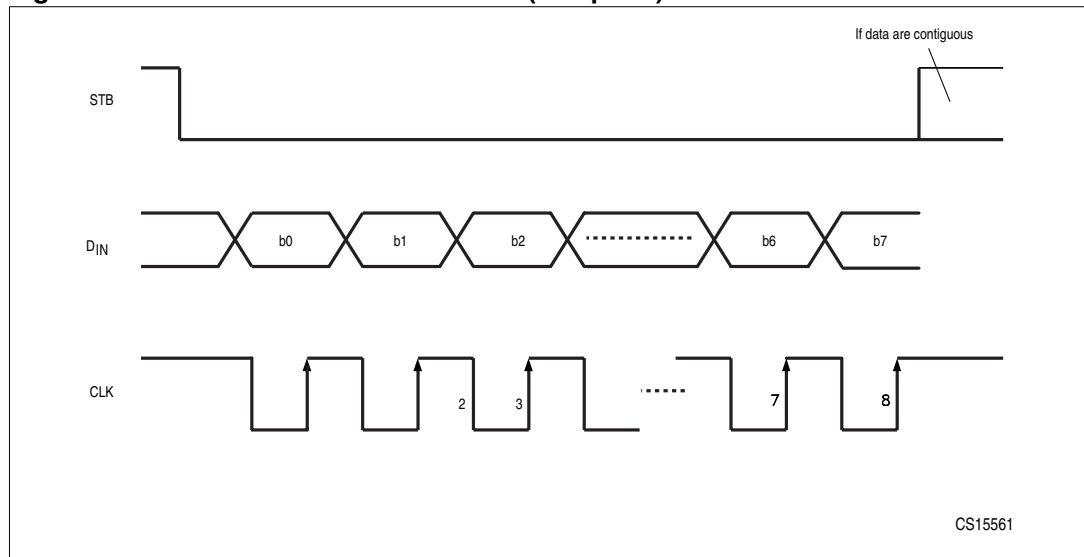

9.2 Serial communication format (transmission)

The figure below shows the “transmission” from STLED316S for data read sequence.

Figure 6. Serial communication format (transmission)

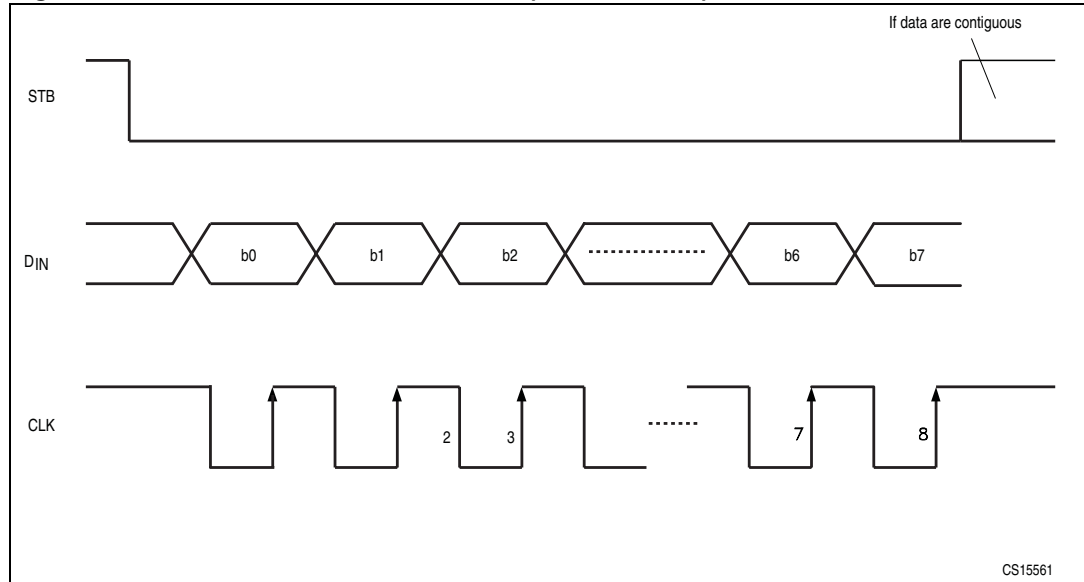

Because the DIN/DOUT pin in a bi-directional pin, it is recommended to connect an external pull-up resistor to this pin (1 KΩ to 10 KΩ).

Note: No minimum wait time is needed to read the data from the device. The STLED316S will output the data about 250 ns after the 8th clock pulse’s falling edge. It is therefore suggested that the host must release the bus within 100ns after clocking the last bit on the 8th clock pulse. The STLED316S is able to clock out the valid data on the immediate falling edge of the CLK without missing any clock cycle.

10 Switching characteristics waveform

Figure 7. Switching characteristics waveform

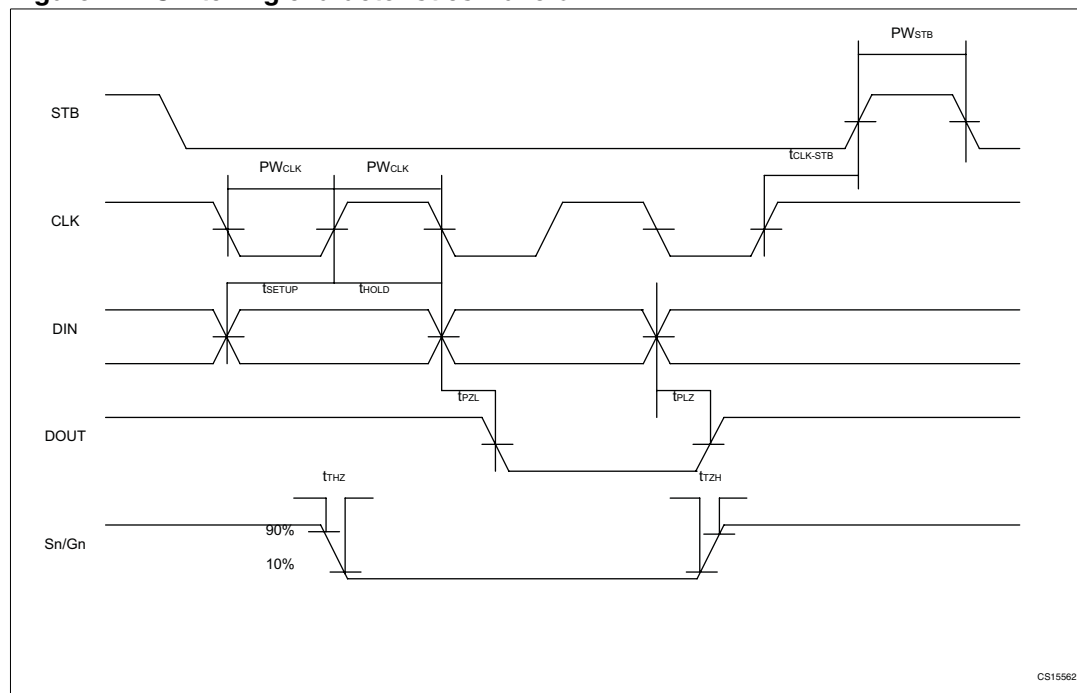

CS15562

11 Application information

11.1 Graph of ISET against RSET

Figure 8. Graph of ISET against RSET

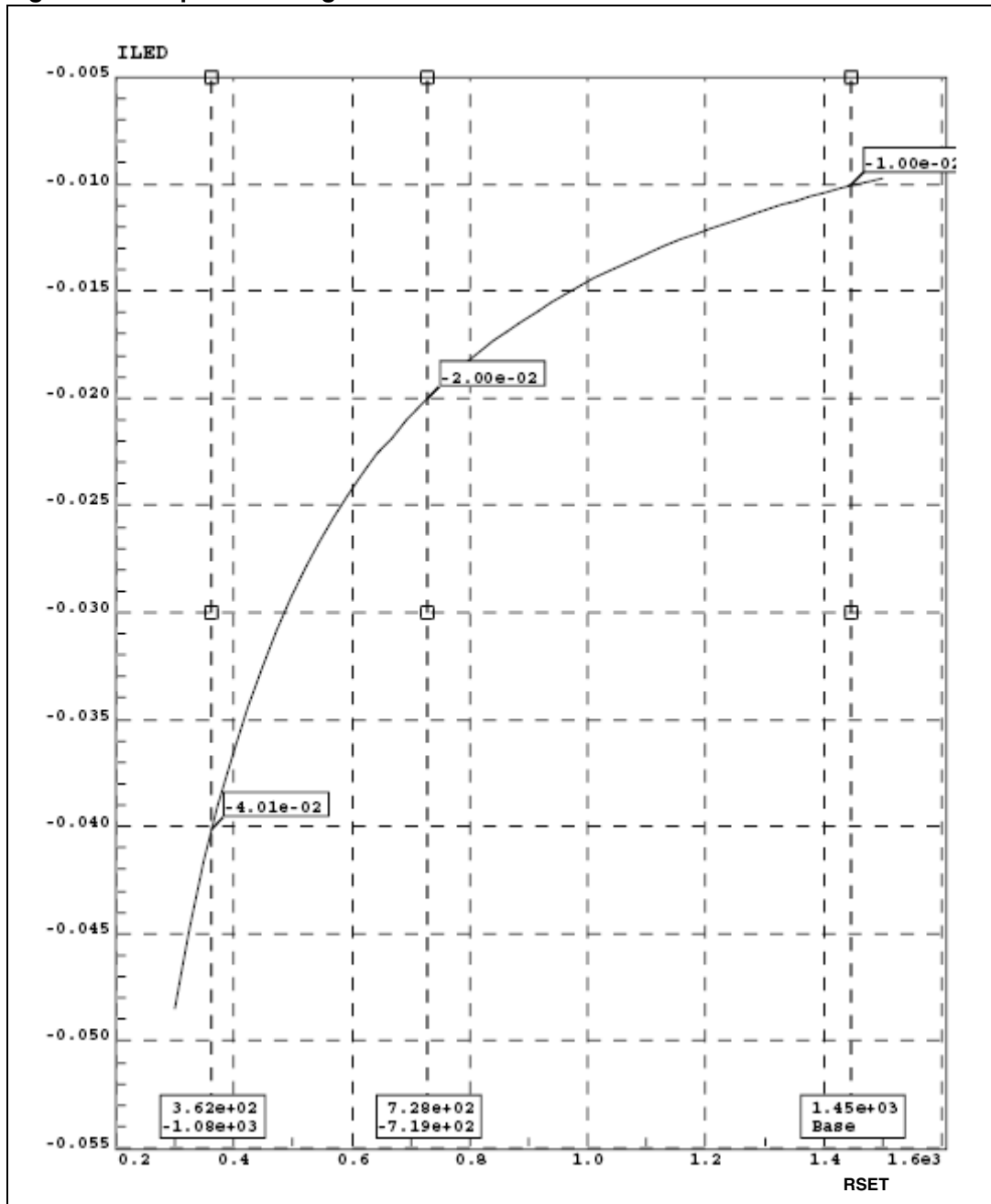

11.2 Power supply sequencing

Proper power-supply sequencing is advised for all CMOS devices. It is recommended to always apply V_{CC} before applying any signals to the input/output or control pins.

11.3 Application diagram

Figure 9. STLED316S application diagram

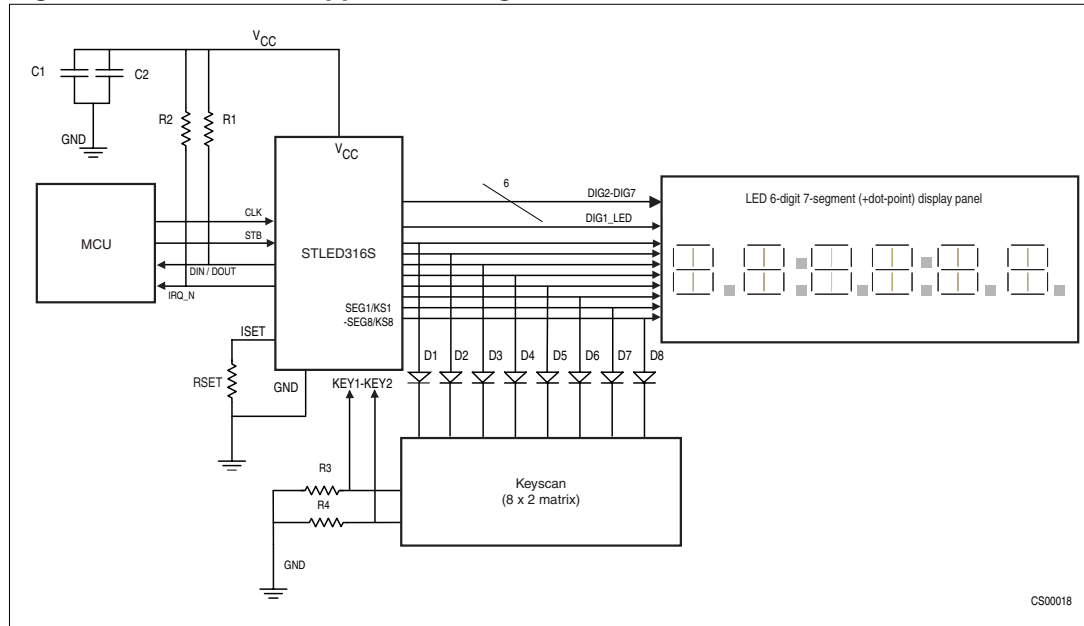

Table 19. Part list

Resistors	Capacitors	Diodes	Supply V
RSET = external resistor for current setting	C1 = 33 μ F (25V) electrolytic	D1-D8 = 1N4148	VCC = 5 V \pm 10%
R1 = 1-10 K Ω DIN/DOUT external pull-up resistor	C2 = 0.01- 0.1 μ F (25 V) ceramic		
R2 = 1-10 K Ω IRQ_N external pull-up resistor			
R3-R4 = 10 K Ω external key-matrix pull-down resistors			

12 Package mechanical data

In order to meet environmental requirements, ST offers these devices in ECOPACK[®] packages. These packages have a Lead-free second level interconnect. The category of second level interconnect is marked on the package and on the inner box label, in compliance with JEDEC Standard JESD97. The maximum ratings related to soldering conditions are also marked on the inner box label. ECOPACK is an ST trademark. ECOPACK specifications are available at: www.st.com.

Figure 10. SO-24 package outline

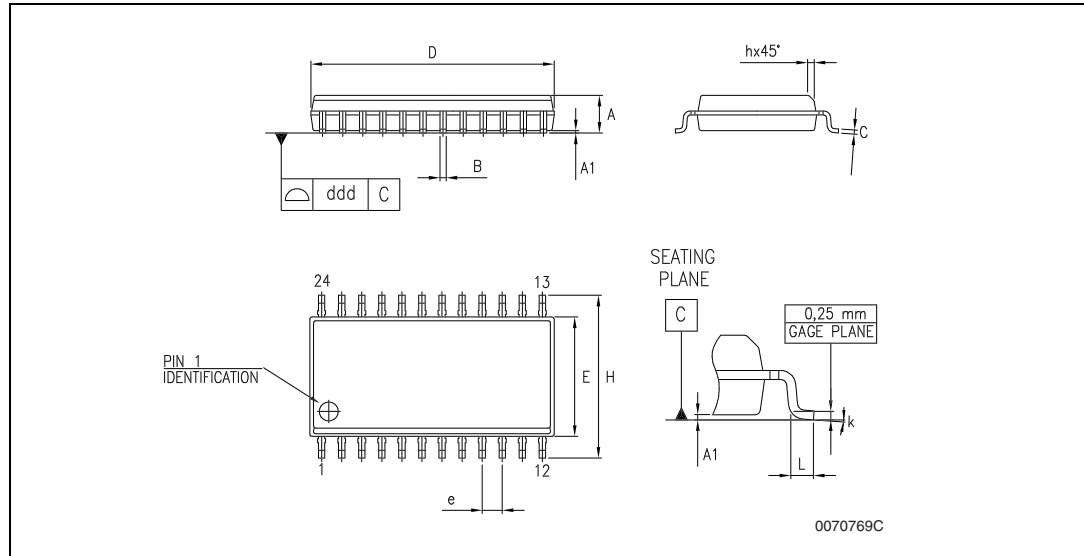

Table 20. SO-24 package mechanical data

Symbol	millimeters			inches		
	Min	Typ	Max	Min	Typ	Max
A	2.35		2.65	0.093		0.104
A1	0.1		0.30	0.004		0.012
B	0.33		0.51	0.013		0.020
C	0.23		0.32	0.009		0.013
D	15.20		15.60	0.598		0.614
E	7.4		7.6	0.291		0.299
e		1.27			0.050	
H	10.00		10.65	0.394		0.419
h	0.25		0.75	0.010		0.030
L	0.4		1.27	0.016		0.050
k	0°		8°	0°		8°
ddd			0.100			0.004

13 Revision history

Table 21. Document revision history

Date	Revision	Changes
9-Jan-2008	1	Initial release.

Please Read Carefully:

Information in this document is provided solely in connection with ST products. STMicroelectronics NV and its subsidiaries ("ST") reserve the right to make changes, corrections, modifications or improvements, to this document, and the products and services described herein at any time, without notice.

All ST products are sold pursuant to ST's terms and conditions of sale.

Purchasers are solely responsible for the choice, selection and use of the ST products and services described herein, and ST assumes no liability whatsoever relating to the choice, selection or use of the ST products and services described herein.

No license, express or implied, by estoppel or otherwise, to any intellectual property rights is granted under this document. If any part of this document refers to any third party products or services it shall not be deemed a license grant by ST for the use of such third party products or services, or any intellectual property contained therein or considered as a warranty covering the use in any manner whatsoever of such third party products or services or any intellectual property contained therein.

UNLESS OTHERWISE SET FORTH IN ST'S TERMS AND CONDITIONS OF SALE ST DISCLAIMS ANY EXPRESS OR IMPLIED WARRANTY WITH RESPECT TO THE USE AND/OR SALE OF ST PRODUCTS INCLUDING WITHOUT LIMITATION IMPLIED WARRANTIES OF MERCHANTABILITY, FITNESS FOR A PARTICULAR PURPOSE (AND THEIR EQUIVALENTS UNDER THE LAWS OF ANY JURISDICTION), OR INFRINGEMENT OF ANY PATENT, COPYRIGHT OR OTHER INTELLECTUAL PROPERTY RIGHT.

UNLESS EXPRESSLY APPROVED IN WRITING BY AN AUTHORIZED ST REPRESENTATIVE, ST PRODUCTS ARE NOT RECOMMENDED, AUTHORIZED OR WARRANTED FOR USE IN MILITARY, AIR CRAFT, SPACE, LIFE SAVING, OR LIFE SUSTAINING APPLICATIONS, NOR IN PRODUCTS OR SYSTEMS WHERE FAILURE OR MALFUNCTION MAY RESULT IN PERSONAL INJURY, DEATH, OR SEVERE PROPERTY OR ENVIRONMENTAL DAMAGE. ST PRODUCTS WHICH ARE NOT SPECIFIED AS "AUTOMOTIVE GRADE" MAY ONLY BE USED IN AUTOMOTIVE APPLICATIONS AT USER'S OWN RISK.

Resale of ST products with provisions different from the statements and/or technical features set forth in this document shall immediately void any warranty granted by ST for the ST product or service described herein and shall not create or extend in any manner whatsoever, any liability of ST.

ST and the ST logo are trademarks or registered trademarks of ST in various countries.

Information in this document supersedes and replaces all information previously supplied.

The ST logo is a registered trademark of STMicroelectronics. All other names are the property of their respective owners.

© 2008 STMicroelectronics - All rights reserved

STMicroelectronics group of companies

Australia - Belgium - Brazil - Canada - China - Czech Republic - Finland - France - Germany - Hong Kong - India - Israel - Italy - Japan - Malaysia - Malta - Morocco - Singapore - Spain - Sweden - Switzerland - United Kingdom - United States of America

www.st.com

Компания «Океан Электроники» предлагает заключение долгосрочных отношений при поставках импортных электронных компонентов на взаимовыгодных условиях!

Наши преимущества:

- Поставка оригинальных импортных электронных компонентов напрямую с производств Америки, Европы и Азии, а так же с крупнейших складов мира;
- Широкая линейка поставок активных и пассивных импортных электронных компонентов (более 30 млн. наименований);
- Поставка сложных, дефицитных, либо снятых с производства позиций;
- Оперативные сроки поставки под заказ (от 5 рабочих дней);
- Экспресс доставка в любую точку России;
- Помощь Конструкторского Отдела и консультации квалифицированных инженеров;
- Техническая поддержка проекта, помощь в подборе аналогов, поставка прототипов;
- Поставка электронных компонентов под контролем ВП;
- Система менеджмента качества сертифицирована по Международному стандарту ISO 9001;
- При необходимости вся продукция военного и аэрокосмического назначения проходит испытания и сертификацию в лаборатории (по согласованию с заказчиком);
- Поставка специализированных компонентов военного и аэрокосмического уровня качества (Xilinx, Altera, Analog Devices, Intersil, Interpoint, Microsemi, Actel, Aeroflex, Peregrine, VPT, Syfer, Eurofarad, Texas Instruments, MS Kennedy, Miteq, Cobham, E2V, MA-COM, Hittite, Mini-Circuits, General Dynamics и др.);

Компания «Океан Электроники» является официальным дистрибьютором и эксклюзивным представителем в России одного из крупнейших производителей разъемов военного и аэрокосмического назначения «JONHON», а так же официальным дистрибьютором и эксклюзивным представителем в России производителя высокотехнологичных и надежных решений для передачи СВЧ сигналов «FORSTAR».



JONHON

«JONHON» (основан в 1970 г.)

Разъемы специального, военного и аэрокосмического назначения:

(Применяются в военной, авиационной, аэрокосмической, морской, железнодорожной, горно- и нефтедобывающей отраслях промышленности)

«FORSTAR» (основан в 1998 г.)

ВЧ соединители, коаксиальные кабели, кабельные сборки и микроволновые компоненты:

(Применяются в телекоммуникациях гражданского и специального назначения, в средствах связи, РЛС, а так же военной, авиационной и аэрокосмической отраслях промышленности).



Телефон: 8 (812) 309-75-97 (многоканальный)

Факс: 8 (812) 320-03-32

Электронная почта: ocean@oceanchips.ru

Web: <http://oceanchips.ru/>

Адрес: 198099, г. Санкт-Петербург, ул. Калинина, д. 2, корп. 4, лит. А