

HIGH-SIDE CURRENT SENSE AMPLIFIER

Features

- Complete, unidirectional high-side current sense capability
- 0.2% full-scale accuracy
- +5 to +36 V supply operation
- 85 dB power supply rejection
- 90 μ A max supply current
- 9 μ A shutdown current
- Operating Temperature Range: -40 to +85 $^{\circ}$ C
- 5-pin SOT-23 package
- RoHS-compliant

Applications

- Battery chargers
- Smart battery packs
- DC motor control
- Backup systems
- Current control applications

Description

The Si8540 is a unidirectional, 36 V (max), high-side current sense amplifier for use in applications requiring current monitoring and/or control. This device draws bias current from the high-side line to which it is attached, eliminating the need for an external supply. It measures current from 0.1 to 10 A by sensing the voltage across an external sense resistor (or PCB trace) from dc to 20 kHz and can achieve measurement accuracies of 0.2% (typical) at full load. The device output is a current signal proportional to measured current and is easily converted to a scaled voltage using a single external resistor. The Si8540 is available in compact SOT-23 package.

Functional Block Diagram

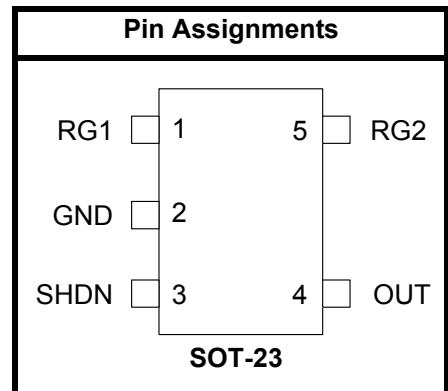
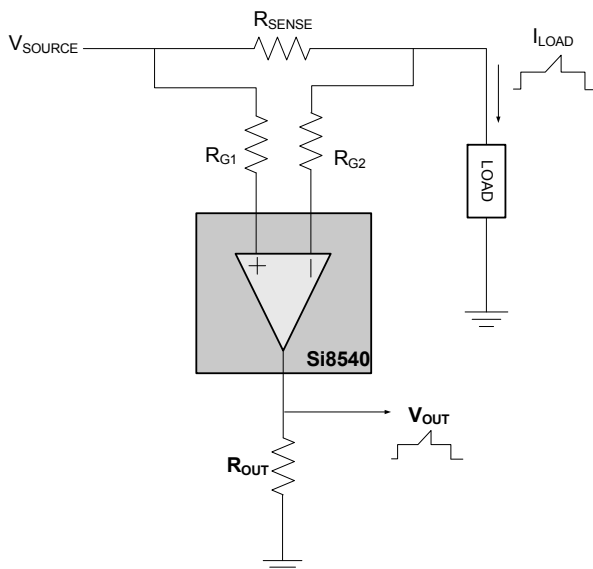

Patents pending

TABLE OF CONTENTS

| <u>Section</u> | <u>Page</u> |
|-----------------------------------------------|--------------------|
| 1. Electrical Specifications | 4 |
| 2. Typical Application Schematic | 6 |
| 3. Functional Description | 7 |
| 3.1. Application Information | 7 |
| 4. Typical Performance Data | 9 |
| 5. Pin Descriptions | 11 |
| 6. Ordering Guide | 12 |
| 6.1. Device Marking | 13 |
| 7. Package Outline: SOT-23 | 14 |
| 8. Land Pattern: SOT-23 | 15 |
| Document Change List | 16 |
| Contact Information | 18 |

1. Electrical Specifications

Table 1. Absolute Maximum Ratings

| Parameter | Value | Unit |
|-------------------------------------------------------------------------------------------------------------------------------------------------------------------------------------------------------------------------------------------------------------------------------------------------------------------------------------------------------------------------------------------------------------|-------------|------|
| Voltage at RG1, RG2, SHDN to GND | -0.3 to +40 | V |
| Differential Input Voltage, RG1 to RG2 | ±0.3 | V |
| Voltage at OUT | -0.3 to +8 | V |
| Current into SHDN, GND, OUT, RG1, RG2 | ±50 | mA |
| Continuous Power Dissipation ($T_A = +70\text{ °C}$) 5-pin SOT23 derate 7.1 mW/°C above +70 °C* | 571 | mW |
| Operating Temperature Range | -40 to +85 | °C |
| Junction Temperature, T_{JMAX} | Up to +150 | °C |
| *Note: The device is mounted on a standard PCB with a 100 mm ² copper foil connected to the GND pin, no airflow. Permanent device damage may occur if the absolute maximum ratings are exceeded, and prolonged use at the absolute maximum ratings may affect reliability. It is recommended that the device operate within the limits indicated in Table 2, "DC and AC Characteristics". | | |

Table 2. DC and AC Characteristics(Unless otherwise specified: $V_{RG1} = +5$ to $+36$ V, $RG1 = RG2 = 200$, $V_{SENSE} = 0$ V, $T_A = -40$ to $+85$ °C)

| Parameter | Symbol | Test Condition | Min | Typ | Max | Unit |
|----------------------------------------|-----------------------|---------------------------------------------------------------------------------------------------------|--------|------------|------------------------------|--------------------|
| Operating Voltage | V_{RG1} | | 5 | — | 36 | V |
| Operating Frequency | F | | 0 | 20 | — | kHz |
| Total Input Current | $I_{RG1} + I_{RG2}$ | $I_{LOAD} = 0$ A | — | 46 | 90 | μ A |
| Input Currents | I_{RG1} , I_{RG2} | $I_{LOAD} = 0$ A | — | 23 | 45 | μ A |
| Input Current Matching | I_{OS} | $I_{RG1} - I_{RG2}$ | — | ± 0.4 | ± 1.5 | μ A |
| Sense Voltage ¹ | V_{SENSE} | | — | 100 | — | mV |
| OUT Current Accuracy | I_{RG}/I_{OUT} | $V_{SENSE} = 100$ mV | — | ± 0.2 | ± 1.5 | % |
| No-Load OUT Error | | $V_{RG1} = 10$ V, $V_{SENSE} = 0$ V | — | 0.5 | 15 | μ A |
| Low-Level OUT Error | | $V_{RG1} = 10$ V, $V_{SENSE} = 3$ mV | — | ± 0.5 | ± 10 | μ A |
| Power-Supply Rejection | PSR | $V_{SENSE} = 100$ mV | — | -85 | — | dB |
| Shutdown Supply Current | $I_{RG1} + I_{RG2}$ | $V_{SHDN} = 2.4$ V | — | 3.5 | 9 | μ A |
| SHDN Input Low Voltage | V_{IL} | | — | — | 0.3 | V |
| SHDN Input Low Current | I_{IL} | $V_{SHDN} = 0$ V | — | — | 1.0 | μ A |
| SHDN Input High Voltage | V_{IH} | | 2.4 | — | — | V |
| SHDN Input High Current | I_{IH} | $V_{SHDN} = 2.4$ V | — | — | 1.0 | μ A |
| OUT Output Voltage Range | V_{OUT} | V_{OUT} clamped at 8 V | 0 | — | $V_{RG1} - 3.5$ (< 8) | V |
| OUT Output Resistance (Internal) | | $I_{OUT} = 1.5$ mA | 1 | 3 | — | M Ω |
| OUT Rise, Fall Time | | $V_{SENSE} = 5$ mV to 150 mV, $R_{OUT} = 2 = k\Omega$, $C_{OUT} = 50$ pF, 10% to 90% (Note 2) | — — | 0.4 0.5 | — — | μ s μ s |
| OUT Settling Time to 1% of Final Value | | $V_{SENSE} = 5$ to 150 mV, $R_{OUT} = 2 k\Omega$, $C_{OUT} = 50$ pF (Note 2) | — — | 1 2 | — — | μ s μ s |
| Maximum Output Current | I_{OUT} | For $I_{OUT} > 1.5$ mA the internal current limitation starts to limit the output current | 1.5 | — | 10 | mA |

Notes:

- V_{SENSE} is the voltage across the sense resistor.
- C_{OUT} is the load capacitance seen by the OUT pin.

2. Typical Application Schematic

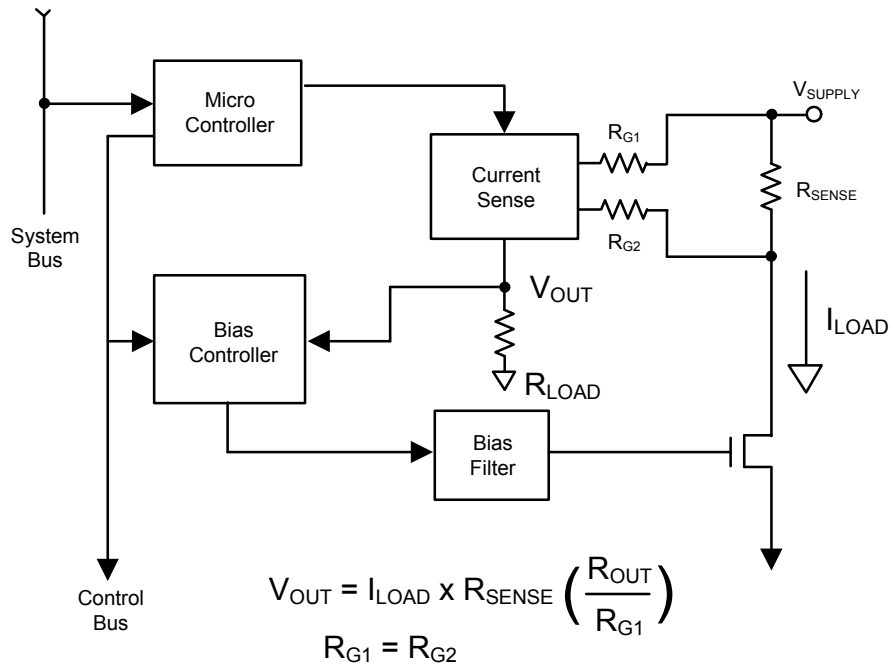

Figure 1. Connecting the Si8540 in a Power Control Application

3. Functional Description

The Si8540 is designed to operate over an input common-mode range of 5 to 36 V. Figure 2 shows an example Si8540 application with external sense resistor, R_{SENSE} , external current gain-setting resistors, R_{G1} and R_{G2} , and output scaling resistor, R_{OUT} . The supply current flowing into the Si8540 inverting and non-inverting inputs (R_{G1} , R_{G2}) is negligible compared to I_{LOAD} and, as a result, has no appreciable effect on measurement accuracy. The internal current sense amplifier measures the differential input voltage, V_{SENSE} , and generates an output current proportional to I_{LOAD} . Resistor R_{OUT} converts this current to a voltage, and its value determines the output signal gain. The Si8540 is placed in a low-power shutdown mode when SHDN is at V_{IH} .

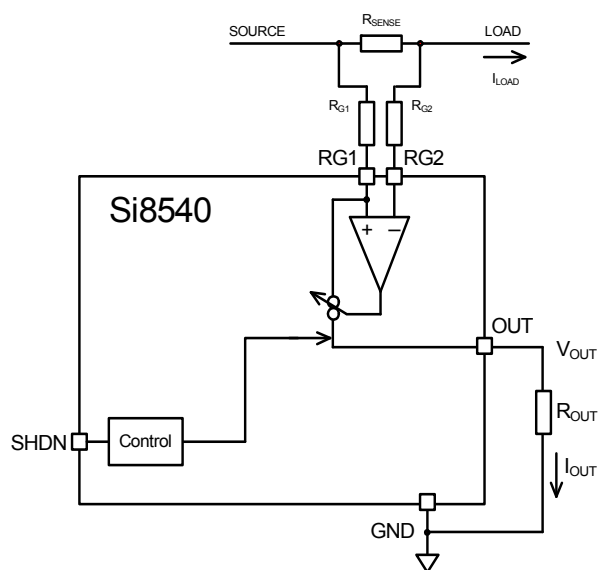

Figure 2. Si8540 Application Circuit

3.1. Application Information

The Si8540 can sense a wide range of currents with different sense resistor values. Table 3 lists typical operational values.

Table 3. Recommended Current Sense Resistor for a Given Full-Scale Load Current

| Full-scale Load Current I_{SENSE} (A) | Current-Sense Resistor R_{SENSE} (m Ω) | Gain-Setting Resistors, $R_{G1} = R_{G2}$ (Ω) | Output Resistor, R_{OUT} (k Ω) | Full-Scale Output Voltage, V_{OUT} (V) | Scale Factor V_{OUT}/I_{SENSE} (V/A) | Typical Error at 1, 10 and 100% of Full Load (%) | | |
|-----------------------------------------|--------------------------------------------------|--------------------------------------------------------|------------------------------------------|------------------------------------------|----------------------------------------|--------------------------------------------------|-----|------|
| | | | | | | 1% | 10% | 100% |
| 0.1 | 1000 | 200 | 5 | 2.5 | 25 | 10 | 1 | 0.2 |
| 1 | 100 | 200 | 5 | 2.5 | 2.5 | 10 | 1 | 0.2 |
| 5 | 20 | 100 | 2 | 2 | 0.4 | 5 | 1 | 0.2 |
| 10 | 5 | 50 | 2 | 2 | 0.2 | 5 | 1 | 0.4 |

3.1.1. Selecting R_{SENSE}

Selecting R_{SENSE} involves making the best trade-off between power efficiency and accuracy. Low R_{SENSE} values dissipate less power while higher values maximize accuracy. In general, it is best to choose a relatively high value for R_{SENSE} in applications where the measured current is small. For higher current applications, the sense resistor should be able to dissipate the heat from its power loss; otherwise, its value may drift or it may fail open, possibly causing a large differential voltage across R_{G1} and R_{G2} that may damage the device. In most applications, R_{SENSE} should have low inductance to reduce the impact of any high-frequency components in the current being measured (low inductance metal film resistors are recommended). Also, note that the Si8540 requires at least 3.5 V of voltage headroom between the voltage at pin R_{G1} and pin OUT . This voltage headroom decreases as R_{SENSE} increases. A good guideline for determining the maximum value for R_{SENSE} is shown in the following equation:

$$R_{SENSEmax} = (V_{SOURCE} - V_{OUTmax} - 3.5 \text{ V}) / I_{LOAD}$$

Where:

V_{SOURCE} is the high-side voltage

V_{OUTmax} is the full-scale output voltage at the OUT pin

I_{LOAD} is the current passing through R_{SENSE} measured by the Si8540

3.1.2. Selecting R_{G1} and R_{G2}

The values of resistors R_{G1} and R_{G2} determine the sense amp current-gain. These two resistors must have the same value, and resulting current gain is equal to R_{SENSE} / R_G (where $R_G = R_{G1} = R_{G2}$).

The minimum value of R_G is determined by the maximum current at the OUT pin (1.5 mA) and by the resistance between the internal current sense amp input and the sense resistor (approximately 0.2 Ω). As the value of R_G is reduced, the input resistance becomes a larger portion of the total gain-setting resistance. This gain error can be compensated by trimming R_G or R_{OUT} . A good guideline for determining the maximum value for R_G is shown in the following equation:

$$R_{Gmax} = (V_{SENSEmax} / 1.5 \text{ mA})$$

Where:

R_{Gmax} is the largest value for R_{G1} and R_{G2}

$V_{SENSEmax}$ is the value of V_{SENSE} at maximum I_{LOAD}

Note that for a given value of V_{SENSE} , a decrease of the R_G resistor values causes a corresponding increase in current at the OUT pin. This causes additional power to be dissipated in R_{OUT} rather than in the load, which can reduce efficiency. Note also that mismatches in the currents passing R_{G1} and R_{G2} (IOS) together with R_G affect the full scale error.

This error can be reduced by lowering the values of R_{G1} , R_{G2} and/or lowering their tolerances. This error can also be reduced by increasing the value of R_{SENSE} .

3.1.3. Choosing R_{OUT}

R_{OUT} must be chosen to generate the required full-scale output voltage at the full scale I_{OUT} , which, in turn, is determined by R_{G1} , R_{G2} , and R_{SENSE} . The upper limit of R_{OUT} is determined by the input impedance of the device that it drives. This input impedance should be much larger than R_{OUT} ; otherwise, measurement accuracy will be degraded. A good guideline for choosing the value of R_{OUT} is shown in the following equation:

$$(V_{OUTfullscale} \times R_G) / (I_{LOAD} \times R_{SENSE})$$

4. Typical Performance Data

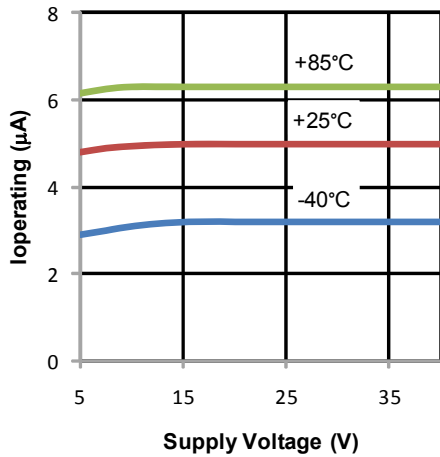

Figure 3. Supply Current vs. Supply Voltage

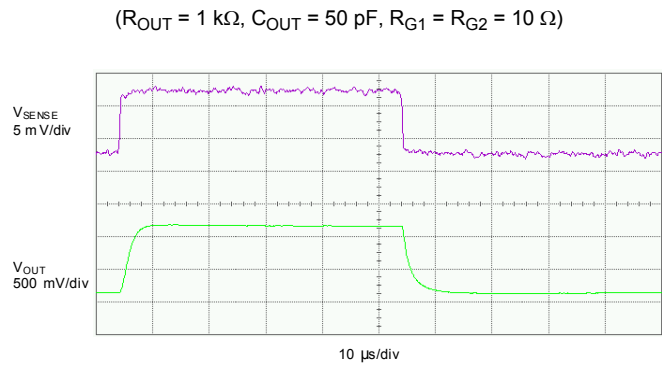

Figure 6. Transient Response 2

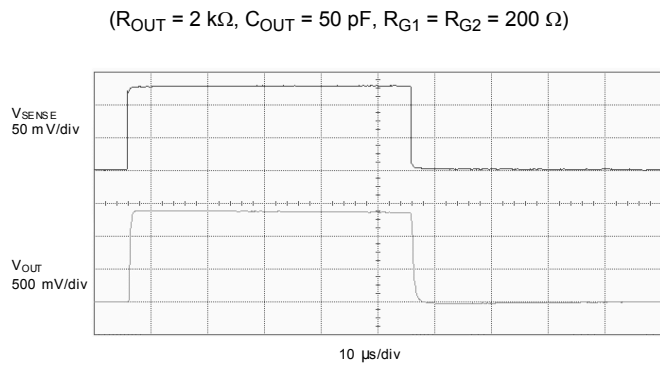

Figure 4. Transient Response 1

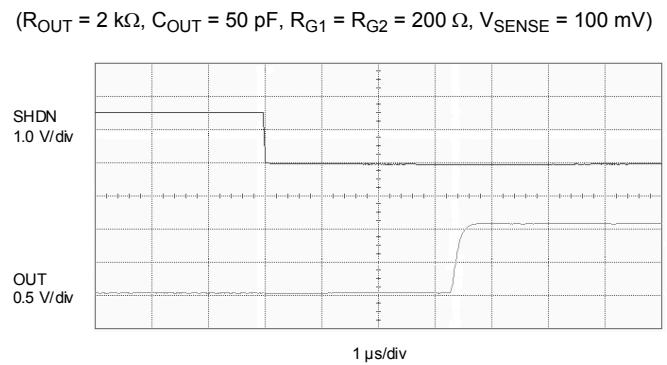

Figure 7. Startup Delay

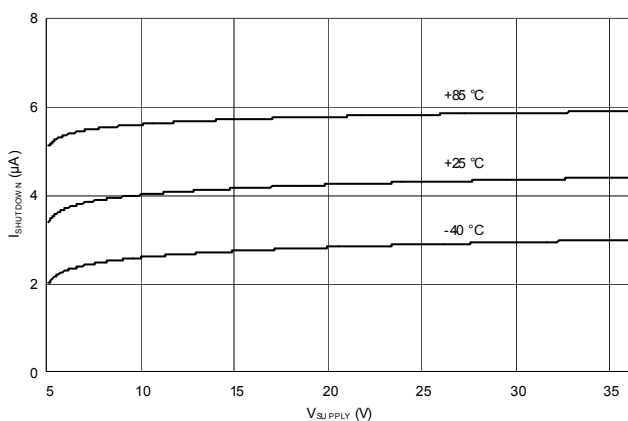

Figure 5. Shutdown Supply Current vs. Supply Voltage

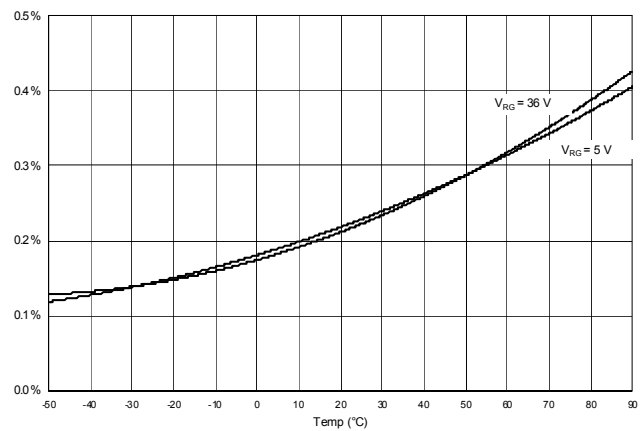

Figure 8. Output Error vs. Temperature

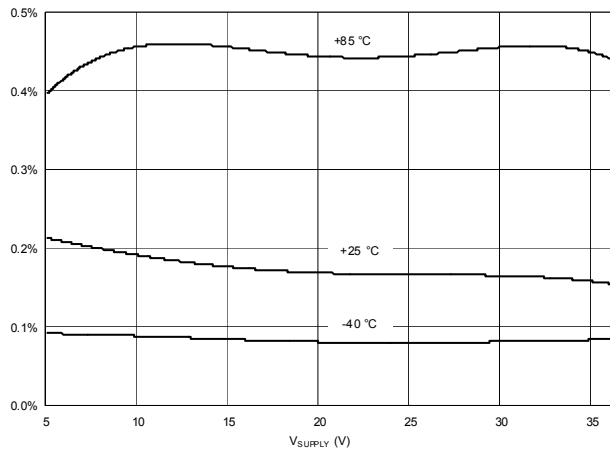

Figure 9. Output Error vs. Supply Voltage

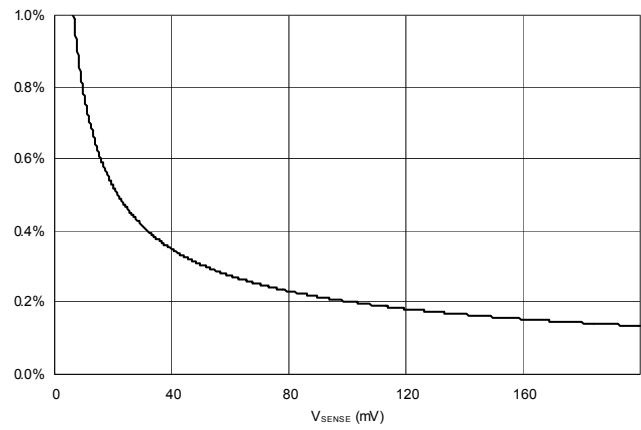

Figure 10. Output Error vs. Sense Voltage

5. Pin Descriptions

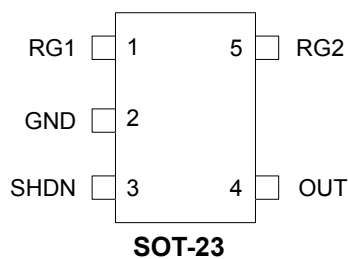

Figure 11. Pin Configuration

Table 4. Pin Descriptions

| Pin Number | Name | Description |
|--------------|------|-------------------------------------------------------------------------|
| SOT23 | | |
| 1 | RG1 | Power-side input. |
| 2 | GND | Ground. |
| 3 | SHDN | Shutdown input. Ground for normal operation. High voltage for shutdown. |
| 4 | OUT | Current output. |
| 5 | RG2 | Load-side input. |

Si8540

6. Ordering Guide

| Ordering Part # ¹ | Temperature Range | Package |
|------------------------------|-------------------|---------------------|
| Si8540-B-FW | -40 to +85 °C | SOT-23 ² |

Notes:

1. Tape and reel options are specified by adding an "R" suffix to the ordering part number.
Example: "Si8450-B-FWR" indicates the SOT-23 package option in a tape and reel carrier.
2. Moisture sensitivity level (MSL) is (MSL2A) for SOT-23 package with peak reflow temperature of (260 °C) according to JEDEC industry-standard classifications.

6.1. Device Marking

6.1.1. SOT-23 Package Top Mark

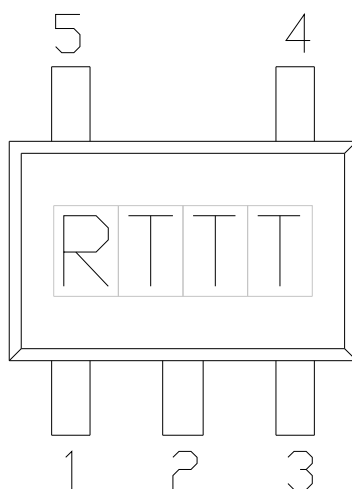

6.1.2. Top Marking Explanation

| | | |
|------------------------|--------------------------|------------------------------------------------------|
| Line 1 Marking: | Manufacturing trace code | R = Device revision (B) TTT = Assembly trace code |
|------------------------|--------------------------|------------------------------------------------------|

7. Package Outline: SOT-23

Figure 12 illustrates the package details for the SOT-23. Table 5 lists the values for the dimensions shown in the illustration.

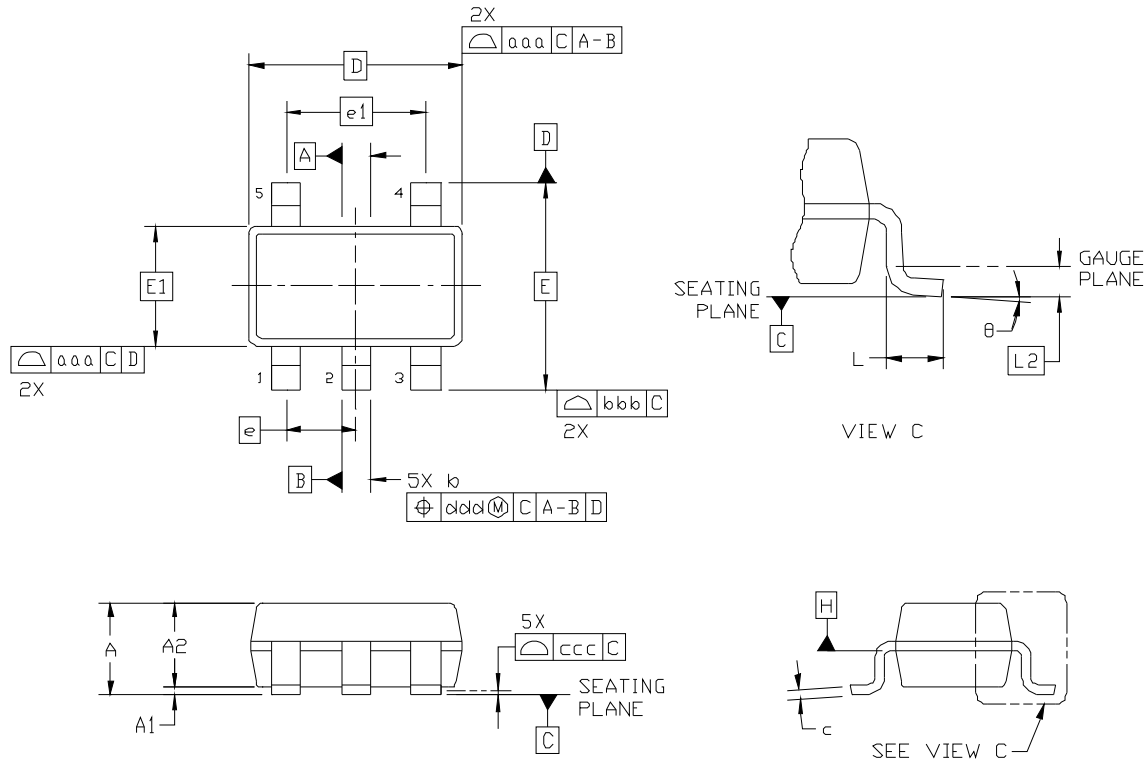

Figure 12. SOT-23 Package

Table 5. SOT-23 Package Diagram Dimensions

| Dimension | Min | Max | Dimension | Min | Max |
|-----------|----------|------|-----------|----------|------|
| A | — | 1.45 | E1 | 1.90 BSC | |
| A1 | 0.00 | 0.15 | L | 0.30 | 0.60 |
| A2 | 0.90 | 1.30 | L2 | 0.25 BSC | |
| b | 0.30 | 0.50 | θ | 0° | 8° |
| c | 0.08 | 0.20 | aaa | 0.15 | |
| D | 2.90 BSC | | bbb | 0.20 | |
| E | 2.80 BSC | | ccc | 0.10 | |
| E1 | 1.60 BSC | | ddd | 0.20 | |
| e | 0.95 BSC | | | | |

Notes:

1. All dimensions shown are in millimeters (mm) unless otherwise noted.
2. Dimensioning and Tolerancing per ANSI Y14.5M-1994.
3. This drawing conforms to the JEDEC Solid State Outline MO-178, Variation AA.
4. Recommended card reflow profile is per the JEDEC/IPC J-STD-020D specification for Small Body Components.

8. Land Pattern: SOT-23

Figure 13 illustrates the recommended land pattern details for the SOT-23 device. Table 6 lists the values for the dimensions shown in the illustration.

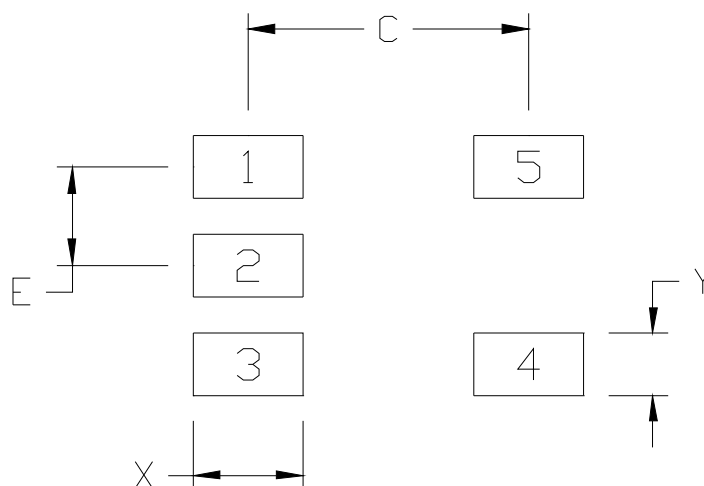

Figure 13. SOT-23 Land Pattern

Table 6. SOT-23 Land Pattern Dimensions

| Dimension | (mm) |
|-----------|------|
| C | 2.70 |
| E | 0.95 |
| X | 1.05 |
| Y | 0.60 |

Notes:

General

1. All dimensions shown are in millimeters (mm) unless otherwise noted.
2. Dimensioning and Tolerancing is per the ANSI Y14.5M-1994 specification.
3. This Land Pattern Design is based on the IPC-7351 guidelines.
4. All dimensions shown are at Maximum Material Condition (MMC). Least Material Condition (LMC) is calculated based on a Fabrication Allowance of 0.05 mm.

Card Assembly

5. A No-Clean, Type-3 solder paste is recommended.
6. The recommended card reflow profile is per the JEDEC/IPC J-STD-020D specification for Small Body Components.

DOCUMENT CHANGE LIST

Revision 2.5 (July 2007 Integration Associates) to Revision 1.0 (March 2010 Silicon Laboratories)

- Reformatted document from IA2410 and renamed Si8540.
- Updated " Functional Block Diagram" on page 1.
- Updated " Description" on page 1.
- Updated Table 2 on page 5.
 - OUT current accuracy changed from ± 1 to $\pm 1.5\%$. (max)
 - No-Load OUT Error changed from 5 to 15 μA (max)
 - Low-Level OUT Error changed from ± 5 to ± 10 μA (max)
 - Temperature output error test conditions note updated to include temperature range of -40 to TBD° C.
- Updated "3. Functional Description" on page 7.
- Updated "3.1.1. Selecting R_{SENSE} " on page 8.
- Updated "3.1.2. Selecting RG1 and RG2" on page 8.
- Updated "3.1.3. Choosing R_{OUT} " on page 8.
- Removed temperature sensing function throughout.
- Added recommended PCB Land Pattern sections.
- Reformatted document from "IA2410 Rev 2.5" (Integration Associates) and renamed and re-released as "Si8540 Rev 1.0" (which obsoletes the previous preliminary internal revision 2.6).

Revision 1.0 to Revision 1.1

- MSL for the SOT-23 package improved to MSL2A (see "6. Ordering Guide" on page 12).
- Added "6.1. Device Marking" on page 13.

Revision 1.1 to Revision 1.2

- Removed SOIC-8 package throughout document.

NOTES:

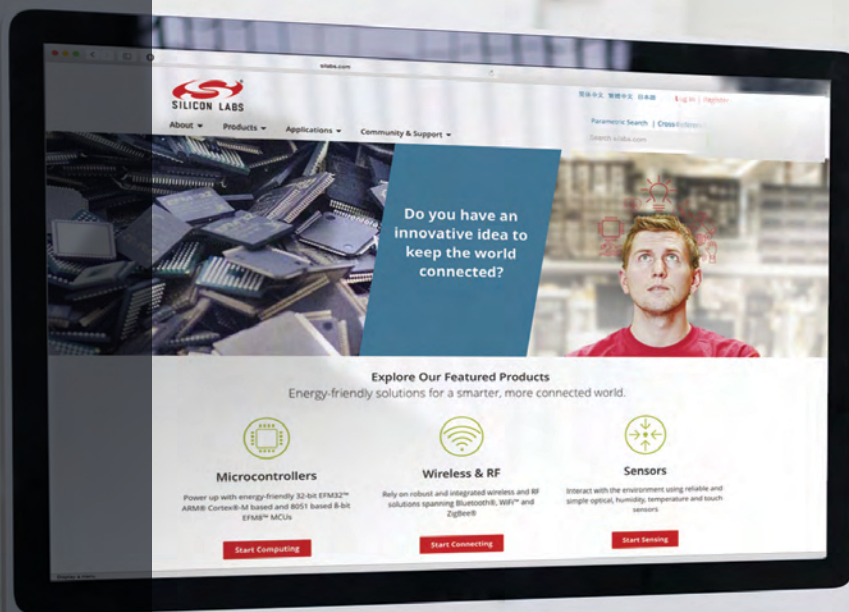

Smart.
Connected.
Energy-Friendly



Products
www.silabs.com/products



Quality
www.silabs.com/quality



Support and Community
community.silabs.com

Disclaimer

Silicon Laboratories intends to provide customers with the latest, accurate, and in-depth documentation of all peripherals and modules available for system and software implementers using or intending to use the Silicon Laboratories products. Characterization data, available modules and peripherals, memory sizes and memory addresses refer to each specific device, and "Typical" parameters provided can and do vary in different applications. Application examples described herein are for illustrative purposes only. Silicon Laboratories reserves the right to make changes without further notice and limitation to product information, specifications, and descriptions herein, and does not give warranties as to the accuracy or completeness of the included information. Silicon Laboratories shall have no liability for the consequences of use of the information supplied herein. This document does not imply or express copyright licenses granted hereunder to design or fabricate any integrated circuits. The products must not be used within any Life Support System without the specific written consent of Silicon Laboratories. A "Life Support System" is any product or system intended to support or sustain life and/or health, which, if it fails, can be reasonably expected to result in significant personal injury or death. Silicon Laboratories products are generally not intended for military applications. Silicon Laboratories products shall under no circumstances be used in weapons of mass destruction including (but not limited to) nuclear, biological or chemical weapons, or missiles capable of delivering such weapons.

Trademark Information

Silicon Laboratories Inc., Silicon Laboratories, Silicon Labs, SiLabs and the Silicon Labs logo, CMEMS®, EFM, EFM32, EFR, Energy Micro, Energy Micro logo and combinations thereof, "the world's most energy friendly microcontrollers", Ember®, EZLink®, EZMac®, EZRadio®, EZRadioPRO®, DSPLL®, ISOmodem®, Precision32®, ProSLIC®, SiPHY®, USBXpress® and others are trademarks or registered trademarks of Silicon Laboratories Inc. ARM, CORTEX, Cortex-M3 and THUMB are trademarks or registered trademarks of ARM Holdings. Keil is a registered trademark of ARM Limited. All other products or brand names mentioned herein are trademarks of their respective holders.



Silicon Laboratories Inc.
400 West Cesar Chavez
Austin, TX 78701
USA

<http://www.silabs.com>

Компания «Океан Электроники» предлагает заключение долгосрочных отношений при поставках импортных электронных компонентов на взаимовыгодных условиях!

Наши преимущества:

- Поставка оригинальных импортных электронных компонентов напрямую с производств Америки, Европы и Азии, а так же с крупнейших складов мира;
- Широкая линейка поставок активных и пассивных импортных электронных компонентов (более 30 млн. наименований);
- Поставка сложных, дефицитных, либо снятых с производства позиций;
- Оперативные сроки поставки под заказ (от 5 рабочих дней);
- Экспресс доставка в любую точку России;
- Помощь Конструкторского Отдела и консультации квалифицированных инженеров;
- Техническая поддержка проекта, помощь в подборе аналогов, поставка прототипов;
- Поставка электронных компонентов под контролем ВП;
- Система менеджмента качества сертифицирована по Международному стандарту ISO 9001;
- При необходимости вся продукция военного и аэрокосмического назначения проходит испытания и сертификацию в лаборатории (по согласованию с заказчиком);
- Поставка специализированных компонентов военного и аэрокосмического уровня качества (Xilinx, Altera, Analog Devices, Intersil, Interpoint, Microsemi, Actel, Aeroflex, Peregrine, VPT, Syfer, Eurofarad, Texas Instruments, MS Kennedy, Miteq, Cobham, E2V, MA-COM, Hittite, Mini-Circuits, General Dynamics и др.);

Компания «Океан Электроники» является официальным дистрибьютором и эксклюзивным представителем в России одного из крупнейших производителей разъемов военного и аэрокосмического назначения «JONHON», а так же официальным дистрибьютором и эксклюзивным представителем в России производителя высокотехнологичных и надежных решений для передачи СВЧ сигналов «FORSTAR».



JONHON

«JONHON» (основан в 1970 г.)

Разъемы специального, военного и аэрокосмического назначения:

(Применяются в военной, авиационной, аэрокосмической, морской, железнодорожной, горно- и нефтедобывающей отраслях промышленности)

«FORSTAR» (основан в 1998 г.)

ВЧ соединители, коаксиальные кабели, кабельные сборки и микроволновые компоненты:

(Применяются в телекоммуникациях гражданского и специального назначения, в средствах связи, РЛС, а так же военной, авиационной и аэрокосмической отраслях промышленности).



Телефон: 8 (812) 309-75-97 (многоканальный)

Факс: 8 (812) 320-03-32

Электронная почта: ocean@oceanchips.ru

Web: <http://oceanchips.ru/>

Адрес: 198099, г. Санкт-Петербург, ул. Калинина, д. 2, корп. 4, лит. А