



SERIES: V78E-500-SMT | **DESCRIPTION:** NON-ISOLATED DC SWITCHING REGULATOR

FEATURES

- 500 mA of output current
- efficiency up to 95%
- SMT package
- industrial operating temp -40~+85°C
- designed to meet IEC/EN 62368-1
- industry standard footprint
- no load input current of 0.2 mA
- output short circuit protection on output



MODEL

| MODEL | input voltage ¹ | | output voltage | output current | output power | ripple & noise ² | efficiency ³ |
|----------------|----------------------------|-------------|----------------|----------------|--------------|-----------------------------|-------------------------|
| | typ (Vdc) | range (Vdc) | (Vdc) | max (mA) | max (W) | max (mVp-p) | typ (%) |
| V78E01-500-SMT | 12 | 4.75~28 | 1.5 | 500 | 0.75 | 50 | 76 |
| V78E02-500-SMT | 12 | 4.75~32 | 2.5 | 500 | 1.25 | 50 | 81 |
| V78E03-500-SMT | 24 | 4.75~36 | 3.3 | 500 | 1.65 | 50 | 86 |
| V78E05-500-SMT | 24 | 6.5~36 | 5 | 500 | 2.5 | 50 | 90 |
| V78E06-500-SMT | 24 | 8~36 | 6.5 | 500 | 3.25 | 50 | 92 |
| V78E09-500-SMT | 24 | 12~36 | 9 | 500 | 4.5 | 50 | 93 |
| V78E12-500-SMT | 24 | 15~36 | 12 | 500 | 6 | 50 | 94 |
| V78E15-500-SMT | 24 | 19~36 | 15 | 500 | 7.5 | 50 | 95 |

- Notes:
1. For input voltages higher than 30 Vdc, a 22 μ F / 50 V input capacitor is required.
 2. Tested at nominal input, 20 MHz bandwidth, with 10 μ F electrolytic and 1 μ F ceramic capacitor on the output. For 1.5~3.3 Vdc output models, tested at 20~100% load. For all other models, tested at 10~100% load. At loads below 20% for 1.5~3.3 Vdc output models, the max ripple and noise will be 100 mVp-p. At loads below 10% for all other models, the max ripple and noise will be 150 mVp-p.
 3. Measured at min V_{in} , full load.
 4. All specifications are measured at $T_a=25^\circ\text{C}$, humidity < 75%, nominal input voltage, and rated output load unless otherwise specified.

PART NUMBER KEY

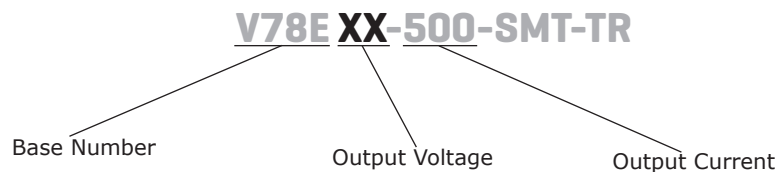

INPUT

| parameter | conditions/description | min | typ | max | units |
|--------------------------------------|---|------|------|-----|-------|
| operating input voltage ⁵ | | 4.75 | | 36 | Vdc |
| filter | capacitor filter | | | | |
| input reverse polarity protection | no | | | | |
| no-load input current | | | 0.2 | 1.5 | mA |
| remote on/off ⁶ | turn on (3.2~8 Vdc or open circuit) turn off (<0.8 Vdc) input current when switched off | | 0.03 | 0.1 | mA |

Note: 5. See Model section on page 1 for specific input voltage ranges.

6. The voltage of remote ON/OFF pin is relative to GND pin.

OUTPUT

| parameter | conditions/description | min | typ | max | units |
|--------------------------------------|--|-----|------------|------------|------------|
| maximum capacitive load ⁷ | | | | 680 | μF |
| voltage accuracy | at full load, input voltage range 1.5, 2.5, 3.3 Vdc output models all other models | | ±2 ±2 | ±4 ±3 | % % |
| line regulation | at full load, input voltage range | | ±0.2 | ±0.4 | % |
| load regulation | at 10~100 % load, input voltage range 1.5, 2.5 Vdc output models all other models | | | ±1 ±0.6 | % % |
| voltage adjustment | input voltage range | | ±10 | | %Vo |
| switching frequency | at full load, input voltage range 1.5 Vdc output model all other models | | 370 700 | | kHz kHz |
| transient recovery time | at nominal input voltage, 25% load step change | | 0.2 | 1 | ms |
| transient response deviation | at nominal input voltage, 25% load step change | | 50 | 200 | mV |
| temperature coefficient | operating temperature -40 °C to +85 °C | | | ±0.03 | %/°C |

Note: 7. The maximum capacitive load was tested at nominal input voltage, full load.

PROTECTIONS

| parameter | conditions/description | min | typ | max | units |
|--------------------------|---------------------------|-----|-----|-----|-------|
| short circuit protection | continuous, auto recovery | | | | |

SAFETY AND COMPLIANCE

| parameter | conditions/description | min | typ | max | units |
|---------------------|---|-----------|-----|-----|-------|
| safety approvals | CE | | | | |
| conducted emissions | CISPR32/EN55032, class B (external circuit required, see Figure 3-b) | | | | |
| radiated emissions | CISPR32/EN55032, class B (external circuit required, see Figure 3-b) | | | | |
| ESD | IEC/EN61000-4-2, contact ± 4kV, class B | | | | |
| radiated immunity | IEC/EN61000-4-3, 10V/m, class A | | | | |
| EFT/burst | IEC/EN61000-4-4, ± 1kV, class B (external circuit required, see Figure 3-a) | | | | |
| surge | IEC/EN61000-4-5, line-line ± 1kV, class B (external circuit required, see Figure 3-a) | | | | |
| conducted immunity | IEC/EN61000-4-6, 3 Vr.m.s, class A | | | | |
| MTBF | as per MIL-HDBK-217F, 25°C | 2,000,000 | | | hours |
| RoHS | yes | | | | |

ENVIRONMENTAL

| parameter | conditions/description | min | typ | max | units |
|-----------------------|------------------------|-----|-----|-----|-------|
| operating temperature | see derating curve | -40 | | 85 | °C |
| storage temperature | | -55 | | 125 | °C |
| storage humidity | non-condensing | | | 95 | % |

SOLDERABILITY

| parameter | conditions/description | min | typ | max | units |
|------------------|---|-----|-----|-----|-------|
| reflow soldering | see reflow profile, refer to IPC/JEDEC J-STD-020D.1 | | | 245 | °C |



MECHANICAL

| parameter | conditions/description | min | typ | max | units |
|---------------|--|-----|-----|-----|-------|
| dimensions | 15.24 x 8.50 x 8.25 [0.60 x 0.335 x 0.325 inch] | | | | mm |
| case material | black flame-retardant and heat resistant plastic (UL94V-0) | | | | |
| weight | | | 1.5 | | g |

MECHANICAL DRAWING

units: mm [inch]
 tolerance: ±0.50[±0.020]
 pin section tolerance: ±0.10[±0.004]

| PIN CONNECTIONS | |
|-----------------|---------------|
| PIN | FUNCTION |
| 1 | +VIN |
| 2 | +VIN |
| 3 | GND |
| 4 | +VOUT |
| 5 | +VOUT |
| 6 | V adj |
| 7 | GND |
| 10 | remote on/off |

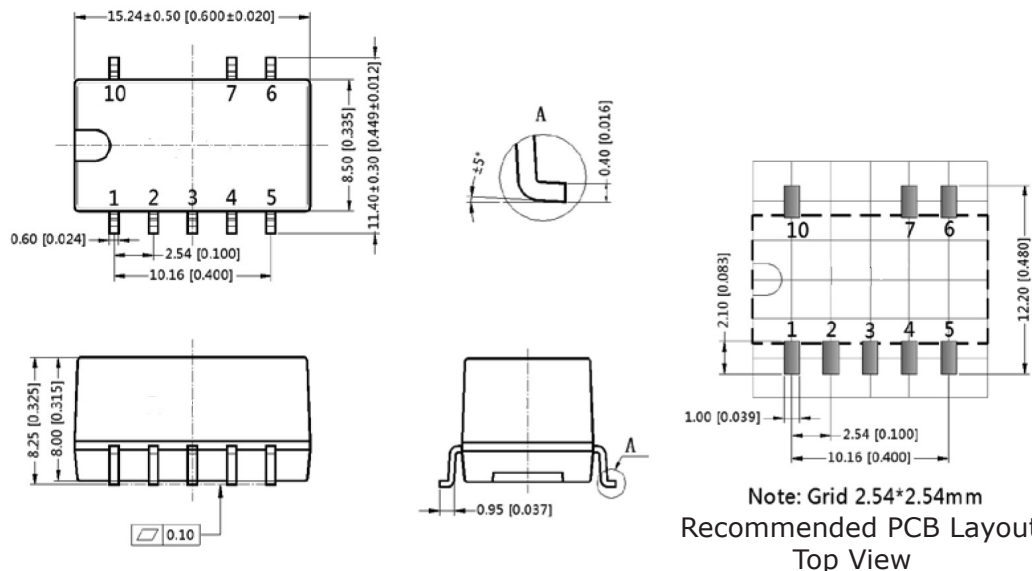

DERATING CURVE

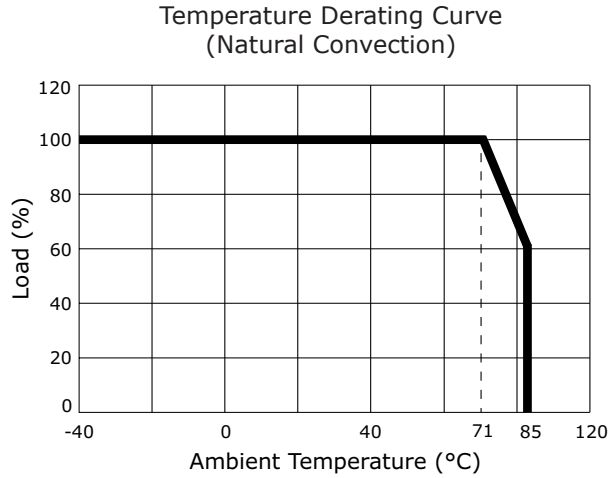

EFFICIENCY CURVES

V78E01-500-SMT Efficiency Curve
Efficiency vs. Input Voltage
(at full load)

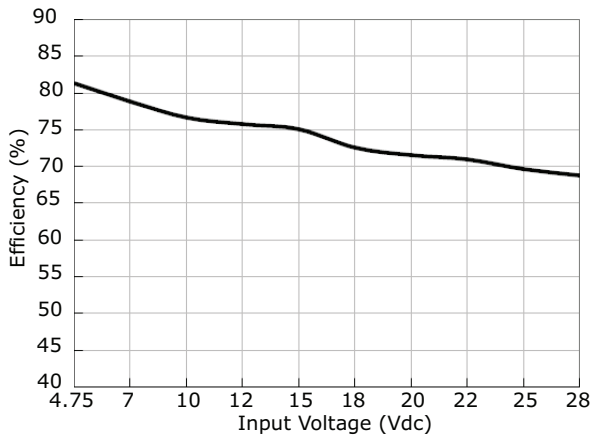

V78E01-500-SMT Efficiency Curve
Efficiency vs. Load Current
(at Vin nominal)

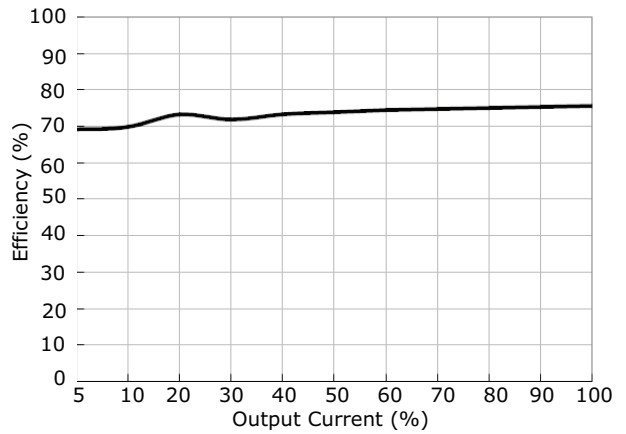

V78E02-500-SMT Efficiency Curve
Efficiency vs. Input Voltage
(at full load)

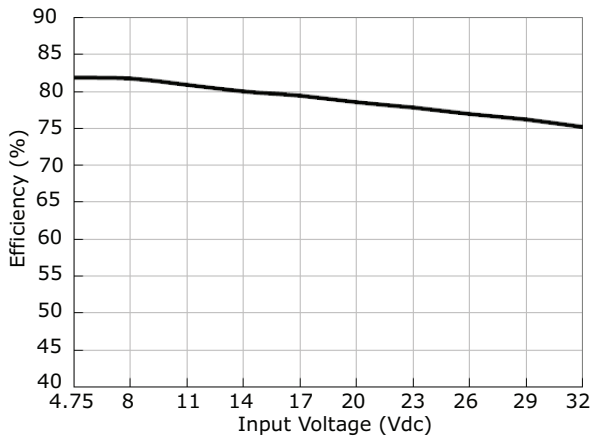

V78E02-500-SMT Efficiency Curve
Efficiency vs. Load Current
(at Vin nominal)

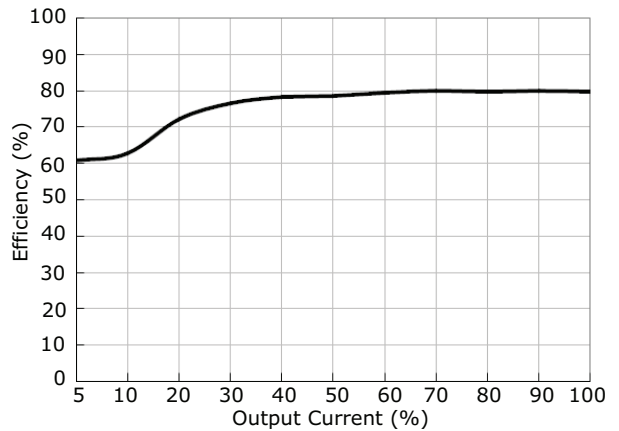

EFFICIENCY CURVES (CONTINUED)

V78E03-500-SMT Efficiency Curve
Efficiency vs. Input Voltage
(at full load)

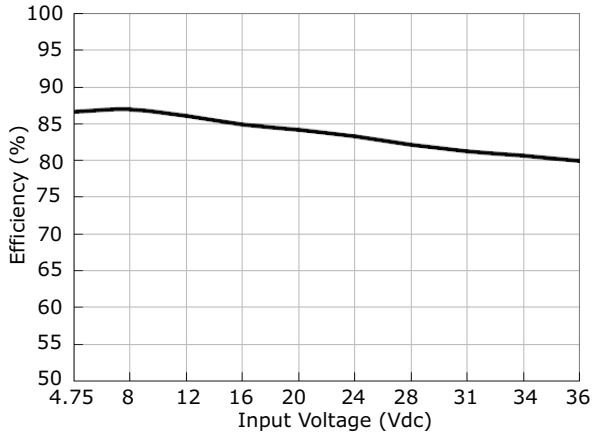

V78E03-500-SMT Efficiency Curve
Efficiency vs. Load Current
(at Vin nominal)

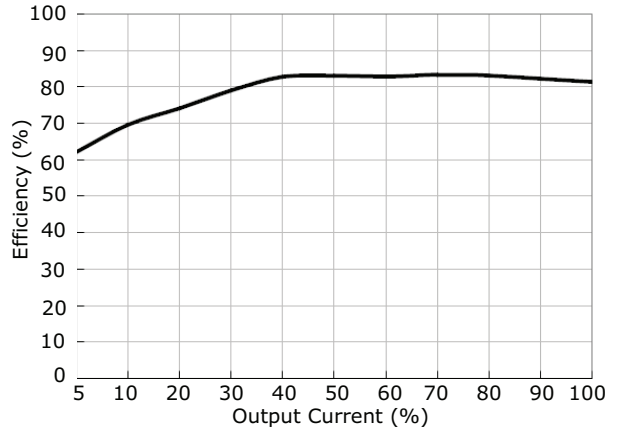

V78E05-500-SMT Efficiency Curve
Efficiency vs. Input Voltage
(at full load)

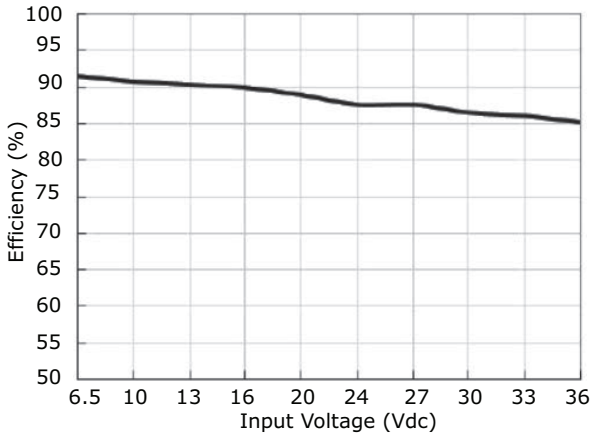

V78E05-500-SMT Efficiency Curve
Efficiency vs. Load Current
(at Vin nominal)

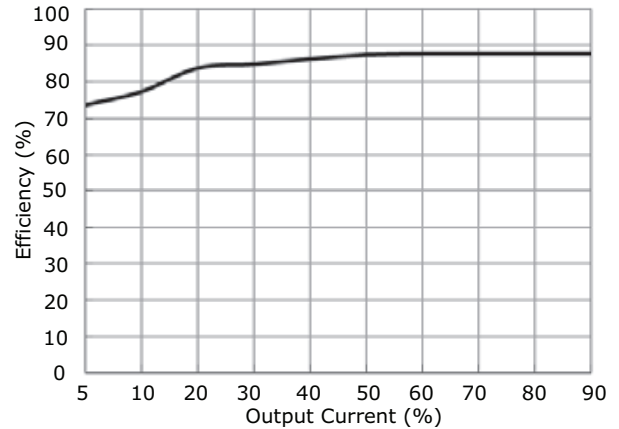

V78E06-500-SMT Efficiency Curve
Efficiency vs. Input Voltage
(at full load)

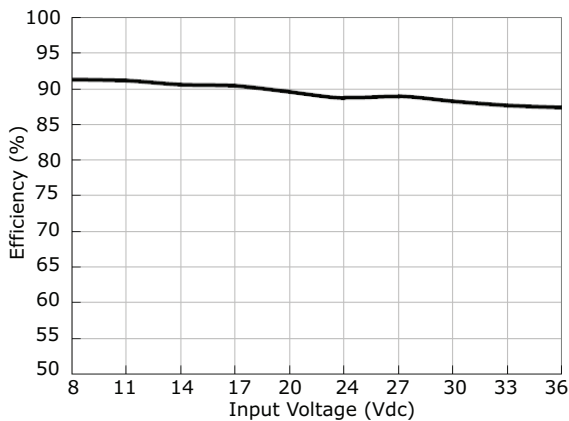

V78E06-500-SMT Efficiency Curve
Efficiency vs. Load Current
(at Vin nominal)

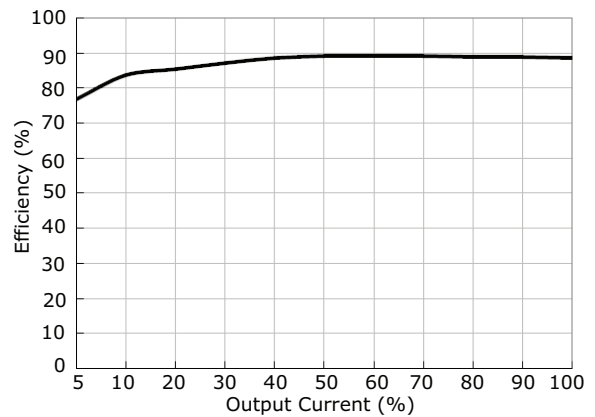

EFFICIENCY CURVES (CONTINUED)

V78E09-500-SMT Efficiency Curve
Efficiency vs. Input Voltage
(at full load)

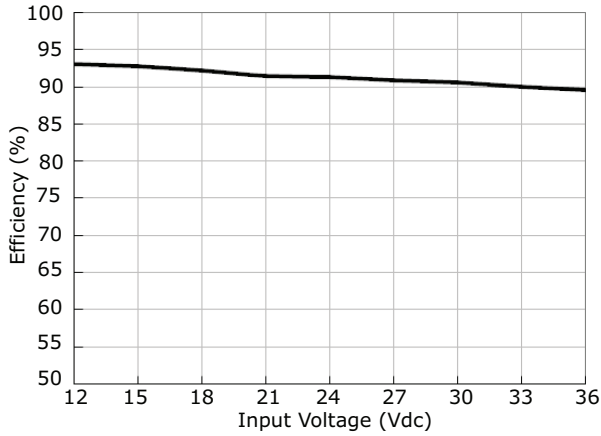

V78E09-500-SMT Efficiency Curve
Efficiency vs. Load Current
(at Vin nominal)

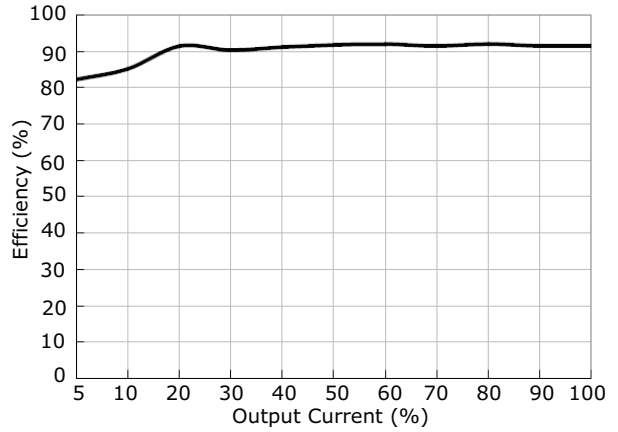

V78E12-500-SMT Efficiency Curve
Efficiency vs. Input Voltage
(at full load)

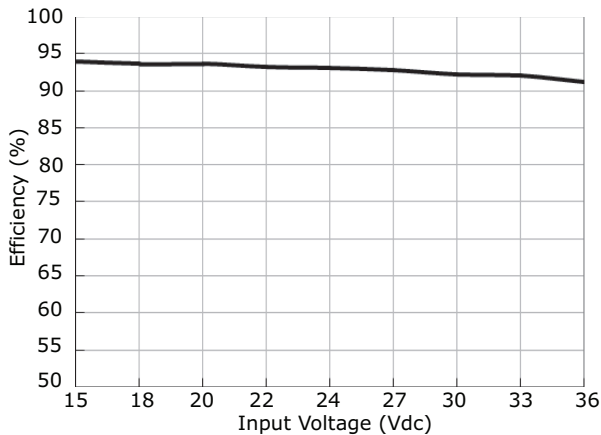

V78E12-500-SMT Efficiency Curve
Efficiency vs. Load Current
(at Vin nominal)

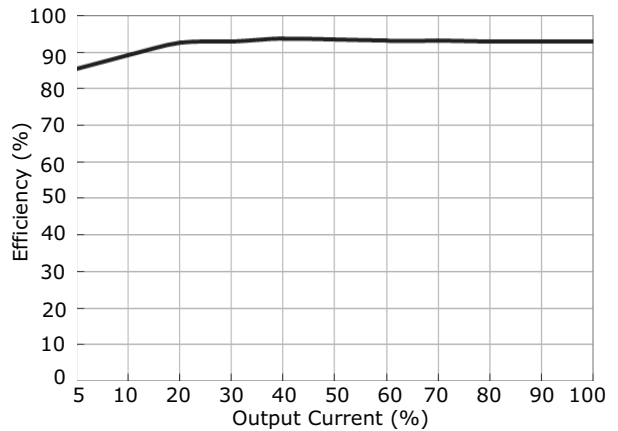

V78E15-500-SMT Efficiency Curve
Efficiency vs. Input Voltage
(at full load)

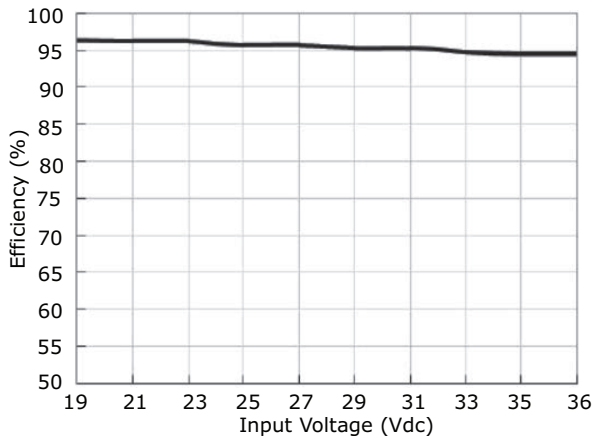

V78E15-500-SMT Efficiency Curve
Efficiency vs. Load Current
(at Vin nominal)

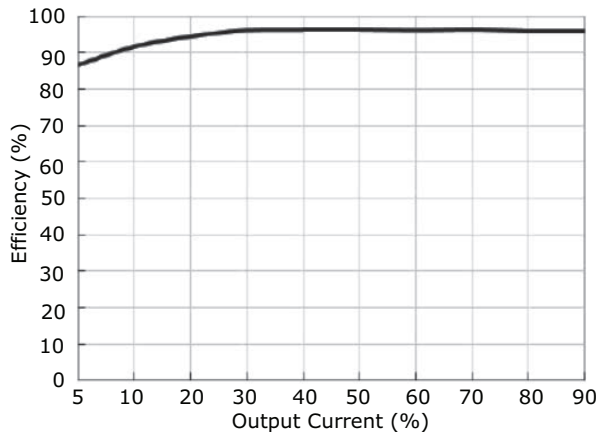

TYPICAL APPLICATION CIRCUIT

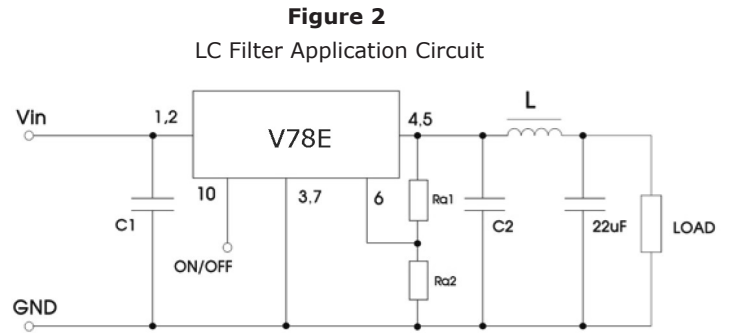
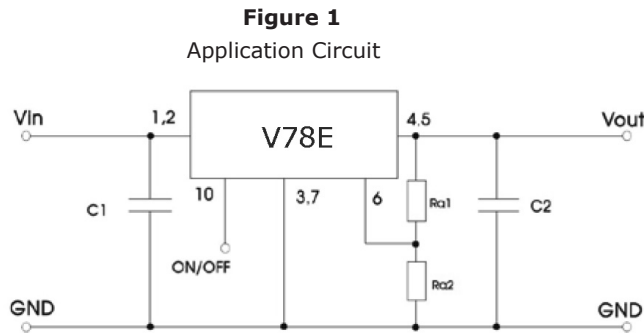

Table 1

| Model Number | C1 (ceramic capacitor) | C2 (ceramic capacitor) | Ra1/Ra2 (Vadj resistance) |
|----------------|---------------------------|---------------------------|--|
| V78E01-500-SMT | 10 µF/50 V | 22 µF/10 V | refer to Vadj resistance calculation |
| V78E02-500-SMT | 10 µF/50 V | 22 µF/10 V | |
| V78E03-500-SMT | 10 µF/50 V | 22 µF/10 V | |
| V78E05-500-SMT | 10 µF/50 V | 22 µF/16 V | |
| V78E06-500-SMT | 10 µF/50 V | 22 µF/16 V | |
| V78E09-500-SMT | 10 µF/50 V | 22 µF/25 V | |
| V78E12-500-SMT | 10 µF/50 V | 22 µF/25 V | |
| V78E15-500-SMT | 10 µF/50 V | 22 µF/25 V | |

EMC RECOMMENDED CIRCUIT

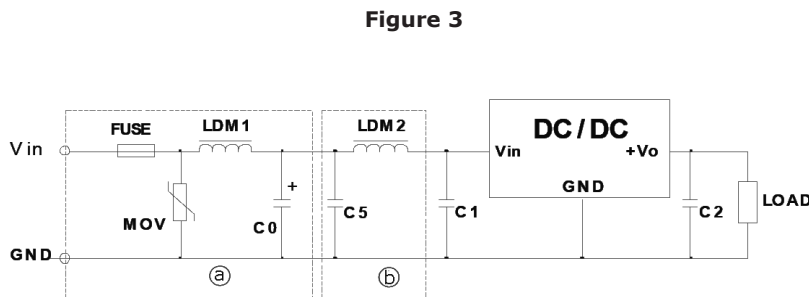

Table 2

| Recommended external circuit components | |
|---|--|
| FUSE | choose according to actual input current |
| MOV | S20K30 |
| LDM1 | 82 µH |
| C0 | 680 µF/50 V |
| C1, C2 | refer to table 1 |
| C5 | 4.7 µF/50 V |
| LDM2 | 12 µH |

Note:
 8. C1 & C2 are required and should be connected as close to the module pins as possible.
 9. C1 & C2 can be increased as needed and the use of tantalum or low ESR electrolytic capacitors would be recommended.
 10. To reduce the output ripple further, it is recommended to add an "LC" filter at the output (see figure 2) with a 10~47 µH L component.

APPLICATION NOTES

- Output voltage trimming**
Leave open if not used.

Figure 4

Application Circuit for Trim pin
(part in broken line is the interior of models)

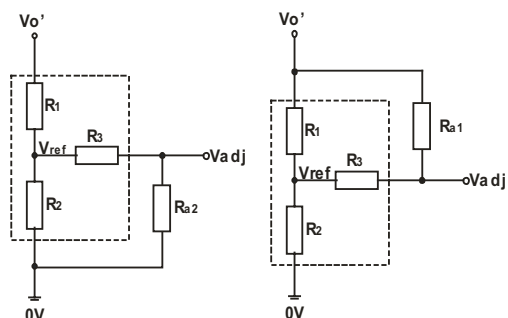

Formula for Trim Resistor

$$\text{up: } R_{a2} = \frac{a R_2}{R_2 - a} - R_3 \quad a = \frac{V_{ref}}{V_{o'} - V_{ref}} \cdot R_1$$

$$\text{down: } R_{a1} = \frac{a R_1}{R_1 - a} - R_3 \quad a = \frac{V_{o'} - V_{ref}}{V_{ref}} \cdot R_2$$

Note: Value for R1, R2, R3, and Vref refer to Table 3
Ra1/Ra2: Trim Resistor
a: User-defined parameter, no actual meanings
Vo': The trim up/down voltage

Table 3

| Vout (Vdc) | R1 (kΩ) | R2 (kΩ) | R3 (kΩ) | Vref (V) |
|-------------------|---------|---------|---------|----------|
| 1.5 ¹¹ | 7.5 | 7.5 | 15 | 0.75 |
| 2.5 | 27 | 11.858 | 51 | 0.765 |
| 3.3 | 33 | 9.9 | 47 | 0.765 |
| 5 | 75 | 13.5 | 75 | 0.765 |
| 6.5 | 75 | 10 | 51 | 0.765 |
| 9 | 51 | 4.7 | 27 | 0.765 |
| 12 | 75 | 5.1 | 27 | 0.765 |
| 15 | 82 | 4.423 | 27 | 0.765 |

Note: 11. The 1.5 Vdc output model can only be adjusted up.

PACKAGING

units: mm

Reel Size: Ø330 mm

Reel QTY: 300 pcs per tray

Carton Box Size: 400 x 365 x 255 mm

Carton Box QTY: 1,800 pcs per carton box

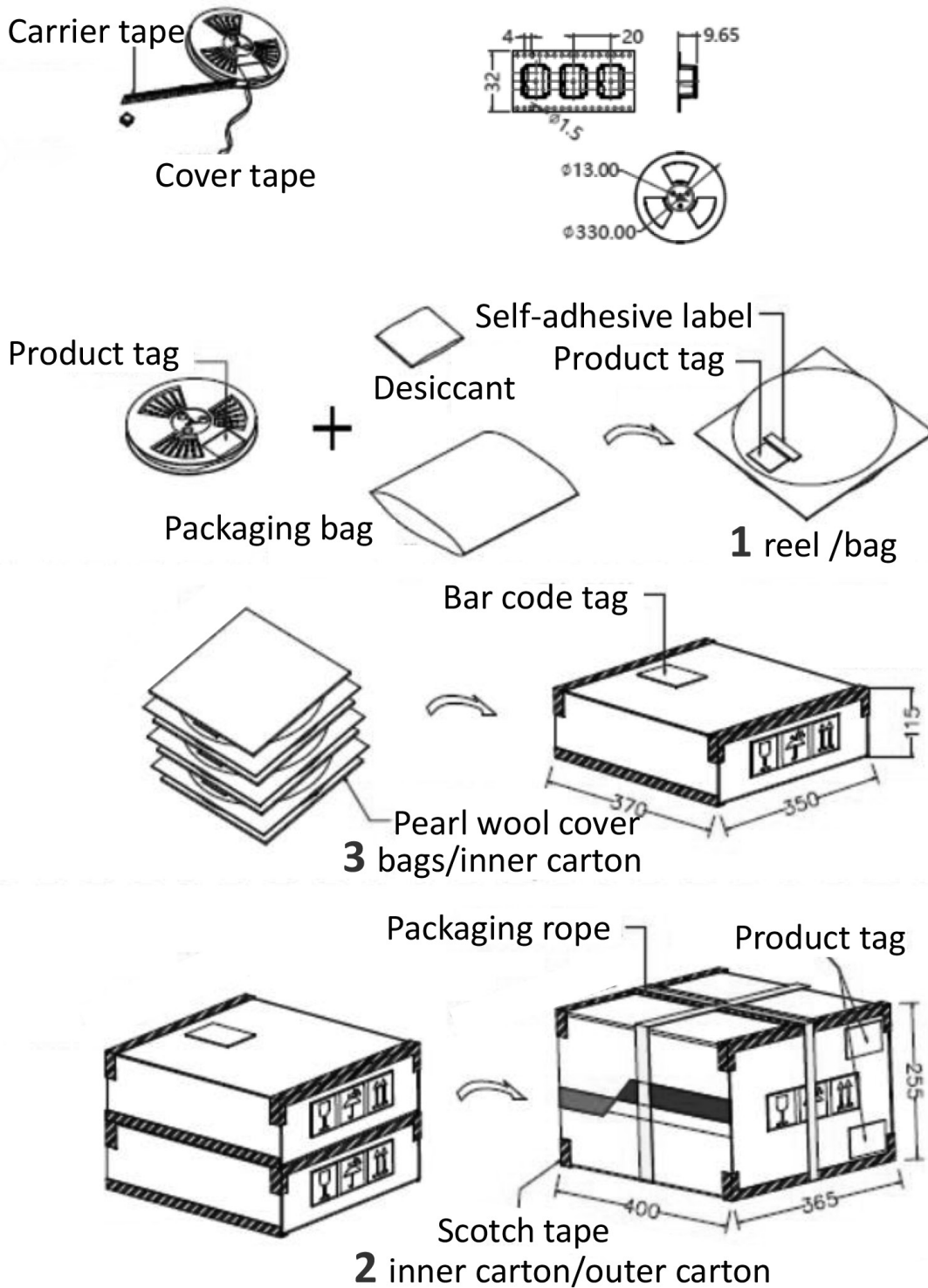

REVISION HISTORY

| rev. | description | date |
|------|-----------------|------------|
| 1.0 | initial release | 09/12/2018 |

The revision history provided is for informational purposes only and is believed to be accurate.



Headquarters
20050 SW 112th Ave.
Tualatin, OR 97062
800.275.4899

Fax 503.612.2383
cui.com
techsupport@cui.com

CUI offers a two (2) year limited warranty. Complete warranty information is listed on our website.

CUI reserves the right to make changes to the product at any time without notice. Information provided by CUI is believed to be accurate and reliable. However, no responsibility is assumed by CUI for its use, nor for any infringements of patents or other rights of third parties which may result from its use.

CUI products are not authorized or warranted for use as critical components in equipment that requires an extremely high level of reliability. A critical component is any component of a life support device or system whose failure to perform can be reasonably expected to cause the failure of the life support device or system, or to affect its safety or effectiveness.

Компания «Океан Электроники» предлагает заключение долгосрочных отношений при поставках импортных электронных компонентов на взаимовыгодных условиях!

Наши преимущества:

- Поставка оригинальных импортных электронных компонентов напрямую с производств Америки, Европы и Азии, а так же с крупнейших складов мира;
- Широкая линейка поставок активных и пассивных импортных электронных компонентов (более 30 млн. наименований);
- Поставка сложных, дефицитных, либо снятых с производства позиций;
- Оперативные сроки поставки под заказ (от 5 рабочих дней);
- Экспресс доставка в любую точку России;
- Помощь Конструкторского Отдела и консультации квалифицированных инженеров;
- Техническая поддержка проекта, помощь в подборе аналогов, поставка прототипов;
- Поставка электронных компонентов под контролем ВП;
- Система менеджмента качества сертифицирована по Международному стандарту ISO 9001;
- При необходимости вся продукция военного и аэрокосмического назначения проходит испытания и сертификацию в лаборатории (по согласованию с заказчиком);
- Поставка специализированных компонентов военного и аэрокосмического уровня качества (Xilinx, Altera, Analog Devices, Intersil, Interpoint, Microsemi, Actel, Aeroflex, Peregrine, VPT, Syfer, Eurofarad, Texas Instruments, MS Kennedy, Miteq, Cobham, E2V, MA-COM, Hittite, Mini-Circuits, General Dynamics и др.);

Компания «Океан Электроники» является официальным дистрибьютором и эксклюзивным представителем в России одного из крупнейших производителей разъемов военного и аэрокосмического назначения «JONHON», а так же официальным дистрибьютором и эксклюзивным представителем в России производителя высокотехнологичных и надежных решений для передачи СВЧ сигналов «FORSTAR».



JONHON

«JONHON» (основан в 1970 г.)

Разъемы специального, военного и аэрокосмического назначения:

(Применяются в военной, авиационной, аэрокосмической, морской, железнодорожной, горно- и нефтедобывающей отраслях промышленности)

«FORSTAR» (основан в 1998 г.)

ВЧ соединители, коаксиальные кабели, кабельные сборки и микроволновые компоненты:

(Применяются в телекоммуникациях гражданского и специального назначения, в средствах связи, РЛС, а так же военной, авиационной и аэрокосмической отраслях промышленности).



Телефон: 8 (812) 309-75-97 (многоканальный)

Факс: 8 (812) 320-03-32

Электронная почта: ocean@oceanchips.ru

Web: <http://oceanchips.ru/>

Адрес: 198099, г. Санкт-Петербург, ул. Калинина, д. 2, корп. 4, лит. А