

PLEASE CHECK WWW.MOLEX.COM FOR LATEST PART INFORMATION

Part Number: **0740581003**
Status: **Active**
Overview: vhdm
Description: 2.00mm (.079") Pitch VHDM® Board-to-Board Backplane Header, Vertical, 6-Row, Pin End Version, 60 Circuits, Pin Length 4.75mm (.187")

Documents:

[Drawing \(PDF\)](#) [RoHS Certificate of Compliance \(PDF\)](#)

Agency Certification

UL E29179

General

Product Family Backplane Connectors
 Series [74058](#)
 Application Backplane
 Application Tooling Documents [Tooling Manual](http://www.molex.com/pdm_docs/ats/TM-622010999.pdf)
 Comments No Keying Position
 Component Type PCB Header
 Overview [vhdm](#)
 Product Name VHDM®
 Style N/A

Physical

Circuits (Loaded) 60
 Circuits (maximum) 60
 Color - Resin Black
 Durability (mating cycles max) 200
 First Mate / Last Break No
 Flammability 94V-0
 Guide to Mating Part Yes
 Keying to Mating Part None
 Material - Metal Beryllium Copper, High Performance Alloy (HPA), Stainless Steel
 Material - Plating Mating Gold
 Material - Plating Termination Tin-Lead
 Material - Resin High Temperature Thermoplastic
 Number of Columns N/A
 Number of Pairs Open Pin Field
 Number of Rows 6
 Orientation Vertical
 PC Tail Length (in) 0.098 In
 PC Tail Length (mm) 2.50 mm
 PCB Locator No
 PCB Retention None
 PCB Thickness Recommended (in) 0.071 In
 PCB Thickness Recommended (mm) 1.80 mm
 Packaging Type Tube
 Pitch - Mating Interface (in) 0.079 In
 Pitch - Mating Interface (mm) 2.00 mm
 Pitch - Term. Interface (in) 0.039 In
 Pitch - Term. Interface (mm) 1.00 mm
 Plating min: Mating (µin) 30
 Plating min: Mating (µm) 0.75
 Plating min: Termination (µin) 30

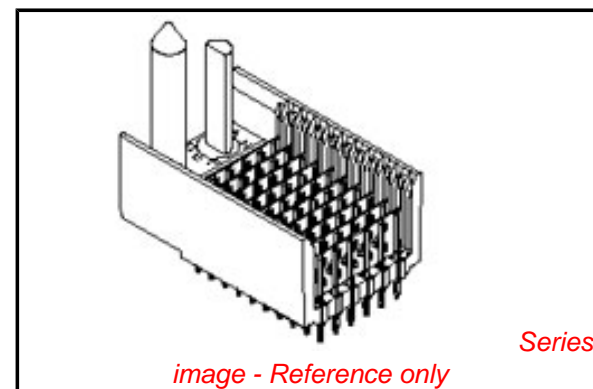

EU RoHS

Not RoHS Compliant
REACH SVHC
Not Reviewed
Halogen-Free
Status
Not Reviewed

China RoHS



Need more information on product environmental compliance?

Email productcompliance@molex.com
 For a multiple part number RoHS Certificate of Compliance, [click here](#)

Please visit the [Contact Us](#) section for any non-product compliance questions.

Search Parts in this Series

[74058Series](#)

Mates With

[74030 VHDM® Board-to-Board Daughtercard Receptacle](#)

Application Tooling | FAQ

Tooling specifications and manuals are found by selecting the products below. Crimp Height Specifications are then contained in the Application Tooling Specification document.

Global

Description	Product #
Flat Rock Tooling for Pneumatic Press	0622013700
VHDM® Insertion Module for Advanced Mate Signal Header, 6 Row by 11 Wide, 20.00mm (.787")	0622011101
VHDM® Signal Pin Inserter Repair Tool	0622015700

Plating min: Termination (µm)	0.75
Polarized to PCB	Yes
Stackable	No
Surface Mount Compatible (SMC)	Yes
Temperature Range - Operating	105°C
Termination Interface: Style	Through Hole - Compliant Pin

Electrical

Current - Maximum per Contact	1A
Data Rate	3.125 Gbps
Real Signals (per 25mm)	75
Shield Type	Ground Plane Shield
Shielded	Yes
Voltage - Maximum	120V AC (RMS)/DC

Material Info

Reference - Drawing Numbers

Sales Drawing	SD-74058-002
---------------	--------------

VHDM and Very High Density Metric are trademarks of Amphenol Corporation

VHDM® 6 Row Pin and Shield Repair Tool	0622015800
VHDM® 6 Row Shield Extraction Tool	0622016000
VHDM® Insertion Module for Advanced Mate Signal Header, 6 Row by 10 Wide, 20.00mm (.787")	0622020203
VHDM® Insertion Module for Advanced Mate Signal Header, 6 Row by 10 Wide, 20.00mm (.787")	0622020207

This document was generated on 05/19/2010

PLEASE CHECK WWW.MOLEX.COM FOR LATEST PART INFORMATION

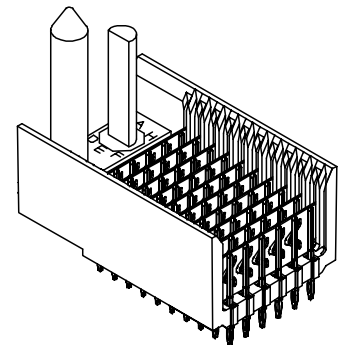
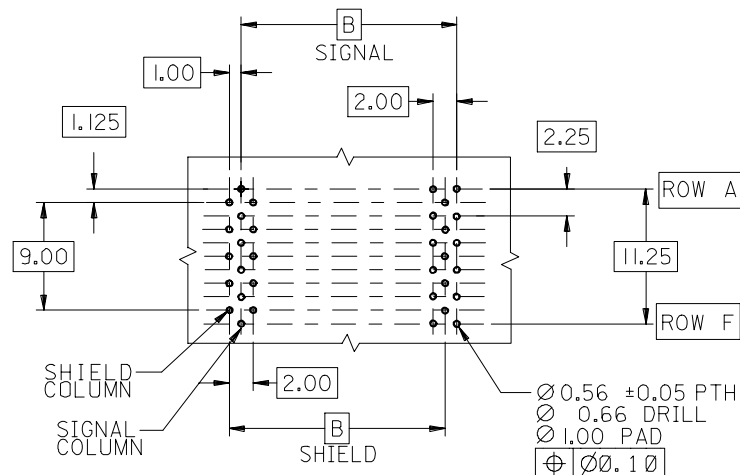
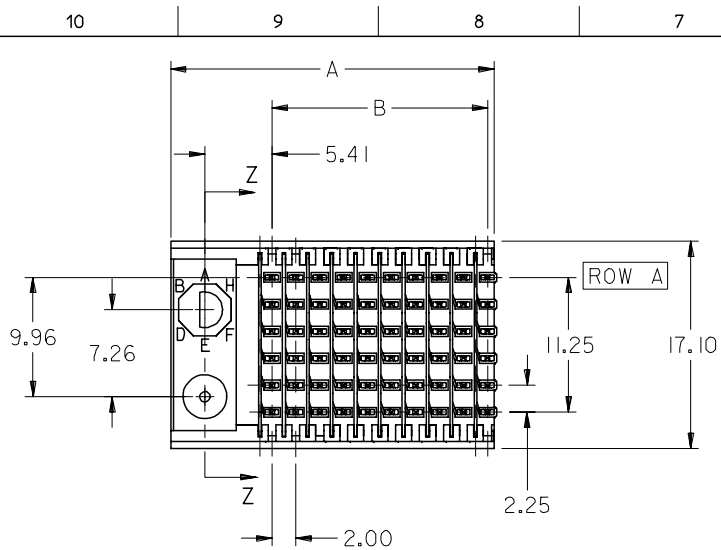

BACKPLANE HOLE PATTERN
RECOMMENDED DIMENSIONS

NOTES:

- MATERIALS:
HOUSING - LIQUID CRYSTAL POLYMER (LCP),
GLASS-FILLED, UL 94V-0, COLOR: BLACK
SIGNAL PIN & SHIELD - COPPER ALLOY
- FINISHES:
CONTACT AREA: SELECTIVE GOLD (Au)
PCB TAILS: SELECTIVE TIN/LEAD (Sn/Pb)
OR SELECTIVE MATTE TIN (Sn)
NICKEL (Ni) OVERALL.
- THIS PART CONFORMS TO MOLEX PRODUCT SPECIFICATION PS-74031-999
- FOR MIXED CONTACT LENGTHS CONSULT MOLEX FOR AVAILABILITY
- FOR SPECIFIC MATERIAL NUMBERS & MATING INFORMATION REFER TO SHEET 2
- PACKAGE PER PK-74058-003
- EITHER MARK PART WITH PART NUMBER & DATE CODE APPROXIMATELY WHERE SHOWN OR PLACE LABEL ON THE TUBE.

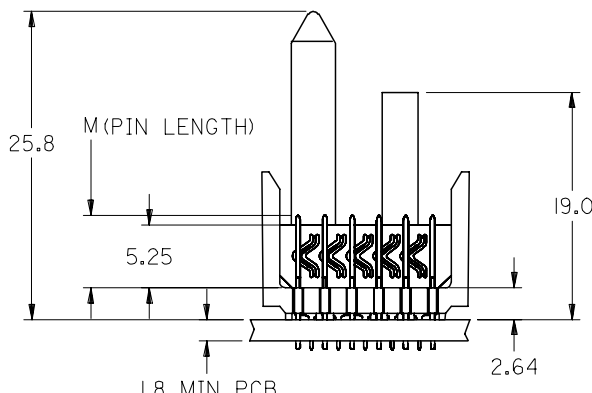
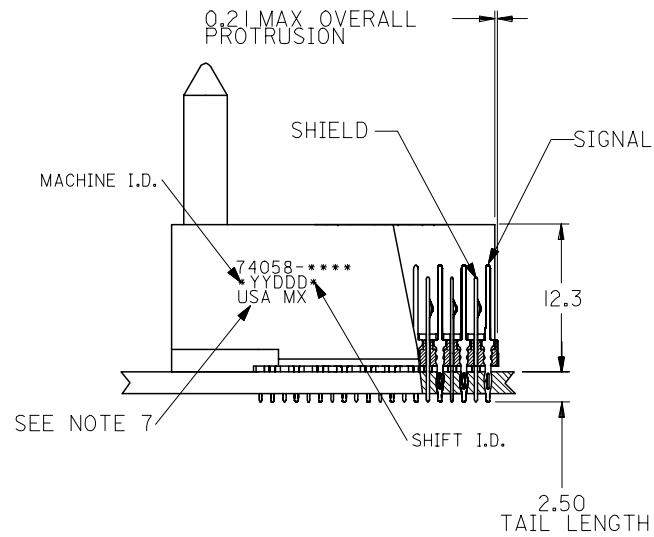

ADD LEADFREE PINS EC NO: UCP2006-0079 DRWN: KMILVEY CHKD: 2005/07/21 APPR: SREED 2005/07/22	DESCRIPTION REV	QUALITY SYMBOLS	GENERAL TOLERANCES (UNLESS SPECIFIED)		DIMENSION STYLE	SCALE	DESIGN UNITS	THIRD ANGLE PROJECTION	
		$\nabla=0$ $\nabla=0$	mm	INCH	MM ONLY	2.5:1	METRIC		
		4 PLACES ± --- ± --- 3 PLACES ± --- ± --- 2 PLACES ± --- ± --- 1 PLACE ± --- ± --- ANGULAR ±1/2°	DRAWN BY	DATE	TITLE	VHM 6 ROW SIGNAL END BACKPLANE SALES ASSEMBLY MOLEX INCORPORATED			
		DRAFT WHERE APPLICABLE MUST REMAIN WITHIN DIMENSIONS	MWANG	1998/11/09	SD-74058-002				
		CHECKED BY	DATE	MATERIAL NO.	DOCUMENT NO.	SHEET NO.			
		JLAURX	1998/11/09	SEE SHEET 2	SD-74058-002	1 OF 2			
		APPROVED BY	DATE	THIS DRAWING CONTAINS INFORMATION THAT IS PROPRIETARY TO MOLEX INCORPORATED AND SHOULD NOT BE USED WITHOUT WRITTEN PERMISSION					
		CBIXLER	1998/11/09						

10 9 8 7 6 5 4 3 2 1

M/N 74058-()	-**0*	-**1*	-**2*	-**3*	-**4*	-**5*	-**6*	-**7*	-**8*
KEYING PIN ORIENTATION	O	A	B	C	D	E	F	G	H

74058 * * * *

NUMBER OF COLUMNS/PLATING
 10 = 10 COLUMN TIN/LEAD
 25 = 25 COLUMN TIN/LEAD
 90 = 10 COLUMN MATTE TIN
 85 = 25 COLUMN MATTE TIN

CONTACT LOAD
 (PIN LENGTH)
 1 & 6 = 4.75
 2 & 7 = 6.25
 3 & 8 = 4.75
 4 & 9 = 5.15

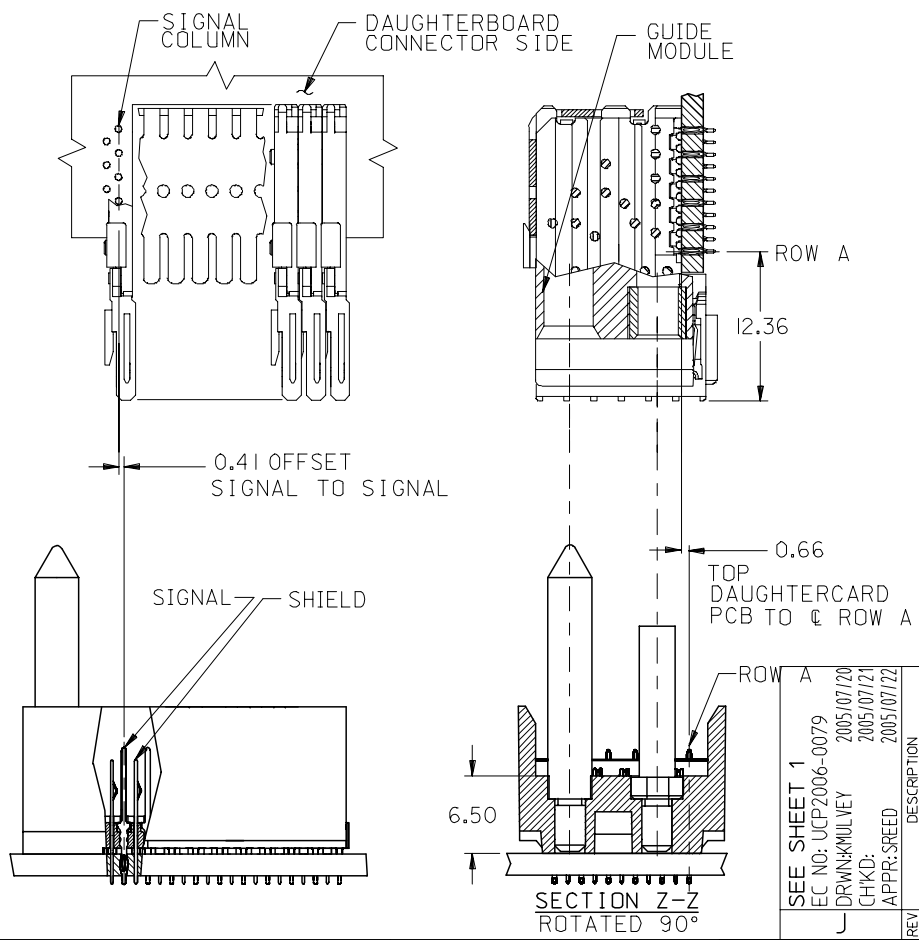

PART NUMBER	COLUMN	NUMBER OF SIGNAL PIN	NUMBER OF SHIELD	A	B	M	Au (um) THICKNESS	Sn (um) THICKNESS
74058-*0*1	10	60	10	27.00	18.00	4.75	0.76	0.76-1.52
74058-*0*6							1.27	
74058-*5*1	25	150	25	57.00	48.00	6.25	0.76	
74058-*5*6							1.27	
74058-*0*2	10	60	10	27.00	18.00	4.25	0.76	
74058-*0*7							1.27	
74058-*5*2	25	150	25	57.00	48.00	5.15	0.76	
74058-*5*7							1.27	
74058-*0*3	10	60	10	27.00	18.00	4.75	0.76	
74058-*0*8							1.27	
74058-*5*3	25	150	25	57.00	48.00	6.25	0.76	
74058-*5*8							1.27	
74058-*0*4	10	60	10	27.00	18.00	5.15	0.76	
74058-*0*9							1.27	
74058-*5*4	25	150	25	57.00	48.00	4.75	0.76	
74058-*5*9							1.27	

1b_frame_B_P_ME_T
Rev. D 2004/04/02

9 8 7 6 5 4 3 2 1

SEE SHEET 1
 EC NO: UCP2006-0079
 DRWNG: MILEY 2005/07/20
 CHKD: 2005/07/21
 APPR: SREED 2005/07/22

QUALITY SYMBOLS
 ▽=0
 ▽=0

GENERAL TOLERANCES (UNLESS SPECIFIED)

	mm	INCH
4 PLACES	± ---	± ---
3 PLACES	± ---	± ---
2 PLACES	± ---	± ---
1 PLACE	± ---	± ---

ANGULAR ±1/2°

DRAFT WHERE APPLICABLE
 MUST REMAIN
 WITHIN DIMENSIONS

DIMENSION STYLE
 MM ONLY

DRAWN BY DATE
 MWANG 1998/11/09

CHECKED BY DATE
 JLAURX 1998/11/09

APPROVED BY DATE
 CBIXLER 1998/11/09

MATERIAL NO.
 SEE CHART

SCALE
 2.5:1

DESIGN UNITS
 METRIC

THIRD ANGLE PROJECTION

VHDM 6 ROW
 SIGNAL END BACKPLANE
 SALES ASSEMBLY

MOLEX MOLEX INCORPORATED

DOCUMENT NO.
 SD-74058-002

SHEET NO.
 2 OF 2

THIS DRAWING CONTAINS INFORMATION THAT IS PROPRIETARY TO MOLEX INCORPORATED AND SHOULD NOT BE USED WITHOUT WRITTEN PERMISSION

Компания «Океан Электроники» предлагает заключение долгосрочных отношений при поставках импортных электронных компонентов на взаимовыгодных условиях!

Наши преимущества:

- Поставка оригинальных импортных электронных компонентов напрямую с производств Америки, Европы и Азии, а так же с крупнейших складов мира;
- Широкая линейка поставок активных и пассивных импортных электронных компонентов (более 30 млн. наименований);
- Поставка сложных, дефицитных, либо снятых с производства позиций;
- Оперативные сроки поставки под заказ (от 5 рабочих дней);
- Экспресс доставка в любую точку России;
- Помощь Конструкторского Отдела и консультации квалифицированных инженеров;
- Техническая поддержка проекта, помощь в подборе аналогов, поставка прототипов;
- Поставка электронных компонентов под контролем ВП;
- Система менеджмента качества сертифицирована по Международному стандарту ISO 9001;
- При необходимости вся продукция военного и аэрокосмического назначения проходит испытания и сертификацию в лаборатории (по согласованию с заказчиком);
- Поставка специализированных компонентов военного и аэрокосмического уровня качества (Xilinx, Altera, Analog Devices, Intersil, Interpoint, Microsemi, Actel, Aeroflex, Peregrine, VPT, Syfer, Eurofarad, Texas Instruments, MS Kennedy, Miteq, Cobham, E2V, MA-COM, Hittite, Mini-Circuits, General Dynamics и др.);

Компания «Океан Электроники» является официальным дистрибьютором и эксклюзивным представителем в России одного из крупнейших производителей разъемов военного и аэрокосмического назначения «JONHON», а так же официальным дистрибьютором и эксклюзивным представителем в России производителя высокотехнологичных и надежных решений для передачи СВЧ сигналов «FORSTAR».



JONHON

«JONHON» (основан в 1970 г.)

Разъемы специального, военного и аэрокосмического назначения:

(Применяются в военной, авиационной, аэрокосмической, морской, железнодорожной, горно- и нефтедобывающей отраслях промышленности)

«FORSTAR» (основан в 1998 г.)

ВЧ соединители, коаксиальные кабели, кабельные сборки и микроволновые компоненты:

(Применяются в телекоммуникациях гражданского и специального назначения, в средствах связи, РЛС, а так же военной, авиационной и аэрокосмической отраслях промышленности).



Телефон: 8 (812) 309-75-97 (многоканальный)

Факс: 8 (812) 320-03-32

Электронная почта: ocean@oceanchips.ru

Web: <http://oceanchips.ru/>

Адрес: 198099, г. Санкт-Петербург, ул. Калинина, д. 2, корп. 4, лит. А