

AS5172A / AS5172B

High-Resolution On-Axis Magnetic Angular Position Sensor with PSI5 Output

General Description

The AS5172 is a magnetic position sensor with a high resolution 12-bit PSI5 output according PSI5 specification Version 1.3 and 2.1.

Based on a Hall sensor technology, this device measures the orthogonal component of the flux density (B_z) over a full-turn rotation and compensates for external stray magnetic fields with a robust architecture based on a 14-bit sensor array and analog front-end (AFE). A sub-range can be programmed to achieve the best resolution for the application. To measure the angle, only a simple two-pole magnet rotating over the center of the package is required. The magnet may be placed above or below the device. The absolute angle measurement provides an instant indication of the magnet's angular position. The AS5172 operates up to a voltage of 16.5V and is protected against overvoltage up to +20V. In addition, the supply pins are protected against reverse polarity up to -18V.

Programmability over the VDD pin reduces the number of pins on the application connector.

The AS5172 is available in a TSSOP14 package and in a SIP package.

The SIP package (System in Package) has integrated the AS5172 sensor die together with the decoupling capacitors necessary to pass system level ESD and EMC requirements. No additional components and PCB on the sensor side are needed.

The product is defined as SEooC (Safety Element out of Context) according ISO26262.

The product is fully system level EMC and ESD tested according OEM standards.

Ordering Information and Content Guide appear at end of datasheet.

Key Benefits and Features

The benefits and features of this device are listed below:

Figure 1:
Added Value of Using AS5172

Benefits	Features
<ul style="list-style-type: none"> Resolve small angular excursion with high accuracy 	<ul style="list-style-type: none"> 12-bit resolution @90° minimum arc
<ul style="list-style-type: none"> Accurate angle measurement 	<ul style="list-style-type: none"> Low output noise, low inherent INL
<ul style="list-style-type: none"> Higher durability and lower system costs (no shield needed) 	<ul style="list-style-type: none"> Magnetic stray field immunity
<ul style="list-style-type: none"> Enabler for safety critical applications 	<ul style="list-style-type: none"> Functional safety, diagnostics
<ul style="list-style-type: none"> Suitable for automotive applications 	<ul style="list-style-type: none"> AEC-Q100 Grade 0 qualified (AS5172B) AEC-Q100 Grade 1 qualified (AS5172A)
<ul style="list-style-type: none"> SIP Package 	<ul style="list-style-type: none"> System cost reduction – no PCB and additional components are needed

Applications

The AS5172 is ideal for automotive applications like brake and gas pedals, throttle valve and tumble flaps, steering angle sensors, chassis ride, EGR, fuel-level measurement systems, 2/4WD switch, and contactless potentiometers.

Block Diagram

The functional blocks of this device are shown below:

Figure 2:
Functional Blocks of the AS5172

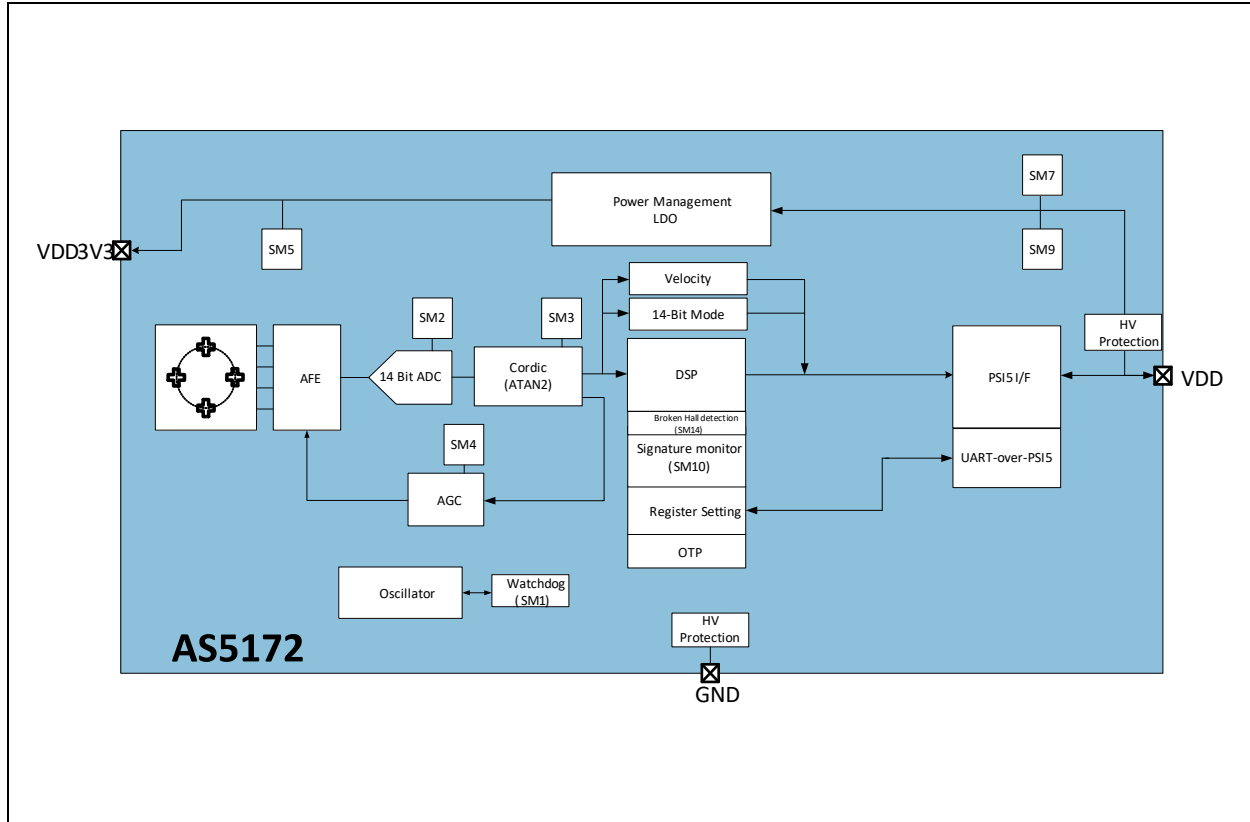

Note(s):

1. Detailed safety mechanism information can be found in chapter [Diagnostic](#).

Pin Assignments

Pin Diagram

Figure 3:
AS5172B Pin Assignment (Top View, TSSOP14)

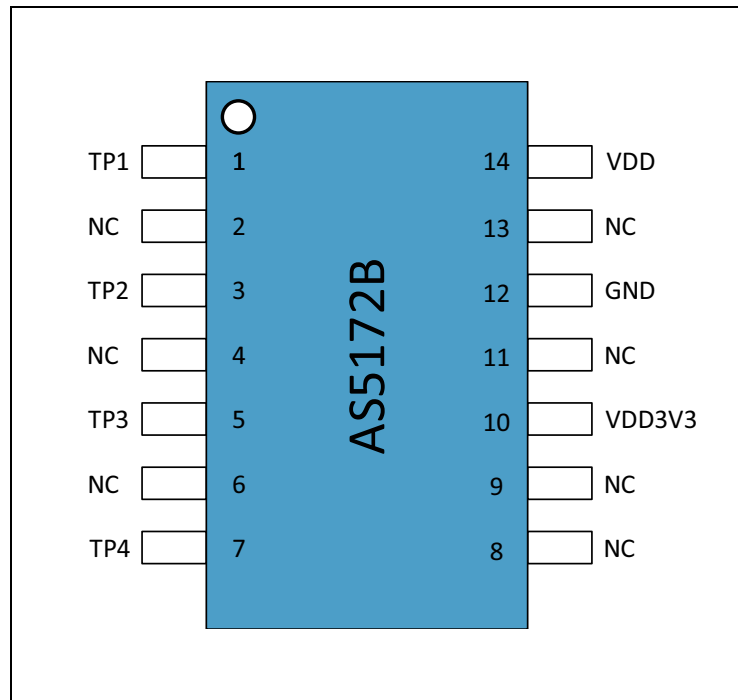

Figure 4:
AS5172B Pin Description

Pin Number	Name	Type	Description
1	TP1	Test pin	Connected to GND in application
2	NC	Not connected	Connected to GND in application
3	TP2	Test Pin	Connected to GND in application
4	NC	Not connected	Connected to GND in application
5	TP3	Test Pin	Connected to GND in application
6	NC	Not connected	Connected to GND in application
7	TP4	Test Pin	Connected to GND in application
8	NC	Not connected	Connected to GND in application
9	NC	Not connected	Connected to GND in application
10	VDD3V3	Supply	Requires a 470nF capacitor to GND

Pin Number	Name	Type	Description
11	NC	Not connected	Connected to GND in application
12	GND	Supply	Ground
13	NC	Not connected	Connected to GND in application
14	VDD	Supply	Supply/PSI5 interface/UART-over-PSI5 programming Requires a 15nF capacitor to GND

Figure 5:
AS5172A in SIP Package

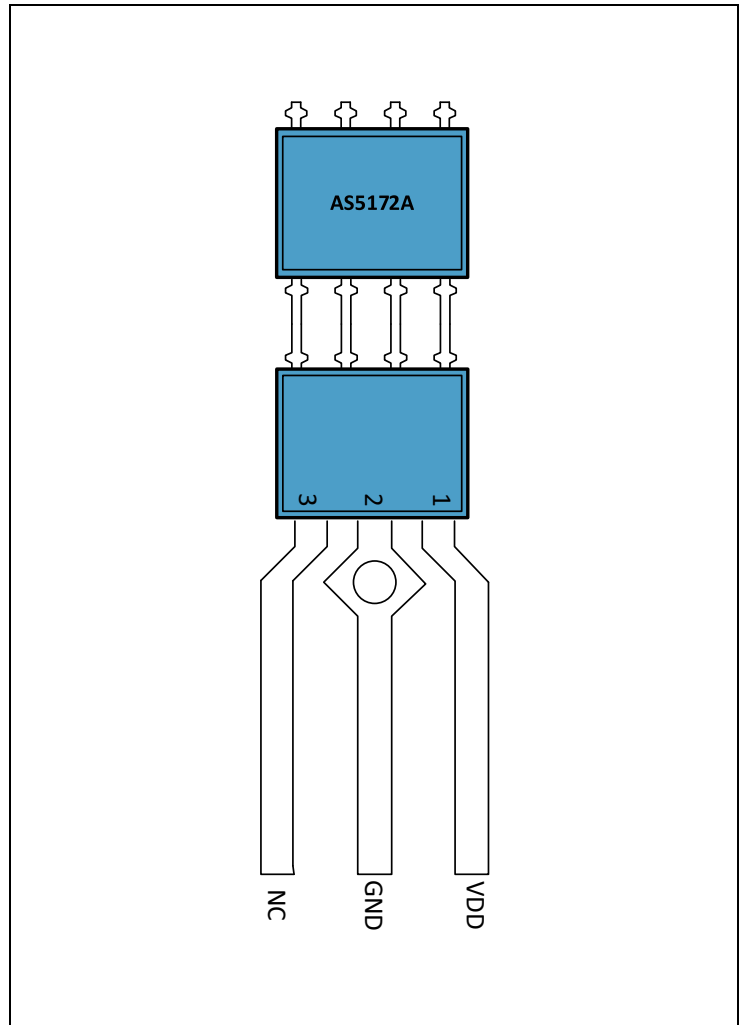

Figure 6:
AS5172A Pin Description

Pin Number	Name	Type	Description
1	VDD	Supply	Supply/PSI5 interface/UART-over-PSI5 programming
2	GND	Supply	Ground
3	NC	Not connected	Left open in application

Absolute Maximum Ratings

Stresses beyond those listed under [Absolute Maximum Ratings](#) may cause permanent damage to the device. These are stress ratings only. Functional operation of the device at these or any other conditions beyond those indicated under [Operating Conditions](#) is not implied. Exposure to absolute maximum rating conditions for extended periods may affect device reliability.

Figure 7:
Absolute Maximum Ratings

Symbol	Parameter	Min	Max	Units	Comments
Electrical Parameters					
VDD	DC Supply Voltage at VDD pin	-18	20	V	Not operational
VREGOUT	DC Voltage at the VDD3V3 pin	-0.3	5	V	
ISCR	Input Current (latch-up immunity)	±100		mA	AEC-Q100-004
Continuous Power Dissipation (T_{AMB} = 70°C)					
P _{T_Tssop}	Continuous Power Dissipation		377	mW	
P _{T_SIP}	Continuous Power Dissipation		377	mW	
Electrostatic Discharge					
ESD _{HBM on all}	Electrostatic Discharge HBM	±2		kV	AEC-Q100-002
ESD _{HBM on TSSOP}	On VDD and GND	±4		kV	AEC-Q100-002
ESD _{HBM on SIP}	On VDD and GND	±8		kV	AEC-Q100-002

Symbol	Parameter	Min	Max	Units	Comments
Temperature Ranges and Storage Conditions					
T_{AMB}	Operating Temperature Range	-40	125	°C	AS5172A ambient temperature
T_{AMB_LM}	Operating Temperature Range	-40	150	°C	AS5172B ambient temperature
T_{aProg}	Programming Temperature	5	45	°C	Programming@ room temperature (25°C ± 20°C)
T_{STRG}	Storage Temperature Range	-55	125	°C	
T_{BODY}	Package Body Temperature		260	°C	The reflow peak soldering temperature (body temperature) is specified according to IPC/JEDEC J-STD-020 "Moisture/Reflow Sensitivity Classification for Non-hermetic Solid State Surface Mount Devices." The lead finish for Pb-free leaded packages is "Matte Tin" (100% Sn)
RH_{NC}	Relative Humidity (non-condensing)	5	85	%	
MSL	Moisture Sensitivity Level	3			Represents a maximum floor life time of 168 hours

System Electrical and Timing Characteristics

All limits are guaranteed. The parameters with min and max values are guaranteed with production tests or SQC (Statistical Quality Control) methods.

All in this datasheet defined tolerances for external components need to be assured over the whole operation conditions range and also over lifetime.

Overall Condition:

T_{AMB} = -40°C to 125°C for AS5172A;

T_{AMB} = -40°C to 150°C for AS5172B;

VDD = 4V – 12V (sync pulse voltage not included);

Components spec; unless otherwise noted

Figure 8:
Operating Conditions

Symbol	Parameter	Conditions	Min	Typ	Max	Unit
VDD	Positive Supply Voltage	Static condition	4		12	V
VDD_Rx	Positive Supply Voltage	Dynamic condition	4		16.5	V
VDD3	Regulator Voltage		3.3	3.45	3.6	V
IDD	Current Consumption	No programming and no PSI5 communication	11	15	19	mA
IDDProg	Current Consumption	During programming		80		mA
IDDProgUN	Current Consumption of Unprogrammed Device	Unprogrammed device @ $T_{AMB} = 25^{\circ}\text{C} \pm 10^{\circ}\text{C}$			49	mA
IDD max	Current Consumption	IDD + IS_Common			49	mA
IS_Common	Sink Current (common mode)		22	26	30	mA
IS_low power mode		Sink current (low power mode)	11	13	15	mA
IDD_D	Current Drift of IS in Low Power Mode		-4		4	mA
IDD_DRate	Current Drift Rate	Not tested			1	mA/s
TSUP	Start-Up Time, With $\pm 2\text{mA}$ Tolerance in Respect to the Trimmed ILO Value (IL)	Functional mode			5	ms
PSI5_T	Fall/Rise Time of the Current Slope	Programmed in production	300	500	700	ns
PSI5_TBITL	Bit Time 125kbit/s Mode	Not tested - Guaranteed by Design	7.6	8.0	8.4	μs
PSI5_TBITH	Bit Time 189kbit/s Mode	Not tested - Guaranteed by Design	5.0	5.3	5.6	μs
PSI5_MSR	Mark/Space Ratio	$(t_{fall,80\%} - t_{rise,20\%})/PSI5_TBIT$ or $(t_{fall,20\%} - t_{rise,80\%})/PSI5_TBIT$ Programmed in production	47	50	53	%

Electrical System Characteristics

T_{AMB} = -40°C to 125°C for AS5172A;

T_{AMB} = -40°C to 150°C for AS5172B;

VDD = 4V – 12V (sync pulse voltage not included);

Magnetic Characterization; unless otherwise noted

Figure 9:
Electrical System Characteristics

Symbol	Parameter	Conditions	Min	Typ	Max	Unit
CRES	Core Resolution			14		bit
OutputRes		≥ 90° slope			12	bit
INLopt	Integral Non-Linearity (optimum)	Best aligned reference magnet ⁽¹⁾ at 25°C over full turn 360°	-0.5		0.5	deg
INLtemp	Integral Non-Linearity (optimum)	Best aligned reference magnet ⁽¹⁾ over temperature -40°C to 150°C over full turn 360°	-0.9		0.9	deg
INL	Integral Non-Linearity	Reference magnet ⁽¹⁾ over temperature -40°C to 150°C over full turn 360° and displacement	-1.4		1.4	deg
ST	Sampling Time			128		μs
SPDF	System Propagation Delay Fast	Depending on the PSI5 standard	200		500	Us
CoreClk	Core Clock			16		MHz
Coreclk tol	Tolerance of the Core Clock		-3.5		3.5	%
ON	Output Noise Peak to Peak	Related to 12-bit Not tested			4	LSB

Note(s):

1. Reference magnet: NdFeB, 8mm diameter, 2.5mm thickness.

Figure 10:
Power Management – Supply Monitor - Timing

Symbol	Parameter	Conditions	Min	Typ	Max	Unit
VDDUVTH	VDD Undervoltage Upper Threshold		3.6	3.8	4.0	V
VDDUVTL	VDD Undervoltage Lower Threshold		3.4	3.6	3.8	V
VDDUH	VDD Undervoltage Hysteresis	Info parameter	150	200	250	mV
UVDT	VDD Undervoltage Detection Time		10	50	250	μs
UVRT	Undervoltage Recovery Time		10	50	250	μs
VDDOVTH	VDD Overvoltage Upper Threshold	If sensor in overvoltage condition, ECU gets the Error flag. --> overheating possible in the application	16.7	18	19.1	V
VDDOVTL	VDD Overvoltage Lower Threshold		14.5	15.5	16.5	V
OVDT	VDD Overvoltage Detection Time	From the time VDD exceeding 16.5V		1000	2000	μs
OVRT	VDD Overvoltage Recovery Time	From the time VDD returning from VDD > 16.5V to normal operating voltage (4V < VDD < 17V)		1000	2000	μs
VDD3V3UVTH	VDD3V3 Reset Upper Threshold		2.5	2.8	2.95	V
VDD3V3UVTL	VDD3V3 Reset Lower Threshold		2.4	2.6	2.72	V
VDD3V3UVHYS	VDD3V3 Reset Hysteresis	Info parameter	105	175	245	mV
TDETWD	WatchDog Error Detection Time				12	ms

Magnetic Characteristics

T_{AMB}= -40°C to 125°C for AS5172A;

T_{AMB}=-40°C to 150°C for AS5172B;

VDD= 4V – 12V (sync pulse voltage not included); unless otherwise noted.

Two-pole cylindrical diametrically magnetized source:

Figure 11:
Magnetic Characteristics

Symbol	Parameter	Conditions	Min	Typ	Max	Unit
Bz	Orthogonal Magnetic Field Strength	Required orthogonal component of the magnetic field strength measured at the package surface along a circle of 1.25 mm @= 0	30		70	mT
BzE	Orthogonal Magnetic Field Strength –Extended Mode	Required orthogonal component of the magnetic field strength measured at the package surface along a circle of 1.25mm MFER = 1	10		90	mT
Disp ⁽¹⁾	Displacement Radius	Offset between defined device center and magnet axis. Dependent on the selected magnet.		0.5		mm

Note(s):

1. Reference magnet: NdFeB, 8mm diameter, 2.5mm thickness.

Electrical and Timing Characterization of the PS15 Interface

This chapter describes the synchronization signal from the ECU according to the PS15 specification V1.3 and V2.1. The parameters in this chapter are not reflecting the full specification range of the detection circuit for the synchronization signal.

Synchronization Signal PS15 V1.3

Figure 12:
Synchronization Signal

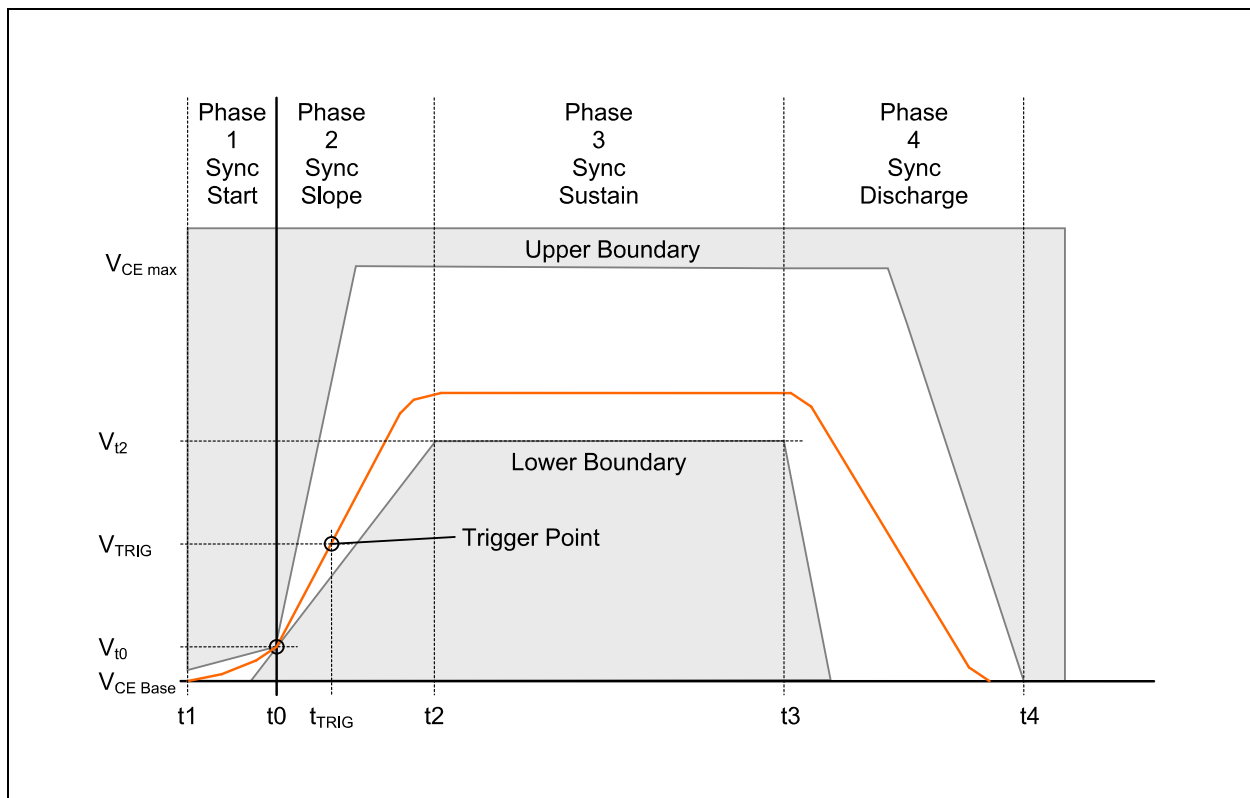

The synchronization signal start time t_0 is defined as a crossing of the V_{t0} value. In the “Sync Start” phase before this point, a “rounding in” of the voltage starting from $V_{CE, Base}$ to V_{t0} is allowed for a maximum of t_1 . During the “Sync Slope” phase, the voltage rises within given slew rates to a value between the minimum sync signal voltage V_{t2} and the maximum interface voltage $V_{CE, max}$. After maintaining the voltage between this limits until a minimum of t_3 , the voltage decreases in the “Sync Discharge” phase until having reached the initial $V_{CE, base}$ value until latest t_4 .

Figure 13:
Synchronization Signal PS15 V1.3 ⁽¹⁾

Symbol	Parameter	Conditions	Min	Typ	Max	Unit
VBase	Base Supply Voltage	Voltage value at ECU	5.7		11	V
Vto	Sync Slope Reference Voltage	Reference to VBase		0.5		V
Vt2	Sync Signal Sustain Voltage	Reference to VBase	3.5			V
Vce,max	Maximum Interface Voltage				16.5	V
t0	Reference Time	Reference time base; time when the sync signal crosses Vt0		0		μs
t1	Sync Signal Earliest Start	V=VCE Delta current less than 2mA	-3		0	μs
t2	Sync Signal Sustain Start	@ Vt2		7		μs
	Sync Slope Rising Slew Rate	Lower limit is valid for Vt0 to Vt2	0.43	1.0	1.5	V/μs
	Sync Slope Falling Slew Rate		-1.5			V/μs
t3	Sync Signal Sustain Time			16		μs
t4	Discharge Time Limit			35		μs
Tslot1	Start of Time Slot 1		44	51	59	μs
Tslot2	Start of Time Slot 2		181.3	195	210	μs
Tslot3	Start of Time Slot 3		328.9	350	373	μs

Note(s):

1. The parameters in this table are just info parameters and therefore not production tested. The production related parameters are in the [PS15 Block Parameters](#) table.

Figure 14:
Synchronization Signal PSIS V2.1 ⁽¹⁾

Symbol	Parameter	Conditions	Min	Typ	Max	Unit
VBase	Base Supply Voltage	Voltage value at ECU	5.7 (4.4)		11	V
Vto	Sync Slope Reference Voltage	Reference to VBase		0.5		V
Vt2	Sync Signal Sustain Voltage	Reference to VBase	3.5 (2.5)			V
Vce,max	Maximum Interface Voltage				16.5	V
t0	Reference Time	Reference time base; time when they sync signal crosses Vt0		0		μs
t1	Sync Signal Earliest Start	V=V _{CE} Delta current less than 2mA	-3		0	μs
t2	Sync Signal Sustain Start	@ Vt2		7		μs
	Sync Slope Rising Slew Rate	Lower limit is valid for Vt0 to Vt2	0.43		1.5	V/μs
	Sync Slope Falling Slew Rate		-1.5			V/μs
t3	Sync Signal Sustain Time			16		μs
t4	Discharge Time Limit				35	μs
Tslot1	Start of Time Slot 1		44			μs

Note(s):

1. The parameters in this table are just info parameters and therefore not production tested. The production related parameters are in the [PSIS Block Parameters](#) table.

Synchronization Signal Detection

The AS5172 has to detect the trigger within the “trigger window” during the rising slope of the synchronization signal at the trigger point with the trigger voltage V_{TRIG} and the trigger time t_{TRIG} .

Figure 15:
Trigger Window

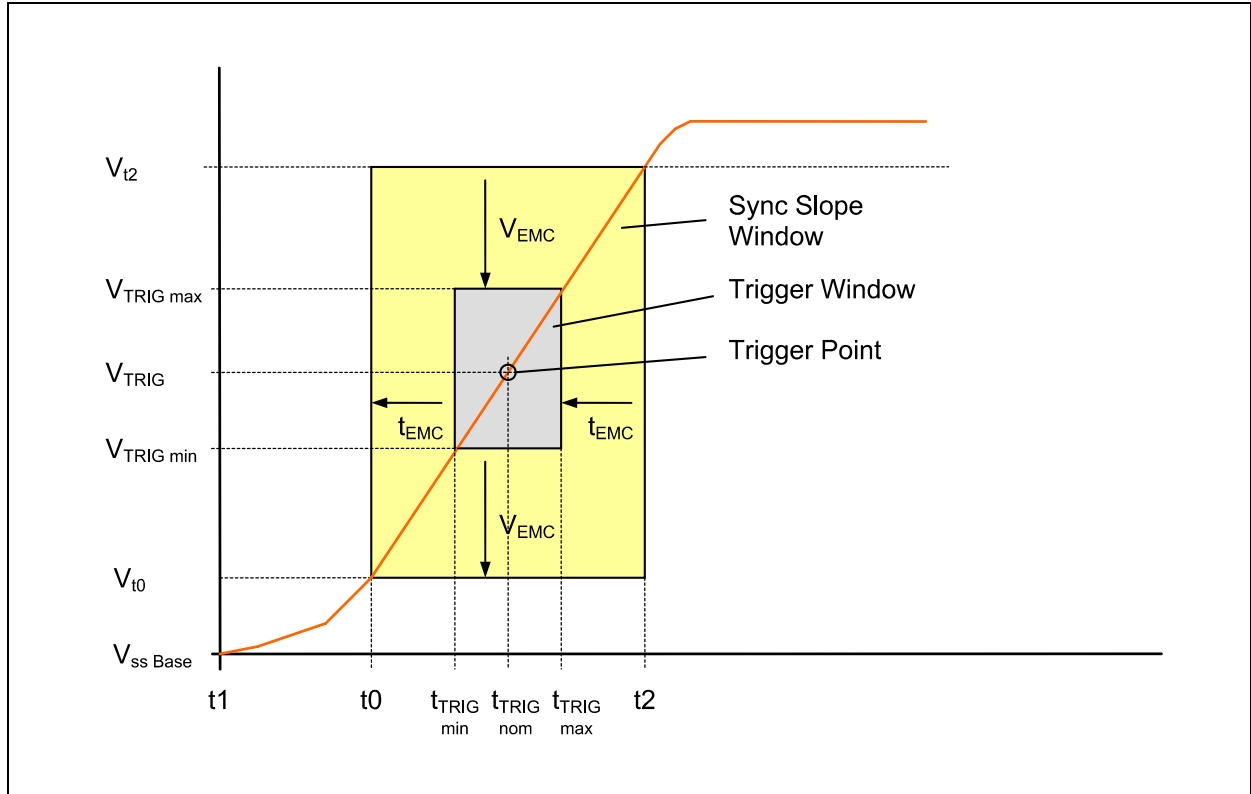

In order to take into account voltage differences at different points of the interface lines, an additional safety margin for the trigger detection is defined by V_{EMC} and t_{EMC} .

The values are based on the PS15 specification and shows the detection of the synchronization signal from the ECU according the PS15 specification.

Figure 16:
Synchronization Detection ⁽¹⁾

Symbol	Parameter	Conditions	Min	Typ	Max	Unit
VEMC_C	Margin for Voltage Variations	Common power mode	-0.9		0.9	V
VEMC_LP	Margin for Voltage Variations	Low power mode	-0.7		0.7	V
VTrig_C	Trigger Voltage Threshold	Common power mode	1.4	2.0	2.6	V
VTrig_LP	Trigger Voltage Threshold	Low power mode	1.2	1.5	1.8	V
tTRIG	Nominal Trigger Detection Time	@ V _{TRIG} , @ AS5172 Pins; Referenced to a straight sync signal slope with nominal slew rate of 0.43 V/ μ s	2.1	3.5	4.9	μ s
VCE,max	Maximum Interface Voltage				16.5	V
tEMC	Margin for Timing Variations of the Signal on the Interface Line	Relative to nominal trigger window time	-2.1		2.1	μ s
ttol detect	Tolerance of Internal Trigger Detection Delay				3	μ s
TTRIG	Trigger Detection Time	$T_{TRIG} = t_{TRIG} + t_{tol\ detect} + t_{EMC}$; Reference for AS5172 time base	0		10	μ s

Note(s):

1. The parameters in this table are just info parameters and therefore not production tested. The production related parameters are in the [PSI5 Block Parameters](#) table.

Synchronization Signal with Discharge by AS5172

This chapter describes the modifications required if the ECU uses a special transceiver.

The parameters in this chapter are not reflecting the full specification range of the detection circuit for the synchronization signal.

Figure 17:
Synchronization Signal from ECU with Discharge by the AS5172

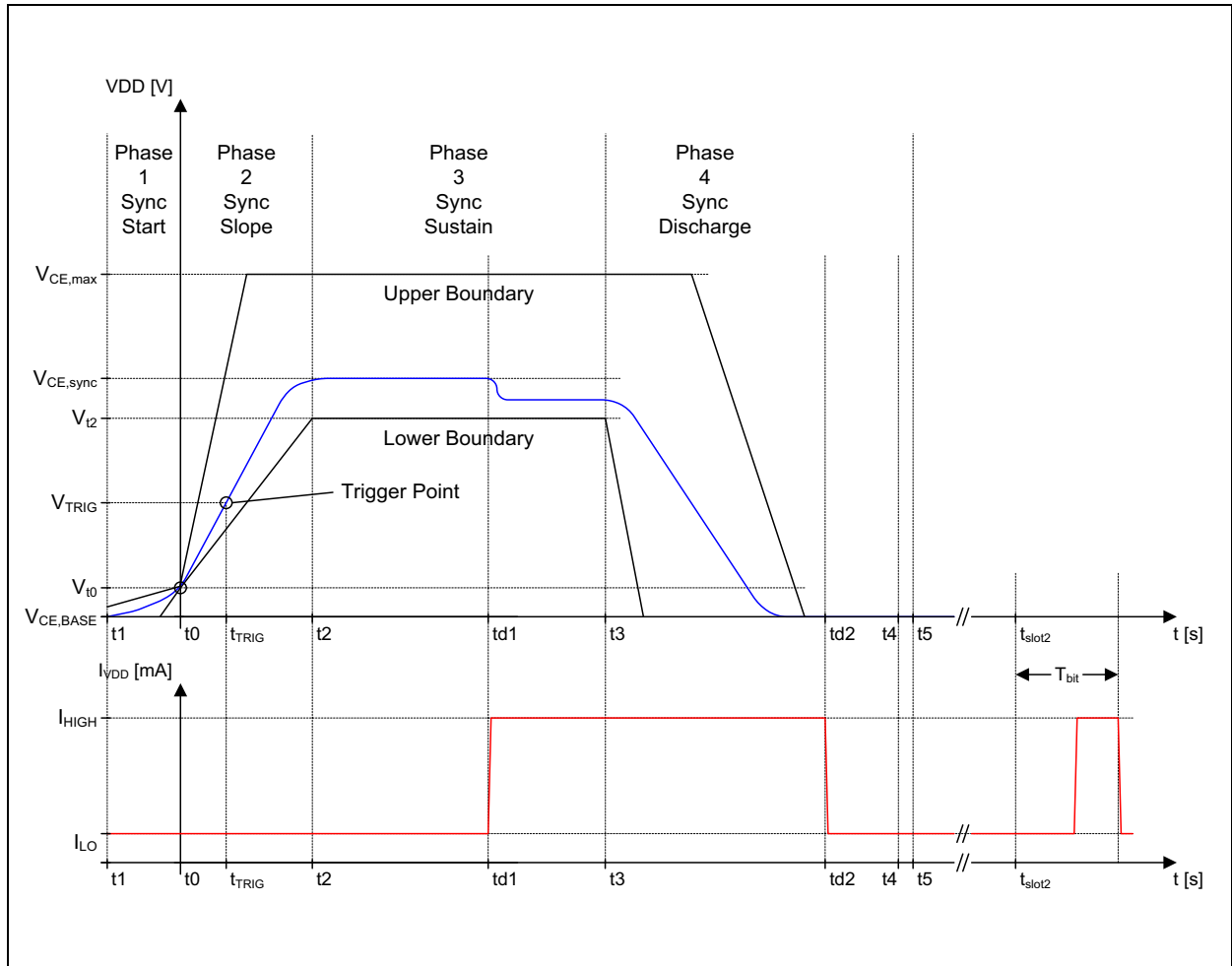

Figure 18:
Synchronization Signal from ECU with Discharge Parameter ⁽¹⁾

Symbol	Parameter	Conditions	Min	Typ	Max	Unit
$V_{CE,BASE}$	Base Supply Voltage	Mean voltage value at ECU	5.0	6.0	7.0	V
$V_{CE,BASE_R}$	Base Supply Voltage Including Ripple		4.5	6.0	7.0	V
V_{t0}	Sync Slope Reference Voltage	Referenced to $V_{CE,BASE}$		0.5		V
V_{t2}	Sync Signal Sustain Voltage	Referenced to $V_{CE,BASE}$	+3.5	+5.0	+6.0	V
$V_{CE,max}$	Sync Signal Max. Voltage		10	11	14.5	V
V_{CE,max_R}	Sync Signal Max. Voltage Including Ripple		10	14	16.5	V
t_0	Reference Time	Reference time base; time when the synchronization signal crosses V_{t0}		0		μs
t_1	Sync Signal Earliest Start	$V=V_{CE,BASE}$	-3		0	μs
t_2	Sync Signal Sustain Start	@ V_{t2}	3	4	5	μs
$S_{sync,r}$	Sync Slope Rising Slew Rate	10% to 90% of $V_{CE,max}$	0.7	1.0	1.6	V/ μs
$S_{sync,f}$	Sync Slope Falling Slew Rate	90% down to 10% of $V_{CE,max}$	-1.6	-1.0	-0.7	V/ μs
t_3	Sync Signal Sustain Time	$V=V_{CE,sync}$	27.5	31	35.1	μs
td_1	AS5172 Signals Discharge		18.5	22.75	28	μs
td_2	Discharge Stop Time		38	43.25	50	μs
t_4	Enable Pull Down to $V_{CE,BASE}$ by ECU		62.5	65	65.5	μs
t_5	Receiver (ECU) Enable Start Time	Receiver (ECU) read for transmission	63	66.2	65.5	μs
V_{TRIG}	Trigger Voltage Threshold		1.4	2.0	2.6	V
t_{TRIG}	Nominal Trigger Detection Time	@ V_{TRIG} , @ AS5172 Pins; Referenced to a straight sync signal slope with nominal slew rate of 0.7 V/ μs	1.25	2.15	3.05	μs
t_{EMC}	Margin for Timing Variations of the Signal on the Interface Line	Relative to nominal trigger window time	-1.25		1.25	μs

Symbol	Parameter	Conditions	Min	Typ	Max	Unit
$t_{\text{tol detect}}$	Tolerance of Internal Trigger Detection Delay				3	μs
T_{TRIG}	Trigger Detection Time	$T_{\text{TRIG}} = t_{\text{TRIG}} + t_{\text{tol detect}} + t_{\text{EMC}}$ Reference for sensor time base	0		7.5	μs
$t_{\text{slot 1}}$	Start of Time Slot 1	Time slot 1 cannot be used in this communication mode	44	51	59	μs
$t_{\text{slot 2}}$	Start of Time Slot 2		181.3	195	210	μs
$t_{\text{slot 3}}$	Start of Time Slot 3		328.9	350	373	μs

Note(s):

- The parameters in this table are just info parameters and therefore not production tested. The production related parameters are in the [PSI5 Block Parameters](#) table.

PSI5 Block Parameters

Figure 19:
Block Parameters

Symbol	Parameter	Conditions	Min	Typ	Max	Unit
$V_{CE,BASE\ ECU}$	Base ECU Supply Voltage	Voltage at ECU	4.4		11	V
$V_{CE,BASE}$	Base Supply Voltage	Voltage at the Sensor	4.0		11	V
V_{SUPPLY}	Low Supply Voltage	Supply voltage for comparator	3.3	3.45	3.6	V
V_{t0}	Sync Slope Reference	Referred to $V_{CE,BASE}$		0.5		V
V_{t2}	Minimum Sync Signal Sustain Voltage (common mode)	Referred to $V_{CE,BASE}$	3.5			V
V_{t2_L}	Minimum Sync Signal Sustain Voltage (low power mode)	Referred to $V_{CE,BASE}$	2.5			V
$V_{CE\ MAX}$	Maximum Interface Voltage				16.5	V
t_2	Sync Signal Sustain Start	Voltage @ V_{t2}			7	μs
SL_{RISE}	Rising Slope		0.43		1.6	V/ μs
SL_{FALL}	Falling Slope	Depends on voltage and discharge limit, external load has to meet these values	-1.75			V/ μs
t_3	Sync Signal Sustain Time	Info parameter: Recommended ECU timing	16		35.1	μs
t_4	Discharge Time Limit	Info parameter: Allowed variation of synch pulse width for synch pulse detection circuit	17.67		62	μs
T_{SYNC}	Synchronization Period	Info parameter: To prevent shifts of detection threshold	250	500		μs
V_{TRIG}	Trigger Voltage Threshold (common mode)		1.4	2.0	2.6	V
V_{TRIG_L}	Trigger Voltage Threshold (low power mode)		1.2	1.5	1.8	V

Symbol	Parameter	Conditions	Min	Typ	Max	Unit
$V_{TRIG\ EMC}$	Trigger Voltage Threshold Under EMC (common mode)	At $SL_{RISE} = 0.43\ V/\mu s$; For EMC $\leq 1V_{PEAK}$ $\geq 100kHz$ Not tested - Guaranteed by Design	0.5	2.0	3.5	V
$V_{TRIG\ EMC}$	Trigger Voltage Threshold Under EMC (low power mode)	At $SL_{RISE} = 0.43\ V/\mu s$; For EMC $\leq 1V_{PEAK}$ $\geq 100kHz$ Not tested - Guaranteed by Design	0.5	1.5	2.5	V
$t_{tol\ detect}$	Tolerance of Internal Trigger Detection Delay				3	μs
t_{BLANK}	Output Signal Blanking Time	Blanking of trigger signal in digital part after first rising edge to avoid multiple trigger signals during EMC events. Not tested - Guaranteed by Design	121		135	μs
V_{COM}	Comparator Input Common Mode Voltage			1.5		V
RES_{div}	Resistor Divider Division Factor	Not tested - Guaranteed by Design 2% mismatch	7.84	8	8.16	V/V
f_{C_LP}	Low Pass Filter Cut-Off Frequency	Not tested - Guaranteed by Design	2.5	5	7.5	kHz

Detailed Description

The AS5172 is a Hall-based rotary magnetic position sensor using a CMOS technology. The lateral Hall sensor array converts the magnetic field component perpendicular to the surface of the chip into a voltage.

The signals coming from the Hall sensors are first amplified and filtered before being converted by the analog-to-digital converter (ADC). The output of the ADC is processed by the CORDIC block (Coordinate-Rotation Digital Computer) to compute the angle and magnitude of the magnetic field vector. The sensor and analog front-end (AFE) section works in a closed loop alongside an AGC to compensate for temperature and magnetic field variations. The calculated magnetic field strength (MAG), the automatic gain control (AGC) and the angle can be read through the UART-over-PSI5 protocol during programming.

The magnetic field coordinates provided by the CORDIC block are fed into a linearization block (DSP) which generates the transfer function.

The output of the AS5172 can be programmed to define a starting position (zero angle) and a stop position (maximum angle).

The AS5172 can be programmed through the VDD Pin with a special UART-over-PSI5 protocol which allows writing an on-chip non-volatile memory (One Time Programmable memory) where the specific settings are stored.

The AS5172 is equipped with a PSI5 Interface current driver and a PSI5 Interface receiver. The current driver drives the additional sink current to reach the I_{high} level on the VDD. The receiver is comparing the voltage level at the VDD Pin with the internal voltage thresholds.

The Sensor to ECU communication is described in the chapters below and is based upon the PSI5 standard.

The AS5172 supports, according the PSI5 standard, the synchronous mode or in asynchronous mode.

In PSI5 V1.3 (10-bit mode), the asynchronous modes can only use one time slot per period. For a transmission of one 12/16 bit data word, two periods are necessary.

AS5172 supports the bus modes PSI5-U and PSI5-P. The daisy chain mode is not supported.

Register Description

OTP (non-volatile memory) Register Description

Figure 20:
OTP (non-volatile memory) Register Description

Address	Bit Nr.	Symbol	Description
0x01	0	Factory settings	ams factory settings
	1		
	2	Direction	Changes direction in 14-bit mode
	3	PSI5_14bit_angle	Enables 14-bit angle output
	4	PSI5_quad_info	Enables quadrant information
	5	PSI5_16bit_frame	Enables the PSI5 16-bit frame
	6	Velocity_extended_range	0 = 1250 deg/s 1 = 5000 deg/s
	7	Extended_init_phase	0 = 22 datablocks during Init phase 1 = 32 datablocks during Init phase
0x02	0	Factory settings	ams factory settings
	7:1	ams ID	ams ID (F9)
0x03	7:0	ams ID	ams ID (F9)
0x04	5:0	ams ID	ams ID (F9)
	7:6	Factory settings	ams factory settings
0x05	7:0	Factory settings	ams factory settings
0x06	7:0		
0x07	7:0		
0x08	7:0		
0x09	7:0		
0x0A	7:0		
0x0B	7:0		

Address	Bit Nr.	Symbol	Description
0x0C	0	Month[3]	Sensor Production Date (F8)
	1	Year[0]	
	2	Year[1]	
	3	Year[2]	
	4	Year[3]	
	5	Year[4]	
	6	Year[5]	
	7	Year[6]	
0x0D	0	Day[0]	Sensor Production Date (F8)
	1	Day[1]	
	2	Day[2]	
	3	Day[3]	
	4	Day[4]	
	5	Month[0]	
	6	Month[1]	
	7	Month[2]	
0x0E	0	Type[0]	Sensor Type (F4)
	1	Type[1]	
	2	Type[2]	
	3	Type[3]	
	4	Parameter[4]	Sensor Parameter (F5)
	5	Parameter[5]	
	6	Parameter[6]	
	7	Parameter[7]	

Address	Bit Nr.	Symbol	Description	
0x0F	0	Parameter[0]	Sensor Parameter (F5)	
	1	Parameter[1]		
	2	Parameter[2]		
	3	Parameter[3]		
	0x0F	4	Sensor_Code_Man[4]	Sensor Code Manufacturer (F6)
		5	Sensor_Code_Man[5]	
		6	Sensor_Code_Man[6]	
		7	Sensor_Code_Man[7]	
0x10	0	Sensor_Code_Man[0]	Sensor Code Manufacturer (F6)	
	1	Sensor_Code_Man[1]		
	2	Sensor_Code_Man[2]		
	3	Sensor_Code_Man[3]		
	0x10	4	Sensor_Code_Veh[3]	Sensor Code Vehicle (F7)
		5	Sensor_Code_Veh[3]	
		6	Sensor_Code_Veh[3]	
		7	Sensor_Code_Veh[3]	
0x11	7:0	PSI5Mode	PSI5 mode selection	
0x12	0	Sync_discharge	Enables sync pulse discharging	
	1	Init_phase_repetition[0]	PSI5 initialization phase repetition factor (k-times)	
	2	Init_phase_repetition[1]		
	3	PSI5_timeslot[0]	PSI5 timeslot for bus mode	
	4	PSI5_timeslot[1]		
	5	Init_phase_disable	Disables the PSI5 initialization phase	
	6	Velocity_info	Enables PSI5 velocity output	
	7	-	Not used	

Address	Bit Nr.	Symbol	Description
0x13	0	-	Not used
	1	-	Not used
	2	-	Not used
	3	Quadrant[0]	Quadrant selection
	4	Quadrant[1]	
	5	Velocity_filter[0]	Filter configuration for velocity measurement
	6	Velocity_filter[1]	
	7	Velocity_filter[2]	
0x14	7:0	CLH[7:0]	Clamping level high
0x15	0	CLH[8]	Clamping level high
	1	CLH[9]	
	2	CLH[10]	
	3	CLH[11]	
	4	CLL[0]	Clamping level low
	5	CLL[1]	
	6	CLL[2]	
	7	CLL[3]	
0x16	7:0	CLL[11:4]	Clamping level low
0x17	7:0	Offset[7:0]	Offset
0x18	7:0	Offset[15:8]	Offset
0x19	0	Offset[16]	Offset
	1	Offset[17]	
	2	Offset[18]	
	3	Offset[19]	
	4	Gain[0]	Gain
	5	Gain[1]	
	6	Gain[2]	
	7	Gain[3]	
0x1A	7:0	Gain[11:4]	Gain

Address	Bit Nr.	Symbol	Description
0x1B	0	Gain[12]	Gain
	1	Gain[13]	
	2	Gain[14]	
	3	Gain[15]	
	4	Gain[16]	
	5	BP[0]	Breakpoint / 14-Bit Mode zero offset
	6	BP[1]	
	7	BP[2]	
0x1C	7:0	BP[10:3]	Breakpoint / 14-Bit Mode zero offset
0x1D	0	BP[11]	Breakpoint / 14-Bit Mode zero point offset
	1	BP[12]	
	2	BP[13]	
	3	Extended_range_disable	Disables the extended range for magnetic input field
	4	Reduced_angle_range	Enables the reduced angle range for segments smaller 23 degree
	5	-	Not used
	6	-	Not used
	7	Customer_lock	Customer lock
0x1E	7:0	VendorID[7:0]	Vendor ID (F3)
0x1F	7:0	Signature[7:0]	Signature calculated across the full OTP

Volatile Memory Register Description

Figure 21:
Volatile Memory Register Description

Address	Bit Nr.	Symbol	R/W	Description
0x23	4:0	-		Not used
	5	DSP_reset	R/W	Reset of the DSP (Digital Signal Processing)
	6	GLoad	R/W	Enables GLoad
	7	-		Not used
0x32	7:0	Angle_CORDIC[7:0]	R	14-Bit Angle information (raw value without zero offset)
0x33	5:0	Angle_CORDIC[13:8]	R	
	7:6	-		Not used
0x34	7:0	Magnitude	R	Magnitude at the CORDIC output
0x35	7:0	AGC	R	AGC (Automatic Gain Control)
0x36	7:0	Angle_DSP[7:0]	R	12-Bit Angle information (with zero offset, and customer settings)
0x37	3:0	Angle_DSP[11:8]	R	
	7:4	-		Not used
0x38	7:0	Velocity[7:0]	R	Velocity output
0x39	3:0	Velocity[11:8]	R	
	7:4	-		Not used
0x3A	7:0	FUSA[7:0]	R	FUSA output
0x3B	5:0	FUSA[13:8]	R	

SFR Description

Figure 22:
SFR Description

Address	Bit Nr.	Symbol	Description
0x60	7:0	Pass2Function	Pass-to-function, see Programming chapter
0x61	7:0		
0x62	7:0	BurnOTP	BurnOTP, see Programming chapter
0x63	7:0		

Programming

UART-Over-PSIS

The AS5172 is equipped with a one wire UART-over-PSIS interface based on a “Tooth Gap” similar method according PSIS specification, which allows reading and writing the registers as well as permanent programming of the non-volatile OTP memory (One Time Programmable).

By default the AS5172 is in the so-called *Communication Mode*. In this mode, it is possible to configure the register settings.

A voltage modulation on the supply lines (VDD and GND) is used to realize a Programmer-to-Sensor communication. The Sensor-to-Programmer communication is done with current modulation.

The physical layer of the two communication modes is shown in [Figure 23](#) and [Figure 24](#) below.

Figure 23:
Bit Encoding of Programmer-to-Sensor Communication

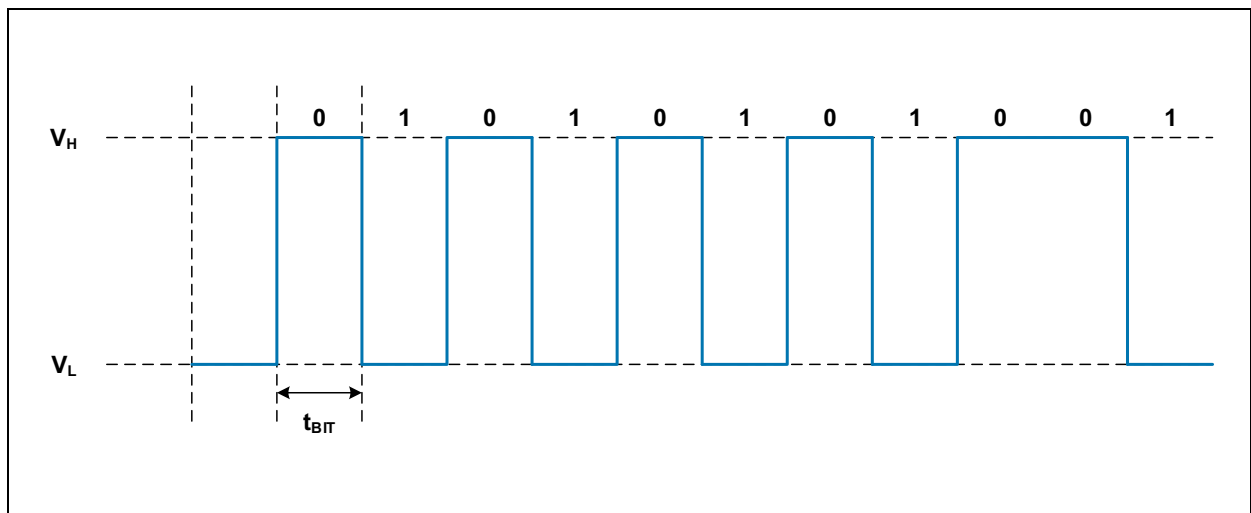

A logical “0” is represented by a sync pulse (V_H) on the VDD line for a duration of t_{BIT} . A logical “1” by the absence of the sync pulse (V_L) for a duration of t_{BIT} .

Figure 24:
Bit Encoding of Sensor-to-Programmer Communication

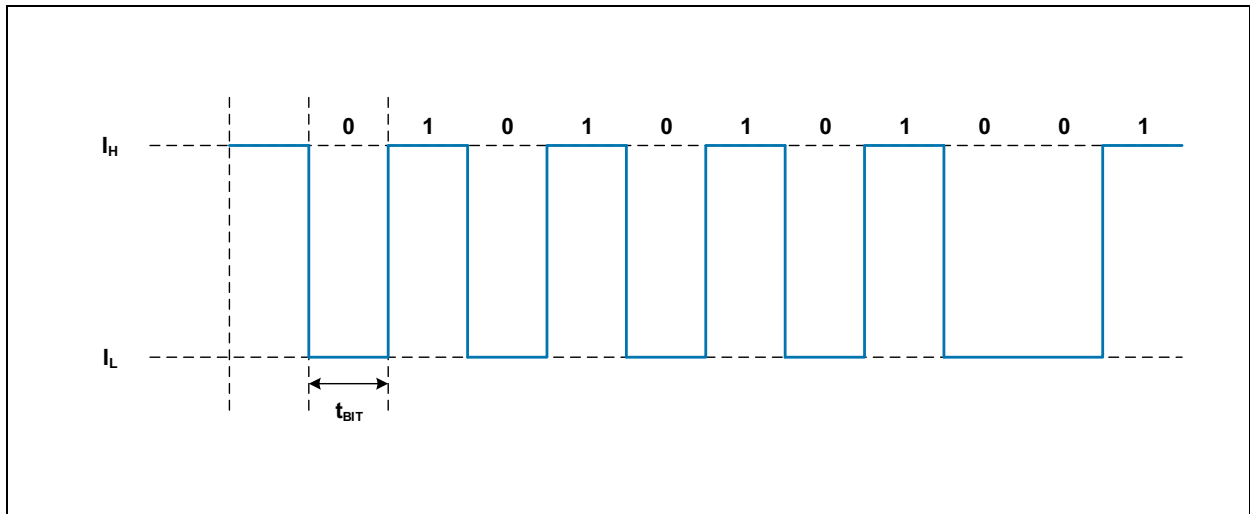

A logical “0” is represented by an increased sink current (I_H) on the VDD line for a duration of t_{BIT} . A logical “1” by normal sink current (I_L) for a duration of t_{BIT} .

Figure 25:
UART-Over-PSIS Protocol

Symbol	Parameter	Conditions	Min	Typ	Max	Unit
V_H	High Level Voltage		11		12	V
V_L	Low Level Voltage		5.5		6	V
I_H	High Level Sink Current	Typical value		49		mA
I_L	Low Level Sink Current	Typical value		19		mA
t_{BIT}			25.6	26	26.5	μ s
Baudrate			37800	38400	39000	Baud

For further information please refer to application note *AN_AS5172_Programming_Procedure_V1-00*

ams also provides a programmer which supports the above-mentioned protocol. Please get in contact with the application engineering team.

UART Protocol

The UART interface allows reading and writing two consecutive addresses. The standard UART sequence consists of four frames. Each frame begins with a start bit (START), which is followed by 8 data bits (D[0:7]), one parity bit (PAR), and a stop bit (STOP), as shown in Figure 26.

Figure 26:
UART Protocol Frame

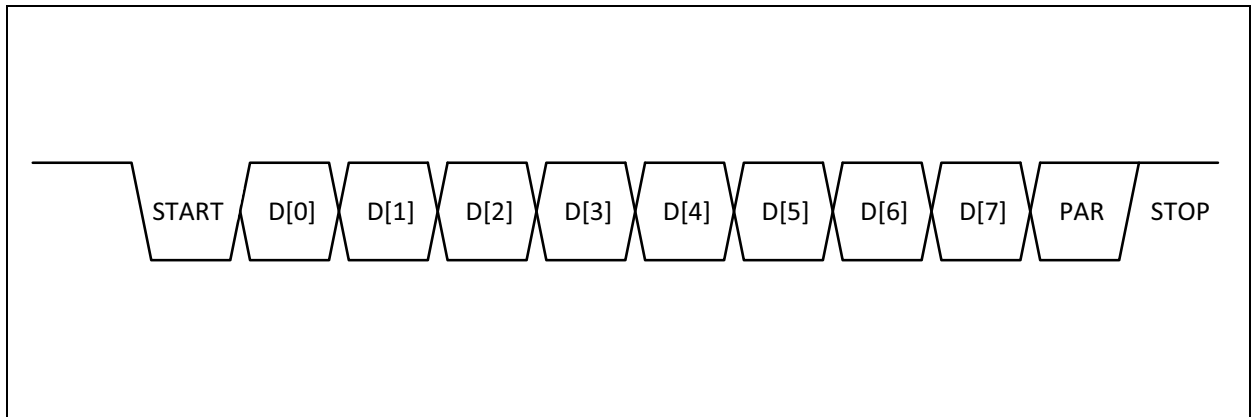

The PAR bit is even parity calculated over the data bits (D[7:0]). Each frame is transferred from LSB to MSB.

The first frame is the synchronization frame and consists D[7:0] = 0x55. This frame synchronizes the baud rate between the AS5172 and the programmer.

The second frame contains the register address (D[6:0] = ADDRESS) and the write/read command (WRITE: D[7]=0; READ: D[7]=1).

The third and fourth frame will be written/read to/from the location specified by ADDRESS and ADDRESS+1, respectively. Figure 27 and Figure 28 show examples of a WRITE and READ sequence.

Figure 27:
Example of WRITE (Reg[0x23] = 0x20 and Reg [0x24] = 0x00)

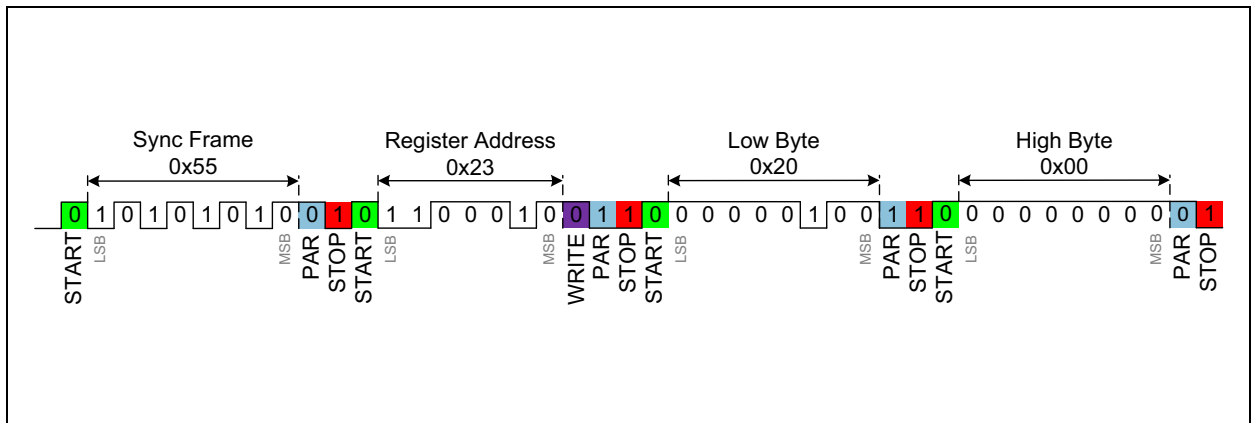
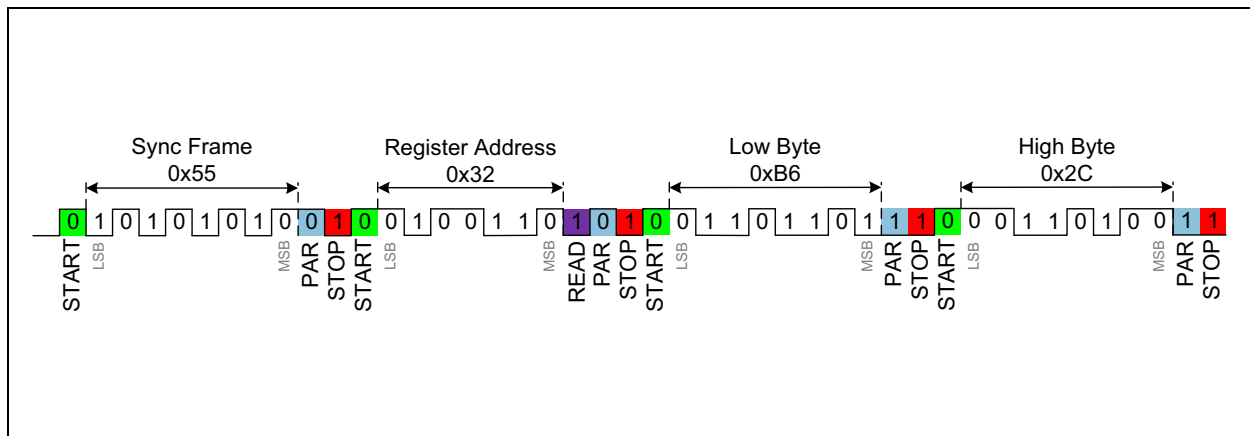

Figure 28:
Example of READ (Reg[0x32] = 0xB6 and Reg [0x24] = 0x2C)



Reading of the 14-Bit Angle Information

To read the current position of the magnet (Angle) the following procedure is necessary:

1. Set the DSP_reset bit in Reg(0x23) to 1. (WRITE Reg(0x23) = 0x20)
2. Read Angle_CORDIC register (READ Reg(0x32) and Reg(0x33))
3. Set the DSP_reset bit in Reg(0x23) to 0. (WRITE Reg(0x23) = 0x00)

The DSP_reset bit resets the internal DSP. After a reset, the Angle_CORDIC register is updated.

Reading the Magnitude and AGC

To read the current Magnitude and AGC value following procedure is necessary:

1. Set the DSP_reset bit in Reg(0x23) to 1. (WRITE Reg(0x23) = 0x20)
2. Read Magnitude and AGC register (READ Reg(0x34) and Reg(0x35))
3. Set the DSP_reset bit in Reg(0x23) to 0. (WRITE Reg(0x23) = 0x00)

The DSP_reset bit resets the internal DSP. After a reset, the Magnitude and AGC registers are updated.

Exiting the Communication Mode

To exit the *Communication Mode* and enter *Functional Mode* a special Pass-to-function command is necessary. Therefore a specific value has to be written into registers 0x60 and 0x61.

Pass2Function: WRITE Reg(0x60) = 0x70 and Reg(0x61) = 0x51

The device is temporarily set to operational mode until a sensor reset happens.

Burn the OTP Registers

To permanently program the device a special BurnOTP command is necessary. Therefore a specific value has to be written into registers 0x62 and 0x63.

BurnOTP: WRITE Reg(0x62) = 0x70 and Reg(0x63) = 0x51

This commands permanently burns the OTP memory based on poly silicon fuses. After fusing a verification of the burn quality is mandatory to avoid bit-flips over temperature and lifetime. This can be done with the GLoad operation. For further information please refer to application note [AN_AS5172_Programming_Procedure_V1-00](#).

AS5172 Transfer Function

After programming the Customer_lock in the OTP or by using the Pass-to-function command the AS5172 is working in the selected PS15 mode over the VDD pin.

The DSP block generates a linear transfer function proportional to the angle of the rotating magnet which is fed into the PS15 interface. The PS15 interface works with 10-bit resolution in PS15 V1.3 and 12-bit resolution in PS15 V2.1. [Figure 29](#) shows the transfer function in detail.

Figure 29:
Transfer Function

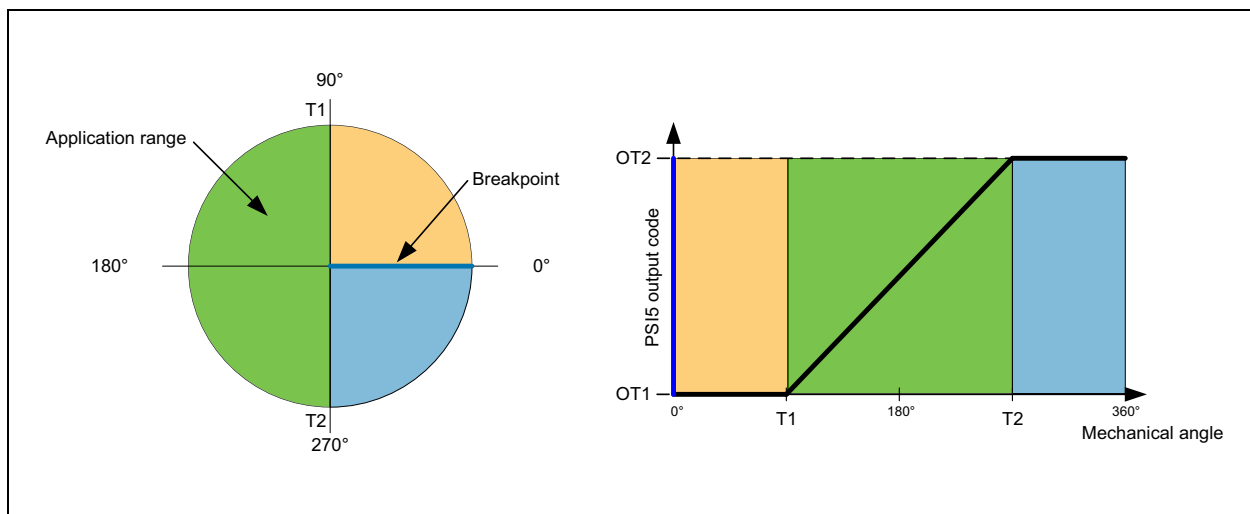

Figure 30:
PSI5 Protocol Output Resolution

Symbol	Parameter	Conditions	Value	Unit
OTR_V1.3	Output Resolution PSI5 V1.3	PSI5 V1.3	10	Bit
OT1			-480	LSB
OT2			+480	LSB
OTR_V2.1	Output Resolution PSI5 V2.1	PSI5 V2.1	12	Bit
OT1			-2048	LSB
OT2			+2048	LSB

The PSI5 output characteristic is programmable in the OTP memory. The parameters T1, T2 and BP define the linear transfer function. [Figure 29](#) shows a simple example of a typical output function.

The mechanical starting point T1 and the mechanical end point T2 define the mechanical range. The BP (Breakpoint) defines the transition point between OT1 and OT2.

These parameters are input parameters. Using a DLL provided by **ams**, these parameters are converted into the final OTP parameters: CLH, CLL, Offset, Gain and BP.

For detailed information regarding the calculation DLL please get in contact with the application engineering team at **ams**.

Multiple Quadrants

The multiple quadrant option allows repeating the same output slope up to four times over a full 360° rotation as shown in [Figure 32](#), [Figure 33](#), [Figure 34](#) and [Figure 35](#). The Quadrant bits in register (0x13) set the number of quadrant as shown in [Figure 31](#). Additionally a built-in quadrant detection can indicate the currently active quadrant in a special PSI5 data frame. For more information please refer to chapter [PSI5 Modes](#).

Figure 31:
Quadrant Selection

Quadrant	Number of Quadrants	Max. Mechanical Range
00	Single	360°
01	Dual	180°
10	Triple	120°
11	Quadruple	90°

Figure 32:
Single Quadrant

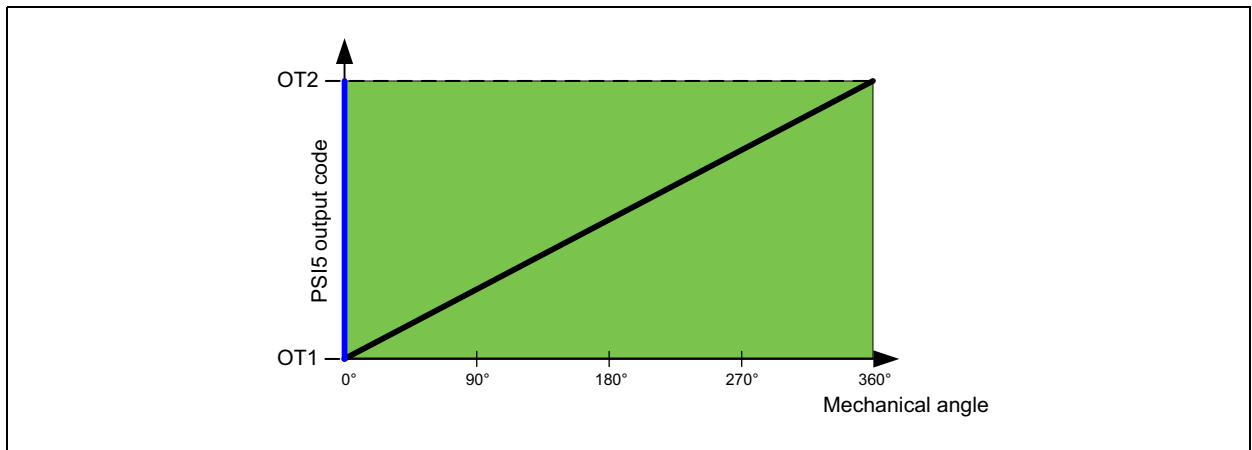

Figure 33:
Dual Quadrant

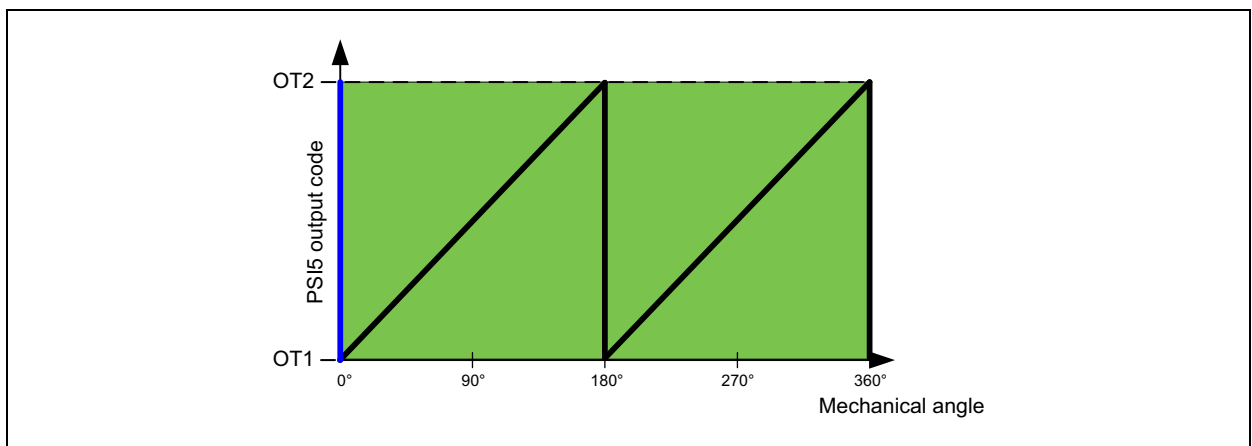

Figure 34:
Triple Quadrant

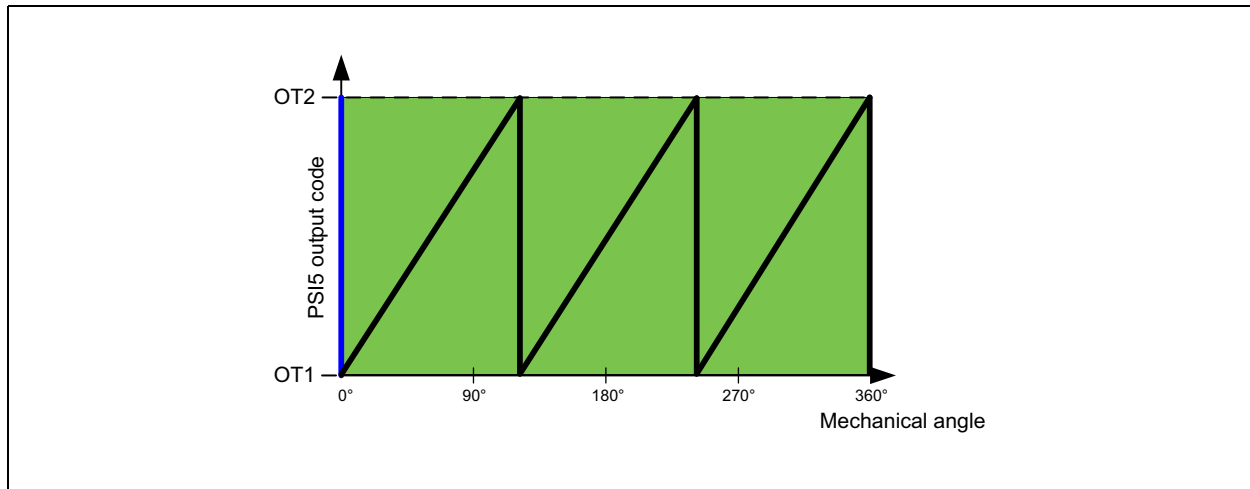
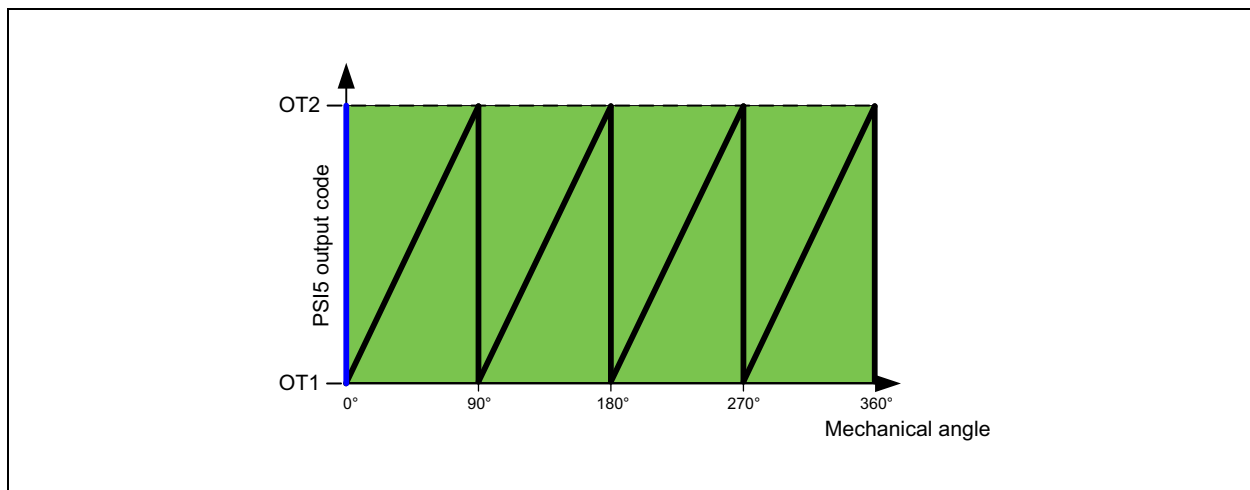

Figure 35:
Quadruple Quadrant



Extended Magnetic Input Range

By default the AS5172A and AS5172B operates in Extended Mode. This mode extends the magnetic input field range and allows increasing of the air gap between sensor and magnet. The extended range can be disabled with `Extended_range_disable` bit. For further information about the Extended Mode please refer to application note "AN_AS5172_ExtendedMode_V1-00.pdf".

Rolling Counter

The frame control bits in the PSI5 frame can be used as a rolling counter. This setting can be enabled in the OTP. If this setting is enabled the rolling counter starts incrementing from value 0x0 once the initialization is finished. When reaching a value of 0x7 the counter is reset at starts with 0x0 again.

In PSI5 16-bit frame mode, the rolling count enables a toggle bit in A14 of the frame.

Angular Velocity Measurement

The AS5172 features an average angular velocity calculation algorithm with 12-bit resolution. This angular velocity information can be used without further averaging in the ECU. The sensor calculates the velocity for each CORDIC cycle (typ. 128µs). Due to the PS15 interface limitation the information can only be send every 500µs.

To optimize the signal-to-noise performance the cut off frequency is programmable via `Velocity_filter[2:0]` bits in register 0x13. The velocity information is available in all P20CRC-500 and P16CRC-500 modes. Additionally the range of the velocity can be programmed by `Velocity_extended_range` bit in register 0x01.

Figure 36:
Angular Velocity Measurement Parameter

Symbol	Parameter	Min	Typ	Max	Unit	Comments
VRes	Velocity Signal Resolution		12		Bit	
VRange	Measurement Range (default)		1250	1374	°/s	Only typical value is guaranteed
VRangeE	Measurement Range (extended)		5000	5496	°/s	Only typical value is guaranteed
VSens	Velocity Sensitivity (default)		0.671		°/s/Bit	12-bit resolution
VSensE	Velocity Sensitivity (extended)		2.684		°/s/Bit	12-bit resolution, only in Extended Mode
FCutOff	Cut Off Frequency	19	77	260	Hz	Programmable with <code>Velocity_filter[2:0]</code>
VNoise	Velocity Noise	4.9		70.5	°/s	RMS noise depending on <code>Velocity_filter[2:0]</code>
VError	Velocity Total Error			±3.5	%	Clock frequency accuracy

Figure 37:
Angular Velocity Measurement Filter Parameters

Velocity_filter[2:0]	FCutOff [Hz]	VNoise [°/s]	VDelay [ms]	VStepResponse [ms]
000	260	70.5	0.61	0.9
001	152	37.3	1.05	1.8
010	77	19.2	2.07	3.7
011	39	9.7	4.08	6.7
100	19	4.9	8.38	13.9

Special Functions

The AS5172 features special functions which can be activated in the OTP. This settings are not according the PSi5 V2.1 standard.

14-Bit Mode

The 14-bit mode is only available for AS5172A and AS5172B. In this mode the 14-bit angle information is provided on the PSi5 interface. The 14-bit mode can be activated by PSi5_14bit_angle bit. (Quadrant setting must be 00)

This special setting works different to the typical AS5172 transfer function.

If this mode is activated, the sensor uses registers 0x1B to 0x1D as zero offset registers. Additionally the bit Direction in register 0x01 changes the direction of the output function.

Figure 38:
PSi5 Protocol Output Resolution

Symbol	Parameter	Conditions	Value	Unit
OTR_14	Output Resolution 14-Bit Mode	PSi5 V2.1	14	Bit
OT1			-8192	LSB
OT2			+8192	LSB

Quadrant Detection

The PSi5 protocol includes an information of the used quadrant. Detection necessary for safety relevant application to detect a movement from one quadrant to the next. See detailed [Protocol Information](#).

Extended PSi5 Initialization Phase

Extending to 32 datablock during Init phase. D1 to D22 according [Figure 67](#). D23 to D32 = 0000. Extension necessary for systems with 32 Datablocks during Init Phase.

PSI5 Interface

Bit Encoding - AS5172 to ECU Communication

A "low" level ($I_{S,Low}$) is represented by the normal (quiescent) current consumption of the Sensor(s). A "high" level ($I_{S,High}$) is generated by an increased current sink of the Sensor ($I_{S,Low} + \Delta I_S$). The current modulation is detected within the receiver Sensor.

Figure 39:
Bit Encoding Using Supply Current Modulation

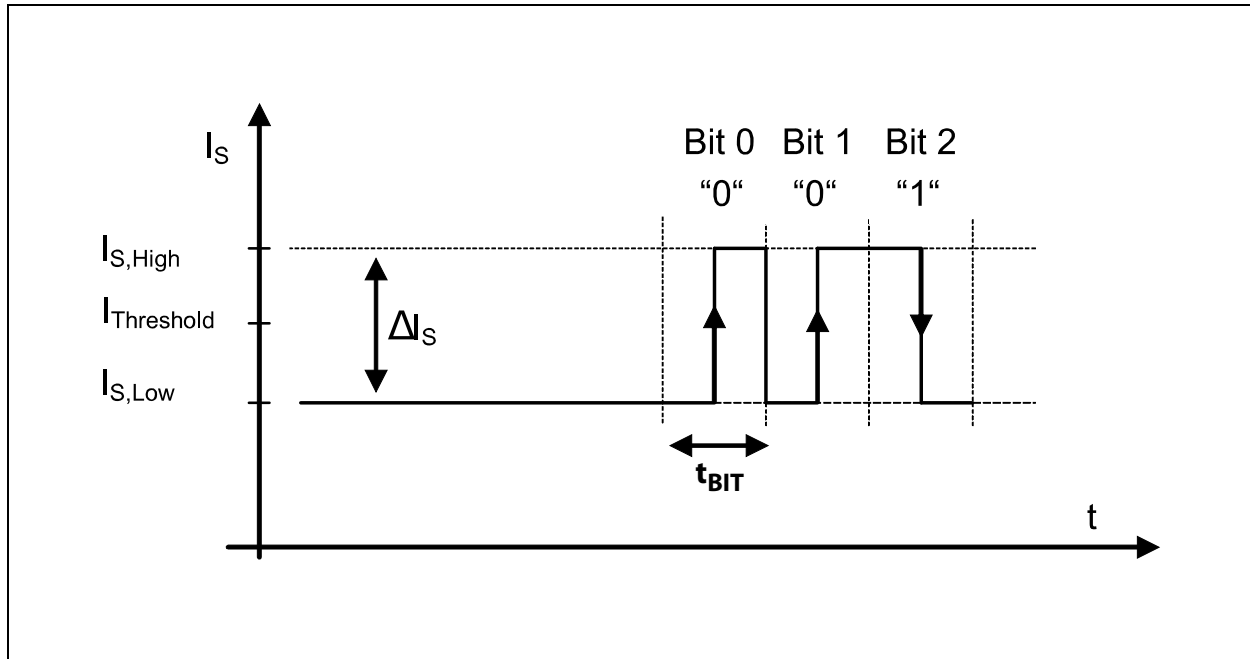

Manchester coding is used for data transmission. A logic "0" is represented by a rising slope and a logic "1" by a falling slope of the current in the middle of t_{BIT} .

Figure 40:
Bit Encoding Timing

Symbol	Parameter	Min	Typ	Max	Unit	Comments
t_{Bit_L}	Bit Time (125 kbit/s mode)		8		μs	16 CLK cycles of the internal 2 MHz clock
t_{Bit_H}	Bit Time (189 kbit/s mode)		5.3		μs	14 CLK cycles of the internal 2.67 MHz clock

Data Frames - AS5172 to ECU Communication

Each PS15 data frame consists of N bits containing two start bits and one parity bit with even parity (or 3 CRC bits) and N-3 (N-5) data bits. Data bits are transmitted LSB first. The data frames are sent periodically from the sensor to the ECU. A minimum gap time t_{Gap} larger than one maximum bit duration t_{Bit} is required between two data frames.

Figure 41:
Example of a 10-Bit Data Frame

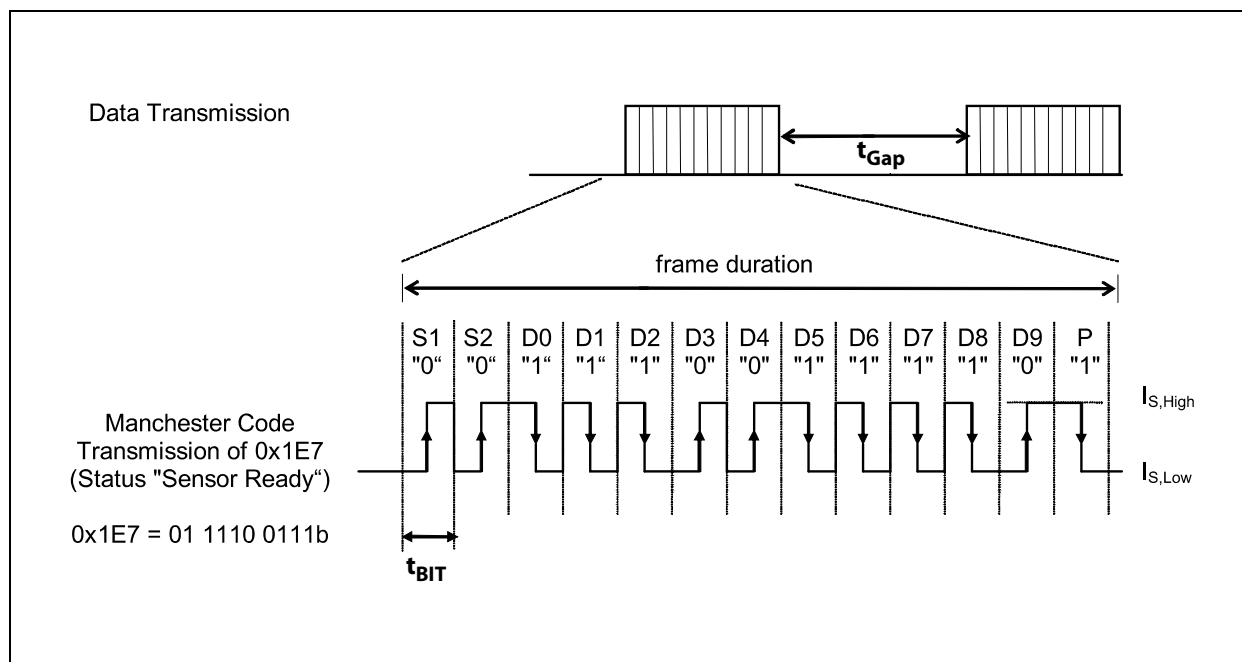

Data Ranges

The AS5172 supports the data range according PS15 standard V2.1 and V1.3.

PS15 data messages are divided into three separate ranges: A data range for the sensor output signal, a range for status and error messages and a range for initialization data.

Data Range According PS15 V1.3

If AS5172 is used in the 10-bit mode, the decimal values -480 to +480 are used for the sensor output signal. The range -512 to -481 is reserved block and data IDs which are used for transmitting initialization data during startup of the AS5172. The range from +481 to +511 is used for status and error messages.

The 10 bit data range is used only in the LowRes mode of the sensor. The 12 bit output value from the DSP has to be mapped to the data range of -480 to +480 (10 bit, signed) by taking only the 10 higher order bits, subtracting the mid-code, and apply clamping to the data range of -480 to +480.

Figure 42:
Data Range for 10-Bit Mode

Dec	Hex	Signification	Range	
+511	0x1FF	Reserved (ECU internal use) *1	Status and Error Messages	2
:	:	Reserved (ECU internal use) *1		
+504	0x1F8	Reserved (ECU internal use) *1		
+503	0x1F7	Reserved (Sensor use) *2		
+502	0x1F6	Reserved (Sensor use) *2		
+501	0x1F5	Reserved (Sensor use) *2		
+500	0x1F4	“Sensor Defect”		
+499	0x1F3	Reserved (ECU internal use) *1		
:	:	Reserved (ECU internal use) *1		
+496	0x1F0	Reserved (ECU internal use) *1		
+495	0x1EF	Reserved (Sensor use) *2		
:	:	Reserved (Sensor use) *2		
+489	0x1E9	“Sensor in Diagnostic Mode”		
+488	0x1E8	“Sensor Busy”		
+487	0x1E7	“Sensor Ready”		
+486	0x1E6	“Sensor Ready but Unlocked”		
+485	0x1E5	Reserved (Sensor use) *2		
+484	0x1E4	Reserved (Sensor use) *2		
+483	0x1E3	Reserved (Sensor use) *2		
+482	0x1E2	Bidirectional Communication: RC “Error”		
+481	0x1E1	Bidirectional Communication: RC “OK”		
+480	0x1E0	Highest Positive Sensor Signal	Sensor Output Signal	1
:	:	:		
0	0x000	Signal Amplitude “0”		
:	:	:		
-480	0x220	Highest Negative Sensor Signal		

Dec	Hex	Signification	Range	
-481	0x21F	Status Data 1111	Block ID's and Data for Initialization	3
:	:	:		
-496	0x210	Status Data 0000		
-497	0x20F	Block ID 16		
:	:	:		
-512	0x200	Block ID 1		

When using the AS5172 in 10-bit mode the data frame consists of 2 start bits (S1, S2), 10 data bits (D0-D9) which represent the angle and an even parity bit (P).

Figure 43:
Data Frame for 10-Bit Mode

Start Bits		10-Bit Sensor Data (LSB first)										Parity
S1	S2	A0	A1	A2	A3	A4	A5	A6	A7	A8	A9	P
0	0	D0	D1	D2	D3	D4	D5	D6	D7	D8	D9	P

The AS5172 has also the possibility to provide the 12-bit angle value in the PSI5 V1.3 specification.

The substandard vehicle describes this method to map a 12-bit word into a 16 bit data frame and splitting of this into two 10-bit frames.

Data Range According PS15 V2.1

If AS5172 is used in the 20-bit mode, the decimal values –30720 to +30720 are used for the sensor output signal. The range –32768 to –30784 is reserved block and data IDs which are used for transmitting initialization data during startup of the AS5172. The range from +31168 to +32767 is used for status and error messages.

Figure 44:
Data Range for 20-Bit Mode

Dec	Hex	Signification	Range	
32767	0x7FFF	Reserved (ECU internal use)	Status and Error Messages	2
+31168	0x79FF	“Sensor Ready”		
:	:			
+30720	0x7800	Highest Positive Sensor Signal	Sensor Output Signal	1
:	:	:		
0	0x0000	Signal Amplitude “0”		
:	:	:		
-30720	0x8800	Highest Negative Sensor Signal		
-30784	0x87FF	Status Data 1111	Block ID's and Data for Initialization	3
:	:	:		
-31744	0x8400	Status Data 0000		
-31808	0x83FF	Block ID 16		
:	:	:		
-32768	0x8000	Block ID 1		

PSI5 Data Frame 20-Bit Mode with 12-Bit Sensor Data

In 20-bit mode the PSI5 frame consists of 2 start bits (S1, S2), 3 frame control bits (F0, F1, F2), an error status bit (E0), 16 data bits (A0 to A15), and 3 CRC bits (C2, C1, C0).

As described in chapter [Rolling Counter](#) the 3 frame control bits can be used as rolling counter. The error status bit is used to indicate a failure of the sensor to ECU (E0 = 1). If no failure is present this bit is always set to 0. The 12-bit angle information is transmitted on A0 – A11. The upper fields A12 – A15 are set to 0.

Figure 45:
PSI5 Data Frame 20-Bit Mode with 12-Bit Sensor Data

Start Bits		Frame Control			Error Status	12-Bit Sensor Data (LSB first)												CRC						
S1	S2	F0	F1	F2	E0	A0	A1	A2	A3	A4	A5	A6	A7	A8	A9	A10	A11	A12	A13	A14	A15	C2	C1	C0
0	0	C0	C1	C2	E0	D0	D1	D2	D3	D4	D5	D6	D7	D8	D9	D10	D11	0	0	0	0	C2	C1	C0

PSI5 Data Frame 20-Bit Mode with 12-Bit Sensor Data and Quadrant Detection

For safety relevant applications, where multiple quadrant mode is used, additionally to the 12-bit angle information a quadrant information can be transmitted in A12 and A13. For more information refer to chapter [Multiple Quadrants](#).

Figure 46:
PSI5 Data Frame 20-Bit Mode with 12-Bit Sensor Data and Quadrant Detection

Start Bits		Frame Control			Error Status	12-Bit Sensor Data (LSB first)												Quadrant Info		CRC				
S1	S2	F0	F1	F2	E0	A0	A1	A2	A3	A4	A5	A6	A7	A8	A9	A10	A11	A12	A13	A14	A15	C2	C1	C0
0	0	C0	C1	C2	E0	D0	D1	D2	D3	D4	D5	D6	D7	D8	D9	D10	D11	Q0	Q1	0	0	C2	C1	C0

Figure 47:
Quadrant Information

Quadrant	Quadrant Mode	Quadrant Info on PS15
00	Single	Q1 = 00 Q2 = 01
01	Dual	Q1 = 00 Q2 = 01
10	Triple	Q1 = 00 Q2 = 01 Q3 = 10
11	Quadruple	Q1 = 00 Q2 = 01 Q3 = 10 Q4 = 11

PSI5 Data Frame 20-Bit Mode with 14-Bit Sensor Data

For special applications where the full sensor resolution is necessary over a 360° rotation the AS5172 features a special 14-bit mode. In this mode the 14-bit angle information is transmitted from A0 – A13. A14 and A15 are filled with 0. For more information refer to chapter [14-Bit Mode](#).

Figure 48:
PSI5 Data Frame 20-Bit Mode with 14-Bit Sensor Data

Start Bits		Frame Control			Error Status	14-Bit Sensor Data (LSB first)														CRC				
S1	S2	F0	F1	F2	E0	A0	A1	A2	A3	A4	A5	A6	A7	A8	A9	A10	A11	A12	A13	A14	A15	C2	C1	C0
0	0	C0	C1	C2	E0	D0	D1	D2	D3	D4	D5	D6	D7	D8	D9	D10	D11	D12	D13	0	0	C2	C1	C0

PSI5 Data Frame 16-Bit Mode

In 16-bit mode the PSI5 frame consists of 2 start bits (S1, S2), an error status bit (E0), 15 data bits (A0 to A14), and 3 CRC bits (C2, C1, C0).

The error status bit is used to indicate a failure of the sensor to ECU (E0 = 1). If no failure is present this bit is always set to 0. The 16-bit frame can transmit the 12-bit angle information (A0 – A11) but also the 14-bit angle by activating the 14-bit mode in the OTP. (A0 – A13). The field A14 is by default set to 0 but can also be used as a toggle bit by activating the Rolling Counter.

Figure 49:
PSI5 Data Frame 16-Bit Mode with 12-Bit Sensor Data

Start Bits		Error Status	14-Bit Sensor Data (LSB first)														CRC			
S1	S2	E0	A0	A1	A2	A3	A4	A5	A6	A7	A8	A9	A10	A11	A12	A13	A14	C2	C1	C0
0	0	E0	D0	D1	D2	D3	D4	D5	D6	D7	D8	D9	D10	D11	D12	D13	0	C2	C1	C0

PSI5 Modes

The AS5172 can be configured in several PSI5 modes according standard V1.3 and V2.1. This modes can be selected via registers 0x01, 0x11 and 0x12. The tables in [Figure 45](#) and [Figure 46](#) show the different modes.

Independent from the specific mode also other options can be activated in this registers:

- Low Power Mode (set bit[2] in register 0x11)
- Initialization Phase Repetition Factor
- Extended Initialization Phase (32 blocks)
- Rolling Counter (set bit[7] in register 0x11)
- 14-Bit Mode
- Velocity Extended Range

Figure 50:
PSI5 Modes V1.3

PSI5 Mode	Timeslot	Discharge	High Resolution	Register	
				0x11	0x12
P10P-500/3L	Timeslot 1	-	-	0x00	0x00
P10P-500/3L	Timeslot 2	-	-	0x00	0x08
P10P-500/3L	Timeslot 3	-	-	0x00	0x10
P10P-500/3L	Timeslot 2	X	-	0x00	0x09
P10P-500/3L	Timeslot 3	X	-	0x00	0x11
P10P-500/3L	Timeslot 1 and 2	-	X	0x40	0x00
P10P-500/3L	Timeslot 2 and 3	-	X	0x40	0x08
P10P-500/3L	Timeslot 2 and 3	X	X	0x40	0x09
A10P-500/1L	-	-	-	0x10	0x00
A10P-250/1L	-	-	-	0x30	0x00
A10P-500/1L	-	-	X	0x50	0x00
A10P-250/1L	-	-	X	0x70	0x00

Figure 51:
PSI5 Modes V2.1

PSI5 Mode	Timeslot Angle	Timeslot Velocity	Register		
			0x01	0x11	0x12
P20CRC-500/1L	Timeslot 1	-	0x00	0x02	0x00
P20CRC-500/2L	Timeslot 2	-	0x00	0x02	0x08
P20CRC-500/2L	Timeslot 1	Timeslot 2	0x00	0x02	0x40
P20CRC-500/2H	Timeslot 1	-	0x00	0x03	0x00
P20CRC-500/2H	Timeslot 2	-	0x00	0x03	0x08
P20CRC-500/2H	Timeslot 1	Timeslot 2	0x00	0x30	0x48
P20CRC-500/3H	Timeslot 1	-	0x00	0x0B	0x00
P20CRC-500/3H	Timeslot 2	-	0x00	0x0B	0x08
P20CRC-500/3H	Timeslot 3	-	0x00	0x0B	0x10
P20CRC-500/3H	Timeslot 1	Timeslot 2	0x00	0x0B	0x48
P20CRC-500/3H	Timeslot 2	Timeslot 3	0x00	0x0B	0x50
P20CRC-500/3H	Timeslot 1	Timeslot 3	0x00	0x0B	0x58
P16CRC-500/3H	Timeslot 1	-	0x20	0x01	0x00
P16CRC-500/3H	Timeslot 2	-	0x20	0x01	0x08
P16CRC-500/3H	Timeslot 3	-	0x20	0x01	0x10
P16CRC-500/3H	Timeslot 1	Timeslot 2	0x20	0x01	0x48
P16CRC-500/3H	Timeslot 2	Timeslot 3	0x20	0x01	0x50
P16CRC-500/3H	Timeslot 1	Timeslot 3	0x20	0x01	0x58
A20CRC-200/1H	-	-	0x00	0x33	0x00
A20CRC-500/1H	-	-	0x00	0x13	0x00
A20CRC-500/2H	-	-	0x00	0x1B	0x00
A20CRC-300/1L	-	-	0x00	0x12	0x00

PSI5 Timing

The following chapter describes the timings for the different PSI5 modes.

The timing is according the internal clock rate of 2 MHz or 2.67 MHz respectively. This clock rates are derived from the main clock of 16 MHz with a $\pm 3.5\%$ variation.

Timing Synchronous Mode P10P-500/3L

Figure 52:
Synchronous Mode P10P-500/3L

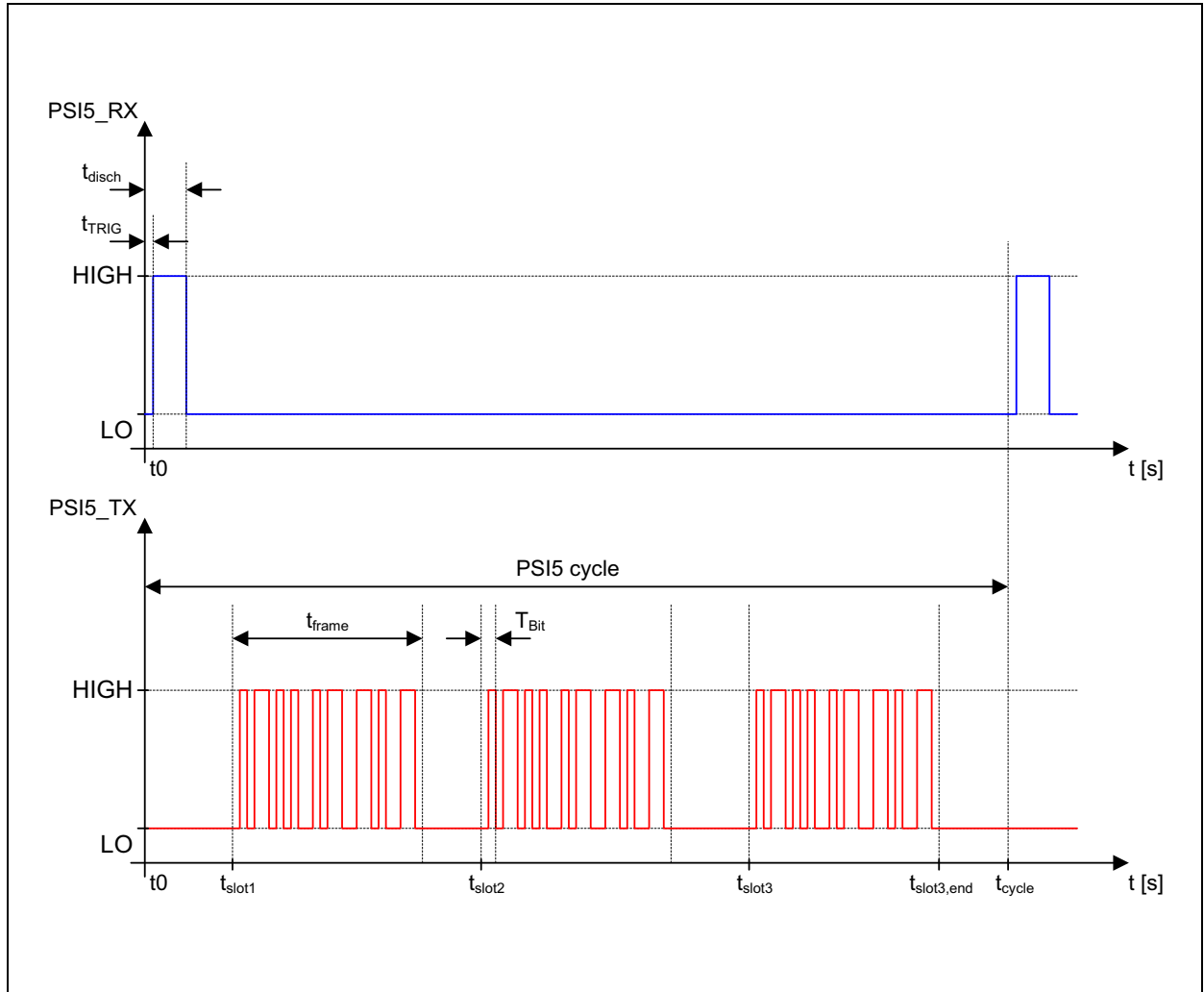

Figure 53:
Timings Parameters of P10P-500/3L

Symbol	Parameter	Min	Typ	Max	Unit	Comments
$t_{\text{Bit_L}}$	Bit Time	7.7	8	8.3	μs	16 CLK cycles of the internal 2 MHz clock
$t_{\text{frame_10L}}$	Frame Duration	100.4	104	107.6	μs	208 CLK cycles of the internal 2 MHz clock
t_{TRIG}	Trigger Detection Time	0	4.5	10	μs	From start of synch. pulse
t_{slot1}	Start of Time Slot 1	44	51	59	μs	88 CLK cycles of the internal 2 MHz clock
t_{slot2}	Start of Time Slot 2	181.3	195	210	μs	376 CLK cycles of the internal 2 MHz clock
t_{slot3}	Start of Time Slot 3	328.9	350	372.8	μs	686 CLK cycles of the internal 2 MHz clock
$t_{\text{slot3,end}}$	End of Time Slot 3	427.7	454	482	μs	
$t_{\text{cycle,P500}}$	Cycle Time P10P-500/3L	250	500	-	μs	

Timing Synchronous Mode P10P-500/3L with Discharge Pulse

Figure 54:
Synchronous Mode P10P-500/3L with Discharge Pulse

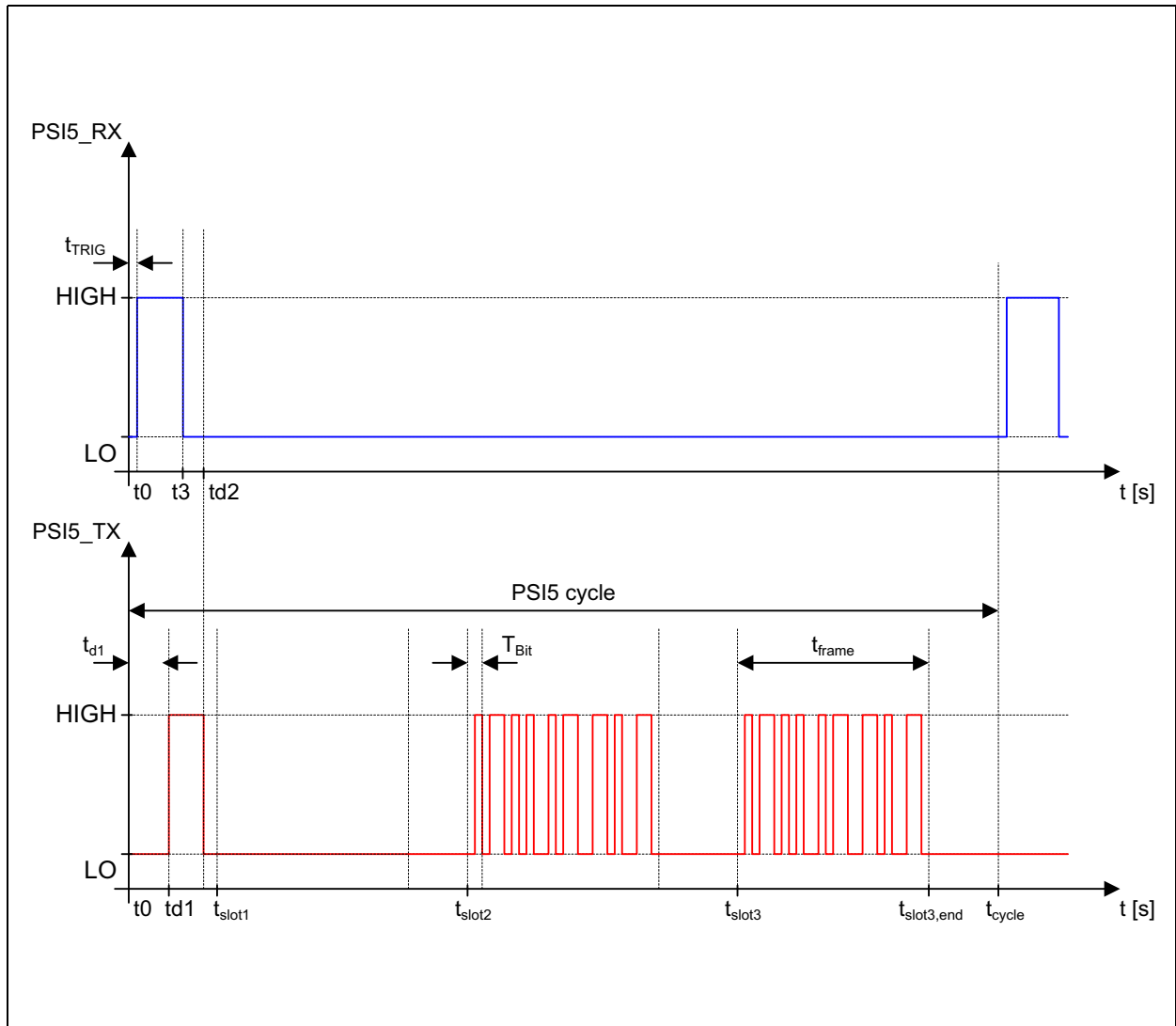

Figure 55:
Timings Parameters of P10P-500/3L with Discharge Pulse

Symbol	Parameter	Min	Typ	Max	Unit	Comments
$t_{\text{Bit_L}}$	Bit Time	7.7	8	8.3	μs	16 CLK cycles of the internal 2 MHz clock
$t_{\text{frame_10L}}$	Frame Duration	100.4	104	107.6	μs	208 CLK cycles of the internal 2MHz clock
t_{TRIG}	Trigger Detection Time	0	3.25	7.5	μs	From start of synch. pulse
td1	Signal Discharge	18.5	22.75	28	μs	39 CLK cycles of the internal 2 MHz clock
td2	Discharge Stop Time	38	43.25	50	μs	80 CLK cycles of the internal 2 MHz clock
t_{slot1}	Start of Time Slot 1	44	51	59	μs	88 CLK cycles of the internal 2 MHz clock
t_{slot2}	Start of Time Slot 2	181.3	195	210	μs	376 CLK cycles of the internal 2 MHz clock
t_{slot3}	Start of Time Slot 3	328.9	350	372.8	μs	686 CLK cycles of the internal 2 MHz clock
$t_{\text{slot3,end}}$	End of Time Slot 3	427.7	454	482	μs	
$t_{\text{cycle,P500}}$	Cycle Time P10P-500/3L	250	500	-	μs	

Timing Asynchronous Modes A10P-250/1L and A10P-500/1L

Figure 56:
Asynchronous Modes A10P- 50/1L and A10P-500/1L

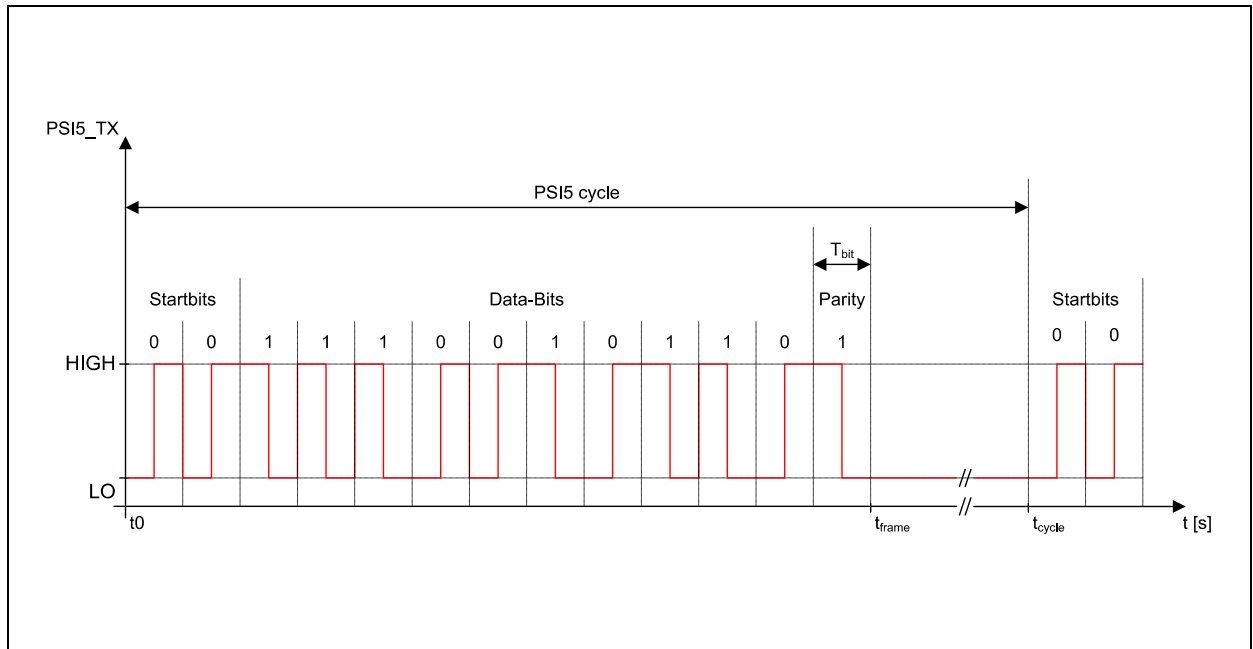

Figure 57:
Timings Parameters of A10P- 50/1L and A10P-500/1L

Symbol	Parameter	Min	Typ	Max	Unit	Comments
t_{Bit_L}	Bit Time	7.7	8	8.3	μs	16 CLK cycles of the internal 2 MHz clock
t_{frame_10L}	Frame Duration	100.4	104	107.6	μs	208 CLK cycles of the internal 2 MHz clock
$t_{cycle,250L}$	Cycle Time A10P-250/1L	241.2	250	258.8	μs	500 CLK cycles of the internal 2 MHz clock
$t_{cycle,500L}$	Cycle Time A10P-500/1L	482.5	500	517.5	μs	1000 CLK cycles of the internal 2 MHz clock

**Timing Synchronous Modes P20CRC-500/1L,
P20CRC-500/2L, P20CRC-500/2H, P20CRC-500/3H,
P16CRC-500/3H**

The supported protocol modes for synchronous transmission with 20bit format are P20CRC-500/1L, P20CRC-500/2L, P20CRC-500/2H and P20CRC-500/3H. For all these modalities except P20CRC-500/1L it is possible to select also the velocity output. In this case two consecutive timeslots will be used.

The protocol P20CRC-500/3H is specifically studied for sensors that must transmit more data on two consecutive timeslots (e.g. angle and velocity). Usually there should be on the bus one sensor transmitting data on timeslot 1 & 2 and another sensor transmitting on timeslot 3, or a sensor transmitting on timeslot 1 and another transmitting on timeslot 2 & 3. Because of the relative tolerances due to the different clocks on the different sensors, the timing of the second timeslot is different when the sensor is transmitting only on one timeslot (not legacy situation for timeslot 2 only but allowed) and when is transmitting also the velocity using 2 consecutive timeslots, differentiating from the case of timeslot 1 & 2 or timeslot 2 & 3.

When there is a new synchronization pulse from the ECU before the current transmission of the AS5172 is finished the current transmission must be stopped and a new transmission has to be started in the programmed time slots.

Figure 58:
**Timing Parameters of Synchronous Modes P20CRC-500/1L,P20CRC-500/2L, P20CRC-500/2H,
P20CRC-500/3H**

Symbol	Parameter	Min	Typ	Max	Unit	Comments
$t_{\text{Bit_L}}$	Bit Time P20CRC-500/1L/2L	7.7	8	8.3	μs	16 CLK cycles of the internal 2 MHz clock
$t_{\text{frame_20L}}$	Frame Duration P20CRC-500/1L/2L	193	200	207	μs	400 CLK cycles of the internal 2 MHz clock
$T_{\text{Bit_H}}$	Bit Time P20CRC-500/2H/3H	5.06	5.25	5.44	μs	14 CLK cycles of the internal 2.67 MHz clock
$t_{\text{frame_20H}}$	Frame Duration P20CRC-500/2H/3H	126.66	131.25	135.84	μs	350 CLK cycles of the internal 2.67 MHz clock
t_{TRIG}	Trigger Detection Time	0	4.5	10	μs	From start of synch. pulse
$t_{\text{slot1_20L}}$	Start of Time Slot 1 P20CRC-500/1L/2L	44	48.5	56	μs	88 CLK cycles of the internal 2 MHz clock

Symbol	Parameter	Min	Typ	Max	Unit	Comments
$t_{\text{slot1_20L,end}}$	End of Time Slot 1 P20CRC-500/1L/2L	234	251	269	μs	400 CLK cycles of the internal 2 MHz clock
$t_{\text{slot1_20H}}$	Start of Time Slot 1 P20CRC-500/2H	44	51	59	μs	119 CLK cycles of the internal 2.67 MHz clock
$t_{\text{slot1_20H,end}}$	End of Time Slot 1 P20CRC-500/2H	169	182.25	198	μs	
$t_{\text{slot1_20H}}$	Start of Time Slot 1 P20CRC-500/3H	44	45	56	μs	112 CLK cycles of the internal 2.67 MHz clock
$t_{\text{slot1_20H,end}}$	End of Time Slot 1 P20CRC-500/3H	175.4	177.5	190.5	μs	
$t_{\text{slot2_20L}}$	Start of Time Slot 2 P20CRC-500/2L	267.5	273	288	μs	540 CLK cycles of the internal 2 MHz clock
$t_{\text{slot2_20L,end}}$	End of Time Slot 2 P20CRC-500/2L	464	473	492	μs	
$t_{\text{slot2_20H}}$	Start of Time Slot 2 P20CRC-500/2H	203.5	218.25	235.5	μs	570 CLK cycles of the internal 2.67 MHz clock
$t_{\text{slot2_20H,end}}$	End of Time Slot 2 P20CRC-500/2H	328.5	349.5	374.5	μs	
$t_{\text{slot2_20H}}$	Start of Time Slot 2 P20CRC-500/3H	183	186.5	199.5	μs	490 CLK cycles of the internal 2.67 MHz clock
$t_{\text{slot2_20H,end}}$	End of Time Slot 2 P20CRC-500/3H	313.5	319	334	μs	
$t_{\text{slot2_20H}}$	Start of Time Slot 2 P20CRC-500/3H with Velocity on Time Slot 1 & 2	180	183.5	196.5	μs	482 CLK cycles of the internal 2.67 MHz clock
$t_{\text{slot2_20H,end}}$	End of Time Slot 2 P20CRC-500/3H with Velocity on Time Slot 1 & 2	310.5	316	331	μs	
$t_{\text{slot2_20H}}$	Start of Time Slot 2 P20CRC-500/3H with Velocity on Time Slot 2 & 3	195.5	199	212	μs	524 CLK cycles of the internal 2.67 MHz clock
$t_{\text{slot2_20H,end}}$	End of Time Slot 2 P20CRC-500/3H with Velocity on Time Slot 2 & 3	326	331.5	346.5	μs	

Symbol	Parameter	Min	Typ	Max	Unit	Comments
$t_{\text{slot3_20H}}$	Start of Time Slot 3 P20CRC-500/3H	336	341.5	357	μs	905 CLK cycles of the internal 2.67 MHz clock
$t_{\text{slot3_20H,end}}$	End of Time Slot 3 P20CRC-500/3H	466.5	474	491.5	μs	
$t_{\text{cycle,P500}}$	Cycle Time P20CRC-500/1L/2L	270	500	-	μs	
$t_{\text{cycle,P500}}$	Cycle Time P20CRC-500/2H/3H	250	500	-	μs	

For P16CRC-500/3H mode, bit timings and the frame start timings are the same as of the P20CRC-500/3H mode. All other timings are reported in table below:

Figure 59:
Distinct Timing Parameters of P16CRC-500/3H

Symbol	Parameter	Min	Typ	Max	Unit	Comments
$t_{\text{frame_16H}}$	Frame Duration P16CRC-500/3H	106.4	110.25	114.1	μs	294 CLK cycles of the internal 2.67 MHz clock
$t_{\text{slot1_16H,end}}$	End of Time Slot 1 P16CRC-500/3H	153.5	156.5	169.5	μs	
$t_{\text{slot2_16H,end}}$	End of Time Slot 2 P16CRC-500/3H	292.5	298	313	μs	
$t_{\text{slot3_16H,end}}$	End of Time Slot 3 P16CRC-500/3H	445.5	453	470.5	μs	

Timing Asynchronous Modes A20CRC-200/1H and A20CRC-300/1L

Figure 60:
Asynchronous Modes A20CRC-200/1H and A20CRC-300/1L

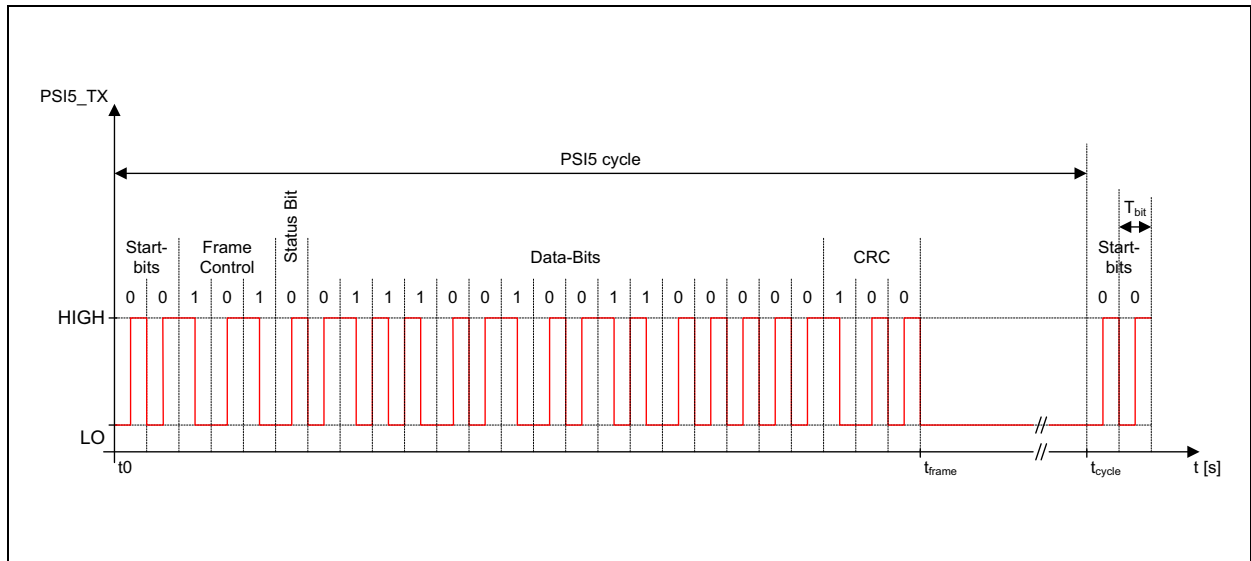

Figure 61:
Timing Parameters of A20CRC-200/1H and A20CRC-300/1L

Symbol	Parameter	Min	Typ	Max	Unit	Comments
$t_{\text{Bit_L}}$	Bit Time A20CRC-300/1L	7.7	8	8.3	μs	16 CLK cycles of the internal 2 MHz clock
$t_{\text{frame_20L}}$	Frame Duration A20CRC-300/1L	193	200	207	μs	400 CLK cycles of the internal 2 MHz clock
$t_{\text{cycle_300L}}$	Cycle Time A20CRC-300/1L	298.5	300	310.5	μs	600 CLK cycles of the internal 2 MHz clock
$t_{\text{Bit_H}}$	Bit Time A20CRC-200/1H	5.06	5.25	5.44	μs	14 CLK cycles of the internal 2.67 MHz clock
$t_{\text{frame_20H}}$	Frame Duration A20CRC-200/1H	126.66	131.25	135.84	μs	350 CLK cycles of the internal 2.67 MHz clock
$t_{\text{cycle_200H}}$	Cycle Time A20CRC-200/1H	193	200	207	μs	533 CLK cycles of the internal 2.67 MHz clock

PSI5 Initialization

The Startup and Initialization is working according the PSI5 standard.

After each power on or undervoltage reset, the AS5172 performs an internal initialization which is divided into three phases:

Figure 62:
Start-Up and Initialization

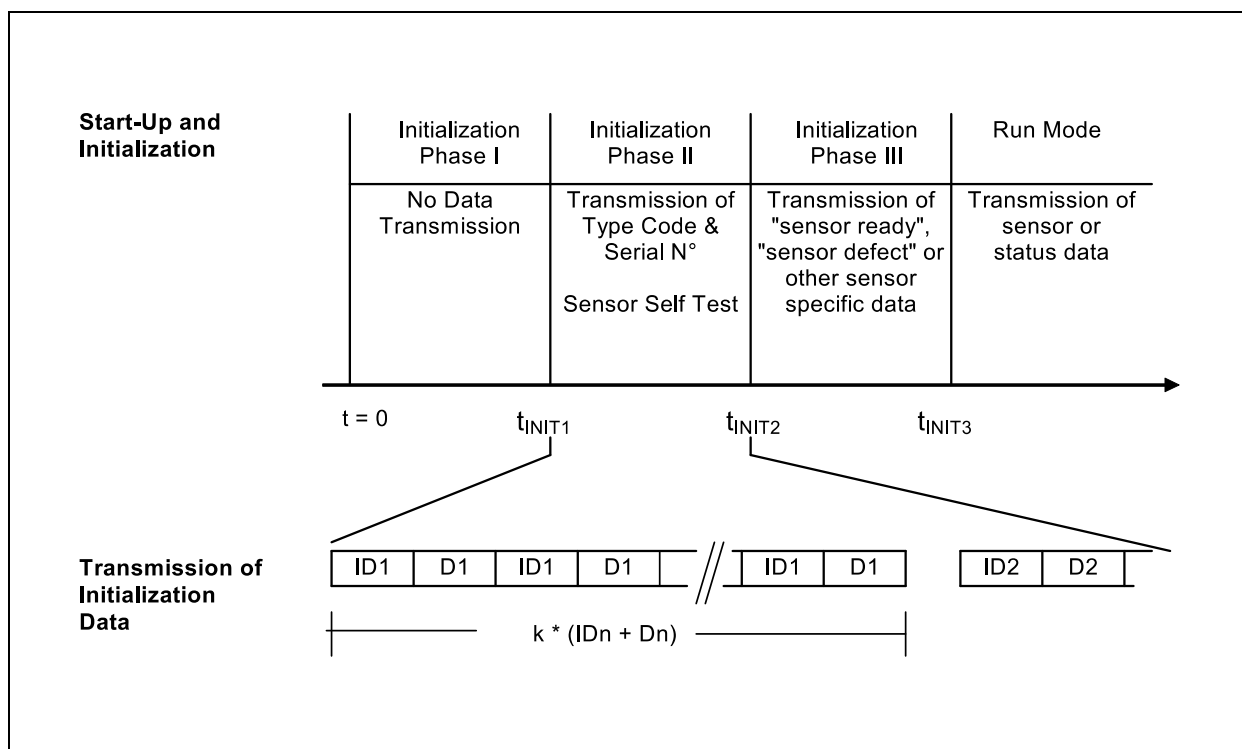

Initialization Phase I

During the first initialization phase, no data is transmitted and the ECU can perform a connectivity test. Duration 50 – 150ms; typical 100ms. If using synchronous transmission mode the ECU can terminate the initialization phase I by sending the sync pulse at least 4ms after AS5172 power on.

Initialization Phase II

During the second initialization phase, the AS5172 transmits sensor and application specific information to the ECU.

In High Resolution mode the AS5172 transmits the same PSI5 frame on both programmed time slots. The same is valid if the velocity output is activated.

For the 20-bit mode the 10-bit values are extended to 20 bits. This is done by shifting the data bits [9:0] to bits A15 to A6. The remaining 6 LSBs are filled with "0". The frame control bits (F0 to F2) and the status bit (E0) are at "0".

Figure 63:
Initialization Phase in 20-Bit Mode

Start Bits		Frame Control			Error Status	16-Bit Sensor Data (LSB first)																CRC			
S1	S2	F0	F1	F2	E0	A0	A1	A2	A3	A4	A5	A6	A7	A8	A9	A10	A11	A12	A13	A14	A15	C2	C1	C0	
0	0	0	0	0	0	0	0	0	0	0	0	0	D0	D1	D2	D3	D4	D5	D6	D7	D8	D9	C2	C1	C0

Figure 64:
Initialization Phase in 16-Bit Mode

Start Bits		Error Status	15-Bit Sensor Data (LSB first)															CRC			
S1	S2	E0	A0	A1	A2	A3	A4	A5	A6	A7	A8	A9	A10	A11	A12	A13	A14	C2	C1	C0	
0	0	0	0	0	0	0	0	0	D0	D1	D2	D3	D4	D5	D6	D7	D8	D9	C2	C1	C0

Initialization Phase III

During the third initialization phase, the sensor transmits “Sensor Ready”, “Sensor Defect” or other status data. If the sensor is defective, it will continue to send the “Sensor Defect” messages and other optional status data until it is powered off.

“Sensor Ready” Code 0x1E7 at A15 to A6 – if the sensor is OK

“Sensor Defect” Code 0x1F4 at A15 to A6 – if there is a diagnostic error

In High Resolution mode the AS5172 transmits the same PSI5 frame on both programmed time slots. The same is valid if the velocity output is activated.

In overvoltage, undervoltage case and AGC High, Low the AS5172 is not reporting this errors in initialization phase III but it will send the error code in the run mode

Initialization Phase Data Format

ID blocks and data blocks are sent in an alternating sequence, “k” times each. The block identifiers are used for a numbering of the following data nibbles. After any power-on or undervoltage reset, the internal logic starts up with an initialization program. The factor “k” can vary between 1 and 4 and can be configured with “Init_phase_repetition” in register 0x12.

Figure 65:
Block ID and Data Nibbles

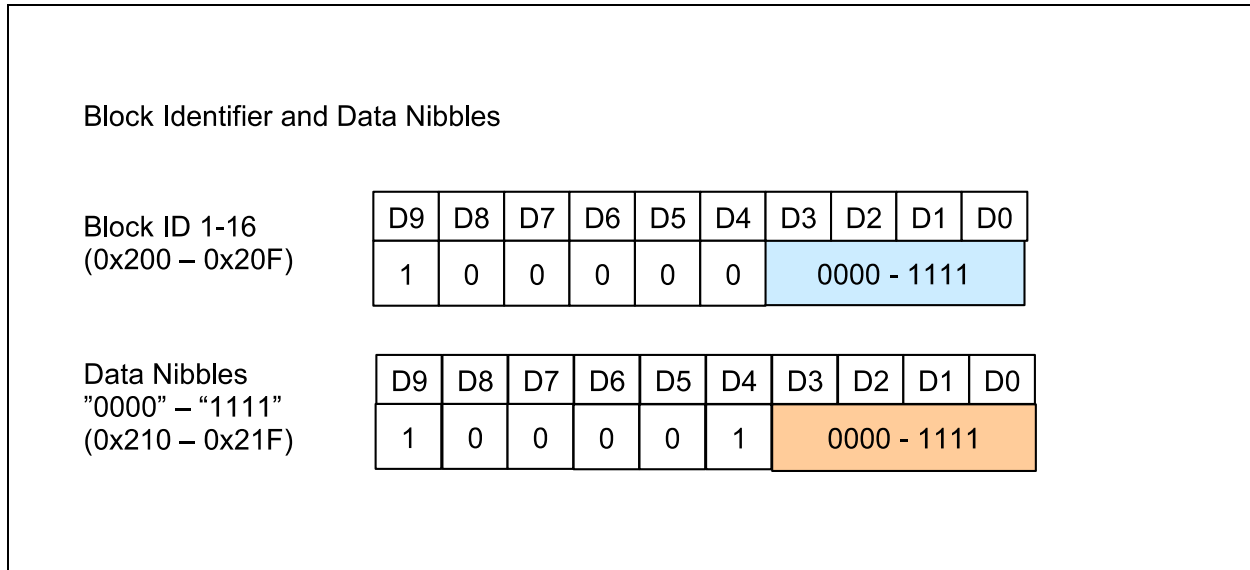
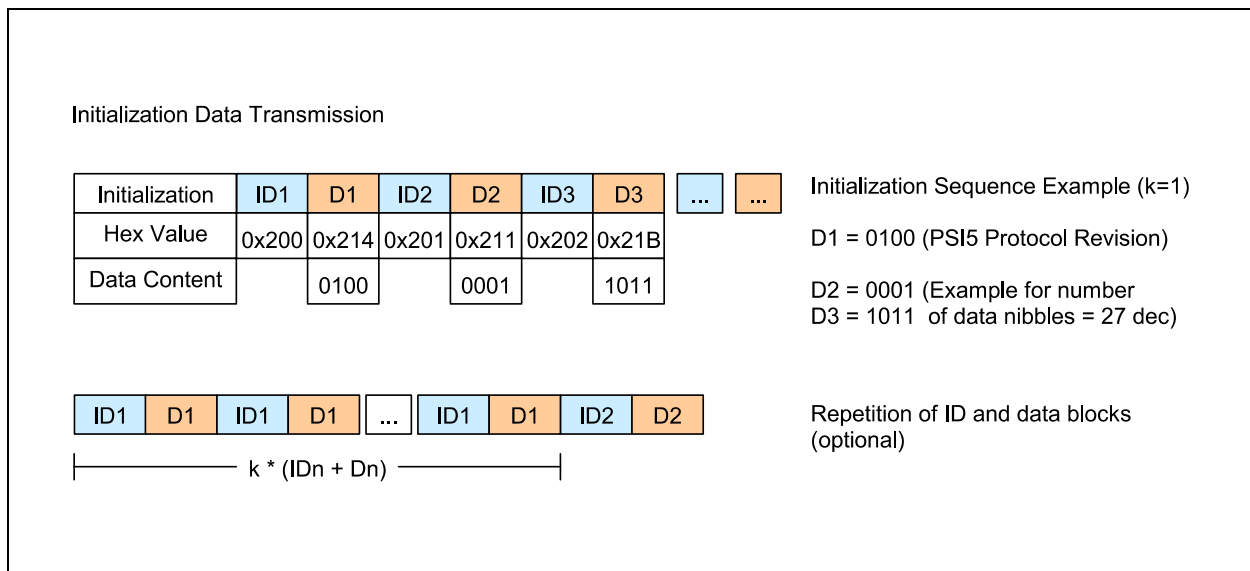

Figure 66:
Startup Sequence



Initialization Data Content

During the second initialization phase, the AS5172 transmits sensor and application specific information to the ECU. Those informations are described into [Figure 67](#).

Figure 67:
Initialization Content

Field ID#	Nibble ID#	Name	Description	Register Address	Value
F1	D1	Protocol revision	PSI5 V1.3	Hard-coded	0100
			PSI5 V2.1	Hard-coded	0110
F2	D2, D3	Number of data blocks	Number of data blocks = 22	Hard-coded	0001 0000
			Number of data blocks = 32	Hard-coded	0010 0110
F3	D4, D5	Manufacturer code	Vendor ID	0x1E	Customer
F4	D6, D7	Sensor type	Sensor type	0x0E	Customer
F5	D8, D9	Sensor parameter	Sensor parameter	0x0E, 0x0F	Customer
F6	D10, D11	Sensor code (sensor)	Sensor code (sensor)	0x0F, 0x10	Customer
F7	D12	Sensor code (vehicle)	Sensor code (vehicle)	0x10	Customer
F8	D13 – D16	Production date	Production date	0x0C, 0x0D	Customer
F9	D17 – D22	Lot and serial number	ams ID	0x02, 0x03, 0x04	Factory

Run Mode

After finishing Initialization Phase III the AS5172 enters Run Mode. If the sensor is configured in asynchronous mode it will start transmitting data continuously according PSI5 standard. Using the synchronous mode, the transmission is triggered by a sync pulse of the ECU.

If the AS5172 is configured in asynchronous mode, it will transmit the data continuously according the PSI5 Specification.

In case of an application or sensor error, AS5172 is performing in run mode according the description in chapter [Diagnostic](#).

Communication Modes

Asynchronous Mode (PSI5-A)

PSI5-A describes a point-to-point connection for unidirectional, asynchronous data transmission.

Each sensor is connected to the ECU by two wires. After switching on the power supply, the sensor starts transmitting data to the ECU periodically. Timing and repetition rate of the data transmission are controlled by the sensor.

Figure 68:
Asynchronous Single Sensor Configuration

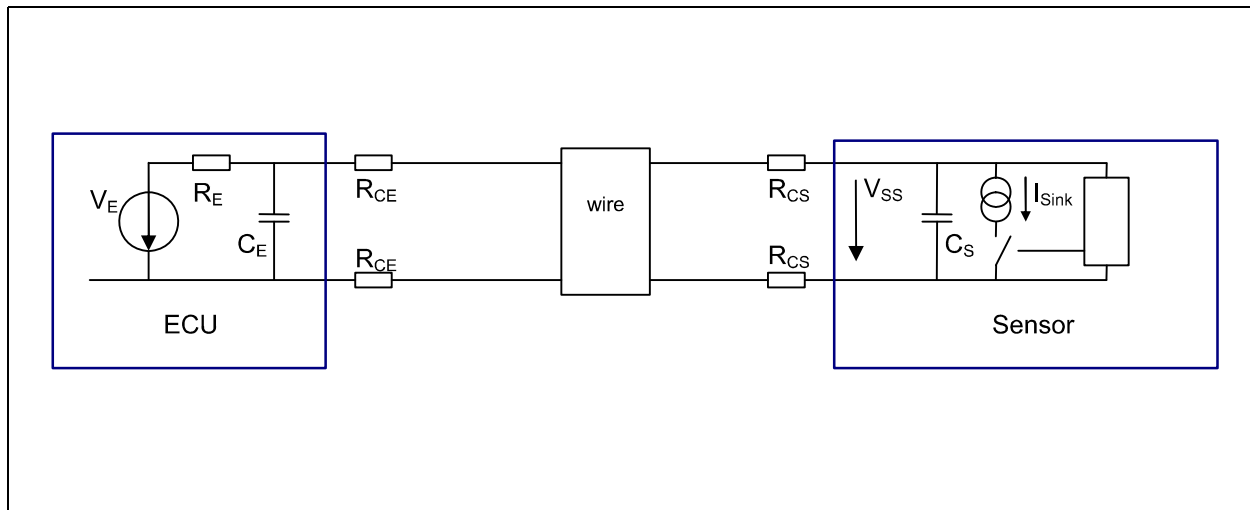

Synchronous Parallel Bus Mode (PSI5-P)

PSI5-P describes a bus configuration for synchronous data transmission of one or more sensors. Each sensor is connected to the ECU by a separate pair of wires (star topology). Each data transmission period is initiated by a voltage synchronization signal from the ECU to the sensors. Having received the synchronization signal, each sensor starts transmitting its data with the corresponding time shift in the assigned time slot.

Figure 69:
Synchronous Parallel Bus Mode (PSI5-P)

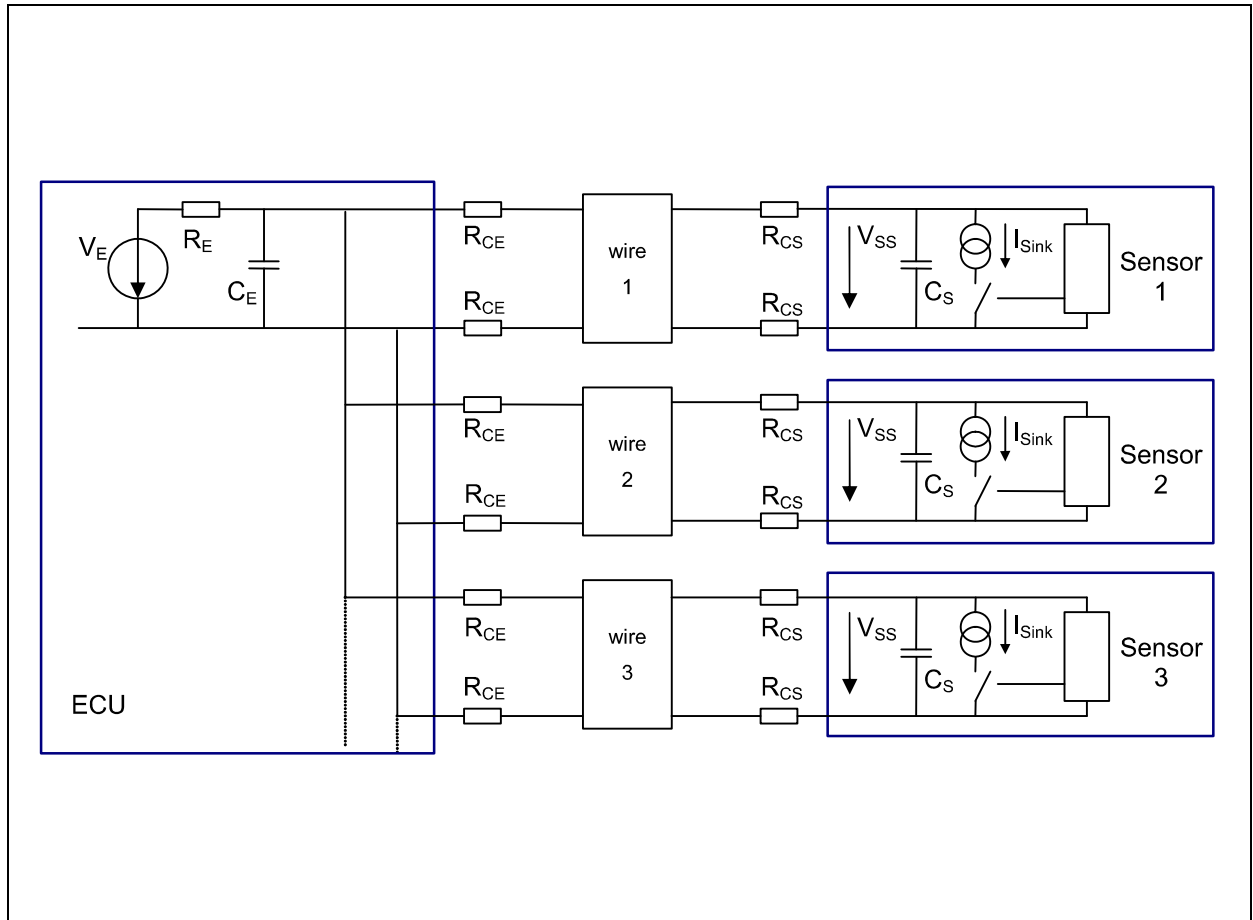

Synchronous Universal Bus Mode (PSI5-U)

PSI5-U describes a bus configuration for synchronous data transmission of one or more sensors. The sensors are connected to the ECU in different wiring topologies including splices or pass-through configurations. Each data transmission period is initiated by a voltage synchronization signal from the ECU to the sensors. Having received the synchronization signal, each sensor starts transmitting its data with the corresponding time shift in the assigned time slot.

Figure 70:
Synchronous Parallel Bus Mode (PSI5-P)

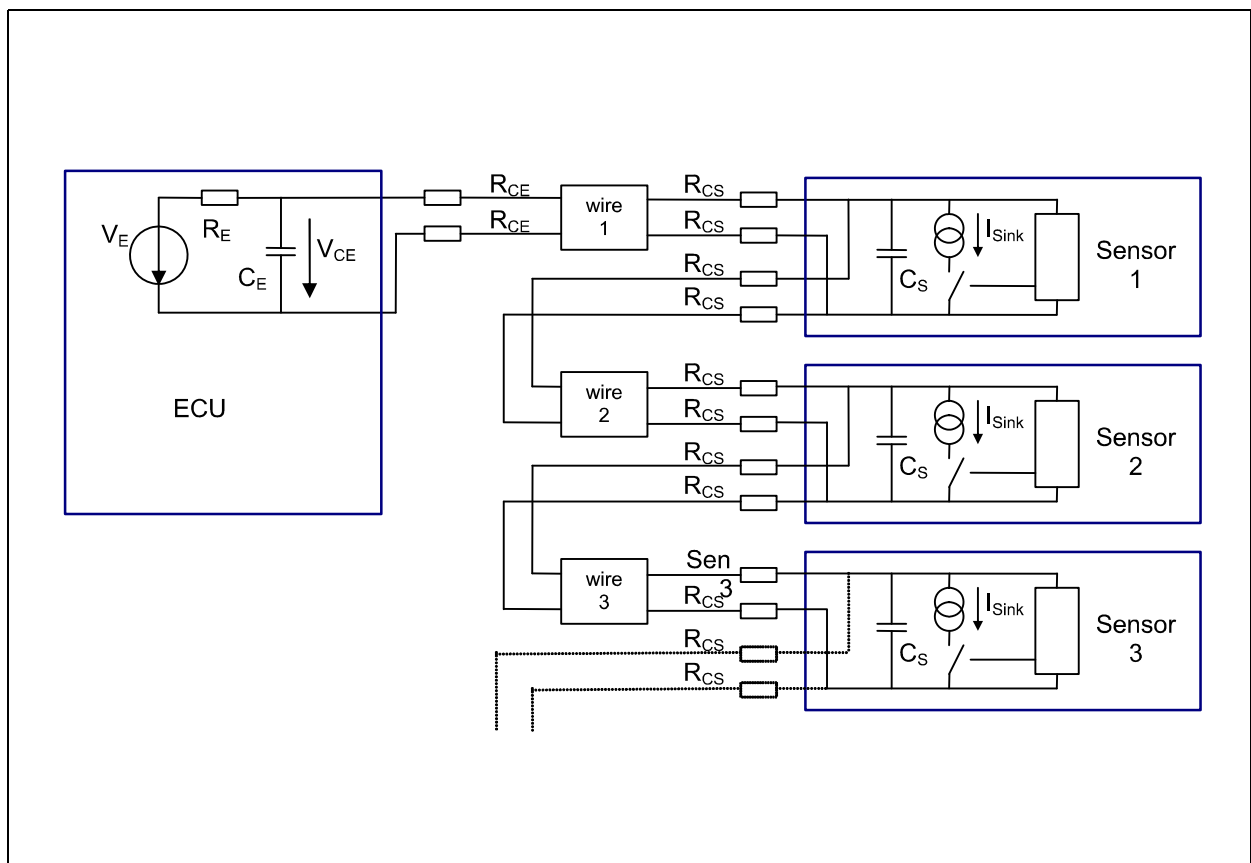

Diagnostic

The AS5172 allows a high ASIL level in the application through a robust embedded self-diagnostic. (e.g. ASIL A)

In general, AS5172 sensor is developed as SEooC according to the ISO26262. For more information refer to the AS5172 Safety Manual which is available on request to the application engineering team.

Figure 71:
Diagnostic Table

SM	Failure Mode	Recoverable	10-Bit Mode Error Info	16-Bit Mode Error Info	20-Bit Mode Error Info
SM1	Watchdog fail	-	Permanent low level	Permanent low level	Permanent low level
SM2	Offset compensation	X	0x1ED	0x1ED at A9 to A0 E0 = 1	0x1ED at A15 to A6 E0 = 1
SM3	CORDIC overflow	-	0x1F4	0x1F4 at A9 to A0 E0 = 1	0x1F4 at A15 to A6 E0 = 1 A0 = 1
SM4	Magnetic field out of range	X	0x1EB	0x1EB at A9 to A0 E0 = 1	0x1EB at A15 to A6 E0 = 1
SM5	VDD3V3 undervoltage	X	Permanent low level	Permanent low level	Permanent low level
SM6	Reverse polarity	X	Permanent low level	Permanent low level	Permanent low level
SM7	VDD overvoltage	X	0x1EA	0x1EA at A9 to A0 E0 = 1	0x1EA at A15 to A6 E0 = 1
SM8	VDD undervoltage under POR level	-	Permanent low level	Permanent low level	Permanent low level

SM	Failure Mode	Recoverable	10-Bit Mode Error Info	16-Bit Mode Error Info	20-Bit Mode Error Info
SM9	VDD undervoltage	X	0x1EC	0x1EC at A9 to A0 E0 = 1	0x1EC at A15 to A6 E0 = 1
SM10	OTP checksum error	-	0x1F4	0x1F4 at A9 to A0 E0 = 1	0x1F4 at A15 to A6 E0 = 1 A2 = 1
SM11 ⁽²⁾	Broken Hall element	-	0x1F4	0x1F4 at A9 to A0 E0 = 1	0x1F4 at A15 to A6 E0 = 1 A3 = 1

Note(s):

1. Recoverable: Sensor is working if the error condition is solved.
2. Disabled in version AS5172B. May effect ASIL level in application.

Diagnostic Procedure in PSi5

If a OTP checksum error (SM10) occurs after the first OTP download the PSi5 interface shows a “Sensor Defect” Code - 0x1F4 in initialization phase III. This error code will be sent until the device is powered off.

If any other diagnostic error condition occurs during initialization phase I or II the error will be masked. It will then be reported in initialization phase III by transmitting “Sensor Defect” Code - 0x1F4.

When a diagnostic error condition appears during PSi5 run mode the specific error code will be transmitted on the PSi5 interface.

During Run Mode:

When a diagnostic error condition appears during the PSi5 run mode the error code “Sensor Defect” (0x1F4) has to be transmitted on the PSi5 interface until the AS5172 is reset by the ECU.

The internal diagnostic error conditions are:

- CORDIC Overflow
- OTP Check fail
- Broken Hall element
- Broken channel
- Watchdog

When an watchdog error is present the PSi5_out signal from the digital part is forced to “0”. Therefore the PSi5 interface shows a permanent low level current as long as the watchdog error is present.

When an VDD3 undervoltage is present the PSI5_out signal from the digital part is forced to "0". Therefore the PSI5 interface shows a permanent low level current as long as the VDD3 undervoltage is present.

In magnet field strength out of spec, the AS5172 is transmitting the error code 0x1EB during the PSI5 run mode and keeps transmitting this error code until the flag goes to low or the AS5172 is powered off by ECU.

In overvoltage, the AS5172 is transmitting the error code 0x1EA during the PSI5 run mode and keeps transmitting this error code until the flag from the analog part goes to low or AS5172 is powered off by ECU.

In undervoltage (between threshold and min VDD), the AS5172 is transmitting the error code 0x1EC during the PSI5 run mode and keeps transmitting this error code until the flag from the analog part goes to low or AS5172 is powered off by ECU.

When an undervoltage below the POR threshold is present the PSI5_out signal from the digital part is forced to "0". Therefore the PSI5 interface shows a permanent low level current as long as the undervoltage is present.

When using the 20bit or 16Bit mode the status message "Sensor Defect" (code 0x1F4) is transmitted at the bits A15 to A6 and also the bit E0 is set to "1" when there is a diagnostic error condition. The frame control bits (F2 to F0) keep the functionality of the frame counter. On the bits A5 to A0 a detailed failure code is transmitted with the following bit assignment.

System Level EMC/ESD

AS5172A in the (SiP Package) is built to fulfill system level EMC and ESD standards.

A full certified test report is available upon request. Please get in contact with the application engineering team.

Application Information

Signature Calculation

The OTP of AS5172 uses a BIST technique with Multiple Input Signature Register circuits. To activate this BIST a calculation of the Signature Byte is necessary which has to be stored in the OTP during programming. For calculating the signature byte the content of the whole memory (0x01 to 0x1F) has to be read out. Out of this information the following calculation has to be done.

Byte: 0x01 = data1

Byte: 0x02 = data2

...

Byte: 0x1F = data31

```

unsigned int misr, misr_shift, misr_xor, misr_msb;
    misr = 0;
    for (int i = 0; i < 30; i++) {
        misr_shift = (misr << 1);
        misr_xor = (misr_shift ^ content[i]) % 256;
        misr_msb = misr / (128);
        if (misr_msb == 0)
            misr = misr_xor;
        else
            misr = (misr_xor ^ 29) % 256;
    }
content= { data1,data2,data3,data4,data5,data6,
data7,data8,data9,data10,data11,
data12,data13,data14,data15,data16,
data17,data18,data19,data20,data21,data22,
data23,data24,data25,data26,data27,data28,
data29,data30,data31};

```

Programming Procedure

For further information about the programming please refer to application note AN_AS5172_Programming_Procedure_V1-00. Please get in contact with the application engineering team.

Recommended Application Diagrams and Built-In Capacitors

AS5172B

Figure 72:
Application Schematic for AS5172B

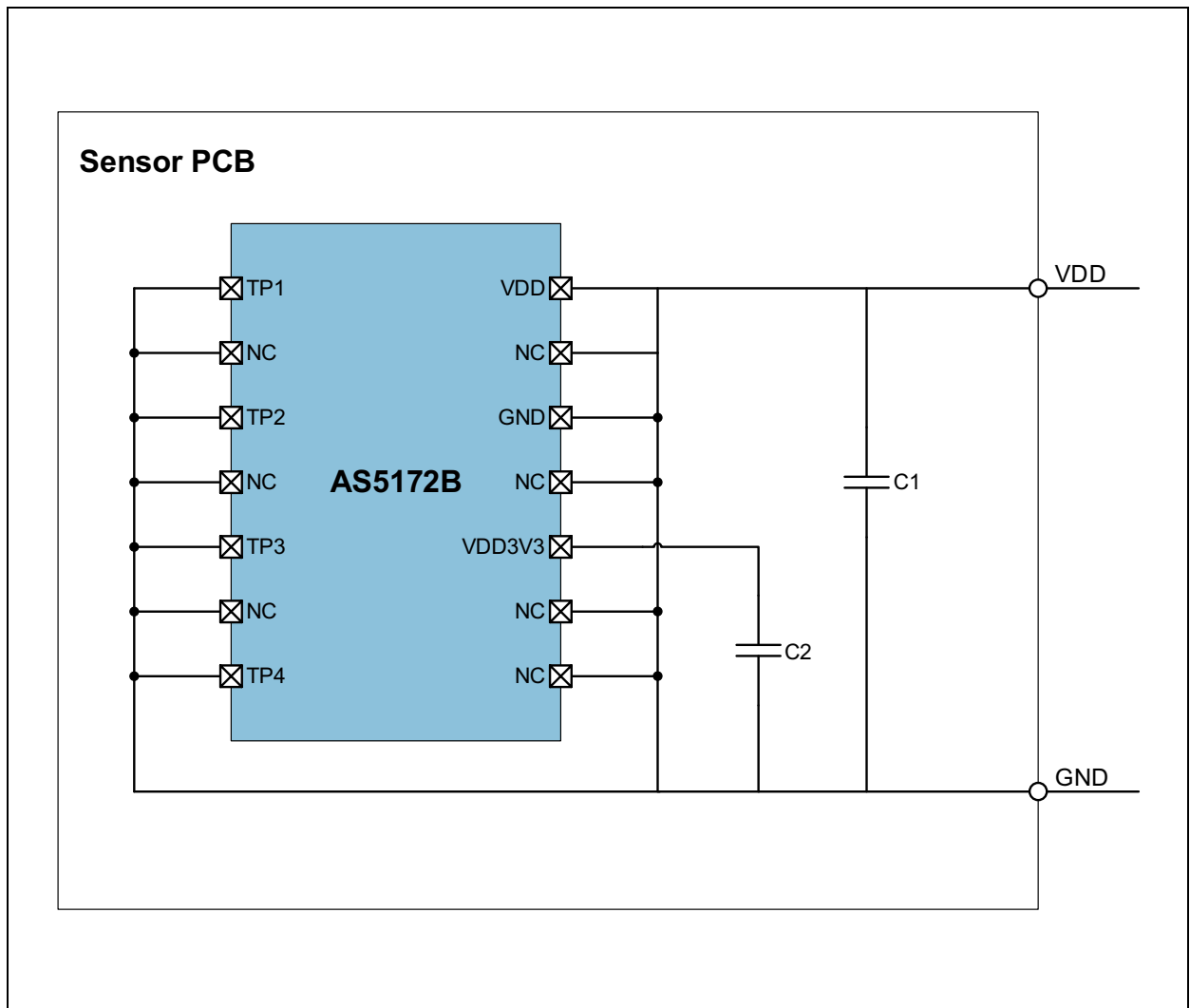

AS5172A

Figure 73:
Application Schematic for AS5172A

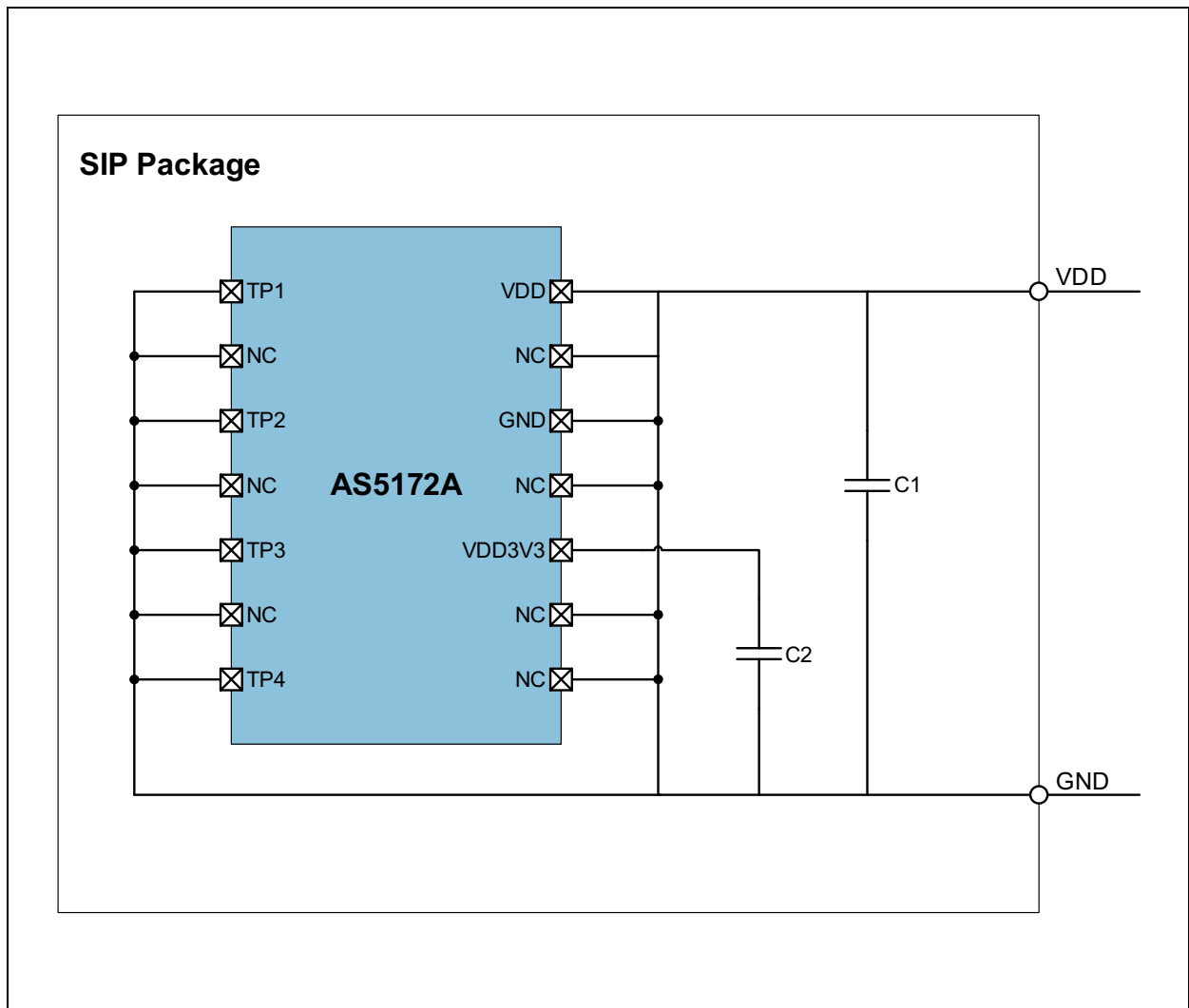
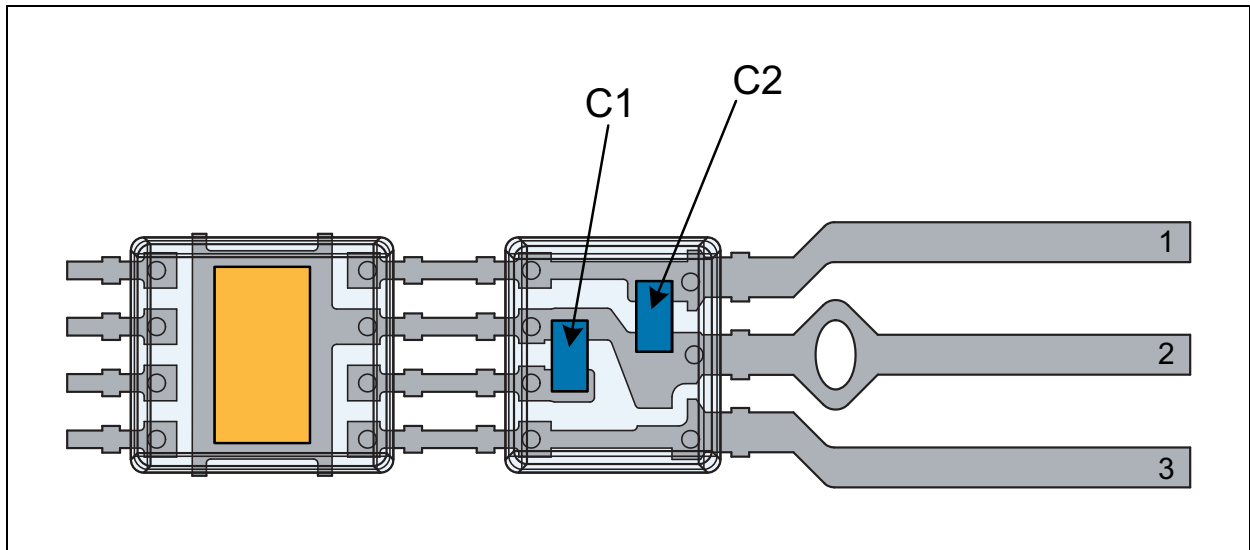

Figure 74:
AS5172A Components



The built-in capacitors are ceramic multilayer type X8R. The capacitors are built for high temperature applications up to 150°C.

Figure 75:
AS5172 Component Specification (AS5172A)

Symbol	AS5172A Components	Min	Typ	Max	Unit	Notes
C1	VDD buffer capacitor	13.5	15	16.5	nF	Included in the SIP package TDK CGA3E2X8R1H153K080AA
C2	VDD3V3 regulator capacitor		470		nF	Included in the SIP package TDK CGA3E3X8R1C474K080AB
C2_ESR	VDD3V3 regulator capacitor ESR			300	MΩ	

Figure 76:
AS5172 Component Specification (AS5172B)

Symbol	AS5172B Components	Min	Typ	Max	Unit	Notes
C1	VDD buffer capacitor	13.5	15	16.5	nF	
C2	VDD3V3 regulator capacitor		470		nF	
C2_ESR	VDD3V3 regulator capacitor ESR			300	MΩ	

Package Drawings & Markings

Figure 77:
TSSOP14 Packaging Outline Drawing

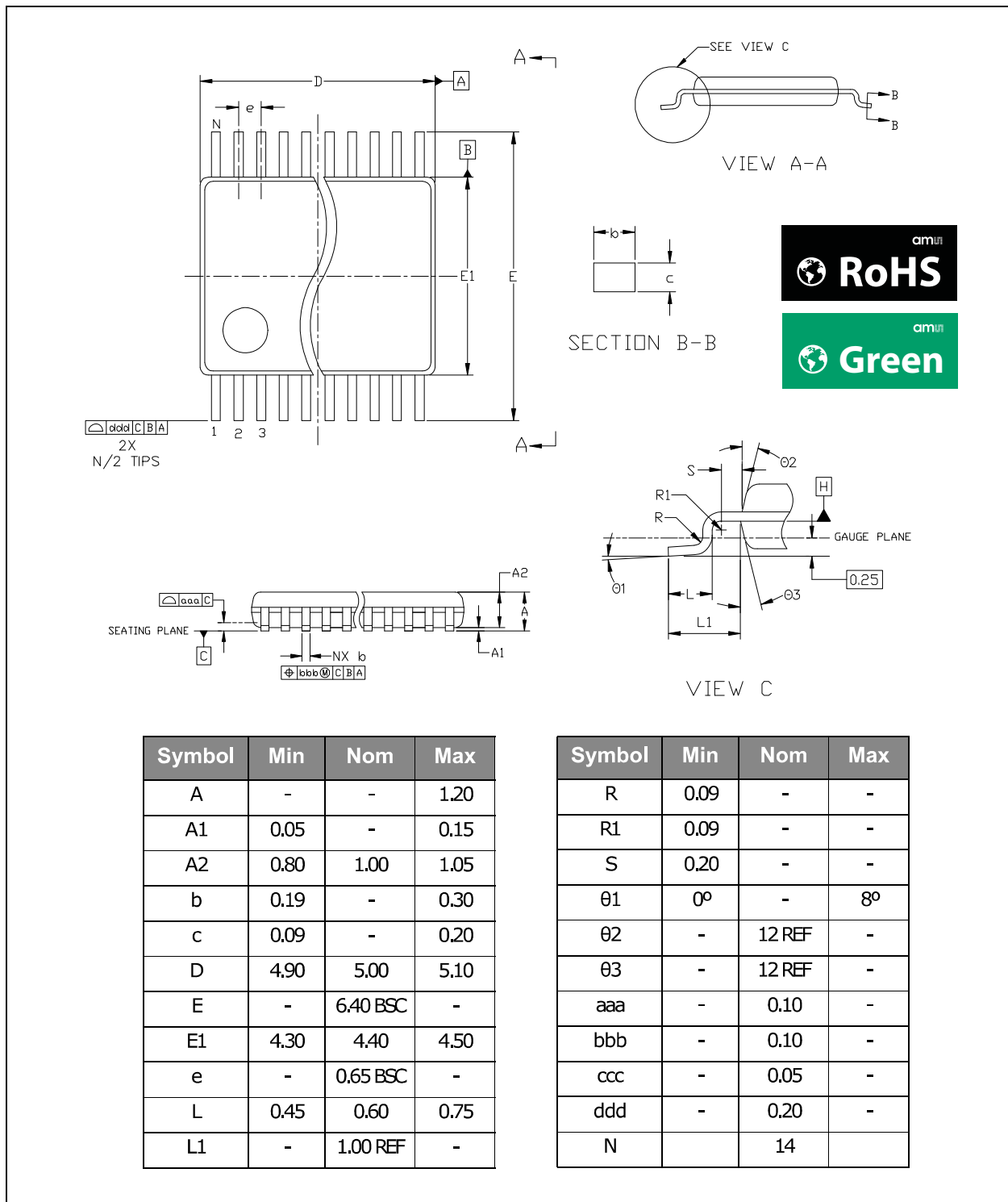

Note(s):

1. Dimensioning and tolerancing conform to ASME Y14.5M - 1994.
2. All dimensions are in millimeters. Angles are in degrees.
3. N is the total number of terminals.

Figure 78:
TSSOP14 Marking Drawings

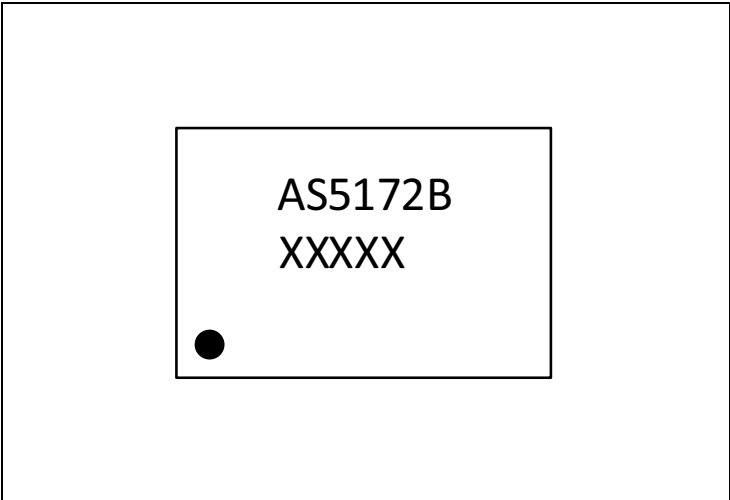
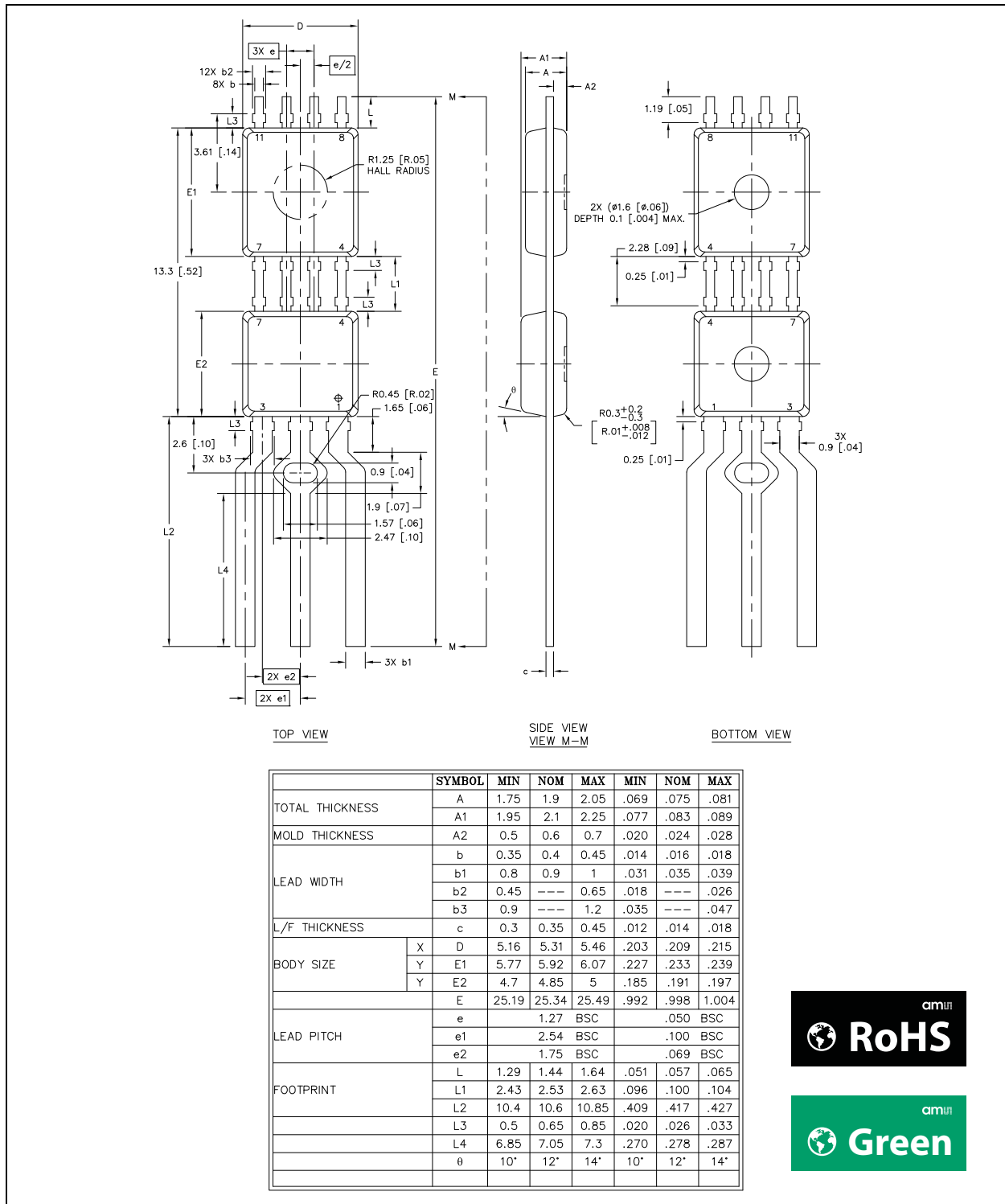

Figure 79:
TSSOP14 Packaging Code

XXXXX
Tracecode

Figure 80:
SIP Packaging Outline Drawing



Note(s):

- All linear dimensions are in millimeters, inches are indicated in brackets [in]. Angles are in degrees.
- Dimension D does not include mold flash, protrusions or gate burrs. Mold flash, protrusions or gate burrs shall not exceed 0.3mm (0.012in) per side.
- Dimension b and b1 does not include dam bar protrusion and matte tin plating.
Allowable dam bar protrusion shall be 0.3mm (0.012in) total in excess of the b, b1, b2 and b3 dimension at maximum material condition.
- Dimension E1 and E2 does not include interlead flash or protrusion. Interlead flash or protrusion shall not exceed 0.3mm (0.012in) per side.
- Dimension tolerance: ±0.15mm unless otherwise specified.

Figure 81:
SIP Marking Drawings

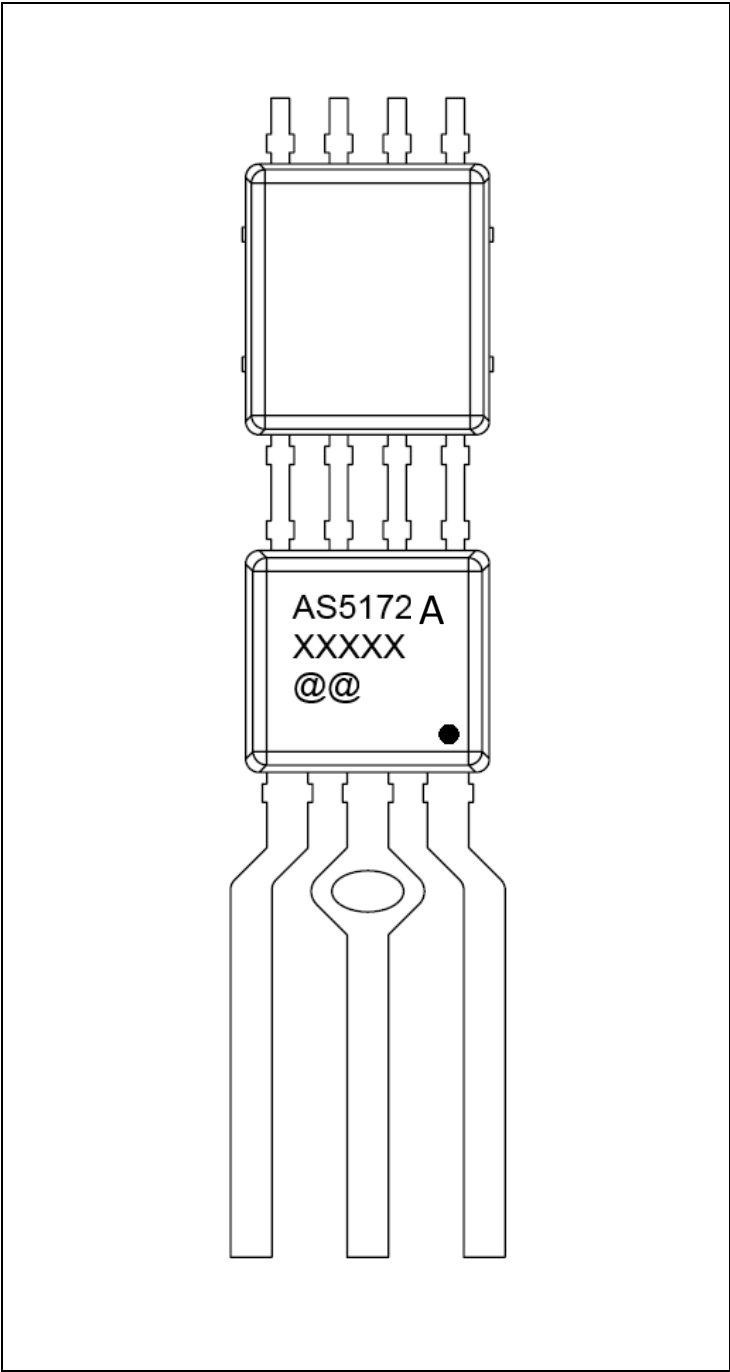
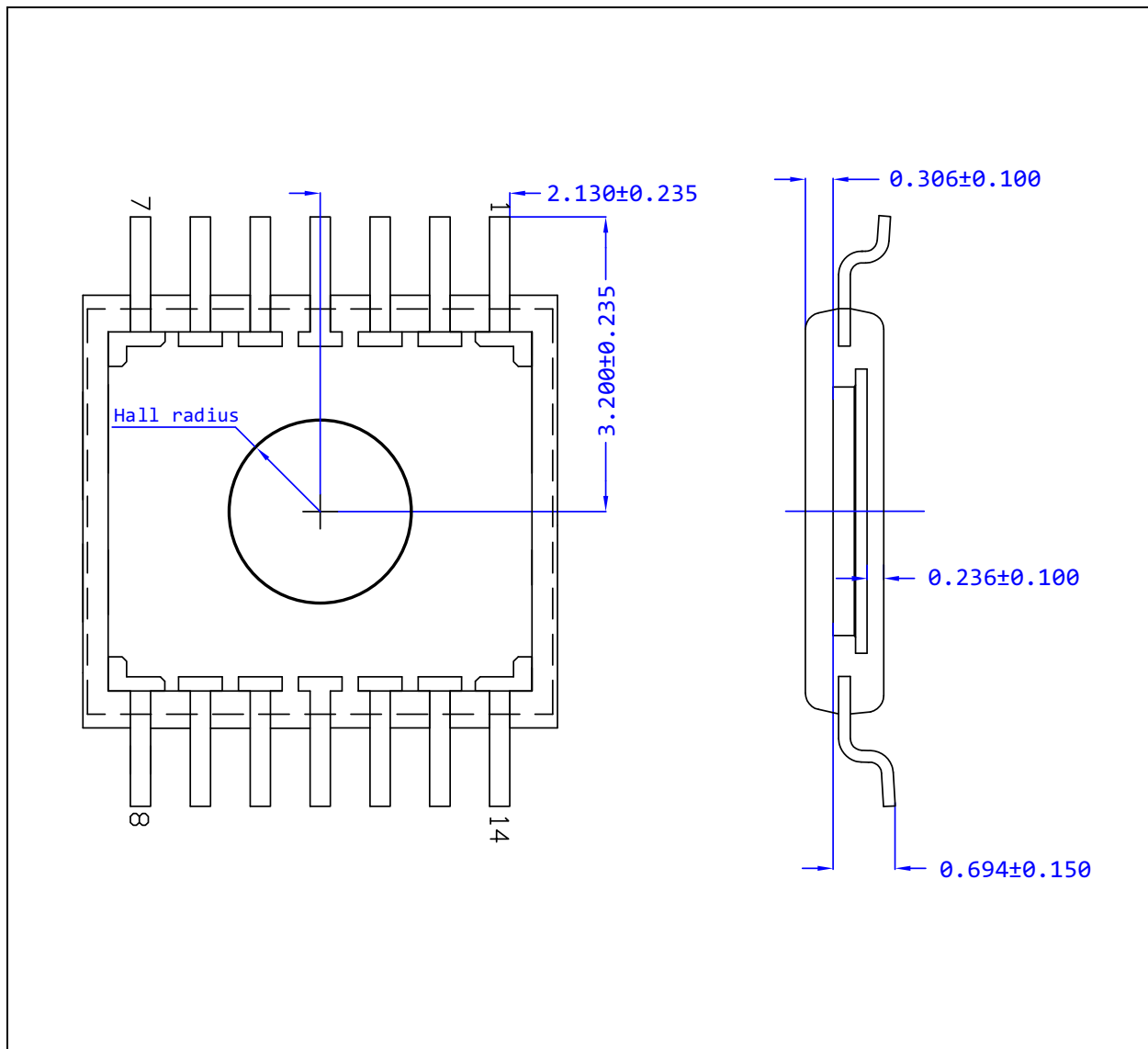

Figure 82:
SIP Packaging Code

XXXXX	@@
Tracecode	Sublot identifier

Mechanical Data

Figure 83:
TSSOP14 Die Placement and Hall Array Position



Note(s):

1. Dimensions are in mm.
2. The Hall array center is located in the center of the IC package. Hall array radius is 1.25mm.
3. Die thickness is 203 μ m nominal.

Figure 84:
SIP Die Placement and Hall Array Position

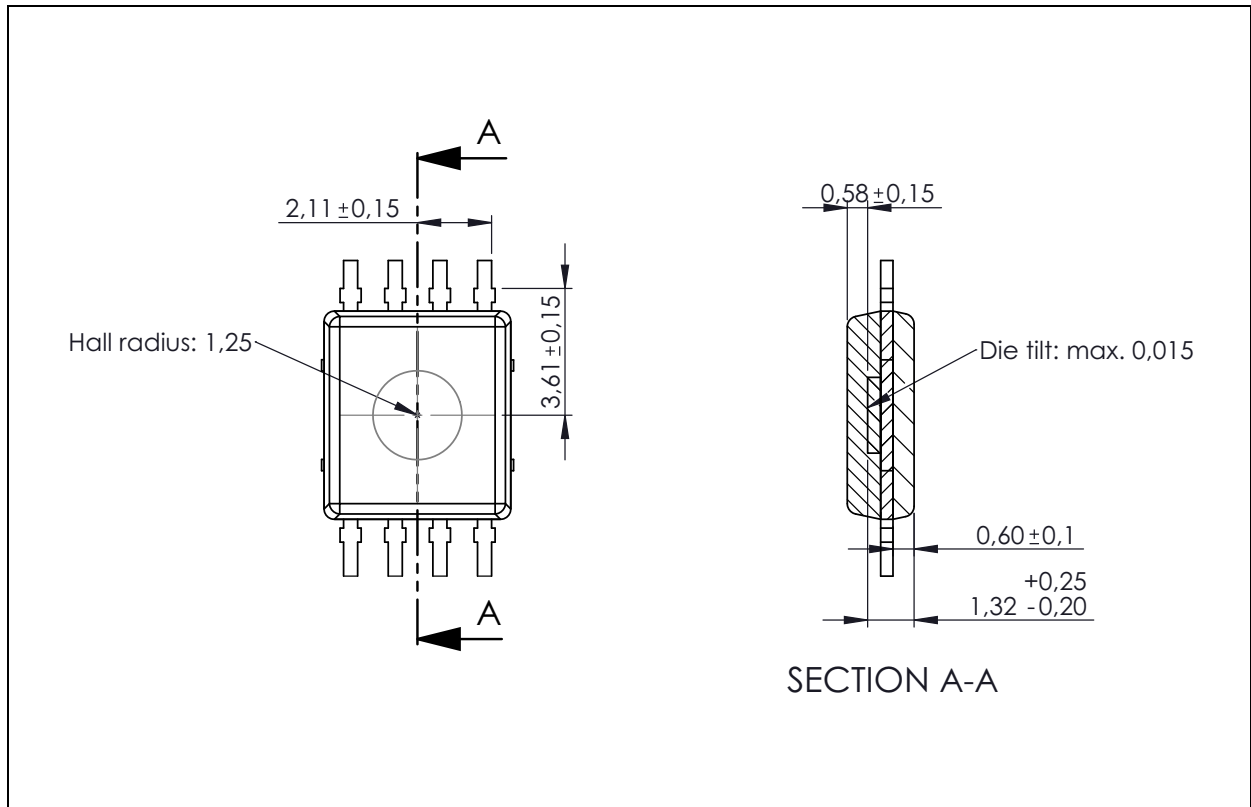

Note(s):

1. All dimensions in mm.
2. Tolerances shown represent expected values and are to be verified. Tolerances will be guaranteed prior to product release.

Mechanical Information

For information in terms of manufacturability with different processes, please refer to the following document, which is available upon request: *AN_ams_SIP Handling_V1.01.pdf*

Ordering & Contact Information

Figure 85:
Ordering Information

Ordering Code	Package	Marking	Delivery Form	Delivery Quantity
AS5172B-HTST ⁽¹⁾	TSSOP-14	AS5172B	13" Tape & Reel in dry pack	4500 pcs/reel
AS5172B-HTSM ⁽¹⁾	TSSOP-14	AS5172B	7" Tape & Reel in dry pack	500 pcs/reel
AS5172A-ASIP	SIP	AS5172A	13" Tape & Reel in dry pack	2000 pcs/reel

Note(s):

1. Safety function SM11 is disabled in version AS5172B.

Buy our products or get free samples online at:
www.ams.com/Products

Technical Support is available at:
www.ams.com/Technical-Support

Provide feedback about this document at:
www.ams.com/Document-Feedback

For further information and requests, e-mail us at:
ams_sales@ams.com

For sales offices, distributors and representatives, please visit:
www.ams.com/Contact

Headquarters

ams AG
Tobelbader Strasse 30
8141 Premstaetten
Austria, Europe

Tel: +43 (0) 3136 500 0

Website: www.ams.com

RoHS Compliant & ams Green Statement

RoHS: The term RoHS compliant means that ams AG products fully comply with current RoHS directives. Our semiconductor products do not contain any chemicals for all 6 substance categories, including the requirement that lead not exceed 0.1% by weight in homogeneous materials. Where designed to be soldered at high temperatures, RoHS compliant products are suitable for use in specified lead-free processes.

ams Green (RoHS compliant and no Sb/Br): ams Green defines that in addition to RoHS compliance, our products are free of Bromine (Br) and Antimony (Sb) based flame retardants (Br or Sb do not exceed 0.1% by weight in homogeneous material).

Important Information: The information provided in this statement represents ams AG knowledge and belief as of the date that it is provided. ams AG bases its knowledge and belief on information provided by third parties, and makes no representation or warranty as to the accuracy of such information. Efforts are underway to better integrate information from third parties. ams AG has taken and continues to take reasonable steps to provide representative and accurate information but may not have conducted destructive testing or chemical analysis on incoming materials and chemicals. ams AG and ams AG suppliers consider certain information to be proprietary, and thus CAS numbers and other limited information may not be available for release.

Copyrights & Disclaimer

Copyright ams AG, Tobelbader Strasse 30, 8141 Premstaetten, Austria-Europe. Trademarks Registered. All rights reserved. The material herein may not be reproduced, adapted, merged, translated, stored, or used without the prior written consent of the copyright owner.

Devices sold by ams AG are covered by the warranty and patent indemnification provisions appearing in its General Terms of Trade. ams AG makes no warranty, express, statutory, implied, or by description regarding the information set forth herein. ams AG reserves the right to change specifications and prices at any time and without notice. Therefore, prior to designing this product into a system, it is necessary to check with ams AG for current information. This product is intended for use in commercial applications. Applications requiring extended temperature range, unusual environmental requirements, or high reliability applications, such as military, medical life-support or life-sustaining equipment are specifically not recommended without additional processing by ams AG for each application. This product is provided by ams AG "AS IS" and any express or implied warranties, including, but not limited to the implied warranties of merchantability and fitness for a particular purpose are disclaimed.

ams AG shall not be liable to recipient or any third party for any damages, including but not limited to personal injury, property damage, loss of profits, loss of use, interruption of business or indirect, special, incidental or consequential damages, of any kind, in connection with or arising out of the furnishing, performance or use of the technical data herein. No obligation or liability to recipient or any third party shall arise or flow out of ams AG rendering of technical or other services.

Document Status

Document Status	Product Status	Definition
Product Preview	Pre-Development	Information in this datasheet is based on product ideas in the planning phase of development. All specifications are design goals without any warranty and are subject to change without notice
Preliminary Datasheet	Pre-Production	Information in this datasheet is based on products in the design, validation or qualification phase of development. The performance and parameters shown in this document are preliminary without any warranty and are subject to change without notice
Datasheet	Production	Information in this datasheet is based on products in ramp-up to full production or full production which conform to specifications in accordance with the terms of ams AG standard warranty as given in the General Terms of Trade
Datasheet (discontinued)	Discontinued	Information in this datasheet is based on products which conform to specifications in accordance with the terms of ams AG standard warranty as given in the General Terms of Trade, but these products have been superseded and should not be used for new designs

Revision Information

Changes from 1-04 (2018-Jun-21) to current revision 1-05 (2018-Jul-05)	Page
Updated Figure 25	31
Renamed Figure 52 as "Synchronous Mode P10P-500/3L"	50
Renamed Figure 53 as "Timing Parameters of P10P-500/3L"	51
Named Figure 54 as "Synchronous Mode P10P-500/3L with Discharge Pulse"	52
Named Figure 55 as "Timing Parameters of P10P-500/3L with Discharge Pulse"	53
Renamed Figure 56 as "Asynchronous Modes A10P- 50/1L and A10P-500/1L"	54
Renamed Figure 57 as "Timing Parameters of A10P- 50/1L and A10P-500/1L"	54
Renamed Figure 58 as "Timing Parameters of Synchronous Modes P20CRC-500/1L, P20CRC-500/2L, P20CRC-500/2H, P20CRC-500/3H"	55
Renamed Figure 59 as "Distinct Timing Parameters of P16CRC-500/3H"	57
Renamed Figure 60 as "Asynchronous Modes A20CRC-200/1H and A20CRC-300/1L"	58
Renamed Figure 61 as "Timing Parameters of A20CRC-200/1H and A20CRC-300/1L"	58
Updated text under "Initialization Data Content"	62

Note(s):

1. Page and figure numbers for the previous version may differ from page and figure numbers in the current revision.
2. Correction of typographical errors is not explicitly mentioned.

Content Guide

1	General Description
2	Key Benefits and Features
2	Applications
3	Block Diagram
4	Pin Assignments
4	Pin Diagram
7	Absolute Maximum Ratings
8	System Electrical and Timing Characteristics
10	Electrical System Characteristics
12	Magnetic Characteristics
13	Electrical and Timing Characterization of the PSI5 Interface
13	Synchronization Signal PSI5 V1.3
16	Synchronization Signal Detection
18	Synchronization Signal with Discharge by AS5172
21	PSI5 Block Parameters
23	Detailed Description
24	Register Description
24	OTP (non-volatile memory) Register Description
29	Volatile Memory Register Description
29	SFR Description
30	Programming
30	UART-Over-PSI5
32	UART Protocol
33	Reading of the 14-Bit Angle Information
33	Reading the Magnitude and AGC
33	Exiting the Communication Mode
34	Burn the OTP Registers
34	AS5172 Transfer Function
36	Multiple Quadrants
37	Extended Magnetic Input Range
37	Rolling Counter
38	Angular Velocity Measurement
39	Special Functions
39	14-Bit Mode
39	Quadrant Detection
39	Extended PSI5 Initialization Phase
40	PSI5 Interface
40	Bit Encoding - AS5172 to ECU Communication
41	Data Frames - AS5172 to ECU Communication
41	Data Ranges
48	PSI5 Modes
50	PSI5 Timing
59	PSI5 Initialization
63	Communication Modes
66	Diagnostic
68	System Level EMC/ESD

69 Application Information

69 Signature Calculation

70 Programming Procedure

70 Recommended Application Diagrams and Built-In Capacitors

70 AS5172B

71 AS5172A

73 Package Drawings & Markings

77 Mechanical Data

78 Mechanical Information

79 Ordering & Contact Information

80 RoHS Compliant & ams Green Statement

81 Copyrights & Disclaimer

82 Document Status

83 Revision Information

Компания «Океан Электроники» предлагает заключение долгосрочных отношений при поставках импортных электронных компонентов на взаимовыгодных условиях!

Наши преимущества:

- Поставка оригинальных импортных электронных компонентов напрямую с производств Америки, Европы и Азии, а так же с крупнейших складов мира;
- Широкая линейка поставок активных и пассивных импортных электронных компонентов (более 30 млн. наименований);
- Поставка сложных, дефицитных, либо снятых с производства позиций;
- Оперативные сроки поставки под заказ (от 5 рабочих дней);
- Экспресс доставка в любую точку России;
- Помощь Конструкторского Отдела и консультации квалифицированных инженеров;
- Техническая поддержка проекта, помощь в подборе аналогов, поставка прототипов;
- Поставка электронных компонентов под контролем ВП;
- Система менеджмента качества сертифицирована по Международному стандарту ISO 9001;
- При необходимости вся продукция военного и аэрокосмического назначения проходит испытания и сертификацию в лаборатории (по согласованию с заказчиком);
- Поставка специализированных компонентов военного и аэрокосмического уровня качества (Xilinx, Altera, Analog Devices, Intersil, Interpoint, Microsemi, Actel, Aeroflex, Peregrine, VPT, Syfer, Eurofarad, Texas Instruments, MS Kennedy, Miteq, Cobham, E2V, MA-COM, Hittite, Mini-Circuits, General Dynamics и др.);

Компания «Океан Электроники» является официальным дистрибьютором и эксклюзивным представителем в России одного из крупнейших производителей разъемов военного и аэрокосмического назначения «JONHON», а так же официальным дистрибьютором и эксклюзивным представителем в России производителя высокотехнологичных и надежных решений для передачи СВЧ сигналов «FORSTAR».



JONHON

«JONHON» (основан в 1970 г.)

Разъемы специального, военного и аэрокосмического назначения:

(Применяются в военной, авиационной, аэрокосмической, морской, железнодорожной, горно- и нефтедобывающей отраслях промышленности)

«FORSTAR» (основан в 1998 г.)

ВЧ соединители, коаксиальные кабели,
кабельные сборки и микроволновые компоненты:

(Применяются в телекоммуникациях гражданского и специального назначения, в средствах связи, РЛС, а так же военной, авиационной и аэрокосмической отраслях промышленности).



Телефон: 8 (812) 309-75-97 (многоканальный)

Факс: 8 (812) 320-03-32

Электронная почта: ocean@oceanchips.ru

Web: <http://oceanchips.ru/>

Адрес: 198099, г. Санкт-Петербург, ул. Калинина, д. 2, корп. 4, лит. А