

## Features

- 3.3 V operation (3.0 V–3.6 V)
- High speed
  - $t_{AA} = 15$  ns
- CMOS for optimum speed/power
- Low Active Power
  - 576 mW (max)
- Low CMOS Standby Power
  - 1.80 mW (max)
- Automatic power-down when deselected
- Independent control of upper and lower bits
- Available in 44-pin TSOP II and 48-ball Mini BGA package

## Functional Description

The CY7C1021BNV33<sup>[1]</sup> is a high-performance CMOS static RAM organized as 65,536 words by 16 bits. This device has an automatic power-down feature that significantly reduces power consumption when deselected.

Writing to the device is accomplished by taking Chip Enable ( $\overline{CE}$ ) and Write Enable (WE) inputs LOW. If Byte Low Enable (BLE) is LOW, then data from I/O pins (I/O<sub>0</sub> through I/O<sub>7</sub>), is written into the location specified on the address pins (A<sub>0</sub> through A<sub>15</sub>). If Byte High Enable (BHE) is LOW, then data from I/O pins (I/O<sub>8</sub> through I/O<sub>15</sub>) is written into the location specified on the address pins (A<sub>0</sub> through A<sub>15</sub>).

Reading from the device is accomplished by taking Chip Enable ( $\overline{CE}$ ) and Output Enable ( $\overline{OE}$ ) LOW while forcing the Write Enable (WE) HIGH. If Byte Low Enable (BLE) is LOW, then data from the memory location specified by the address pins will appear on I/O<sub>0</sub> to I/O<sub>7</sub>. If Byte High Enable (BHE) is LOW, then data from memory will appear on I/O<sub>8</sub> to I/O<sub>15</sub>. See the truth table at the back of this data sheet for a complete description of read and write modes.

The input/output pins (I/O<sub>0</sub> through I/O<sub>15</sub>) are placed in a high-impedance state when the device is deselected ( $\overline{CE}$  HIGH), the outputs are disabled ( $\overline{OE}$  HIGH), the BHE and BLE are disabled (BHE, BLE HIGH), or during a write operation ( $\overline{CE}$  LOW, and WE LOW).

The CY7C1021BNV33 is available in standard 44-pin TSOP Type II and 48-ball mini BGA packages.

For a complete list of related documentation, click [here](#).

### Note

1. For guidelines on SRAM system design, please refer to the 'System Design Guidelines' Cypress application note, available on the internet at [www.cypress.com](http://www.cypress.com).

### Logic Block Diagram

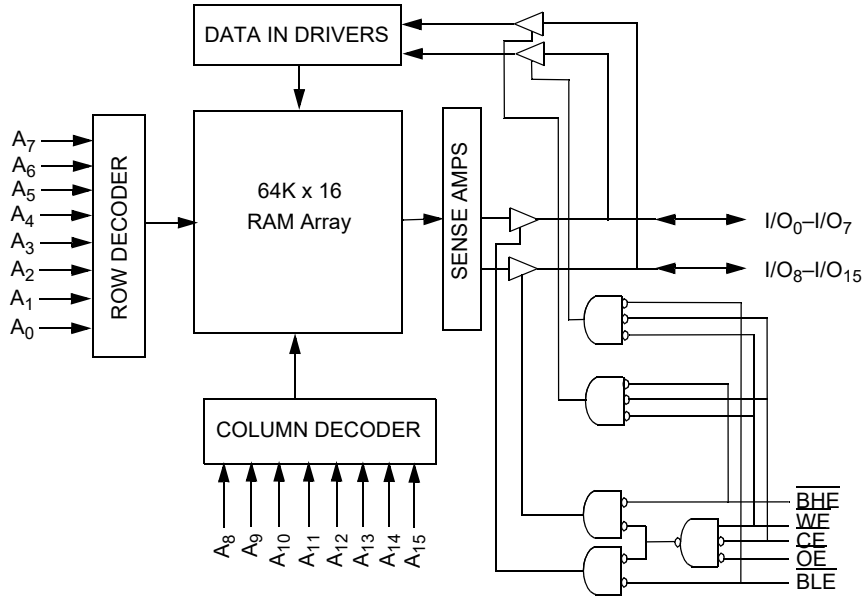

### Selection Guide

	<b>-15</b>
Maximum Access Time (ns)	15
Maximum Operating Current (mA)	160
Maximum CMOS Standby Current (mA)	0.5

## Contents

<b>Pin Configurations</b> .....	<b>4</b>	<b>Package Diagrams</b> .....	<b>13</b>
<b>Maximum Ratings</b> .....	<b>5</b>	<b>Acronyms</b> .....	<b>15</b>
<b>Operating Range</b> .....	<b>5</b>	<b>Document Conventions</b> .....	<b>15</b>
<b>Electrical Characteristics</b> .....	<b>5</b>	Units of Measure .....	15
<b>Capacitance</b> .....	<b>5</b>	<b>Document History Page</b> .....	<b>16</b>
<b>AC Test Loads and Waveforms</b> .....	<b>5</b>	<b>Sales, Solutions, and Legal Information</b> .....	<b>17</b>
<b>Data Retention Characteristics</b> .....	<b>6</b>	Worldwide Sales and Design Support .....	17
<b>Data Retention Waveform</b> .....	<b>6</b>	Products .....	17
<b>Switching Characteristics</b> .....	<b>7</b>	PSoC® Solutions .....	17
<b>Switching Waveforms</b> .....	<b>8</b>	Cypress Developer Community .....	17
<b>Truth Table</b> .....	<b>11</b>	Technical Support .....	17
<b>Ordering Information</b> .....	<b>12</b>		
Ordering Code Definitions .....	12		

## Pin Configurations

Figure 1. 44-pin TSOP Type II pinout

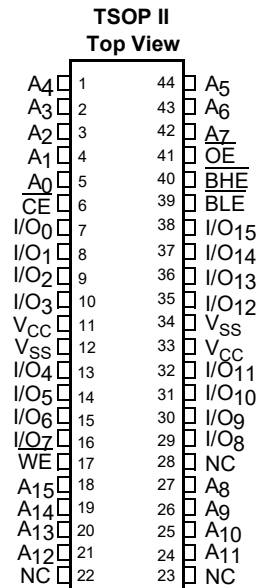
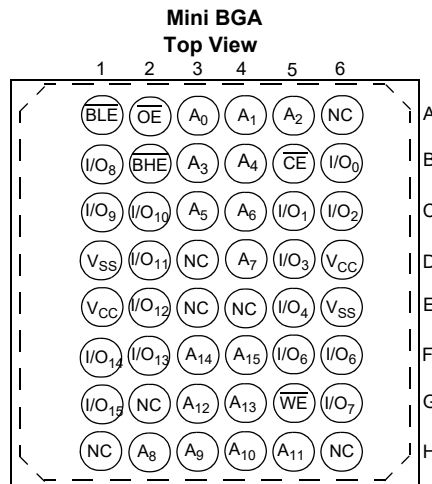

Figure 2. 48-ball mini BGA pinout



## Maximum Ratings

Exceeding maximum ratings may shorten the useful life of the device. User guidelines are not tested.

Storage Temperature .....	-65 °C to +150 °C
Ambient Temperature with Power Applied .....	-55 °C to +125 °C
Supply Voltage on $V_{CC}$ to Relative GND [2] .....	-0.5 V to +4.6 V
DC Voltage Applied to Outputs in High Z State [2] .....	-0.5 V to $V_{CC} + 0.5$ V

DC Input Voltage [2] .....	-0.5 V to $V_{CC} + 0.5$ V
Current into Outputs (LOW) .....	20 mA
Static Discharge Voltage (per MIL-STD-883, Method 3015) .....	> 2001 V
Latch-Up Current .....	> 200 mA

## Operating Range

Range	Ambient Temperature	$V_{CC}$
Industrial	-40 °C to +85 °C	3.3 V $\pm$ 10%

## Electrical Characteristics

Over the Operating Range

Parameter	Description	Test Conditions	-15		Unit
			Min	Max	
$V_{OH}$	Output HIGH Voltage	$V_{CC} = \text{Min}, I_{OH} = -4.0$ mA	2.4	-	V
$V_{OL}$	Output LOW Voltage	$V_{CC} = \text{Min}, I_{OL} = 8.0$ mA	-	0.4	V
$V_{IH}$	Input HIGH Voltage		2.2	$V_{CC} + 0.3$	V
$V_{IL}$	Input LOW Voltage [2]		-0.3	0.8	V
$I_{IX}$	Input Load Current	$GND \leq V_I \leq V_{CC}$	-1	+1	$\mu$ A
$I_{OZ}$	Output Leakage Current	$GND \leq V_I \leq V_{CC}$ , Output Disabled	-1	+1	$\mu$ A
$I_{CC}$	$V_{CC}$ Operating Supply Current	$V_{CC} = \text{Max}, I_{OUT} = 0$ mA, $f = f_{MAX} = 1/t_{RC}$	-	160	mA
$I_{SB1}$	Automatic CE Power Down Current – TTL Inputs	Max $V_{CC}$ , $\overline{CE} \geq V_{IH}$ , $V_{IN} \geq V_{IH}$ or $V_{IN} \leq V_{IL}$ , $f = f_{MAX}$	-	40	mA
$I_{SB2}$	Automatic CE Power Down Current – CMOS Inputs	Max $V_{CC}$ , $\overline{CE} \geq V_{CC} - 0.3$ V, $V_{IN} \geq V_{CC} - 0.3$ V or $V_{IN} \leq 0.3$ V, $f = 0$	-	500	$\mu$ A

## Capacitance

Parameter [3]	Description	Test Conditions	Max	Unit
$C_{IN}$	Input capacitance	$T_A = 25$ °C, $f = 1$ MHz	6	pF
$C_{OUT}$	Output capacitance		8	pF

## AC Test Loads and Waveforms

Figure 3. AC Test Loads and Waveforms

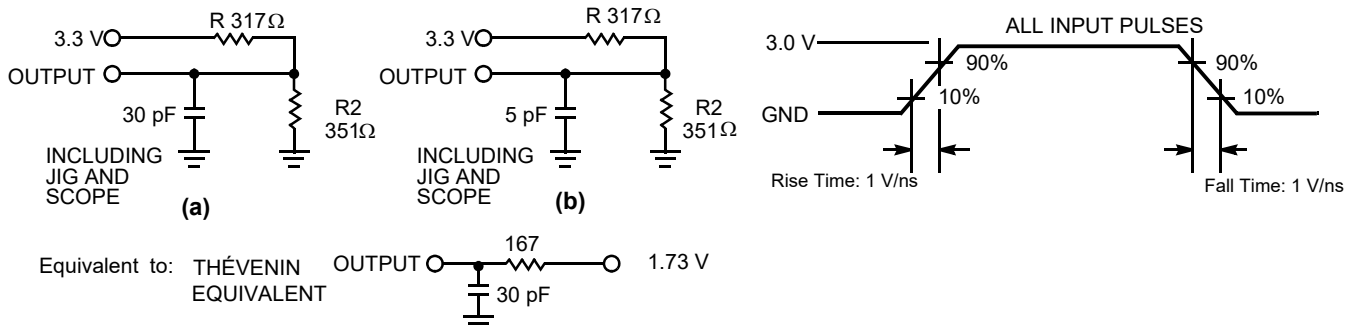

### Notes

- Minimum voltage is -2.0 V for pulse durations of less than 20 ns.
- Tested initially and after any design or process changes that may affect these parameters.

## Data Retention Characteristics

Over the Operating Range (L version only)

Parameter	Description	Conditions <sup>[4]</sup>	Min	Max	Unit
$V_{DR}$	$V_{CC}$ for Data Retention		2.0	–	V
$I_{CCDR}$	Data Retention Current	$V_{CC} = V_{DR} = 2.0\text{ V}$ , $\overline{CE} \geq V_{CC} - 0.3\text{ V}$ , $V_{IN} \geq V_{CC} - 0.3\text{ V}$ or $V_{IN} \leq 0.3\text{ V}$	–	100	$\mu\text{A}$
$t_{CDR}^{[5]}$	Chip Deselect to Data Retention Time		0	–	ns
$t_R^{[6]}$	Operation Recovery Time		15	–	ns

## Data Retention Waveform

Figure 4. Data Retention Waveform

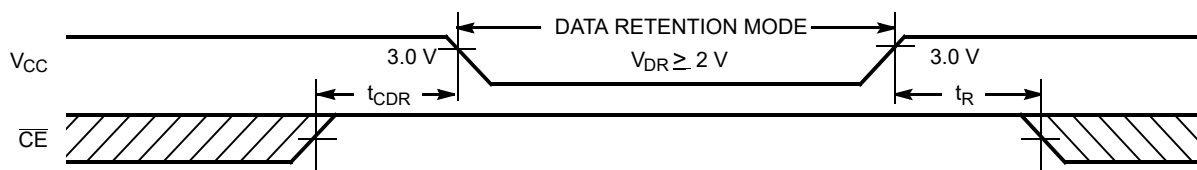

### Notes

4. No input may exceed  $V_{CC} + 0.5\text{ V}$ .
5. Tested initially and after any design or process changes that may affect these parameters.
6.  $t_r \leq 3\text{ ns}$  for the -12 and -15 speeds.  $t_r \leq 5\text{ ns}$  for the -20 and slower speeds.

## Switching Characteristics

Over the Operating Range

Parameter <sup>[7]</sup>	Description	-15		Unit
		Min	Max	
<b>READ CYCLE</b>				
$t_{RC}$	Read Cycle Time	15	–	ns
$t_{AA}$	Address to Data Valid	–	15	ns
$t_{OHA}$	Data Hold from Address Change	3	–	ns
$t_{ACE}$	$\overline{CE}$ LOW to Data Valid	–	15	ns
$t_{DOE}$	$\overline{OE}$ LOW to Data Valid	–	7	ns
$t_{LZOE}$	$\overline{OE}$ LOW to Low Z	0	–	ns
$t_{HZOE}$	$\overline{OE}$ HIGH to High Z <sup>[8, 9]</sup>	–	7	ns
$t_{LZCE}$	$\overline{CE}$ LOW to Low Z <sup>[9]</sup>	3	–	ns
$t_{HZCE}$	$\overline{CE}$ HIGH to High Z <sup>[8, 9]</sup>	–	7	ns
$t_{PU}$	$\overline{CE}$ LOW to Power-Up	0	–	ns
$t_{PD}$	$\overline{CE}$ HIGH to Power-Down	–	15	ns
$t_{DBE}$	Byte Enable to Data Valid	–	7	ns
$t_{LZBE}$	Byte Enable to Low Z	0	–	ns
$t_{HZBE}$	Byte Disable to High Z	–	7	ns
<b>WRITE CYCLE</b> <sup>[10, 11]</sup>				
$t_{WC}$	Write Cycle Time	15	–	ns
$t_{SCE}$	$\overline{CE}$ LOW to Write End	10	–	ns
$t_{AW}$	Address Set-Up to Write End	10	–	ns
$t_{HA}$	Address Hold from Write End	0	–	ns
$t_{SA}$	Address Set-Up to Write Start	0	–	ns
$t_{PWE}$	$\overline{WE}$ Pulse Width	10	–	ns
$t_{SD}$	Data Set-Up to Write End	8	–	ns
$t_{HD}$	Data Hold from Write End	0	–	ns
$t_{LZWE}$	$\overline{WE}$ HIGH to Low Z <sup>[9]</sup>	3	–	ns
$t_{HZWE}$	$\overline{WE}$ LOW to High Z <sup>[8, 9]</sup>	–	7	ns
$t_{BW}$	Byte Enable to End of Write	9	–	ns

### Notes

- Test conditions assume signal transition time of 3 ns or less, timing reference levels of 1.5 V, input pulse levels of 0 to 3.0 V, and output loading of the specified  $I_{OL}/I_{OH}$  and 30-pF load capacitance.
- $t_{HZOE}$ ,  $t_{HZBE}$ ,  $t_{HZCE}$ , and  $t_{HZWE}$  are specified with a load capacitance of 5 pF as in part (b) of [Figure 3 on page 5](#). Transition is measured  $\pm 500$  mV from steady-state voltage.
- At any given temperature and voltage condition,  $t_{HZCE}$  is less than  $t_{LZCE}$ ,  $t_{HZOE}$  is less than  $t_{LZOE}$ , and  $t_{HZWE}$  is less than  $t_{LZWE}$  for any given device.
- The internal write time of the memory is defined by the overlap of  $\overline{CE}$  LOW,  $\overline{WE}$  LOW and  $\overline{BHE}/\overline{BLE}$  LOW.  $\overline{CE}$ ,  $\overline{WE}$  and  $\overline{BHE}/\overline{BLE}$  must be LOW to initiate a write, and LOW to HIGH transition on any of these signals can terminate the write. The input data set-up and hold timing should be referenced to the leading edge of the signal that terminates the write.
- The minimum write cycle time for Write Cycle No. 3 ( $\overline{WE}$  Controlled,  $\overline{OE}$  LOW) should be equal to the sum of  $t_{SD}$  and  $t_{HZWE}$ .

### Switching Waveforms

Figure 5. Read Cycle No. 1 [12, 13]

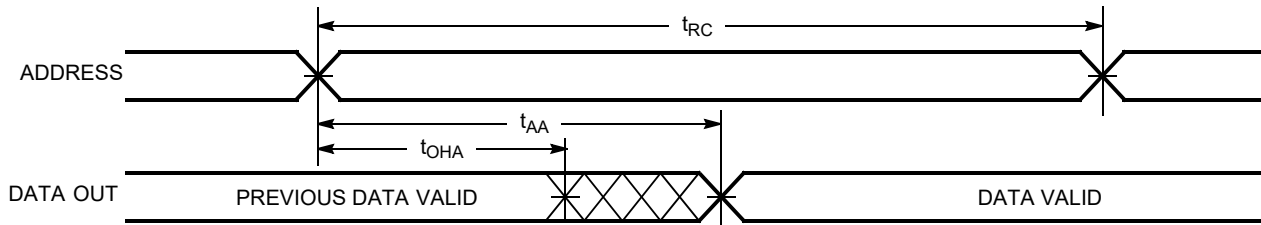
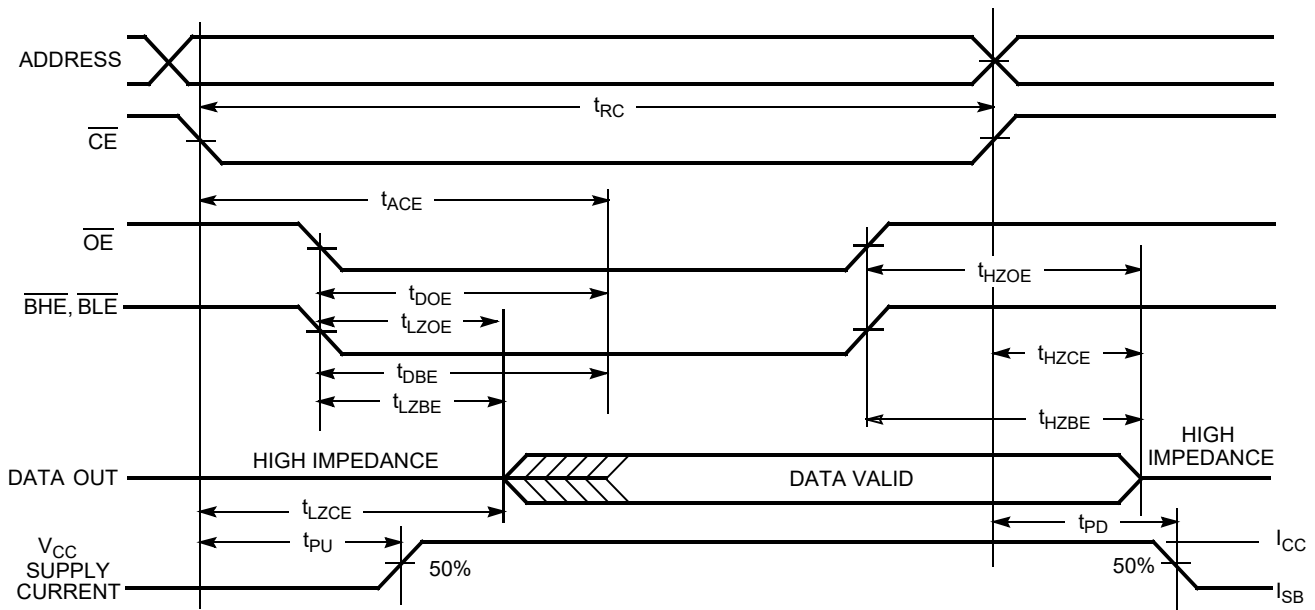

Figure 6. Read Cycle No. 2 ( $\overline{OE}$  Controlled) [13, 14]



**Notes**

- 12. Device is continuously selected.  $\overline{OE}$ ,  $\overline{CE}$ ,  $\overline{BHE}$  and/or  $\overline{BHE} = V_{IL}$ .
- 13.  $\overline{WE}$  is HIGH for read cycle.
- 14. Address valid prior to or coincident with  $\overline{CE}$  transition LOW.



Switching Waveforms(continued)

Figure 7. Write Cycle No. 1 ( $\overline{\text{CE}}$  Controlled) [15, 16, 17]

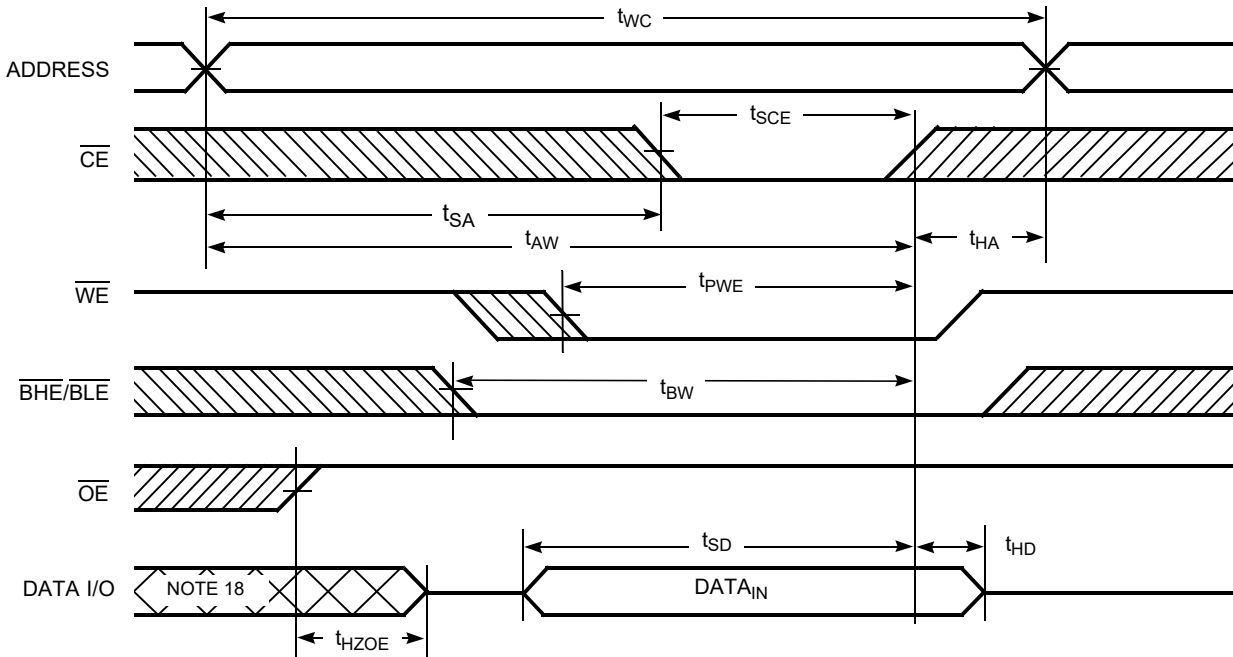
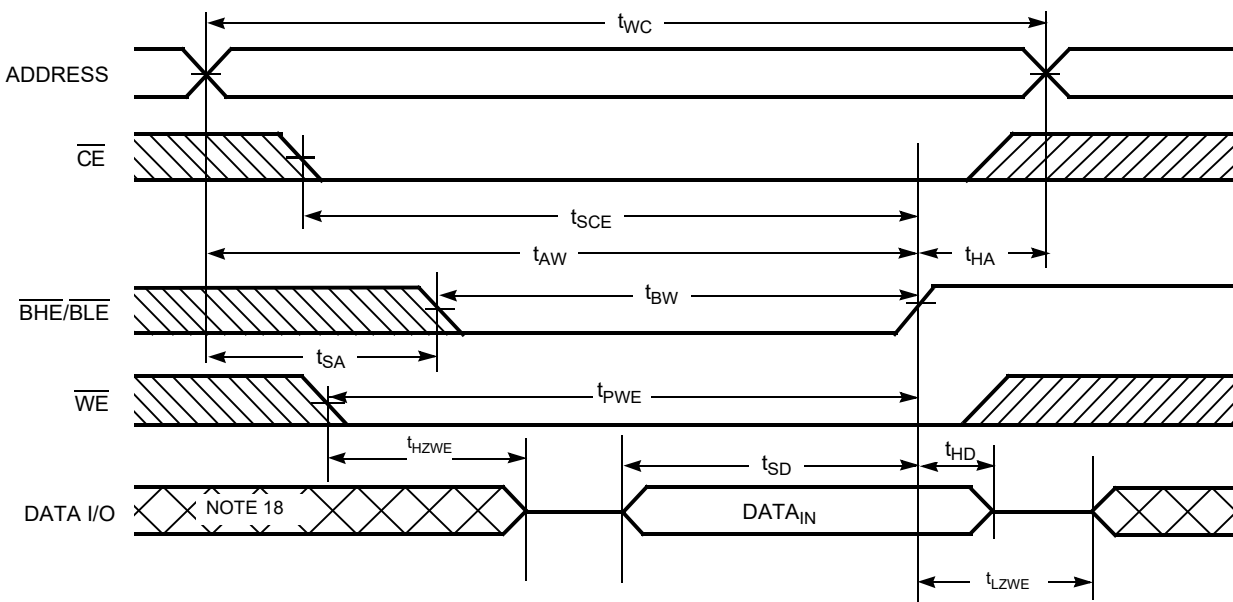

Figure 8. Write Cycle No. 2 ( $\overline{\text{BLE}}$  or  $\overline{\text{BHE}}$  Controlled) [15, 16, 17]



Notes

15. The internal write time of the memory is defined by the overlap of  $\overline{\text{WE}}$ ,  $\overline{\text{CE}} = V_{\text{IL}}$ ,  $\overline{\text{BHE}}$ ,  $\overline{\text{BLE}}$ , or both =  $V_{\text{IL}}$ . All signals must be active to initiate a write and any of these signals can terminate a write by going inactive. The data input setup and hold timing must be referenced to the edge of the signal that terminates the write.
16. Data I/O is high impedance if  $\overline{\text{OE}}$  or  $\overline{\text{BHE}}$  and/or  $\overline{\text{BLE}} = V_{\text{IH}}$ .
17. If  $\overline{\text{CE}}$  goes HIGH simultaneously with  $\overline{\text{WE}}$  going HIGH, the output remains in a high-impedance state.
18. During this period, the I/Os are in output state. Do not apply input signals.

Switching Waveforms(continued)

Figure 9. Write Cycle No. 3 ( $\overline{WE}$  Controlled,  $\overline{OE}$  LOW) [19, 20, 21]

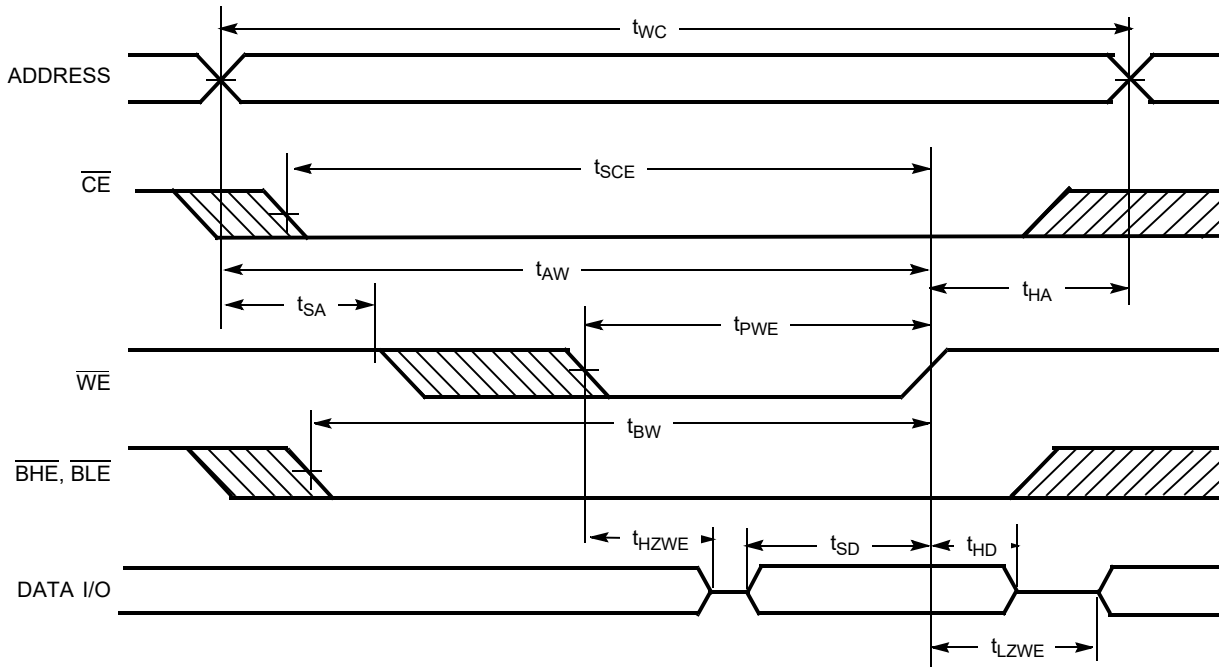

Notes

19. The internal write time of the memory is defined by the overlap of  $\overline{WE}$ ,  $\overline{CE} = V_{IL}$ ,  $\overline{BHE}$ ,  $\overline{BLE}$ , or both =  $V_{IL}$ . All signals must be active to initiate a write and any of these signals can terminate a write by going inactive. The data input setup and hold timing must be referenced to the edge of the signal that terminates the write.
20. If  $\overline{CE}$  goes HIGH simultaneously with  $\overline{WE}$  going HIGH, the output remains in a high-impedance state.
21. The minimum write cycle pulse width should be equal to the sum of  $t_{SD}$  and  $t_{HZWE}$ .

**Truth Table**

$\overline{CE}$	$\overline{OE}$	$\overline{WE}$	$\overline{BLE}$	$\overline{BHE}$	I/O <sub>0</sub> -I/O <sub>7</sub>	I/O <sub>8</sub> -I/O <sub>15</sub>	Mode	Power
H	X	X	X	X	High Z	High Z	Power-Down	Standby (I <sub>SB</sub> )
L	L	H	L	L	Data Out	Data Out	Read - All bits	Active (I <sub>CC</sub> )
			L	H	Data Out	High Z	Read - Lower bits only	Active (I <sub>CC</sub> )
			H	L	High Z	Data Out	Read - Upper bits only	Active (I <sub>CC</sub> )
L	X	L	L	L	Data In	Data In	Write - All bits	Active (I <sub>CC</sub> )
			L	H	Data In	High Z	Write - Lower bits only	Active (I <sub>CC</sub> )
			H	L	High Z	Data In	Write - Upper bits only	Active (I <sub>CC</sub> )
L	H	H	X	X	High Z	High Z	Selected, Outputs Disabled	Active (I <sub>CC</sub> )
L	X	X	H	H	High Z	High Z	Selected, Outputs Disabled	Active (I <sub>CC</sub> )

## Ordering Information

Cypress offers other versions of this type of product in many different configurations and features. The following table contains only the list of parts that are currently available. For a complete listing of all options, visit the Cypress website at <http://www.cypress.com> and refer to the product summary page at <http://www.cypress.com/products> or contact your local sales representative.

Cypress maintains a worldwide network of offices, solution centers, manufacturer’s representatives and distributors. To find the office closest to you, visit us at <http://www.cypress.com/go/datasheet/offices>.

Speed (ns)	Ordering Code	Package Diagram	Package Type	Operating Range
15	CY7C1021BNV33L-15BAI	51-85096	48-ball Mini BGA (7 mm × 7 mm)	Industrial
	CY7C1021BNV33L-15BAIT	51-85096	48-ball Mini BGA (7 mm × 7 mm) Tape and Reel	
	CY7C1021BNV33L-15ZXI	51-85087	44-pin TSOP Type II (Pb-free)	
	CY7C1021BNV33L-15ZXIT	51-85087	44-pin TSOP Type II (Pb-free) Tape and Reel	

Please contact local sales representative regarding availability of these parts.

## Ordering Code Definitions

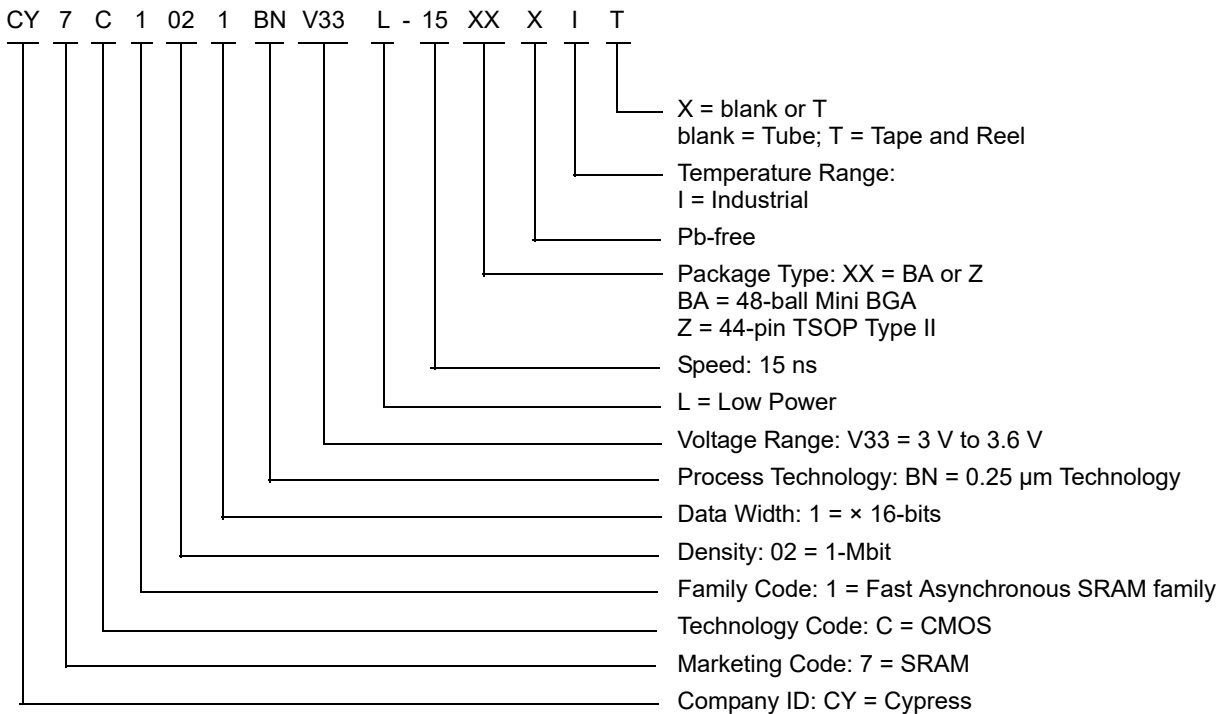

Package Diagrams

Figure 10. 48-ball FBGA (7 mm × 7 mm × 1.2 mm) BA48 Package Outline, 51-85096

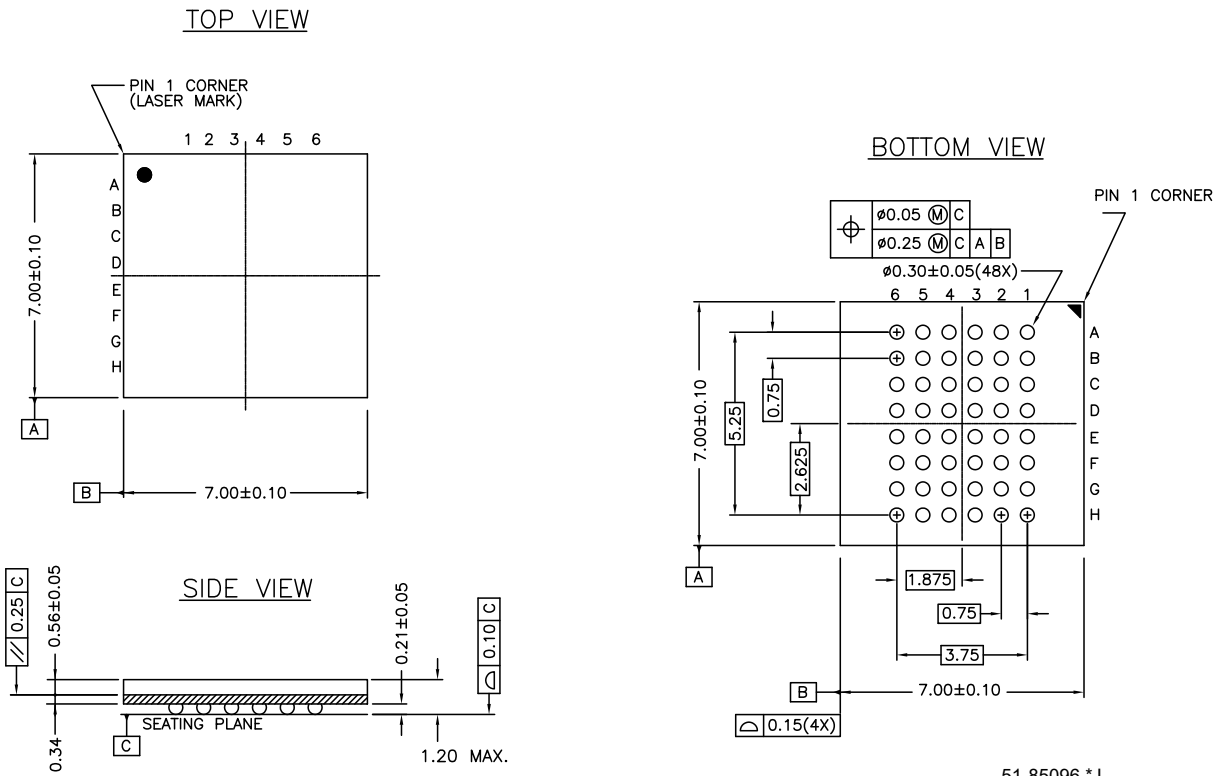

51-85096 \*J

Package Diagrams(continued)

Figure 11. 44-pin TSOP Z44-II Package Outline, 51-85087

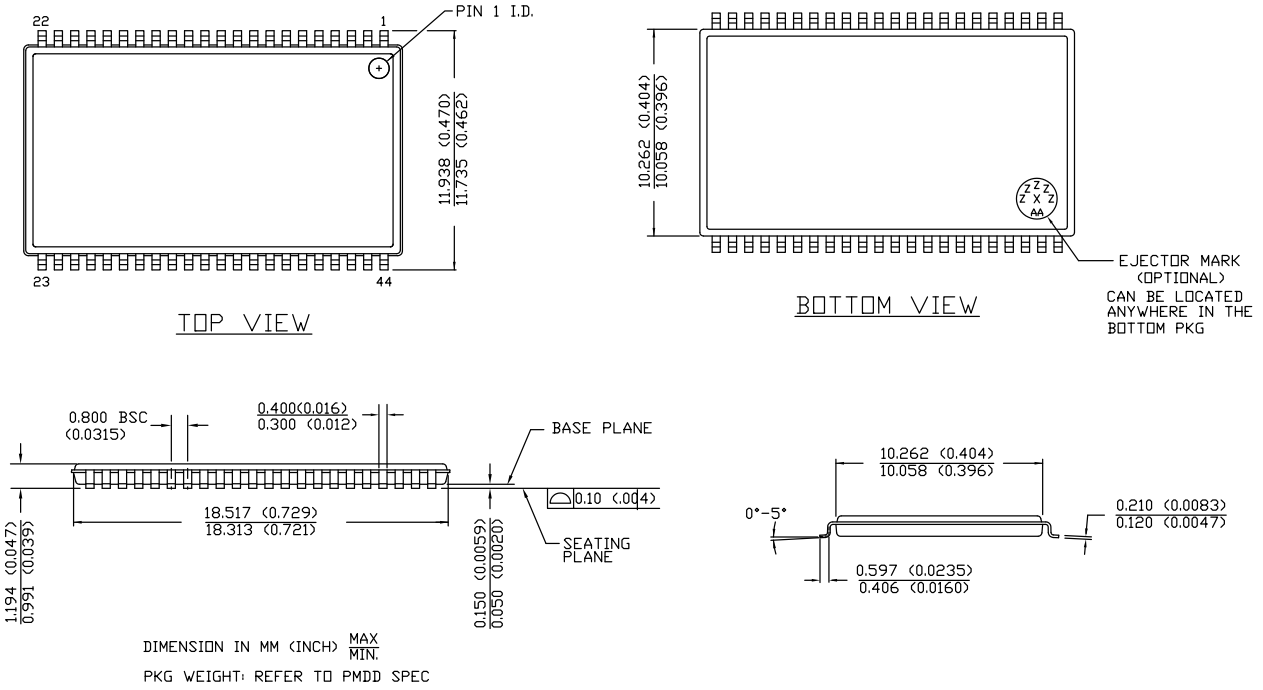

51-85087 \*E

## Acronyms

Acronym	Description
BGA	Ball Grid Array
$\overline{CE}$	Chip Enable
CMOS	Complementary Metal Oxide Semiconductor
FBGA	Fine-pitch Ball Grid Array
I/O	Input/Output
$\overline{OE}$	Output Enable
SRAM	Static Random Access Memory
TSOP	Thin Small-Outline Package
TTL	Transistor-Transistor Logic
$\overline{WE}$	Write Enable

## Document Conventions

### Units of Measure

Symbol	Unit of Measure
°C	degree Celsius
MHz	megahertz
μA	microampere
μs	microsecond
mA	milliampere
mm	millimeter
mW	milliwatt
ns	nanosecond
Ω	ohm
%	percent
pF	picofarad
V	volt
W	watt

**Document History Page**

Document Title: CY7C1021BNV33, 64K × 16 Static RAM				
Document Number: 001-06433				
Rev.	ECN No.	Orig. of Change	Submission Date	Description of Change
**	423847	NXR	02/02/2006	New data sheet.
*A	2897061	AJU	03/22/2010	Updated <a href="#">Ordering Information</a> : Updated part numbers. Updated <a href="#">Package Diagrams</a> : spec 51-85096 – Changed revision from *F to *H. spec 51-85082 – Changed revision from *B to *C. spec 51-85087 – Changed revision from *A to *C.
*B	3109897	AJU	12/14/2010	Added <a href="#">Ordering Code Definitions</a> under <a href="#">Ordering Information</a> .
*C	3103073	PRAS	03/08/2011	Updated <a href="#">Package Diagrams</a> : spec 51-85096 – Changed revision from *H to *I. Added <a href="#">Acronyms</a> and <a href="#">Units of Measure</a> . Updated to new template.
*D	3403051	AJU	10/12/2011	Updated <a href="#">Ordering Information</a> : Updated part numbers. Updated <a href="#">Package Diagrams</a> : spec 51-85082 – Changed revision from *C to *D spec 51-85087 – Changed revision from *C to *D.
*E	3937949	MEMJ	03/19/2013	Removed all references of 400-mil SOJ package in the document. Updated <a href="#">Switching Characteristics</a> : Updated Note 10. Updated <a href="#">Switching Waveforms</a> : Updated <a href="#">Figure 7</a> , <a href="#">Figure 8</a> . Added Note 15, 18 and referred the same notes in <a href="#">Figure 7</a> , <a href="#">Figure 8</a> . Referred Note 16, 17 in <a href="#">Figure 8</a> . Referred Note 19, 20 in <a href="#">Figure 9</a> . Updated <a href="#">Package Diagrams</a> : spec 51-85087 – Changed revision from *D to *E.
*F	4578447	MEMJ	01/16/2015	Updated <a href="#">Functional Description</a> : Added “For a complete list of related documentation, click <a href="#">here</a> .” at the end. Updated <a href="#">Switching Characteristics</a> : Added Note 11 and referred the same note in “WRITE CYCLE”. Updated <a href="#">Switching Waveforms</a> : Added Note 21 and referred the same note in <a href="#">Figure 9</a> . Updated <a href="#">Package Diagrams</a> : spec 51-85096 – Changed revision from *I to *J.
*G	5989860	NILE	12/13/2017	Updated <a href="#">Ordering Information</a> : Updated part numbers. Updated to new template.



## Sales, Solutions, and Legal Information

### Worldwide Sales and Design Support

Cypress maintains a worldwide network of offices, solution centers, manufacturer's representatives, and distributors. To find the office closest to you, visit us at [Cypress Locations](#).

#### Products

ARM <sup>®</sup> Cortex <sup>®</sup> Microcontrollers	<a href="http://cypress.com/arm">cypress.com/arm</a>
Automotive	<a href="http://cypress.com/automotive">cypress.com/automotive</a>
Clocks & Buffers	<a href="http://cypress.com/clocks">cypress.com/clocks</a>
Interface	<a href="http://cypress.com/interface">cypress.com/interface</a>
Internet of Things	<a href="http://cypress.com/iot">cypress.com/iot</a>
Memory	<a href="http://cypress.com/memory">cypress.com/memory</a>
Microcontrollers	<a href="http://cypress.com/mcu">cypress.com/mcu</a>
PSoC	<a href="http://cypress.com/psoc">cypress.com/psoc</a>
Power Management ICs	<a href="http://cypress.com/pmic">cypress.com/pmic</a>
Touch Sensing	<a href="http://cypress.com/touch">cypress.com/touch</a>
USB Controllers	<a href="http://cypress.com/usb">cypress.com/usb</a>
Wireless Connectivity	<a href="http://cypress.com/wireless">cypress.com/wireless</a>

#### PSoC<sup>®</sup> Solutions

[PSoC 1](#) | [PSoC 3](#) | [PSoC 4](#) | [PSoC 5LP](#) | [PSoC 6](#)

#### Cypress Developer Community

[Forums](#) | [WICED IOT Forums](#) | [Projects](#) | [Video](#) | [Blogs](#) | [Training](#) | [Components](#)

#### Technical Support

[cypress.com/support](http://cypress.com/support)

© Cypress Semiconductor Corporation, 2006–2017. This document is the property of Cypress Semiconductor Corporation and its subsidiaries, including Spansion LLC ("Cypress"). This document, including any software or firmware included or referenced in this document ("Software"), is owned by Cypress under the intellectual property laws and treaties of the United States and other countries worldwide. Cypress reserves all rights under such laws and treaties and does not, except as specifically stated in this paragraph, grant any license under its patents, copyrights, trademarks, or other intellectual property rights. If the Software is not accompanied by a license agreement and you do not otherwise have a written agreement with Cypress governing the use of the Software, then Cypress hereby grants you a personal, non-exclusive, nontransferable license (without the right to sublicense) (1) under its copyright rights in the Software (a) for Software provided in source code form, to modify and reproduce the Software solely for use with Cypress hardware products, only internally within your organization, and (b) to distribute the Software in binary code form externally to end users (either directly or indirectly through resellers and distributors), solely for use on Cypress hardware product units, and (2) under those claims of Cypress's patents that are infringed by the Software (as provided by Cypress, unmodified) to make, use, distribute, and import the Software solely for use with Cypress hardware products. Any other use, reproduction, modification, translation, or compilation of the Software is prohibited.

TO THE EXTENT PERMITTED BY APPLICABLE LAW, CYPRESS MAKES NO WARRANTY OF ANY KIND, EXPRESS OR IMPLIED, WITH REGARD TO THIS DOCUMENT OR ANY SOFTWARE OR ACCOMPANYING HARDWARE, INCLUDING, BUT NOT LIMITED TO, THE IMPLIED WARRANTIES OF MERCHANTABILITY AND FITNESS FOR A PARTICULAR PURPOSE. To the extent permitted by applicable law, Cypress reserves the right to make changes to this document without further notice. Cypress does not assume any liability arising out of the application or use of any product or circuit described in this document. Any information provided in this document, including any sample design information or programming code, is provided only for reference purposes. It is the responsibility of the user of this document to properly design, program, and test the functionality and safety of any application made of this information and any resulting product. Cypress products are not designed, intended, or authorized for use as critical components in systems designed or intended for the operation of weapons, weapons systems, nuclear installations, life-support devices or systems, other medical devices or systems (including resuscitation equipment and surgical implants), pollution control or hazardous substances management, or other uses where the failure of the device or system could cause personal injury, death, or property damage ("Unintended Uses"). A critical component is any component of a device or system whose failure to perform can be reasonably expected to cause the failure of the device or system, or to affect its safety or effectiveness. Cypress is not liable, in whole or in part, and you shall and hereby do release Cypress from any claim, damage, or other liability arising from or related to all Unintended Uses of Cypress products. You shall indemnify and hold Cypress harmless from and against all claims, costs, damages, and other liabilities, including claims for personal injury or death, arising from or related to any Unintended Uses of Cypress products.

Cypress, the Cypress logo, Spansion, the Spansion logo, and combinations thereof, WICED, PSoC, CapSense, EZ-USB, F-RAM, and Traveo are trademarks or registered trademarks of Cypress in the United States and other countries. For a more complete list of Cypress trademarks, visit [cypress.com](http://cypress.com). Other names and brands may be claimed as property of their respective owners.

Компания «Океан Электроники» предлагает заключение долгосрочных отношений при поставках импортных электронных компонентов на взаимовыгодных условиях!

Наши преимущества:

- Поставка оригинальных импортных электронных компонентов напрямую с производств Америки, Европы и Азии, а так же с крупнейших складов мира;
- Широкая линейка поставок активных и пассивных импортных электронных компонентов (более 30 млн. наименований);
- Поставка сложных, дефицитных, либо снятых с производства позиций;
- Оперативные сроки поставки под заказ (от 5 рабочих дней);
- Экспресс доставка в любую точку России;
- Помощь Конструкторского Отдела и консультации квалифицированных инженеров;
- Техническая поддержка проекта, помощь в подборе аналогов, поставка прототипов;
- Поставка электронных компонентов под контролем ВП;
- Система менеджмента качества сертифицирована по Международному стандарту ISO 9001;
- При необходимости вся продукция военного и аэрокосмического назначения проходит испытания и сертификацию в лаборатории (по согласованию с заказчиком);
- Поставка специализированных компонентов военного и аэрокосмического уровня качества (Xilinx, Altera, Analog Devices, Intersil, Interpoint, Microsemi, Actel, Aeroflex, Peregrine, VPT, Syfer, Eurofarad, Texas Instruments, MS Kennedy, Miteq, Cobham, E2V, MA-COM, Hittite, Mini-Circuits, General Dynamics и др.);

Компания «Океан Электроники» является официальным дистрибьютором и эксклюзивным представителем в России одного из крупнейших производителей разъемов военного и аэрокосмического назначения «JONHON», а так же официальным дистрибьютором и эксклюзивным представителем в России производителя высокотехнологичных и надежных решений для передачи СВЧ сигналов «FORSTAR».



## JONHON

«JONHON» (основан в 1970 г.)

Разъемы специального, военного и аэрокосмического назначения:

(Применяются в военной, авиационной, аэрокосмической, морской, железнодорожной, горно- и нефтедобывающей отраслях промышленности)

«FORSTAR» (основан в 1998 г.)

ВЧ соединители, коаксиальные кабели, кабельные сборки и микроволновые компоненты:

(Применяются в телекоммуникациях гражданского и специального назначения, в средствах связи, РЛС, а так же военной, авиационной и аэрокосмической отраслях промышленности).



Телефон: 8 (812) 309-75-97 (многоканальный)

Факс: 8 (812) 320-03-32

Электронная почта: [ocean@oceanchips.ru](mailto:ocean@oceanchips.ru)

Web: <http://oceanchips.ru/>

Адрес: 198099, г. Санкт-Петербург, ул. Калинина, д. 2, корп. 4, лит. А