

Digital Heater Element Burnout Detector K8AC-H



A high-precision Heater Element Burnout Detector compatible with a wide-range of heater control methods.

- Push-in terminals reduce the workload. *1
- Scaling *1
- NPN or PNP equivalent output. *1
- Lineup includes models compatible with many heater control methods, including ON/OFF control, phase control, and cyclic control.
- High-precision heater burnout alarm with digital measurement.
- Contributes to preventative maintenance.
- If the gate function is disabled, the gate input can be used as an undercurrent/overcurrent relay or for motor or lamp loads.
- Undercurrent detection values can be set separately for CT1 and CT2. *2
- CE marking and cUL certified (K8AC-H2□□□□).

*1. K8AC-H2□□□□ Series only.

*2. The overvoltage detection value is the same for the CT1 and CT2. Also, there is one undercurrent output.

Note: 1. Consult with your OMRON representative before using the K8AC with phase control or cyclic control under the following conditions.

- Using multiple heaters with different heater capacities
- Using heaters with varying heater resistance (e.g., halogen heaters)

2. The K8AC-H is designed to monitor for element burnouts on heaters controlled with power regulators that used a three-alarm method.

Normal monitoring is not possible for circuits that use a power regulator with a six-alarm method.



Wide Current Input Range: 0.200 to 200.0 A AC.

For the most recent information on models that have been certified for safety standards, refer to your OMRON website.

Features

High-precision Heater Burnout Alarms with High-resolution Digital Measurement

Burnout Alarm Possible for One of Multiple Heater Elements

Heater burnout is detected by digitally processing minor current fluctuations.

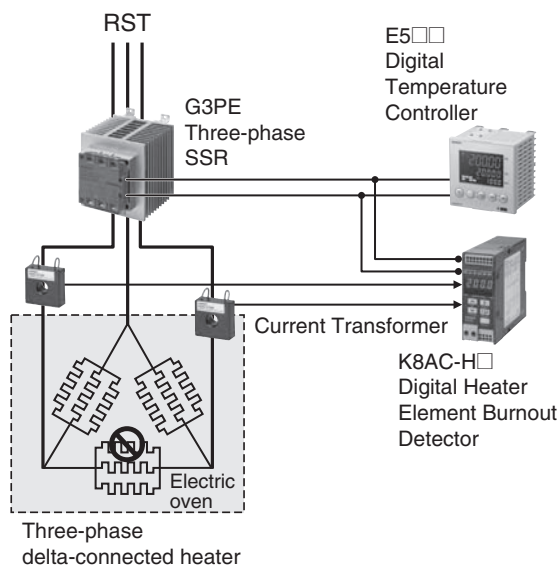

Push-in Terminals for Reduced Wiring Work (K8AC-H2□□□□ Series Only)

Push-in terminals have no screws to come loose, which eliminates the need to control screw tightening torque and retighten screws and helps to reduce your workload.

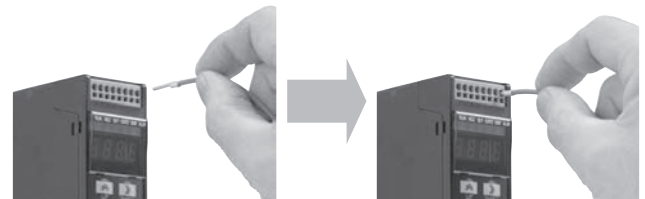

Easily connect terminals using ferrules with insulation sleeves.

Easy Scaling Using the External CT Ratio and Number of CT Passes (K8AC-H2□□□□ Series Only)

Easily set the scaling just by inputting (1) the CT ratio and (2) the number of CT passes.

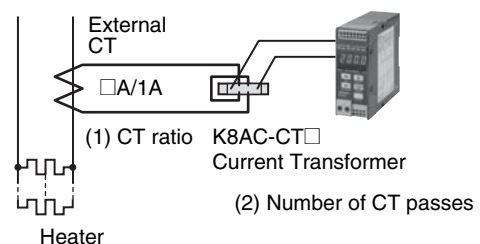

Compatible with Various Heater Control Methods

Models with heater burnout alarms for ON/OFF control, phase control, and cyclic control have been added to the lineup. Check the current input range, connected CT, and relay output type before selecting the model from the product specifications.

Note: Both single-phase and three-phase heaters are supported.

Overcurrent and SSR Failure Detection from Heater Layer Short Circuits.

- Overcurrent can be detected from layer short circuits in addition to providing heater burnout alarms with overcurrent detection settings.
- SSR short circuit failures and SSR open circuit failures are detected by monitoring the heater current and the control outputs from the temperature controller.
- Detecting SSR failures enables promptly discovering that temperature control has failed.

Heater Burnout Alarms for Cyclic Control or Phase Control Heaters

(K8AC-H□□P□)

The burnout detection value is shifted according to the control output value from the temperature controller.

- Analog control is performed on the output power according to the temperature controller's current output (4 to 20 mA) when phase control or cyclic control is used.
- Heater burnout alarms are stable with the K8AC-H because the heater burnout alarm values are linked with the control output value from the temperature controller.

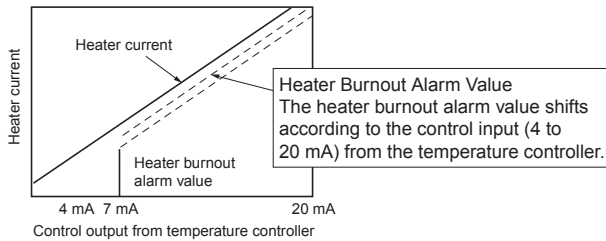

Compatible with Gradient Settings of Power Controllers

When using gradient settings with a power controller, set a gate current level that is suitable for the gradient settings.

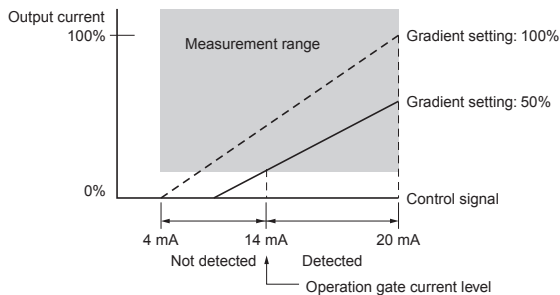

Note: Set the heater burnout alarm value based on the current at the heater's rated input.

The transistor output from the K8AC-H2□□N can be used as either an NPN open-collector output or a PNP equivalent output.

The transistor output of the K8AC-H2□□N uses a photocoupler for isolation with the internal circuits, and so either an NPN open-collector output or a PNP equivalent output can be used.

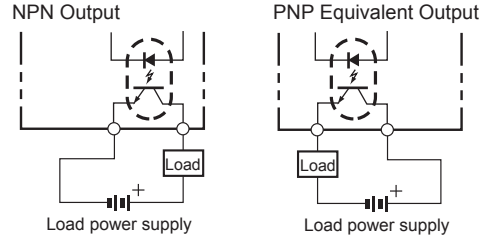

Preventive Maintenance

The run time can be measured by the K8AC-H.

Managing the run time history until burnouts occur is useful for diagnosis and preventative maintenance for equipment.

Count the Total Number of Alarms Output

Set the upper and lower limits to count the total number of alarms that have been output.

Model Number Structure

Model Number Legend

K8AC-H□□□□□**-FLK** **100-240VAC**

1 2 3 4 5 6 7

1. Basic Model

K8AC-H: Digital Heater Element Burnout Detector

2. Product Type

- 1: Screw terminals
2: Push-in terminals (Power Input: Screw Terminals.)

3. Current Input Range

- 1: 0.200 to 2.200 A
2: 2.00 to 22.00 A
3: 20.0 to 200.0 A

4. Heater Control Type

- C: ON/OFF control (SSR or contactor)
P: Phase control or cyclic control

5. Output Type

- C: Contact output (one SPDT relay contact output)
T: Transistor output (two NPN open collector outputs) *1
N: Transistor outputs (Two outputs: either NPN open-collector output or PNP equivalent output can be used.) *2
*1. K8AC-H1□□T only.
*2. K8AC-H2□□N only.

6. Communications Specifications

FLK: RS-485

7. Power Supply Voltage

100-240VAC: 100 to 240 VAC

Ordering Information

Digital Heater Element Burnout Detectors

Models with Push-in Terminals (Power Input: Screw Terminals) **NEW**

Power supply voltage	Heater control method	Input specifications	Output specifications	Communications output	Current input range		
					0.200 to 2.200 A	2.00 to 22.00 A	20.0 to 200.0 A
100 to 240 VAC	ON/OFF control SSR control	Two current inputs (for either single-phase or three-phase)	One relay output	RS-485	K8AC-H21CC-FLK	K8AC-H22CC-FLK	K8AC-H23CC-FLK
			Two transistor outputs		K8AC-H21CN-FLK	K8AC-H22CN-FLK	K8AC-H23CN-FLK
	One relay output		K8AC-H21PC-FLK		K8AC-H22PC-FLK	K8AC-H23PC-FLK	
	Two transistor outputs		K8AC-H21PN-FLK		K8AC-H22PN-FLK	K8AC-H23PN-FLK	
Applicable Current Transformer					K8AC-CT20S or K8AC-CT20L		K8AC-CT200 or K8AC-CT200L Current Transformers (sold separately)

Note: Consult with an OMRON representative if multiple heaters with different capacities are to be connected in parallel or if the heater resistance will vary.

Models with Screw Terminals **Production To Be Discontinued at the End of March 2009**

Power supply voltage	Heater control method	Input specifications	Output specifications	Communications output	Current input range		
					0.200 to 2.200 A	2.00 to 22.00 A	20.0 to 200.0 A
100 to 240 VAC	ON/OFF control SSR control	Two current inputs (for either single-phase or three-phase)	One relay output	RS-485	K8AC-H11CC-FLK	K8AC-H12CC-FLK	K8AC-H13CC-FLK
			Two transistor outputs		K8AC-H11CT-FLK	K8AC-H12CT-FLK	K8AC-H13CT-FLK
	One relay output		K8AC-H11PC-FLK		K8AC-H12PC-FLK	K8AC-H13PC-FLK	
	Two transistor outputs		K8AC-H11PT-FLK		K8AC-H12PT-FLK	K8AC-H13PT-FLK	
Applicable Current Transformer					K8AC-CT20S or K8AC-CT20L		K8AC-CT200 or K8AC-CT200L Current Transformers (sold separately)

Note: Consult with an OMRON representative if multiple heaters with different capacities are to be connected in parallel or if the heater resistance will vary.

Optional Products (Sold Separately)

Current Transformers

Through-hole diameter	Rated current	Installation method	Model
5.8-mm dia.	0.200 to 22.00 A	Surface-mounted with screws	K8AC-CT20S
		Rear-surface mounted with screws Binding band	K8AC-CT20L
12-mm dia.	20.0 to 200.0 A	Rear-surface mounted with screws Binding band	K8AC-CT200
		30-mm dia.	20.0 to 200.0 A

Note: When selecting a Current Transformer, make sure that the rated current of the heater does not exceed the rated upper limit or the rated current of the Current Transformer.

K8AC-H

Specifications

Ratings

Heater control method		Models for ON/OFF control (e.g., SSRs or contactors)	Models for phase control and cyclic control
Item	Model	K8AC-H□□□C-FLK	K8AC-H□□□P□-FLK
Power supply voltage		100 to 240 VAC (50/60 Hz) *2	
Operating voltage range		85% to 110% min. of the rated power supply voltage (85 to 264 V)	
Power consumption (at max. load)		35 VA max.	
Applicable circuits		Single-phase or three-phase (with same model)	
Applicable control methods		ON/OFF control (e.g., temperature controller with relay output) SSR control (e.g., temperature controller with voltage output) Cyclic control and phase control (e.g., temperature controller with current output)	
Input signal and applicable Current Transformer		Current measurement via two special Current Transformers (Burnout alarm set value can be set separately for each Current Transformer.) Refer to <i>Current Measurement Ranges by Model</i> on page 6 for information on the current measurement range and applicable Current Transformer.	
Measurement method		Average value calculation	
Gate input signal *1	ON/OFF control	Voltage = 12/24 VDC (continuous input possible to 30 VDC) Input impedance = 4 kΩ min.	---
	SSR control	ON voltage: 9.6 VDC max., OFF voltage: 1 VDC min. Minimum voltage pulse ON time for burnout detection: 200 ms min. Input impedance = 4 kΩ min.	---
	Cyclic and phase control	---	4 to 20 mA DC (Burnout detection is possible for an input of 7 mA or greater.) Input impedance = 50 Ω max.
Outputs	Relay contact outputs: K8AC-H□□□C-FLK	One SPDT relay contact output Same output used for heater burnout, SSR short circuit, SSR open circuit, and heater layer short circuit alarms. 0.3 A at 125 VAC (resistive load), 1 A at 30 VDC (resistive load) Maximum switching capacity: 37.5 VA, 30 W Mechanical durability: 50 million operations min., electrical durability: 100,000 operations min.	
	Transistor outputs (NPN open-collector): K8AC-H1□□T-FLK	Two transistor outputs (NPN open-collector) One ALM output: Outputs heater burnout alarm or heater layer short circuit alarm. One SSR error output: Outputs SSR short circuit alarm or SSR open circuit alarm. 12 to 24 VDC, 50 mA max. OFF leakage current: 100 μA max., ON residual voltage: 1.5 V max.	
	Transistor outputs: K8AC-H2□□N-FLK	Two transistor outputs: Can be used either NPN open-collector outputs or PNP equivalent outputs. One ALM output: Outputs heater burnout alarm or heater layer short circuit alarm. One SSR error output: Outputs SSR short circuit or SSR open circuit detection. 12 to 24 VDC, 50 mA OFF leakage current: 100 μA max., ON residual voltage: 1.5 V max.	
Communications		RS-485 1200, 2400, 4800, 9600, 19200 bps (CompoWay/F)	
Indication method		7-segment digital display: No. of display digits: 4 (red) LED status indicators: RUN (green), ADJ (orange), SET (orange), GATE (orange), SSR (orange) and ALM (orange)	
Main functions		Heater burnout alarm, heater layer short circuit alarm, SSR short circuit detection, SSR open circuit detection, voltage fluctuation compensation, output ON-delay timer, energy-saving mode, key protection, and power supply voltage measurement	
Ambient temperature	Operating	-10 to 55°C (with no icing or condensation)	
	Storage	-25 to 65°C (with no icing or condensation)	
Ambient humidity	Operating	25% to 85% (with no condensation)	
	Storage	25% to 85% (with no condensation)	
Altitude		2,000 m max.	
Accessories		Instruction sheet	
Case material		PC (Polycarbonate)	
Case color		N1.5 (clear black)	
Mounting method		Mounting to a DIN Track	

*1. The gate input enables correct measurement by syncing to heater control.

When using it with ON/OFF control, receive the relay contact output from the temperature controller or other controller with a 24-VDC auxiliary relay and then use this signal as the gate input signal to the K8AC.

The gate function can also be disabled. If it is disabled, the gate input can be used as a normal undercurrent/overcurrent relay.

*2. When using the K8AC-H for a 380 to 480-V AC power supply circuit, use a step-down transformer. Contact your OMRON representative for information on transformers.

*3. Order the Current Transformers separately.

Characteristics

Heater control method		Models for ON/OFF control (e.g., SSRs or contactors)	Models for phase control and cycle control
Item	Model	K8AC-H□□□C□-FLK	K8AC-H□□□P□-FLK
Heater current input (at 10 to 30°C) category II	Input range	K8AC-H□1□□□: 0.200 to 2.200 A (Current Transformer: K8AC-CT20S (5.8 dia.), K8AC-CT20L (12 dia.) *1) K8AC-H□2□□□: 2.00 to 22.00 A (Current Transformer: K8AC-CT20S (5.8 dia.), K8AC-CT20L (12 dia.) *1) K8AC-H□3□□□: 20.0 to 200.0 A (Current Transformer: K8AC-CT200 (12 dia.), K8AC-CT200L (30 dia.) *1)	
	Measurement accuracy	±3% rdg ±10 digits max. *2	±6% rdg ±10 digits max. (at control level of 100%) *2
Voltage fluctuation compensation category II	Input range	85 to 264 VAC	
	Measurement accuracy	±3% rdg ±10 digits max.	
Gate input	Input range	0 to 12 VDC or 0 to 24 VDC ON: 9.6 VDC max., OFF: 1 VDC min.	4 to 20 mA DC
Display cycle		Selectable: Immediate, 0.2 s, 0.5 s, 1.0 s	
Output ON-delay time		0.0 to 99.9 s (operating time)	
Soft start time		0.0 to 99.9 s (used when using the soft start function of a Power Controller)	
Output reset method		Automatic reset	
Alarm hysteresis		1 to 999 digits	
Output response time		500 ms max.	3.5 s max.
Insulation resistance		20 MΩ min. Between terminals and case Between power supply terminals/CT primary terminals and gate input terminals/communications terminals Between power supply terminals/CT primary terminals and output terminals Between gate input terminal/communications terminals and output terminals	
Dielectric strength		2,000 V for 1 min Between terminals and case Between power supply terminals/CT primary terminals and gate input terminals/communications terminals Between power supply terminals/CT primary terminals and output terminals Between gate input terminal/communications terminals and output terminals	
Noise immunity		Power supply terminals normal/common mode: ±1,500 V (startup 1-ns square-wave noise, pulse width: 1 μs/100 ns)	
Vibration resistance		Vibration: 10 to 55 Hz, Acceleration: 50 m/s ² for 5 min with 10 sweeps each in X, Y, and Z directions	
Shock resistance		150 m/s ² (100 m/s ² for relay contacts) 3 times in 6 directions in X, Y, and Z directions	
Maximum allowable input	Current Transformer primary current	K8AC-H□1□□□: 4 A: 30 s, 12 A: 1 s K8AC-H□2□□□: 40 A: 30 s, 120 A: 1 s K8AC-H□3□□□: 400 A: 30 s, 1,200 A: 1 s	
	Gate signal: 4 to 20 mA	40 mA DC continuous	
	Voltage pulse gate input	30 VDC continuous	
Input impedance	Gate signal: 4 to 20 m	50 Ω max.	
	Voltage pulse gate input	4 kΩ min.	
Weight		Approx. 200 g	
Memory protection		Non-volatile memory (number of writes: 100,000 operations)	
Installation environment		Installation Category 2, Pollution Class 2	
Approved standards		UL61010-1 and CAN/CSA C22.2 No.61010-1-04 (UL pending) EN 61010-1 (IEC 61010-1) (TÜV evaluation)	
EMC		EMI: Radiated Interference Electromagnetic Field Strength: Noise Terminal Voltage: EMS: ESD Immunity: Electromagnetic Immunity: Fast Transient Burst Immunity: Surge immunity: Conducted Noise Immunity Voltage Dip/Interrupting Immunity	EN61326-1 Industrial electromagnetic environment EN55011 Group 1, class A EN55011 Group 1, class A EN61326-1 Industrial electromagnetic environment EN61000-4-2: 4 kV (contact discharge) 8 kV (air discharge) EN61000-4-3: 10 V/m 1 kHz sine wave amplitude modulation (80 MHz to 1 GHz) EN61000-4-4: 2 kV (power line) 1 kV (I/O signal line) EN61000-4-5: 1 kV (line to line, power line) 2 kV (line to ground, power line) EN61000-4-6: 3 V (0.15 to 80 MHz) EN61000-4-11: 0.5 cycle, 0.180°, 100% (rated voltage)

Note: For phase control, the accuracy is the value when the control value of the power regulator is 100% (when the waveform of the heater current is a sine wave). "rdg" is the error in the reading of the input current.

*1. The Current Transformers are sold separately.

*2. The values for measurement current apply when the K8AC-H is used in combination with a Current Transformer.

Current Measurement Ranges by Model

Item Model	K8AC-H□1□□-FLK	K8AC-H□2□□-FLK	K8AC-H□3□□-FLK
Current measurement range	0.200 to 2.200 A AC	2.00 to 22.00 A AC	20.0 to 200.0 A AC
200 A			200.0 A
100 A			
20 A		22.00 A	20.0 A
2 A	2.200 A 0.200 A	2.00 A	
Current Transformer	K8AC-CT20S: 5.8-mm through-hole diameter or K8AC-CT20L: 12-mm through-hole diameter		K8AC-CT200: 12-mm through-hole diameter or K8AC-CT200L: 30-mm through-hole diameter

I/O Ratings

Relay Contact Output

Item	Load	Resistive load ($\cos\phi = 1$)
Rated load		125 VAC, 0.3 A, 30 VDC, 1 A
Maximum contact voltage		125 VAC, 60 VDC
Maximum contact current		1 A
Maximum switching capacity		37.5 VA, 30 W
Minimum applicable load (failure rate P value, reference value)		5 VDC, 10 mA
Mechanical life expectancy		50,000,000 operations min. (at a switching frequency of 18,000 times/h)
Electrical life expectancy (Ambient temperature condition: 20°C)		100,000 operations min. (at rated load and switching frequency of 1,800 times/h)

Transistor Output

Maximum load voltage	12 to 24 VDC (+10%, -15%)
Maximum load current	50 mA
OFF leakage current	100 μ A max.
ON residual voltage	1.5 V max.

Communications Specifications

Item	Communications	RS-485
Transmission method		Two-wire, half-duplex
Synchronization method		Start-stop synchronization
Baud rate		1,200, 2,400, 4,800, 9,600, or 19,200 bps
Transmission code		ASCII

Connections

Terminal Arrangement

K8AC-H2□□□-FLK

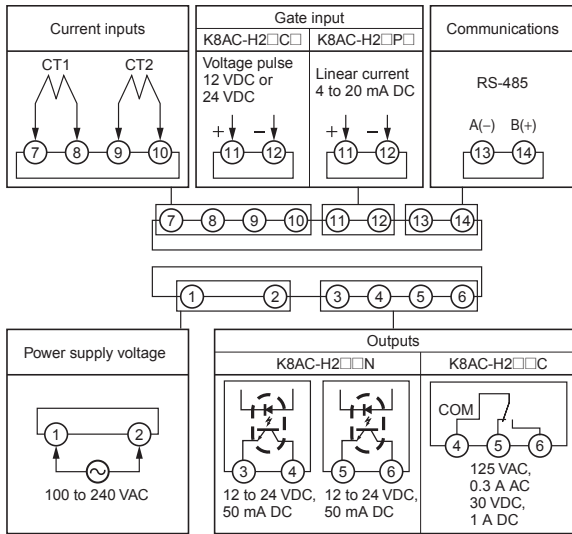

K8AC-H1□□□-FLK

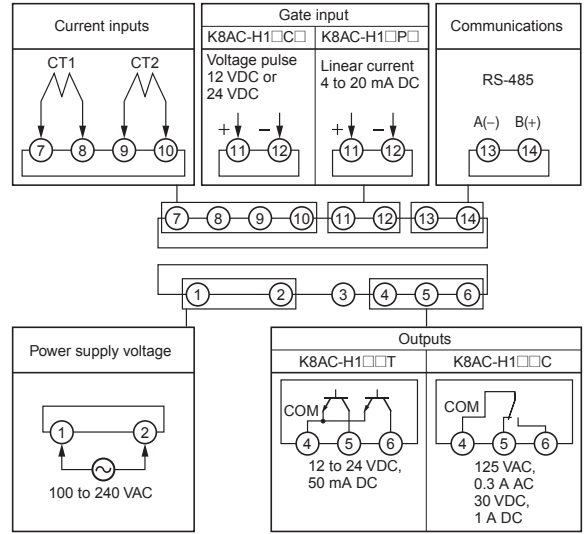

Terminals	Name	Description	Applicable models
1 to 2	Power supply voltage	Connect to the operating power supply.	All models
3 to 4, 5 to 6	Outputs	Outputs SSR open or short circuit detection results.	K8AC-H2□□□N (transistor output)
5 to 4, 6 to 4		Outputs heater burnout or layer short circuit detection results.	K8AC-H1□□□T (NPN open-collector output)
5, 6 to 4		Outputs an OR of the status of all alarms.	K8AC-H□□□C (relay output)
7 to 8, 9 to 10	Current inputs	Connect to CT1. Current input from CT1 secondary-side output. Connect to CT2. Current input from CT2 secondary-side output.	All models
11 to 12	Gate input	Connect to gate signal (voltage pulse). Connect to a 4 to 20-mA gate signal.	K8AC-H□□□C K8AC-H□□□P
13 to 14	Communications	Connect to host device for RS-485 communications.	All models

Note: 1. Terminals 4 to 6: Alarm output terminals. Depend on the output type (relay contact output or transistor output).
2. Terminals 11 and 12: Gate input terminals. Depend on the heater control type (ON-OFF/SSR control or cyclic/phase control).

Current Input Circuits

CT Inputs (Heater Current)

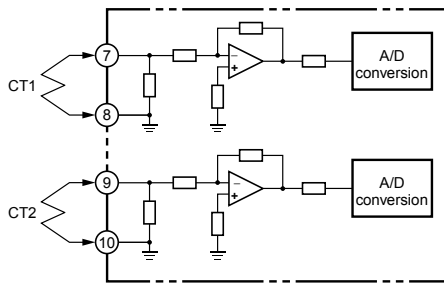

Transistor Output

K8AC-H2□□□N-FLK

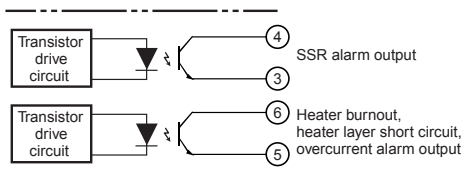

The transistor output of the K8AC-H2□□□N uses a photocoupler for isolation with the internal circuits, and so either an NPN open-collector output or a PNP equivalent output can be used.

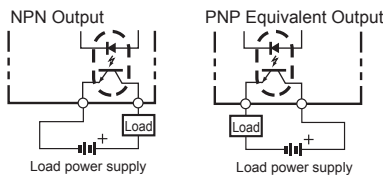

Output Circuits

Contact Outputs

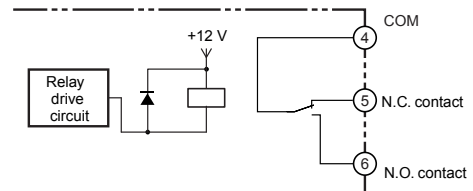

Note: For contact outputs, the same outputs are used for SSR error and for heater burnouts and heater layer short circuit alarm outputs.

K8AC-H1□□□T-FLK

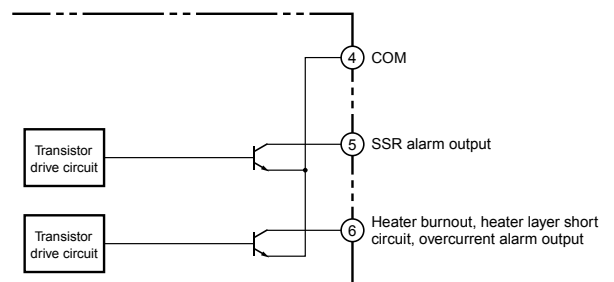

External Connection Example

Wiring Method When Using the K8AC-H with SSR Control Heaters

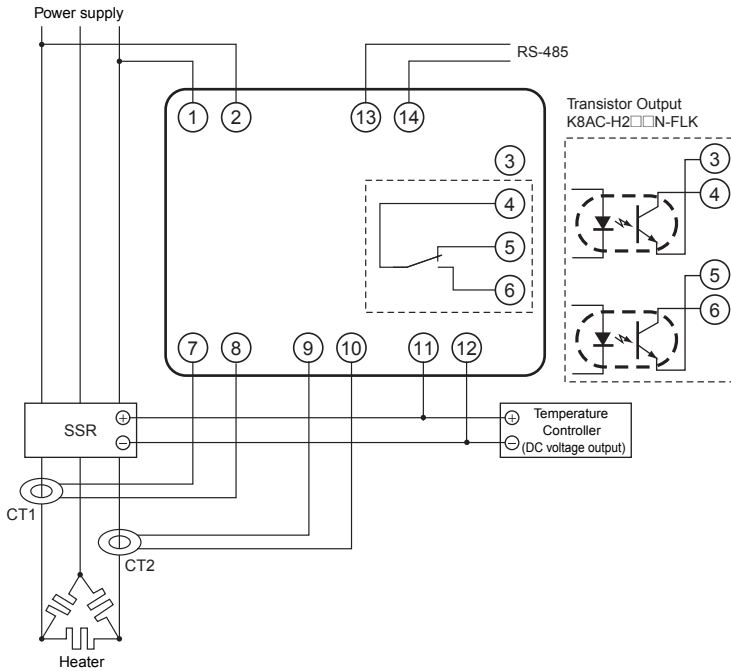

Operation Description

- If the heater current detected at either CT1 or CT2 falls below the burnout alarm set value, an alarm is output. The burnout alarm set value can be set separately for CT1 and CT2. No burnout alarm is output, however, when the temperature controller control output is OFF. Burnouts are detected only while the temperature controller control output is being input to the gate input terminals (11 and 12). Faulty outputs do not occur because heater burnout detection is linked with the temperature controller.
- The minimum burnout detection time is 200 ms. Shorter burnouts are not detected.
- Turn ON the voltage fluctuation compensation function (default: OFF) to detect power supply voltage fluctuations and automatically compensate the burnout alarm value. Also, turn ON the voltage fluctuation compensation function to detect minor current fluctuations.

Correct Usage

- Always take the power supply voltage from the primary side of the SSR.
- Use temperature controllers with a 12 or 24-VDC voltage output (30 VDC max.).
- CT1 and CT2 are special products. Use the K8AC-CT□□.
- The CTs do not have polarity.
- Connect only one CT for single-phase heaters.
- Connect two CTs for three-phase heaters.
- For three-phase heaters, always set the burnout alarm set values for both CT1 and CT2.

Wiring Method When Using the K8AC-H with ON/OFF Control Heaters

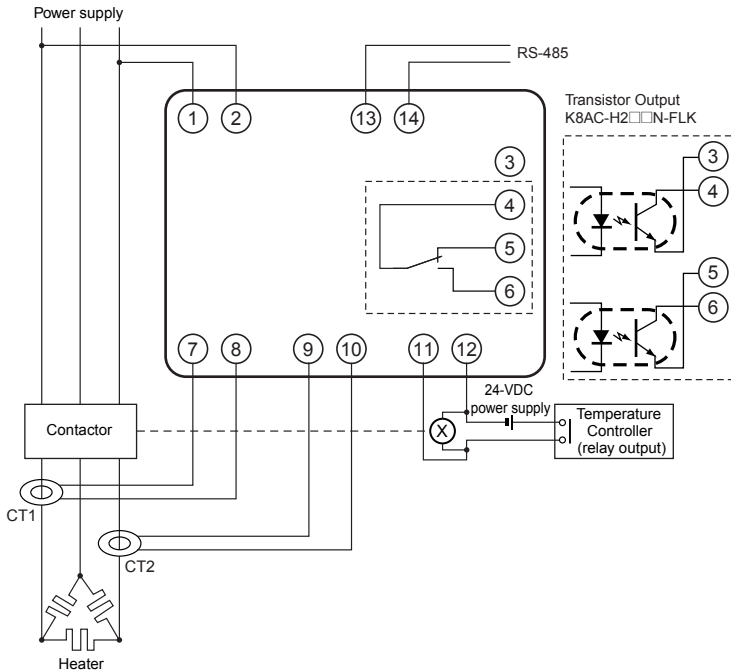

Operation Description

- If the heater current detected at either CT1 or CT2 falls below the burnout alarm set value, an alarm is output. The burnout alarm set value can be set separately for CT1 and CT2. No burnout alarm is output, however, when the temperature controller control output is OFF. Burnouts are detected only while the temperature controller control output is being input to the gate input terminals (11 and 12). Faulty outputs do not occur because heater burnout detection is linked with the temperature controller.
- The minimum burnout detection time is 200 ms. Shorter burnouts are not detected.
- Turn ON the voltage fluctuation compensation function (default: OFF) to detect power supply voltage fluctuations and automatically compensate the burnout alarm value. Also, turn ON the voltage fluctuation compensation function to detect minor current fluctuations.

Correct Usage

- Always take the power supply voltage from the primary side of the SSR.
- Use a temperature controller with relay output.
- The input to the gate input terminals (11 and 12) must be a DC voltage input, so wire the 24-VDC power supply as shown in the diagram to the left.
- CT1 and CT2 are special products. Use K8AC-CT□□.
- The CTs do not have polarity.
- Connect only one CT for single-phase heaters.
- Connect two CTs for three-phase heaters.
- For three-phase heaters, always set the burnout alarm set values for both CT1 and CT2.

Wiring Method When Using the K8AC-H with Cyclic Control Heaters

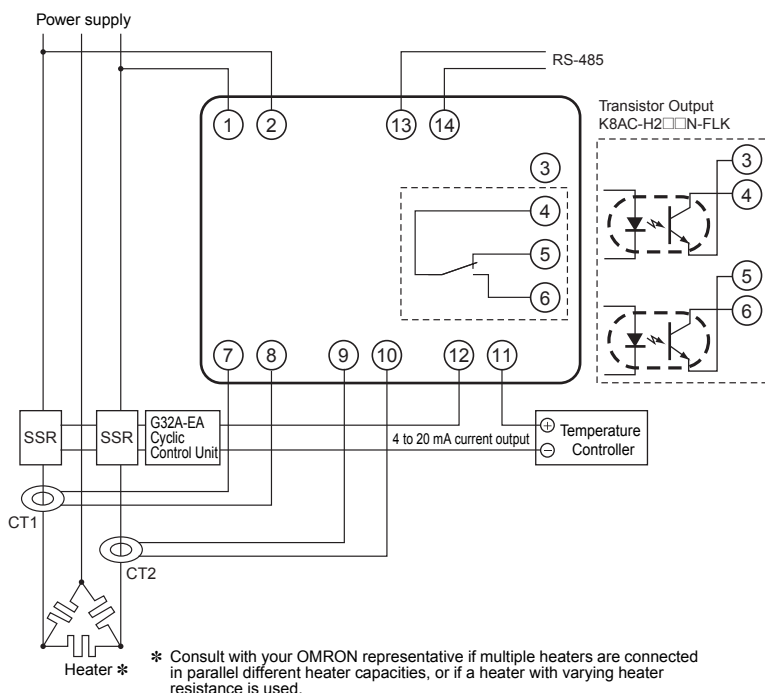

Operation Description

- If the heater current detected at either CT1 or CT2 falls below the burnout alarm set value, an alarm is output. The burnout alarm set value can be set separately for CT1 and CT2. No burnout alarm is output, however, when the temperature controller control output is OFF.
- Burnouts are detected only while the temperature controller control output is being input to the gate input terminals (11 and 12). Burnout is detected with no errors because the automatic adjustment of burnout alarm level is linked to the temperature controller control output (4 to 20 mA).
- Burnout is detected when control outputs from the temperature controller are 7 mA min.

Correct Usage

- Always take the power supply voltage from the primary side of the SSR.
- Use a temperature controller with a 4 to 20-mA current output.
- When you adjust the set value for the burnout alarm, make sure that you make the setting with the temperature controller's control output at a 100% output. The burnout detection value is the detection value at 100% output. Therefore, correct operation will not be possible if the setting is made based on a measurement value when the output is not 100%.
- CT1 and CT2 are special products. Use K8AC-CT□□.
- The CTs do not have polarity.
- Connect only one CT for single-phase heaters.
- Connect two CTs for three-phase heaters.
- For three-phase heaters, always set the burnout alarm set values for both CT1 and CT2.

Wiring Method When Using the K8AC-H with Phase Control Heaters

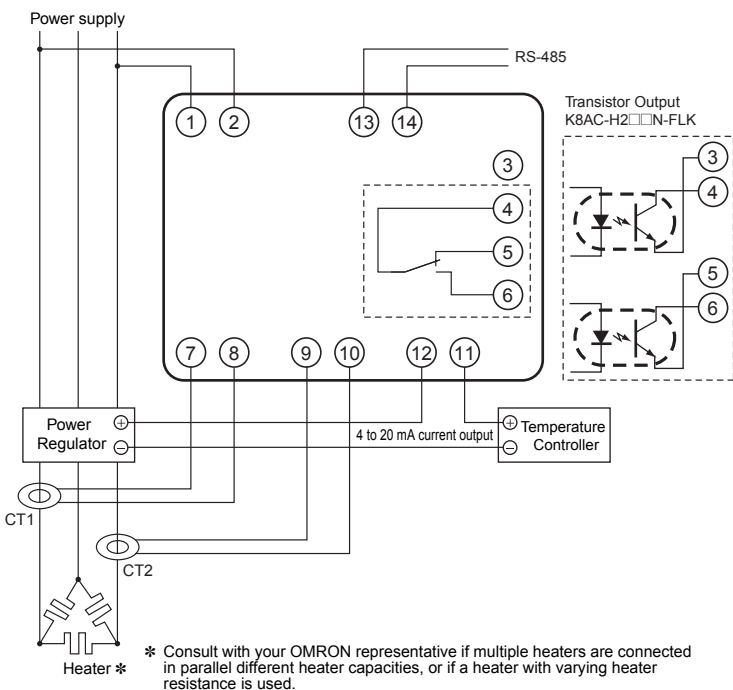

Operation Description

- If the heater current detected at either CT1 or CT2 falls below the burnout alarm set value, an alarm is output. The burnout alarm set value can be set separately for CT1 and CT2. No burnout alarm is output, however, when the temperature controller control output is OFF.
- Burnouts are detected only while the temperature controller control output is being input to the gate input terminals (11 and 12). Burnout is detected with no errors because the automatic adjustment of burnout alarm level is linked to the temperature controller control output (4 to 20 mA).
- Burnout is detected when control outputs from the temperature controller are 7 mA min.

Correct Usage

- Always take the power supply voltage from the primary side of the contactor.
- Use a temperature controller with a 4 to 20-mA current output.
- When you adjust the set value for the burnout alarm, make sure that you make the setting with the temperature controller's control output at a 100% output (20 mA). The burnout detection value is the detection value at a 100% output. Therefore, correct operation will not be possible if the setting is made based on a measurement value when the output is not 100%.
- Adjust the burnout alarm set value at a 100% output for gradient settings as well.
- If using the soft startup function with a power regulator, set the soft startup function on the K8AC-H as well, to prevent malfunctions.
- CT1 and CT2 are special products. Use K8AC-CT□□.
- The CTs do not have polarity.
- Connect only one CT for single-phase heaters.
- Connect two CTs for three-phase heaters.
- For three-phase heaters, always set the burnout alarm set values for both CT1 and CT2.
- When using the power regulator's gradient settings, change the operation gate current level so that the heater current value is within the measurement range. (The initial value is 7 mA.) For details on operating methods, refer to pages 16 to 18.

Heater Connection Methods and Current

Depending on the heater connection method, the current when an error occurs will be as shown in the following table. Refer to this table when determining burnout alarm set values.

		Normal condition	Abnormal condition	
Three-phase	Single-phase			
	Delta connection			
	Star connection			
	V connection			

Note: This is the current for when a 200-V, 1-kW heater is used for single-phase or three-phase operation.

Rate of Change for Currents with Parallel Heaters

The following table shows the current change ratios when multiple heaters of the same capacity are connected in parallel and one of the heater elements burns out. Use this table for reference when making corrections.

If five single-phase heaters are connected in parallel, the current change when burnout occurs is 20% per heater.

For example, if the current for a single heater is low and the change ratio is very slight, it may not be detected. Therefore take into account the detection accuracy for the total current when selecting the number of heaters to be connected in parallel.

Connection		n=1	n=2	n=3	n=4	n=5	
Single-phase		With one heater burned out, I is 0.	0.5	0.67	0.75	0.8	
Star connection		Current in burned-out phase	With one heater burned out, I is 0.	0.6	0.75	0.82	0.86
		Current in other phases	0.87	0.92	0.95	0.96	0.97
Delta connection		Current in lines near burned-out phase (Same as 2-phase.)	0.58	0.77	0.84	0.88	0.91
		Current in other phases	1	1	1	1	1

Note: 1. The figures in the above table show the current change ratios when burnout occurs for one heater connected in parallel.

- The numbers represent the current ratio after one heater burns out, with the current prior to the burnout (i.e., the normal current) taken as 1.
- In actual operation there may be effects from factors such as load (heater) imbalances, so conduct an actual test for confirmation before making adjustments if the current change ratio between normal and abnormal operation is slight.
- Consult with your OMRON representative if multiple heaters are used with different heater capacities.

Operation

Main K8AC-H Functions

The K8AC-H is a digital heater burnout detector that detects heater burnout by measuring the heater current from various power supply systems. The K8AC-H provides the following functions.

Applicable Heater Control Methods

The following heater control methods can be used.

ON/OFF Control (Contactor/SSR)

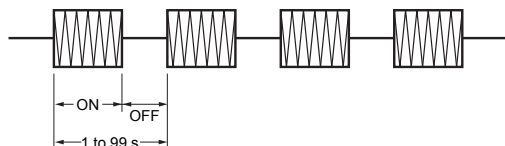

Cyclic Control

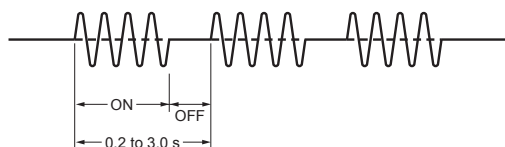

Phase Control (Applicable to 4 to 20 mA Current-output Temperature Controllers)

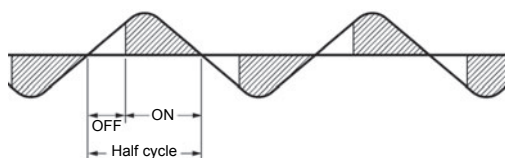

Heater Burnout Alarm

The preset burnout detection value is compared with the heater current and an alarm is output accordingly.

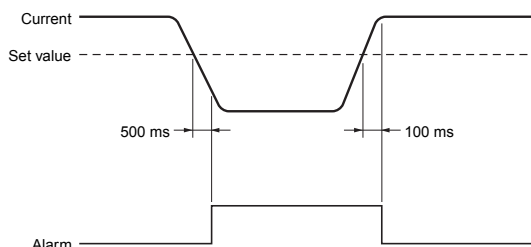

Transistor output models: ALM indicator lit, ALM transistor output
Relay output models: ALM indicator lit, OR of all detection status output

Error Detection

The following errors are detected according to status.

Heater Layer Short Circuit Detection (overcurrent detection).

Layer short circuits can be detected in the heater. The preset overcurrent detection set value is compared with the heater current and an alarm is output accordingly.

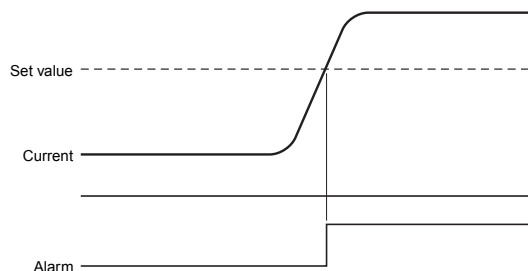

Transistor output models: ALM indicator lit, ALM transistor output
Relay output models: ALM indicator lit, OR of all detection status output

SSR Short Circuit Detection

If current is measured when there is no gate input, an SSR short circuit error is detected and an alarm is output.

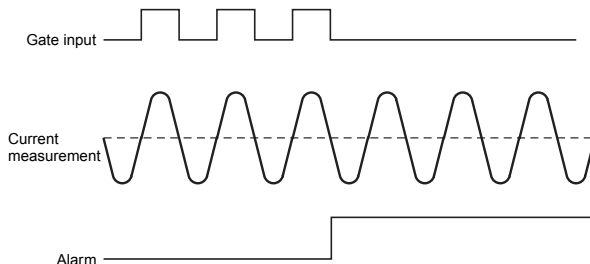

Transistor output models: SSR indicator lit, SSR transistor output
Relay output models: SSR indicator lit, OR of all detection status output

SSR Open Circuit Detection

If current is not measured during gate input, an SSR open circuit error is detected and an alarm is output.

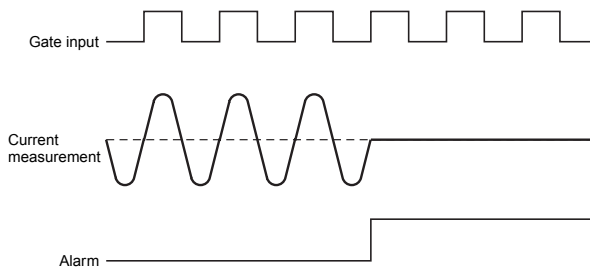

Transistor output models: SSR indicator lit, SSR transistor output
Relay output models: SSR indicator lit, OR of all detection status output

Voltage Fluctuation Compensation

The voltage fluctuation compensation function automatically adjusts the burnout alarm value of the K8AC-H according to voltage fluctuations in the heater circuit.

The operating value for burnout detection when multiple heaters are connected is set very close to the normal value. Thus, a false burnout alarm output will occur if there is a voltage drop in the heater circuit. The voltage fluctuation compensation function prevents this type of false output.

Example: Voltage Drop from 100 V to 95 V in the Heater Circuit

Conditions:

Voltage fluctuation compensation standard value = 100 V

Burnout alarm set value = 10.0 A

If the power supply voltage drops from 100% to 95%, the operating value will also be reduced from 100% to 95%.

Burnout alarm operating value = $10.0 \text{ A} \times 95\% = 9.5 \text{ A}$

Gate Input

The gate input provides a sync signal used to link burnout detection to the control output of the temperature controller.

For SSR control, the voltage output pulse from the temperature controller is input.

For ON/OFF control, 24 VDC linked to a relay contact of the temperature controller is input.

For cyclic or phase control, a 4 to 20-mA control signal is input.

If there is no gate input for a Heater Element Burnout Detector, a heater burnout alarm would be falsely output when the voltage output pulse from the temperature controller turns OFF, and there would be no way to tell whether it was a false output.

Note: The gate input function can be disabled. If it is disabled, Heater Element Burnout Detector operation will not be linked to the temperature controller control signal. (The gate input can be used as a simple undercurrent relay.)

Power-saving Operation

If there are no key operations performed within a preset time period, the display automatically turns OFF.

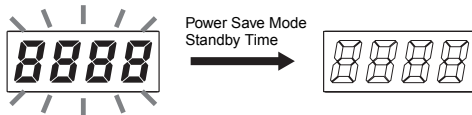

Output Operation Time Charts

Heater Burnout and Heater Layer Short Circuit (Overcurrent) Alarms

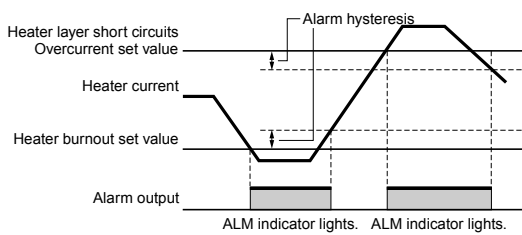

SSR Short/Open Circuit Alarm

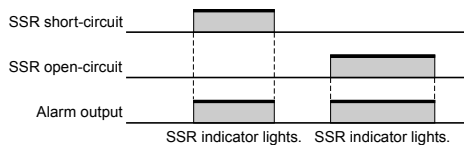

Using the Power Regulator's Gradient Settings

The power regulator's gradient settings can be used to prevent malfunction by setting the operation gate current level. The relationship between the gradient settings and output current depends on the power regulator manufacturer and model, so be sure to check the characteristics of the power regulator being used before setting.

Setting Example

Initial setting: 7 mA

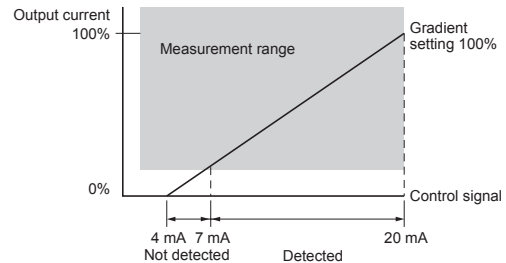

When the power regulator's gradient settings are changed, the operation gate current level is set so that the output current is within the measurement range. (In the following diagram, 14 mA is set.)

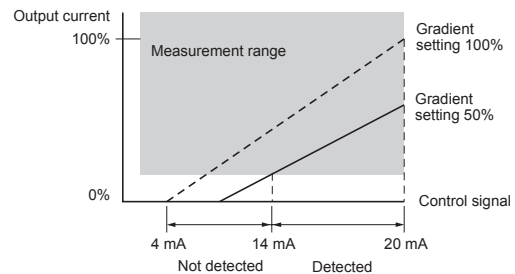

Using Halogen or Other Heaters with Varying Resistance during Phase and Cyclic Control

When phase control is used with halogen heaters or other pure metal heaters, the heater resistance fluctuates according to the control level. As a result, high-precision detection of heater burnout is not possible. The effect on the heater and setting methods depends on the heater being used. Therefore, consult with your OMRON representative before using a heater with varying resistance values.

Halogen Heater Resistance Fluctuation Example

In the following example, burnout of one element in a six-element heater can be detected at a control level of 20 mA, but detection is not possible due to the effect of fluctuating resistance if the control level is any lower.

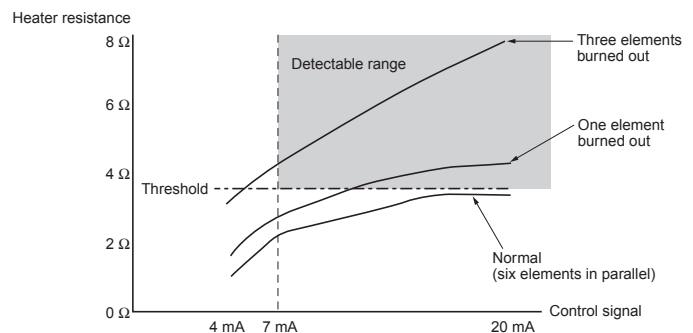

Nomenclature

Nomenclature and Operations

K8AC-H2□□□-FLK

K8AC-H1□□□-FLK

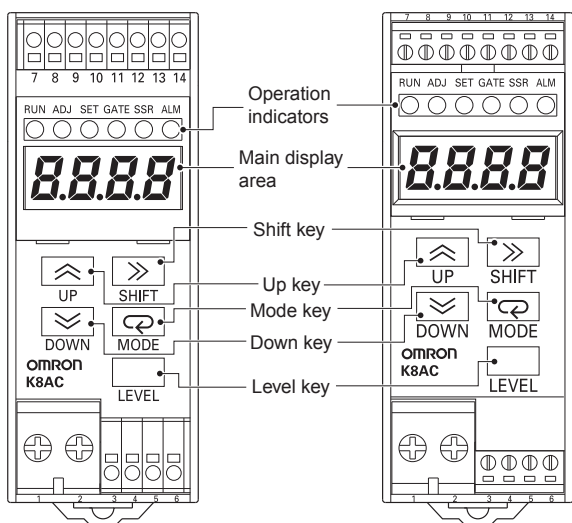

Name	Operation
Main display	Displays processing values, parameter characters, and set values.
Operation indicators	
RUN (Measurement operation)	Lights when the power is turned ON and the measurement operation is in progress. OFF at all other times.
ADJ (Adjust)	Lights while in Adjust Mode. Flashes while in Test Mode. OFF at all other times.
SET (Set)	Lights while in Set Mode. OFF at all other times.
GATE (Gate)	Lights or turns OFF according to gate input status. Gate pulse: Lights for high voltage pulse; OFF for low voltage pulse. Gate signal (4 to 20 mA): Lights for 4 mA or over; OFF for less than 4 mA.
SSR (SSR error) *	Lights when an SSR error occurs (open or short circuit). OFF when SSR is normal.
ALM (Alarm) *	Lights for heater burnout or overcurrent. OFF at all other times.
Up key	Increments a set value when the set value is in change status.
Down key	Decrements a set value when the set value is in change status.
Shift key	Used to check set values while parameters are displayed, and to put set values in change status. Used to shift the set value digit when the set value is in change status.
Mode key	Used to switch the displayed parameter.
Level key	Used to change the level.

* Check the specific status using the alarm display parameters on the main display.

Alarm Indicator

Order of priority	Alarm	7-segment display characters	LED indicator	Alarm contents
1	Heater burnout 1	Hb t 1	ALM indicator lit	CT1 heater burnout detected.
2	Heater burnout 2	Hb t 2	ALM indicator lit	CT2 heater burnout detected.
3	SSR open circuit	SS r a	SSR indicator lit	SSR open circuit detected (when heater current cannot be detected with temperature control gate output ON).
4	SSR short circuit	SS r S	SSR indicator lit	SSR short circuit detected (when heater current is detected with temperature control gate output OFF).
5	Heater layer short circuit 1	Hr S 1	ALM indicator lit	CT1 overcurrent detected.
6	Heater layer short circuit 2	Hr S 2	ALM indicator lit	CT2 overcurrent detected.

- Note:**
- As soon as the cause of an alarm is removed, the alarm is reset automatically.
 - If multiple alarms occur simultaneously, the one with the highest priority is displayed.
 - If the mode is changed to Adjust or Set Mode while an alarm is in effect, the alarm output is reset and the ALM and SSR indicators turn OFF.

Processing Value Display Ranges and Functions

Processing value name	Display characters	Display range	Unit	Function
Heater 1 current	It 1	0100 to 2300 *1 *2	A	This is the CT1 heater current processing value. Alarm operations such as the heater burnout alarm are determined based on this processing value.
Heater 2 current	It 2	0100 to 2300 *1 *2	A	This is the CT2 heater current processing value. Alarm operations such as the heater burnout alarm are determined based on this processing value.

*1. The decimal point position depends on the input type.

K8AC-H□1□□: 0.100 to 2.300

K8AC-H□2□□: 1.00 to 23.00

K8AC-H□3□□: 10.0 to 210.0

*2. If the display is below 0100, the bar display "----" will be shown.

Settings Method

Settings Methods for SSR and ON/OFF Control Heaters

Settings Conditions

Detecting burnouts in just one heater when ten 300-W rated heaters are connected in parallel to a single-phase 200-V power supply. The heater is SSR controlled.

Normal Heater Current and Heater Current with One Heater Element Burnout

Normal current = $(300\text{ W} \times 10\text{ (heaters)})/200\text{ V} = 15.0\text{ A}$

Current with one burnout = $(300\text{ W} \times 9)/200\text{ V} = 13.5\text{ A}$

Heater burnout alarm set value =

$$\frac{(\text{Normal current} + \text{current at malfunction})}{2} = \frac{15.0 + 13.5}{2} = 14.3\text{ A}$$

Selecting Heater Element Burnout Detector Models

For the above example, K8AC-H12C□-FLK would be selected. The burnout alarm set value is 14.3 A, so the current input range 2.00 to 22.00 A should be selected.

SSR control is used, so type C should be selected. (Type C is also selected for ON/OFF control.)

Select the appropriate relay or transistor output specifications, depending on the application.

K8AC-H Parameter Setting Procedure

(Only the minimum settings are shown here. Refer to pages 16 to 18 for information on how to set parameters.)

1. Turn ON the power to the K8AC-H. The initial status when power is turned ON is called Run Mode.
2. Press the Key for at least 3 s to change from Run Mode to Adjust Mode (the mode for adjusting burnout alarm set values.)
3. Set the burnout alarm set values. (AL-1 = CT1 burnout alarm set value and AL-2 = CT2 burnout alarm set value.)
Set "14.3" to AL-1.
Set the AL-2 burnout alarm set value to "----" so that it will not detect heater burnout, because this is a single-phase heater.
4. Change to Run Mode.
Press the Key while in Adjust Mode for at least 1 s to change to Run Mode.
5. Check operation.
Test heater burnout detection by burning out one heater. Also check that there are no malfunctions during temperature control.

Note: The default setting for functions including the voltage fluctuation compensation function, alarm hysteresis, output ON-delay time, and SSR error detection function is OFF. Turn ON any of these functions as required.

Settings Method for Cyclic and Phase Control Heaters

Settings Conditions

Detecting burnouts in one heater when five 1,000 W-rated heaters are connected to each phase of a three-phase delta-connected 200-V power supply.

A power regulator (phase control) performs heater control.

Normal Heater Current and Heater Current With One Heater Element Burnout

Example: When One of Five Single-phase Heaters (R-S) Burns Out

Normal current = $\sqrt{3}\text{ (1,000 W} \times 5\text{ (heaters)})/200\text{ V} = 43.3\text{ A}$

Current with one burnout = $43.3\text{ A} \times 0.91 = 39.4\text{ A}$

(Refer to *Rate of Change for Currents with Parallel Heaters* on page 10.)

Heater burnout alarm set value =

$$\frac{\text{Normal current} + \text{current at malfunction}}{2} = \frac{43.3 + 39.4}{2} = 41.4\text{ A}$$

Selecting Heater Element Burnout Detector Models

For the above example, K8AC-H13P□-FLK would be selected. The burnout alarm set value is 41.4 A, so the current input range 20.0 to 200.0 A should be selected.

Phase control is used, so type P should be selected. (Type P is also selected for cyclic control.)

Select the appropriate relay or transistor output specifications, depending on the application.

K8AC-H Parameter Settings Procedure

(Only the minimum settings are shown here. Refer to pages 16 to 18 for information on how to set parameters.)

1. Turn ON the power to the K8AC-H. The initial status when power is turned ON is called Run Mode.
2. Press the Key for at least 3 s to change from Run Mode to Adjust Mode (the mode for adjusting burnout alarm set values.)
3. Change from Adjust Mode to Set Mode (the default settings mode for all functions). The password "0169" is required to move to Set Mode.
4. Set the heater control method parameter to PH-3 (three-phase control).
The default setting is PH-1 (single-phase control).
Note: Set the parameter to CYCL (cyclic control) when using cyclic control.
5. Press the Key for at least 1 s to change from Set Mode to Adjust Mode. Press the Key again for at least 1 s to change from Adjust Mode to Run Mode.

Note: The default setting for functions including the voltage fluctuation compensation function, alarm hysteresis, output

ON-delay time, and SSR error detection function is OFF. Turn ON any of these functions as required.

Burnout Alarm Set Value Setting Method

Setting Method

- Wire the K8AC-H, temperature controller (4 to 20 mA current output type), and power regulator (phase control).
- Press the Key on the K8AC-H for at least 3 s to change from Run Mode to Adjust Mode.
- AL-1 (CT1 burnout alarm set value) will be displayed when the mode is changed to Adjust Mode. Press the key once when AL-1 is displayed. Next, press the Key once. The present heater current value will be displayed on the main display, so note this as the normal current value. Always have the temperature controller output at 20.0 mA at this time (See note 1.)
- Next, disconnect one heater and note the heater current in this burnout state. Alternatively, use the current when one heater is burned out (calculated earlier) as the current during malfunction. It is recommended that the current at an actual burnout is confirmed.
- Set the K8AC-H burnout alarm set value based on the results. The burnout alarm set value is set at the mid-point between the normal current and the current at malfunction, taking errors and variations in heater capacity into consideration.
- In this setting example, the set value for AL-2 (CT2 burnout alarm setting) is the same as the set value for AL-1. (See note 2.)

Note: 1. The K8AC-H automatically adjusts burnout alarm levels to compensate based on the temperature controller current output. The burnout alarm value must be set when the temperature controller output is at 100% (20 mA), so be sure to have the temperature controller at 20 mA output.
2. If the heater capacity is unbalanced, the burnout alarm values for CT1 and CT2 may not be the same.

Measurement Monitor Value Display Ranges and Functions

Other than measuring the heater current, the K8AC-H can measure the power supply voltage, maximum/minimum current, maximum/minimum voltage, and other values. The measurement data can be monitored from a host using RS-485 communications. The measurement monitor value names, display ranges, and functions are given in the following table.

Measurement monitor value name	Display characters	Display range	Unit	Function
Power supply voltage	5EE	0085 to 0264	V	This is the measurement value of the K8AC-H power supply voltage. When the voltage fluctuation compensation function is enabled, the heater burnout determination based on this voltage is automatically compensated.
Heater 1 maximum current *	ñññ!	0100 to 2300	A	These hold the maximum and minimum values for each processing value. <ul style="list-style-type: none"> • The maximum and minimum heater currents after the power is turned ON or after a maximum or minimum reset are displayed. • The values are not saved when power is interrupted. • The current values are not refreshed when startup lock is in effect and when the gate input is enabled but the gate input is OFF. • Measurement values for power supply voltages are always refreshed.
Heater 1 minimum current *	ñññ!	0100 to 2300	A	
Heater 2 maximum current *	ñññ2	0100 to 2300	A	
Heater 2 minimum current *	ñññ2	0100 to 2300	A	
Maximum power supply voltage *	ñññ5	0085 to 0264	V	
Minimum power supply voltage *	ñññ5	0085 to 0264	V	
Number of alarm outputs	ññññ	0000 to 9999	Outputs	This value counts the total number of alarms output for heater burnout, SSR open and short circuits, and heater layer shorts. <ul style="list-style-type: none"> • The count is refreshed each time an alarm is output, and it is saved in non-volatile memory. • The value is saved when power is interrupted. • The number of outputs is not counted for the test function.
Processing value for alarm output	ññññ	0100 to 2300	A	This holds the CT1 or CT2 processing value when a heater burnout alarm is output. <ul style="list-style-type: none"> • This is the most recent processing value, and it is refreshed each time a heater burnout alarm occurs. • The value is not saved when power is interrupted.
Run time	ññññ	0000 to 9999	× 10h	This is the total run time value from when power is turned ON or the processing value is reset until an alarm occurs. <ul style="list-style-type: none"> • The total time is recorded in non-volatile memory approximately once per hour. If power is interrupted within the hour, however, the data since the beginning of the hour is lost and the total starts over from when the time was last saved. • The total is stopped during heater burnout alarm output. When the alarm is cleared, the total resumes from the time just before the alarm occurred.
Heater 1 input shift display current	ñññ!	-999 to 999	digit	This is the shift value for displaying the CT1 heater current measurement set in measurement parameter CT1. <ul style="list-style-type: none"> • The value is saved when power is interrupted.
Heater 2 input shift display current	ñññ2	-999 to 999	digit	This is the shift value for displaying the CT2 heater current measurement set in measurement parameter CT2. <ul style="list-style-type: none"> • The value is saved when power is interrupted.

* Each measurement value can be individually reset. Refer to the *K8AC-H Digital Heater Element Burnout Detector User's Manual* (Cat. No. N132) for operating procedures.

Modes

Groups of setting items are called "modes." The K8AC-H has five modes.

Mode	Function	Alarm operation
Run Mode	This is the normal operating mode, used for receiving inputs, executing heater burnout outputs, etc. Operation goes into Run Mode immediately after power is turned ON.	Executed
Adjust Mode	This mode is used to change comparatively frequently set parameters, such as alarm value settings. This also the mode for entering the password to move to the Set Mode.	Stopped
Set Mode	This mode is used to make the initial settings for the various functions.	Stopped
Protection Settings Mode	This mode is used to make settings to prevent unintended key operations. The protected modes are not displayed, preventing changes to set values.	Stopped
Test Mode	This mode is used to simulate inputs with key operations to test alarm outputs.	Executed
Gate Mode	This mode sets the gate current value that stops an alarm or detection.	Executed

Note: If more than five minutes elapses with no operations performed in the Protection Settings Mode, Adjust Mode, or Set Mode, the status will return automatically to the processing value display. If this occurs while settings are in progress, it may cause unintended operations in the processing value display. Be careful not to allow this to happen.

Settings Data Notation

The letters of the alphabet in settings data are displayed as shown below.

A	B	C	D	E	F	G	H	I	J	K	L	M	N	O	P	Q	R	S	T	U	V	W	X	Y	Z
ñ	ñ	ñ	ñ	ñ	ñ	ñ	ñ	ñ	ñ	ñ	ñ	ñ	ñ	ñ	ñ	ñ	ñ	ñ	ñ	ñ	ñ	ñ	ñ	ñ	ñ

Operating Procedures

Moving between Modes

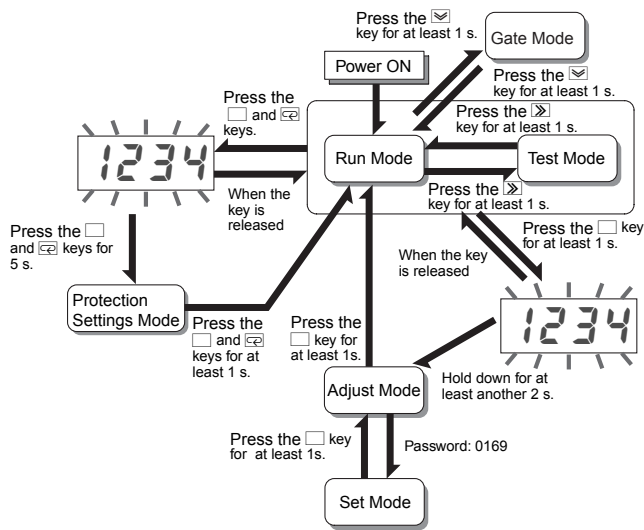

To Adjust Mode

When the \square key is pressed for one second in Run Mode, the 7-segment display will begin to flash. If the key is held down for another two seconds, the mode will be switched to Adjust Mode. To return to Run Mode from Adjust Mode, press the \square key for at least one second.

To Protection Settings Mode

When the \square and C keys are pressed for one second in Run Mode, the 7-segment display will begin to flash. If the keys are held down for another five seconds, the mode will be switched to Protection Settings Mode. To return to Run Mode from Protection Settings Mode, press \square and C keys for at least one second.

To Gate Mode

When the \checkmark key is pressed for at least one second in Run Mode, the mode will be switched to Gate Mode. To return to Run Mode from Gate Mode, press the \checkmark key for at least one second.

To Test Mode

When the \gg key is pressed for at least one second in Run Mode, the mode will be switched to Test Mode. To return to Run Mode from Test Mode, press the \gg key for at least one second.

To Set Mode (Password Input)

A special operation is required to move to the Set Mode. Use the following procedure.

Procedure

- Move to the Adjust Mode and use the C key to display the parameter for moving to the Set Mode.
 - The parameter characters are "A \checkmark 00".
- Press the \gg key to display the set value (password).
- Press the \gg key again to enable changing the password.
- Use \gg , \checkmark , and \gg keys to set the password. The password is 0169.

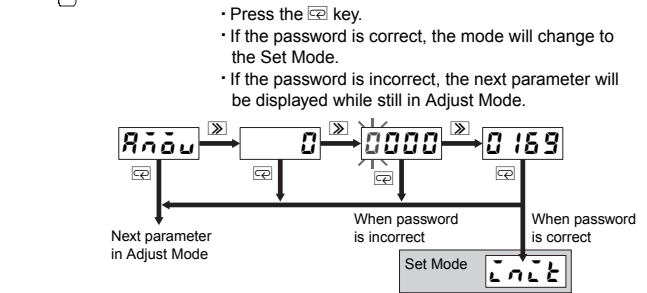

Setting the Parameter

The value set for each parameter is called the "set value." Set values include both numbers and characters.

The status when a set value is displayed is called "monitor status," and when it can be changed it is called "change status."

Use the following procedure to display and change set values.

Procedure

- Press the \gg key while a parameter is displayed to go into monitor status. The set value for that parameter will be displayed.
 - If the set value is not to be changed, press the C key while in monitor status to switch to the next parameter.
 - Press the \gg key again while in monitor status to enable the changing set value.
- The place where the set value can be changed will begin to flash.
- Use the \gg , \checkmark , and \gg keys to change the set value.
 - Press the C key to save the changed set value in internal memory and switch to the next parameter.

Note:

If a set value is out of range, either too high or too low, the maximum or minimum value will automatically be set. For models with a current input of 0.200 to 2.200 A, for example, the maximum value is 2.200 and the minimum value is 0.200.

- Changed set values will not be saved in memory if the mode is changed by another key operation without first pressing the C key.

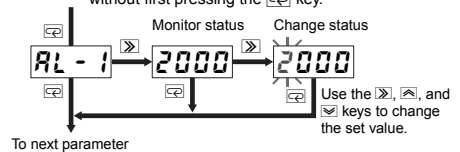

Parameter List

The setting items in each mode are called "parameters."
Parameters can be switched by using the  key.

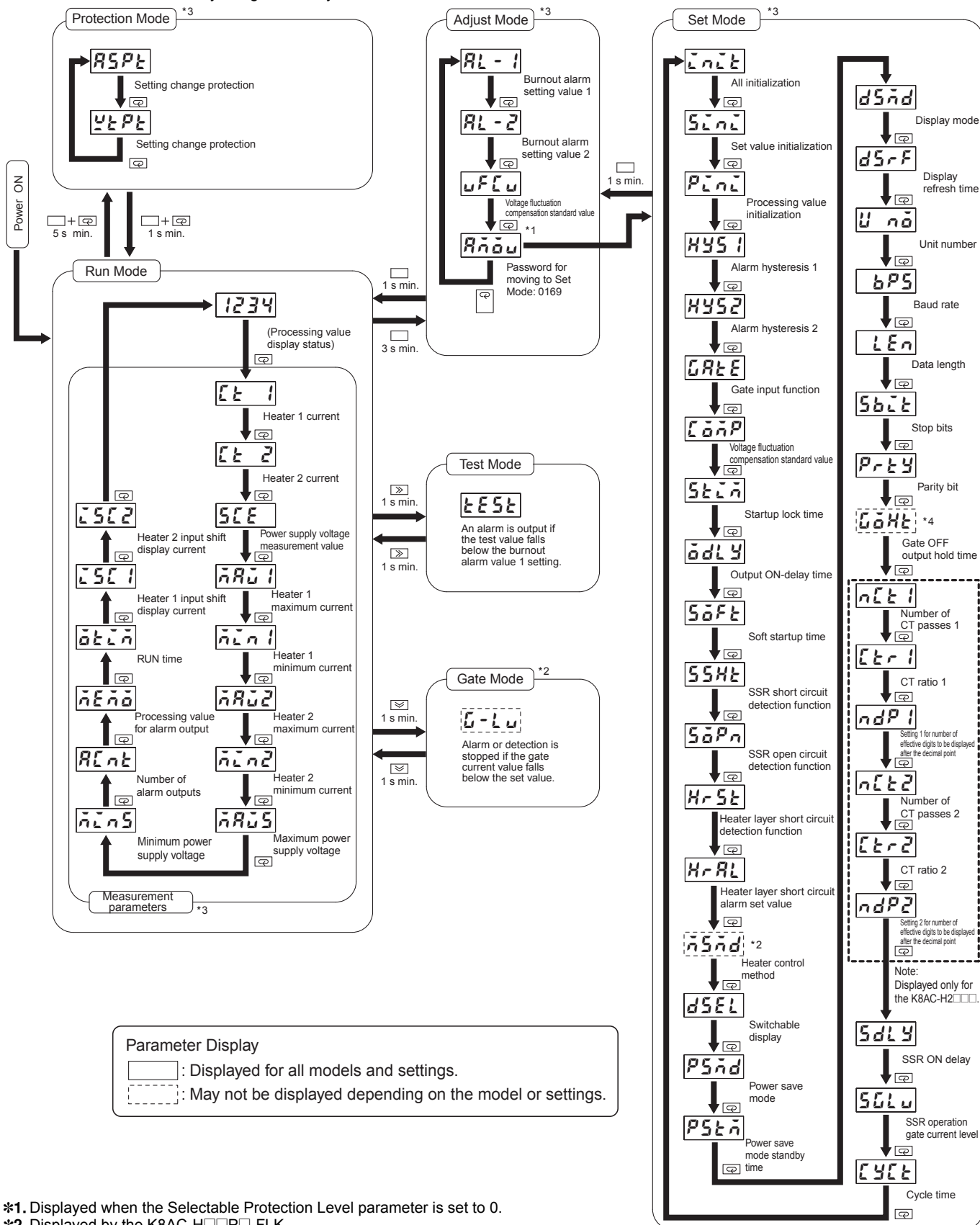

*1. Displayed when the Selectable Protection Level parameter is set to 0.
 *2. Displayed by the K8AC-H□□P□-FLK.
 *3. If more than five minutes elapses with no operations performed in Protection Settings Mode, Adjust Mode, Set Mode, or for a measurement parameter, the status will return automatically to the processing value display. If this occurs while settings are in progress, it may cause unintended operations to be performed in Run Mode (i.e., with measurement values displayed). Be careful not to allow this to happen.
 *4. Displayed by the K8AC-H□□C□-FLK.

Parameter Defaults and Descriptions

Note: Shaded parameters must always be set regardless of the measurement method.

Item Mode	Parameter name	Description	Parameter	Setting range	Default	
Protection Mode	Setting Change Protection	Restricts access to Adjust Mode or Set Mode from Run Mode. 0: Access enabled to both Adjust Mode and Set Mode. 1: Access enabled to Adjust Mode and disabled to Set Mode. 2: Access disabled to both Adjust Mode and Set Mode.	RSPE	0 to 2	0	
	Setting Value Change Prohibition	Prohibits changes to set values.	YEP	ON/OFF	OFF	
Adjust Mode	Burnout Alarm Value 1	K8AC-H□1	RL - 1	0.200 to 2.200 A	1.000 A	
		K8AC-H□2		2.00 to 22.00 A	10.00 A	
		K8AC-H□3		20.0 to 200.0 A	100.0 A	
	Burnout Alarm Value 2	K8AC-H□1	RL - 2	0.200 to 2.200 A	1.000 A	
K8AC-H□2		2.00 to 22.00 A		10.00 A		
K8AC-H□3		20.0 to 200.0 A		100.0 A		
Voltage Fluctuation Compensation Standard Value	Sets the standard voltage used by the voltage fluctuation compensation function. The fluctuation compensation function operates in respect to this set value.	VFU	100 to 240 VAC	100 V		
Set Mode	All Initialization	Returns all set values and measurement values to their default settings.	UNZ	ON/OFF	OFF	
	Set Value Initialization	Returns all set values to their default settings.	SUN	ON/OFF	OFF	
	Processing Value Initialization	Returns all measurement values to their default settings.	PUN	ON/OFF	OFF	
	Alarm Hysteresis 1	Sets hysteresis for the alarm output value for burnout detection (undercurrent) and heater layer short circuits (overcurrent) for CT1.	HY51	1 to 999	10	
	Alarm Hysteresis 2	Sets hysteresis for the alarm output value for burnout detection (undercurrent) and heater layer short circuits (overcurrent) for CT2.	HY52	1 to 999	10	
	Gate Input Function	Turns the gate input function ON and OFF. If the gate input is turned OFF, application as a simple ammeter is possible.	GRE	ON/OFF	ON	
	Voltage Fluctuation Compensation Reference Value	Turns the voltage fluctuation compensation function ON and OFF.	UDP	ON/OFF	OFF	
	Startup Lock Time	Sets the lock time for the startup lock.	SEUN	0 (OFF) to 255 s	0 (OFF)	
	Output ON-Delay	Sets the output delay time. Set this parameter to set the operating time.	ODLY	0.0 (OFF) to 99.9 s	0.0 (OFF)	
	Soft Startup Time	Sets the soft startup time. Set this parameter only when using a soft start function with the power regulator.	SOF	0.0 (OFF) to 99.9 s	0.0 (OFF)	
	SSR Short Circuit Detection	Turns the SSR short circuit detection function ON and OFF.	SSH	ON/OFF	OFF	
	SSR Open Circuit Detection	Turns the SSR open circuit detection function ON and OFF.	SOP	ON/OFF	OFF	
	Heater Layer Short Circuit Detection (Overcurrent Detection)	Turns the heater layer short circuit (overcurrent) detection function ON and OFF.	HrSH	ON/OFF	OFF	
	Heater Layer Short Circuit Alarm Level (Overcurrent Alarm Set Value)	K8AC-H□1 K8AC-H□2 K8AC-H□3	Sets the operating level for heater layer short circuit (overcurrent) alarms. The heater layer short circuit alarm level is the same for both CT1 and CT2.	HrRL	0.200 to 2.200 A	2.000 A
					2.00 to 22.00 A	20.00 A
					20.0 to 200.0 A	200.0 A
	Heater Control Method *1	Sets the control method of the cyclic/phase control heater.	NSND	PH1, PH3, CYCL	PH1	
	Switchable Display	Sets the CT for which to normally display the current.	DSL	CT1, CT2	CT1	
	Power Save Mode	Turns entering the power save mode ON and OFF.	PSND	ON/OFF	OFF	
	Power Save Mode Standby Time	Sets the time to enter power save mode.	PSUN	10 to 300 s	60 s	
	Display Mode	Sets a 7-segment (NORM), full-span comparison (CMP), or bar (BAR) display.	DSND	NORM, CMP, BAR	NORM	
	Display Refresh Time	Sets the refresh time for the display.	DSRF	0.2 s, 0.5 s, 1.0 s, FAST	0.5 s	
	Unit Number	Sets the unit number for RS-485 communications.	UNO	0 to 64	0	
	Baud Rate	Sets the baud rate for RS-485 communications.	DRS	1200, 2400, 4800, 9600, 19200	9600	
	Data Length	Sets the data length for RS-485 communications.	LEN	7, 8	7	
	Stop Bits	Sets the number of stop bits for RS-485 communications.	SbL	1, 2	2	
	Parity Bit	Sets the parity for RS-485 communications.	PrLY	EVEN, ODD, NONE	EVEN	
	Gate OFF output hold time *2	Sets the time from when the gate signal goes OFF until the burnout alarm output turns OFF.	UDH	0 to 999 s	2 s	
	Number of CT passes 1	Sets the number of times the conductor for CT1 is passed through the current transformer.	CTI	1 to 99 times	1 time	
	CT Ratio 1	Sets the CT ratio for CT1.	CTR1	1 to 999	1	
	Setting 1 for number of effective digits to be displayed after the decimal point	Sets the number of effective digits to be displayed after the decimal point for the CT1 current display.	NDP1	0 to 3 places	Depends on the model.	
	Number of CT passes 2	Sets the number of times the conductor for CT2 is passed through the current transformer.	CT2	1 to 99 times	1 time	
CT Ratio 2	Sets the CT ratio for CT2.	CTR2	1 to 999	1		
Setting 2 for number of effective digits to be displayed after the decimal point	Sets the number of effective digits to be displayed after the decimal point for the CT2 current display.	NDP2	0 to 3 places	Depends on the model.		

Item Mode	Parameter name	Description	Parameter	Setting range	Default
Set Mode	SSR ON delay	Sets the SSR ON-delay time.	SSR _{ON}	0.0 (OFF) to 99.9 s	0.2 s
	SSR operation gate current level	Sets the gate current level for SSR operation. (This setting is valid only when cyclic or phase control is selected as the heater control method.)	SSR _{LEV}	4.0 to 20 mA	7.0 mA
	Cycle time *3	Sets the cycle time. (This setting is valid only when cyclic control is selected as the heater control method.)	CYCLE	0.2 to 3.0 s	0.2 s
Gate Mode	Gate Current Level *1	Sets the gate current value that stops an alarm, detection, or output.	G-LEV	7.0 to 20.0 mA	7.0 mA

*1. Displayed by the K8AC-H□□P□-FLK.

*2. Displayed by the K8AC-H□□C□-FLK.

*3. You must restart the K8AC after you change the setting of the cycle time.

Dimensions

(Unit: mm)

Digital Heater Element Burnout Detectors

K8AC-H2□□□-FLK

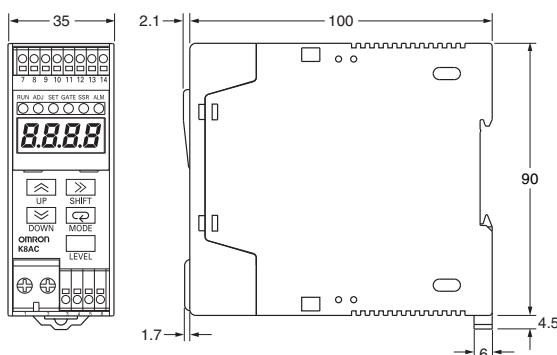

To remove a wire, insert the recommended flat-blade screwdriver straight into the hole under the push-in terminal of the wire to enable easy removal.

K8AC-H1□□□-FLK

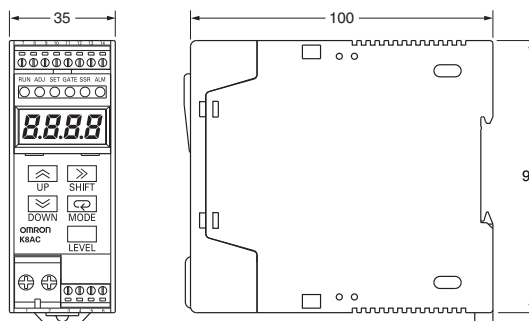

Recommended Tools

Recommended Flat-blade Screwdriver

Manufacturer: Phoenix Contact

Model number: SZF0.4 × 2.5

Crimper for Bar Terminals (Crimping Tool)

Manufacturer: Phoenix Contact

Model number: CRIMPF0X UD6

Recommended power line diameters: AWG10 to AWG24

Recommended Crimp Terminals

Terminals	Recommended crimp terminals	Recommended wire gauge
1 and 2	M3 crimp terminals (Width: 5.8 mm max.) 	AWG16 to AWG18
3 to 14	M2 bar terminals: AI 0.34-8TQ (Phoenix Contact) M2 bar terminals: AI 0.5-8WH (Phoenix Contact) M2 bar terminals: AI 0.75-8GY (Phoenix Contact)	AWG22 AWG20 AWG18

Note: Securely tighten the terminal screws to the following torque:
Power supply terminals: 0.5 N·m
I/O terminals: 0.23 N·m

K8AC-H

Optional Parts (Sold Separately)

Current Transformer K8AC-CT20S

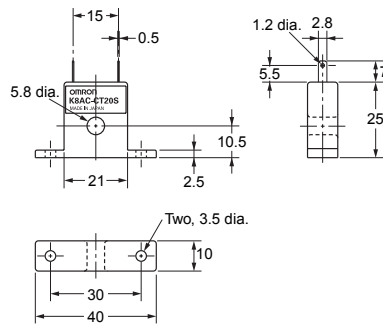

Current Transformer K8AC-CT20L

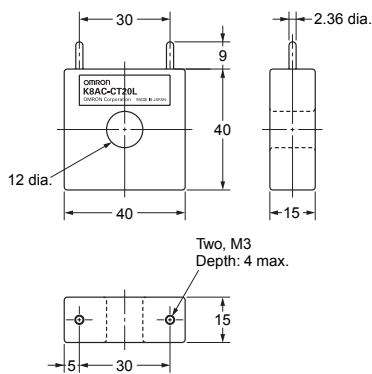

Accessories with K8AC-CT20L: Connection Example Contact

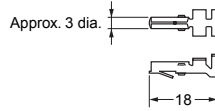

Plug

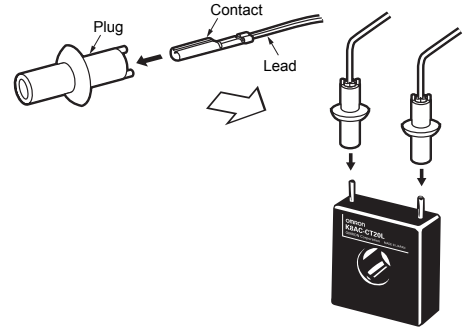

Current Transformer K8AC-CT200 (Pre-wired Leads)

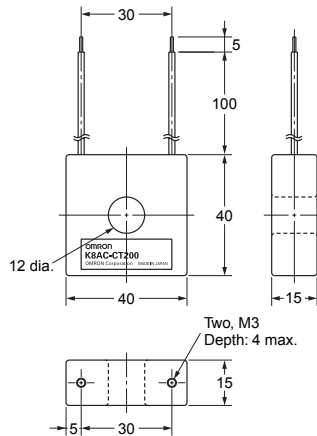

Current Transformer K8AC-CT200L

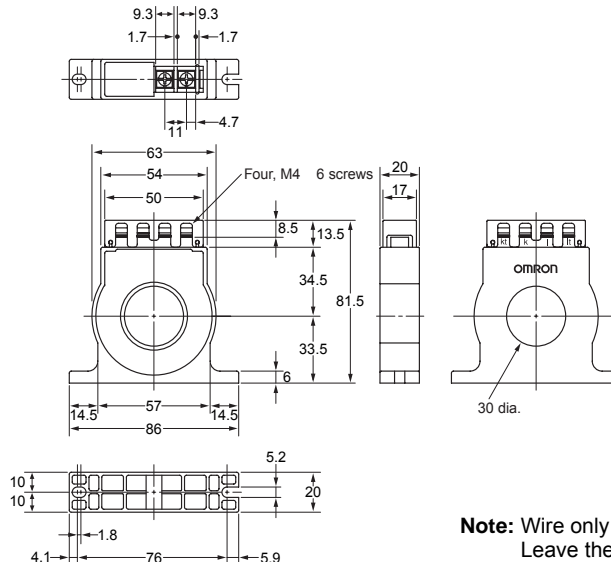

Mounting Hole Dimensions

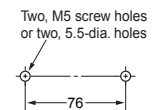

Note: Wire only the K and L terminals to the K8AC-H. Leave the Kt and Lt terminals open.

Safety Precautions

Precautions for Safe Use

The following precautions are essential to ensure safety. Always heed these precautions.

- Do not use or store the Product in the following locations.
 - Outdoors or in locations subject to direct sunlight, wind, or rain
 - Locations subject to dust, metal powder, or corrosive gases (in particular, sulfuric or ammonia gas)
 - Locations subject to static electricity or noise
 - Locations subject to flooding or exposure to oil
- Use DIN Track for installation and mount the Product in the correct direction.
- Do not touch the terminals when power is being supplied. Electric shock may occasionally occur.
- Be sure you understand the contents of the Instruction Sheet and User's Manual and handle the Product according to the instructions provided.
- Check all terminal numbers and polarity when wiring and wire all connections correctly.
- Tighten terminal screws to the following torque.
 - Power supply terminals: 0.5 N·m
- Use the Product within the specified temperature and humidity ranges.
- Do not use the product in locations subject to flammable or explosive gases. Explosions may occasionally occur if the product is used in such locations.
- Do not install the Product in any way that would place a load on it.
- Use the Current Transformer specified by OMRON.
- Install an external switch or circuit breaker that complies with applicable IEC60947-1 and IEC60947-3 requirements and label it clearly so that the operator can quickly turn OFF the power.
- The product must be handled by personnel who have knowledge of electrical systems.

Precautions for Correct Use

The following precautions are essential to ensure correct use. Always heed these precautions.

- Do not use the product in the following locations.
 - Places subject to radiant heat from heat generating devices.
 - Places subject to vibrations or physical shocks.
- Make sure to use setting values appropriate for the controlled object. Failure to do so can cause unintended operation, and may result in accident or corruption of the product.
- Do not use thinner or similar solvent for cleaning. Use commercial alcohol.
- When discarding, properly dispose of the product as industrial waste.
- To measure correct values, perform aging for approximately 15 minutes.
- Only use this product within a board whose structure allows no possibility for fire to escape.

Installation

- When wiring, use only recommended crimp terminals.
- Do not block areas around the product for proper dissipation of heat. (If you do not secure space for heat dissipation, life cycle of the product will be compromised.)

Mounting the K8AC-H

- Pull down the hook on the bottom of the K8AC-H, and then catch the hook on the top of the K8AC-H onto the DIN Track and press the K8AC-H onto the DIN Track until it locks into place.

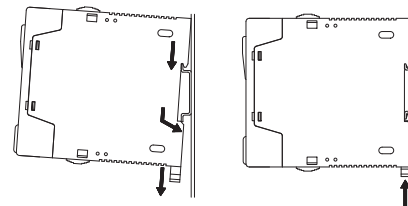

Removing the K8AC-H

- Pull down on the hook with a flat-blade screwdriver and lift up on the K8AC-H.

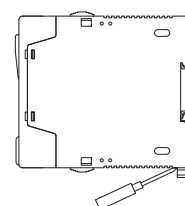

Noise Countermeasures

- Do not install the product near devices generating strong high frequency waves or surges.
- When using a noise filter, check the voltage and current and install it as close to the product as possible.
- In order to prevent inductive noise, wire the lines connected to the product separately from power lines carrying high voltages or currents. Do not wire in parallel with or on the same cable as power lines.
 - Other measures for reducing noise include running lines along separate ducts and using shield lines.

Wiring

- Do not touch terminals or perform wiring while power is supplied to the product. Doing so may result in injury or malfunction.
- Wire to the correct terminal number. Incorrect wiring may result in damage to or burning of components.

Wiring the Push-in Terminals

- Directly insert the ferrule in the hole of the terminal to be wired.

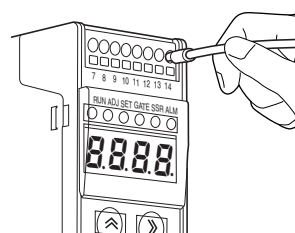

Removing Wires from the Push-in Terminals

- Insert the recommended flat-blade screwdriver straight into the hole to pull out the wire.

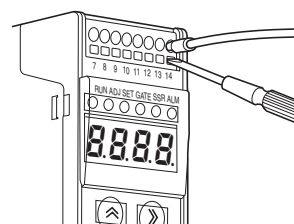

Q & A

Q Why does the current measured by the K8AC-H decrease during cyclic or phase control?

A To enable measuring the current accurately for the heater control value, the K8AC-H□□P□-FLK uses the current input waveform from a gate input and the Current Transformer to compensate the measured current value and burnout alarm value. The compensated current value is displayed, so it appears as if the measured current is lower during cyclic or phase control, but the K8AC-H□□P□-FLK is operating correctly.

Q How do I set the burnout detection alarm of the K8AC-H□□P□-FLK when phase control is used?

A Set the burnout alarm value of the K8AC-H□□P□-FLK based on the current measurement value with the heater output at 100%. (This is because the burnout detection alarm of the K8AC-H□□P□-FLK depends on the control input.) When you set the burnout alarm value, make sure that you make the setting based on the current measurement value when the control of the power regulator is 100% or the rated voltage is applied to the heater.

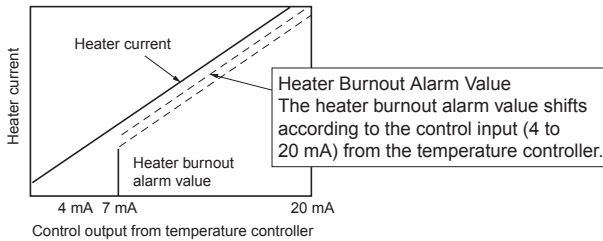

Warranty and Application Considerations

Warranty and Limitations of Liability

WARRANTY

OMRON's exclusive warranty is that the products are free from defects in materials and workmanship for a period of one year (or other period if specified) from date of sale by OMRON.

OMRON MAKES NO WARRANTY OR REPRESENTATION, EXPRESS OR IMPLIED, REGARDING NON-INFRINGEMENT, MERCHANTABILITY, OR FITNESS FOR PARTICULAR PURPOSE OF THE PRODUCTS. ANY BUYER OR USER ACKNOWLEDGES THAT THE BUYER OR USER ALONE HAS DETERMINED THAT THE PRODUCTS WILL SUITABLY MEET THE REQUIREMENTS OF THEIR INTENDED USE. OMRON DISCLAIMS ALL OTHER WARRANTIES, EXPRESS OR IMPLIED.

LIMITATIONS OF LIABILITY

OMRON SHALL NOT BE RESPONSIBLE FOR SPECIAL, INDIRECT, OR CONSEQUENTIAL DAMAGES, LOSS OF PROFITS, OR COMMERCIAL LOSS IN ANY WAY CONNECTED WITH THE PRODUCTS, WHETHER SUCH CLAIM IS BASED ON CONTRACT, WARRANTY, NEGLIGENCE, OR STRICT LIABILITY.

In no event shall the responsibility of OMRON for any act exceed the individual price of the product on which liability is asserted.

IN NO EVENT SHALL OMRON BE RESPONSIBLE FOR WARRANTY, REPAIR, OR OTHER CLAIMS REGARDING THE PRODUCTS UNLESS OMRON'S ANALYSIS CONFIRMS THAT THE PRODUCTS WERE PROPERLY HANDLED, STORED, INSTALLED, AND MAINTAINED AND NOT SUBJECT TO CONTAMINATION, ABUSE, MISUSE, OR INAPPROPRIATE MODIFICATION OR REPAIR.

Application Considerations

SUITABILITY FOR USE

OMRON shall not be responsible for conformity with any standards, codes, or regulations that apply to the combination of products in the customer's application or use of the products.

Take all necessary steps to determine the suitability of the product for the systems, machines, and equipment with which it will be used.

Know and observe all prohibitions of use applicable to this product.

NEVER USE THE PRODUCTS FOR AN APPLICATION INVOLVING SERIOUS RISK TO LIFE OR PROPERTY WITHOUT ENSURING THAT THE SYSTEM AS A WHOLE HAS BEEN DESIGNED TO ADDRESS THE RISKS, AND THAT THE OMRON PRODUCTS ARE PROPERLY RATED AND INSTALLED FOR THE INTENDED USE WITHIN THE OVERALL EQUIPMENT OR SYSTEM.

Disclaimers

CHANGE IN SPECIFICATIONS

Product specifications and accessories may be changed at any time based on improvements and other reasons. Consult with your OMRON representative at any time to confirm actual specifications of purchased product.

DIMENSIONS AND WEIGHTS

Dimensions and weights are nominal and are not to be used for manufacturing purposes, even when tolerances are shown.

Related Products



Heater Element Burnout Detector **K2CU**

Enables detection of single-phase/three-phase burnouts.
For heaters with ON/OFF control only, provides voltage fluctuation compensation.
Rated current: 0.25 to 80 A AC



Current Sensor **SAO**

Enables detection of single-phase/three-phase overcurrents.
Inverse operation models and instantaneous operation models (with startup lock) are available.
Rated current: 1 to 160 A AC

For details, refer to the *Measuring & Motor Protective Relays Group Catalog* (Cat. No. X070).

- The application examples provided in this catalog are for reference only. Check functions and safety of the equipment before use.
- Never use the products for any application requiring special safety requirements, such as nuclear energy control systems, railroad systems, aviation systems, medical equipment, amusement machines, vehicles, safety equipment, or other application involving serious risk to life or property, without ensuring that the system as a whole has been designed to address the risks, and that the OMRON products are properly rated and installed for the intended use within the overall equipment or system.

ALL DIMENSIONS SHOWN ARE IN MILLIMETERS.

To convert millimeters into inches, multiply by 0.03937. To convert grams into ounces, multiply by 0.03527.

OMRON Corporation Industrial Automation Company
Tokyo, JAPAN

Contact: www.ia.omron.com

Regional Headquarters

OMRON EUROPE B.V.

Wegalaan 67-69-2132 JD Hoofddorp
The Netherlands
Tel: (31)2356-81-300/Fax: (31)2356-81-388

OMRON ASIA PACIFIC PTE. LTD.

No. 438A Alexandra Road # 05-05/08 (Lobby 2),
Alexandra Technopark,
Singapore 119967
Tel: (65) 6835-3011/Fax: (65) 6835-2711

OMRON ELECTRONICS LLC

One Commerce Drive Schaumburg,
IL 60173-5302 U.S.A.
Tel: (1) 847-843-7900/Fax: (1) 847-843-7787

OMRON (CHINA) CO., LTD.

Room 2211, Bank of China Tower,
200 Yin Cheng Zhong Road,
PuDong New Area, Shanghai, 200120, China
Tel: (86) 21-5037-2222/Fax: (86) 21-5037-2200

Authorized Distributor:

© OMRON Corporation 2009 All Rights Reserved.
In the interest of product improvement,
specifications are subject to change without notice.

CSM_8_4_0815

Cat. No. N137-E1-03

Printed in Japan
0508

Mouser Electronics

Authorized Distributor

Click to View Pricing, Inventory, Delivery & Lifecycle Information:

[Omron:](#)

[K8AC-CT200L](#)

Компания «Океан Электроники» предлагает заключение долгосрочных отношений при поставках импортных электронных компонентов на взаимовыгодных условиях!

Наши преимущества:

- Поставка оригинальных импортных электронных компонентов напрямую с производств Америки, Европы и Азии, а так же с крупнейших складов мира;
- Широкая линейка поставок активных и пассивных импортных электронных компонентов (более 30 млн. наименований);
- Поставка сложных, дефицитных, либо снятых с производства позиций;
- Оперативные сроки поставки под заказ (от 5 рабочих дней);
- Экспресс доставка в любую точку России;
- Помощь Конструкторского Отдела и консультации квалифицированных инженеров;
- Техническая поддержка проекта, помощь в подборе аналогов, поставка прототипов;
- Поставка электронных компонентов под контролем ВП;
- Система менеджмента качества сертифицирована по Международному стандарту ISO 9001;
- При необходимости вся продукция военного и аэрокосмического назначения проходит испытания и сертификацию в лаборатории (по согласованию с заказчиком);
- Поставка специализированных компонентов военного и аэрокосмического уровня качества (Xilinx, Altera, Analog Devices, Intersil, Interpoint, Microsemi, Actel, Aeroflex, Peregrine, VPT, Syfer, Eurofarad, Texas Instruments, MS Kennedy, Miteq, Cobham, E2V, MA-COM, Hittite, Mini-Circuits, General Dynamics и др.);

Компания «Океан Электроники» является официальным дистрибьютором и эксклюзивным представителем в России одного из крупнейших производителей разъемов военного и аэрокосмического назначения «**JONHON**», а так же официальным дистрибьютором и эксклюзивным представителем в России производителя высокотехнологичных и надежных решений для передачи СВЧ сигналов «**FORSTAR**».



JONHON

«**JONHON**» (основан в 1970 г.)

Разъемы специального, военного и аэрокосмического назначения:

(Применяются в военной, авиационной, аэрокосмической, морской, железнодорожной, горно- и нефтедобывающей отраслях промышленности)

«**FORSTAR**» (основан в 1998 г.)

ВЧ соединители, коаксиальные кабели,
кабельные сборки и микроволновые компоненты:

(Применяются в телекоммуникациях гражданского и специального назначения, в средствах связи, РЛС, а так же военной, авиационной и аэрокосмической отраслях промышленности).



Телефон: 8 (812) 309-75-97 (многоканальный)

Факс: 8 (812) 320-03-32

Электронная почта: ocean@oceanchips.ru

Web: <http://oceanchips.ru/>

Адрес: 198099, г. Санкт-Петербург, ул. Калинина, д. 2, корп. 4, лит. А