

| REVISONS | | DATE | BY | APPV |
|----------|-----------------------|--------|----|------|
| F | LTR | | | |
| G | REV PER ECO 13-018917 | 2-3-14 | CT | KH |

SQUARE FLANGE MOUNT RECEPTACLES:



SHELL ALTERNATE KEYING POSITIONS:

IN THE "ALTERNATE KEYING POSITION" (POSITION 6,7,8,9, AND 10), THE KEYS ARE POSITIONED AS INDICATED IN THE CHART BELOW WITH REFERENCE TO MASTER KEY. WHEN THE ALTERNATE SHELL KEYING POSITIONS ARE USED, THE APPLICABLE INSERT IS ALWAYS IN THE NORMAL POSITION.

KEY / KEYWAY LOCATIONS

| KEYING POSITION | SIZE 12 THRU 24 | | | |
|-----------------|-----------------|-----|-----|-----|
| | A° | B° | C° | D° |
| NORMAL | 105 | 140 | 215 | 265 |
| 6 | 18 | 149 | 192 | 259 |
| 7 | 92 | 152 | 222 | 342 |
| 8 | 84 | 152 | 204 | 334 |
| 9 | 24 | 135 | 199 | 240 |
| 10 | 98 | 152 | 268 | 338 |

| SHELL SIZE | A | B | C | D | E | F | G | H | J | K | L | N | E° | F° | G° |
|------------|-------|----------------|----------------|-------|-------|-------|-------|-------|-------|-------|------|-------------------|----|-----|-----|
| 12 | .558 | .705 .700 | .829 .824 | .875 | .613 | .687 | .750 | .812 | 1.031 | .913 | .120 | 3/4-20 UNEF-2A | 50 | 170 | 290 |
| 14 | .627 | .774 .769 | .898 .893 | .935 | .738 | .812 | .875 | .906 | 1.125 | .980 | | 7/8-20 UNEF-2A | | | |
| 16 | .772 | .901 .896 | 1.025 1.020 | 1.062 | .863 | .937 | 1.000 | .969 | 1.250 | 1.107 | | 1-20 UNEF-2A | | | |
| 18 | .860 | 1.007 1.002 | 1.131 1.126 | 1.187 | .919 | .992 | 1.062 | 1.062 | 1.343 | 1.209 | | 1 1/16-18 UNEF-2A | | | |
| 20 | .985 | 1.132 1.127 | 1.256 1.251 | 1.312 | 1.044 | 1.117 | 1.187 | 1.156 | 1.437 | 1.337 | .120 | 1 3/16-18 UNEF-2A | | | |
| 24 | 1.235 | 1.382 1.377 | 1.506 1.501 | 1.562 | 1.294 | 1.367 | 1.437 | 1.375 | 1.703 | 1.577 | .149 | 1 7/16-18 UNEF-2A | 50 | 170 | 290 |

METRIC EQUIVALENT MM

| SHELL SIZE | A | B | C | D | E | F | G | H | J | K | L |
|------------|--------|------------------|------------------|--------|--------|--------|--------|--------|--------|--------|-------|
| 12 | 14.173 | 17.907 17.778 | 21.057 20.930 | 22.225 | 15.570 | 17.450 | 19.050 | 20.625 | 26.187 | 23.190 | 3.048 |
| 14 | 15.926 | 19.660 19.533 | 22.809 22.682 | 23.749 | 18.745 | 20.625 | 22.225 | 23.012 | 28.575 | 24.892 | |
| 16 | 19.609 | 22.889 22.760 | 26.035 25.908 | 26.975 | 21.920 | 23.800 | 25.400 | 24.613 | 31.750 | 28.118 | |
| 18 | 21.844 | 25.578 25.451 | 28.727 28.600 | 30.150 | 23.343 | 25.197 | 26.975 | 26.975 | 34.112 | 30.709 | |
| 20 | 25.019 | 28.753 28.626 | 31.902 31.775 | 33.325 | 26.518 | 28.372 | 30.150 | 29.362 | 36.500 | 33.960 | 3.048 |
| 24 | 31.369 | 35.103 34.976 | 38.252 38.125 | 39.765 | 32.868 | 34.722 | 36.500 | 34.925 | 43.256 | 40.056 | 3.785 |

| PART NUMBER | WEIGHT in Grams Nominal |
|---------------|-------------------------|
| RD10A-12-08PX | 15.58 |
| RD10A-12-08SX | TBD |
| RD10A-14-12PX | 18.71 |
| RD10A-14-12SX | TBD |
| RD10A-16-19PX | 21.96 |
| RD10A-16-19SX | TBD |
| RD10A-18-23PX | 24.97 |
| RD10A-18-23SX | TBD |
| RD10A-20-31PX | 28.55 |
| RD10A-20-31SX | TBD |
| RD10A-24-51PX | TBD |
| RD10A-24-51SX | TBD |

| CABLE TYPE | PIN | SOCKET |
|--------------|----------|----------|
| COAX | D-602-44 | D-602-45 |
| TWISTED PAIR | D-602-54 | D-602-55 |
| PRIMARY WIRE | D-610-09 | D-610-10 |

PART NUMBER IDENTIFICATION:

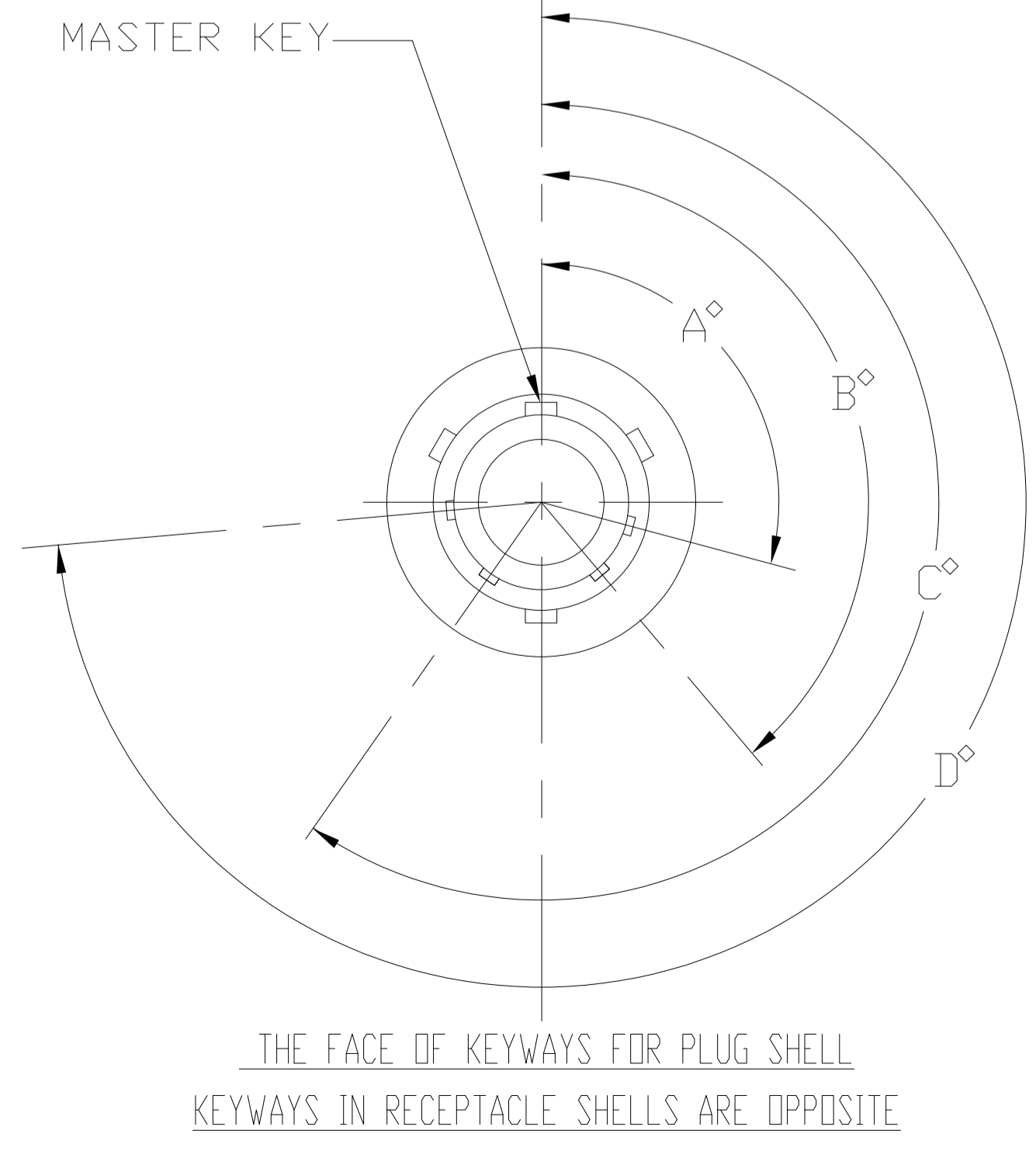
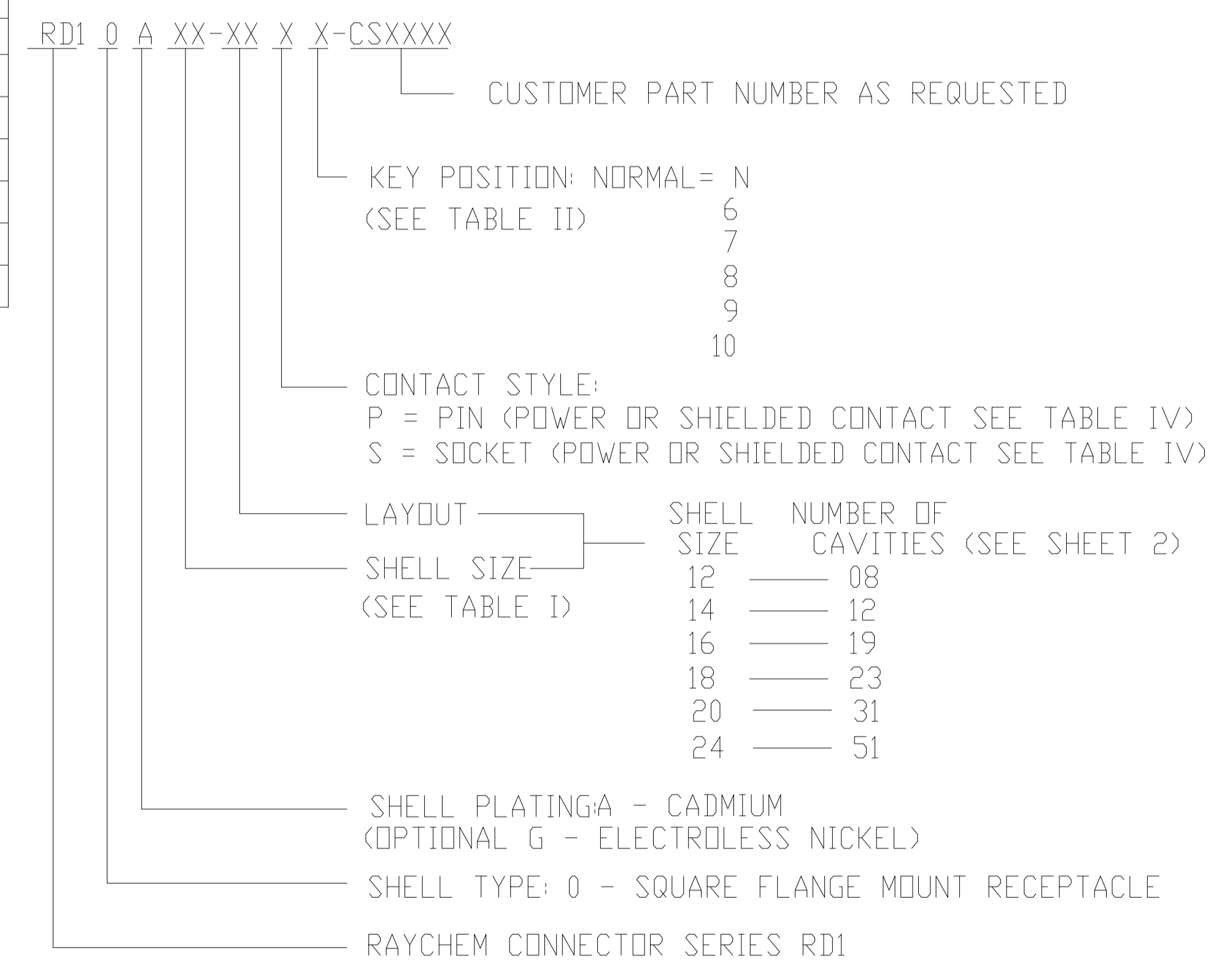

THIS DRAWING IS A CONTROLLED DOCUMENT. DIN C.C.THOMAS 03FEB2014

TE Connectivity

RD1 SERIES CONNECTOR, RECEPTACLE

RD10AXX-XXP/SX

SCALE: NTS SHEET 1 OF 3 REV G

| LOC | | DIST | | REVISIONS | | | |
|-----|-----|-------------|------|-----------|------|---|---|
| P | LTR | DESCRIPTION | DATE | DN | APVD | | |
| - | - | SEE SHEET 1 | - | - | - | - | - |

▼
SYM. ABOUT VERTICAL INSERT CENTER LINE ONLY



12-08
8 #16 CAVITIES

▼
SYM. ABOUT VERTICAL INSERT CENTER LINE ONLY

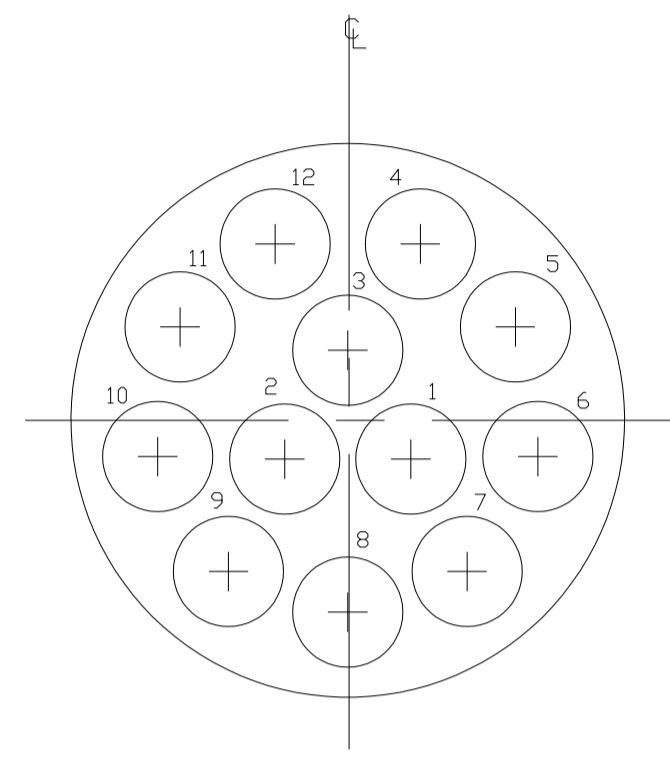

14-12
12 #16 CAVITIES

▼
SYM. ABOUT INSERT CENTER LINE

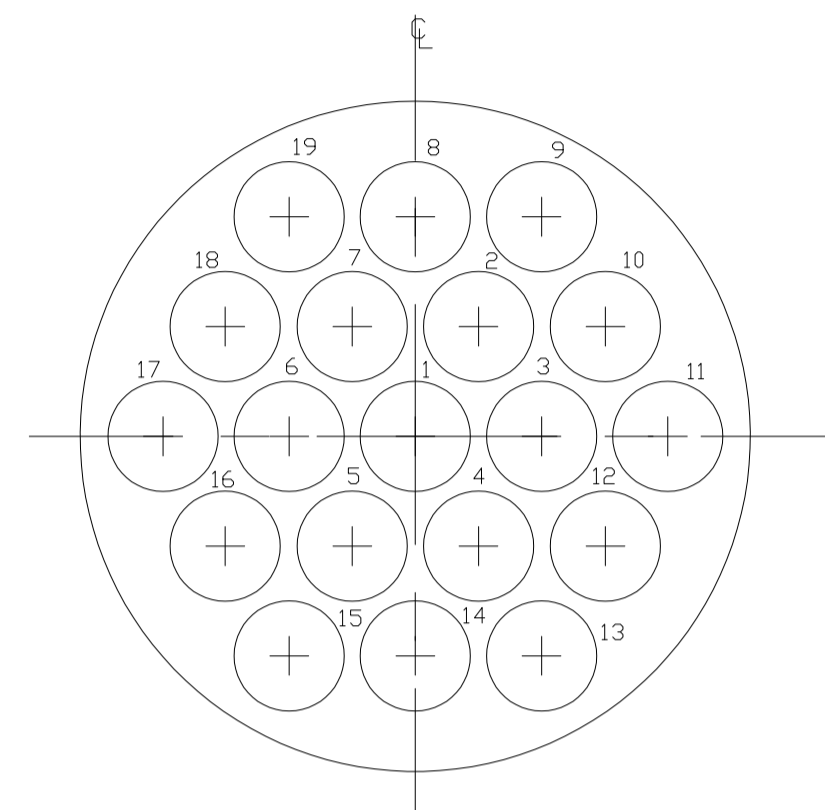

16-19
19 #16 CAVITIES

▼
SYM. ABOUT INSERT CENTER LINE



18-23
23 #16 CAVITIES

▼
SYM. ABOUT INSERT CENTER LINE



20-31
31 #16 CAVITIES

▼
SYM. ABOUT VERTICAL INSERT CENTER LINE ONLY



24-51
51 #16 CAVITIES

1. FULLY MATED COUPLING STRIPES SHALL BE COLOR CODED BLUE IN LINE WITH THE BAYONET PINS ON THE RECEPTACLE SHELL.
2. MATERIAL: METAL PARTS, EXCLUSIVE OF BAYONET PINS, COUPLING RING SPRING SHALL BE HIGH GRADE ALUMINUM ALLOY CONFORMING TO ASTM B 211 / SAE AMS-QQ-A 225/10. BAYONET PINS AND COUPLING RING SPRING SHALL BE STAINLESS STEEL.
3. INSERT MATERIAL-MINERAL FILLED PHENDLIC PER ASTM-D5948, TYPE MFH
4. CONNECTOR IDENTIFICATION SHALL CONSIST OF NAME RAYCHEM, TE CONNECTIVITY PART NUMBER, MIS DESCRIPTION (PER TABLE V) AND THE LOT CONTROL NO. OR DATE CODE. ALL CHARACTERS SHALL BE A MINIMUM OF 1/32" IN HEIGHT AND SHALL BE PERMANENTLY AND LEGIBLY MARKED IN LOCATIONS SHOWN. MARKING SHALL BE WITHIN 265° CIRCUMFERENCE. MARKING SHALL BE READ FROM THE MATING FACE UP FOR THE PLUG AND MATING FACE DOWN FOR THE RECEPTACLE.
5. CAVITY IDENTIFICATION NUMBERS SHALL BE AS LARGE AS POSSIBLE, OF A CONTRASTING COLOR, AND LOCATED APPROXIMATELY AS SHOWN.
6. CONTACT IDENTIFICATION IS SHOWN BY LOOKING AT FRONT PIN INSERT FACE. FRONT SOCKET INSERT FACE IS OPPOSITE. REAR PIN INSERT FACE IS OPPOSITE. REAR SOCKET INSERT FACE IS AS SHOWN.
7. ▼ INDICATES SHELL MASTER KEY OR KEYWAY POSITION.
8. SHELL PLATING: CADMIUM PER SAE AMS-QQ-P 416, TYPE II, CLASS 3, .0002/.0005 INCH, OLIVE DRAB, CONDUCTIVE OVER .0002/.0004 INCH ELECTROLESS NICKEL PLATE PER SAE AMS 2404
9. THESE DIMENSIONS ARE SHOWING THE POSITION OF THE PIN AND SOCKET CONTACTS.
10. THIS PRODUCT IS QUALIFIED TO TYCO ELECTRONICS SPECIFICATION D-6001 PER TEST REPORT TR3-6540-001.

| | | | | |
|--|--|--------------------------------|--|---------------|
| THIS DRAWING IS A CONTROLLED DOCUMENT. | | DIN C.C.THOMAS 03FEB2014 | STE TE Connectivity | |
| DIMENSIONS: INCHES | | CHK K.HOGAN 2-3-14 | NAME RDI SERIES CONNECTOR, RECEPTACLE | |
| TOLERANCES UNLESS OTHERWISE SPECIFIED: 0. PLC ± - 1. PLC ± - 2. PLC ± .01 [0.3] 3. PLC ± .005 [0.13] 4. PLC ± - ± 1' ANGLES ± - ± 1' | | APVD K.HOGAN 2-3-14 | PRODUCT SPEC | |
| MATERIAL | | APPLICATION SPEC | SIZE A1 | RESTRICTED TO |
| FINISH | | WEIGHT SEE TABLE III | CAGE CODE RD10AXX-XXP/SX | SCALE NTS |
| CUSTOMER DRAWING | | DATE 000779 | SHEET 2 OF 3 | REV G |

THIS DRAWING IS UNPUBLISHED. RELEASED FOR PUBLICATION
 © COPYRIGHT - By - ALL RIGHTS RESERVED.

| LOC | | DIST | | REVISIONS | | | |
|-----|-----|-------------|------|-----------|------|---|---|
| P | LTR | DESCRIPTION | DATE | DN | APVD | | |
| - | - | SEE SHEET 1 | - | - | - | - | - |

| TABLE V | | |
|----------------|-----------------|------------|
| PART NUMBER | MIS DESCRIPTION | RPN |
| RD10A12-08-PN | MIS-20065/1-001 | 056815-000 |
| RD10A12-08-P6 | MIS-20065/1-002 | 827981-000 |
| RD10A12-08-P7 | MIS-20065/1-003 | 143129-000 |
| RD10A12-08-P8 | MIS-20065/1-004 | 600243N007 |
| RD10A12-08-P9 | MIS-20065/1-005 | N/A |
| RD10A12-08-P10 | MIS-20065/1-006 | N/A |
| | | |
| RD10A14-12-PN | MIS-20065/1-007 | 600246N009 |
| RD10A14-12-P6 | MIS-20065/1-008 | 600247N007 |
| RD10A14-12-P7 | MIS-20065/1-009 | 600248N007 |
| RD10A14-12-P8 | MIS-20065/1-010 | 600249N006 |
| RD10A14-12-P9 | MIS-20065/1-011 | 330035-000 |
| RD10A14-12-P10 | MIS-20065/1-012 | 539255-000 |
| | | |
| RD10A16-19-PN | MIS-20065/1-013 | 600252N009 |
| RD10A16-19-P6 | MIS-20065/1-014 | 600253N007 |
| RD10A16-19-P7 | MIS-20065/1-015 | 429283-000 |
| RD10A16-19-P8 | MIS-20065/1-016 | 600255N006 |
| RD10A16-19-P9 | MIS-20065/1-017 | 182749-000 |
| RD10A16-19-P10 | MIS-20065/1-018 | 112055-000 |
| | | |
| RD10A18-23-PN | MIS-20065/1-019 | 600258N009 |
| RD10A18-23-P6 | MIS-20065/1-020 | 600259N006 |
| RD10A18-23-P7 | MIS-20065/1-021 | 936753-000 |
| RD10A18-23-P8 | MIS-20065/1-022 | 600261N005 |
| RD10A18-23-P9 | MIS-20065/1-023 | 600262N004 |
| RD10A18-23-P10 | MIS-20065/1-024 | N/A |
| | | |
| RD10A20-31-PN | MIS-20065/1-025 | 600264N008 |
| RD10A20-31-P6 | MIS-20065/1-026 | 600265N008 |
| RD10A20-31-P7 | MIS-20065/1-027 | 600266N007 |
| RD10A20-31-P8 | MIS-20065/1-028 | 600267N007 |
| RD10A20-31-P9 | MIS-20065/1-029 | 600268N005 |
| RD10A20-31-P10 | MIS-20065/1-030 | N/A |
| | | |
| RD10A24-51-PN | MIS-20065/1-031 | 600270N009 |
| RD10A24-51-P6 | MIS-20065/1-032 | 600271N009 |
| RD10A24-51-P7 | MIS-20065/1-033 | 412579-000 |
| RD10A24-51-P8 | MIS-20065/1-034 | 600273N007 |
| RD10A24-51-P9 | MIS-20065/1-035 | 600274N006 |
| RD10A24-51-P10 | MIS-20065/1-036 | 600275N005 |

NOTE: ALL CONNECTORS LISTED ON TABLE V ARE MEETING THE REQUIREMENTS OF CS051/1. PARTS ARE MARKED WITH PART NUMBER AND MIS DESCRIPTION. THE CS051/1 PORTION OF THE PART NUMBER IDENTIFICATION IS NOT INCLUDED IN THE PART NUMBER MARKING.

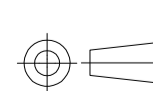
| | | | | | |
|---|--|--|--|---|--|
| THIS DRAWING IS A CONTROLLED DOCUMENT. | | DIN C.C.THOMAS 05FEB2014 | |  TE Connectivity | |
| DIMENSIONS: INCHES | | TOLERANCES UNLESS OTHERWISE SPECIFIED: | | | |
|  | | 0. PLC ± - 1. PLC ± - 2. PLC ± .01 [0.3] 3. PLC ± .005 [0.13] 4. PLC ± - ± 1° ANGLES ± - ± 1° | | NAME RDI SERIES CONNECTOR, RECEPTACLE APPLICATION SPEC | |
| MATERIAL | | FINISH | | WEIGHT SEE TABLE III A1 00779 RD10AXX-XXP/SX CUSTOMER DRAWING | |
| 4805 (3/11) | | 11:03am | | SCALE NTS SHEET 3 OF 3 REV G | |

Компания «Океан Электроники» предлагает заключение долгосрочных отношений при поставках импортных электронных компонентов на взаимовыгодных условиях!

Наши преимущества:

- Поставка оригинальных импортных электронных компонентов напрямую с производств Америки, Европы и Азии, а так же с крупнейших складов мира;
- Широкая линейка поставок активных и пассивных импортных электронных компонентов (более 30 млн. наименований);
- Поставка сложных, дефицитных, либо снятых с производства позиций;
- Оперативные сроки поставки под заказ (от 5 рабочих дней);
- Экспресс доставка в любую точку России;
- Помощь Конструкторского Отдела и консультации квалифицированных инженеров;
- Техническая поддержка проекта, помощь в подборе аналогов, поставка прототипов;
- Поставка электронных компонентов под контролем ВП;
- Система менеджмента качества сертифицирована по Международному стандарту ISO 9001;
- При необходимости вся продукция военного и аэрокосмического назначения проходит испытания и сертификацию в лаборатории (по согласованию с заказчиком);
- Поставка специализированных компонентов военного и аэрокосмического уровня качества (Xilinx, Altera, Analog Devices, Intersil, Interpoint, Microsemi, Actel, Aeroflex, Peregrine, VPT, Syfer, Eurofarad, Texas Instruments, MS Kennedy, Miteq, Cobham, E2V, MA-COM, Hittite, Mini-Circuits, General Dynamics и др.);

Компания «Океан Электроники» является официальным дистрибьютором и эксклюзивным представителем в России одного из крупнейших производителей разъемов военного и аэрокосмического назначения «JONHON», а так же официальным дистрибьютором и эксклюзивным представителем в России производителя высокотехнологичных и надежных решений для передачи СВЧ сигналов «FORSTAR».



JONHON

«JONHON» (основан в 1970 г.)

Разъемы специального, военного и аэрокосмического назначения:

(Применяются в военной, авиационной, аэрокосмической, морской, железнодорожной, горно- и нефтедобывающей отраслях промышленности)

«FORSTAR» (основан в 1998 г.)

ВЧ соединители, коаксиальные кабели, кабельные сборки и микроволновые компоненты:

(Применяются в телекоммуникациях гражданского и специального назначения, в средствах связи, РЛС, а так же военной, авиационной и аэрокосмической отраслях промышленности).



Телефон: 8 (812) 309-75-97 (многоканальный)

Факс: 8 (812) 320-03-32

Электронная почта: ocean@oceanchips.ru

Web: <http://oceanchips.ru/>

Адрес: 198099, г. Санкт-Петербург, ул. Калинина, д. 2, корп. 4, лит. А