

FEATURES

- Op-amp and Comparator Test Configurations
- AC-coupled configuration
- Fully Assembled and Tested
- 2in x 2in 2-layer circuit board

DESCRIPTION

The demo board for the TS12011/TS12012 is a completely assembled and tested circuit board that can be used for evaluating the TS12011 and TS12012. The TS12011/TS12012 combine a 0.58V reference, a 20 μ s analog comparator, and a unity-gain stable operational amplifier in a single package. Optimized for ultra-long life, single-cell and battery-powered applications, these devices expand Touchstone's growing "NanoWatt Analog™" high-performance analog integrated circuits portfolio.

The TS12011/TS12012 comparator and op-amp circuits are AC-coupled at the input. The op-amp is configured to operate from a single supply voltage from 0.8V to 2.5V while the comparator is configured to operate with a 2.5V single supply voltage. The inverting input of the comparator is connected to a 0.58V internal reference voltage available as REFOUT. The op-amp is configured in a non-inverting and inverting scheme. For additional information, refer to the "Description" section.

Product datasheet and additional documentation can be found on the factory web site at www.touchstonesemi.com.

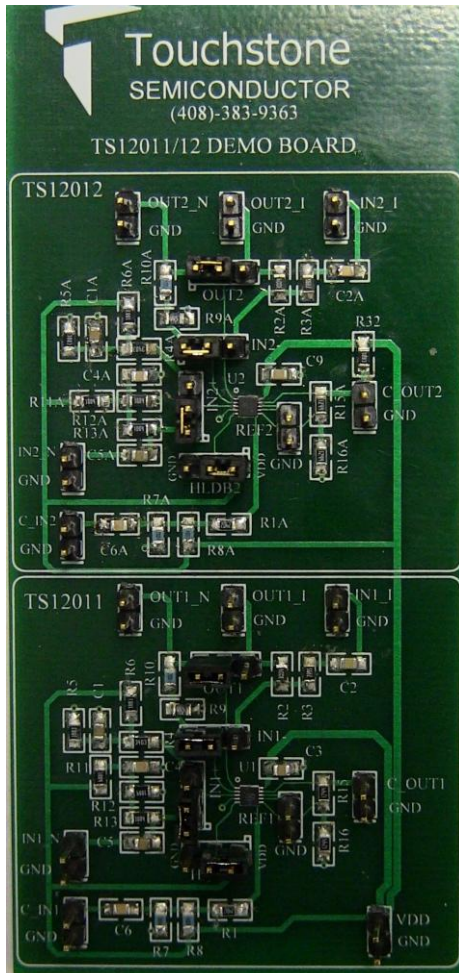

Figure 1. TS12011/TS12012 Evaluation Board

ORDERING INFORMATION

Order Number	Description
TS12011_12DB	TS12011 and TS12012 Demo Board

Description

The TS12011/TS12012 demo board provides two configurations for evaluating the operational amplifier, namely a non-inverting configuration and an inverting configuration. In both cases, the input to each circuit is AC-coupled. The demo board provides a re-biasing scheme at one-half the power supply or $V_{DD}/2$ for the inverting configuration and at $V_{DD}/4$ for the non-inverting configuration. Jumpers are available on the board to switch between configurations. The default configuration is non-inverting.

The TS12011/TS12012 comparator configuration is AC-coupled at the input and is set to operate with a 2.5V single supply voltage. The TS12011/TS12012 has an internal 0.58V reference voltage. This reference voltage is connected to the inverting input of the comparator. The TS12011 has a push-pull output stage while the TS12012 has an open-drain output stage. If evaluation with a different supply voltage and/or additional hysteresis is desired, remove resistor R7, R8, R7A, R8A and capacitor C6 and C6A. Then, create a short between the capacitor pads of C6 and C6A. Please refer to page 7 of the TS12011/TS12012 product datasheet for the design equations necessary.

The TS12011/TS12012 have a latch enable pin ($\overline{\text{LHDET}}$) that is labeled as HLDB on revision 1 of the demo board. LHDET allows the output of the comparator to latch to either a HIGH or LOW state under certain conditions. If $\overline{\text{LHDET}}/\text{HLDB}$ is set HIGH, the COMPOUT output will respond to the applied comparator input. However, when $\overline{\text{LHDET}}/\text{HLDB}$ is set LOW and the TS12011 output is HIGH, COMPOUT will remain HIGH until $\overline{\text{LHDET}}/\text{HLDB}$ toggles LOW. When COMPOUT is initially LOW instead, COMPOUT will latch HIGH and remain HIGH on a LOW-to-HIGH transition at the input of the comparator until $\overline{\text{LHDET}}/\text{HLDB}$ goes HIGH. The TS12012 output is the inverted version of the TS12011 output. The $\overline{\text{LHDET}}/\text{HLDB}$ pin must not be left open and should be connected to V_{DD} for normal unlatched operation or to V_{SS} for latched operation. The $\overline{\text{LHDET}}$ pin is set HIGH on the board.

The TS12011/TS12012 demo board is configured to operate from a single supply voltage from 0.8V to 2.5V.

In both the non-inverting and the inverting configuration, the AC-coupling capacitor creates a high pass filter. The resulting cut-off frequency, f_c , is given as:

$$f_c = \frac{1}{2\pi RC}$$

In the non-inverting circuit, $R=R5=1\text{M}\Omega$ and $C=C5=0.1\mu\text{F}$. In the inverting case, $R=R10=1\text{M}\Omega$ and $C=C1=0.1\mu\text{F}$. In both cases, these component values generate a high-pass cut-off frequency of 1.6Hz.

Op-Amp Configuration

Non-Inverting configuration

In the non-inverting configuration, the circuit's transfer function is given by the following equation:

$$\frac{V_{OUT}}{V_{IN}} = 1 + \frac{R4}{R3}$$

With $R4=2\text{M}\Omega$ and $R3=2\text{M}\Omega$ the circuit signal gain is 2 with a circuit bandwidth of 2kHz. This results in an overall circuit bandwidth range of 1.6Hz to 2kHz.

Inverting configuration

In an inverting configuration, the circuit's transfer function is given by the following equation:

$$\frac{V_{OUT}}{V_{IN}} = - \frac{R6}{R10}$$

In this case, $R6=1\text{M}\Omega$ and $R10=1\text{M}\Omega$. This results in a signal gain of -1 with a circuit bandwidth of 2kHz and an overall circuit bandwidth range of 1.6Hz to 2kHz.

Quick Start Procedures

Required Equipment

- TS12011/TS12012 demo board
- DC Power Supply, Single or Dual Output
- Function Generator
- 4-channel Oscilloscope
- Two 1M Ω oscilloscope probes

Signal	TS12011		TS12012	
	Non-Inverting	Inverting	Non-Inverting	Inverting
V _{DD}	VDD			
GND	GND			
V _{IN}	IN1_N	IN1_I	IN2_N	IN2_I
V _{OUT}	OUT1_N	OUT1_I	OUT2_N	OUT2_I
REFOUT	REF1	REF1	REF2	REF2
Jumper Setting				
IN1+	1-2	2-3	1-2	2-3
IN1-	1-2	2-3	1-2	2-3
OUT1	1-2	2-3	1-2	2-3

Table 1. Demo Board Test Points

Non-Inverting Configuration

In order to evaluate the TS12011/TS12012 operational amplifier in the non-inverting configuration, jumpers IN1+, IN1-, and OUT1 are in position 1-2. Refer to Figure 2. The default configuration on the board is non-inverting. The following steps are to be performed:

- 1) Before connecting the DC power supply to the demo board power test points, turn on the power supply and set the DC voltage to 2.5V and then turn it off.
- 2) Set the function generator frequency to 500Hz and the signal swing to 200mV_{PP}.
- 3) In order to monitor the input and output signal, select two channels on the oscilloscope and set the vertical voltage scale and the vertical position on each channel to 200mV/DIV and 0V, respectively. Set the horizontal time scale to 500µs/DIV.
- 4) Connect the positive terminal of the DC power supply to VDD and the ground terminal to GND. For all other connections, please refer to Table 1.
- 5) If evaluating the TS12011, connect the signal output of the function generator to IN1_N and the ground terminal to GND. If evaluating the TS12012, connect the signal output of the function generator to IN2_N and the ground terminal to GND.
- 6) To monitor the input of the TS12011, connect the signal terminal of one of the oscilloscope probes to IN1_N and the ground terminal to GND. To monitor the output, use the second probe to connect the signal terminal to OUT1_N and the ground terminal to GND.

- 7) Turn on the power supply and check that the power supply current is approximately 60µA. The supply current is for the entire demo board that includes both the TS12011 and the TS12012 circuits.
- 8) Turn on the function generator.
- 9) Observe the input and output signal. The output signal is an amplified version of the input signal with an output swing of approximately 400mV_{PP}, corresponding to a signal gain of two.

Inverting Configuration

In order to evaluate the TS12011/TS12012 operational amplifier in the inverting configuration, jumpers IN1+, IN1-, and OUT1 are to be set to position 2-3. Refer to Figure 3. The following steps are to be performed:

- 1) Before connecting the DC power supply to the demo board, turn on the power supply and set the DC voltage to 2.5V and then turn it off.
- 2) Set the function generator frequency to 500Hz and the signal swing to 200mV_{PP}.
- 3) In order to monitor the input and output signal, select two channels on the oscilloscope and set the vertical voltage scale and the vertical position on each channel to 200mV/DIV and 0V, respectively. Set the horizontal time scale to 500µs/DIV.
- 4) Connect the positive terminal of the DC power supply to VDD and the ground terminal to GND. For all other connections, please refer to Table 1.
- 5) If evaluating the TS12011, connect the signal output of the function generator to IN1_I and the ground terminal to GND. If evaluating the TS12012, connect the signal output of the function generator to IN2_I and the ground terminal to GND.
- 6) To monitor the input of the TS12011, connect the signal terminal of one of the oscilloscope probes to IN1_I and the ground terminal to GND. To monitor the output, use the second probe to connect the signal terminal to OUT1_I and the ground terminal to GND. To monitor the input of the TS12012, connect the signal terminal of one of the oscilloscope probes to IN2_I and the ground terminal to GND. To monitor the output, use the second probe to connect the signal

TS12011/TS12012 Demo Board



terminal to OUT2_I and the ground terminal to GND.

- 7) Turn on the power supply and check that the power supply current is approximately $60\mu\text{A}$. The supply current is for the entire demo board that includes both the TS12011 and the TS12012 circuits.
- 8) Turn on the function generator.
- 9) Observe the input and output signal. The output signal is an inverted version of the input signal and the swing should be 200mV_{PP} .

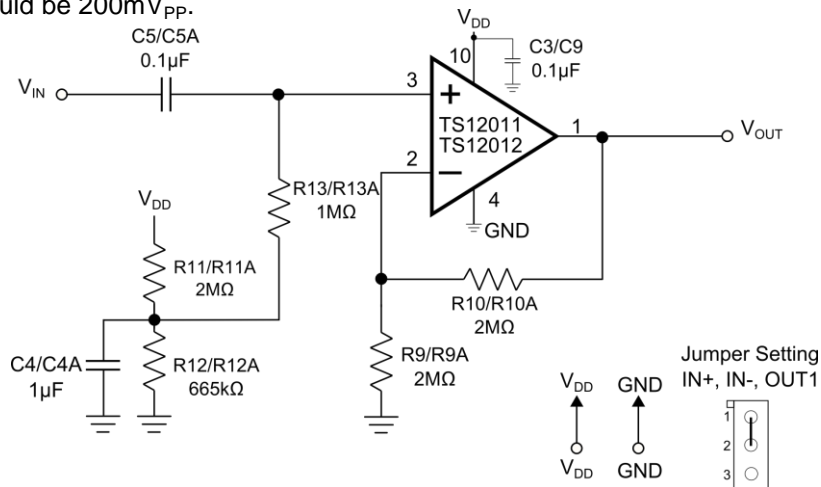

Figure 2. TS12011/TS12012 Non-Inverting Circuit

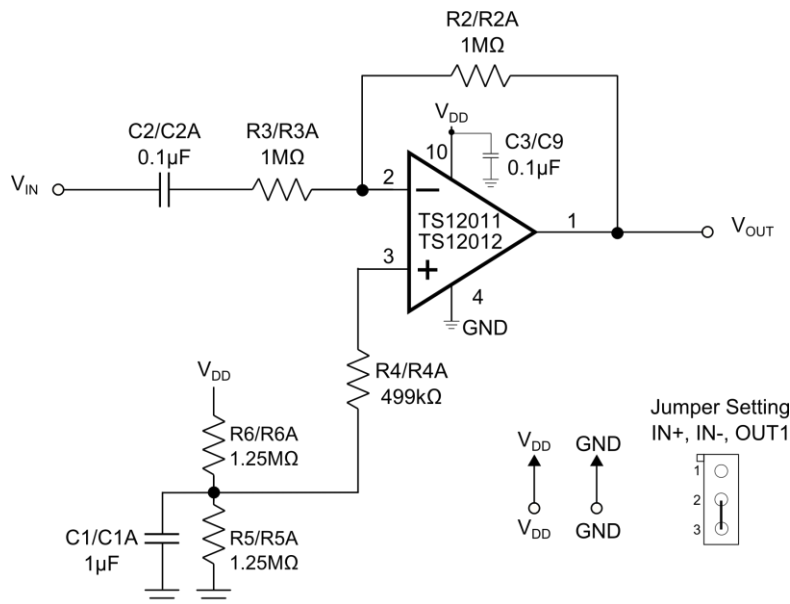

Figure 3. TS12011/TS12012 Inverting Circuit

Comparator Configuration

The default configuration for the comparator is with $V_{DD} = 2.5V$. If evaluation with a different supply voltage and/or additional hysteresis is desired, remove resistor R7, R8, R7A, R8A and capacitor C6 and C6A. Then, create a short between the capacitor pads of C6 and C6A. Please refer to page 7 of the TS12011/TS12012 product datasheet for the design equations necessary.

QUICK START PROCEDURES

Required Equipment

- TS12011/TS12012DB demo board
- A DC Power Supply, Single or Dual Output, an HP Model HP6624A or equivalent
- A Function Generator, an Agilent Model 33220A or equivalent
- 4-channel Oscilloscope, an Agilent Model DSO1014A or equivalent
- Two 1M Ω , 10x, oscilloscope probes

Signal	TS12011	TS12012
V_{DD}	VDD	
GND	GND	
V_{IN}	C_IN1	C_IN2
V_{OUT}	C_OUT1	C_OUT2
Jumper Setting		
LHDET/HLDB	1-2	

Table 2. Comparator Jumper Test Points

Comparator Threshold Detector

To evaluate the TS12011/TS12012 comparator threshold detector circuit, the following steps are to be performed:

- 1) Before connecting the DC power supply to the demo board power test points, turn on the power supply and set the DC voltage to 2.5V and then turn it off.
- 2) Set the function generator frequency to 500Hz and its output swing to 320mV_{PP}.
- 3) In order to monitor the input and output signal, select two channels on the oscilloscope and set the vertical voltage scale and the vertical position on the channel monitoring the input to 200mV/DIV and 0V, respectively, and on the channel monitoring the output to 1V/DIV and 0V,

respectively. Set the horizontal time scale to 500 μ s/DIV and set the input coupling on both channels to AC-coupling.

- 4) Connect the positive terminal of the DC power supply to VDD and its ground terminal to GND. For all other connections, please refer to Table 2.
- 5) If evaluating the TS12011, connect the signal output of the function generator to C_IN1 and the ground terminal to GND. If evaluating the TS12012, connect the signal output of the function generator to C_IN2 and the ground terminal to GND.
- 6) To monitor the input of the TS12011, connect the signal terminal of one of the oscilloscope probes to C_IN1 and the ground terminal to GND. To monitor the output, use the second probe to connect the signal terminal to C_OUT1 and the ground terminal to GND. To monitor the input of the TS12012, connect the signal terminal of one of the oscilloscope probes to C_IN2 and the ground terminal to GND. To monitor the output, use the second probe to connect the signal terminal to C_OUT2 and the ground terminal to GND.
- 7) Turn on the power supply and check that the power supply current is approximately 60 μ A. The supply current is for the entire demo board that includes both the TS12011 and the TS12012 circuits.
- 8) Turn on the function generator.
- 9) Observe the input and output signal. The output signal should alternate between 0V to 2.5V.

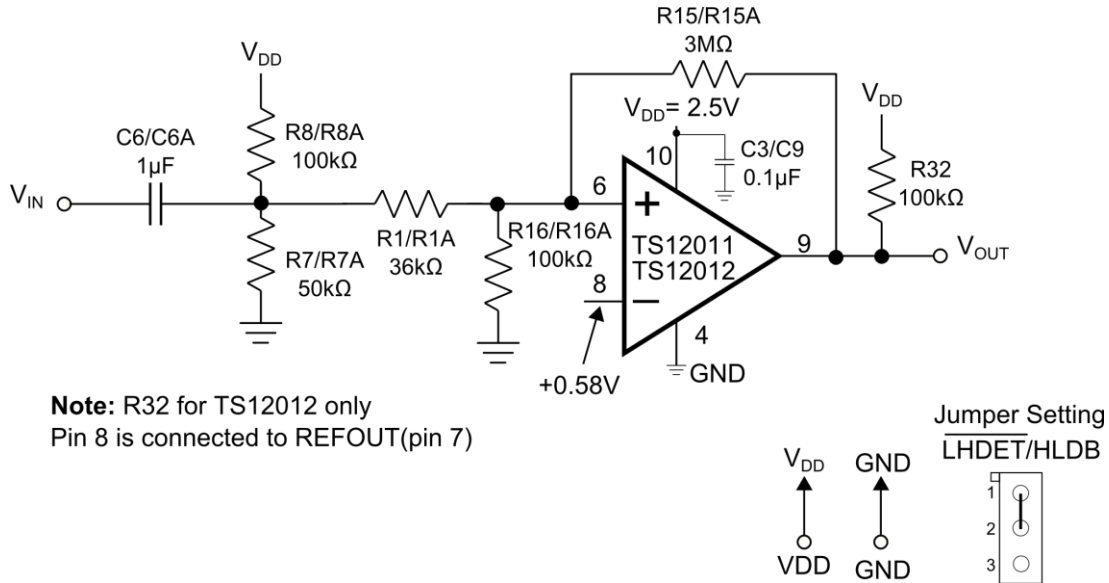

Figure 4. TS12011/TS12012 Comparator Circuit

COMPONENT LIST

DESIGNATION	QTY	DESCRIPTION
C2, C3, C5, C2A, C3A, C5A	6	0.1µF ±10% capacitor (0805)
C1, C4, C6, C1A, C4A, C6A	6	1µF ±10% capacitor (0805)
R2, R3, R13, R2A, R3A, R13A	6	1MΩ ± 1% (0805)
R9, R10, R11, R9A, R10A, R11A	6	2MΩ± 1% (0805)
R5, R6, R5A, R6A	4	1.25MΩ± 1% (0805)
R4, R4A	2	499kΩ± 1% (0805)
R12, R12A	2	665kΩ± 1% (0805)
R8, R8A, R16, R16A, R32	5	100kΩ± 1% (0805)
R7, R7A	2	50kΩ± 1% (0805)
R1, R1A	2	36kΩ± 1% (0805)
R15, R15A	2	3MΩ± 1% (0805)
OUT2_N, OUT2_I, IN2_I, C_OUT2, REF2, C_IN2, IN2_N, OUT1_N, OUT1_I, IN1_I, C_OUT1, REF1, C_IN1, IN1_N, VDD	15	Test points
HLDB1, HLDB2, IN1+, IN1-, OUT1, IN2+, IN2-, OUT2	8	Jumper
U1	1	TS12011ITD1022
U2	1	TS12012ITD1022

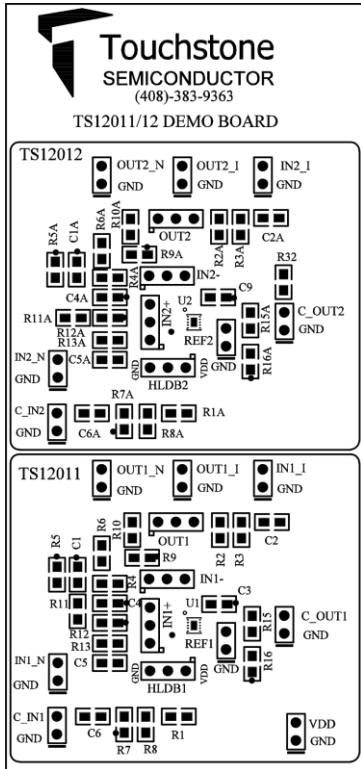

Figure 5. Top Layer Component View

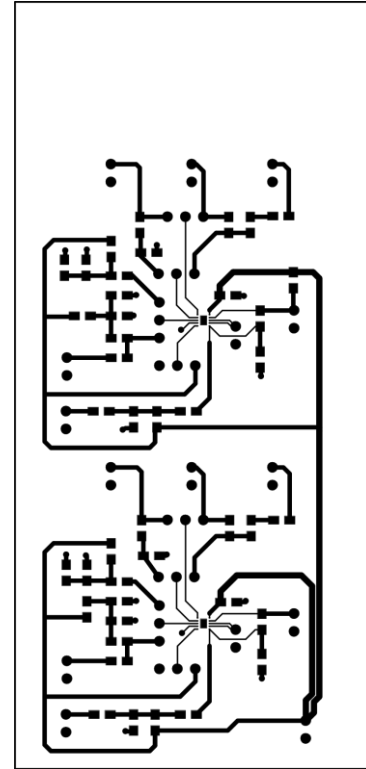

Figure 6. Top Layer Trace View

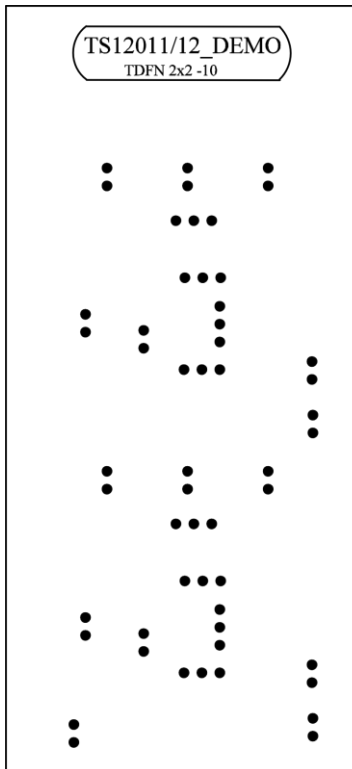

Figure 7. Bottom Layer (GND)

Компания «Океан Электроники» предлагает заключение долгосрочных отношений при поставках импортных электронных компонентов на взаимовыгодных условиях!

Наши преимущества:

- Поставка оригинальных импортных электронных компонентов напрямую с производств Америки, Европы и Азии, а так же с крупнейших складов мира;
- Широкая линейка поставок активных и пассивных импортных электронных компонентов (более 30 млн. наименований);
- Поставка сложных, дефицитных, либо снятых с производства позиций;
- Оперативные сроки поставки под заказ (от 5 рабочих дней);
- Экспресс доставка в любую точку России;
- Помощь Конструкторского Отдела и консультации квалифицированных инженеров;
- Техническая поддержка проекта, помощь в подборе аналогов, поставка прототипов;
- Поставка электронных компонентов под контролем ВП;
- Система менеджмента качества сертифицирована по Международному стандарту ISO 9001;
- При необходимости вся продукция военного и аэрокосмического назначения проходит испытания и сертификацию в лаборатории (по согласованию с заказчиком);
- Поставка специализированных компонентов военного и аэрокосмического уровня качества (Xilinx, Altera, Analog Devices, Intersil, Interpoint, Microsemi, Actel, Aeroflex, Peregrine, VPT, Syfer, Eurofarad, Texas Instruments, MS Kennedy, Miteq, Cobham, E2V, MA-COM, Hittite, Mini-Circuits, General Dynamics и др.);

Компания «Океан Электроники» является официальным дистрибьютором и эксклюзивным представителем в России одного из крупнейших производителей разъемов военного и аэрокосмического назначения «**JONHON**», а так же официальным дистрибьютором и эксклюзивным представителем в России производителя высокотехнологичных и надежных решений для передачи СВЧ сигналов «**FORSTAR**».



JONHON

«**JONHON**» (основан в 1970 г.)

Разъемы специального, военного и аэрокосмического назначения:

(Применяются в военной, авиационной, аэрокосмической, морской, железнодорожной, горно- и нефтедобывающей отраслях промышленности)

«**FORSTAR**» (основан в 1998 г.)

ВЧ соединители, коаксиальные кабели,
кабельные сборки и микроволновые компоненты:

(Применяются в телекоммуникациях гражданского и специального назначения, в средствах связи, РЛС, а так же военной, авиационной и аэрокосмической отраслях промышленности).



Телефон: 8 (812) 309-75-97 (многоканальный)

Факс: 8 (812) 320-03-32

Электронная почта: ocean@oceanchips.ru

Web: <http://oceanchips.ru/>

Адрес: 198099, г. Санкт-Петербург, ул. Калинина, д. 2, корп. 4, лит. А