

---

---

**8-bit tinyAVR<sup>®</sup> 1-Series Microcontroller**

---

---

---

**Introduction**

---

The ATtiny1614 is a member of the tinyAVR<sup>®</sup> 1-series of microcontrollers, using the AVR<sup>®</sup> 8-bit processor with hardware multiplier, running at up to 20 MHz and with 16 KB Flash, 2 KB of SRAM, and 256 bytes of EEPROM in a 14-pin package. The tinyAVR 1-series uses the latest technologies with a flexible and low-power architecture including Event System and SleepWalking, accurate analog features and advanced peripherals. Capacitive touch interfaces with proximity sensing and driven shield are supported with the integrated QTouch<sup>®</sup> peripheral touch controller.

---

**Features**

---

- CPU:
  - AVR<sup>®</sup> 8-bit CPU
  - Running at up to 20 MHz
  - Single-cycle I/O access
  - Two-level interrupt controller
  - Two-cycle hardware multiplier
- Memories:
  - 16 KB In-system self-programmable Flash memory
  - 256 bytes EEPROM
  - 2 KB SRAM
  - Write/erase endurance:
    - Flash 10,000 cycles
    - EEPROM 100,000 cycles
  - Data retention: 20 years at 85°C
- System:
  - Power-on Reset (POR)
  - Brown-out Detection (BOD)
  - Internal and external clock options:
    - 16/20 MHz low-power RC oscillator
    - 32.768 kHz Ultra Low-Power (ULP) internal RC oscillator with  $\pm 10\%$  accuracy,  $\pm 2\%$  calibration step size
    - 32.768 kHz external crystal oscillator
    - External clock input
  - Single pin programming and debugging interface (UPDI)
  - Three Sleep modes:
    - Idle with all peripherals running for immediate wake-up

- Standby
  - Configurable operation of selected peripherals
  - SleepWalking peripherals
- Power-down with limited wake-up functionality
- Peripherals:
  - One 16-bit timer/counter type A with dedicated period register, three compare channels (TCA)
  - Two 16-bit timer/counter type B with input capture (TCB)
  - One 12-bit timer/counter type D optimized for control applications (TCD)
  - 16-bit Real-Time Counter (RTC) running from an external crystal, external clock, or internal RC oscillator
  - One USART with fractional baud rate generator, auto-baud, and start-of-frame detection
  - Master/slave Serial Peripheral Interface (SPI)
  - Master/slave I<sup>2</sup>C with dual address match
    - Standard mode (Sm, 100 kHz)
    - Fast mode (Fm, 400 kHz)
    - Fast mode plus (Fm+, 1 MHz)
  - Configurable Custom Logic (CCL) with two programmable Look-up Tables (LUT)
  - Three Analog Comparators (AC) with low propagation delay
  - Two 10-bit 115 ksp/s Analog-to-Digital Converters (ADC)
  - Three 8-bit Digital-to-Analog Converters (DAC) with one external channel
  - Five selectable internal voltage references: 0.55V, 1.1V, 1.5V, 2.5V, and 4.3V
  - Automated CRC memory scan
  - Window Watchdog Timer (WDT) with separate on-chip oscillator
  - Peripheral Touch Controller (PTC)
    - Capacitive touch buttons, sliders, and wheels
    - Wake-up on touch
    - Driven shield for improved moisture and noise handling performance
    - Up to 6 self-capacitance and up to 9 mutual capacitance channels
  - External interrupt on all general purpose pins
- I/O and Packages:
  - 12 programmable I/O lines
  - 14-pin SOIC150
- Temperature Ranges:
  - -40°C to 105°C
  - -40°C to 125°C
- Speed Grades:
  - 0-5 MHz @ 1.8V – 5.5V
  - 0-10 MHz @ 2.7V – 5.5V
  - 0-20 MHz @ 4.5V – 5.5V

## Table of Contents

---

Introduction.....	1
Features.....	1
1. tinyAVR <sup>®</sup> 1-series Overview.....	10
1.1. Configuration Summary.....	10
2. Ordering Information.....	12
3. Block Diagram.....	13
4. Pinout.....	14
4.1. 14-Pin SOIC.....	14
5. I/O Multiplexing and Considerations.....	15
5.1. Multiplexed Signals.....	15
6. Memories.....	16
6.1. Overview.....	16
6.2. Memory Map.....	17
6.3. In-System Reprogrammable Flash Program Memory.....	17
6.4. SRAM Data Memory.....	18
6.5. EEPROM Data Memory.....	18
6.6. User Row.....	18
6.7. Signature Bytes.....	19
6.8. I/O Memory.....	19
6.9. Memory Section Access from CPU and UPDI on Locked Device.....	20
6.10. Configuration and User Fuses (FUSE).....	21
7. Peripherals and Architecture.....	42
7.1. Peripheral Module Address Map.....	42
7.2. Interrupt Vector Mapping.....	43
7.3. System Configuration (SYSCFG).....	45
8. AVR CPU.....	48
8.1. Features.....	48
8.2. Overview.....	48
8.3. Architecture.....	48
8.4. Arithmetic Logic Unit (ALU).....	50
8.5. Functional Description.....	51
8.6. Register Summary - CPU.....	56
8.7. Register Description.....	56
9. NVMCTRL - Nonvolatile Memory Controller.....	61
9.1. Features.....	61

9.2. Overview.....	61
9.3. Functional Description.....	62
9.4. Register Summary - NVMCTRL.....	69
9.5. Register Description.....	69
<b>10. CLKCTRL - Clock Controller.....</b>	<b>77</b>
10.1. Features.....	77
10.2. Overview.....	77
10.3. Functional Description.....	79
10.4. Register Summary - CLKCTRL.....	84
10.5. Register Description.....	84
<b>11. SLPCTRL - Sleep Controller.....</b>	<b>95</b>
11.1. Features.....	95
11.2. Overview.....	95
11.3. Functional Description.....	97
11.4. Register Summary - SLPCTRL.....	99
11.5. Register Description.....	99
<b>12. RSTCTRL - Reset Controller.....</b>	<b>101</b>
12.1. Features.....	101
12.2. Overview.....	101
12.3. Functional Description.....	102
12.4. Register Summary - RSTCTRL.....	105
12.5. Register Description.....	105
<b>13. CPUINT - CPU Interrupt Controller.....</b>	<b>108</b>
13.1. Features.....	108
13.2. Overview.....	108
13.3. Functional Description.....	110
13.4. Register Summary - CPUINT.....	117
13.5. Register Description.....	117
<b>14. EVSYS - Event System.....</b>	<b>122</b>
14.1. Features.....	122
14.2. Overview.....	122
14.3. Functional Description.....	125
14.4. Register Summary - EVSYS.....	127
14.5. Register Description.....	127
<b>15. PORTMUX - Port Multiplexer.....</b>	<b>136</b>
15.1. Overview.....	136
15.2. Register Summary - PORTMUX.....	137
15.3. Register Description.....	137
<b>16. PORT - I/O Pin Configuration.....</b>	<b>141</b>
16.1. Features.....	141
16.2. Overview.....	141

16.3. Functional Description.....	143
16.4. Register Summary - PORT.....	147
16.5. Register Description - Ports.....	147
16.6. Register Summary - VPORT.....	159
16.7. Register Description - Virtual Ports.....	159
<b>17. BOD - Brown-out Detector.....</b>	<b>164</b>
17.1. Features.....	164
17.2. Overview.....	164
17.3. Functional Description.....	166
17.4. Register Summary - BOD.....	168
17.5. Register Description.....	168
<b>18. VREF - Voltage Reference.....</b>	<b>175</b>
18.1. Features.....	175
18.2. Overview.....	175
18.3. Functional Description.....	175
18.4. Register Summary - VREF.....	177
18.5. Register Description.....	177
<b>19. WDT - Watchdog Timer.....</b>	<b>180</b>
19.1. Features.....	180
19.2. Overview.....	180
19.3. Functional Description.....	182
19.4. Register Summary - WDT.....	186
19.5. Register Description.....	186
<b>20. TCA - 16-bit Timer/Counter Type A.....</b>	<b>190</b>
20.1. Features.....	190
20.2. Overview.....	190
20.3. Functional Description.....	194
20.4. Register Summary - TCA in Normal Mode (CTRLD.SPLITM=0).....	204
20.5. Register Description - Normal Mode.....	205
20.6. Register Summary - TCA in Split Mode (CTRLD.SPLITM=1).....	225
20.7. Register Description - Split Mode.....	225
<b>21. TCB - 16-bit Timer/Counter Type B.....</b>	<b>241</b>
21.1. Features.....	241
21.2. Overview.....	241
21.3. Functional Description.....	244
21.4. Register Summary - TCB.....	252
21.5. Register Description.....	252
<b>22. TCD - 12-Bit Timer/Counter Type D.....</b>	<b>264</b>
22.1. Features.....	264
22.2. Overview.....	264
22.3. Functional Description.....	268
22.4. Register Summary - TCD.....	290

22.5. Register Description.....	291
<b>23. RTC - Real-Time Counter.....</b>	<b>312</b>
23.1. Features.....	312
23.2. Overview.....	312
23.3. RTC Functional Description.....	315
23.4. PIT Functional Description.....	315
23.5. Events.....	317
23.6. Interrupts.....	318
23.7. Sleep Mode Operation.....	318
23.8. Synchronization.....	319
23.9. Configuration Change Protection.....	319
23.10. Register Summary - RTC.....	320
23.11. Register Description.....	320
<b>24. USART - Universal Synchronous and Asynchronous Receiver and Transmitter..</b>	<b>336</b>
24.1. Features.....	336
24.2. Overview.....	336
24.3. Functional Description.....	340
24.4. Register Summary - USART.....	356
24.5. Register Description.....	356
<b>25. SPI - Serial Peripheral Interface.....</b>	<b>375</b>
25.1. Features.....	375
25.2. Overview.....	375
25.3. Functional Description.....	378
25.4. Register Summary - SPI.....	388
25.5. Register Description.....	388
<b>26. TWI - Two-Wire Interface.....</b>	<b>397</b>
26.1. Features.....	397
26.2. Overview.....	397
26.3. Functional Description.....	399
26.4. Register Summary - TWI.....	413
26.5. Register Description.....	413
<b>27. CRCSCAN - Cyclic Redundancy Check Memory Scan.....</b>	<b>433</b>
27.1. Features.....	433
27.2. Overview.....	433
27.3. Functional Description.....	435
27.4. Register Summary - CRCSCAN.....	438
27.5. Register Description.....	438
<b>28. CCL - Configurable Custom Logic.....</b>	<b>442</b>
28.1. Features.....	442
28.2. Overview.....	442
28.3. Functional Description.....	444
28.4. Register Summary - CCL.....	453

28.5. Register Description.....	453
<b>29. AC - Analog Comparator.....</b>	<b>463</b>
29.1. Features.....	463
29.2. Overview.....	463
29.3. Functional Description.....	465
29.4. Register Summary - AC.....	468
29.5. Register Description.....	468
<b>30. ADC - Analog-to-Digital Converter.....</b>	<b>474</b>
30.1. Features.....	474
30.2. Overview.....	474
30.3. Functional Description.....	478
30.4. Register Summary - ADCn.....	486
30.5. Register Description.....	486
<b>31. DAC - Digital-to-Analog Converter.....</b>	<b>504</b>
31.1. Features.....	504
31.2. Overview.....	504
31.3. Functional Description.....	506
31.4. Register Summary - DAC.....	508
31.5. Register Description.....	508
<b>32. Peripheral Touch Controller (PTC).....</b>	<b>511</b>
32.1. Overview.....	511
32.2. Features.....	511
32.3. Block Diagram.....	512
32.4. Signal Description.....	512
32.5. System Dependencies.....	513
32.6. Functional Description.....	514
<b>33. UPDI - Unified Program and Debug Interface.....</b>	<b>516</b>
33.1. Features.....	516
33.2. Overview.....	516
33.3. Functional Description.....	519
33.4. Register Summary - UPDI.....	539
33.5. Register Description.....	539
<b>34. Instruction Set Summary.....</b>	<b>550</b>
<b>35. Conventions.....</b>	<b>555</b>
35.1. Numerical Notation.....	555
35.2. Memory Size and Type.....	555
35.3. Frequency and Time.....	555
35.4. Registers and Bits.....	556
<b>36. Acronyms and Abbreviations.....</b>	<b>557</b>

<b>37. Electrical Characteristics</b> .....	<b>560</b>
37.1. Disclaimer.....	560
37.2. Absolute Maximum Ratings .....	560
37.3. General Operating Ratings .....	561
37.4. Power Consumption for ATtiny1614.....	562
37.5. Wake-Up Time.....	563
37.6. Power Consumption of Peripherals.....	564
37.7. BOD and POR Characteristics.....	565
37.8. External Reset Characteristics.....	566
37.9. Oscillators and Clocks.....	566
37.10. I/O Pin Characteristics.....	568
37.11. USART.....	569
37.12. SPI.....	570
37.13. TWI.....	571
37.14. VREF.....	573
37.15. ADC.....	574
37.16. DAC.....	576
37.17. AC.....	577
37.18. PTC.....	578
37.19. UPDI Timing.....	579
37.20. Programming Time.....	580
<b>38. Typical Characteristics</b> .....	<b>581</b>
38.1. Power Consumption.....	581
38.2. GPIO.....	588
38.3. VREF Characteristics.....	596
38.4. BOD Characteristics.....	598
38.5. ADC Characteristics.....	601
38.6. AC Characteristics.....	606
38.7. OSC20M Characteristics.....	610
38.8. OSCULP32K Characteristics.....	612
<b>39. Package Drawings</b> .....	<b>613</b>
39.1. 14-Pin SOIC150.....	613
39.2. Thermal Considerations.....	614
<b>40. Errata</b> .....	<b>615</b>
40.1. ATtiny1614 Errata .....	615
<b>41. Data Sheet Revision History</b> .....	<b>619</b>
41.1. Rev. A - 06/2018.....	619
<b>The Microchip Web Site</b> .....	<b>620</b>
<b>Customer Change Notification Service</b> .....	<b>620</b>
<b>Customer Support</b> .....	<b>620</b>



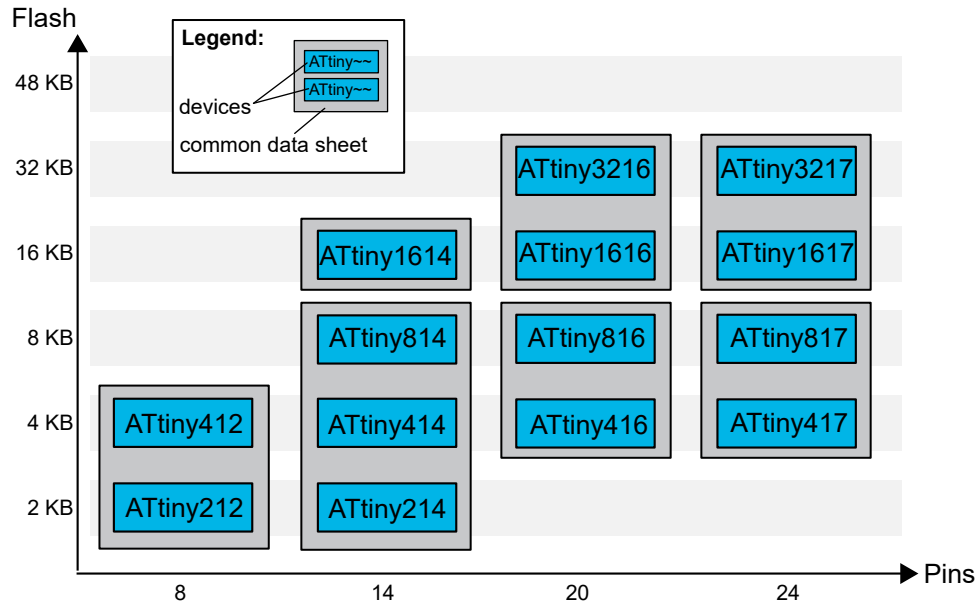
Product Identification System.....	621
Microchip Devices Code Protection Feature.....	621
Legal Notice.....	621
Trademarks.....	622
Quality Management System Certified by DNV.....	622
Worldwide Sales and Service.....	623

## 1. tinyAVR® 1-series Overview

The figure below shows the tinyAVR® 1-series devices, laying out pin count variants and memory sizes:

- Vertical migration upwards is possible without code modification, as these devices are pin compatible and provide the same or more features. Downward migration may require code modification due to fewer available instances of some peripherals.
- Horizontal migration to the left reduces the pin count and therefore, the available features.

**Figure 1-1. tinyAVR® 1-series Overview**



Devices with different Flash memory size typically also have different SRAM and EEPROM.

### Related Links

[6. Memories](#)

## 1.1 Configuration Summary

### 1.1.1 Peripheral Summary

**Table 1-1. Peripheral Summary**

	ATtiny1614
Pins	14
SRAM	2 KB
Flash	16 KB
EEPROM	256B
Max. frequency (MHz)	20
16-bit Timer/Counter type A (TCA)	1
16-bit Timer/Counter type B (TCB)	2
12-bit Timer/Counter type D (TCD)	1
Real Time Counter (RTC)	1

	ATtiny1614
USART	1
SPI	1
TWI (I <sup>2</sup> C)	1
ADC	2
ADC channels	10+4
DAC	3
AC	3
Peripheral Touch Controller (PTC) <sup>(1)</sup>	1
PTC number of self-capacitance channels <sup>(1)</sup>	6XY
PTC number of mutual-capacitance channels <sup>(1)</sup>	9
Custom Logic/Configurable Lookup Tables	1
Window Watchdog	1
Event System channels	6
General purpose I/O	12
External interrupts	12
CRCSCAN	1

**Note:**

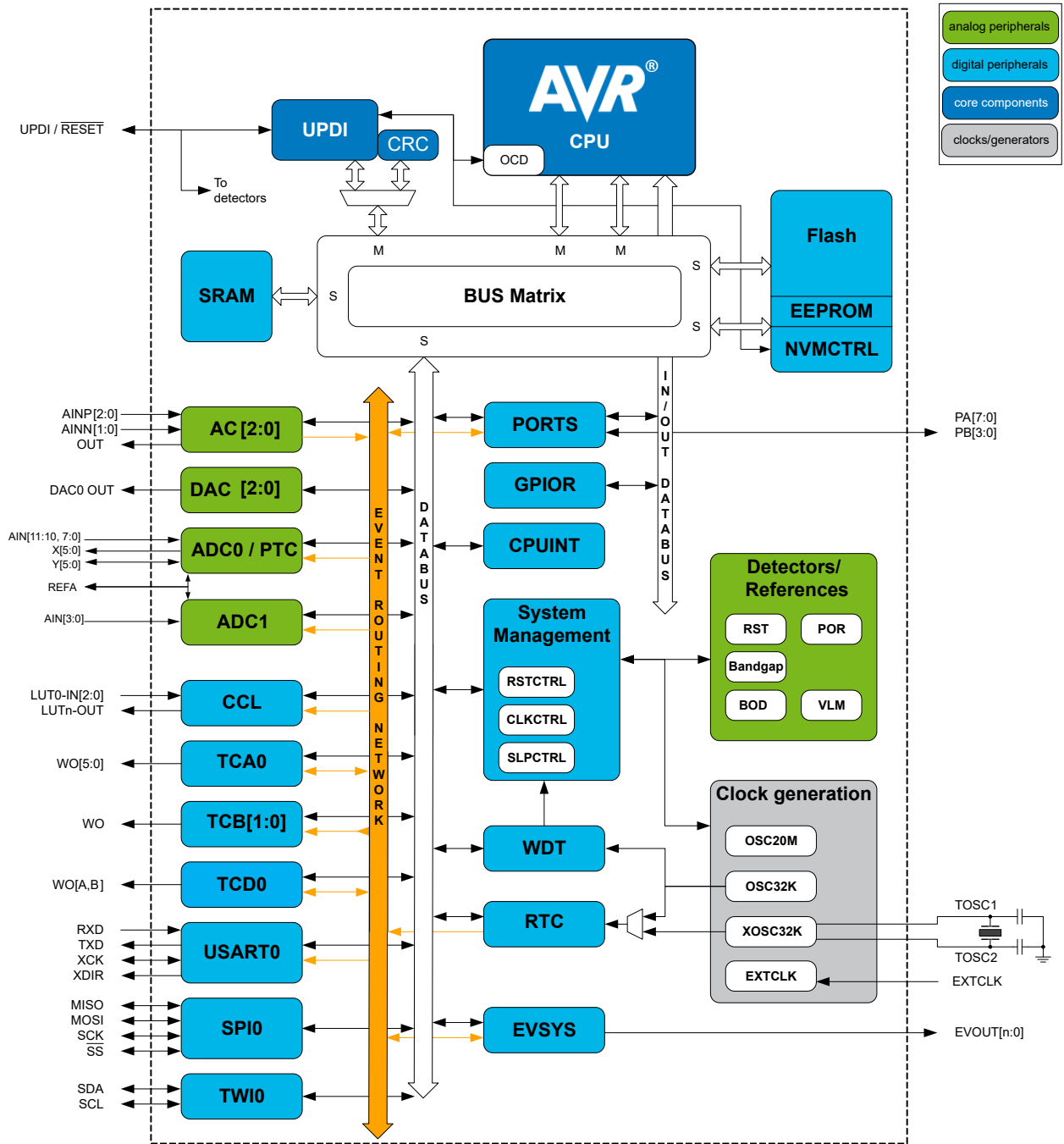
1. The PTC takes control over the ADC0 while the PTC is used.

**2. Ordering Information**

Find available ordering options online at [microchipdirect.com](http://microchipdirect.com), or contact your local sales representative.

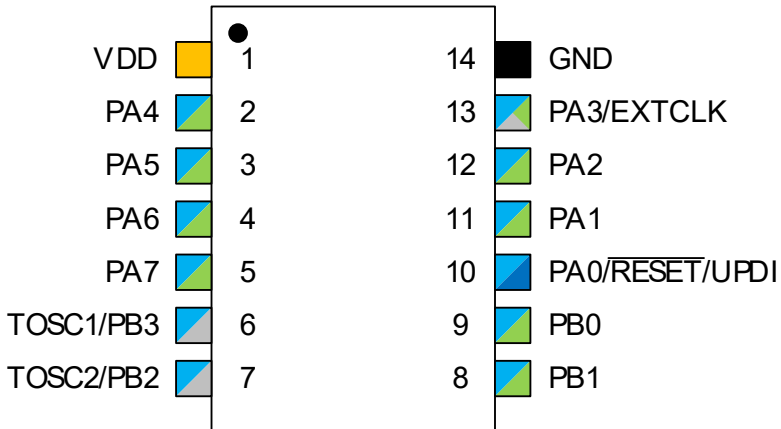
### 3. Block Diagram








Figure 3-1. ATtiny1614 Block Diagram



### 4. Pinout

#### 4.1 14-Pin SOIC



-  Input supply
-  Ground
-  GPIO VDD power domain
-  Programming, Debug, Reset
-  Clock, crystal
-  Digital function only
-  Analog function

### 5. I/O Multiplexing and Considerations

#### 5.1 Multiplexed Signals

Table 5-1. PORT Function Multiplexing

SOC 14-pin	Pin Name <sup>(1,2)</sup>	Other/Special	ADC0	ADC1	PTC <sup>(3)</sup>	AC0	AC1	AC2	DAC0	USART0	SPI0	TWI0	TCA0	TCBn	TCD0	CCL
10	PA0	RESET UPDI	AIN0													LUT0-IN0
11	PA1		AIN1							TXD	MOSI	SDA				LUT0-IN1
12	PA2	EVOUT0	AIN2							RxD	MISO	SCL				LUT0-IN2
13	PA3	EXTCLK	AIN3							XCK	SCK		WO3	TCB1 WO		
14	GND															
1	VDD															
2	PA4		AIN4	AIN0	X0/Y0					XDIR	SS		WO4		WOA	LUT0-OUT
3	PA5	VREFA	AIN5	AIN1	X1/Y1	OUT	AINN0						WO5	TCB0 WO	WOB	
4	PA6		AIN6	AIN2	X2/Y2	AINN0	AINP1	AINP0	OUT							
5	PA7		AIN7	AIN3	X3/Y3	AINP0	AINP0	AINN0								LUT1-OUT
6	PB3	TOSC1					OUT			RxD			WO0			
7	PB2	TOSC2, EVOUT1						OUT		TxD			WO2			
8	PB1		AIN10		X4/Y4	AINP2				XCK		SDA	WO1			
9	PB0		AIN11		X5/Y5		AINP2	AINP1		XDIR		SCL	WO0			

**Note:**

1. Pin names are of type P<sub>xn</sub>, with *x* being the PORT instance (A, B) and *n* the pin number. Notation for signals is PORT<sub>x</sub>\_PIN<sub>n</sub>. All pins can be used as event input.
2. All pins can be used for external interrupt, where pins P<sub>x2</sub> and P<sub>x6</sub> of each port have full asynchronous detection.
3. Every PTC line can be configured as X- or Y-line.



**Tip:** Signals on alternative pin locations are in *typewriter font*.

## 6. Memories

### 6.1 Overview

The main memories are SRAM data memory, EEPROM data memory, and Flash program memory. In addition, the peripheral registers are located in the I/O memory space.

**Table 6-1. Physical Properties of EEPROM**

Property	ATtiny1614
Size	256 bytes
Page size	32 bytes
Number of pages	8
Start address	0x1400

**Table 6-2. Physical Properties of SRAM**

Property	ATtiny1614
Size	2 KB
Start address	0x3800

**Table 6-3. Physical Properties of Flash Memory**

Property	ATtiny1614
Size	16 KB
Page size	64 bytes
Number of pages	256
Start address	0x8000

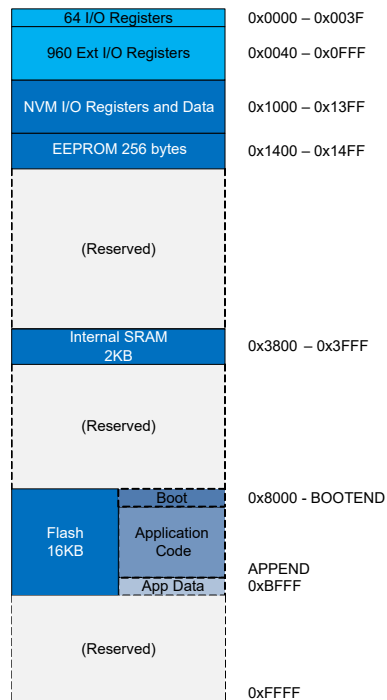
#### Related Links

- [6.2 Memory Map](#)
- [6.5 EEPROM Data Memory](#)
- [6.4 SRAM Data Memory](#)
- [6.3 In-System Reprogrammable Flash Program Memory](#)
- [9. NVMCTRL - Nonvolatile Memory Controller](#)



## 6.2 Memory Map

Figure 6-1. Memory Map ATtiny1614



## 6.3 In-System Reprogrammable Flash Program Memory

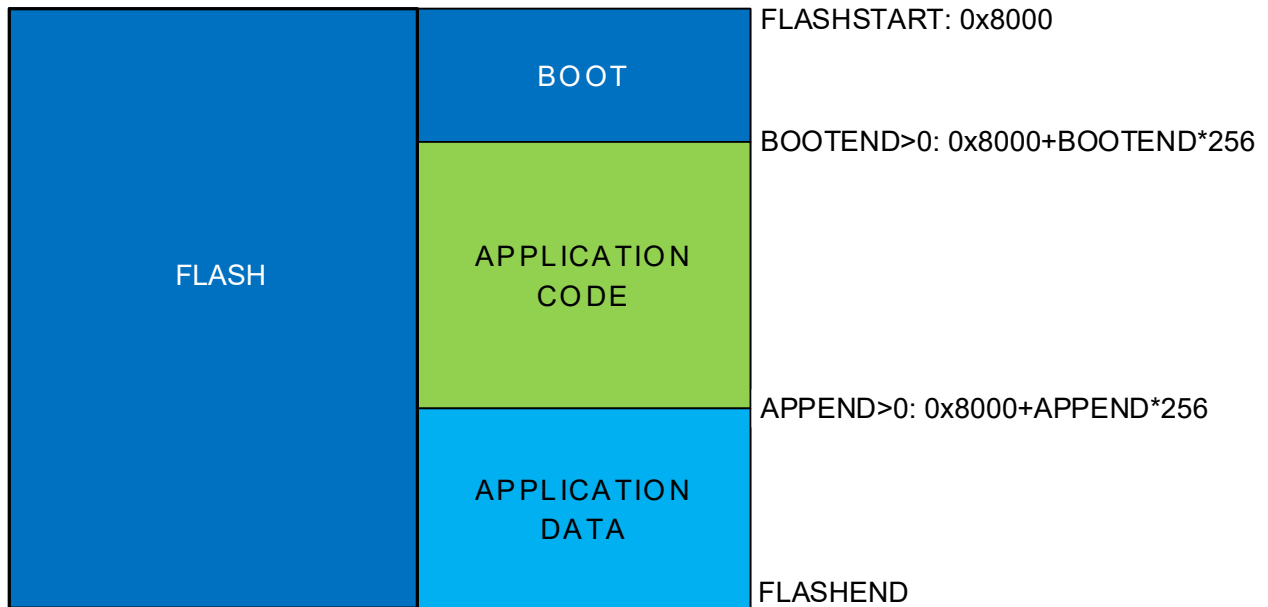
The ATtiny1614 contains 16 KB on-chip in-system reprogrammable Flash memory for program storage. Since all AVR instructions are 16 or 32 bits wide, the Flash is organized as 4K x 16. For write protection, the Flash program memory space can be divided into three sections (see the illustration below): Bootloader section, application code section, and application data section, with restricted access rights among them.

The Program Counter (PC) is 13 bits wide to address the whole program memory. The procedure for writing Flash memory is described in detail in the documentation of the Nonvolatile Memory Controller (NVMCTRL) peripheral.

The entire Flash memory is mapped in the memory space and is accessible with normal LD/ST instructions as well as the LPM instruction. For LD/ST instructions, the Flash is mapped from address 0x8000. For the LPM instruction, the Flash start address is 0x0000.

The ATtiny1614 also has a CRC peripheral that is a master on the bus.

**Figure 6-2. Flash and the Three Sections**



### Related Links

- [1.1 Configuration Summary](#)
- [9. NVMCTRL - Nonvolatile Memory Controller](#)

## 6.4 SRAM Data Memory

The 2 KB SRAM is used for data storage and stack.

### Related Links

- [8. AVR CPU](#)
- [8.5.4 Stack and Stack Pointer](#)

## 6.5 EEPROM Data Memory

The ATtiny1614 has 256 bytes of EEPROM data memory, see Memory Map section. The EEPROM memory supports single byte read and write. The EEPROM is controlled by the Nonvolatile Memory Controller (NVMCTRL).

### Related Links

- [6.2 Memory Map](#)
- [9. NVMCTRL - Nonvolatile Memory Controller](#)
- [17. BOD - Brown-out Detector](#)

## 6.6 User Row

In addition to the EEPROM, the ATtiny1614 has one extra page of EEPROM memory that can be used for firmware settings, the User Row (USERROW). This memory supports single byte read and write as the normal EEPROM. The CPU can write and read this memory as normal EEPROM and the UPDI can write and read it as a normal EEPROM memory if the part is unlocked. The User Row can be written by the UPDI when the part is locked. USERROW is not affected by a chip erase.

### Related Links

- [6.2 Memory Map](#)
- [9. NVMCTRL - Nonvolatile Memory Controller](#)
- [33. UPDI - Unified Program and Debug Interface](#)

## 6.7 Signature Bytes

All ATtiny microcontrollers have a 3-byte signature code that identifies the device. The three bytes reside in a separate address space. For the device, the signature bytes are given in the following table.

**Note:** When the device is locked, only the System Information Block (SIB) can be obtained.

**Table 6-4. Device ID**

Device Name	Signature Bytes Address		
	0x00	0x01	0x02
ATtiny1614	0x1E	0x94	0x22

### Related Links

- [33.3.6 System Information Block](#)

## 6.8 I/O Memory

All ATtiny1614 I/Os and peripherals are located in the I/O memory space. The I/O address range from 0x00 to 0x3F can be accessed in a single cycle using `IN` and `OUT` instructions. The extended I/O memory space from 0x0040 - 0x0FFF can be accessed by the `LD/LDS/LDD` and `ST/STS/STD` instructions, transferring data between the 32 general purpose working registers and the I/O memory space.

I/O registers within the address range 0x00 - 0x1F are directly bit accessible using the `SBI` and `CBI` instructions. In these registers, the value of single bits can be checked by using the `SBIS` and `SBIC` instructions. Refer to the Instruction Set section for more details.

For compatibility with future devices, reserved bits should be written to zero if accessed. Reserved I/O memory addresses should never be written.

Some of the interrupt flags are cleared by writing a '1' to them. On ATtiny1614 devices, the `CBI` and `SBI` instructions will only operate on the specified bit and can be used on registers containing such interrupt flags. The `CBI` and `SBI` instructions work with registers 0x00 - 0x1F only.

### General Purpose I/O Registers

The ATtiny1614 devices provide four general purpose I/O registers. These registers can be used for storing any information, and they are particularly useful for storing global variables and interrupt flags. General purpose I/O registers, which reside in the address range 0x1C - 0x1F, are directly bit accessible using the `SBI`, `CBI`, `SBIS`, and `SBIC` instructions.

### Related Links

- [6.2 Memory Map](#)
- [34. Instruction Set Summary](#)

### 6.9 Memory Section Access from CPU and UPDI on Locked Device

The device can be locked so that the memories cannot be read using the UPDI. The locking protects both the Flash (all BOOT, APPCODE, and APPDATA sections), SRAM, and the EEPROM including the FUSE data. This prevents successful reading of application data or code using the debugger interface. Regular memory access from within the application still is enabled.

The device is locked by writing any non-valid value to the LOCKBIT bit field in FUSE.LOCKBIT.

**Table 6-5. Memory Access in Unlocked Mode (FUSE.LOCKBIT Valid)<sup>(1)</sup>**

Memory Section	CPU Access		UPDI Access	
	Read	Write	Read	Write
SRAM	Yes	Yes	Yes	Yes
Registers	Yes	Yes	Yes	Yes
Flash	Yes	Yes	Yes	Yes
EEPROM	Yes	Yes	Yes	Yes
USERROW	Yes	Yes	Yes	Yes
SIGROW	Yes	No	Yes	No
Other Fuses	Yes	No	Yes	Yes

**Table 6-6. Memory Access in Locked Mode (FUSE.LOCKBIT Invalid)<sup>(1)</sup>**

Memory Section	CPU Access		UPDI Access	
	Read	Write	Read	Write
SRAM	Yes	Yes	No	No
Registers	Yes	Yes	No	No
Flash	Yes	Yes	No	No
EEPROM	Yes	No	No	No
USERROW	Yes	Yes	No	Yes <sup>(2)</sup>
SIGROW	Yes	No	No	No
Other Fuses	Yes	No	No	No

**Note:**

1. Read operations marked No in the tables may appear to be successful, but the data is corrupt. Hence, any attempt of code validation through the UPDI will fail on these memory sections.
2. In Locked mode, the USERROW can be written blindly using the fuse Write command, but the current USERROW values cannot be read out.



**Important:** The only way to unlock a device is a CHIPERASE, which will erase all device memories to factory default so that no application data is retained.

### Related Links

[6.10.3 Fuse Summary - FUSE](#)

[6.10.4.9 LOCKBIT](#)

[33. UPDI - Unified Program and Debug Interface](#)

[33.3.7 Enabling of KEY Protected Interfaces](#)

## 6.10 Configuration and User Fuses (FUSE)

Fuses are part of the nonvolatile memory and hold factory calibration data and device configuration. The fuses are available from device power-up. The fuses can be read by the CPU or the UPDI, but can only be programmed or cleared by the UPDI. The configuration and calibration values stored in the fuses are written to their respective target registers at the end of the start-up sequence.

The content of the Signature Row fuses (SIGROW) is pre-programmed and cannot be altered. SIGROW holds information such as device ID, serial number, and calibration values.

The fuses for peripheral configuration (FUSE) are pre-programmed but can be altered by the user. Altered values in the configuration fuse will be effective only after a Reset.

**Note:** When writing the fuses write all reserved bits to '1'.

This device provides a User Row fuse area (USERROW) that can hold application data. The USERROW can be programmed on a locked device by the UPDI. This can be used for final configuration without having programming or debugging capabilities enabled.

### Related Links

[6.10.1 SIGROW - Signature Row Summary](#)

[6.10.3 Fuse Summary - FUSE](#)

[7.1 Peripheral Module Address Map](#)

### 6.10.1 SIGROW - Signature Row Summary

Offset	Name	Bit Pos.								
0x00	DEVICEID0	7:0								DEVICEID[7:0]
0x01	DEVICEID1	7:0								DEVICEID[7:0]
0x02	DEVICEID2	7:0								DEVICEID[7:0]
0x03	SERNUM0	7:0								SERNUM[7:0]
0x04	SERNUM1	7:0								SERNUM[7:0]
0x05	SERNUM2	7:0								SERNUM[7:0]
0x06	SERNUM3	7:0								SERNUM[7:0]
0x07	SERNUM4	7:0								SERNUM[7:0]
0x08	SERNUM5	7:0								SERNUM[7:0]
0x09	SERNUM6	7:0								SERNUM[7:0]
0x0A	SERNUM7	7:0								SERNUM[7:0]
0x0B	SERNUM8	7:0								SERNUM[7:0]
0x0C	SERNUM9	7:0								SERNUM[7:0]
0x0D	Reserved									
...										
0x1F										
0x20	TEMPSENSE0	7:0								TEMPSENSE[7:0]
0x21	TEMPSENSE1	7:0								TEMPSENSE[7:0]
0x22	OSC16ERR3V	7:0								OSC16ERR3V[7:0]
0x23	OSC16ERR5V	7:0								OSC16ERR5V[7:0]
0x24	OSC20ERR3V	7:0								OSC20ERR3V[7:0]
0x25	OSC20ERR5V	7:0								OSC20ERR5V[7:0]

### 6.10.2 Signature Row Description

### 6.10.2.1 Device ID n

**Name:** DEVICEIDn  
**Offset:** 0x00 + n\*0x01 [n=0..2]  
**Reset:** [Device ID]  
**Property:** -

Each device has a device ID identifying the device and its properties; such as memory sizes, pin count, and die revision. This can be used to identify a device and hence, the available features by software. The Device ID consists of three bytes: SIGROW.DEVICEID[2:0].

Bit	7	6	5	4	3	2	1	0
	DEVICEID[7:0]							
Access	R	R	R	R	R	R	R	R
Reset	x	x	x	x	x	x	x	x

**Bits 7:0 – DEVICEID[7:0]** Byte n of the Device ID

### 6.10.2.2 Serial Number Byte n

**Name:** SERNUMn  
**Offset:** 0x03 + n\*0x01 [n=0..9]  
**Reset:** [device serial number]  
**Property:** -

Each device has an individual serial number, representing a unique ID. This can be used to identify a specific device in the field. The serial number consists of ten bytes: SIGROW.SERNUM[9:0].

Bit	7	6	5	4	3	2	1	0
	SERNUM[7:0]							
Access	R	R	R	R	R	R	R	R
Reset	x	x	x	x	x	x	x	x

**Bits 7:0 – SERNUM[7:0]** Serial Number Byte n



### 6.10.2.3 Temperature Sensor Calibration n

**Name:** TEMPSENSEn  
**Offset:**  $0x20 + n*0x01$  [ $n=0..1$ ]  
**Reset:** [Temperature sensor calibration value]  
**Property:** -

These registers contain correction factors for temperature measurements by the ADC. SIGROW.TEMPSENSE0 is a correction factor for the gain/slope (unsigned), SIGROW.TEMPSENSE1 is a correction factor for the offset (signed).

Bit	7	6	5	4	3	2	1	0
	TEMPSENSE[7:0]							
Access	R	R	R	R	R	R	R	R
Reset	x	x	x	x	x	x	x	x

**Bits 7:0 – TEMPSENSE[7:0]** Temperature Sensor Calibration Byte n  
 Refer to the ADC chapter for a description on how to use this register.

#### Related Links

[30.3.2.6 Temperature Measurement](#)

### 6.10.2.4 OSC16 Error at 3V

**Name:** OSC16ERR3V  
**Offset:** 0x22  
**Reset:** [Oscillator frequency error value]  
**Property:** -

Bit	7	6	5	4	3	2	1	0
	OSC16ERR3V[7:0]							
Access	R	R	R	R	R	R	R	R
Reset	x	x	x	x	x	x	x	x

**Bits 7:0 – OSC16ERR3V[7:0]** OSC16 Error at 3V

These registers contain the signed oscillator frequency error value when running at internal 16 MHz at 3V, as measured during production.

### 6.10.2.5 OSC16 Error at 5V

**Name:** OSC16ERR5V  
**Offset:** 0x23  
**Reset:** [Oscillator frequency error value]  
**Property:** -

Bit	7	6	5	4	3	2	1	0
	OSC16ERR5V[7:0]							
Access	R	R	R	R	R	R	R	R
Reset	x	x	x	x	x	x	x	x

**Bits 7:0 – OSC16ERR5V[7:0]** OSC16 Error at 5V

These registers contain the signed oscillator frequency error value when running at internal 16 MHz at 5V, as measured during production.

### 6.10.2.6 OSC20 Error at 3V

**Name:** OSC20ERR3V  
**Offset:** 0x24  
**Reset:** [Oscillator frequency error value]  
**Property:** -

Bit	7	6	5	4	3	2	1	0
	OSC20ERR3V[7:0]							
Access	R	R	R	R	R	R	R	R
Reset	x	x	x	x	x	x	x	x

#### Bits 7:0 – OSC20ERR3V[7:0] OSC20 Error at 3V

These registers contain the signed oscillator frequency error value when running at internal 20 MHz at 3V, as measured during production.

### 6.10.2.7 OSC20 Error at 5V

**Name:** OSC20ERR5V  
**Offset:** 0x25  
**Reset:** [Oscillator frequency error value]  
**Property:** -

Bit	7	6	5	4	3	2	1	0
	OSC20ERR5V[7:0]							
Access	R	R	R	R	R	R	R	R
Reset	x	x	x	x	x	x	x	x

**Bits 7:0 – OSC20ERR5V[7:0]** OSC20 Error at 5V

These registers contain the signed oscillator frequency error value when running at internal 20 MHz at 5V, as measured during production.

### 6.10.3 Fuse Summary - FUSE

Offset	Name	Bit Pos.									
0x00	WDTCFG	7:0	WINDOW[3:0]				PERIOD[3:0]				
0x01	BODCFG	7:0	LVL[2:0]			SAMPFREQ	ACTIVE[1:0]		SLEEP[1:0]		
0x02	OSCCFG	7:0	OSCLOCK					FREQSEL[1:0]			
0x03	Reserved										
0x04	TCD0CFG	7:0	CMPDEN	CMPDEN	CMPBEN	CMPAEN	CMPD	CMPC	CMPB	CMPA	
0x05	SYSCFG0	7:0	CRCBOOTDIS	CRCAPPDIS	RESERVED	TOUTDIS	RSTPINCFG[1:0]		RESERVED	EESAVE	
0x06	SYSCFG1	7:0					SUT[2:0]				
0x07	APPEND	7:0	APPEND[7:0]								
0x08	BOOTEND	7:0	BOOTEND[7:0]								
0x09	Reserved										
0x0A	LOCKBIT	7:0	LOCKBIT[7:0]								

### 6.10.4 Fuse Description

### 6.10.4.1 Watchdog Configuration

**Name:** WDTCFG  
**Offset:** 0x00  
**Reset:** -  
**Property:** -

Bit	7	6	5	4	3	2	1	0
	WINDOW[3:0]				PERIOD[3:0]			
Access	R	R	R	R	R	R	R	R
Reset	0	0	0	0	0	0	0	0

**Bits 7:4 – WINDOW[3:0]** Watchdog Window Time-out Period

This value is loaded into the WINDOW bit field of the Watchdog Control A register (WDT.CTRLA) during Reset.

**Bits 3:0 – PERIOD[3:0]** Watchdog Time-out Period

This value is loaded into the PERIOD bit field of the Watchdog Control A register (WDT.CTRLA) during Reset.

### 6.10.4.2 BOD Configuration

**Name:** BODCFG  
**Offset:** 0x01  
**Reset:** -  
**Property:** -

The settings of the BOD will be reloaded from this Fuse after a Power-on Reset. For all other Resets, the BOD configuration remains unchanged.

Bit	7	6	5	4	3	2	1	0
	LVL[2:0]			SAMPFREQ	ACTIVE[1:0]		SLEEP[1:0]	
Access	R	R	R	R	R	R	R	R
Reset	0	0	0	0	0	0	0	0

#### Bits 7:5 – LVL[2:0] BOD Level

This value is loaded into the LVL bit field of the BOD Control B register (BOD.CTRLB) during Reset.

Value	Name	Description
0x0	BODLEVEL0	1.8V
0x1	BODLEVEL1	2.15V
0x2	BODLEVEL2	2.60V
0x3	BODLEVEL3	2.95V
0x4	BODLEVEL4	3.30V
0x5	BODLEVEL5	3.70V
0x6	BODLEVEL6	4.00V
0x7	BODLEVEL7	4.30V

#### Bit 4 – SAMPFREQ BOD Sample Frequency

This value is loaded into the SAMPFREQ bit of the BOD Control A register (BOD.CTRLA) during Reset.

Value	Description
0x0	Sample frequency is 1 kHz
0x1	Sample frequency is 125 Hz

#### Bits 3:2 – ACTIVE[1:0] BOD Operation Mode in Active and Idle

This value is loaded into the ACTIVE bit field of the BOD Control A register (BOD.CTRLA) during Reset.

Value	Description
0x0	Disabled
0x1	Enabled
0x2	Sampled
0x3	Enabled with wake-up halted until BOD is ready

#### Bits 1:0 – SLEEP[1:0] BOD Operation Mode in Sleep

This value is loaded into the SLEEP bit field of the BOD Control A register (BOD.CTRLA) during Reset.

Value	Description
0x0	Disabled
0x1	Enabled



# ATtiny1614

## Memories

Value	Description
0x2	Sampled
0x3	Reserved

### 6.10.4.3 Oscillator Configuration

**Name:** OSCCFG  
**Offset:** 0x02  
**Reset:** -  
**Property:** -

Bit	7	6	5	4	3	2	1	0
	OSCLOCK						FREQSEL[1:0]	
Access	R						R	R
Reset	0						1	0

#### Bit 7 – OSCLOCK Oscillator Lock

This fuse bit is loaded to LOCK in CLKCTRL.OSC20MCALIBB during Reset.

Value	Description
0	Calibration registers of the 20 MHz oscillator are accessible
1	Calibration registers of the 20 MHz oscillator are locked

#### Bits 1:0 – FREQSEL[1:0] Frequency Select

These bits select the operation frequency of the 16/20 MHz internal oscillator (OSC20M) and determine the respective factory calibration values to be written to CAL20M in CLKCTRL.OSC20MCALIBA and TEMPCAL20M in CLKCTRL.OSC20MCALIBB.

Value	Description
0x1	Run at 16 MHz with corresponding factory calibration
0x2	Run at 20 MHz with corresponding factory calibration
Other	Reserved

### 6.10.4.4 Timer Counter Type D Configuration

**Name:** TCD0CFG  
**Offset:** 0x04  
**Reset:** -  
**Property:** -

The bit values of this fuse register are written to the corresponding bits in the TCD.FAULTCTRL register of TCD0 at start-up.

The CMPEN and CMP settings of the TCD will only be reloaded from the FUSE values after a Power-on Reset. For all other resets, the corresponding TCD settings of the device will remain unchanged.

Bit	7	6	5	4	3	2	1	0
	CMPDEN	CMPEN	CMPBEN	CMPAEN	CMPD	CMPC	CMPB	CMPA
Access	R	R	R	R	R	R	R	R
Reset	0	0	0	0	0	0	0	0

#### Bits 4, 5, 6, 7 – CMPEN Compare x Enable

Value	Description
0	Compare x output on Pin is disabled
1	Compare x output on Pin is enabled

#### Bits 0, 1, 2, 3 – CMP Compare x

This bit selects the default state of Compare x after Reset, or when entering debug if FAULTDET is '1'.

Value	Description
0	Compare x default state is 0
1	Compare x default state is 1

### 6.10.4.5 System Configuration 0

**Name:** SYSCFG0  
**Offset:** 0x05  
**Reset:** -  
**Property:** -

Bit	7	6	5	4	3	2	1	0
	CRCBOOTDIS	CRCAPPDIS	RESERVED	TOUTDIS	RSTPINCFG[1:0]		RESERVED	EESAVE
Access	R	R	R	R	R	R	R	R
Reset	1	1	1	1	0	1	1	0

**Bit 7 – CRCBOOTDIS** CRC of Boot Section in Reset Disable

See CRC description for more information about the functionality.

Value	Description
0	Boot section undergoing a CRC before Reset releases
1	No CRC of the boot section before Reset releases

**Bit 6 – CRCAPPDIS** CRC of Application Code Section in Reset Disable

See CRC description for more information about the functionality.

Value	Description
0	Application code section undergoing a CRC before Reset releases
1	No CRC of the application code section before Reset releases

**Bit 5 – RESERVED**

**Bit 4 – TOUTDIS** Time Out Disable

This bit can disable the blocking of NVM writes after POR

The NVM write block is only there the first 16ms -31ms after POR if the PDI/RST/GPIO pin (PA0) is fused to be GPIO or reset. The user should check the NVM busy status or the ready flag before the page buffer can be filled or NVM commands can be issued.

The PA0 output enable a block the first 16ms-31ms after POR if the PDI/RST/GPIO pin (PA0) is fused to be GPIO. This should be added to the documentation at a suitable place.

**Bits 3:2 – RSTPINCFG[1:0]** Reset Pin Configuration

These bits select the Reset/UPDI pin configuration.

Value	Description
0x0	GPIO
0x1	UPDI
0x2	RESET
0x3	reserved

**Bit 1 – RESERVED**

**Bit 0 – EESAVE** EEPROM Save during chip erase

**Note:** If the device is locked the EEPROM is always erased by a chip erase, regardless of this bit.

---

---

Value	Description
0	EEPROM erased during chip erase
1	EEPROM not erased under chip erase

### Related Links

[27. CRCSCAN - Cyclic Redundancy Check Memory Scan](#)

### 6.10.4.6 System Configuration 1

**Name:** SYSCFG1  
**Offset:** 0x06  
**Reset:** -  
**Property:** -

Bit	7	6	5	4	3	2	1	0
						SUT[2:0]		
Access						R	R	R
Reset						1	1	1

#### Bits 2:0 – SUT[2:0] Start-Up Time Setting

These bits select the start-up time between power-on and code execution.

Value	Description
0x0	0 ms
0x1	1 ms
0x2	2 ms
0x3	4 ms
0x4	8 ms
0x5	16 ms
0x6	32 ms
0x7	64 ms

### 6.10.4.7 Application Code End

**Name:** APPEND  
**Offset:** 0x07  
**Reset:** -  
**Property:** -

Bit	7	6	5	4	3	2	1	0
	APPEND[7:0]							
Access	R	R	R	R	R	R	R	R
Reset	0	0	0	0	0	0	0	0

**Bits 7:0 – APPEND[7:0]** Application Code Section End

These bits set the end of the application code section in blocks of 256 bytes. The end of the application code section should be set as BOOT size plus application code size. The remaining Flash will be application data. A value of 0x00 defines the Flash from BOOTEND\*256 to end of Flash as application code. When both FUSE.APPEND and FUSE.BOOTEND are 0x00, the entire Flash is BOOT section.

### 6.10.4.8 Boot End

**Name:** BOOTEND  
**Offset:** 0x08  
**Reset:** -  
**Property:** -

Bit	7	6	5	4	3	2	1	0
	BOOTEND[7:0]							
Access	R	R	R	R	R	R	R	R
Reset	0	0	0	0	0	0	0	0

**Bits 7:0 – BOOTEND[7:0]** Boot Section End

These bits set the end of the boot section in blocks of 256 bytes. A value of 0x00 defines the whole Flash as BOOT section. When both FUSE.APPEND and FUSE.BOOTEND are 0x00, the entire Flash is BOOT section.



### 6.10.4.9 Lockbits

**Name:** LOCKBIT  
**Offset:** 0x0A  
**Reset:** -  
**Property:** -

Bit	7	6	5	4	3	2	1	0
	LOCKBIT[7:0]							
Access	R/W	R/W	R/W	R/W	R/W	R/W	R/W	R/W
Reset	0	0	0	0	0	0	0	0

#### Bits 7:0 – LOCKBIT[7:0] Lockbits

When the part is locked, UPDI cannot access the system bus, so it cannot read out anything but CS-space.

Value	Description
0xC5	Valid key - the device is open
other	Invalid - the device is locked

#### Related Links

[6.9 Memory Section Access from CPU and UPDI on Locked Device](#)

## 7. Peripherals and Architecture

### 7.1 Peripheral Module Address Map

The address map shows the base address for each peripheral. For complete register description and summary for each peripheral module, refer to the respective module chapters.

**Table 7-1. Peripheral Module Address Map**

Base Address	Name	Description
0x0000	VPORTA	Virtual Port A
0x0004	VPORTB	Virtual Port B
0x001C	GPIO	General Purpose I/O registers
0x0030	CPU	CPU
0x0040	RSTCTRL	Reset Controller
0x0050	SLPCTRL	Sleep Controller
0x0060	CLKCTRL	Clock Controller
0x0080	BOD	Brown-Out Detector
0x00A0	VREF	Voltage Reference
0x0100	WDT	Watchdog Timer
0x0110	CPUINT	Interrupt Controller
0x0120	CRCSCAN	Cyclic Redundancy Check Memory Scan
0x0140	RTC	Real-Time Counter
0x0180	EVSYS	Event System
0x01C0	CCL	Configurable Custom Logic
0x0200	PORTMUX	Port Multiplexer
0x0400	PORTA	Port A Configuration
0x0420	PORTB	Port B Configuration
0x0600	ADC0	Analog-to-Digital Converter
0x0640	ADC1	Analog-to-Digital Converter instance 1
0x0680	AC0	Analog Comparator 0
0x0688	AC1	Analog Comparator 1
0x0690	AC2	Analog Comparator 2
0x06A0	DAC0	Digital-to-Analog Converter 0
0x06A8	DAC1	Digital-to-Analog Converter 1

Base Address	Name	Description
0x06B0	DAC2	Digital-to-Analog Converter 2
0x0800	USART0	Universal Synchronous Asynchronous Receiver Transmitter
0x0810	TWI0	Two-Wire Interface
0x0820	SPI0	Serial Peripheral Interface
0x0A00	TCA0	Timer/Counter Type A instance 0
0x0A40	TCB0	Timer/Counter Type B instance 0
0x0A50	TCB1	Timer/Counter Type B 1
0x0A80	TCD0	Timer/Counter Type D instance 0
0x0F00	SYSCFG	System Configuration
0x1000	NVMCTRL	Nonvolatile Memory Controller
0x1100	SIGROW	Signature Row
0x1280	FUSES	Device-specific fuses
0x1300	USERROW	User Row

## 7.2 Interrupt Vector Mapping

Each of the interrupt vectors is connected to one peripheral instance, as shown in the table below. A peripheral can have one or more interrupt sources, see the *Interrupt* section in the *Functional* description of the respective peripheral for more details on the available interrupt sources.

When the interrupt condition occurs, an Interrupt Flag (nameIF) is set in the Interrupt Flags register of the peripheral (*peripheral.INTFLAGS*).

An interrupt is enabled or disabled by writing to the corresponding Interrupt Enable bit (nameIE) in the peripheral's Interrupt Control register (*peripheral.INTCTRL*).

The naming of the registers may vary slightly in some peripherals.

An interrupt request is generated when the corresponding interrupt is enabled and the interrupt flag is set. The interrupt request remains active until the interrupt flag is cleared. See the peripheral's INTFLAGS register for details on how to clear interrupt flags.

Interrupts must be enabled globally for interrupt requests to be generated.

**Table 7-2. Interrupt Vector Mapping**

Vector Number	Base Address	Peripheral Source
0	0x00	RESET
1	0x02	NMI - Non-Maskable Interrupt from CRC
2	0x04	VLM - Voltage Level Monitor
3	0x06	PORTA - Port A

Vector Number	Base Address	Peripheral Source
4	0x08	PORTB - Port B
5	0x0A	PORTC - Port C
6	0x0C	RTC - Real-Time Counter
7	0x0E	PIT - Periodic Interrupt Timer (in RTC peripheral)
8	0x10	TCA0 - Timer Counter Type A
13	0x1A	TCB0 - Timer Counter Type B
14	0x1C	TCB1 - Timer Counter Type B
15	0x1E	TCD0 - Timer Counter Type D
17	0x22	AC0 – Analog Comparator
18	0x24	AC1 – Analog Comparator
19	0x26	AC2 – Analog Comparator
20	0x28	ADC0 – Analog-to-Digital Converter/PTC
22	0x2C	ADC1 – Analog-to-Digital Converter
24	0x30	TWI0 - Two-Wire Interface/I <sup>2</sup> C
26	0x34	SPI0 - Serial Peripheral Interface
27	0x36	USART0 - Universal Asynchronous Receiver-Transmitter
30	0x3C	NVM - Nonvolatile Memory

### Related Links

- [9. NVMCTRL - Nonvolatile Memory Controller](#)
- [16. PORT - I/O Pin Configuration](#)
- [23. RTC - Real-Time Counter](#)
- [25. SPI - Serial Peripheral Interface](#)
- [24. USART - Universal Synchronous and Asynchronous Receiver and Transmitter](#)
- [26. TWI - Two-Wire Interface](#)
- [27. CRCSCAN - Cyclic Redundancy Check Memory Scan](#)
- [20. TCA - 16-bit Timer/Counter Type A](#)
- [21. TCB - 16-bit Timer/Counter Type B](#)
- [22. TCD - 12-Bit Timer/Counter Type D](#)
- [29. AC - Analog Comparator](#)
- [30. ADC - Analog-to-Digital Converter](#)

### **7.3 System Configuration (SYSCFG)**

The system configuration contains the revision ID of the part. The revision ID is readable from the CPU, making it useful for implementing application changes between part revisions.

**7.3.1 Register Summary - SYSCFG**

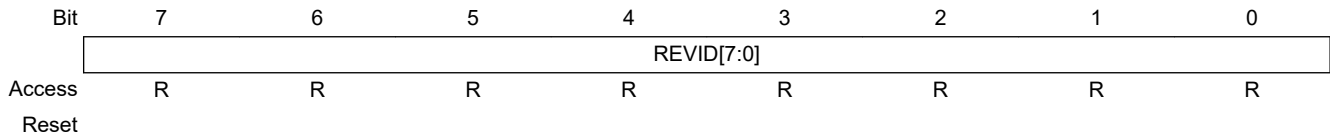
Offset	Name	Bit Pos.								
0x01	REVID	7:0	REVID[7:0]							

**7.3.2 Register Description - SYSCFG**

**7.3.2.1 Device Revision ID Register**

**Name:** REVID  
**Offset:** 0x01  
**Reset:** [revision ID]  
**Property:** -

This register is read-only and displays the device revision ID.



**Bits 7:0 – REVID[7:0] Revision ID**

These bits contain the device revision. 0x00 = A, 0x01 = B, and so on.

## 8. AVR CPU

### 8.1 Features

- 8-Bit, High-Performance AVR RISC CPU:
  - 135 instructions
  - Hardware multiplier
- 32 8-Bit Registers Directly Connected to the Arithmetic Logic Unit (ALU)
- Stack in RAM
- Stack Pointer Accessible in I/O Memory Space
- Direct Addressing of up to 64 KB of Unified Memory:
  - Entire Flash accessible with all `LD/ST` instructions
- True 16/24-Bit Access to 16/24-Bit I/O Registers
- Efficient Support for 8-, 16-, and 32-Bit Arithmetic
- Configuration Change Protection for System Critical Features

### 8.2 Overview

All AVR devices use the 8-bit AVR CPU. The CPU is able to access memories, perform calculations, control peripherals, and execute instructions in the program memory. Interrupt handling is described in a separate section.

#### Related Links

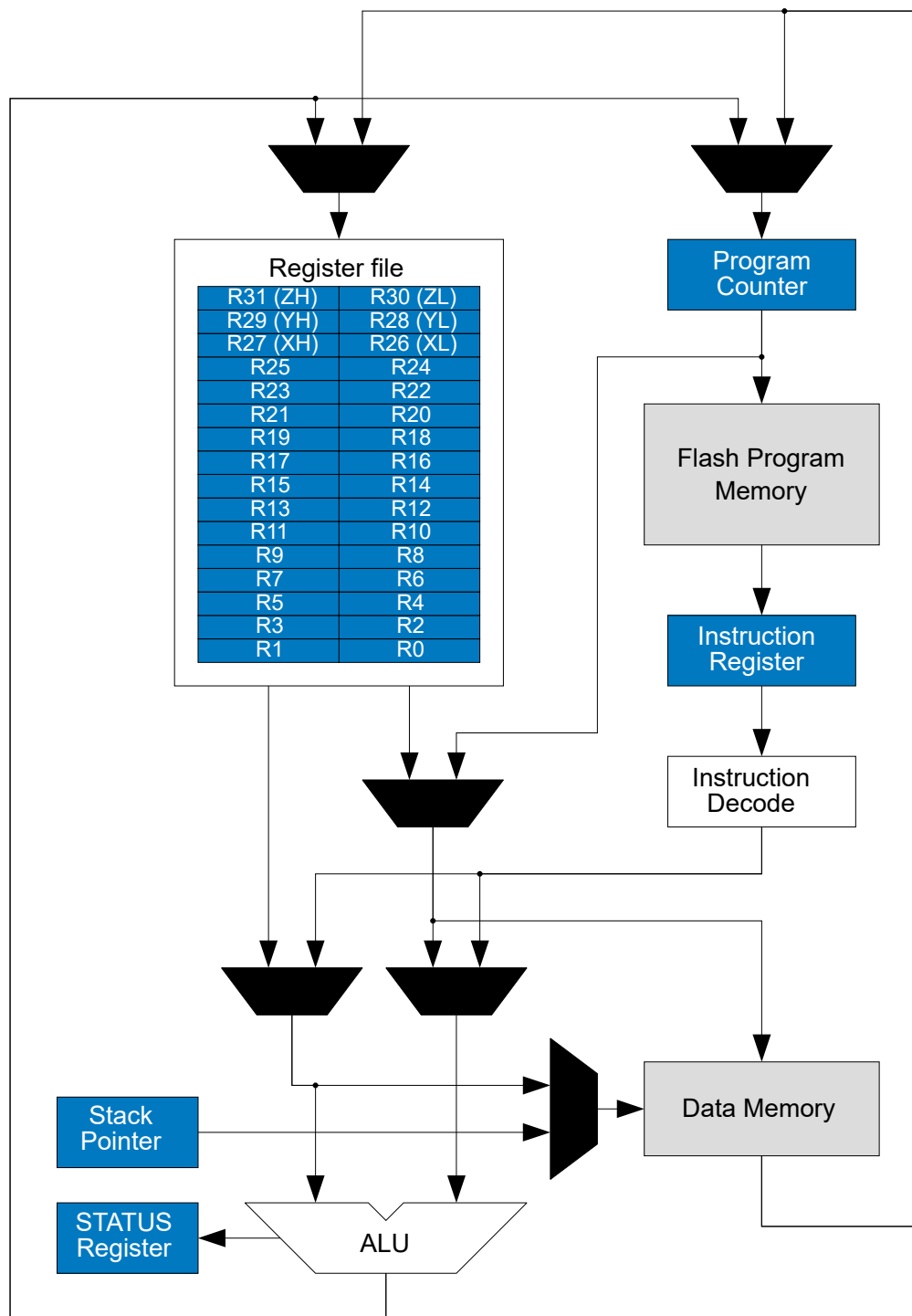
- [6. Memories](#)
- [9. NVMCTRL - Nonvolatile Memory Controller](#)
- [13. CPUINT - CPU Interrupt Controller](#)

### 8.3 Architecture

In order to maximize performance and parallelism, the AVR CPU uses a Harvard architecture with separate buses for program and data. Instructions in the program memory are executed with single-level pipelining. While one instruction is being executed, the next instruction is prefetched from the program memory. This enables instructions to be executed on every clock cycle.



**Figure 8-1. AVR CPU Architecture**



The Arithmetic Logic Unit (ALU) supports arithmetic and logic operations between registers or between a constant and a register. Also, single-register operations can be executed in the ALU. After an arithmetic operation, the STATUS register is updated to reflect information about the result of the operation.

The ALU is directly connected to the fast-access register file. The 32 8-bit general purpose working registers all have single clock cycle access time allowing single-cycle arithmetic logic unit operation

between registers or between a register and an immediate. Six of the 32 registers can be used as three 16-bit Address Pointers for program and data space addressing, enabling efficient address calculations.

The program memory bus is connected to Flash, and the first program memory Flash address is 0x0000.

The data memory space is divided into I/O registers, SRAM, EEPROM, and Flash.

All I/O Status and Control registers reside in the lowest 4 KB addresses of the data memory. This is referred to as the I/O memory space. The lowest 64 addresses are accessed directly with single-cycle `IN/OUT` instructions, or as the data space locations from 0x00 to 0x3F. These addresses can be accessed using load (`LD/LDS/LDD`) and store (`ST/STS/STD`) instructions. The lowest 32 addresses can even be accessed with single-cycle `SBI/CBI` instructions and `SBIS/SBIC` instructions. The rest is the extended I/O memory space, ranging from 0x0040 to 0x0FFF. The I/O registers here must be accessed as data space locations using load and store instructions.

Data addresses 0x1000 to 0x1800 are reserved for memory mapping of fuses, the NVM controller and EEPROM. The addresses from 0x1800 to 0x7FFF are reserved for other memories, such as SRAM.

The Flash is mapped in the data space from 0x8000 and above. The Flash can be accessed with all load and store instructions by using addresses above 0x8000. The `LPM` instruction accesses the Flash similar to the code space, where the Flash starts at address 0x0000.

For a summary of all AVR instructions, refer to the Instruction Set Summary section. For details of all AVR instructions, refer to <http://www.microchip.com/design-centers/8-bit>.

### Related Links

[9. NVMCTRL - Nonvolatile Memory Controller](#)

[6. Memories](#)

[34. Instruction Set Summary](#)

## 8.4 Arithmetic Logic Unit (ALU)

The Arithmetic Logic Unit (ALU) supports arithmetic and logic operations between registers, or between a constant and a register. Also, single-register operations can be executed.

The ALU operates in direct connection with all 32 general purpose registers. Arithmetic operations between general purpose registers or between a register and an immediate are executed in a single clock cycle, and the result is stored in the register file. After an arithmetic or logic operation, the Status register (CPU.SREG) is updated to reflect information about the result of the operation.

ALU operations are divided into three main categories – arithmetic, logical, and bit functions. Both 8- and 16-bit arithmetic are supported, and the instruction set allows for efficient implementation of 32-bit arithmetic. The hardware multiplier supports signed and unsigned multiplication and fractional format.

### 8.4.1 Hardware Multiplier

The multiplier is capable of multiplying two 8-bit numbers into a 16-bit result. The hardware multiplier supports different variations of signed and unsigned integer and fractional numbers:

- Multiplication of signed/unsigned integers
- Multiplication of signed/unsigned fractional numbers
- Multiplication of a signed integer with an unsigned integer
- Multiplication of a signed fractional number with an unsigned one

A multiplication takes two CPU clock cycles.

## 8.5 Functional Description

### 8.5.1 Program Flow

After Reset, the CPU will execute instructions from the lowest address in the Flash program memory, 0x0000. The Program Counter (PC) addresses the next instruction to be fetched.

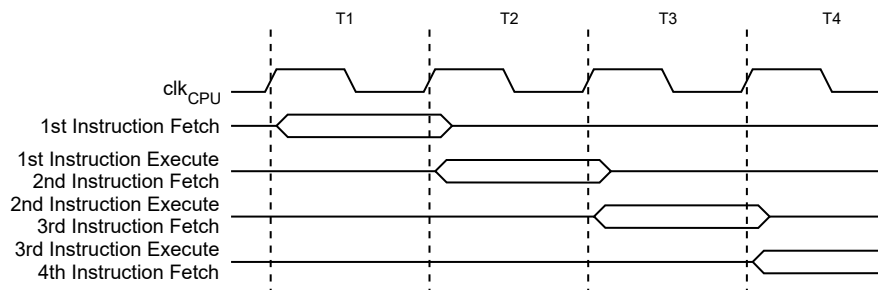
Program flow is supported by conditional and unconditional `JUMP` and `CALL` instructions, capable of addressing the whole address space directly. Most AVR instructions use a 16-bit word format, and a limited number use a 32-bit format.

During interrupts and subroutine calls, the return address PC is stored on the stack as a word pointer. The stack is allocated in the general data SRAM, and consequently, the stack size is only limited by the total SRAM size and the usage of the SRAM. After Reset, the Stack Pointer (SP) points to the highest address in the internal SRAM. The SP is read/write accessible in the I/O memory space, enabling easy implementation of multiple stacks or stack areas. The data SRAM can easily be accessed through the five different addressing modes supported by the AVR CPU.

### 8.5.2 Instruction Execution Timing

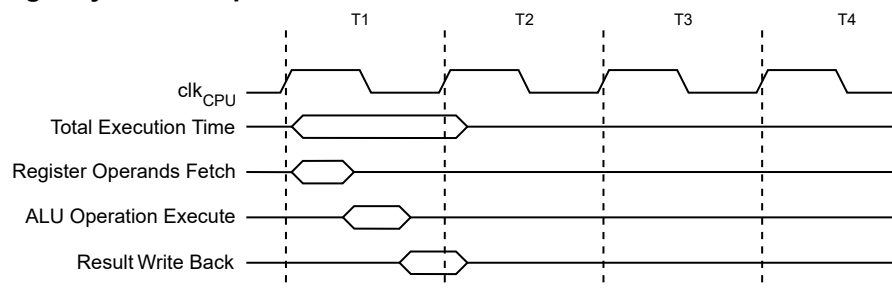
The AVR CPU is clocked by the CPU clock: `CLK_CPU`. No internal clock division is applied. The figure below shows the parallel instruction fetches and instruction executions enabled by the Harvard architecture and the fast-access register file concept. This is the basic pipelining concept enabling up to 1 MIPS/MHz performance with high efficiency.

**Figure 8-2. The Parallel Instruction Fetches and Instruction Executions**



The following figure shows the internal timing concept for the register file. In a single clock cycle, an ALU operation using two register operands is executed and the result is stored in the destination register.

**Figure 8-3. Single Cycle ALU Operation**



### 8.5.3 Status Register

The Status register (CPU.SREG) contains information about the result of the most recently executed arithmetic or logic instruction. This information can be used for altering program flow in order to perform conditional operations.

---

CPU.SREG is updated after all ALU operations, as specified in the Instruction Set Summary. This will in many cases remove the need for using the dedicated compare instructions, resulting in faster and more compact code. CPU.SREG is not automatically stored/restored when entering/returning from an Interrupt Service Routine. Maintaining the Status register between context switches must, therefore, be handled by user-defined software. CPU.SREG is accessible in the I/O memory space.

### Related Links

[34. Instruction Set Summary](#)

#### 8.5.4 Stack and Stack Pointer

The stack is used for storing return addresses after interrupts and subroutine calls. Also, it can be used for storing temporary data. The Stack Pointer (SP) always points to the top of the stack. The SP is defined by the Stack Pointer bits in the Stack Pointer register (CPU.SP). The CPU.SP is implemented as two 8-bit registers that are accessible in the I/O memory space.

Data is pushed and popped from the stack using the `PUSH` and `POP` instructions. The stack grows from higher to lower memory locations. This implies that pushing data onto the stack decreases the SP, and popping data off the stack increases the SP. The Stack Pointer is automatically set to the highest address of the internal SRAM after Reset. If the stack is changed, it must be set to point above address 0x2000, and it must be defined before any subroutine calls are executed and before interrupts are enabled.

During interrupts or subroutine calls the return address is automatically pushed on the stack as a word pointer and the SP is decremented by '2'. The return address consists of two bytes and the Least Significant Byte is pushed on the stack first (at the higher address). As an example, a byte pointer return address of 0x0006 is saved on the stack as 0x0003 (shifted one bit to the right), pointing to the fourth 16-bit instruction word in the program memory. The return address is popped off the stack with `RETI` (when returning from interrupts) and `RET` (when returning from subroutine calls) and the SP is incremented by two.

The SP is decremented by '1' when data is pushed on the stack with the `PUSH` instruction, and incremented by '1' when data is popped off the stack using the `POP` instruction.

To prevent corruption when updating the Stack Pointer from software, a write to SPL will automatically disable interrupts for up to four instructions or until the next I/O memory write.

#### 8.5.5 Register File

The register file consists of 32 8-bit general purpose working registers with single clock cycle access time. The register file supports the following input/output schemes:

- One 8-bit output operand and one 8-bit result input
- Two 8-bit output operands and one 8-bit result input
- Two 8-bit output operands and one 16-bit result input
- One 16-bit output operand and one 16-bit result input

Six of the 32 registers can be used as three 16-bit Address Register Pointers for data space addressing, enabling efficient address calculations.

**Figure 8-4. AVR CPU General Purpose Working Registers**

7		0	Addr.	
	R0			0x00
	R1			0x01
	R2			0x02
	...			
	R13			0x0D
	R14			0x0E
	R15			0x0F
	R16			0x10
	R17			0x11
	...			
	R26		0x1A	X-register Low Byte
	R27		0x1B	X-register High Byte
	R28		0x1C	Y-register Low Byte
	R29		0x1D	Y-register High Byte
	R30		0x1E	Z-register Low Byte
	R31		0x1F	Z-register High Byte

The register file is located in a separate address space and is, therefore, not accessible through instructions operation on data memory.

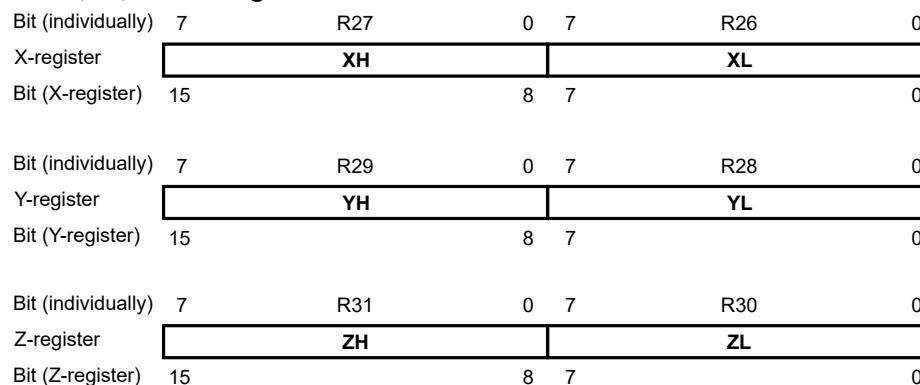
### 8.5.5.1 The X-, Y-, and Z-Registers

Registers R26...R31 have added functions besides their general purpose usage.

These registers can form 16-bit Address Pointers for addressing data memory. These three address registers are called the X-register, Y-register, and Z-register. Load and store instructions can use all X-, Y-, and Z-registers, while the `LPM` instructions can only use the Z-register. Indirect calls and jumps (`ICALL` and `IJMP`) also use the Z-register.

Refer to the instruction set or Instruction Set Summary for more information about how the X-, Y-, and Z-registers are used.

**Figure 8-5. The X-, Y-, and Z-Registers**



The lowest register address holds the Least Significant Byte (LSB), and the highest register address holds the Most Significant Byte (MSB). In the different addressing modes, these address registers function as fixed displacement, automatic increment, and automatic decrement.

### Related Links

[34. Instruction Set Summary](#)

### 8.5.6 Accessing 16-Bit Registers

The AVR data bus has a width of 8 bits, and so accessing 16-bit registers requires atomic operations. These registers must be byte accessed using two read or write operations. 16-bit registers are connected to the 8-bit bus and a temporary register using a 16-bit bus.

For a write operation, the low byte of the 16-bit register must be written before the high byte. The low byte is then written into the temporary register. When the high byte of the 16-bit register is written, the temporary register is copied into the low byte of the 16-bit register in the same clock cycle.

For a read operation, the low byte of the 16-bit register must be read before the high byte. When the low byte register is read by the CPU, the high byte of the 16-bit register is copied into the temporary register in the same clock cycle as the low byte is read. When the high byte is read, it is then read from the temporary register.

This ensures that the low and high bytes of 16-bit registers are always accessed simultaneously when reading or writing the register.

Interrupts can corrupt the timed sequence if an interrupt is triggered and accesses the same 16-bit register during an atomic 16-bit read/write operation. To prevent this, interrupts can be disabled when writing or reading 16-bit registers.

The temporary registers can be read and written directly from user software.

#### 8.5.6.1 Accessing 24-Bit Registers

For 24-bit registers, the read and write access is done in the same way as described for 16-bit registers, except there are two temporary registers for 24-bit registers. The Least Significant Byte must be written first when doing a write, and read first when doing a read.

### 8.5.7 Configuration Change Protection (CCP)

System critical I/O register settings are protected from accidental modification. Flash self-programming (via store to NVM controller) is protected from accidental execution. This is handled globally by the Configuration Change Protection (CCP) register.

Changes to the protected I/O registers or bits, or execution of protected instructions, are only possible after the CPU writes a signature to the CCP register. The different signatures are listed in the description of the CCP register (CPU.CCP).

There are two modes of operation: one for protected I/O registers, and one for the protected self-programming.

#### Related Links

##### [8.7.1 CCP](#)

#### 8.5.7.1 Sequence for Write Operation to Configuration Change Protected I/O Registers

In order to write to registers protected by CCP, these steps are required:

1. The software writes the signature that enables change of protected I/O registers to the CCP bit field in the CPU.CCP register.
2. Within four instructions, the software must write the appropriate data to the protected register. Most protected registers also contain a write enable/change enable/lock bit. This bit must be written to '1' in the same operation as the data are written.

The protected change is immediately disabled if the CPU performs write operations to the I/O register or data memory, if load or store accesses to Flash, NVMCTRL, EEPROM are conducted, or if the `SLEEP` instruction is executed.

### **8.5.7.2 Sequence for Execution of Self-Programming**

In order to execute self-programming (the execution of writes to the NVM controller's command register), the following steps are required:

1. The software temporarily enables self-programming by writing the SPM signature to the CCP register (CPU.CCP).
2. Within four instructions, the software must execute the appropriate instruction. The protected change is immediately disabled if the CPU performs accesses to the Flash, NVMCTRL, or EEPROM, or if the `SLEEP` instruction is executed.

Once the correct signature is written by the CPU, interrupts will be ignored for the duration of the configuration change enable period. Any interrupt request (including non-maskable interrupts) during the CCP period will set the corresponding interrupt flag as normal, and the request is kept pending. After the CCP period is completed, any pending interrupts are executed according to their level and priority.

## 8.6 Register Summary - CPU

Offset	Name	Bit Pos.									
0x04	CCP	7:0	CCP[7:0]								
0x05	Reserved										
...											
0x0C											
0x0D	SP	7:0	SP[7:0]								
		15:8	SP[15:8]								
0x0F	SREG	7:0	I	T	H	S	V	N	Z	C	

## 8.7 Register Description



### 8.7.1 Configuration Change Protection

**Name:** CCP  
**Offset:** 0x04  
**Reset:** 0x00  
**Property:** -

Bit	7	6	5	4	3	2	1	0
	CCP[7:0]							
Access	R/W	R/W	R/W	R/W	R/W	R/W	R/W	R/W
Reset	0	0	0	0	0	0	0	0

**Bits 7:0 – CCP[7:0]** Configuration Change Protection

Writing the correct signature to this bit field allows changing protected I/O registers or executing protected instructions within the next four CPU instructions executed.

All interrupts are ignored during these cycles. After these cycles, interrupts will automatically be handled again by the CPU, and any pending interrupts will be executed according to their level and priority.

When the protected I/O register signature is written, CCP[0] will read as '1' as long as the CCP feature is enabled.

When the protected self-programming signature is written, CCP[1] will read as '1' as long as the CCP feature is enabled.

CCP[7:2] will always read as zero.

Value	Name	Description
0x9D	SPM	Allow Self-Programming
0xD8	IOREG	Un-protect protected I/O registers

### 8.7.2 Stack Pointer

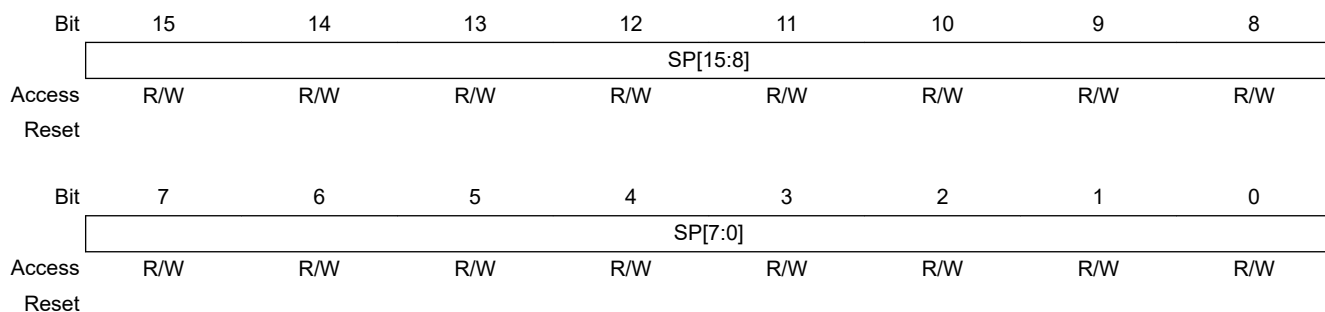
**Name:** SP  
**Offset:** 0x0D  
**Reset:** Top of stack  
**Property:** -

The CPU.SP holds the Stack Pointer (SP) that points to the top of the stack. After Reset, the Stack Pointer points to the highest internal SRAM address.

Only the number of bits required to address the available data memory including external memory (up to 64 KB) is implemented for each device. Unused bits will always read as zero.

The CPU.SPL and CPU.SPH register pair represents the 16-bit value, CPU.SP. The low byte [7:0] (suffix L) is accessible at the original offset. The high byte [15:8] (suffix H) can be accessed at offset + 0x01.

To prevent corruption when updating the SP from software, a write to CPU.SPL will automatically disable interrupts for the next four instructions or until the next I/O memory write.



**Bits 15:8 – SP[15:8] Stack Pointer High Byte**  
 These bits hold the MSB of the 16-bit register.

**Bits 7:0 – SP[7:0] Stack Pointer Low Byte**  
 These bits hold the LSB of the 16-bit register.

### 8.7.3 Status Register

**Name:** SREG  
**Offset:** 0x0F  
**Reset:** 0x00  
**Property:** -

The Status register contains information about the result of the most recently executed arithmetic or logic instruction. For details about the bits in this register and how they are affected by the different instructions, see the Instruction Set Summary.

Bit	7	6	5	4	3	2	1	0
	I	T	H	S	V	N	Z	C
Access	R/W	R/W	R/W	R/W	R/W	R/W	R/W	R/W
Reset	0	0	0	0	0	0	0	0

#### Bit 7 – I Global Interrupt Enable

Writing a '1' to this bit enables interrupts on the device.

Writing a '0' to this bit disables interrupts on the device, independent of the individual interrupt enable settings of the peripherals.

This bit is not cleared by hardware after an interrupt has occurred.

This bit can be set and cleared by software with the `SEI` and `CLI` instructions.

Changing the I flag through the I/O register results in a one-cycle Wait state on the access.

#### Bit 6 – T Bit Copy Storage

The bit copy instructions bit load (`BLD`) and bit store (`BST`) use the T bit as source or destination for the operated bit.

A bit from a register in the register file can be copied into this bit by the `BST` instruction, and this bit can be copied into a bit in a register in the register file by the `BLD` instruction.

#### Bit 5 – H Half Carry Flag

This bit indicates a half carry in some arithmetic operations. Half carry is useful in BCD arithmetic.

#### Bit 4 – S Sign Bit, $S = N \oplus V$

The sign bit (S) is always an exclusive or (*xor*) between the negative flag (N) and the two's complement overflow flag (V).

#### Bit 3 – V Two's Complement Overflow Flag

The two's complement overflow flag (V) supports two's complement arithmetic.

#### Bit 2 – N Negative Flag

The negative flag (N) indicates a negative result in an arithmetic or logic operation.

#### Bit 1 – Z Zero Flag

The zero flag (Z) indicates a zero result in an arithmetic or logic operation.

**Bit 0 – C** Carry Flag

The carry flag (C) indicates a carry in an arithmetic or logic operation.

## 9. NVMCTRL - Nonvolatile Memory Controller

### 9.1 Features

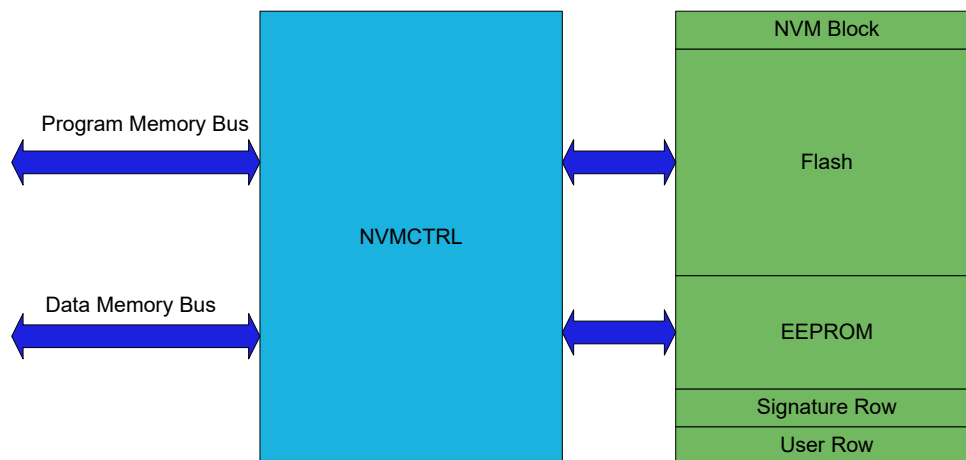
- Unified Memory
- In-System Programmable
- Self-Programming and Boot Loader Support
- Configurable Sections for Write Protection:
  - Boot section for boot loader code or application code
  - Application code section for application code
  - Application data section for application code or data storage
- Signature Row for Factory-Programmed Data:
  - ID for each device type
  - Serial number for each device
  - Calibration bytes for factory calibrated peripherals
- User Row for Application Data:
  - 32 bytes in size
  - Can be read and written from software
  - Can be written from UPDI on locked device
  - Content is kept after chip erase

### 9.2 Overview

The NVM Controller (NVMCTRL) is the interface between the device, the Flash, and the EEPROM. The Flash and EEPROM are reprogrammable memory blocks that retain their values even when not powered. The Flash is mainly used for program storage and can be used for data storage. The EEPROM is used for data storage and can be programmed while the CPU is running the program from the Flash.

#### 9.2.1 Block Diagram

**Figure 9-1. NVMCTRL Block Diagram**



### 9.2.2 System Dependencies

In order to use this peripheral, other parts of the system must be configured correctly, as described below.

**Table 9-1. NVMCTRL System Dependencies**

Dependency	Applicable	Peripheral
Clocks	Yes	CLKCTRL
I/O Lines and Connections	No	-
Interrupts	Yes	CPUINT
Events	No	-
Debug	Yes	UPDI

#### Related Links

[9.2.2.1 Clocks](#)

[9.2.2.5 Debug Operation](#)

[9.2.2.3 Interrupts](#)

#### 9.2.2.1 Clocks

This peripheral always runs on the CPU clock (CLK\_CPU). It will request this clock also in sleep modes if a write/erase is ongoing.

#### Related Links

[10. CLKCTRL - Clock Controller](#)

#### 9.2.2.2 I/O Lines and Connections

Not applicable.

#### 9.2.2.3 Interrupts

Using the interrupts of this peripheral requires the interrupt controller to be configured first.

#### 9.2.2.4 Events

Not applicable.

#### 9.2.2.5 Debug Operation

When run-time debugging, this peripheral will continue normal operation. Halting the CPU in Debugging mode will halt normal operation of the peripheral.

If the peripheral is configured to require periodical service by the CPU through interrupts or similar, improper operation or data loss may result during halted debugging.

#### Related Links

[33. UPDI - Unified Program and Debug Interface](#)

## 9.3 Functional Description

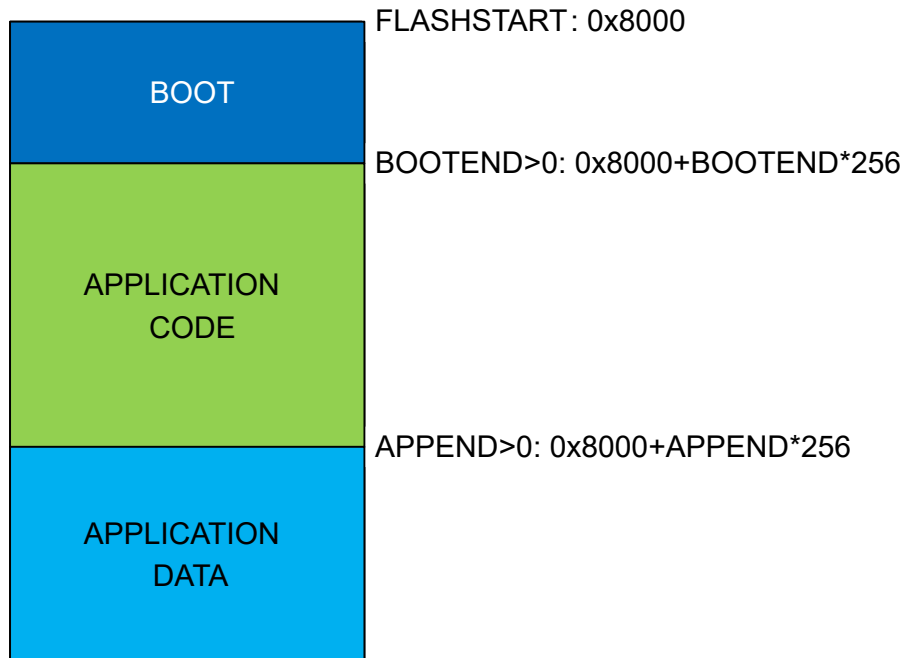
### 9.3.1 Memory Organization

#### 9.3.1.1 Flash

The Flash is divided into a set of pages. A page is the basic unit addressed when programming the Flash. It is only possible to write or erase a whole page at a time. One page consists of several words.

The Flash can be divided into three sections in blocks of 256 bytes for different security. The three different sections are BOOT, Application Code (APPCODE), and Application Data (APPDATA).

**Figure 9-2. Flash Sections**



### Section Sizes

The sizes of these sections are set by the Boot Section End fuse (FUSE.BOOTEND) and Application Code Section End fuse (FUSE.APPEND).

The fuses select the section sizes in blocks of 256 bytes. The BOOT section stretches from the start of the Flash until BOOTEND. The APPCODE section runs from BOOTEND until APPEND. The remaining area is the APPDATA section. If APPEND is written to 0, the APPCODE section runs from BOOTEND to the end of Flash (removing the APPDATA section). If BOOTEND and APPEND are written to 0, the entire Flash is regarded as BOOT section. APPEND should either be set to 0 or a value greater or equal than BOOTEND.

**Table 9-2. Setting Up Flash Sections**

BOOTEND	APPEND	BOOT Section	APPCODE Section	APPDATA Section
0	0	0 to FLASHEND	-	-
> 0	0	0 to 256*BOOTEND	256*BOOTEND to FLASHEND	-
> 0	== BOOTEND	0 to 256*BOOTEND	-	256*BOOTEND to FLASHEND
> 0	> BOOTEND	0 to 256*BOOTEND	256*BOOTEND to 256*APPEND	256*APPEND to FLASHEND

### Note:

- See also the BOOTEND and APPEND descriptions.

- Interrupt vectors are by default located after the BOOT section. This can be changed in the interrupt controller.

If FUSE.BOOTEND is written to 0x04 and FUSE.APPEND is written to 0x08, the first 4\*256 bytes will be BOOT, the next 4\*256 bytes will be APPCODE, and the remaining Flash will be APPDATA.

### Inter-Section Write Protection

Between the three Flash sections, a directional write protection is implemented:

- The code in the BOOT section can write to APPCODE and APPDATA
- The code in APPCODE can write to APPDATA
- The code in APPDATA cannot write to Flash or EEPROM

### Boot Section Lock and Application Code Section Write Protection

The two lockbits (APCWP and BOOTLOCK in NVMCTRL.CTRLB) can be set to lock further updates of the respective APPCODE or BOOT section until the next Reset.

The CPU can never write to the BOOT section. NVMCTRL\_CTRLB.BOOTLOCK prevents reads and execution of code from the BOOT section.

#### 9.3.1.2 EEPROM

The EEPROM is divided into a set of pages where one page consists of multiple bytes. The EEPROM has byte granularity on erase/write. Within one page only the bytes marked to be updated will be erased/written. The byte is marked by writing a new value to the page buffer for that address location.

#### 9.3.1.3 User Row

The User Row is one extra page of EEPROM. This page can be used to store various data, such as calibration/configuration data and serial numbers. This page is not erased by a chip erase. The User Row is written as normal EEPROM, but in addition, it can be written through UPDI on a locked device.

### 9.3.2 Memory Access

#### 9.3.2.1 Read

Reading of the Flash and EEPROM is done by using load instructions with an address according to the memory map. Reading any of the arrays while a write or erase is in progress will result in a bus wait, and the instruction will be suspended until the ongoing operation is complete.

#### 9.3.2.2 Page Buffer Load

The page buffer is loaded by writing directly to the memories as defined in the memory map. Flash, EEPROM, and User Row share the same page buffer so only one section can be programmed at a time. The Least Significant bits (LSb) of the address are used to select where in the page buffer the data is written. The resulting data will be a binary and operation between the new and the previous content of the page buffer. The page buffer will automatically be erased (all bits set) after:

- A device Reset
- Any page write or erase operation
- A Clear Page Buffer command
- The device wakes up from any sleep mode

#### 9.3.2.3 Programming

For page programming, filling the page buffer and writing the page buffer into Flash, User Row, and EEPROM are two separate operations.



Before programming a Flash page with the data in the page buffer, the Flash page must be erased. The page buffer is also erased when the device enters a sleep mode. Programming an unerased Flash page will corrupt its content.

The Flash can either be written with the erase and write separately, or one command handling both:

Alternative 1:

- Fill the page buffer
- Write the page buffer to Flash with the Erase/Write Page command

Alternative 2:

- Write to a location on the page to set up the address
- Perform an Erase Page command
- Fill the page buffer
- Perform a Write Page command

The NVM command set supports both a single erase and write operation, and split Page Erase and Page Write commands. This split commands enable shorter programming time for each command, and the erase operations can be done during non-time-critical programming execution.

The EEPROM programming is similar, but only the bytes updated in the page buffer will be written or erased in the EEPROM.

#### **9.3.2.4 Commands**

Reading of the Flash/EEPROM and writing of the page buffer is handled with normal load/store instructions. Other operations, such as writing and erasing the memory arrays, are handled by commands in the NVM.

To execute a command in the NVM:

1. Confirm that any previous operation is completed by reading the Busy Flags (EEBUSY and FBUSY) in the NVMCTRL.STATUS register.
2. Write the NVM command unlock to the Configuration Change Protection register in the CPU (CPU.CCP).
3. Write the desired command value to the CMD bits in the Control A register (NVMCTRL.CTRLA) within the next four instructions.

##### **9.3.2.4.1 Write Command**

The Write command of the Flash controller writes the content of the page buffer to the Flash or EEPROM.

If the write is to the Flash, the CPU will stop executing code as long as the Flash is busy with the write operation. If the write is to the EEPROM, the CPU can continue executing code while the operation is ongoing.

The page buffer will be automatically cleared after the operation is finished.

##### **9.3.2.4.2 Erase Command**

The Erase command erases the current page. There must be one byte written in the page buffer for the Erase command to take effect.

For erasing the Flash, first, write to one address in the desired page, then execute the command. The whole page in the Flash will then be erased. The CPU will be halted while the erase is ongoing.

For the EEPROM, only the bytes written in the page buffer will be erased when the command is executed. To erase a specific byte, write to its corresponding address before executing the command. To

erase a whole page all the bytes in the page buffer have to be updated before executing the command. The CPU can continue running code while the operation is ongoing.

The page buffer will automatically be cleared after the operation is finished.

### 9.3.2.4.3 Erase-Write Operation

The Erase/Write command is a combination of the Erase and Write command, but without clearing the page buffer after the Erase command: The erase/write operation first erases the selected page, then it writes the content of the page buffer to the same page.

When executed on the Flash, the CPU will be halted when the operations are ongoing. When executed on EEPROM, the CPU can continue executing code.

The page buffer will automatically be cleared after the operation is finished.

### 9.3.2.4.4 Page Buffer Clear Command

The Page Buffer Clear command clears the page buffer. The contents of the page buffer will be all 1's after the operation. The CPU will be halted when the operation executes (seven CPU cycles).

### 9.3.2.4.5 Chip Erase Command

The Chip Erase command erases the Flash and the EEPROM. The EEPROM is unaltered if the EEPROM Save During Chip Erase (EESAVE) fuse in FUSE.SYSCFG0 is set. The Flash will not be protected by Boot Section Lock (BOOTLOCK) or Application Code Section Write Protection (APCWP) in NVMCTRL.CTRLB. The memory will be all 1's after the operation.

### 9.3.2.4.6 EEPROM Erase Command

The EEPROM Erase command erases the EEPROM. The EEPROM will be all 1's after the operation. The CPU will be halted while the EEPROM is being erased.

### 9.3.2.4.7 Fuse Write Command

The Fuse Write command writes the fuses. It can only be used by the UPDI, the CPU cannot start this command.

Follow this procedure to use this command:

- Write the address of the fuse to the Address register (NVMCTRL.ADDR)
- Write the data to be written to the fuse to the Data register (NVMCTRL.DATA)
- Execute the Fuse Write command.
- After the fuse is written, a Reset is required for the updated value to take effect.

For reading fuses, use a regular read on the memory location.

## 9.3.3 Preventing Flash/EEPROM Corruption

During periods of low  $V_{DD}$ , the Flash program or EEPROM data can be corrupted if the supply voltage is too low for the CPU and the Flash/EEPROM to operate properly. These issues are the same as for board level systems using Flash/EEPROM, and the same design solutions should be applied.

A Flash/EEPROM corruption can be caused by two situations when the voltage is too low:

1. A regular write sequence to the Flash, which requires a minimum voltage to operate correctly.
2. The CPU itself can execute instructions incorrectly when the supply voltage is too low.

See the Electrical Characteristics chapter for Maximum Frequency vs.  $V_{DD}$ .

Flash/EEPROM corruption can be avoided by these measures:

- Keep the device in Reset during periods of insufficient power supply voltage. This can be done by enabling the internal Brown-Out Detector (BOD).

- The voltage level monitor in the BOD can be used to prevent starting a write to the EEPROM close to the BOD level.
- If the detection levels of the internal BOD don't match the required detection level, an external low  $V_{DD}$  Reset protection circuit can be used. If a Reset occurs while a write operation is ongoing, the write operation will be aborted.

### Related Links

[37.3 General Operating Ratings](#)

[17. BOD - Brown-out Detector](#)

### 9.3.4 Interrupts

**Table 9-3. Available Interrupt Vectors and Sources**

Offset	Name	Vector Description	Conditions
0x00	EEREADY	NVM	The EEPROM is ready for new write/erase operations.

When an interrupt condition occurs, the corresponding interrupt flag is set in the Interrupt Flags register of the peripheral (NVMCTRL.INTFLAGS).

An interrupt source is enabled or disabled by writing to the corresponding bit in the peripheral's Interrupt Enable register (NVMCTRL.INTEN).

An interrupt request is generated when the corresponding interrupt source is enabled and the interrupt flag is set. The interrupt request remains active until the interrupt flag is cleared. See the peripheral's INTFLAGS register for details on how to clear interrupt flags.

### 9.3.5 Sleep Mode Operation

If there is no ongoing write operation, the NVMCTRL will enter sleep mode when the system enters sleep mode.

If a write operation is ongoing when the system enters a sleep mode, the NVM block, the NVM Controller, and the system clock will remain ON until the write is finished. This is valid for all sleep modes, including Power-Down Sleep mode.

The EEPROM Ready interrupt will wake up the device only from Idle Sleep mode.

The page buffer is cleared when waking up from Sleep.

### 9.3.6 Configuration Change Protection

This peripheral has registers that are under Configuration Change Protection (CCP). In order to write to these, a certain key must be written to the CPU.CCP register first, followed by a write access to the protected bits within four CPU instructions.

Attempting to write to a protected register without following the appropriate CCP unlock sequence leaves the protected register unchanged.

The following registers are under CCP:

**Table 9-4. NVMCTRL - Registers under Configuration Change Protection**

Register	Key
NVMCTRL.CTRLA	SPM

### Related Links

[8.5.7.2 Sequence for Execution of Self-Programming](#)

### 9.4 Register Summary - NVMCTRL

Offset	Name	Bit Pos.								
0x00	CTRLA	7:0							CMD[2:0]	
0x01	CTRLB	7:0							BOOTLOCK	APCWP
0x02	STATUS	7:0						WRERROR	EEBUSY	FBUSY
0x03	INTCTRL	7:0								EEREADY
0x04	INTFLAGS	7:0								EEREADY
0x05	Reserved									
0x06	DATA	7:0	DATA[7:0]							
		15:8	DATA[15:8]							
0x08	ADDR	7:0	ADDR[7:0]							
		15:8	ADDR[15:8]							

### 9.5 Register Description

### 9.5.1 Control A

**Name:** CTRLA  
**Offset:** 0x00  
**Reset:** 0x00  
**Property:** Configuration Change Protection

Bit	7	6	5	4	3	2	1	0
						CMD[2:0]		
Access						R/W	R/W	R/W
Reset						0	0	0

#### Bits 2:0 – CMD[2:0] Command

Write this bit field to issue a command. The Configuration Change Protection key for self-programming (SPM) has to be written within four instructions before this write.

Value	Name	Description
0x0	-	No command
0x1	WP	Write page buffer to memory (NVMCTRL.ADDR selects which memory)
0x2	ER	Erase page (NVMCTRL.ADDR selects which memory)
0x3	ERWP	Erase and write page (NVMCTRL.ADDR selects which memory)
0x4	PBC	Page buffer clear
0x5	CHER	Chip erase: erase Flash and EEPROM (unless EESAVE in FUSE.SYSCFG is '1')
0x6	EEER	EEPROM Erase
0x7	WFU	Write fuse (only accessible through UPDI)

### 9.5.2 Control B

**Name:** CTRLB  
**Offset:** 0x01  
**Reset:** 0x00  
**Property:** -

Bit	7	6	5	4	3	2	1	0
							BOOTLOCK	APCWP
Access							R/W	R/W
Reset							0	0

#### Bit 1 – BOOTLOCK Boot Section Lock

Writing a '1' to this bit locks the boot section from read and instruction fetch.

If this bit is '1', a read from the boot section will return '0'. A fetch from the boot section will also return '0' as instruction.

This bit can be written from the boot section only. It can only be cleared to '0' by a Reset.

This bit will take effect only when the boot section is left the first time after the bit is written.

#### Bit 0 – APCWP Application Code Section Write Protection

Writing a '1' to this bit protects the application code section from further writes.

This bit can only be written to '1'. It is cleared to '0' only by Reset.

### 9.5.3 Status

**Name:** STATUS  
**Offset:** 0x02  
**Reset:** 0x00  
**Property:** -

Bit	7	6	5	4	3	2	1	0
						WRERROR	EEBUSY	FBUSY
Access						R	R	R
Reset						0	0	0

**Bit 2 – WRERROR** Write Error

This bit will read '1' when a write error has happened. A write error could be writing to different sections before doing a page write or writing to a protected area. This bit is valid for the last operation.

**Bit 1 – EEBUSY** EEPROM Busy

This bit will read '1' when the EEPROM is busy with a command.

**Bit 0 – FBUSY** Flash Busy

This bit will read '1' when the Flash is busy with a command.



### 9.5.4 Interrupt Control

**Name:** INTCTRL  
**Offset:** 0x03  
**Reset:** 0x00  
**Property:** -

Bit	7	6	5	4	3	2	1	0
								EEREADY
Access								R/W
Reset								0

#### Bit 0 – EEREADY EEPROM Ready Interrupt

Writing a '1' to this bit enables the interrupt, which indicates that the EEPROM is ready for new write/erase operations.

This is a level interrupt that will be triggered only when the EEREADY flag in the INTFLAGS register is set to zero. Thus, the interrupt should not be enabled before triggering an NVM command, as the EEREADY flag will not be set before the NVM command issued. The interrupt should be disabled in the interrupt handler.

### 9.5.5 Interrupt Flags

**Name:** INTFLAGS  
**Offset:** 0x04  
**Reset:** 0x00  
**Property:** -

Bit	7	6	5	4	3	2	1	0
								EEREADY
Access								R/W
Reset								0

#### Bit 0 – EEREADY EEREADY Interrupt Flag

This flag is set continuously as long as the EEPROM is not busy. This flag is cleared by writing a '1' to it.

### 9.5.6 Data

**Name:** DATA  
**Offset:** 0x06  
**Reset:** 0x00  
**Property:** -

The NVMCTRL.DATAL and NVMCTRL.DATAH register pair represents the 16-bit value, NVMCTRL.DATA. The low byte [7:0] (suffix L) is accessible at the original offset. The high byte [15:8] (suffix H) can be accessed at offset + 0x01.

Bit	15	14	13	12	11	10	9	8
	DATA[15:8]							
Access	R/W	R/W	R/W	R/W	R/W	R/W	R/W	R/W
Reset	0	0	0	0	0	0	0	0
Bit	7	6	5	4	3	2	1	0
	DATA[7:0]							
Access	R/W	R/W	R/W	R/W	R/W	R/W	R/W	R/W
Reset	0	0	0	0	0	0	0	0

#### Bits 15:0 – DATA[15:0] Data Register

This register is used by the UPDI for fuse write operations.

### 9.5.7 Address

**Name:** ADDR  
**Offset:** 0x08  
**Reset:** 0x00  
**Property:** -

The NVMCTRL.ADDRL and NVMCTRL.ADDRH register pair represents the 16-bit value, NVMCTRL.ADDR. The low byte [7:0] (suffix L) is accessible at the original offset. The high byte [15:8] (suffix H) can be accessed at offset + 0x01.

Bit	15	14	13	12	11	10	9	8
	ADDR[15:8]							
Access	R/W	R/W	R/W	R/W	R/W	R/W	R/W	R/W
Reset	0	0	0	0	0	0	0	0
Bit	7	6	5	4	3	2	1	0
	ADDR[7:0]							
Access	R/W	R/W	R/W	R/W	R/W	R/W	R/W	R/W
Reset	0	0	0	0	0	0	0	0

#### Bits 15:0 – ADDR[15:0] Address

The Address register contains the address to the last memory location that has been updated.

## 10. CLKCTRL - Clock Controller

### 10.1 Features

- All clocks and clock sources are automatically enabled when requested by peripherals
- Internal Oscillators:
  - 16/20 MHz Oscillator (OSC20M)
  - 32 KHz Ultra Low-Power Oscillator (OSCULP32K)
- External Clock Options:
  - 32.768 kHz Crystal Oscillator (XOSC32K)
  - External clock
- Main Clock Features:
  - Safe run-time switching
  - Prescaler with 1x to 64x division in 12 different settings

### 10.2 Overview

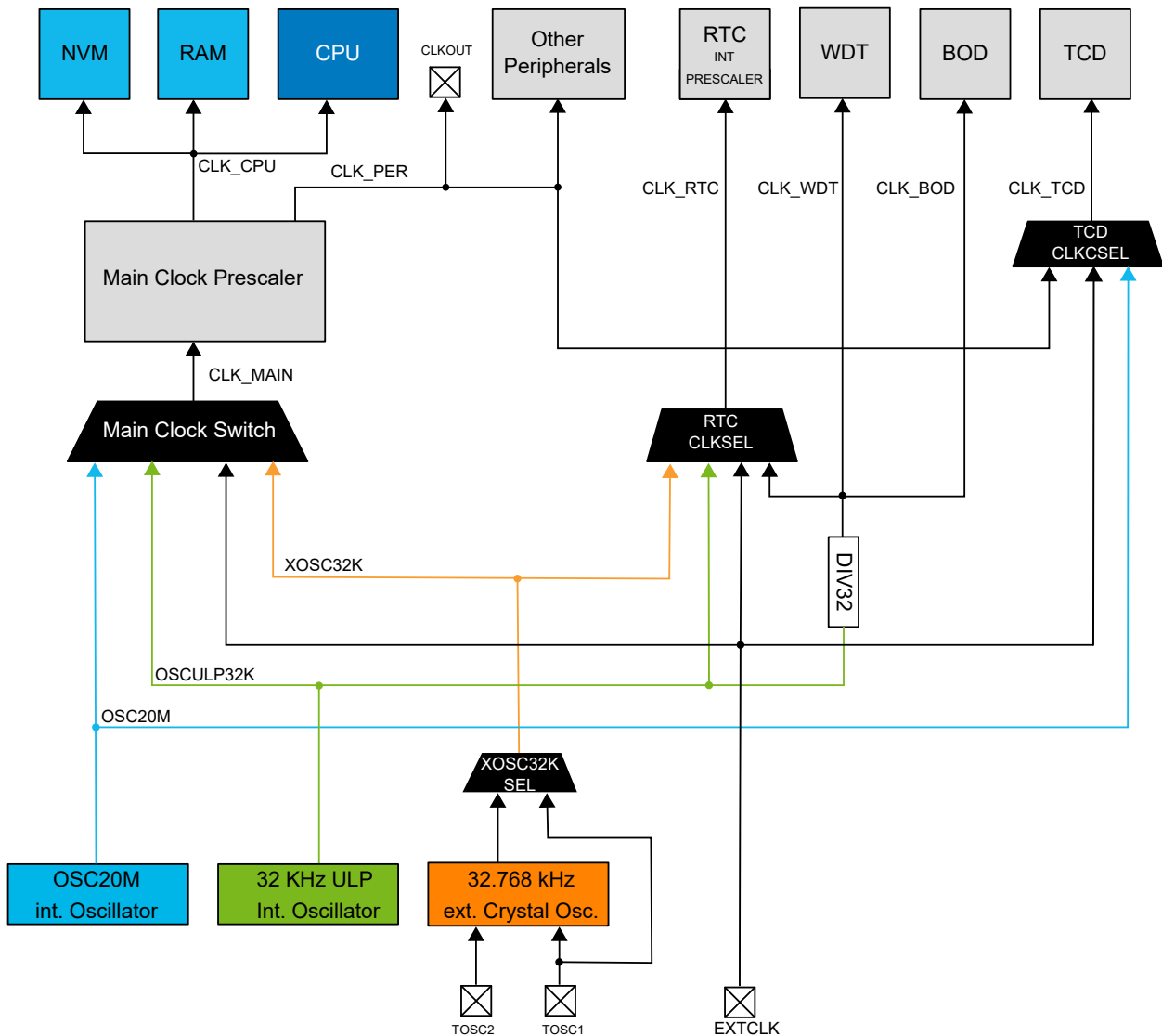
The Clock Controller peripheral (CLKCTRL) controls, distributes, and prescales the clock signals from the available oscillators. The CLKCTRL supports internal and external clock sources.

The CLKCTRL is based on an automatic clock request system, implemented in all peripherals on the device. The peripherals will automatically request the clocks needed. If multiple clock sources are available, the request is routed to the correct clock source.

The Main Clock (CLK\_MAIN) is used by the CPU, RAM, and the I/O bus. The main clock source can be selected and prescaled. Some peripherals can share the same clock source as the main clock, or run asynchronously to the main clock domain.

### 10.2.1 Block Diagram - CLKCTRL

Figure 10-1. CLKCTRL Block Diagram



The clock system consists of the main clock and other asynchronous clocks:

- **Main Clock**  
This clock is used by the CPU, RAM, Flash, the I/O bus, and all peripherals connected to the I/O bus. It is always running in Active and Idle Sleep mode and can be running in Standby Sleep mode if requested.

The main clock CLK\_MAIN is prescaled and distributed by the clock controller:

- CLK\_CPU is used by the CPU, SRAM, and the NVMCTRL peripheral to access the nonvolatile memory
- CLK\_PER is used by all peripherals that are not listed under asynchronous clocks.
- Clocks running asynchronously to the main clock domain:
  - CLK\_RTC is used by the RTC/PIT. It will be requested when the RTC/PIT is enabled. The clock source for CLK\_RTC should only be changed if the peripheral is disabled.
  - CLK\_WDT is used by the WDT. It will be requested when the WDT is enabled.

- CLK\_BOD is used by the BOD. It will be requested when the BOD is enabled in Sampled mode.

The clock source for the for the main clock domain is configured by writing to the Clock Select bits (CLKSEL) in the Main Clock Control A register (CLKCTRL.MCLKCTRLA). The asynchronous clock sources are configured by registers in the respective peripheral.

### 10.2.2 Signal Description

Signal	Type	Description
CLKOUT	Digital output	CLK_PER output

#### Related Links

[5. I/O Multiplexing and Considerations](#)

## 10.3 Functional Description

### 10.3.1 Sleep Mode Operation

When a clock source is not used/requested it will turn OFF. It is possible to request a clock source directly by writing a '1' to the Run Standby bit (RUNSTDBY) in the respective oscillator's Control A register (CLKCTRL.[osc]CTRLA). This will cause the oscillator to run constantly, except for Power-Down Sleep mode. Additionally, when this bit is written to '1' the oscillator start-up time is eliminated when the clock source is requested by a peripheral.

The main clock will always run in Active and Idle Sleep mode. In Standby Sleep mode, the main clock will only run if any peripheral is requesting it, or the Run in Standby bit (RUNSTDBY) in the respective oscillator's Control A register (CLKCTRL.[osc]CTRLA) is written to '1'.

In Power-Down Sleep mode, the main clock will stop after all NVM operations are completed.

### 10.3.2 Main Clock Selection and Prescaler

All internal oscillators can be used as the main clock source for CLK\_MAIN. The main clock source is selectable from software and can be safely changed during normal operation.

Built-in hardware protection prevents unsafe clock switching:

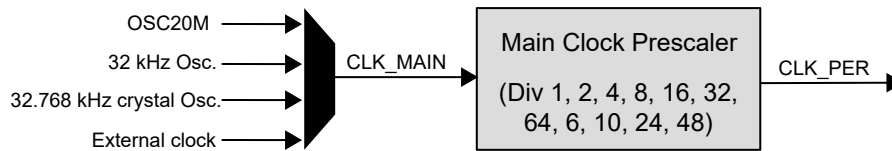
Upon selection of an external clock source, a switch to the chosen clock source will only occur if edges are detected, indicating it is stable. Until a sufficient number of clock edges are detected, the switch will not occur and it will not be possible to change to another clock source again without executing a Reset.

An ongoing clock source switch is indicated by the System Oscillator Changing flag (SOSC) in the Main Clock Status register (CLKCTRL.MCLKSTATUS). The stability of the external clock sources is indicated by the respective status flags (EXTS and XOSC32KS in CLKCTRL.MCLKSTATUS).

**⚠ CAUTION** If an external clock source fails while used as CLK\_MAIN source, only the WDT can provide a mechanism to switch back via System Reset.

CLK\_MAIN is fed into a prescaler before it is used by the peripherals (CLK\_PER) in the device. The prescaler divide CLK\_MAIN by a factor from 1 to 64.

**Figure 10-2. Main Clock and Prescaler**



The Main Clock and Prescaler configuration registers (CLKCTRL.MCLKCTRLA, CLKCTRL.MCLKCTRLB) are protected by the Configuration Change Protection Mechanism, employing a timed write procedure for changing these registers.

**Related Links**

[8.5.7 Configuration Change Protection \(CCP\)](#)

**10.3.3 Main Clock After Reset**

After any Reset, CLK\_MAIN is provided by the 16/20 MHz Oscillator (OSC20M) and with a prescaler division factor of 6. Since the actual frequency of the OSC20M is determined by the Frequency Select bits (FREQSEL) of the Oscillator Configuration fuse (FUSE.OSCCFG), these frequencies are possible after Reset:

**Table 10-1. Peripheral Clock Frequencies After Reset**

CLK_MAIN as Per FREQSEL in FUSE.OSCCFG	Resulting CLK_PER
16 MHz	2.66 MHz
20 MHz	3.3 MHz

See the OSC20M description for further details.

**Related Links**

[10.3.4.1.1 16/20 MHz Oscillator \(OSC20M\)](#)

**10.3.4 Clock Sources**

All internal clock sources are enabled automatically when they are requested by a peripheral. The crystal oscillator, based on an external crystal, must be enabled by writing a '1' to the ENABLE bit in the 32 KHz Crystal Oscillator Control A register (CLKCTRL.XOSC32CTRLA) before it can serve as a clock source.

The respective Oscillator Status bits in the Main Clock Status register (CLKCTRL.MCLKSTATUS) indicate whether the clock source is running and stable.

**Related Links**

[6.10 Configuration and User Fuses \(FUSE\)](#)

[8.5.7 Configuration Change Protection \(CCP\)](#)

**10.3.4.1 Internal Oscillators**

The internal oscillators do not require any external components to run. See the related links for accuracy and electrical characteristics.

**Related Links**

[37. Electrical Characteristics](#)



### 10.3.4.1.1 16/20 MHz Oscillator (OSC20M)

This oscillator can operate at multiple frequencies, selected by the value of the Frequency Select bits (FREQSEL) in the Oscillator Configuration Fuse (FUSE.OSCCFG). The center frequencies are:

- 16 MHz
- 20 MHz

After a system Reset, FUSE.OSCCFG determines the initial frequency of CLK\_MAIN.

During Reset, the calibration values for the OSC20M are loaded from fuses. There are two different calibration bit fields:

- The Calibration bit field (CAL20M) in the Calibration A register (CLKCTRL.OSC20MCALIBA) enables calibration around the current center frequency.
- The Oscillator Temperature Coefficient Calibration bit field (TEMPCAL20M) in the Calibration B register (CLKCTRL.OSC20MCALIBB) enables adjustment of the slope of the temperature drift compensation.

For applications requiring more fine-tuned frequency setting than the oscillator calibration provides, factory stored frequency error after calibrations are available.

The oscillator calibration can be locked by the Oscillator Lock (OSCLOCK) Fuse (FUSE.OSCCFG). When this fuse is '1', it is not possible to change the calibration. The calibration is locked if this oscillator is used as the main clock source and the Lock Enable bit (LOCKEN) in the Control B register (CLKCTRL.OSC20MCALIBB) is '1'.

The calibration bits are protected by the Configuration Change Protection Mechanism, requiring a timed write procedure for changing the main clock and prescaler settings.

The start-up time of this oscillator is the analog start-up time plus four oscillator cycles. Refer to the Electrical Characteristics section for the start-up time.

When changing the oscillator calibration value, the frequency may overshoot. If the oscillator is used as the main clock (CLK\_MAIN) it is recommended to change the main clock prescaler so that the main clock frequency does not exceed  $\frac{1}{4}$  of the maximum operation main clock frequency as described in the General Operating Ratings section. The system clock prescaler can be changed back after the oscillator calibration value has been updated.

#### Related Links

[6.10 Configuration and User Fuses \(FUSE\)](#)

[10.3.5 Configuration Change Protection](#)

[37.3 General Operating Ratings](#)

[10.3.3 Main Clock After Reset](#)

[37.9 Oscillators and Clocks](#)

#### **OSC20M Stored Frequency Error Compensation**

This oscillator can operate at multiple frequencies, selected by the value of the Frequency Select bits (FREQSEL) in the Oscillator Configuration fuse (FUSE.OSCCFG) at Reset. As previously mentioned appropriate calibration values are loaded to adjust to center frequency (OSC20M), and temperature drift compensation (TEMPCAL20M), meeting the specifications defined in the internal oscillator characteristics. For applications requiring wider operating range, the relative factory stored frequency error after calibrations can be used. The four errors are measured at different settings and are available in the signature row as signed byte values.

- SIGROW.OSC16ERR3V is the frequency error from 16 MHz measured at 3V

- SIGROW.OSC16ERR5V is the frequency error from 16 MHz measured at 5V
- SIGROW.OSC20ERR3V is the frequency error from 20 MHz measured at 3V
- SIGROW.OSC20ERR5V is the frequency error from 20 MHz measured at 5V

The error is stored as a compressed **Q1.10** fixed point 8-bit value, in order not to lose resolution, where the MSB is the sign bit and the seven LSBs the lower bits of the **Q1.10**.

$$BAUD_{actual} = \left( BAUD_{ideal} + \frac{BAUD_{ideal} * SigRowError}{1024} \right)$$

The minimum legal BAUD register value is 0x40, the target BAUD register value should therefore not be lower than 0x4A to ensure that the compensated BAUD value stays within the legal range, even for parts with negative compensation values. The example code below demonstrates how to apply this value for more accurate USART baud rate:

```
#include <assert.h>
/* Baud rate compensated with factory stored frequency error */
/* Asynchronous communication without Auto-baud (Sync Field) */
/* 16MHz Clock, 3V and 600 BAUD */

int8_t sigrow_val = SIGROW.OSC16ERR3V; // read signed error
int32_t baud_reg_val = 600; // ideal BAUD register value

assert (baud_reg_val >= 0x4A); // Verify legal min BAUD register
value with max_neg_comp
baud_reg_val *= (1024 + sigrow_val); // sum resolution + error
baud_reg_val /= 1024; // divide by resolution
USART0.BAUD = (int16_t) baud_reg_val; // set adjusted baud rate
```

### Related Links

[37.9 Oscillators and Clocks](#)

#### 10.3.4.1.2 32 KHz Oscillator (OSCULP32K)

The 32 KHz oscillator is optimized for Ultra Low-Power (ULP) operation. Power consumption is decreased at the cost of decreased accuracy compared to an external crystal oscillator.

This oscillator provides the 1 KHz signal for the Real-Time Counter (RTC), the Watchdog Timer (WDT), and the Brown-out Detector (BOD).

The start-up time of this oscillator is the oscillator start-up time plus four oscillator cycles. Refer to the Electrical Characteristics chapter for the start-up time.

### Related Links

[17. BOD - Brown-out Detector](#)

[19. WDT - Watchdog Timer](#)

[23. RTC - Real-Time Counter](#)

#### 10.3.4.2 External Clock Sources

These external clock sources are available:

- External Clock from pin EXTCLK
- The TOSC1 and TOSC2 pins are dedicated to driving a 32.768 kHz Crystal Oscillator (XOSC32K).
- Instead of a crystal oscillator, TOSC1 can be configured to accept an external clock source.

##### 10.3.4.2.1 32.768 kHz Crystal Oscillator (XOSC32K)

This oscillator supports two input options: Either a crystal is connected to the pins TOSC1 and TOSC2, or an external clock running at 32 KHz is connected to TOSC1. The input option must be configured by writing the Source Select bit (SEL) in the XOSC32K Control A register (CLKCTRL.XOSC32KCTRLA).

The XOSC32K is enabled by writing a '1' to its ENABLE bit in CLKCTRL.XOSC32KCTRLA. When enabled, the configuration of the GPIO pins used by the XOSC32K is overridden as TOSC1, TOSC2 pins. The Enable bit needs to be set for the oscillator to start running when requested.

The start-up time of a given crystal oscillator can be accommodated by writing to the Crystal Start-up Time bits (CSUT) in CLKCTRL.XOSC32KCTRLA.

When XOSC32K is configured to use an external clock on TOSC1, the start-up time is fixed to two cycles.

### 10.3.4.2.2 External Clock (EXTCLK)

The EXTCLK is taken directly from the pin. This GPIO pin is automatically configured for EXTCLK if any peripheral is requesting this clock.

This clock source has a start-up time of two cycles when first requested.

### 10.3.5 Configuration Change Protection

This peripheral has registers that are under Configuration Change Protection (CCP). In order to write to these, a certain key must be written to the CPU.CCP register first, followed by a write access to the protected bits within four CPU instructions.

Attempting to write to a protected register without following the appropriate CCP unlock sequence leaves the protected register unchanged.

The following registers are under CCP:

**Table 10-2. CLKCTRL - Registers Under Configuration Change Protection**

Register	Key
CLKCTRL.MCLKCTRLB	IOREG
CLKCTRL.MCLKLOCK	IOREG
CLKCTRL.XOSC32KCTRLA	IOREG
CLKCTRL.MCLKCTRLA	IOREG
CLKCTRL.OSC20MCTRLA	IOREG
CLKCTRL.OSC20MCALIBA	IOREG
CLKCTRL.OSC20MCALIBB	IOREG
CLKCTRL.OSC32KCTRLA	IOREG

#### Related Links

[8.5.7.1 Sequence for Write Operation to Configuration Change Protected I/O Registers](#)

### 10.4 Register Summary - CLKCTRL

Offset	Name	Bit Pos.								
0x00	<a href="#">MCLKCTRLA</a>	7:0	CLKOUT							CLKSEL[1:0]
0x01	<a href="#">MCLKCTRLB</a>	7:0						PDIV[3:0]		PEN
0x02	<a href="#">MCLKLOCK</a>	7:0								LOCKEN
0x03	<a href="#">MCLKSTATUS</a>	7:0	EXTS	XOSC32KS	OSC32KS	OSC20MS				SOSC
0x04 ... 0x0F	Reserved									
0x10	<a href="#">OSC20MCTRLA</a>	7:0							RUNSTDBY	
0x11	<a href="#">OSC20MCALIBA</a>	7:0						CAL20M[5:0]		
0x12	<a href="#">OSC20MCALIBB</a>	7:0	LOCK					TEMPCAL20M[3:0]		
0x13 ... 0x17	Reserved									
0x18	<a href="#">OSC32KCTRLA</a>	7:0							RUNSTDBY	
0x19 ... 0x1B	Reserved									
0x1C	<a href="#">XOSC32KCTRLA</a>	7:0				CSUT[1:0]		SEL	RUNSTDBY	ENABLE

### 10.5 Register Description

### 10.5.1 Main Clock Control A

**Name:** MCLKCTRLA  
**Offset:** 0x00  
**Reset:** 0x00  
**Property:** Configuration Change Protection

Bit	7	6	5	4	3	2	1	0
	CLKOUT						CLKSEL[1:0]	
Access	R/W						R/W	R/W
Reset	0						0	0

**Bit 7 – CLKOUT** System Clock Out

When this bit is written to '1', the system clock is output to CLKOUT pin.

When the device is in a Sleep mode, there is no clock output unless a peripheral is using the system clock.

**Bits 1:0 – CLKSEL[1:0]** Clock Select

This bit field selects the source for the Main Clock (CLK\_MAIN).

Value	Name	Description
0x0	OSC20M	16/20 MHz internal oscillator
0x1	OSCULP32K	32 KHz internal ultra low-power oscillator
0x2	XOSC32K	32.768 kHz external crystal oscillator
0x3	EXTCLK	External clock

### 10.5.2 Main Clock Control B

**Name:** MCLKCTRLB  
**Offset:** 0x01  
**Reset:** 0x11  
**Property:** Configuration Change Protection

	Bit	7	6	5	4	3	2	1	0
					PDIV[3:0]				PEN
Access					R/W	R/W	R/W	R/W	R/W
Reset					1	0	0	0	1

#### Bits 4:1 – PDIV[3:0] Prescaler Division

If the Prescaler Enable (PEN) bit is written to '1', these bits define the division ratio of the main clock prescaler.

These bits can be written during run-time to vary the clock frequency of the system to suit the application requirements.

The user software must ensure a correct configuration of input frequency (CLK\_MAIN) and prescaler settings, such that the resulting frequency of CLK\_PER never exceeds the allowed maximum (see Electrical Characteristics).

Value	Description
Value	Division
0x0	2
0x1	4
0x2	8
0x3	16
0x4	32
0x5	64
0x8	6
0x9	10
0xA	12
0xB	24
0xC	48
other	Reserved

#### Bit 0 – PEN Prescaler Enable

This bit must be written '1' to enable the prescaler. When enabled, the division ratio is selected by the PDIV bit field.

When this bit is written to '0', the main clock will pass through undivided (CLK\_PER=CLK\_MAIN), regardless of the value of PDIV.

**10.5.3 Main Clock Lock**

**Name:** MCLKLOCK  
**Offset:** 0x02  
**Reset:** Based on OSCLOCK in FUSE.OSCCFG  
**Property:** Configuration Change Protection

	7	6	5	4	3	2	1	0
								LOCKEN
Access								R/W
Reset								x

**Bit 0 – LOCKEN** Lock Enable

Writing this bit to '1' will lock the CLKCTRL.MCLKCTRLA and CLKCTRL.MCLKCTRLB registers, and, if applicable, the calibration settings for the current main clock source from further software updates. Once locked, the CLKCTRL.MCLKLOCK registers cannot be accessed until the next hardware Reset.

This provides protection for the CLKCTRL.MCLKCTRLA and CLKCTRL.MCLKCTRLB registers and calibration settings for the main clock source from unintentional modification by software.

At Reset, the LOCKEN bit is loaded based on the OSCLOCK bit in FUSE.OSCCFG.

**Related Links**

[6.10 Configuration and User Fuses \(FUSE\)](#)

### 10.5.4 Main Clock Status

**Name:** MCLKSTATUS  
**Offset:** 0x03  
**Reset:** 0x00  
**Property:** -

Bit	7	6	5	4	3	2	1	0
	EXTS	XOSC32KS	OSC32KS	OSC20MS				SOSC
Access	R	R	R	R				R
Reset	0	0	0	0				0

#### Bit 7 – EXTS External Clock Status

Value	Description
0	EXTCLK has not started
1	EXTCLK has started

#### Bit 6 – XOSC32KS XOSC32K Status

The Status bit will only be available if the source is requested as the main clock or by another module. If the oscillator RUNSTDBY bit is set but the oscillator is unused/not requested, this bit will be 0.

Value	Description
0	XOSC32K is not stable
1	XOSC32K is stable

#### Bit 5 – OSC32KS OSCULP32K Status

The Status bit will only be available if the source is requested as the main clock or by another module. If the oscillator RUNSTDBY bit is set but the oscillator is unused/not requested, this bit will be 0.

Value	Description
0	OSCULP32K is not stable
1	OSCULP32K is stable

#### Bit 4 – OSC20MS OSC20M Status

The Status bit will only be available if the source is requested as the main clock or by another module. If the oscillator RUNSTDBY bit is set but the oscillator is unused/not requested, this bit will be 0.

Value	Description
0	OSC20M is not stable
1	OSC20M is stable

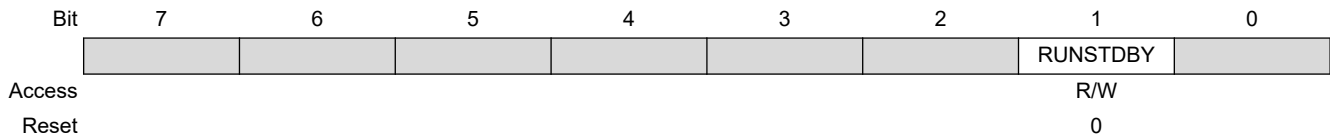
#### Bit 0 – SOSC Main Clock Oscillator Changing

Value	Description
0	The clock source for CLK_MAIN is not undergoing a switch
1	The clock source for CLK_MAIN is undergoing a switch and will change as soon as the new source is stable



**10.5.5 16/20 MHz Oscillator Control A**

**Name:** OSC20MCTRLA  
**Offset:** 0x10  
**Reset:** 0x00  
**Property:** Configuration Change Protection



**Bit 1 – RUNSTDBY** Run Standby

This bit forces the oscillator ON in all modes, even when unused by the system. In Standby Sleep mode this can be used to ensure immediate wake-up and not waiting for oscillator start-up time.

When not requested by peripherals, no oscillator output is provided.

It takes four oscillator cycles to open the clock gate after a request but the oscillator analog start-up time will be removed when this bit is set.

**10.5.6 16/20 MHz Oscillator Calibration A**

**Name:** OSC20MCALIBA  
**Offset:** 0x11  
**Reset:** Based on FREQSEL in FUSE.OSCCFG  
**Property:** Configuration Change Protection

Bit	7	6	5	4	3	2	1	0
			CAL20M[5:0]					
Access			R/W	R/W	R/W	R/W	R/W	R/W
Reset			x	x	x	x	x	x

**Bits 5:0 – CAL20M[5:0] Calibration**

These bits change the frequency around the current center frequency of the OSC20M for fine-tuning.

At Reset, the factory calibrated values are loaded based on the FREQSEL bits in FUSE.OSCCFG.

**10.5.7 16/20 MHz Oscillator Calibration B**

**Name:** OSC20MCALIBB  
**Offset:** 0x12  
**Reset:** Based on FUSE.OSCCFG  
**Property:** Configuration Change Protection

Bit	7	6	5	4	3	2	1	0
	LOCK				TEMPCAL20M[3:0]			
Access	R				R/W	R/W	R/W	R/W
Reset	x				x	x	x	x

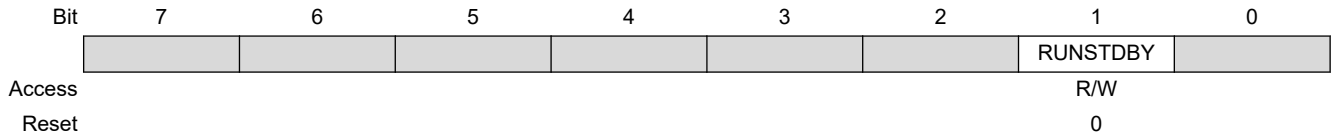
**Bit 7 – LOCK** Oscillator Calibration Locked by Fuse  
 When this bit is set, the calibration settings in CLKCTRL.OSC20MCALIBA and CLKCTRL.OSC20MCALIBB cannot be changed.  
 The reset value is loaded from the OSCLOCK bit in the Oscillator Configuration Fuse (FUSE.OSCCFG).

**Bits 3:0 – TEMPCAL20M[3:0]** Oscillator Temperature Coefficient Calibration  
 These bits tune the slope of the temperature compensation.

At Reset, the factory calibrated values are loaded based on the FREQSEL bits in FUSE.OSCCFG.

**10.5.8 32 KHz Oscillator Control A**

**Name:** OSC32KCTRLA  
**Offset:** 0x18  
**Reset:** 0x00  
**Property:** Configuration Change Protection



**Bit 1 – RUNSTDBY** Run Standby

This bit forces the oscillator ON in all modes, even when unused by the system. In Standby Sleep mode this can be used to ensure immediate wake-up and not waiting for the oscillator start-up time.

When not requested by peripherals, no oscillator output is provided.

It takes four oscillator cycles to open the clock gate after a request but the oscillator analog start-up time will be removed when this bit is set.

### 10.5.9 32.768 kHz Crystal Oscillator Control A

**Name:** XOSC32KCTRLA  
**Offset:** 0x1C  
**Reset:** 0x00  
**Property:** Configuration Change Protection

The SEL and CSUT bits cannot be changed as long as the ENABLE bit is set or the XOSC32K Stable bit (XOSC32KS) in CLKCTRL.MCLKSTATUS is high.

To change settings in a safe way: write a '0' to the ENABLE bit and wait until XOSC32KS is '0' before re-enabling the XOSC32K with new settings.

	Bit	7	6	5	4	3	2	1	0
				CSUT[1:0]			SEL	RUNSTDBY	ENABLE
Access				R/W	R/W		R/W	R/W	R/W
Reset				0	0		0	0	0

#### Bits 5:4 – CSUT[1:0] Crystal Start-Up Time

These bits select the start-up time for the XOSC32K. It is write protected when the oscillator is enabled (ENABLE=1).

If SEL=1, the start-up time will not be applied.

Value	Name	Description
0x0	1K	1k cycles
0x1	16K	16k cycles
0x2	32K	32k cycles
0x3	64K	64k cycles

#### Bit 2 – SEL Source Select

This bit selects the external source type. It is write protected when the oscillator is enabled (ENABLE=1).

Value	Description
0	External crystal
1	External clock on TOSC1 pin

#### Bit 1 – RUNSTDBY Run Standby

Writing this bit to '1' starts the crystal oscillator and forces the oscillator ON in all modes, even when unused by the system if the ENABLE bit is set. In Standby Sleep mode this can be used to ensure immediate wake-up and not waiting for oscillator start-up time. When this bit is '0', the crystal oscillator is only running when requested and the ENABLE bit is set.

The output of XOSC32K is not sent to other peripherals unless it is requested by one or more peripherals.

When the RUNSTDBY bit is set there will only be a delay of two to three crystal oscillator cycles after a request until the oscillator output is received, if the initial crystal start-up time has already completed.

According to RUNSTBY bit, the oscillator will be turned ON all the time if the device is in Active, Idle, or Standby Sleep mode, or only be enabled when requested.

This bit is I/O protected to prevent unintentional enabling of the oscillator.

**Bit 0 – ENABLE** Enable

When this bit is written to '1', the configuration of the respective input pins is overridden to TOSC1 and TOSC2. Also, the Source Select bit (SEL) and Crystal Start-Up Time (CSUT) become read-only.

This bit is I/O protected to prevent unintentional enabling of the oscillator.

## 11. SLPCTRL - Sleep Controller

### 11.1 Features

- Power management for adjusting power consumption and functions
- Three sleep modes:
  - Idle
  - Standby
  - Power-Down
- Configurable Standby Sleep mode where peripherals can be configured as ON or OFF.

### 11.2 Overview

Sleep modes are used to shut down peripherals and clock domains in the device in order to save power. The Sleep Controller (SLPCTRL) controls and handles the transitions between active and sleep mode.

There are in total four modes available:

- One active mode in which the software is executed
- Three sleep modes:
  - Idle
  - Standby
  - Power-Down

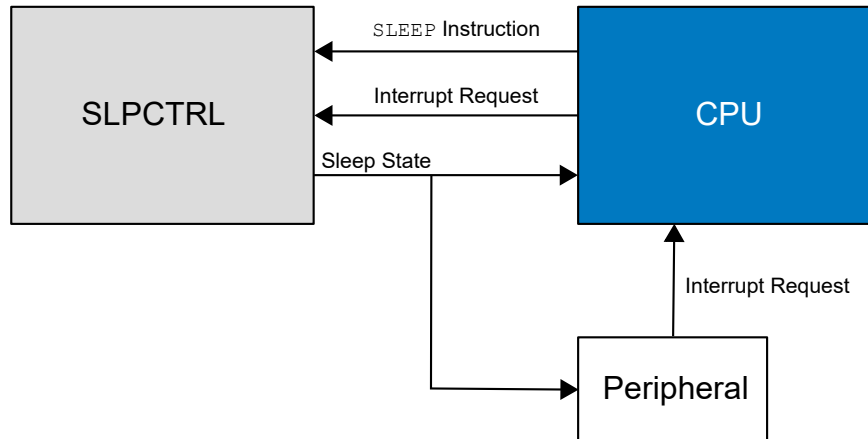
All sleep modes are available and can be entered from active mode. In active mode, the CPU is executing application code. When the device enters sleep mode, program execution is stopped and interrupts or a reset is used to wake the device again. The application code decides which sleep mode to enter and when.

Interrupts are used to wake the device from sleep. The available interrupt wake-up sources depend on the configured sleep mode. When an interrupt occurs, the device will wake up and execute the interrupt service routine before continuing normal program execution from the first instruction after the `SLEEP` instruction. Any Reset will take the device out of a sleep mode.

The content of the register file, SRAM and registers are kept during sleep. If a Reset occurs during sleep, the device will reset, start, and execute from the Reset vector.

### 11.2.1 Block Diagram

Figure 11-1. Sleep Controller in System



### 11.2.2 System Dependencies

In order to use this peripheral, other parts of the system must be configured correctly, as described below.

Table 11-1. SLPCTRL System Dependencies

Dependency	Applicable	Peripheral
Clocks	Yes	CLKCTRL
I/O Lines and Connections	No	-
Interrupts	No	-
Events	No	-
Debug	Yes	UPDI

#### 11.2.2.1 Clocks

This peripheral depends on the peripheral clock.

#### Related Links

[10. CLKCTRL - Clock Controller](#)

#### 11.2.2.2 I/O Lines and Connections

Not applicable.

#### 11.2.2.3 Interrupts

Not applicable.

#### 11.2.2.4 Events

Not applicable.

#### 11.2.2.5 Debug Operation

When run-time debugging, this peripheral will continue normal operation. The SLPCTRL is only affected by a break in debug operation: If the SLPCTRL is in a sleep mode when a break occurs, the device will wake up and the SLPCTRL will go to Active mode, even if there are no pending interrupt requests.

If the peripheral is configured to require periodical service by the CPU through interrupts or similar, improper operation or data loss may result during halted debugging.



## 11.3 Functional Description

### 11.3.1 Initialization

To put the device into a sleep mode, follow these steps:

- Configure and enable the interrupts that shall be able to wake the device from sleep. Also, enable global interrupts.



If there are no interrupts enabled when going to sleep, the device cannot wake up again. Only a Reset will allow the device to continue operation.

- Select the sleep mode to be entered and enable the Sleep Controller by writing to the Sleep Mode bits (SMODE) and the Enable bit (SEN) in the Control A register (SLPCTRL.CTRLA). A `SLEEP` instruction must be run to make the device actually go to sleep.

### 11.3.2 Operation

#### 11.3.2.1 Sleep Modes

In addition to Active mode, there are three different sleep modes, with decreasing power consumption and functionality.

**Idle**      The CPU stops executing code, no peripherals are disabled.  
All interrupt sources can wake-up the device.

**Standby**    The user can configure peripherals to be enabled or not, using the respective RUNSTBY bit. This means that the power consumption is highly dependent on what functionality is enabled, and thus may vary between the Idle and Power-Down levels.  
SleepWalking is available for the ADC module.

The wake-up sources are pin interrupts, TWI address match, UART Start-of-Frame interrupt (if USART is enabled to run in Standby), ADC window interrupt (if PTC enabled to run in Standby), RTC interrupt (if RTC enabled to run in Standby), and TCB interrupt.

**Power-Down**    Only the WDT and the PIT (a component of the RTC) are active.

The only wake-up sources are the pin change interrupt and TWI address match.

**Table 11-2. Sleep Mode Activity Overview**

Group	Peripheral		Active in Sleep Mode		
		Clock	Idle	Standby	Power-Down
Active Clock Domain	CPU	CLK_CPU			
	Peripherals	CLK_PER	X		
	RTC	CLK_RTC	X	X*	
	ADC/PTC	CLK_PER	X	X*	
	PIT (RTC)	CLK_RTC	X	X	X
	WDT	CLK_WDT	X	X	X
Oscillators	Main Clock Source		X	X*	
	RTC Clock Source		X	X*	

Group	Peripheral		Active in Sleep Mode		
		Clock	Idle	Standby	Power-Down
	WDT Oscillator		X	X	X
Wake-Up Sources	INTn and Pin Change		X	X	X
	TWI Address Match		X	X	X
	Periodic Interrupt Timer		X	X	X
	UART Start-of-Frame		X	X*	
	ADC/PTC Window		X	X*	
	RTC Interrupt		X	X*	
	All other Interrupts		X		

**Note:**

- X means active. X\* indicates that the RUNSTBY bit of the corresponding peripheral must be set to enter the active state.

### 11.3.2.2 Wake-Up Time

The normal wake-up time for the device is six main clock cycles (CLK\_PER), plus the time it takes to start up the main clock source:

- In Idle Sleep mode, the main clock source is kept running so it will not be any extra wake-up time.
- In Standby Sleep mode, the main clock might be running so it depends on the peripheral configuration.
- In Power-Down Sleep mode, only the ULP 32 KHz oscillator and RTC clock may be running if it is used by the BOD or WDT. All other clock sources will be OFF.

**Table 11-3. Sleep Modes and Start-Up Time**

Sleep Mode	Start-Up Time
IDLE	6 CLK
Standby	6 CLK + OSC start-up
Power-Down	6 CLK + OSC start-up

The start-up time for the different clock sources is described in the Clock Controller (CLKCTRL) section.

In addition to the normal wake-up time, it is possible to make the device wait until the BOD is ready before executing code. This is done by writing 0x3 to the BOD Operation mode in Active and Idle bits (ACTIVE) in the BOD Configuration fuse (FUSE.BODCFG). If the BOD is ready before the normal wake-up time, the total wake-up time will be the same. If the BOD takes longer than the normal wake-up time, the wake-up time will be extended until the BOD is ready. This ensures correct supply voltage whenever code is executed.

### 11.3.3 Configuration Change Protection

Not applicable.

## 11.4 Register Summary - SLPCTRL

Offset	Name	Bit Pos.							
0x00	<a href="#">CTRLA</a>	7:0						SMODE[1:0]	SEN

## 11.5 Register Description

### 11.5.1 Control A

**Name:** CTRLA  
**Offset:** 0x00  
**Reset:** 0x00  
**Property:** -

Bit	7	6	5	4	3	2	1	0
						SMODE[1:0]		SEN
Access	R	R	R	R	R	R/W	R/W	R/W
Reset	0	0	0	0	0	0	0	0

#### Bits 2:1 – SMODE[1:0] Sleep Mode

Writing these bits selects the sleep mode entered when the Sleep Enable bit (SEN) is written to '1' and the `SLEEP` instruction is executed.

Value	Name	Description
0x0	IDLE	Idle Sleep mode enabled
0x1	STANDBY	Standby Sleep mode enabled
0x2	PDOWN	Power-Down Sleep mode enabled
other	-	Reserved

#### Bit 0 – SEN Sleep Enable

This bit must be written to '1' before the `SLEEP` instruction is executed to make the MCU enter the selected sleep mode.

## 12. RSTCTRL - Reset Controller

### 12.1 Features

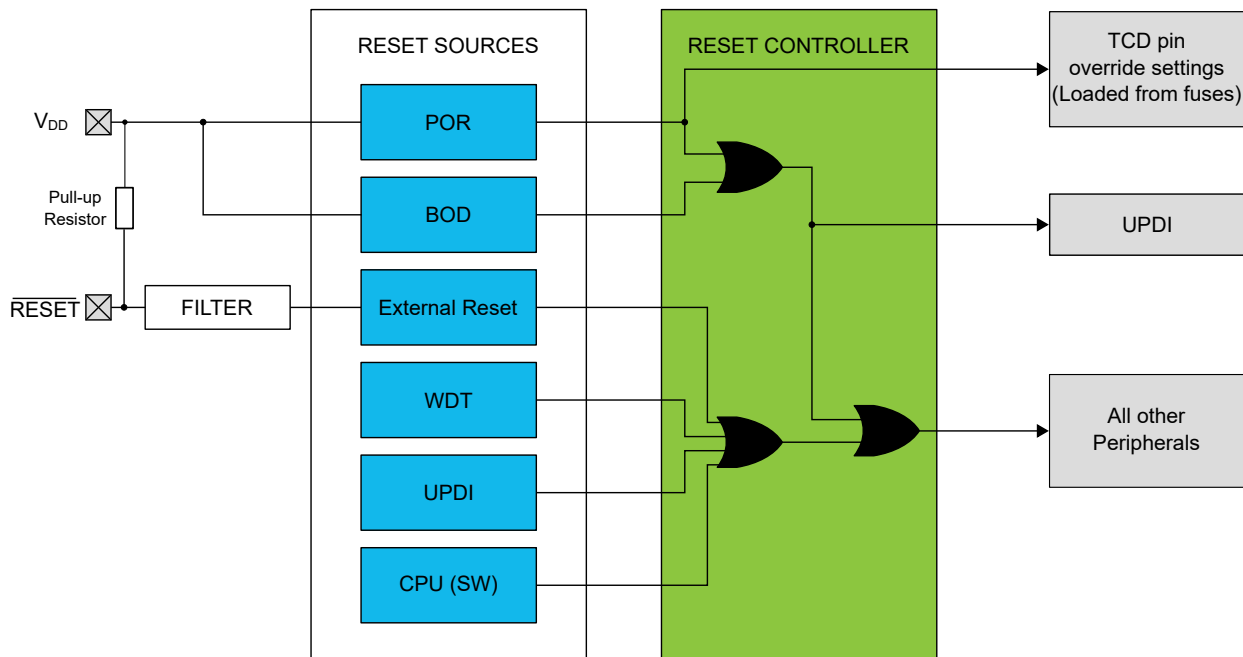
- Reset the device and set it to an initial state
- Reset Flag register for identifying the Reset source in the software
- Multiple Reset sources:
  - Power supply Reset sources: Brown-out Detect (BOD), Power-on Reset (POR)
  - User Reset sources: External Reset pin ( $\overline{\text{RESET}}$ ), Watchdog Reset (WDT), Software Reset (SW), and UPDI Reset

### 12.2 Overview

The Reset Controller (RSTCTRL) manages the Reset of the device. It issues a device Reset, sets the device to its initial state, and allows the Reset source to be identified by the software.

#### 12.2.1 Block Diagram

**Figure 12-1. Reset System Overview**



#### 12.2.2 Signal Description

Signal	Description	Type
$\overline{\text{RESET}}$	External Reset (active-low)	Digital input

## 12.3 Functional Description

### 12.3.1 Initialization

The Reset Controller (RSTCTRL) is always enabled, but some of the Reset sources must be enabled (either by fuses or by software) before they can request a Reset.

After any Reset, the Reset source that caused the Reset is found in the Reset Flag register (RSTCTRL.RSTFR).

After a Power-on Reset, only the POR flag will be set.

The flags are kept until they are cleared by writing a '1' to them.

After Reset from any source, all registers that are loaded from fuses are reloaded.

### 12.3.2 Operation

#### 12.3.2.1 Reset Sources

There are two kinds of sources for Resets:

- Power supply Resets, which are caused by changes in the power supply voltage: Power-on Reset (POR) and Brown-out Detector (BOD).
- User Resets, which are issued by the application, by the debug operation, or by pin changes (Software Reset, Watchdog Reset, UPDI Reset, and external Reset pin  $\overline{\text{RESET}}$ ).

##### 12.3.2.1.1 Power-On Reset (POR)

A Power-on Reset (POR) is generated by an on-chip detection circuit. The POR is activated when the  $V_{DD}$  rises until it reaches the POR threshold voltage. The POR is always enabled and will also detect when the  $V_{DD}$  falls below the threshold voltage.

All volatile logic is reset on POR. All fuses are reloaded after the Reset is released.

##### 12.3.2.1.2 Brown-Out Detector (BOD) Reset Source

The on-chip Brown-out Detection circuit will monitor the  $V_{DD}$  level during operation by comparing it to a fixed trigger level. The trigger level for the BOD can be selected by fuses. If BOD is unused in the application it is forced to a minimum level in order to ensure a safe operation during internal Reset and chip erase.

All logic is reset on BOD Reset, except the BOD configuration. All fuses are reloaded after the Reset is released.

#### Related Links

[17. BOD - Brown-out Detector](#)

##### 12.3.2.1.3 Software Reset

The software Reset makes it possible to issue a system Reset from software. The Reset is generated by writing a '1' to the Software Reset Enable bit (SWRE) in the Software Reset register (RSTCTRL.SWRR).

The Reset will take place immediately after the bit is written and the device will be kept in reset until the Reset sequence is completed. All logic is reset on software Reset, except UPDI and BOD configuration. All fuses are reloaded after the Reset is released.

##### 12.3.2.1.4 External Reset

The external Reset is enabled by fuse (see fuse map).

When enabled, the external Reset requests a Reset as long as the  $\overline{\text{RESET}}$  pin is low. The device will stay in Reset until  $\overline{\text{RESET}}$  is high again. All logic is reset on external reset, except UPDI and BOD configuration. All fuses are reloaded after the Reset is released.

### Related Links

[6.10 Configuration and User Fuses \(FUSE\)](#)

#### 12.3.2.1.5 Watchdog Reset

The Watchdog Timer (WDT) is a system function for monitoring correct program operation. If the WDT is not reset from software according to the programmed time-out period, a Watchdog Reset will be issued. See the WDT documentation for further details.

All logic is reset on WDT Reset, except UPDI and BOD configuration. All fuses are reloaded after the Reset is released.

### Related Links

[19. WDT - Watchdog Timer](#)

#### 12.3.2.1.6 Universal Program Debug Interface (UPDI) Reset

The UPDI contains a separate Reset source that is used to reset the device during external programming and debugging. The Reset source is accessible only from external debuggers and programmers. All logic is reset on UPDI Reset, except the UPDI itself and BOD configuration. All fuses are reloaded after the Reset is released. See UPDI chapter on how to generate a UPDI Reset request.

### Related Links

[33. UPDI - Unified Program and Debug Interface](#)

#### 12.3.2.2 Reset Time

The Reset time can be split in two.

The first part is when any of the Reset sources are active. This part depends on the input to the Reset sources. The external Reset is active as long as the  $\overline{\text{RESET}}$  pin is low, the Power-on Reset (POR) and Brown-out Detector (BOD) is active as long as the supply voltage is below the Reset source threshold.

When all the Reset sources are released, an internal Reset initialization of the device is done. This time will be increased with the start-up time given by the start-up time fuse setting (SUT in FUSE.SYSCFG1). The internal Reset initialization time will also increase if the CRCSCAN is configured to run at start-up (CRCSRC in FUSE.SYSCFG0).

#### 12.3.3 Sleep Mode Operation

The Reset Controller continues to operate in all active and sleep modes.

#### 12.3.4 Configuration Change Protection

This peripheral has registers that are under Configuration Change Protection (CCP). In order to write to these, a certain key must be written to the CPU.CCP register first, followed by a write access to the protected bits within four CPU instructions.

Attempting to write to a protected register without following the appropriate CCP unlock sequence leaves the protected register unchanged.

The following registers are under CCP:

---

---

**Table 12-1. RSTCTRL - Registers Under Configuration Change Protection**

Register	Key
RSTCTRL.SWRR	IOREG

**Related Links**

[8.5.7.1 Sequence for Write Operation to Configuration Change Protected I/O Registers](#)



**12.4 Register Summary - RSTCTRL**

Offset	Name	Bit Pos.								
0x00	<a href="#">RSTFR</a>	7:0			UPDIRF	SWRF	WDRF	EXTRF	BORF	PORF
0x01	<a href="#">SWRR</a>	7:0								SWRE

**12.5 Register Description**

### 12.5.1 Reset Flag Register

**Name:** RSTFR  
**Offset:** 0x00  
**Reset:** 0xXX  
**Property:** -

All flags are cleared by writing a '1' to them. They are also cleared by a Power-on Reset, with the exception of the Power-On Reset Flag (PORF).

	7	6	5	4	3	2	1	0
Bit			UPDIRF	SWRF	WDRF	EXTRF	BORF	PORF
Access	R	R	R/W	R/W	R/W	R/W	R/W	R/W
Reset	0	0	x	x	x	x	x	x

**Bit 5 – UPDIRF** UPDI Reset Flag

This bit is set if a UPDI Reset occurs.

**Bit 4 – SWRF** Software Reset Flag

This bit is set if a Software Reset occurs.

**Bit 3 – WDRF** Watchdog Reset Flag

This bit is set if a Watchdog Reset occurs.

**Bit 2 – EXTRF** External Reset Flag

This bit is set if an External Reset occurs.

**Bit 1 – BORF** Brown-Out Reset Flag

This bit is set if a Brown-out Reset occurs.

**Bit 0 – PORF** Power-On Reset Flag

This bit is set if a Power-on Reset occurs.

This flag is only cleared by writing a '1' to it.

After a POR, only the POR flag is set and all other flags are cleared. No other flags can be set before a full system boot is run after the POR.

**12.5.2 Software Reset Register**

**Name:** SWRR  
**Offset:** 0x01  
**Reset:** 0x00  
**Property:** Configuration Change Protection

Bit	7	6	5	4	3	2	1	0
								SWRE
Access	R	R	R	R	R	R	R	R/W
Reset	0	0	0	0	0	0	0	0

**Bit 0 – SWRE** Software Reset Enable  
When this bit is written to '1', a software Reset will occur.  
This bit will always read as '0'.

## 13. CPUINT - CPU Interrupt Controller

### 13.1 Features

- Short and Predictable Interrupt Response Time
- Separate Interrupt Configuration and Vector Address for Each Interrupt
- Interrupt Prioritizing by Level and Vector Address
- Non-Maskable Interrupts (NMI) for Critical Functions
- Two Interrupt Priority Levels: 0 (normal) and 1 (high)
  - One of the interrupt requests can optionally be assigned as a priority level 1 interrupt
  - Optional round robin priority scheme for priority level 0 interrupts
- Interrupt Vectors Optionally Placed in the Application Section or the Boot Loader Section
- Selectable Compact Vector Table

### 13.2 Overview

An interrupt request signals a change of state inside a peripheral and can be used to alter program execution. Peripherals can have one or more interrupts, and all are individually enabled and configured.

When an interrupt is enabled and configured, it will generate an interrupt request when the interrupt condition occurs.

The CPU Interrupt Controller (CPUINT) handles and prioritizes interrupt requests. When an interrupt is enabled and the interrupt condition occurs, the CPUINT will receive the interrupt request. Based on the interrupt's priority level and the priority level of any ongoing interrupts, the interrupt request is either acknowledged or kept pending until it has priority. When an interrupt request is acknowledged by the CPUINT, the Program Counter is set to point to the interrupt vector. The interrupt vector is normally a jump to the interrupt handler (i.e., the software routine that handles the interrupt). After returning from the interrupt handler, program execution continues from where it was before the interrupt occurred. One instruction is always executed before any pending interrupt is served.

The CPUINT Status register (CPUINT.STATUS) contains state information that ensures that the CPUINT returns to the correct interrupt level when the `RETI` (interrupt return) instruction is executed at the end of an interrupt handler. Returning from an interrupt will return the CPUINT to the state it had before entering the interrupt. CPUINT.STATUS is not saved automatically upon an interrupt request.

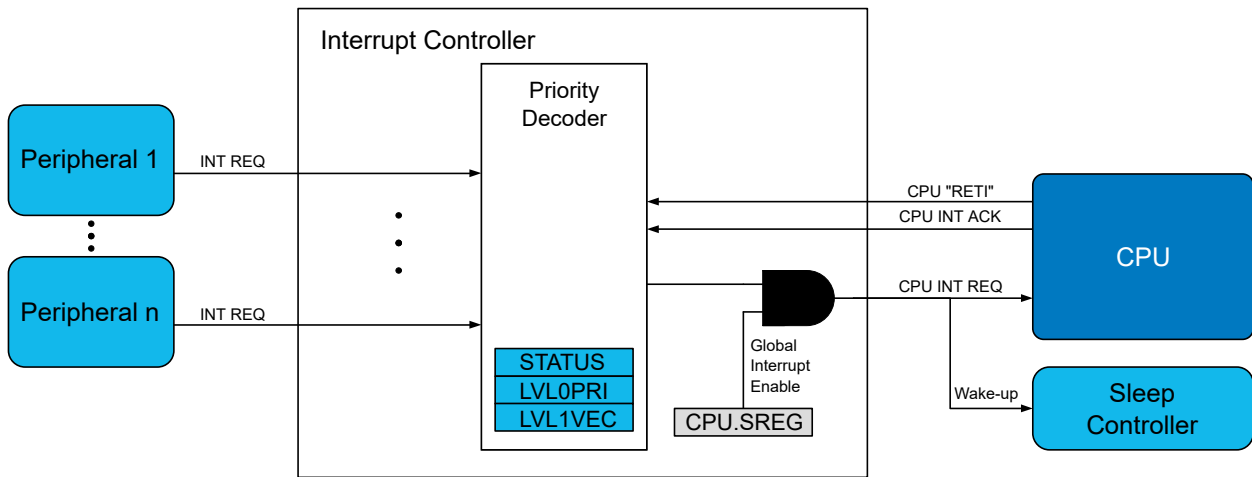
By default, all peripherals are priority level 0. It is possible to set one single interrupt vector to the higher priority level 1. Interrupts are prioritized according to their priority level and their interrupt vector address. Priority level 1 interrupts will interrupt level 0 interrupt handlers. Among priority level 0 interrupts, the priority is determined from the interrupt vector address, where the lowest interrupt vector address has the highest interrupt priority.

Optionally, a round robin scheduling scheme can be enabled for priority level 0 interrupts. This ensures that all interrupts are serviced within a certain amount of time.

Interrupt generation must be globally enabled by writing a '1' to the Global Interrupt Enable bit (I) in the CPU Status register (CPU.SREG). This bit is not cleared when an interrupt is acknowledged.

### 13.2.1 Block Diagram

Figure 13-1. CPUINT Block Diagram



### 13.2.2 Signal Description

Not applicable.

### 13.2.3 System Dependencies

In order to use this peripheral, other parts of the system must be configured correctly, as described below.

Table 13-1. CPUINT System Dependencies

Dependency	Applicable	Peripheral
Clocks	Yes	CLKCTRL
I/O Lines and Connections	No	-
Interrupts	No	-
Events	No	-
Debug	Yes	UPDI

#### Related Links

[13.2.3.5 Debug Operation](#)

[13.2.3.1 Clocks](#)

#### 13.2.3.1 Clocks

This peripheral depends on the peripheral clock.

#### Related Links

[10. CLKCTRL - Clock Controller](#)

#### 13.2.3.2 I/O Lines and Connections

Not applicable.

#### 13.2.3.3 Interrupts

Not applicable.

#### 13.2.3.4 Events

Not applicable.

### 13.2.3.5 Debug Operation

When run-time debugging, this peripheral will continue normal operation. Halting the CPU in Debugging mode will halt normal operation of the peripheral.

If the peripheral is configured to require periodical service by the CPU through interrupts or similar, improper operation or data loss may result during halted debugging.

#### Related Links

[33. UPDI - Unified Program and Debug Interface](#)

## 13.3 Functional Description

### 13.3.1 Initialization

An interrupt must be initialized in the following order:

1. Configure the CPUINT if the default configuration is not adequate (optional):
  - Vector handling is configured by writing to the respective bits (IVSEL and CVT) in the Control A register (CPUINT.CTRLA).
  - Vector prioritizing by round robin is enabled by writing a '1' to the Round Robin Priority Enable bit (LVL0RR) in CPUINT.CTRLA.
  - Select the priority level 1 vector by writing its address to the Interrupt Vector (LVL1VEC) in the Level 1 Priority register (CPUINT.LVL1VEC).
2. Configure the interrupt conditions within the peripheral, and enable the peripheral's interrupt.
3. Enable interrupts globally by writing a '1' to the Global Interrupt Enable bit (I) in the CPU Status register (CPU.SREG).

### 13.3.2 Operation

#### 13.3.2.1 Enabling, Disabling, and Resetting

Global enabling of interrupts is done by writing a '1' to the Global Interrupt Enable bit (I) in the CPU Status register (CPU.SREG). To disable interrupts globally, write a '0' to the I bit in CPU.SREG.

The desired interrupt lines must also be enabled in the respective peripheral, by writing to the peripheral's Interrupt Control register (*peripheral*.INTCTRL).

Interrupt flags are not automatically cleared after the interrupt is executed. The respective INTFLAGS register descriptions provide information on how to clear specific flags.

#### 13.3.2.2 Interrupt Vector Locations

The interrupt vector placement is dependent on the value of Interrupt Vector Select bit (IVSEL) in the Control A register (CPUINT.CTRLA). Refer to the IVSEL description in CPUINT.CTRLA for the possible locations.

If the program never enables an interrupt source, the interrupt vectors are not used, and regular program code can be placed at these locations.

#### 13.3.2.3 Interrupt Response Time

The minimum interrupt response time for all enabled interrupts is three CPU clock cycles: one cycle to finish the ongoing instruction, two cycles to store the Program Counter to the stack, and three cycles<sup>(1)</sup> to jump to the interrupt handler (*JMP*).

After the Program Counter is pushed on the stack, the program vector for the interrupt is executed. See [Figure 13-2](#), first diagram.

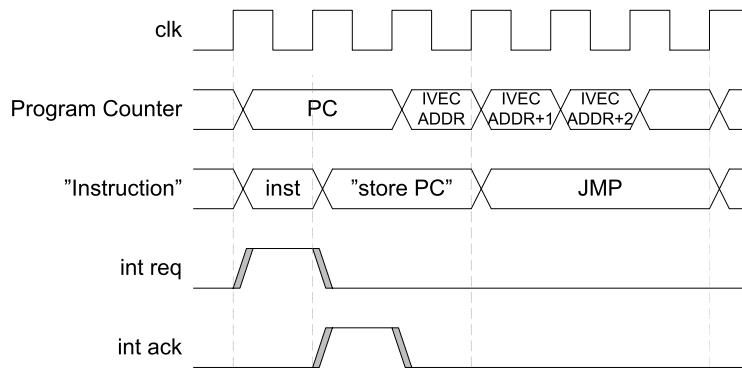
The jump to the interrupt handler takes three clock cycles<sup>(1)</sup>. If an interrupt occurs during execution of a multicycle instruction, this instruction is completed before the interrupt is served. See [Figure 13-2](#), second diagram.

If an interrupt occurs when the device is in sleep mode, the interrupt execution response time is increased by five clock cycles. In addition, the response time is increased by the start-up time from the selected sleep mode. See [Figure 13-2](#), third diagram.

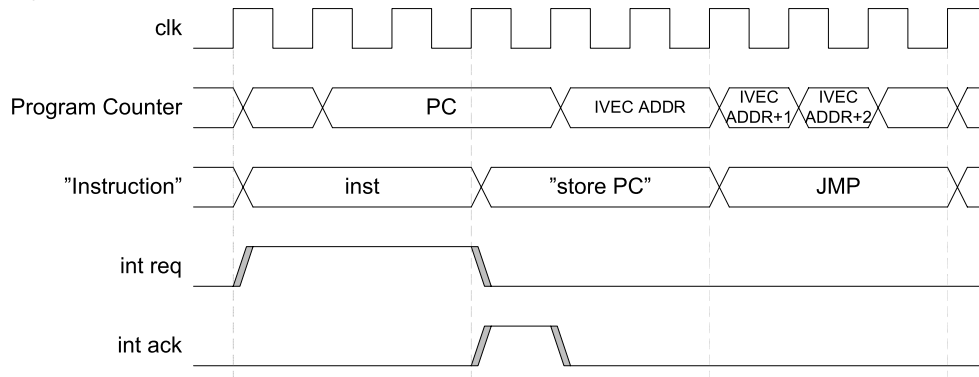
A return from an interrupt handling routine takes four to five clock cycles, depending on the size of the Program Counter. During these clock cycles, the Program Counter is popped from the stack and the Stack Pointer is incremented.

**Figure 13-2. Interrupt Execution of a Single-Cycle Instruction, Multicycle Instruction, and From Sleep<sup>(1)</sup>**

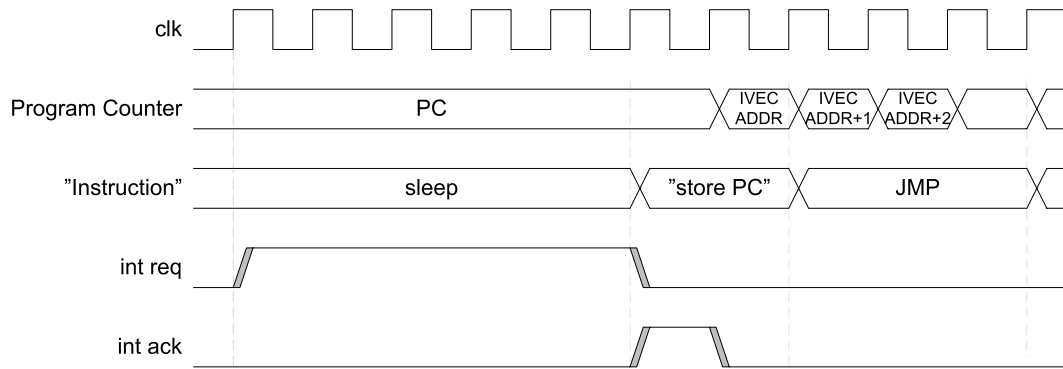
### Single-Cycle Instruction



### Multicycle Instruction



### Sleep



**Note:**

1. Devices with 8 KB of Flash or less use `RJMP` instead of `JMP`, which takes only two clock cycles.

#### 13.3.2.4 Interrupt Priority

All interrupt vectors are assigned to one of three possible priority levels as shown in the table. An interrupt request from a high priority source will interrupt any ongoing interrupt handler from a normal priority source. When returning from the high priority interrupt handler, the execution of the normal priority interrupt handler will resume.



**Table 13-2. Interrupt Priority Levels**

Priority	Level	Source
Highest	Non-Maskable Interrupt (NMI)	Device dependent and statically assigned
...	High Priority (Level 1)	One vector is optionally user selectable as Level 1
Lowest	Normal Priority (Level 0)	The remaining interrupt vectors

### 13.3.2.5 Scheduling of Normal Priority Interrupts

#### 13.3.2.5.1 Non-Maskable Interrupts (NMI)

An NMI will be executed regardless of the setting of the I bit in CPU.SREG, and it will never change the I bit. No other interrupt can interrupt an NMI handler. If more than one NMI is requested at the same time, priority is static according to the interrupt vector address, where the lowest address has the highest priority.

Which interrupts are non-maskable is device-dependent and not subject to configuration. Non-maskable interrupts must be enabled before they can be used. Refer to the Interrupt Vector Mapping of the device for available NMI lines.

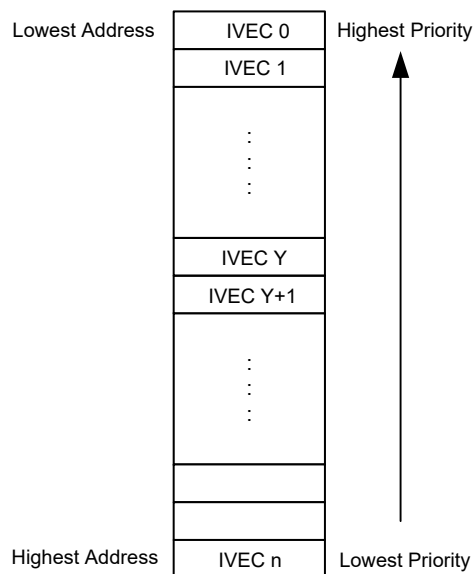
#### Related Links

[7.2 Interrupt Vector Mapping](#)

#### 13.3.2.5.2 Static Scheduling

If several level 0 interrupt requests are pending at the same time, the one with the highest priority is scheduled for execution first. The CPUINT.LVL0PRI register makes it possible to change the default priority. The Reset value for CPUINT.LVL0PRI is zero, resulting in a default priority as shown in the following figure. As the figure shows, IVEC0 has the highest priority, and IVECn has the lowest priority.

**Figure 13-3. Static Scheduling when CPUINT.LVL0PRI is Zero**

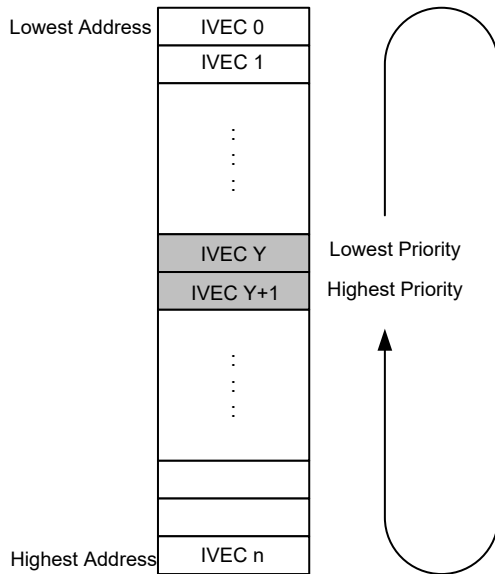


The default priority can be changed by writing to the CPUINT.LVL0PRI register. The value written to the register will identify the vector number with the lowest priority. The next interrupt vector in IVEC will have the highest priority, see the following figure. In this figure, the value Y has been written to

CPUINT.LVL0PRI, so that interrupt vector Y+1 has the highest priority. Note that in this case, the priorities will "wrap" so that IVEC0 has lower priority than IVECn.

Refer to the Interrupt Vector Mapping of the device for available interrupt requests and their interrupt vector number.

**Figure 13-4. Static Scheduling when CPUINT.LVL0PRI is Different From Zero**



**Related Links**

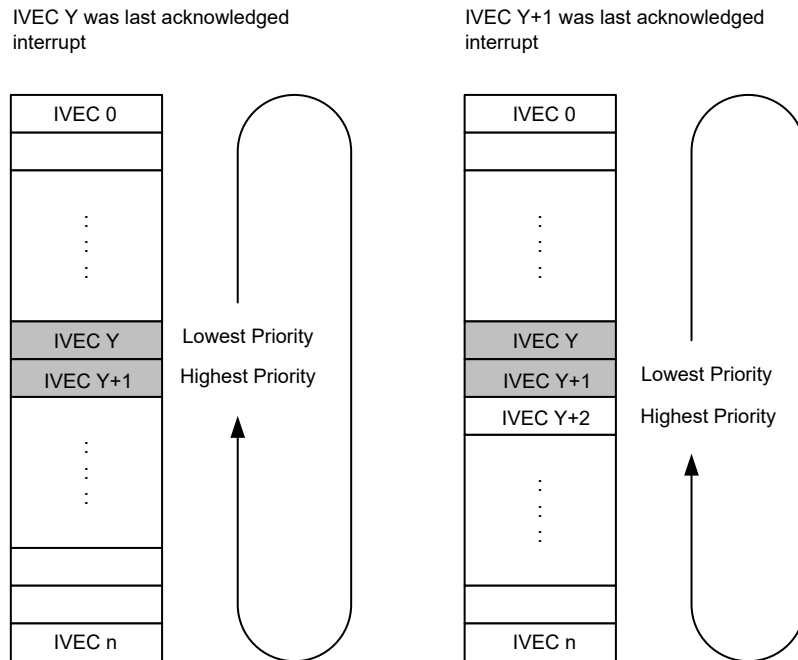
[7.2 Interrupt Vector Mapping](#)

**13.3.2.5.3 Round Robin Scheduling**

Static scheduling may cause starvation, i.e. some interrupts might never be serviced. To avoid this, the CPUINT offers round robin scheduling for normal priority (LVL0) interrupts. In round robin scheduling, CPUINT.LVL0PRI contains the number of the vector number in IVEC with the lowest priority. This register is automatically updated by hardware with the interrupt vector number for the last acknowledged LVL0 interrupt. This interrupt vector will, therefore, have the lowest priority next time one or more LVL0 interrupts are pending. [Figure 13-5](#) explains the new priority ordering after IVEC Y was the last interrupt to be acknowledged, and after IVEC Y+1 was the last interrupt to be acknowledged.

Round robin scheduling for LVL0 interrupt requests is enabled by writing a '1' to the Round Robin Priority Enable bit (LVL0RR) in the Control A register (CPUINT.CTRLA).

**Figure 13-5. Round Robin Scheduling**



#### 13.3.2.5.4 Compact Vector Table

The Compact Vector Table (CVT) is a feature to allow writing of compact code.

When CVT is enabled by writing a '1' to the CVT bit in the Control A register (CPUINT.CTRLA), the vector table contains these three interrupt vectors:

1. The non-maskable interrupts (NMI) at vector address 1.
2. The priority level 1 (LVL1) interrupt at vector address 2.
3. All priority level 0 (LVL0) interrupts share vector address 3.

This feature is most suitable for applications using a small number of interrupt generators.

#### 13.3.3 Events

Not applicable.

#### 13.3.4 Sleep Mode Operation

Not applicable.

#### 13.3.5 Configuration Change Protection

This peripheral has registers that are under Configuration Change Protection (CCP). In order to write to these, a certain key must be written to the CPU.CCP register first, followed by a write access to the protected bits within four CPU instructions.

Attempting to write to a protected register without following the appropriate CCP unlock sequence leaves the protected register unchanged.

The following registers are under CCP:

**Table 13-3. INTCTRL - Registers under Configuration Change Protection**

Register	Key
IVSEL in CPUINT.CTRLA	IOREG
CVT in CPUINT.CTRLA	IOREG

**Related Links**

[8.5.7.1 Sequence for Write Operation to Configuration Change Protected I/O Registers](#)

### 13.4 Register Summary - CPUINT

Offset	Name	Bit Pos.								
0x00	<a href="#">CTRLA</a>	7:0		IVSEL	CVT					LVL0RR
0x01	<a href="#">STATUS</a>	7:0	NMIEX						LVL1EX	LVL0EX
0x02	<a href="#">LVL0PRI</a>	7:0	LVL0PRI[7:0]							
0x03	<a href="#">LVL1VEC</a>	7:0	LVL1VEC[7:0]							

### 13.5 Register Description

### 13.5.1 Control A

**Name:** CTRLA  
**Offset:** 0x00  
**Reset:** 0x00  
**Property:** Configuration Change Protection

Bit	7	6	5	4	3	2	1	0
		IVSEL	CVT					LVL0RR
Access		R/W	R/W					R/W
Reset		0	0					0

#### Bit 6 – IVSEL Interrupt Vector Select

If the boot section is defined, it will be placed before the application section. The actual start address of the application section is determined by the BOOTEND fuse.

This bit is protected by the Configuration Change Protection mechanism.

Value	Description
0	Interrupt vectors are placed at the start of the application section of the Flash
1	Interrupt vectors are placed at the start of the boot section of the Flash

#### Bit 5 – CVT Compact Vector Table

This bit is protected by the Configuration Change Protection mechanism.

Value	Description
0	Compact Vector Table function is disabled
1	Compact Vector Table function is enabled

#### Bit 0 – LVL0RR Round Robin Priority Enable

This bit is not protected by the Configuration Change Protection mechanism.

Value	Description
0	Priority is fixed for priority level 0 interrupt requests: The lowest interrupt vector address has the highest priority.
1	Round Robin priority scheme is enabled for priority level 0 interrupt requests

### 13.5.2 Status

**Name:** STATUS  
**Offset:** 0x01  
**Reset:** 0x00  
**Property:** -

	7	6	5	4	3	2	1	0
	NMIEX						LVL1EX	LVL0EX
Access	R						R	R
Reset	0						0	0

**Bit 7 – NMIEX** Non-Maskable Interrupt Executing

This flag is set if a non-maskable interrupt is executing. The flag is cleared when returning (RETI) from the interrupt handler.

**Bit 1 – LVL1EX** Level 1 Interrupt Executing

This flag is set when a priority level 1 interrupt is executing, or when the interrupt handler has been interrupted by an NMI. The flag is cleared when returning (RETI) from the interrupt handler.

**Bit 0 – LVL0EX** Level 0 Interrupt Executing

This flag is set when a priority level 0 interrupt is executing, or when the interrupt handler has been interrupted by a priority level 1 interrupt or an NMI. The flag is cleared when returning (RETI) from the interrupt handler.

### 13.5.3 Interrupt Priority Level 0

**Name:** LVL0PRI  
**Offset:** 0x02  
**Reset:** 0x00  
**Property:** -

Bit	7	6	5	4	3	2	1	0
	LVL0PRI[7:0]							
Access	R/W	R/W	R/W	R/W	R/W	R/W	R/W	R/W
Reset	0	0	0	0	0	0	0	0

**Bits 7:0 – LVL0PRI[7:0] Interrupt Priority Level 0**

When Round Robin is enabled (the LVL0RR bit in CPUINT.CTRLA is '1'), this bit field stores the vector of the last acknowledged priority level 0 (LVL0) interrupt. The stored vector will have the lowest priority next time one or more LVL0 interrupts are pending.

If Round Robin is disabled (the LVL0RR bit in CPUINT.CTRLA is '0'), the vector address-based priority scheme (lowest address has the highest priority) is governing the priorities of LVL0 interrupt requests.

If a system Reset is asserted, the lowest interrupt vector address will have the highest priority within the LVL0.



**13.5.4 Interrupt Vector with Priority Level 1**

**Name:** LVL1VEC  
**Offset:** 0x03  
**Reset:** 0x00  
**Property:** -

Bit	7	6	5	4	3	2	1	0
	LVL1VEC[7:0]							
Access	R/W	R/W	R/W	R/W	R/W	R/W	R/W	R/W
Reset	0	0	0	0	0	0	0	0

**Bits 7:0 – LVL1VEC[7:0] Interrupt Vector with Priority Level 1**

This bit field contains the number of the single vector with increased priority level 1 (LVL1).

If this bit field has the value 0x00, no vector has LVL1. Consequently, the LVL1 interrupt is disabled.

## 14. EVSYS - Event System

### 14.1 Features

- System for Direct Peripheral-to-Peripheral Signaling
- Peripherals can Directly Produce, Use, and React to Peripheral Events
- Short Response Time
- Up to Six Parallel Event Channels Available; Four Asynchronous and Two Synchronous
- Channels can be Configured to Have One Triggering Peripheral Action and Multiple Peripheral Users
- Peripherals can Directly Trigger and React to Events from Other Peripherals
- Events can be Sent and/or Received by Most Peripherals, and by Software
- Works in Active mode and Standby Sleep mode

### 14.2 Overview

The Event System (EVSYS) enables direct peripheral-to-peripheral signaling. It allows a change in one peripheral (the event generator) to trigger actions in other peripherals (the event users) through event channels, without using the CPU. It is designed to provide short and predictable response times between peripherals, allowing for autonomous peripheral control and interaction, and also for the synchronized timing of actions in several peripheral modules. It is thus a powerful tool for reducing the complexity, size, and the execution time of the software.

A change of the event generator's state is referred to as an event and usually corresponds to one of the peripheral's interrupt conditions. Events can be directly forwarded to other peripherals using the dedicated event routing network. The routing of each channel is configured in software, including event generation and use.

Only one trigger from an event generator peripheral can be routed on each channel, but multiple channels can use the same generator source. Multiple peripherals can use events from the same channel.

A channel path can be either asynchronous or synchronous to the main clock. The mode must be selected based on the requirements of the application.

The Event System can directly connect analog and digital converters, analog comparators, I/O port pins, the real-time counter, timer/counters, and the configurable custom logic peripheral. Events can also be generated from software and the peripheral clock.

14.2.1 Block Diagram

Figure 14-1. Block Diagram

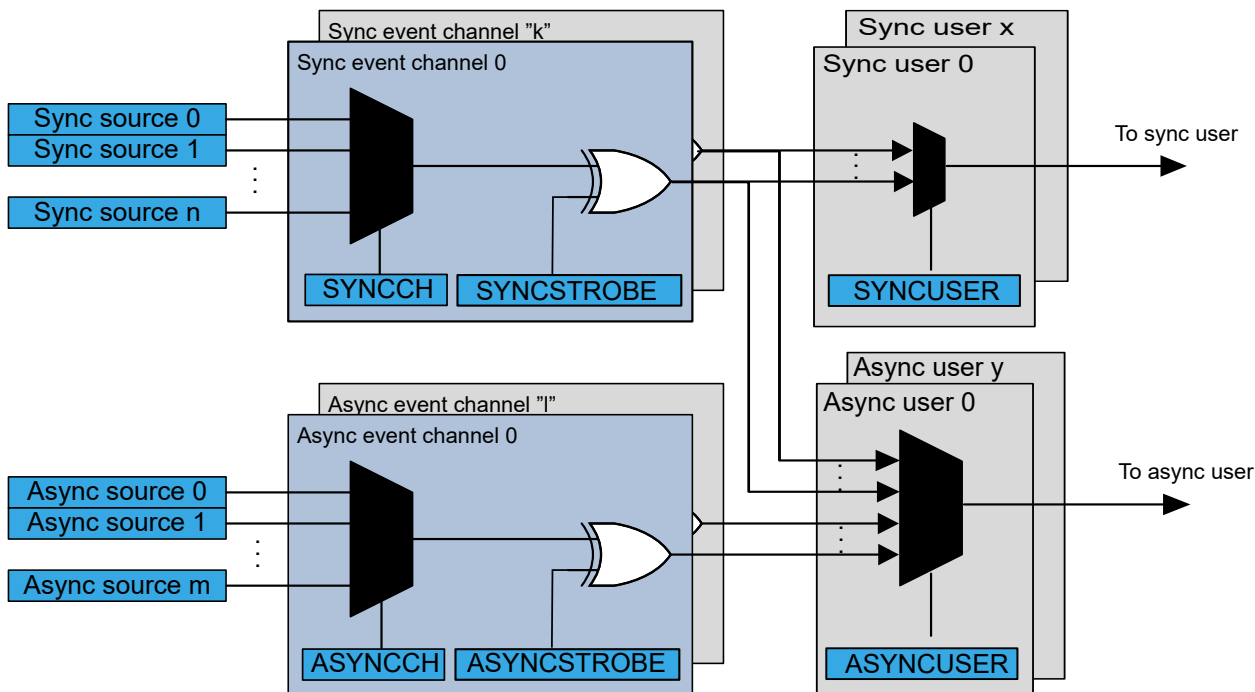
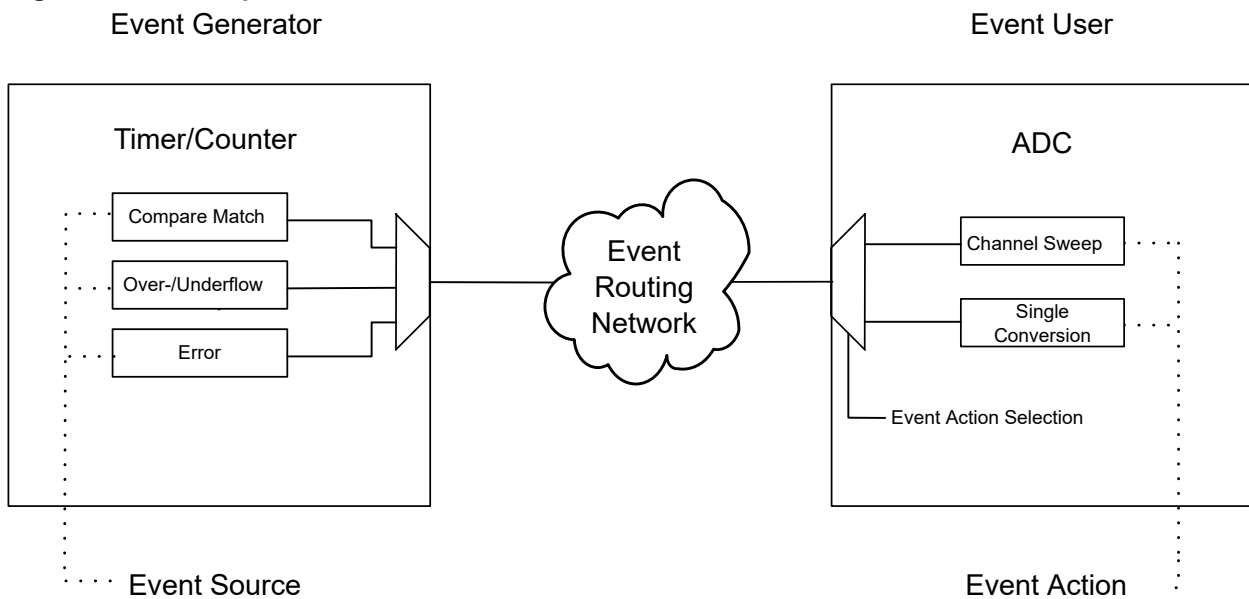


Figure 14-2. Example of Event Source, Generator, User, and Action



**Note:**

1. For an overview of peripherals supporting events, refer the block diagram of the device.
2. For a list of event generators, refer to the Channel n Generator Selection registers (EVSYS.SYNCCH and EVSYS.ASYNCCH).
3. For a list of event users, refer to the User Channel n Input Selection registers (EVSYS.SYNCUSER and EVSYS.ASYNCUSER).

**Related Links**

- [14.5.4 SYNCCH](#)
- [14.5.3 ASYNCCH](#)
- [14.5.6 SYNCUSER](#)
- [14.5.5 ASYNCUSER](#)

## 14.2.2 Signal Description

### Internal Event Signaling

The event signaling can happen either synchronously or asynchronously to the main clock (CLK\_MAIN). Depending on the underlying event, the event signal can be a pulse with a duration of one clock cycle, or a level signal (similar to a status flag).

### Event Output to Pin

Signal	Type	Description
EVOUT[2:0]	Digital Output	Event Output

### Related Links

- [14.2.3.2 I/O Lines](#)
- [10.2.1 Block Diagram - CLKCTRL](#)

## 14.2.3 System Dependencies

In order to use this peripheral, other parts of the system must be configured correctly, as described below.

**Table 14-1. EVSYS System Dependencies**

Dependency	Applicable	Peripheral
Clocks	Yes	CLKCTRL
I/O Lines and Connections	Yes	PORTMUX
Interrupts	No	-
Events	Yes	EVSYS
Debug	Yes	UPDI

### Related Links

- [14.2.3.1 Clocks](#)
- [14.3.5 Debug Operation](#)

### 14.2.3.1 Clocks

The EVSYS uses the peripheral clock for I/O registers and software events. When correctly set up, the routing network can also be used in sleep modes without any clock. Software events will not work in sleep modes where the peripheral clock is halted.

### Related Links

- [10. CLKCTRL - Clock Controller](#)

### 14.2.3.2 I/O Lines

The EVSYS can output three event channels asynchronously on pins. The output signals are called EVOUT[2:0].

1. Configure which event channel (one of SYNCCH[1:0] or ASYNCCH[3:0]) is output on which EVOUTn bit by writing to EVSYS.ASYNCUSER10, EVSYS.ASYNCUSER9, or EVSYS.ASYNCUSER8, respectively.
2. Optional: configure the pin properties using the port peripheral.
3. Enable the pin output by writing '1' to the respective EVOUTn bit in the Control A register of the PORTMUX peripheral (PORTMUX.CTRLA).

#### Related Links

[15. PORTMUX - Port Multiplexer](#)

[16. PORT - I/O Pin Configuration](#)

[14.5.5 ASYNCUSER](#)

## 14.3 Functional Description

### 14.3.1 Initialization

Before enabling events within the device, the event users multiplexer and event channels must be configured.

#### Related Links

[14.3.2.1 Event User Multiplexer Setup](#)

[14.3.2.2 Event System Channel](#)

### 14.3.2 Operation

#### 14.3.2.1 Event User Multiplexer Setup

The event user multiplexer selects the channel for an event user. Each event user has one dedicated event user multiplexer. Each multiplexer is connected to the supported event channel outputs and can be configured to select one of these channels.

Event users, which support asynchronous events, also support synchronous events. There are also event users that support only synchronous events.

The event user multiplexers are configured by writing to the corresponding registers:

- Event users supporting both synchronous and asynchronous events are configured by writing to the respective asynchronous User Channel Input Selection n register (EVSYS.ASYNCUSERn).
- The users of synchronous-only events are configured by writing to the respective Synchronous User Channel Input Selection n register (EVSYS.SYNCUSERn).

The default setup of all user multiplexers is OFF.

#### 14.3.2.2 Event System Channel

An event channel can be connected to one of the event generators. Event channels support either asynchronous generators or synchronous generators.

The source for each asynchronous event channel is configured by writing to the respective Asynchronous Channel n Input Selection register (EVSYS.ASYNCCHn).

The source for each synchronous event channel is configured by writing to the respective Synchronous Channel n Input Selection register (EVSYS.SYNCCHn).

#### 14.3.2.3 Event Generators

Each event channel can receive the events from several event generators. For details on event generation, refer to the documentation of the corresponding peripheral.

For each event channel, there are several possible event generators, only one of which can be selected at a time. The event generator trigger is selected for each channel by writing to the respective channel registers (EVSYS.ASYNCCHn, EVSYS.SYNCCHn). By default, the channels are not connected to any event generator.

#### 14.3.2.4 Software Event

In a software event, the CPU will “strobe” an event channel by inverting the current value for one system clock cycle.

A software event is triggered on a channel by writing a '1' to the respective Strobe bit in the appropriate Channel Strobe register:

- Software events on asynchronous channel *l* are initiated by writing a '1' to the ASYNCSTROBE[*l*] bit in the Asynchronous Channel Strobe register (EVSYS.ASYNCSTROBE).
- Software events on synchronous channel *k* are initiated by writing a '1' to the SYNCSTROBE[*k*] bit in the Synchronous Channel Strobe register (EVSYS.SYNCSTROBE).

Software events are no different to those produced by event generator peripherals with respect to event users: when the bit is written to '1', an event will be generated on the respective channel, and received and processed by the event user.

#### 14.3.3 Interrupts

Not applicable.

#### 14.3.4 Sleep Mode Operation

When configured, the Event System will work in all sleep modes. One exception is software events that require a system clock.

#### 14.3.5 Debug Operation

This peripheral is unaffected by entering Debug mode.

##### Related Links

[33. UPDI - Unified Program and Debug Interface](#)

#### 14.3.6 Synchronization

Asynchronous events are synchronized and handled by the compatible event users. Event user peripherals not compatible with asynchronous events can only be configured to listen to synchronous event channels.

#### 14.3.7 Configuration Change Protection

Not applicable.

##### Related Links

[8.5.7.1 Sequence for Write Operation to Configuration Change Protected I/O Registers](#)

## 14.4 Register Summary - EVSYS

Offset	Name	Bit Pos.								
0x00	ASYNCSTROBE	7:0	ASYNCSTROBE[7:0]							
0x01	SYNCSTROBE	7:0	SYNCSTROBE[7:0]							
0x02	ASYNCCH0	7:0	ASYNCCH[7:0]							
0x03	ASYNCCH1	7:0	ASYNCCH[7:0]							
0x04	ASYNCCH2	7:0	ASYNCCH[7:0]							
0x05	ASYNCCH3	7:0	ASYNCCH[7:0]							
0x06 ... 0x09	Reserved									
0x0A	SYNCCH0	7:0	SYNCCH[7:0]							
0x0B	SYNCCH1	7:0	SYNCCH[7:0]							
0x0C ... 0x11	Reserved									
0x12	ASYNCUSER0	7:0	ASYNCUSER[7:0]							
0x13	ASYNCUSER1	7:0	ASYNCUSER[7:0]							
0x14	ASYNCUSER2	7:0	ASYNCUSER[7:0]							
0x15	ASYNCUSER3	7:0	ASYNCUSER[7:0]							
0x16	ASYNCUSER4	7:0	ASYNCUSER[7:0]							
0x17	ASYNCUSER5	7:0	ASYNCUSER[7:0]							
0x18	ASYNCUSER6	7:0	ASYNCUSER[7:0]							
0x19	ASYNCUSER7	7:0	ASYNCUSER[7:0]							
0x1A	ASYNCUSER8	7:0	ASYNCUSER[7:0]							
0x1B	ASYNCUSER9	7:0	ASYNCUSER[7:0]							
0x1C	ASYNCUSER10	7:0	ASYNCUSER[7:0]							
0x1D	ASYNCUSER11	7:0	ASYNCUSER[7:0]							
0x1E	ASYNCUSER12	7:0	ASYNCUSER[7:0]							
0x1F ... 0x21	Reserved									
0x22	SYNCUSER0	7:0	SYNCUSER[7:0]							
0x23	SYNCUSER1	7:0	SYNCUSER[7:0]							

## 14.5 Register Description

**14.5.1 Asynchronous Channel Strobe**

**Name:** ASYNCSTROBE  
**Offset:** 0x00  
**Reset:** 0x00  
**Property:** -

Bit	7	6	5	4	3	2	1	0
	ASYNCSTROBE[7:0]							
Access	R/W	R/W	R/W	R/W	R/W	R/W	R/W	R/W
Reset	0	0	0	0	0	0	0	0

**Bits 7:0 – ASYNCSTROBE[7:0]** Asynchronous Channel Strobe

If the Strobe register location is written, each event channel will be inverted for one system clock cycle (i.e., a single event is generated).



**14.5.2 Synchronous Channel Strobe**

**Name:** SYNCSTROBE  
**Offset:** 0x01  
**Reset:** 0x00  
**Property:** -

Bit	7	6	5	4	3	2	1	0
	SYNCSTROBE[7:0]							
Access	R/W	R/W	R/W	R/W	R/W	R/W	R/W	R/W
Reset	0	0	0	0	0	0	0	0

**Bits 7:0 – SYNCSTROBE[7:0] Synchronous Channel Strobe**

If the Strobe register location is written, each event channel will be inverted for one system clock cycle (i.e., a single event is generated).

### 14.5.3 Asynchronous Channel n Generator Selection

**Name:** ASYNCCH  
**Offset:** 0x02 + n\*0x01 [n=0..3]  
**Reset:** 0x00  
**Property:** -

Bit	7	6	5	4	3	2	1	0
	ASYNCCH[7:0]							
Access	R/W	R/W	R/W	R/W	R/W	R/W	R/W	R/W
Reset	0	0	0	0	0	0	0	0

**Bits 7:0 – ASYNCCH[7:0]** Asynchronous Channel Generator Selection

**Table 14-2. Asynchronous Channel Generator Selection**

Value	ASYNCCH0	ASYNCCH1	ASYNCCH2	ASYNCCH3
0x00	OFF	OFF	OFF	OFF
0x01	CCL_LUT0			
0x02	CCL_LUT1			
0x03	AC0_OUT			
0x04	TCD0_CMPBCLR			
0x05	TCD0_CMPASET			
0x06	TCD0_CMPBSET			
0x07	TCD0_PROGEV			
0x08	RTC_OVF			
0x09	RTC_CMP			
0x0A	PORTA_PIN0	PORTB_PIN0	-	PIT_DIV8192
0x0B	PORTA_PIN1	PORTB_PIN1	-	PIT_DIV4096
0x0C	PORTA_PIN2	PORTB_PIN2	-	PIT_DIV2048
0x0D	PORTA_PIN3	PORTB_PIN3	-	PIT_DIV1024
0x0E	PORTA_PIN4	PORTB_PIN4	-	PIT_DIV512
0x0F	PORTA_PIN5	PORTB_PIN5	-	PIT_DIV256
0x10	PORTA_PIN6	PORTB_PIN6	AC1_OUT-	PIT_DIV128
0x11	PORTA_PIN7	PORTB_PIN7	AC2_OUT-	PIT_DIV64
0x12	UPDI	AC1_OUT	-	AC1_OUT
0x13	AC1_OUT	AC2_OUT	-	AC2_OUT

Value	ASYNCCH0	ASYNCCH1	ASYNCCH2	ASYNCCH3
0x14	AC2_OUT	-	-	-
Other	-	-	-	-

**Note:** Not all pins of a port are actually available on devices with low pin counts. Check the Pinout Diagram and/or the I/O Multiplexing table for details.

#### Related Links

- [4. Pinout](#)
- [5. I/O Multiplexing and Considerations](#)

### 14.5.4 Synchronous Channel n Generator Selection

**Name:** SYNCCH  
**Offset:** 0x0A + n\*0x01 [n=0..1]  
**Reset:** 0x00  
**Property:** -

Bit	7	6	5	4	3	2	1	0
	SYNCCH[7:0]							
Access	R/W	R/W	R/W	R/W	R/W	R/W	R/W	R/W
Reset	0	0	0	0	0	0	0	0

**Bits 7:0 – SYNCCH[7:0]** Synchronous Channel Generator Selection

**Table 14-3. Synchronous Channel Generator Selection**

Value	SYNCCH0	SYNCCH1
0x00	OFF	
0x01	TCB0	
0x02	TCA0_OVF_LUNF	
0x03	TCA0_HUNF	
0x04	TCA0_CMP0	
0x05	TCA0_CMP1	
0x06	TCA0_CMP2	
0x07	-	-
0x08	-	PORTB_PIN0
0x09	-	PORTB_PIN1
0x0A	-	PORTB_PIN2
0x0B	-	PORTB_PIN3
0x0C	-	PORTB_PIN4
0x0D	PORTA_PIN0	PORTB_PIN5
0x0E	PORTA_PIN1	PORTB_PIN6
0x0F	PORTA_PIN2	PORTB_PIN7
0x10	PORTA_PIN3	TCB1
0x11	PORTA_PIN4	-
0x12	PORTA_PIN5	-
0x13	PORTA_PIN6	-
0x14	PORTA_PIN7	-

---

---

Value	SYNCCH0	SYNCCH1
0x15	TCB1	-
Other	-	-

### 14.5.5 Asynchronous User Channel n Input Selection

**Name:** ASYNCUSER  
**Offset:** 0x12 + n\*0x01 [n=0..12]  
**Reset:** 0x00  
**Property:** -

Bit	7	6	5	4	3	2	1	0
	ASYNCUSER[7:0]							
Access	R/W	R/W	R/W	R/W	R/W	R/W	R/W	R/W
Reset	0	0	0	0	0	0	0	0

**Bits 7:0 – ASYNCUSER[7:0]** Asynchronous User Channel Selection

**Table 14-4. User Multiplexer Numbers**

USERn	User Multiplexer	Description
n=0	TCB0	Timer/Counter B 0
n=1	ADC0	ADC 0
n=2	CCL_LUT0EV0	CCL LUT0 Event 0
n=3	CCL_LUT1EV0	CCL LUT1 Event 0
n=4	CCL_LUT0EV1	CCL LUT0 Event 1
n=5	CCL_LUT1EV1	CCL LUT1 Event 1
n=6	TCD0_EV0	Timer Counter D 0 Event 0
n=7	TCD0_EV1	Timer Counter D 0 Event 1
n=8	EVOUT0	Event OUT 0
n=9	EVOUT1	Event OUT 1
n=10	EVOUT2	Event OUT 2
n=11	TCB1	Timer/Counter B 1
n=12	ADC1	ADC 1

Value	Description
0x0	OFF
0x1	SYNCCH0
0x2	SYNCCH1
0x3	ASYNCCH0
0x4	ASYNCCH1
0x5	ASYNCCH2
0x6	ASYNCCH3

### 14.5.6 Synchronous User Channel n Input Selection

**Name:** SYNCUSER  
**Offset:** 0x22 + n\*0x01 [n=0..1]  
**Reset:** 0x00  
**Property:** -

Bit	7	6	5	4	3	2	1	0
	SYNCUSER[7:0]							
Access	R/W	R/W	R/W	R/W	R/W	R/W	R/W	R/W
Reset	0	0	0	0	0	0	0	0

**Bits 7:0 – SYNCUSER[7:0]** Synchronous User Channel Selection

**Table 14-5. User Multiplexer Numbers**

USERn	User Multiplexer	Description
n=0	TCA0	Timer/Counter A
n=1	USART0	USART

Value	Name
0x0	OFF
0x1	SYNCCH0
0x2	SYNCCH1

## 15. PORTMUX - Port Multiplexer

### 15.1 Overview

The Port Multiplexer (PORTMUX) can either enable or disable functionality of pins, or change between default and alternative pin positions. This depends on the actual pin and property and is described in detail in the PORTMUX register map.

For available pins and functionalities, refer to the Multiplexed Signals table.

#### **Related Links**

[5. I/O Multiplexing and Considerations](#)



## 15.2 Register Summary - PORTMUX

Offset	Name	Bit Pos.								
0x00	<a href="#">CTRLA</a>	7:0							EVOUT1	EVOUT0
0x01	<a href="#">CTRLB</a>	7:0						SPI0		USART0
0x02	<a href="#">CTRLC</a>	7:0								TCA00

## 15.3 Register Description

**15.3.1 Control A**

**Name:** CTRLA  
**Offset:** 0x00  
**Reset:** 0x00  
**Property:** -

	7	6	5	4	3	2	1	0
							EVOUT1	EVOUT0
Access							R/W	R/W
Reset							0	0

**Bit 1 – EVOUT1** Event Output 1  
 Write this bit to '1' to enable event output 1.

**Bit 0 – EVOUT0** Event Output 0  
 Write this bit to '1' to enable event output 0.

### 15.3.2 Control B

**Name:** CTRLB  
**Offset:** 0x01  
**Reset:** 0x00  
**Property:** -

	7	6	5	4	3	2	1	0
						SPI0		USART0
Access						R/W		R/W
Reset						0		0

**Bit 2 – SPI0** SPI 0 communication

Write this bit to '1' to select alternative communication pins for SPI 0.

**Bit 0 – USART0** USART 0 communication

Write this bit to '1' to select alternative communication pins for USART 0.

**15.3.3 Control C**

**Name:** CTRLC  
**Offset:** 0x02  
**Reset:** 0x00  
**Property:** -

Bit	7	6	5	4	3	2	1	0
								TCA00
Access								R/W
Reset								0

**Bit 0 – TCA00** TCA0 Waveform output 0

Write this bit to '1' to select alternative output pin for TCA0 waveform output 0.

In Split mode, this bit controls output from low byte compare channel 0.

## 16. PORT - I/O Pin Configuration

### 16.1 Features

- General Purpose Input and Output Pins with Individual Configuration
- Output Driver with Configurable Inverted I/O and Pull-up
- Input with Interrupts and Events:
  - Sense both edges
  - Sense rising edges
  - Sense falling edges
  - Sense low level
- Asynchronous Pin Change Sensing That Can Wake the Device From all Sleep Modes
- Efficient and Safe Access to Port Pins
  - Hardware read-modify-write through dedicated toggle/clear/set registers
  - Mapping of often-used PORT registers into bit-accessible I/O memory space (virtual ports)

### 16.2 Overview

The I/O pins of the device are controlled by instances of the Port Peripheral registers. This device has the following instances of the I/O pin configuration (PORT): PORTA, PORTB.

Refer to the I/O multiplexing table to see which pins are controlled by what instance of port. The offsets of the port instances and of the corresponding virtual port instances are listed in the Peripherals and Architecture section.

Each of the port pins has a corresponding bit in the Data Direction (PORT.DIR) and Data Output Value (PORT.OUT) registers to enable that pin as an output and to define the output state. For example, pin PA3 is controlled by DIR[3] and OUT[3] of the PORTA instance.

The Data Input Value (PORT.IN) is set as the input value of a port pin with resynchronization to the main clock. To reduce power consumption, these input synchronizers are not clocked if the Input Sense Configuration bit field (ISC) in PORT.PINnCTRL is INPUT\_DISABLE. The value of the pin can always be read, whether the pin is configured as input or output.

The port supports synchronous and asynchronous input sensing with interrupts for selectable pin change conditions. Asynchronous pin-change sensing means that a pin change can wake the device from all sleep modes, including the modes where no clocks are running.

All pin functions are configurable individually per pin. The pins have hardware read-modify-write (RMW) functionality for a safe and correct change of drive value and/or pull resistor configuration. The direction of one port pin can be changed without unintentionally changing the direction of any other pin.

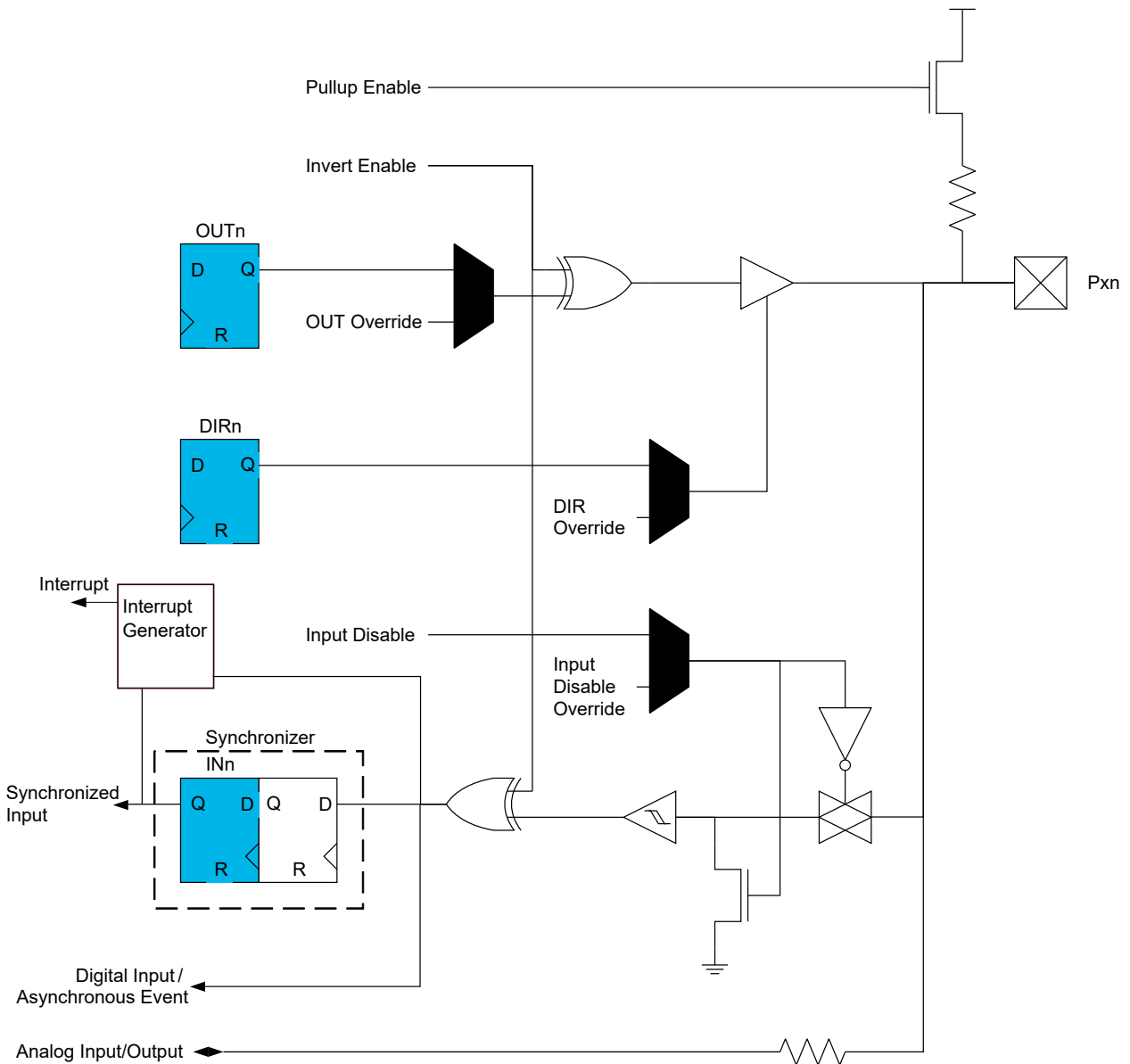
The port pin configuration controls input and output selection of other device functions.

#### Related Links

- [5. I/O Multiplexing and Considerations](#)
- [7. Peripherals and Architecture](#)

### 16.2.1 Block Diagram

Figure 16-1. PORT Block Diagram



### 16.2.2 Signal Description

Signal	Type	Description
Pxn	I/O pin	I/O pin n on PORTx

#### Related Links

[5. I/O Multiplexing and Considerations](#)

### 16.2.3 System Dependencies

In order to use this peripheral, other parts of the system must be configured correctly, as described below.

**Table 16-1. PORT System Dependencies**

Dependency	Applicable	Peripheral
Clocks	Yes	CLKCTRL
I/O Lines and Connections	No	-
Interrupts	Yes	CPUINT
Events	Yes	EVSYS
Debug	No	-

**Related Links**

- [16.2.3.4 Events](#)
- [16.2.3.1 Clocks](#)
- [16.2.3.3 Interrupts](#)

**16.2.3.1 Clocks**

This peripheral depends on the peripheral clock.

**16.2.3.2 I/O Lines and Connections**

Not applicable.

**16.2.3.3 Interrupts**

Using the interrupts of this peripheral requires the interrupt controller to be configured first.

**Related Links**

- [13. CPUINT - CPU Interrupt Controller](#)
- [16.3.3 Interrupts](#)
- [8.7.3 SREG](#)

**16.2.3.4 Events**

The events of this peripheral are connected to the Event System.

**Related Links**

- [14. EVSYS - Event System](#)

**16.2.3.5 Debug Operation**

This peripheral is unaffected by entering Debug mode.

## 16.3 Functional Description

**16.3.1 Initialization**

After Reset, all standard function device I/O pads are connected to the port with outputs tri-stated and input buffers enabled, even if there is no clock running.

Power consumption can be reduced by disabling digital input buffers for all unused pins and for pins used as analog inputs or outputs.

Specific pins, such as those used for connecting a debugger, may be configured differently, as required by their special function.

### 16.3.2 Operation

#### 16.3.2.1 Basic Functions

Each I/O pin P<sub>xn</sub> can be controlled by the registers in PORT<sub>x</sub>. Each pin group x has its own set of PORT registers. The base address of the register set for pin n is at the byte address PORT + 0x10 + n. The index within that register set is n.

To use pin number n as an output only, write bit n of the PORT<sub>x</sub>.DIR register to '1'. This can be done by writing bit n in the PORT<sub>x</sub>.DIRSET register to '1', which will avoid disturbing the configuration of other pins in that group. The n<sup>th</sup> bit in the PORT<sub>x</sub>.OUT register must be written to the desired output value.

Similarly, writing a PORT<sub>x</sub>.OUTSET bit to '1' will set the corresponding bit in the PORT<sub>x</sub>.OUT register to '1'. Writing a bit in PORT<sub>x</sub>.OUTCLR to '1' will clear that bit in PORT<sub>x</sub>.OUT to zero. Writing a bit in PORT<sub>x</sub>.OUTTGL or PORT<sub>x</sub>.IN to '1' will toggle that bit in PORT<sub>x</sub>.OUT.

To use pin n as an input, bit n in the PORT<sub>x</sub>.DIR register must be written to '0' to disable the output driver. This can be done by writing bit n in the PORT<sub>x</sub>.DIRCLR register to '1', which will avoid disturbing the configuration of other pins in that group. The input value can be read from bit n in register PORT<sub>x</sub>.IN as long as the ISC bit is not set to INPUT\_DISABLE.

Writing a bit to '1' in PORT<sub>x</sub>.DIRTGL will toggle that bit in PORT<sub>x</sub>.DIR and toggle the direction of the corresponding pin.

#### 16.3.2.2 Virtual Ports

The Virtual PORT registers map the most frequently used regular PORT registers into the bit-accessible I/O space. Writing to the Virtual PORT registers has the same effect as writing to the regular registers, but allows for memory-specific instructions, such as bit-manipulation instructions, which are not valid for the extended I/O memory space where the regular PORT registers reside.

**Table 16-2. Virtual Port Mapping**

Regular PORT Register	Mapped to Virtual PORT Register
PORT.DIR	VPORT.DIR
PORT.OUT	VPORT.OUT
PORT.IN	VPORT.IN
PORT.INTFLAG	VPORT.INTFLAG

#### Related Links

- [16.6 Register Summary - VPORT](#)
- [5. I/O Multiplexing and Considerations](#)
- [7. Peripherals and Architecture](#)

#### 16.3.2.3 Pin Configuration

The Pin n Configuration register (PORT.PINnCTRL) is used to configure inverted I/O, pullup, and input sensing of a pin.

All input and output on the respective pin n can be inverted by writing a '1' to the Inverted I/O Enable bit (INVEN) in PORT.PINnCTRL.

Toggling the INVEN bit causes an edge on the pin, which can be detected by all peripherals using this pin, and is seen by interrupts or events if enabled.

Pullup of pin n is enabled by writing a '1' to the Pullup Enable bit (PULLUPEN) in PORT.PINnCTRL.



Changes of the signal on a pin can trigger an interrupt. The exact conditions are defined by writing to the Input/Sense bit field (ISC) in PORT.PINnCTRL.

When setting or changing interrupt settings, take these points into account:

- If an INVEN bit is toggled in the same cycle as the interrupt setting, the edge caused by the inversion toggling may not cause an interrupt request.
- If an input is disabled while synchronizing an interrupt, that interrupt may be requested on re-enabling the input, even if it is re-enabled with a different interrupt setting.
- If the interrupt setting is changed while synchronizing an interrupt, that interrupt may not be accepted.
- Only a few pins support full asynchronous interrupt detection, see I/O Multiplexing and Considerations. These limitations apply for waking the system from sleep:

Interrupt Type	Fully Asynchronous Pins	Other Pins
BOTHEGES	Will wake the system	Will wake the system
RISING	Will wake the system	Will not wake the system
FALLING	Will wake the system	Will not wake the system
LEVEL	Will wake the system	Will wake the system

### Related Links

[5. I/O Multiplexing and Considerations](#)

### 16.3.3 Interrupts

**Table 16-3. Available Interrupt Vectors and Sources**

Offset	Name	Vector Description	Conditions
0x00	PORTx	PORT A, B, C interrupt	INTn in PORT.INTFLAGS is raised as configured by ISC bit in PORT.PINnCTRL.

Each port pin *n* can be configured as an interrupt source. Each interrupt can be individually enabled or disabled by writing to ISC in PORT.PINCTRL.

When an interrupt condition occurs, the corresponding interrupt flag is set in the Interrupt Flags register of the peripheral (*peripheral*.INTFLAGS).

An interrupt request is generated when the corresponding interrupt is enabled and the interrupt flag is set. The interrupt request remains active until the interrupt flag is cleared. See the peripheral's INTFLAGS register for details on how to clear interrupt flags.

### Asynchronous Sensing Pin Properties

**Table 16-4. Behavior Comparison of Fully/Partly Asynchronous Sense Pin**

Property	Synchronous or Partly Asynchronous Sense Support	Full Asynchronous Sense Support
Minimum pulse-width to trigger interrupt	Minimum one system clock cycle	Less than a system clock cycle
Waking the device from sleep	From all interrupt sense configurations from sleep modes with the main clock running. Only from BOTHEDGES or LEVEL interrupt sense configuration from sleep modes with the main clock stopped.	From all interrupt sense configurations from all sleep modes
Interrupt 'dead time'	No new interrupt for three cycles after the previous	No limitation
Minimum wake-up pulse length	Value on pad must be kept until the system clock has restarted	No limitation

#### Related Links

[8. AVR CPU](#)

[8.7.3 SREG](#)

#### 16.3.4 Events

All PORT pins are asynchronous event system generators. PORT has as many event generators as there are PORT pins in the device. Each event system output from PORT is the value present on the corresponding pin if the digital input driver is enabled. If a pin input driver is disabled, the corresponding event system output is zero.

PORT has no event inputs.

#### 16.3.5 Sleep Mode Operation

With the exception of interrupts and input synchronization, all pin configurations are independent of the Sleep mode. Peripherals connected to the ports can be affected by Sleep modes, described in the respective peripherals' documentation.

The port peripheral will always use the main clock. Input synchronization will halt when this clock stops.

#### 16.3.6 Synchronization

Not applicable.

#### 16.3.7 Configuration Change Protection

Not applicable.

## 16.4 Register Summary - PORT

Offset	Name	Bit Pos.							
0x00	DIR	7:0							DIR[7:0]
0x01	DIRSET	7:0							DIRSET[7:0]
0x02	DIRCLR	7:0							DIRCLR[7:0]
0x03	DIRTGL	7:0							DIRTGL[7:0]
0x04	OUT	7:0							OUT[7:0]
0x05	OUTSET	7:0							OUTSET[7:0]
0x06	OUTCLR	7:0							OUTCLR[7:0]
0x07	OUTTGL	7:0							OUTTGL[7:0]
0x08	IN	7:0							IN[7:0]
0x09	INTFLAGS	7:0							INT[7:0]
0x0A ... 0x0F	Reserved								
0x10	PIN0CTRL	7:0	INVEN				PULLUPEN		ISC[2:0]
0x11	PIN1CTRL	7:0	INVEN				PULLUPEN		ISC[2:0]
0x12	PIN2CTRL	7:0	INVEN				PULLUPEN		ISC[2:0]
0x13	PIN3CTRL	7:0	INVEN				PULLUPEN		ISC[2:0]
0x14	PIN4CTRL	7:0	INVEN				PULLUPEN		ISC[2:0]
0x15	PIN5CTRL	7:0	INVEN				PULLUPEN		ISC[2:0]
0x16	PIN6CTRL	7:0	INVEN				PULLUPEN		ISC[2:0]
0x17	PIN7CTRL	7:0	INVEN				PULLUPEN		ISC[2:0]

## 16.5 Register Description - Ports

### 16.5.1 Data Direction

**Name:** DIR  
**Offset:** 0x00  
**Reset:** 0x00  
**Property:** -

Bit	7	6	5	4	3	2	1	0
	DIR[7:0]							
Access	R/W	R/W	R/W	R/W	R/W	R/W	R/W	R/W
Reset	0	0	0	0	0	0	0	0

**Bits 7:0 – DIR[7:0]** Data Direction

This bit field selects the data direction for the individual pins n of the port. Writing a '1' to PORT.DIR[n] configures and enables pin n as an output pin.

Writing a '0' to PORT.DIR[n] configures pin n as an input pin. It can be configured by writing to the ISC bit in PORT.PINnCTRL.

### 16.5.2 Data Direction Set

**Name:** DIRSET  
**Offset:** 0x01  
**Reset:** 0x00  
**Property:** -

Bit	7	6	5	4	3	2	1	0
	DIRSET[7:0]							
Access	R/W	R/W	R/W	R/W	R/W	R/W	R/W	R/W
Reset	0	0	0	0	0	0	0	0

**Bits 7:0 – DIRSET[7:0]** Data Direction Set

This bit field can be used instead of a read-modify-write to set individual pins as output. Writing a '1' to DIRSET[n] will set the corresponding PORT.DIR[n] bit.

Reading this bit field will always return the value of PORT.DIR.

### 16.5.3 Data Direction Clear

**Name:** DIRCLR  
**Offset:** 0x02  
**Reset:** 0x00  
**Property:** -

Bit	7	6	5	4	3	2	1	0
	DIRCLR[7:0]							
Access	R/W	R/W	R/W	R/W	R/W	R/W	R/W	R/W
Reset	0	0	0	0	0	0	0	0

**Bits 7:0 – DIRCLR[7:0]** Data Direction Clear

This register can be used instead of a read-modify-write to configure individual pins as input. Writing a '1' to DIRCLR[n] will clear the corresponding bit in PORT.DIR.

Reading this bit field will always return the value of PORT.DIR.

### 16.5.4 Data Direction Toggle

**Name:** DIRTGL  
**Offset:** 0x03  
**Reset:** 0x00  
**Property:** -

Bit	7	6	5	4	3	2	1	0
	DIRTGL[7:0]							
Access	R/W	R/W	R/W	R/W	R/W	R/W	R/W	R/W
Reset	0	0	0	0	0	0	0	0

**Bits 7:0 – DIRTGL[7:0]** Data Direction Toggle

This bit field can be used instead of a read-modify-write to toggle the direction of individual pins.

Writing a '1' to DIRTGL[n] will toggle the corresponding bit in PORT.DIR.

Reading this bit field will always return the value of PORT.DIR.

### 16.5.5 Output Value

**Name:** OUT  
**Offset:** 0x04  
**Reset:** 0x00  
**Property:** -

Bit	7	6	5	4	3	2	1	0
	OUT[7:0]							
Access	R/W	R/W	R/W	R/W	R/W	R/W	R/W	R/W
Reset	0	0	0	0	0	0	0	0

**Bits 7:0 – OUT[7:0] Output Value**

This bit field defines the data output value for the individual pins n of the port.

If OUT[n] is written to '1', pin n is driven high.

If OUT[n] is written to '0', pin n is driven low.

In order to have any effect, the pin direction must be configured as output.



### 16.5.6 Output Value Set

**Name:** OUTSET  
**Offset:** 0x05  
**Reset:** 0x00  
**Property:** -

Bit	7	6	5	4	3	2	1	0
	OUTSET[7:0]							
Access	R/W	R/W	R/W	R/W	R/W	R/W	R/W	R/W
Reset	0	0	0	0	0	0	0	0

**Bits 7:0 – OUTSET[7:0]** Output Value Set

This bit field can be used instead of a read-modify-write to set the output value of individual pins to '1'. Writing a '1' to OUTSET[n] will set the corresponding bit in PORT.OUT.

Reading this bit field will always return the value of PORT.OUT.

### 16.5.7 Output Value Clear

**Name:** OUTCLR  
**Offset:** 0x06  
**Reset:** 0x00  
**Property:** -

Bit	7	6	5	4	3	2	1	0
	OUTCLR[7:0]							
Access	R/W	R/W	R/W	R/W	R/W	R/W	R/W	R/W
Reset	0	0	0	0	0	0	0	0

**Bits 7:0 – OUTCLR[7:0]** Output Value Clear

This register can be used instead of a read-modify-write to clear the output value of individual pins to '0'. Writing a '1' to OUTCLR[n] will clear the corresponding bit in PORT.OUT.

Reading this bit field will always return the value of PORT.OUT.

**16.5.8 Output Value Toggle**

**Name:** OUTTGL  
**Offset:** 0x07  
**Reset:** 0x00  
**Property:** -

Bit	7	6	5	4	3	2	1	0
	OUTTGL[7:0]							
Access	R/W	R/W	R/W	R/W	R/W	R/W	R/W	R/W
Reset	0	0	0	0	0	0	0	0

**Bits 7:0 – OUTTGL[7:0] Output Value Toggle**

This register can be used instead of a read-modify-write to toggle the output value of individual pins. Writing a '1' to OUTTGL[n] will toggle the corresponding bit in PORT.OUT.

Reading this bit field will always return the value of PORT.OUT.

### 16.5.9 Input Value

**Name:** IN  
**Offset:** 0x08  
**Reset:** 0x00  
**Property:** -

Bit	7	6	5	4	3	2	1	0
	IN[7:0]							
Access	R/W	R/W	R/W	R/W	R/W	R/W	R/W	R/W
Reset	0	0	0	0	0	0	0	0

**Bits 7:0 – IN[7:0] Input Value**

This register shows the value present on the pins if the digital input driver is enabled. IN[n] shows the value of pin n of the port. The input is not sampled and cannot be read if the digital input buffers are disabled.

Writing to a bit of PORT.IN will toggle the corresponding bit in PORT.OUT.

**16.5.10 Interrupt Flags**

**Name:** INTFLAGS  
**Offset:** 0x09  
**Reset:** 0x00  
**Property:** -

Bit	7	6	5	4	3	2	1	0
	INT[7:0]							
Access	R/W	R/W	R/W	R/W	R/W	R/W	R/W	R/W
Reset	0	0	0	0	0	0	0	0

**Bits 7:0 – INT[7:0] Interrupt Pin Flag**

The INT Flag is set when a pin change/state matches the pin's input sense configuration. Writing a '1' to a flag's bit location will clear the flag.

For enabling and executing the interrupt, refer to ISC bit description in PORT.PINnCTRL.

### 16.5.11 Pin n Control

**Name:** PINCTRL  
**Offset:** 0x10 + n\*0x01 [n=0..7]  
**Reset:** 0x00  
**Property:** -

Bit	7	6	5	4	3	2	1	0
	INVEN				PULLUPEN	ISC[2:0]		
Access	R/W				R/W	R/W	R/W	R/W
Reset	0				0	0	0	0

#### Bit 7 – INVEN Inverted I/O Enable

Value	Description
0	I/O on pin n not inverted
1	I/O on pin n inverted

#### Bit 3 – PULLUPEN Pullup Enable

Value	Description
0	Pullup disabled for pin n
1	Pullup enabled for pin n

#### Bits 2:0 – ISC[2:0] Input/Sense Configuration

These bits configure the input and sense configuration of pin n. The sense configuration determines how a port interrupt can be triggered. If the input buffer is disabled, the input cannot be read in the IN register.

Value	Name	Description
0x0	INTDISABLE	Interrupt disabled but input buffer enabled
0x1	BOTHEDGES	Sense both edges
0x2	RISING	Sense rising edge
0x3	FALLING	Sense falling edge
0x4	INPUT_DISABLE	Digital input buffer disabled
0x5	LEVEL	Sense low level
other	-	Reserved

## 16.6 Register Summary - VPORT

Offset	Name	Bit Pos.							
0x00	DIR	7:0						DIR[7:0]	
0x01	OUT	7:0						OUT[7:0]	
0x02	IN	7:0						IN[7:0]	
0x03	INTFLAGS	7:0						INT[7:0]	

## 16.7 Register Description - Virtual Ports

### 16.7.1 Data Direction

**Name:** DIR  
**Offset:** 0x00  
**Reset:** 0x00  
**Property:** -

Writing to the Virtual PORT registers has the same effect as writing to the regular registers, but allows for memory-specific instructions, such as bit-manipulation instructions, which are not valid for the extended I/O memory space where the regular PORT registers reside.

Bit	7	6	5	4	3	2	1	0
	DIR[7:0]							
Access	R/W	R/W	R/W	R/W	R/W	R/W	R/W	R/W
Reset	0	0	0	0	0	0	0	0

**Bits 7:0 – DIR[7:0]** Data Direction

This bit field selects the data direction for the individual pins in the port.



### 16.7.2 Output Value

**Name:** OUT  
**Offset:** 0x01  
**Reset:** 0x00  
**Property:** -

Writing to the Virtual PORT registers has the same effect as writing to the regular registers, but allows for memory-specific instructions, such as bit-manipulation instructions, which are not valid for the extended I/O memory space where the regular PORT registers reside.

Bit	7	6	5	4	3	2	1	0
	OUT[7:0]							
Access	R/W	R/W	R/W	R/W	R/W	R/W	R/W	R/W
Reset	0	0	0	0	0	0	0	0

#### **Bits 7:0 – OUT[7:0]** Output Value

This bit field selects the data output value for the individual pins in the port.

### 16.7.3 Input Value

**Name:** IN  
**Offset:** 0x02  
**Reset:** 0x00  
**Property:** -

Writing to the Virtual PORT registers has the same effect as writing to the regular registers, but allows for memory-specific instructions, such as bit-manipulation instructions, which are not valid for the extended I/O memory space where the regular PORT registers reside.

Bit	7	6	5	4	3	2	1	0
	IN[7:0]							
Access	R/W	R/W	R/W	R/W	R/W	R/W	R/W	R/W
Reset	0	0	0	0	0	0	0	0

#### **Bits 7:0 – IN[7:0]** Input Value

This bit field holds the value present on the pins if the digital input buffer is enabled. Writing to a bit of VPORT.IN will toggle the corresponding bit in VPORT.OUT.

### 16.7.4 Interrupt Flag

**Name:** INTFLAGS  
**Offset:** 0x03  
**Reset:** 0x00  
**Property:** -

Writing to the Virtual PORT registers has the same effect as writing to the regular registers, but allows for memory-specific instructions, such as bit-manipulation instructions, which are not valid for the extended I/O memory space where the regular PORT registers reside.

Bit	7	6	5	4	3	2	1	0
	INT[7:0]							
Access	R	R	R	R	R	R	R	R
Reset	0	0	0	0	0	0	0	0

#### **Bits 7:0 – INT[7:0]** Interrupt Pin Flag

The INT flag is set when a pin change/state matches the pin's input sense configuration, and the pin is configured as source for port interrupt.

Writing a '1' to this flag's bit location will clear the flag.

For enabling and executing the interrupt, refer to PORT\_PINnCTRL.ISC.

## 17. BOD - Brown-out Detector

### 17.1 Features

- Brown-out Detection monitors the power supply to avoid operation below a programmable level
- There are three modes:
  - Enabled
  - Sampled
  - Disabled
- Separate selection of mode for Active and Sleep modes
- Voltage Level Monitor (VLM) with Interrupt
- Programmable VLM Level Relative to the BOD Level

### 17.2 Overview

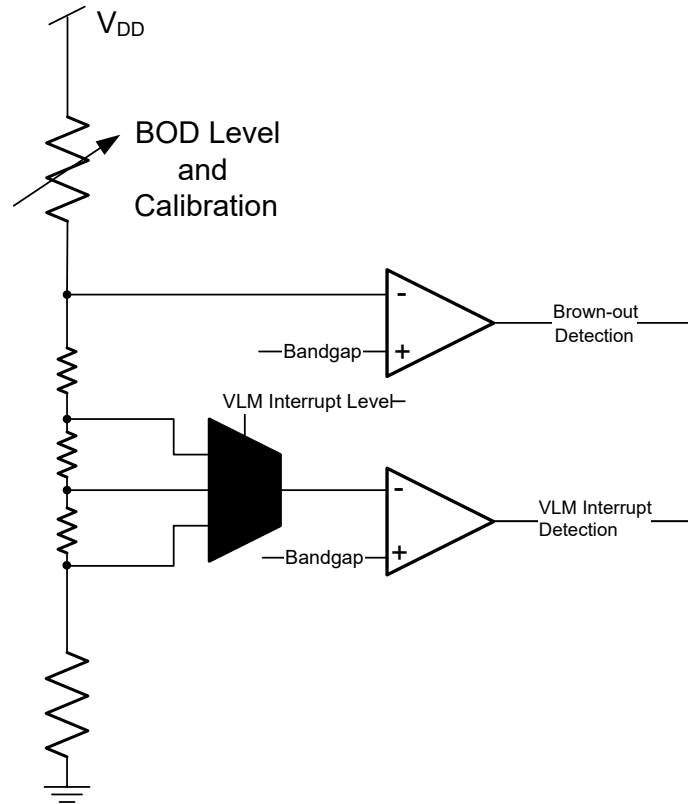
The Brown-out Detector (BOD) peripheral monitors the power supply and compares the voltage with two programmable threshold levels: The brown-out threshold level defines when to generate a Reset. A Voltage Level Monitor (VLM) monitors the power supply and compares it to a threshold higher than the BOD threshold. The VLM can then generate an interrupt request as an "early warning" when the supply voltage is about to drop below the VLM threshold. The VLM threshold level is expressed as a percentage above the BOD threshold level.

The BOD is mainly controlled by fuses. The mode used in Standby Sleep mode and Power-Down Sleep mode can be altered in normal program execution. The VLM part of the BOD is controlled by I/O registers as well.

When activated, the BOD can operate in Enabled mode, where the BOD is continuously active, and in Sampled mode, where the BOD is activated briefly at a given period to check the supply voltage level.

### 17.2.1 Block Diagram

Figure 17-1. BOD Block Diagram



### 17.2.2 System Dependencies

In order to use this peripheral, other parts of the system must be configured correctly, as described below.

Table 17-1. BOD System Dependencies

Dependency	Applicable	Peripheral
Clocks	Yes	CLKCTRL
I/O Lines and Connections	No	-
Interrupts	Yes	CPUINT
Events	Yes	EVSYS
Debug	Yes	UPDI

#### Related Links

- [17.2.2.1 Clocks](#)
- [17.2.2.5 Debug Operation](#)
- [17.2.2.3 Interrupts](#)
- [17.2.2.4 Events](#)

#### 17.2.2.1 Clocks

The BOD uses the 32 KHz oscillator (OSCULP32K) as clock source for CLK\_BOD.

### 17.2.2.2 I/O Lines and Connections

Not applicable.

### 17.2.2.3 Interrupts

Using the interrupts of this peripheral requires the interrupt controller to be configured first.

#### Related Links

[13. CPUINT - CPU Interrupt Controller](#)

[8.7.3 SREG](#)

[17.3.2 Interrupts](#)

### 17.2.2.4 Events

Not applicable.

### 17.2.2.5 Debug Operation

This peripheral is unaffected by entering Debug mode.

The VLM interrupt will not be executed if the CPU is halted in Debug mode.

If the peripheral is configured to require periodical service by the CPU through interrupts or similar, improper operation or data loss may result during halted debugging.

## 17.3 Functional Description

### 17.3.1 Initialization

The BOD settings are loaded from fuses during Reset. The BOD level and operating mode in Active and Idle Sleep mode are set by fuses and cannot be changed by the CPU. The operating mode in Standby and Power-Down Sleep mode is loaded from fuses and can be changed by software.

The Voltage Level Monitor function can be enabled by writing a '1' to the VLM Interrupt Enable bit (VLMIE) in the Interrupt Control register (BOD.INTCTRL). The VLM interrupt is configured by writing the VLM Configuration bits (VLMCFG) in BOD.INTCTRL. An interrupt is requested when the supply voltage crosses the VLM threshold either from above, from below, or from any direction.

The VLM functionality will follow the BOD mode. If the BOD is turned OFF, the VLM will not be enabled, even if the VLMIE is '1'. If the BOD is using Sampled mode, the VLM will also be sampled. When enabling VLM interrupt, the interrupt flag will always be set if VLMCFG equals 0x2 and may be set if VLMCFG is configured to 0x0 or 0x1.

The VLM threshold is defined by writing the VLM Level bits (VLMLVL) in the Control A register (BOD.VLMCTRLA).

If the BOD/VLM is enabled in Sampled mode, only VLMCFG=0x1 (crossing threshold from above) in BOD.INTCTRL will trigger an interrupt.

### 17.3.2 Interrupts

**Table 17-2. Available Interrupt Vectors and Sources**

Offset	Name	Vector Description	Conditions
0x00	VLM	Voltage Level Monitor	Supply voltage crossing the VLM threshold as configured by VLMCFG in BOD.INTCTRL

When an interrupt condition occurs, the corresponding interrupt flag is set in the Interrupt Flags register of the peripheral (*peripheral*.INTFLAGS).

An interrupt source is enabled or disabled by writing to the corresponding enable bit in the peripheral's Interrupt Control register (*peripheral*.INTCTRL).

An interrupt request is generated when the corresponding interrupt source is enabled and the interrupt flag is set. The interrupt request remains active until the interrupt flag is cleared. See the peripheral's INTFLAGS register for details on how to clear interrupt flags.

### Related Links

[8. AVR CPU](#)

[8.7.3 SREG](#)

### 17.3.3 Sleep Mode Operation

There are two separate fuses defining the BOD configuration in different sleep modes; One fuse defines the mode used in Active mode and Idle Sleep mode (ACTIVE in FUSE.BODCFG) and is written to the ACTIVE bits in the Control A register (BOD.CTRLA). The second fuse (SLEEP in FUSE.BODCFG) selects the mode used in Standby Sleep mode and Power-Down Sleep mode and is loaded into the SLEEP bits in the Control A register (BOD.CTRLA).

The operating mode in Active mode and Idle Sleep mode (i.e., ACTIVE in BOD.CTRLA) cannot be altered by software. The operating mode in Standby Sleep mode and Power-Down Sleep mode can be altered by writing to the SLEEP bits in the Control A register (BOD.CTRLA).

When the device is going into Standby Sleep mode or Power-Down Sleep mode, the BOD will change operation mode as defined by SLEEP in BOD.CTRLA. When the device is waking up from Standby or Power-Down Sleep mode, the BOD will operate in the mode defined by the ACTIVE bit field in BOD.CTRLA.

### 17.3.4 Synchronization

Not applicable.

### 17.3.5 Configuration Change Protection

This peripheral has registers that are under Configuration Change Protection (CCP). In order to write to these, a certain key must be written to the CPU.CCP register first, followed by a write access to the protected bits within four CPU instructions.

Attempting to write to a protected register without following the appropriate CCP unlock sequence leaves the protected register unchanged.

The following registers are under CCP:

**Table 17-3. Registers Under Configuration Change Protection**

Register	Key
SLEEP in BOD.CTRLA	IOREG

### Related Links

[8.5.7.1 Sequence for Write Operation to Configuration Change Protected I/O Registers](#)

### 17.4 Register Summary - BOD

Offset	Name	Bit Pos.							
0x00	<a href="#">CTRLA</a>	7:0				SAMPFREQ	ACTIVE[1:0]	SLEEP[1:0]	
0x01	<a href="#">CTRLB</a>	7:0						LVL[2:0]	
0x02	Reserved								
...									
...									
0x07									
0x08	<a href="#">VLMCTRLA</a>	7:0						VLMLVL[1:0]	
0x09	<a href="#">INTCTRL</a>	7:0					VLMCFG[1:0]	VLMIE	
0x0A	<a href="#">INTFLAGS</a>	7:0						VLMIF	
0x0B	<a href="#">STATUS</a>	7:0						VLMS	

### 17.5 Register Description



### 17.5.1 Control A

**Name:** CTRLA  
**Offset:** 0x00  
**Reset:** Loaded from fuse  
**Property:** Configuration Change Protection

	7	6	5	4	3	2	1	0
				SAMPFREQ	ACTIVE[1:0]		SLEEP[1:0]	
Access				R	R	R	R/W	R/W
Reset				x	x	x	x	x

**Bit 4 – SAMPFREQ** Sample Frequency  
 This bit selects the BOD sample frequency.

The Reset value is loaded from the SAMPFREQ bit in FUSE.BODCFG. This bit is under Configuration Change Protection (CCP).

Value	Description
0x0	Sample frequency is 1 kHz
0x1	Sample frequency is 125 Hz

**Bits 3:2 – ACTIVE[1:0]** Active  
 These bits select the BOD operation mode when the device is in Active or Idle mode.

The Reset value is loaded from the ACTIVE bits in FUSE.BODCFG.

Value	Description
0x0	Disabled
0x1	Enabled
0x2	Sampled
0x3	Enabled with wake-up halted until BOD is ready

**Bits 1:0 – SLEEP[1:0]** Sleep  
 These bits select the BOD operation mode when the device is in Standby or Power-Down Sleep mode.  
 The Reset value is loaded from the SLEEP bits in FUSE.BODCFG.  
 These bits are under Configuration Change Protection (CCP).

Value	Description
0x0	Disabled
0x1	Enabled
0x2	Sampled
0x3	Reserved

### 17.5.2 Control B

**Name:** CTRLB  
**Offset:** 0x01  
**Reset:** Loaded from fuse  
**Property:** -

Bit	7	6	5	4	3	2	1	0
	LVL[2:0]							
Access	R	R	R	R	R	R	R	R
Reset	0	0	0	0	0	x	x	x

#### Bits 2:0 – LVL[2:0] BOD Level

These bits select the BOD threshold level.

The Reset value is loaded from the BOD Level bits (LVL) in the BOD Configuration Fuse (FUSE.BODCFG).

Value	Name	Description
0x0	BODLEVEL0	1.8V
0x1	BODLEVEL1	2.15V
0x2	BODLEVEL2	2.60V
0x3	BODLEVEL3	2.95V
0x4	BODLEVEL4	3.30V
0x5	BODLEVEL5	3.70V
0x6	BODLEVEL6	4.00V
0x7	BODLEVEL7	4.30V

### 17.5.3 VLM Control A

**Name:** VLMCTRLA  
**Offset:** 0x08  
**Reset:** 0x00  
**Property:** -

Bit	7	6	5	4	3	2	1	0
							VLMLVL[1:0]	
Access							R/W	R/W
Reset							0	0

**Bits 1:0 – VLMLVL[1:0]** VLM Level

These bits select the VLM threshold relative to the BOD threshold (LVL in BOD.CTRLB).

Value	Description
0x0	VLM threshold 5% above BOD threshold
0x1	VLM threshold 15% above BOD threshold
0x2	VLM threshold 25% above BOD threshold
other	Reserved

### 17.5.4 Interrupt Control

**Name:** INTCTRL  
**Offset:** 0x09  
**Reset:** 0x00  
**Property:** -

	7	6	5	4	3	2	1	0
						VLMCFG[1:0]		VLMIE
Access						R/W	R/W	R/W
Reset						0	0	0

**Bits 2:1 – VLMCFG[1:0]** VLM Configuration

These bits select which incidents will trigger a VLM interrupt.

Value	Description
0x0	Voltage crosses VLM threshold from above
0x1	Voltage crosses VLM threshold from below
0x2	Either direction is triggering an interrupt request
Other	Reserved

**Bit 0 – VLMIE** VLM Interrupt Enable

Writing a '1' to this bit enables the VLM interrupt.

### 17.5.5 VLM Interrupt Flags

**Name:** INTFLAGS  
**Offset:** 0x0A  
**Reset:** 0x00  
**Property:** -

Bit	7	6	5	4	3	2	1	0
								VLMIF
Access								R/W
Reset								0

**Bit 0 – VLMIF** VLM Interrupt Flag

This flag is set when a trigger from the VLM is given, as configured by the VLMCFG bit in the BOD.INTCTRL register. The flag is only updated when the BOD is enabled.

### 17.5.6 VLM Status

**Name:** STATUS  
**Offset:** 0x0B  
**Reset:** 0x00  
**Property:** -

	7	6	5	4	3	2	1	0
Bit								VLMS
Access								R
Reset								0

**Bit 0 – VLMS** VLM Status

This bit is only valid when the BOD is enabled.

Value	Description
0	The voltage is above the VLM threshold level
1	The voltage is below the VLM threshold level

## 18. VREF - Voltage Reference

### 18.1 Features

- Programmable Voltage Reference Sources:
  - One for each ADC peripheral
  - One for each AC and DAC peripheral
- Each Reference Source Supports Five Different Voltages:
  - 0.55V
  - 1.1V
  - 1.5V
  - 2.5V
  - 4.3V

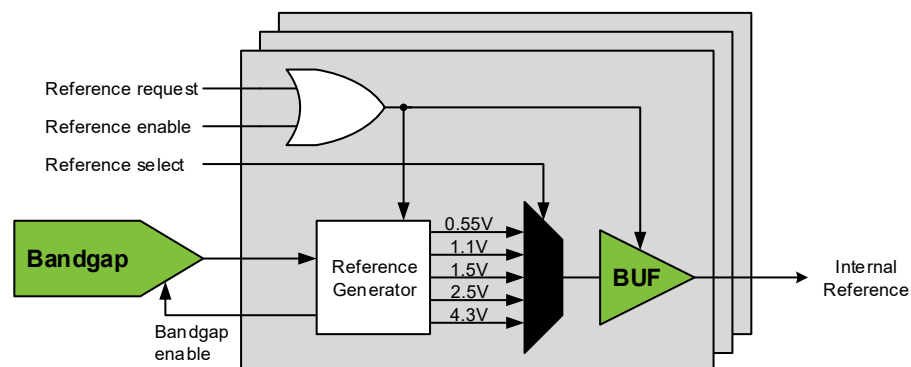
### 18.2 Overview

The Voltage Reference (VREF) peripheral provides control registers for the voltage reference sources used by several peripherals. The user can select the reference voltages for the ADC0 by writing to the ADC0 Reference Select bit field (ADC0REFSEL) in the Control A register (VREF.CTRLA), and for both AC0 and DAC0 by writing to the DAC0 and AC0 Reference Select bit field DAC0REFSEL in VREF.CTRLA.

A voltage reference source is enabled automatically when requested by a peripheral. The user can enable the reference voltage sources (and thus, override the automatic disabling of unused sources) by writing to the respective Force Enable bit (ADC0REFEN, DAC0REFEN) in the Control B register (VREF.CTRLB). This may be desirable to decrease start-up time, at the cost of increased power consumption.

#### 18.2.1 Block Diagram

**Figure 18-1. VREF Block Diagram**



### 18.3 Functional Description

### 18.3.1 Initialization

The default configuration will enable the respective source when the ADC0, AC0, or DAC0 is requesting a reference voltage. The default reference voltages are 0.55V but can be configured by writing to the respective Reference Select bit field (ADC0REFSEL, DAC0REFSEL) in the Control A register (VREF.CTRLA).



### 18.4 Register Summary - VREF

Offset	Name	Bit Pos.								
0x00	<a href="#">CTRLA</a>	7:0		ADC0REFSEL[2:0]				DAC0REFSEL[2:0]		
0x01	<a href="#">CTRLB</a>	7:0			DAC2REFEN	ADC1REFEN	DAC1REFEN		ADC0REFEN	DAC0REFEN

### 18.5 Register Description

### 18.5.1 Control A

**Name:** CTRLA  
**Offset:** 0x00  
**Reset:** 0x00  
**Property:** -

Bit	7	6	5	4	3	2	1	0
	ADC0REFSEL[2:0]				DAC0REFSEL[2:0]			
Access		R/W	R/W	R/W		R/W	R/W	R/W
Reset		0	0	0		0	0	0

**Bits 6:4 – ADC0REFSEL[2:0]** ADC0 Reference Select  
 These bits select the reference voltage for the ADC0.

Value	Description
0x0	0.55V
0x1	1.1V
0x2	2.5V
0x3	4.3V
0x4	1.5V
other	Reserved

**Bits 2:0 – DAC0REFSEL[2:0]** DAC0 and AC0 Reference Select  
 These bits select the reference voltage for the DAC0 and AC0.

Value	Description
0x0	0.55V
0x1	1.1V
0x2	2.5V
0x3	4.3V
0x4	1.5V
other	Reserved

### 18.5.2 Control B

**Name:** CTRLB  
**Offset:** 0x01  
**Reset:** 0x00  
**Property:** -

	7	6	5	4	3	2	1	0
			DAC2REFEN	ADC1REFEN	DAC1REFEN		ADC0REFEN	DAC0REFEN
Access			R/W	R/W	R/W		R/W	R/W
Reset			0	0	0		0	0

**Bit 5 – DAC2REFEN** DAC2 and AC2 Reference Force Enable

Writing a '1' to this bit forces the voltage reference for the DAC2 and AC2 to be running, even if it is not requested.

Writing a '0' to this bit allows to automatic enable/disable the reference source when not requested.

**Bit 4 – ADC1REFEN** ADC1 Reference Force Enable

Writing a '1' to this bit forces the voltage reference for the ADC1 to be running, even if it is not requested.

Writing a '0' to this bit allows to automatic enable/disable the reference source when not requested.

**Note:** Do not force the internal reference enabled (ADCnREFEN=1 in VREF.CTRLB) when the ADC is using the external reference (REFSEL bits in ADC.CTRLA).

**Bit 3 – DAC1REFEN** DAC1 and AC1 Reference Force Enable

Writing a '1' to this bit forces the voltage reference for the DAC1 and AC1 to be running, even if it is not requested.

Writing a '0' to this bit allows to automatic enable/disable the reference source when not requested.

**Bit 1 – ADC0REFEN** ADC0 Reference Force Enable

Writing a '1' to this bit forces the voltage reference for the ADC0 to be running, even if it is not requested.

Writing a '0' to this bit allows automatic enable/disable of the reference source by the peripheral.

**Note:** Do not force the internal reference enabled (ADCnREFEN=1 in VREF.CTRLB) when the ADC is using the external reference (REFSEL bits in ADC.CTRLA).

**Bit 0 – DAC0REFEN** DAC0 and AC0 Reference Force Enable

Writing a '1' to this bit forces the voltage reference for the DAC0 and AC0 to be running, even if it is not requested.

Writing a '0' to this bit allows automatic enable/disable of the reference source by the peripheral.

## 19. WDT - Watchdog Timer

### 19.1 Features

- Issues a System Reset if the Watchdog Timer is not Cleared Before its Time-out Period
- Operating Asynchronously from System Clock Using an Independent Oscillator
- Using the 1 KHz Output of the 32 KHz Ultra Low-Power Oscillator (OSCULP32K)
- 11 Selectable Time-out Periods, from 8 ms to 8s
- Two Operation modes:
  - Normal mode
  - Window mode
- Configuration Lock to Prevent Unwanted Changes
- Closed Period Timer Activation After First WDT Instruction for Easy Setup

### 19.2 Overview

The Watchdog Timer (WDT) is a system function for monitoring correct program operation. It allows the system to recover from situations such as runaway or deadlocked code, by issuing a Reset. When enabled, the WDT is a constantly running timer with a predefined time-out period. If the WDT is not reset within the time-out period, it will issue a system Reset. The WDT is reset by executing the `WDR` (Watchdog Timer Reset) instruction in software.

The WDT has two modes of operation; Normal mode and Window mode. The settings in the Control A register (WDT.CTRLA) determine the mode of operation.

A Window mode defines a time slot or "window" inside the time-out period during which the WDT must be reset. If the WDT is reset outside this window, either too early or too late, a system Reset will be issued. Compared to the Normal mode, the Window mode can catch situations where a code error causes constant `WDR` execution.

When enabled, the WDT will run in Active mode and all Sleep modes. It is asynchronous (i.e., running from a CPU independent clock source). For this reason, it will continue to operate and be able to issue a system Reset even if the main clock fails.

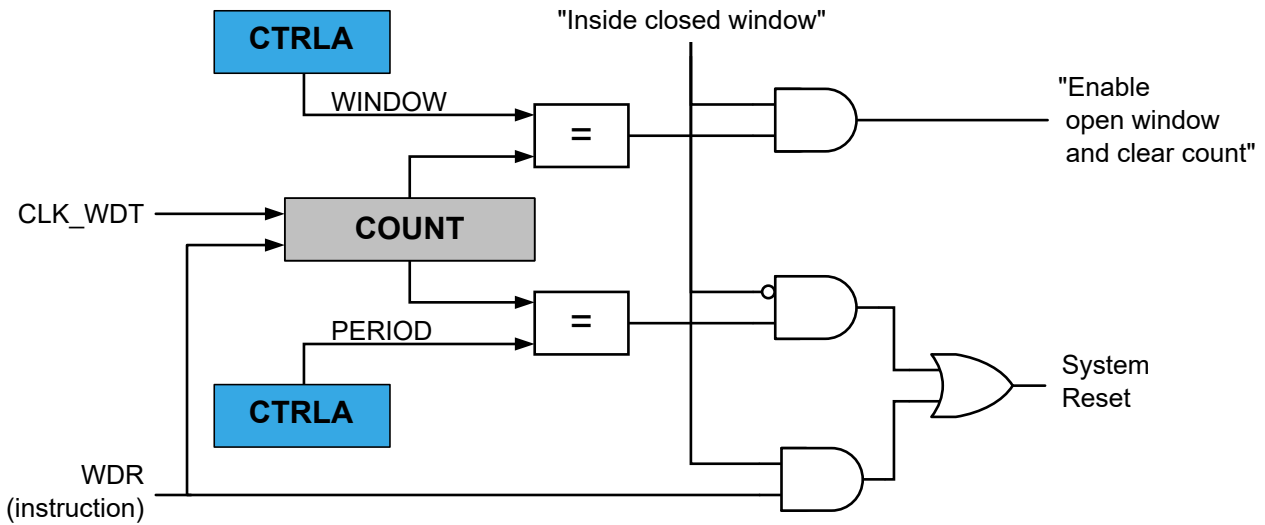
The CCP mechanism ensures that the WDT settings cannot be changed by accident. For increased safety, a configuration for locking the WDT settings is available.

#### Related Links

[8.5.7 Configuration Change Protection \(CCP\)](#)

### 19.2.1 Block Diagram

Figure 19-1. WDT Block Diagram



### 19.2.2 Signal Description

Not applicable.

### 19.2.3 System Dependencies

In order to use this peripheral, other parts of the system must be configured correctly, as described below.

Table 19-1. WDT System Dependencies

Dependency	Applicable	Peripheral
Clocks	Yes	CLKCTRL
I/O Lines and Connections	No	-
Interrupts	No	-
Events	No	-
Debug	Yes	UPDI

#### Related Links

[19.2.3.1 Clocks](#)

[19.2.3.5 Debug Operation](#)

#### 19.2.3.1 Clocks

A 1 KHz Oscillator Clock (CLK\_WDT\_OSC) is sourced from the internal Ultra Low-Power Oscillator, OSCULP32K. Due to the ultra low-power design, the oscillator is not very accurate, and so the exact time-out period may vary from device to device. This variation must be kept in mind when designing software that uses the WDT to ensure that the time-out periods used are valid for all devices.

The Counter Clock CLK\_WDT\_OSC is asynchronous to the system clock. Due to this asynchronicity, writing to the WDT Control register will require synchronization between the clock domains.

#### 19.2.3.2 I/O Lines and Connections

Not applicable.

### 19.2.3.3 Interrupts

Not applicable.

### 19.2.3.4 Events

Not applicable.

### 19.2.3.5 Debug Operation

When run-time debugging, this peripheral will continue normal operation. Halting the CPU in Debugging mode will halt normal operation of the peripheral.

When halting the CPU in Debug mode, the WDT counter is reset.

When starting the CPU again and the WDT is operating in Window mode, the first closed window time-out period will be disabled, and a Normal mode time-out period is executed.

#### Related Links

[19.3.2.2 Window Mode](#)

## 19.3 Functional Description

### 19.3.1 Initialization

- The WDT is enabled when a non-zero value is written to the Period bits (PERIOD) in the Control A register (WDT.CTRLA).
- Optional: Write a non-zero value to the Window bits (WINDOW) in WDT.CTRLA to enable Window mode operation.

All bits in the Control A register and the Lock bit (LOCK) in the STATUS register (WDT.STATUS) are write-protected by the Configuration Change Protection mechanism.

The Reset value of WDT.CTRLA is defined by a fuse (FUSE.WDTCFG), so the WDT can be enabled at boot time. If this is the case, the LOCK bit in WDT.STATUS is set at boot time.

#### Related Links

[19.4 Register Summary - WDT](#)

### 19.3.2 Operation

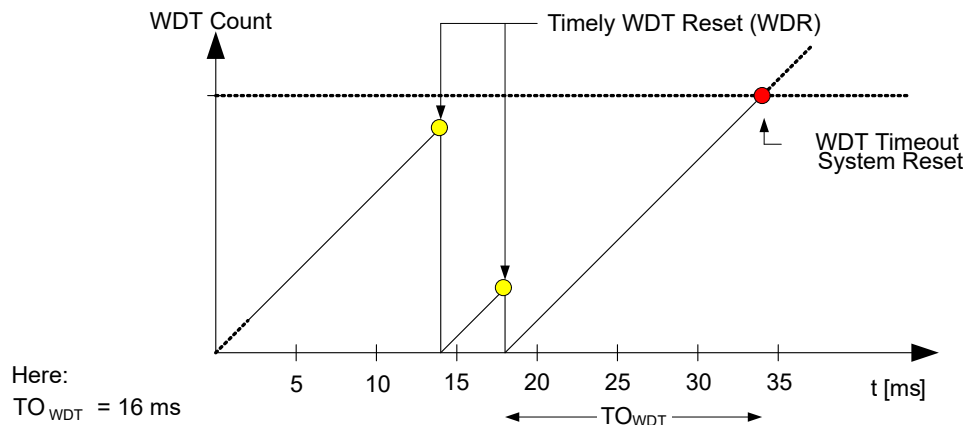
#### 19.3.2.1 Normal Mode

In Normal mode operation, a single time-out period is set for the WDT. If the WDT is not reset from software using the `WDR` any time before the time-out occurs, the WDT will issue a system Reset.

A new WDT time-out period will be started each time the WDT is reset by `WDR`.

There are 11 possible WDT time-out periods ( $TO_{WDT}$ ), selectable from 8 ms to 8s by writing to the Period bit field (PERIOD) in the Control A register (WDT.CTRLA).

**Figure 19-2. Normal Mode Operation**



Normal mode is enabled as long as the WINDOW bit field in the Control A register (WDT.CTRLA) is 0x0.

**Related Links**

[19.4 Register Summary - WDT](#)

**19.3.2.2 Window Mode**

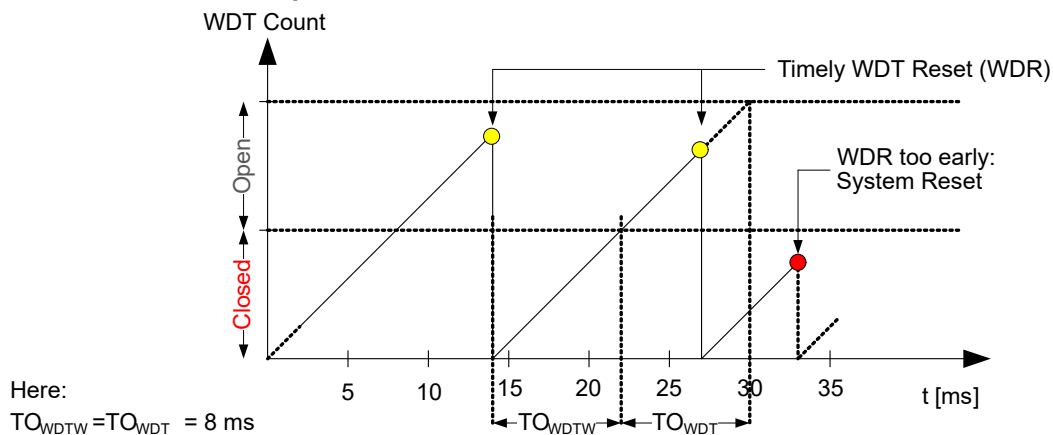
In Window mode operation, the WDT uses two different time-out periods; a closed Window Time-out period ( $TO_{WDTW}$ ) and the normal time-out period ( $TO_{WDT}$ ):

- The closed window time-out period defines a duration from 8 ms to 8s where the WDT cannot be reset. If the WDT is reset during this period, the WDT will issue a system Reset.
- The normal WDT time-out period, which is also 8 ms to 8s, defines the duration of the open period during which the WDT can (and should) be reset. The open period will always follow the closed period, so the total duration of the time-out period is the sum of the closed window and the open window time-out periods.

When enabling Window mode or when going out of Debug mode, the first closed period is activated after the first WDR instruction.

If a second WDR is issued while a previous WDR is being synchronized, the second one will be ignored.

**Figure 19-3. Window Mode Operation**



The Window mode is enabled by writing a non-zero value to the WINDOW bit field in the Control A register (WDT.CTRLA), and disabled by writing WINDOW=0x0.

### 19.3.2.3 Configuration Protection and Lock

The WDT provides two security mechanisms to avoid unintentional changes to the WDT settings:

The first mechanism is the Configuration Change Protection mechanism, employing a timed write procedure for changing the WDT control registers.

The second mechanism locks the configuration by writing a '1' to the LOCK bit in the STATUS register (WDT.STATUS). When this bit is '1', the Control A register (WDT.CTRLA) cannot be changed. Consequently, the WDT cannot be disabled from software.

LOCK in WDT.STATUS can only be written to '1'. It can only be cleared in Debug mode.

If the WDT configuration is loaded from fuses, LOCK is automatically set in WDT.STATUS.

#### Related Links

[8.5.7 Configuration Change Protection \(CCP\)](#)

### 19.3.3 Events

Not applicable.

### 19.3.4 Interrupts

Not applicable.

### 19.3.5 Sleep Mode Operation

The WDT will continue to operate in any sleep mode where the source clock is active.

### 19.3.6 Synchronization

Due to asynchronicity between the main clock domain and the peripheral clock domain, the Control A register (WDT.CTRLA) is synchronized when written. The Synchronization Busy flag (SYNCBUSY) in the STATUS register (WDT.STATUS) indicates if there is an ongoing synchronization.

Writing to WDT.CTRLA while SYNCBUSY=1 is not allowed.

The following registers are synchronized when written:

- PERIOD bits in Control A register (WDT.CTRLA)
- Window Period bits (WINDOW) in WDT.CTRLA

The `WDR` instruction will need two to three cycles of the WDT clock in order to be synchronized. Issuing a new `WDR` instruction while a `WDR` instruction is being synchronized will be ignored.

### 19.3.7 Configuration Change Protection

This peripheral has registers that are under Configuration Change Protection (CCP). In order to write to these, a certain key must be written to the CPU.CCP register first, followed by a write access to the protected bits within four CPU instructions.

Attempting to write to a protected register without following the appropriate CCP unlock sequence leaves the protected register unchanged.

The following registers are under CCP:



**Table 19-2. WDT - Registers Under Configuration Change Protection**

Register	Key
WDT.CTRLA	IOREG
LOCK bit in WDT.STATUS	IOREG

List of bits/registers protected by CCP:

- Period bits in Control A register (CTRLA.PERIOD)
- Window Period bits in Control A register (CTRLA.WINDOW)
- LOCK bit in STATUS register (STATUS.LOCK)

**Related Links**

[8.5.7 Configuration Change Protection \(CCP\)](#)

[8.5.7.1 Sequence for Write Operation to Configuration Change Protected I/O Registers](#)

[8.7.1 CCP](#)

## 19.4 Register Summary - WDT

Offset	Name	Bit Pos.								
0x00	<a href="#">CTRLA</a>	7:0	WINDOW[3:0]				PERIOD[3:0]			
0x01	<a href="#">STATUS</a>	7:0	LOCK						SYNCBUSY	

## 19.5 Register Description

### 19.5.1 Control A

**Name:** CTRLA  
**Offset:** 0x00  
**Reset:** From FUSE.WDTCFG  
**Property:** Configuration Change Protection

Bit	7	6	5	4	3	2	1	0
	WINDOW[3:0]				PERIOD[3:0]			
Access	R/W	R/W	R/W	R/W	R/W	R/W	R/W	R/W
Reset	x	x	x	x	x	x	x	x

#### Bits 7:4 – WINDOW[3:0] Window

Writing a non-zero value to these bits enables the Window mode, and selects the duration of the closed period accordingly.

The bits are optionally lock-protected:

- If LOCK bit in WDT.STATUS is '1', all bits are change-protected (Access = R)
- If LOCK bit in WDT.STATUS is '0', all bits can be changed (Access = R/W)

Value	Name	Description
0x0	OFF	-
0x1	8CLK	0.008s
0x2	16CLK	0.016s
0x3	32CLK	0.032s
0x4	64CLK	0.064s
0x5	128CLK	0.128s
0x6	256CLK	0.256s
0x7	512CLK	0.512s
0x8	1KCLK	1.024s
0x9	2KCLK	2.048s
0xA	4KCLK	4.096s
0xB	8KCLK	8.192s
other	-	Reserved

#### Bits 3:0 – PERIOD[3:0] Period

Writing a non-zero value to this bit enables the WDT, and selects the time-out period in Normal mode accordingly. In Window mode, these bits select the duration of the open window.

The bits are optionally lock-protected:

- If LOCK in WDT.STATUS is '1', all bits are change-protected (Access = R)
- If LOCK in WDT.STATUS is '0', all bits can be changed (Access = R/W)

Value	Name	Description
0x0	OFF	-
0x1	8CLK	0.008s
0x2	16CLK	0.016s
0x3	32CLK	0.032s

# ATtiny1614

## WDT - Watchdog Timer

Value	Name	Description
0x4	64CLK	0.064s
0x5	128CLK	0.128s
0x6	256CLK	0.256s
0x7	512CLK	0.512s
0x8	1KCLK	1.0s
0x9	2KCLK	2.0s
0xA	4KCLK	4.1s
0xB	8KCLK	8.2s
other	-	Reserved

### 19.5.2 Status

**Name:** STATUS  
**Offset:** 0x01  
**Reset:** 0x00  
**Property:** Configuration Change Protection

	Bit	7	6	5	4	3	2	1	0
		LOCK							SYNCBUSY
Access		R/W							R
Reset		0							0

#### Bit 7 – LOCK Lock

Writing this bit to '1' write-protects the WDT.CTRLA register.

It is only possible to write this bit to '1'. This bit can be cleared in Debug mode only.

If the PERIOD bits in WDT.CTRLA are different from zero after boot code, the lock will automatically be set.

This bit is under CCP.

#### Bit 0 – SYNCBUSY Synchronization Busy

This bit is set after writing to the WDT.CTRLA register while the data is being synchronized from the system clock domain to the WDT clock domain.

This bit is cleared by the system after the synchronization is finished.

This bit is not under CCP.

#### Related Links

[19.3.6 Synchronization](#)

[19.3.7 Configuration Change Protection](#)

## **20. TCA - 16-bit Timer/Counter Type A**

### **20.1 Features**

- 16-Bit Timer/Counter
- Three Compare Channels
- Double-Buffered Timer Period Setting
- Double-Buffered Compare Channels
- Waveform Generation:
  - Frequency generation
  - Single-slope PWM (pulse-width modulation)
  - Dual-slope PWM
- Count on Event
- Timer Overflow Interrupts/Events
- One Compare Match per Compare Channel
- Two 8-Bit Timer/Counters in Split Mode

### **20.2 Overview**

The flexible 16-bit PWM Timer/Counter type A (TCA) provides accurate program execution timing, frequency and waveform generation, and command execution.

A TCA consists of a base counter and a set of compare channels. The base counter can be used to count clock cycles or events or let events control how it counts clock cycles. It has direction control and period setting that can be used for timing. The compare channels can be used together with the base counter to do compare match control, frequency generation, and pulse-width waveform modulation.

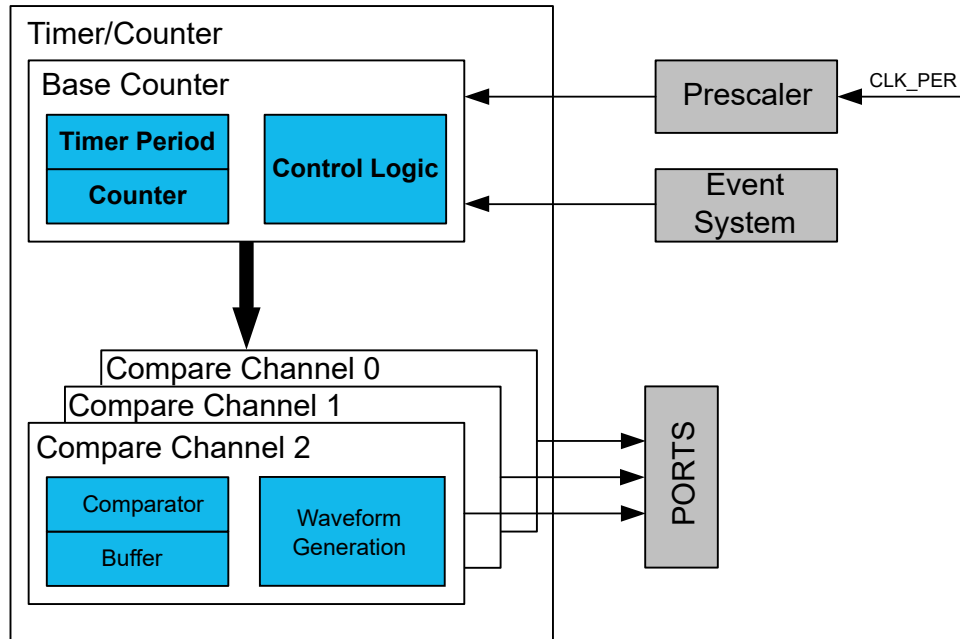
Depending on the mode of operation, the counter is cleared, reloaded, incremented, or decremented at each timer/counter clock or event input.

A timer/counter can be clocked and timed from the peripheral clock with optional prescaling or from the event system. The event system can also be used for direction control or to synchronize operations.

By default, the TCA is a 16-bit timer/counter. The timer/counter has a Split mode feature that splits it into two 8-bit timer/counters with three compare channels each. In Split mode, each compare channel only supports single-slope PWM waveform generation.

A block diagram of the 16-bit timer/counter with closely related peripheral modules (in grey) is shown in the figure below.

Figure 20-1. 16-bit Timer/Counter and Closely Related Peripherals

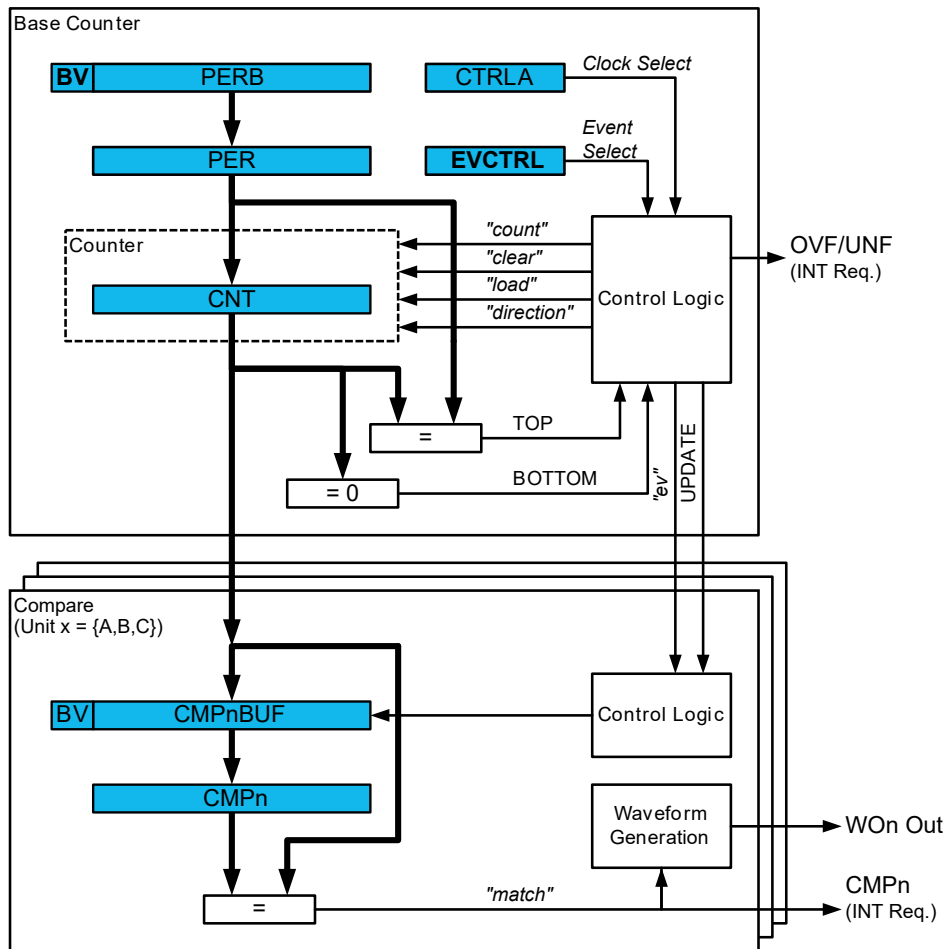


This device provides one instance of the TCA peripheral, TCA0.

### 20.2.1 Block Diagram

The figure below shows a detailed block diagram of the timer/counter.

**Figure 20-2. Timer/Counter Block Diagram**



The counter register (TCA<sub>n</sub>.CNT), period registers with buffer (TCA<sub>n</sub>.PER and TCA<sub>n</sub>.PERBUF), and compare registers with buffers (TCA<sub>n</sub>.CMP<sub>x</sub> and TCA<sub>n</sub>.CMPBUF<sub>x</sub>) are 16-bit registers. All buffer registers have a buffer valid (BV) flag that indicates when the buffer contains a new value.

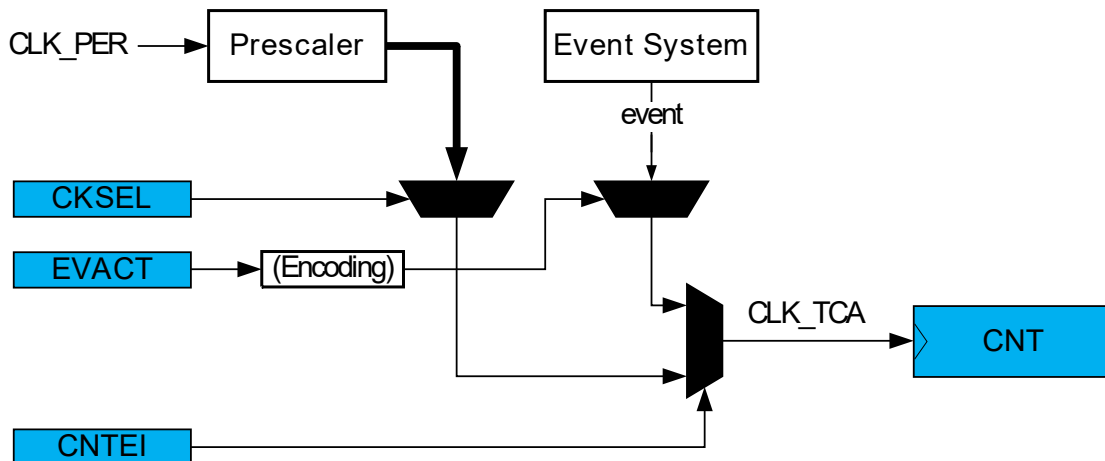
During normal operation, the counter value is continuously compared to zero and the period (PER) value to determine whether the counter has reached TOP or BOTTOM.

The counter value is also compared to the TCA<sub>n</sub>.CMP<sub>x</sub> registers. These comparisons can be used to generate interrupt requests. The Waveform Generator modes use these comparisons to set the waveform period or pulse-width.

A prescaled peripheral clock and events from the event system can be used to control the counter.



**Figure 20-3. Timer/Counter Clock Logic**



### 20.2.2 Signal Description

Signal	Description	Type
WO[2:0]	Digital output	Waveform output
WO[5:3]	Digital output	Waveform output - Split Mode only

### 20.2.3 System Dependencies

In order to use this peripheral, other parts of the system must be configured correctly, as described below.

**Table 20-1. TCA System Dependencies**

Dependency	Applicable	Peripheral
Clocks	Yes	CLKCTRL
I/O Lines and Connections	Yes	WO[5:0]
Interrupts	Yes	CPUINT
Events	Yes	EVSYS
Debug	Yes	UPDI

#### Related Links

- [20.2.3.1 Clocks](#)
- [20.2.3.5 Debug Operation](#)
- [20.2.3.3 Interrupts](#)
- [20.2.3.4 Events](#)

#### 20.2.3.1 Clocks

This peripheral uses the system clock CLK\_PER and has its own prescaler.

#### Related Links

- [10. CLKCTRL - Clock Controller](#)

#### 20.2.3.2 I/O Lines and Connections

Using the I/O lines of the peripheral requires configuration of the I/O pins.

### Related Links

- [5. I/O Multiplexing and Considerations](#)
- [16. PORT - I/O Pin Configuration](#)

### 20.2.3.3 Interrupts

Using the interrupts of this peripheral requires the interrupt controller to be configured first.

### Related Links

- [13. CPUINT - CPU Interrupt Controller](#)
- [8.7.3 SREG](#)
- [20.3.5 Interrupts](#)

### 20.2.3.4 Events

The events of this peripheral are connected to the Event System.

### Related Links

- [14. EVSYS - Event System](#)

### 20.2.3.5 Debug Operation

When run-time debugging, this peripheral will continue normal operation. Halting the CPU in Debugging mode will halt normal operation of the peripheral.

This peripheral can be forced to operate with halted CPU by writing a '1' to the Debug Run bit (DBGRUN) in the Debug Control register of the peripheral (*peripheral.DBGCTRL*).

### Related Links

- [33. UPDI - Unified Program and Debug Interface](#)

## 20.3 Functional Description

### 20.3.1 Definitions

The following definitions are used throughout the documentation:

**Table 20-2. Timer/Counter Definitions**

Name	Description
BOTTOM	The counter reaches BOTTOM when it becomes zero.
MAX	The counter reaches MAXimum when it becomes all ones.
TOP	The counter reaches TOP when it becomes equal to the highest value in the count sequence.
UPDATE	The update condition is met when the timer/counter reaches BOTTOM or TOP, depending on the Waveform Generator mode.
CNT	Counter register value.
CMP	Compare register value.

In general, the term timer is used when the timer/counter is counting periodic clock ticks. The term counter is used when the input signal has sporadic or irregular ticks.

### 20.3.2 Initialization

To start using the timer/counter in a basic mode, follow these steps:

- Write a TOP value to the Period register (TCA<sub>n</sub>.PER)
- Enable the peripheral by writing a '1' to the ENABLE bit in the Control A register (TCA<sub>n</sub>.CTRLA). The counter will start counting clock ticks according to the prescaler setting in the Clock Select bit field (CLKSEL) in TCA<sub>n</sub>.CTRLA.
- Optional: By writing a '1' to the Enable Count on Event Input bit (CNTEI) in the Event Control register (TCA<sub>n</sub>.EVCTRL), event inputs are counted instead of clock ticks.
- The counter value can be read from the Counter bit field (CNT) in the Counter register (TCA<sub>n</sub>.CNT).

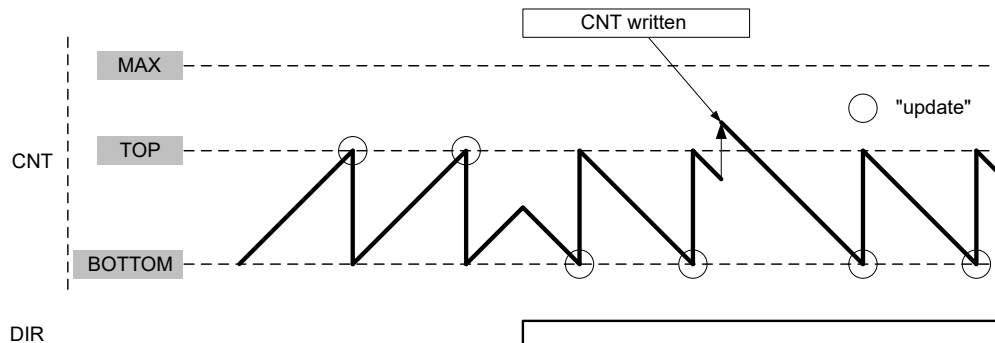
### 20.3.3 Operation

#### 20.3.3.1 Normal Operation

In normal operation, the counter is counting clock ticks in the direction selected by the Direction bit (DIR) in the Control E register (TCA<sub>n</sub>.CTRLA), until it reaches TOP or BOTTOM. The clock ticks are from the peripheral clock CLK\_PER, optionally prescaled, depending on the Clock Select bit field (CLKSEL) in the Control A register (TCA<sub>n</sub>.CTRLA).

When up-counting and TOP are reached, the counter will wrap to zero at the next clock tick. When down-counting, the counter is reloaded with the Period register value (TCA<sub>n</sub>.PER) when BOTTOM is reached.

**Figure 20-4. Normal Operation**



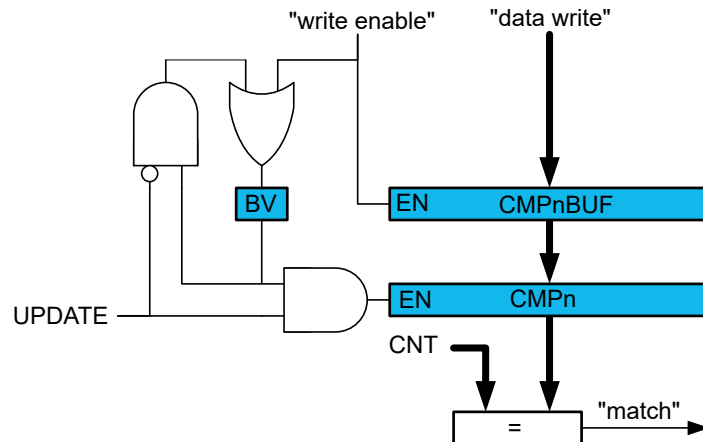
It is possible to change the counter value in the Counter register (TCA<sub>n</sub>.CNT) when the counter is running. The write access to TCA<sub>n</sub>.CNT has higher priority than count, clear, or reload, and will be immediate. The direction of the counter can also be changed during normal operation by writing to DIR in TCA<sub>n</sub>.CTRLA.

#### 20.3.3.2 Double Buffering

The Period register value (TCA<sub>n</sub>.PER) and the Compare n register values (TCA<sub>n</sub>.CMP<sub>n</sub>) are all double-buffered (TCA<sub>n</sub>.PERBUF and TCA<sub>n</sub>.CMP<sub>n</sub>BUF).

Each buffer register has a Buffer Valid flag (PERBV, CMP<sub>n</sub>BV) in the Control F register (TCA<sub>n</sub>.CTRLF), which indicates that the buffer register contains a valid, i.e. new, value that can be copied into the corresponding Period or Compare register. When the Period register and Compare n registers are used for a compare operation, the BV flag is set when data is written to the buffer register and cleared on an UPDATE condition. This is shown for a Compare register (CMP<sub>n</sub>) below.

**Figure 20-5. Period and Compare Double Buffering**



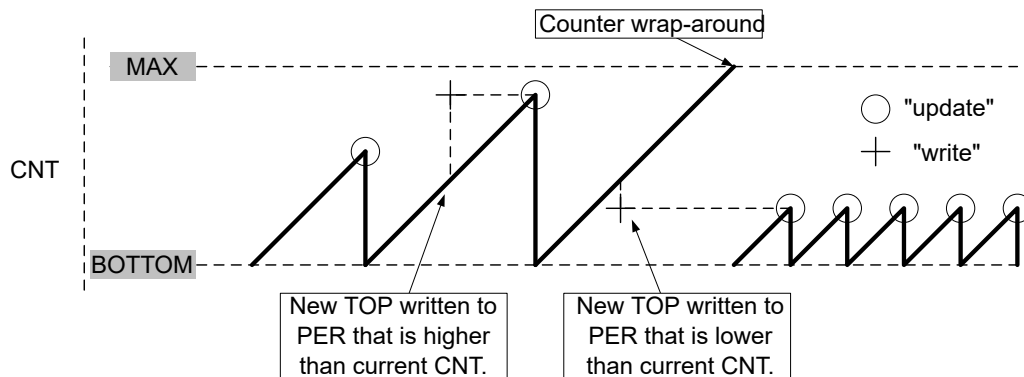
Both the TCA<sub>n</sub>.CMP<sub>n</sub> and TCA<sub>n</sub>.CMP<sub>n</sub>BUF registers are available as I/O registers. This allows initialization and bypassing of the buffer register and the double buffering function.

### 20.3.3.3 Changing the Period

The Counter period is changed by writing a new TOP value to the Period register (TCA<sub>n</sub>.PER).

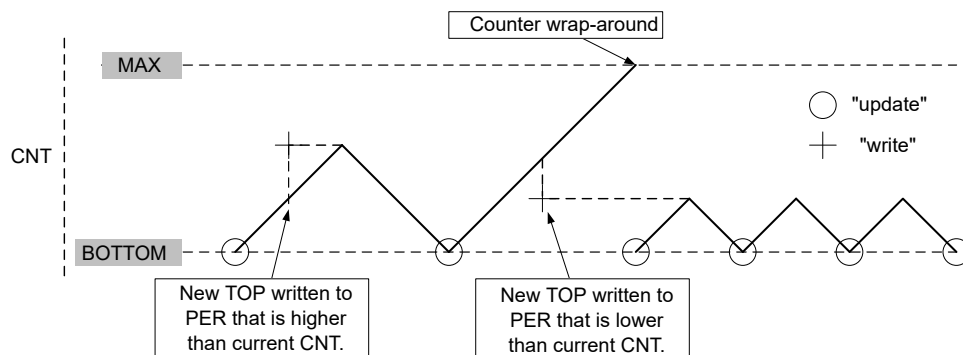
**No Buffering:** If double buffering is not used, any period update is immediate.

**Figure 20-6. Changing the Period Without Buffering**



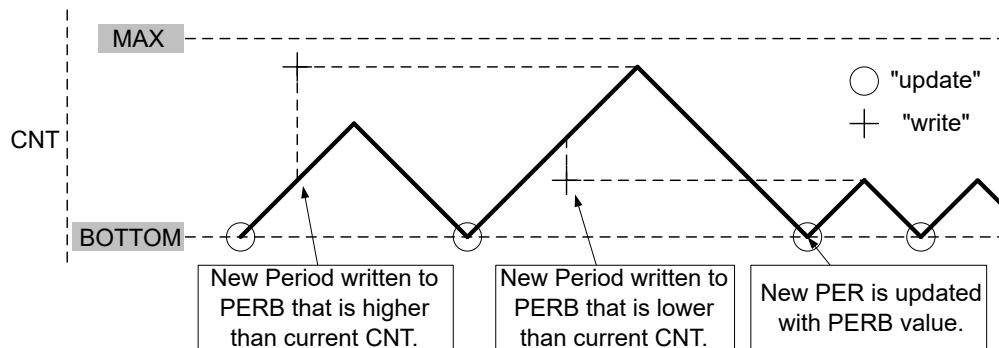
A counter wrap-around can occur in any mode of operation when up-counting without buffering. This is due to the fact that the TCA<sub>n</sub>.CNT and TCA<sub>n</sub>.PER registers are continuously compared: if a new TOP value is written to TCA<sub>n</sub>.PER that is lower than the current TCA<sub>n</sub>.CNT, the counter will wrap first, before a compare match happens.

**Figure 20-7. Unbuffered Dual-Slope Operation**



**With Buffering:** When double buffering is used, the buffer can be written at any time and still maintain correct operation. The TCA<sub>n</sub>.PER is always updated on the UPDATE condition, as shown for dual-slope operation in the figure below. This prevents wrap-around and the generation of odd waveforms.

**Figure 20-8. Changing the Period Using Buffering**



### 20.3.3.4 Compare Channel

Each Compare Channel *n* continuously compares the counter value (TCA<sub>n</sub>.CNT) with the Compare *n* register (TCA<sub>n</sub>.CMP<sub>n</sub>). If TCA<sub>n</sub>.CNT equals TCA<sub>n</sub>.CMP<sub>n</sub>, the comparator *n* signals a match. The match will set the Compare Channel's Interrupt flag at the next timer clock cycle, and the optional interrupt is generated.

The Compare *n* Buffer register (TCA<sub>n</sub>.CMP<sub>n</sub>BUF) provides double buffer capability equivalent to that for the period buffer. The double buffering synchronizes the update of the TCA<sub>n</sub>.CMP<sub>n</sub> register with the buffer value to either the TOP or BOTTOM of the counting sequence, according to the UPDATE condition. The synchronization prevents the occurrence of odd-length, non-symmetrical pulses for glitch-free output.

#### 20.3.3.4.1 Waveform Generation

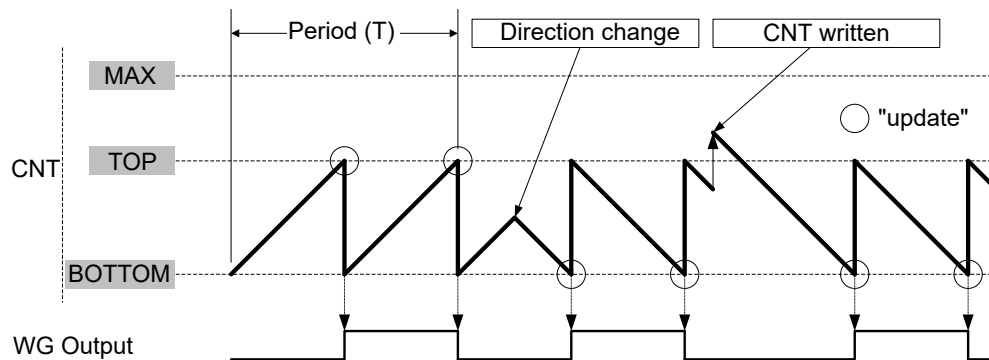
The compare channels can be used for waveform generation on the corresponding port pins. To make the waveform visible on the connected port pin, the following requirements must be met:

1. A Waveform Generation mode must be selected by writing the WGMODE bit field in TCA<sub>n</sub>.CTRLB.
2. The TCA is counting clock ticks, not events (CNTEI=0 in TCA<sub>n</sub>.EVCTRL).
3. The compare channels used must be enabled (CMP<sub>n</sub>EN=1 in TCA<sub>n</sub>.CTRLB). This will override the corresponding port pin output register. An alternative pin can be selected by writing to the respective TCA Waveform Output *n* bit (TCA0<sub>n</sub>) in the Control C register of the Port Multiplexer (PORTMUX.CTRLA).
4. The direction for the associated port pin *n* must be configured as an output (PORT<sub>x</sub>.DIR[*n*]=1).
5. Optional: Enable inverted waveform output for the associated port pin *n* (INVEN=1 in PORT<sub>x</sub>.PIN<sub>n</sub>).

#### 20.3.3.4.2 Frequency (FRQ) Waveform Generation

For frequency generation, the period time (*T*) is controlled by a TCA<sub>n</sub>.CMP<sub>n</sub> register instead of the Period register (TCA<sub>n</sub>.PER). The waveform generation output WG is toggled on each compare match between the TCA<sub>n</sub>.CNT and TCA<sub>n</sub>.CMP<sub>n</sub> registers.

**Figure 20-9. Frequency Waveform Generation**



The waveform frequency ( $f_{FRQ}$ ) is defined by the following equation:

$$f_{FRQ} = \frac{f_{CLK\_PER}}{2N(CMPn+1)}$$

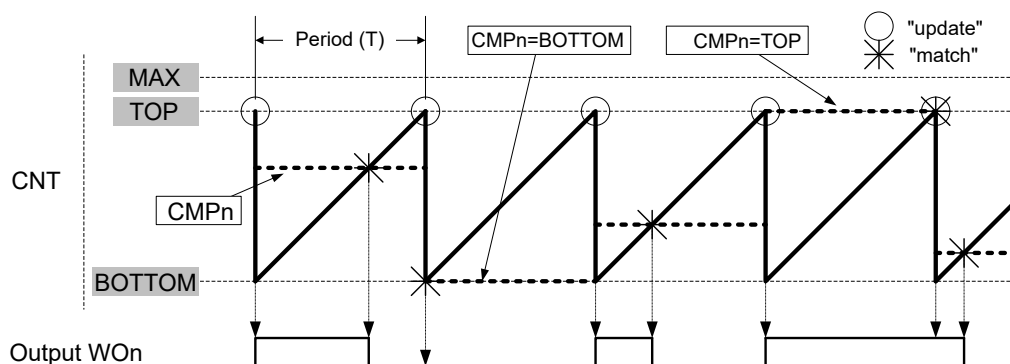
where  $N$  represents the prescaler divider used (CLKSEL in TCA $n$ .CTRLA),  $CMPn$  is the value of the TCA $n$ .CMP $n$  register, and  $f_{CLK\_PER}$  is the system clock for the peripherals.

The maximum frequency of the waveform generated is half of the peripheral clock frequency ( $f_{CLK\_PER}/2$ ) when TCA $n$ .CMP $n$  is written to zero (0x0000) and no prescaling is used ( $N=1$ , CLKSEL=0x0 in TCA $n$ .CTRLA).

### 20.3.3.4.3 Single-Slope PWM Generation

For single-slope Pulse-Width Modulation (PWM) generation, the period ( $T$ ) is controlled by TCA $n$ .PER, while the values of TCA $n$ .CMP $n$  control the duty-cycle of the WG output. The figure below shows how the counter counts from BOTTOM to TOP and then restarts from BOTTOM. The waveform generator (WO) output is set at TOP and cleared on the compare match between the TCA $n$ .CNT and TCA $n$ .CMP $n$  registers.

**Figure 20-10. Single-Slope Pulse-Width Modulation**



The TCA $n$ .PER register defines the PWM resolution. The minimum resolution is 2 bits (TCA.PER=0x0003), and the maximum resolution is 16 bits (TCA.PER=MAX).

The following equation calculates the exact resolution for single-slope PWM ( $R_{PWM\_SS}$ ):

$$R_{PWM\_SS} = \frac{\log(PER+1)}{\log(2)}$$

The single-slope PWM frequency ( $f_{PWM\_SS}$ ) depends on the period setting (TCA\_PER), the system's peripheral clock frequency  $f_{CLK\_PER}$ , and the TCA prescaler (CLKSEL in TCA $n$ .CTRLA). It is calculated by the following equation where  $N$  represents the prescaler divider used:

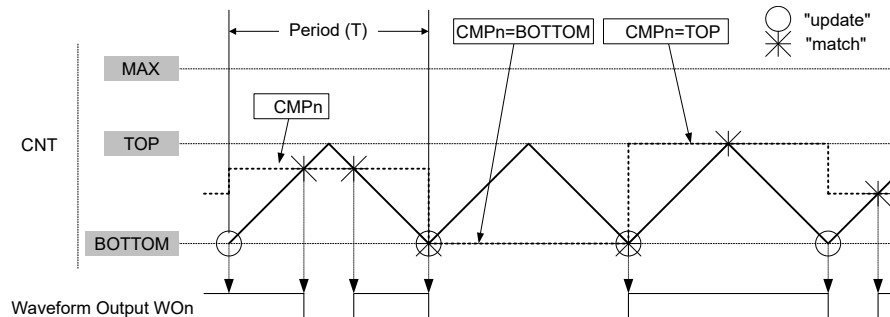
$$f_{PWM\_SS} = \frac{f_{CLK\_PER}}{N(PER+1)}$$

### 20.3.3.4.4 Dual-Slope PWM

For dual-slope PWM generation, the period (T) is controlled by TCA<sub>n</sub>.PER, while the values of TCA<sub>n</sub>.CMP<sub>n</sub> control the duty-cycle of the WG output.

The figure below shows how for dual-slope PWM the counter counts repeatedly from BOTTOM to TOP and then from TOP to BOTTOM. The waveform generator output is set on BOTTOM, cleared on compare match when up-counting, and set on compare match when down-counting.

**Figure 20-11. Dual-Slope Pulse-Width Modulation**



Using dual-slope PWM results in a lower maximum operation frequency compared to the single-slope PWM operation.

The period register (TCA<sub>n</sub>.PER) defines the PWM resolution. The minimum resolution is 2 bits (TCA<sub>n</sub>.PER=0x0003), and the maximum resolution is 16 bits (TCA<sub>n</sub>.PER=MAX).

The following equation calculates the exact resolution for dual-slope PWM ( $R_{PWM\_DS}$ ):

$$R_{PWM\_DS} = \frac{\log(PER+1)}{\log(2)}$$

The PWM frequency depends on the period setting (TCA<sub>n</sub>.PER), the peripheral clock frequency ( $f_{CLK\_PER}$ ), and the prescaler divider used (CLKSEL in TCA<sub>n</sub>.CTRLA). It is calculated by the following equation:

$$f_{PWM\_DS} = \frac{f_{CLK\_PER}}{2N \cdot PER}$$

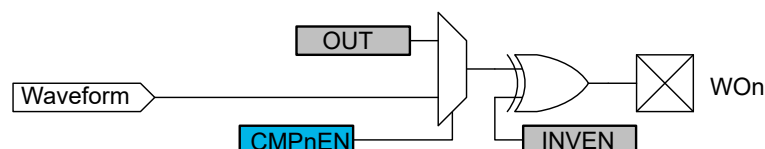
$N$  represents the prescaler divider used.

### 20.3.3.4.5 Port Override for Waveform Generation

To make the waveform generation available on the port pins, the corresponding port pin direction must be set as output (PORT<sub>x</sub>.DIR[n]=1). The TCA will override the port pin values when the compare channel is enabled (CMP<sub>n</sub>EN=1 in TCA<sub>n</sub>.CTRLB) and a Waveform Generation mode is selected.

The figure below shows the port override for TCA. The timer/counter compare channel will override the port pin output value (OUT) on the corresponding port pin. Enabling inverted I/O on the port pin (INVEN=1 in PORT.PIN<sub>n</sub>) inverts the corresponding WG output.

**Figure 20-12. Port Override for Timer/Counter Type A**



### 20.3.3.5 Timer/Counter Commands

A set of commands can be issued by software to immediately change the state of the peripheral. These commands give direct control of the UPDATE, RESTART, and RESET signals. A command is issued by writing the respective value to the Command bit field (CMD) in the Control E register (TCAn.CTRLESET).

An Update command has the same effect as when an update condition occurs, except that the Update command is not affected by the state of the Lock Update bit (LUPD) in the Control E register (TCAn.CTRLE).

The software can force a restart of the current waveform period by issuing a Restart command. In this case, the counter, direction, and all compare outputs are set to zero.

A Reset command will set all timer/counter registers to their initial values. A Reset can be issued only when the timer/counter is not running (ENABLE=0 in TCAn.CTRLA).

### 20.3.3.6 Split Mode - Two 8-Bit Timer/Counters

#### Split Mode Overview

To double the number of timers and PWM channels in the TCA, a Split mode is provided. In this Split mode, the 16-bit timer/counter acts as two separate 8-bit timers, which each have three compare channels for PWM generation. The Split mode will only work with single-slope down-count. Split mode does not support event action controlled operation.

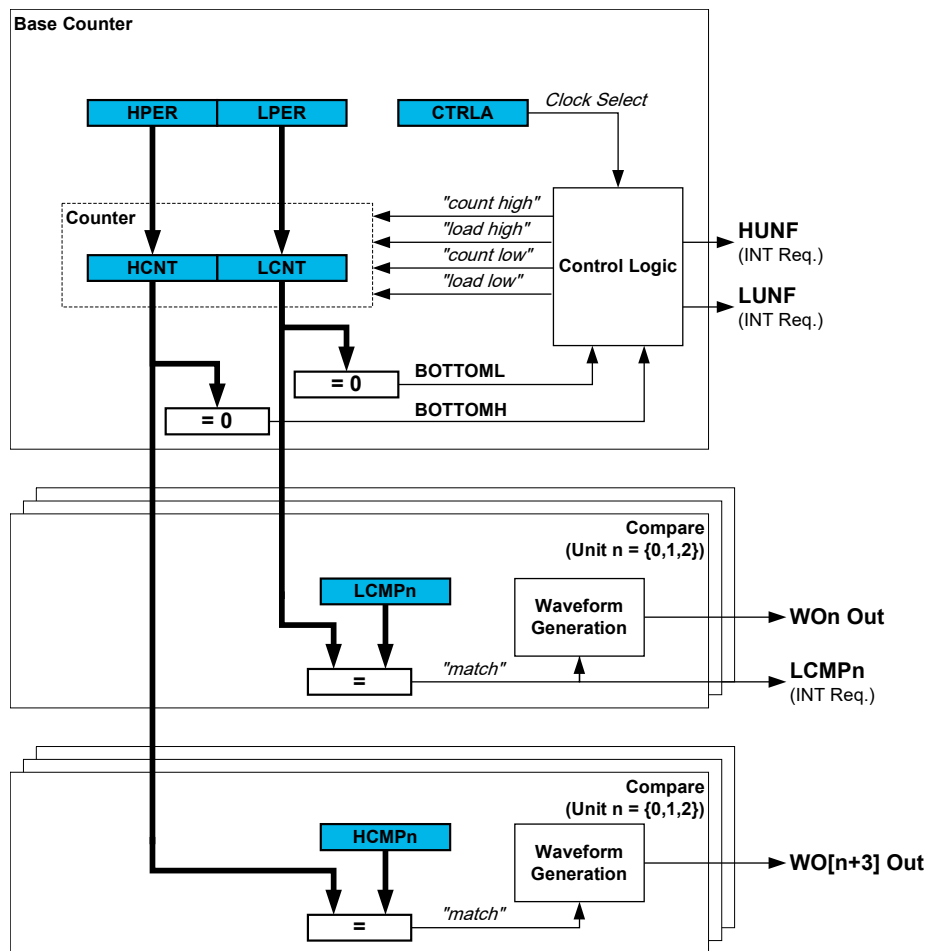
#### Split Mode Differences to Normal Mode

- Count:
  - Down-count only
  - Timer/counter Counter high byte and Counter low byte are independent (TCAn.LCNT, TCAn.HCNT)
- Waveform Generation:
  - Single-slope PWM only (WGMODE=SINGLESLOPE in TCAn.CTRLB)
- Interrupt:
  - No change for low byte Timer/Counter (TCAn.LCNT)
  - Underflow interrupt for high byte Timer/Counter (TCAn.HCNT)
  - No compare interrupt or flag for High-byte Compare n registers (TCAn.HCMPn)
- Event Actions: Not Compatible
- Buffer registers and Buffer Valid Flags: Unused
- Register Access: Byte Access to all registers
- Temp register: Unused, 16-bit register of the Normal mode are Accessed as 8-bit 'TCA\_H' and 'TCA\_L', Respectively



### Block Diagram

Figure 20-13. Timer/Counter Block Diagram Split Mode



### Split Mode Initialization

When shifting between Normal mode and Split mode, the functionality of some registers and bits changes, but their values do not. For this reason, disabling the peripheral (ENABLE=0 in TCAn.CTRLA) and doing a hard Reset (CMD=RESET in TCAn.CTRLSET) is recommended when changing the mode to avoid unexpected behavior.

To start using the timer/counter in basic Split mode after a hard Reset, follow these steps:

- Enable Split mode by writing a '1' to the Split mode enable bit in the Control D register (SPLITM in TCAn.CTRLD)
- Write a TOP value to the Period registers (TCAn.PER)
- Enable the peripheral by writing a '1' to the ENABLE bit in the Control A register (TCAn.CTRLA). The counter will start counting clock ticks according to the prescaler setting in the Clock Select bit field (CLKSEL) in TCAn.CTRLA.
- The counter values can be read from the Counter bit field in the Counter registers (TCAn.CNT)

Activating Split mode results in changes to the functionality of some registers and register bits. The modifications are described in a separate register map.

### 20.3.4 Events

The TCA is an event generator. The following events will generate a one-cycle strobe on the event channel outputs:

- Timer overflow
- Timer underflow in Split mode
- Compare match channel 0
- Compare match channel 1
- Compare match channel 2

The peripheral can take the following actions on an input event:

- The counter counts positive edges of the event signal.
- The counter counts both positive and negative edges of the event signal.
- The counter counts prescaled clock cycles as long as the event signal is high.
- The counter counts prescaled clock cycles. The event signal controls the direction of counting. Up-counting when the event signal is low and down-counting when the event signal is high.

The specific action is selected by writing to the Event Action bits (EVACT) in the Event Control register (TCA<sub>n</sub>.EVCTRL). Events as input are enabled by writing a '1' to the Enable Count on Event Input bit (CNTEI in TCA<sub>n</sub>.EVCTRL).

Event-controlled inputs are not used in Split mode.

### 20.3.5 Interrupts

**Table 20-3. Available Interrupt Vectors and Sources in Normal Mode**

Offset	Name	Vector Description	Conditions
0x00	OVF	Overflow and compare match interrupt	The counter has reached its top value and wrapped to zero.
0x04	CMP0	Compare channel 0 interrupt	Match between the counter value and the Compare 0 register.
0x06	CMP1	Compare channel 1 interrupt	Match between the counter value and the Compare 1 register.
0x08	CMP2	Compare channel 2 interrupt	Match between the counter value and the Compare 2 register.

**Table 20-4. Available Interrupt Vectors and Sources in Split Mode**

Offset	Name	Vector Description	Conditions
0x00	LUNF	Low byte underflow interrupt	Low byte timer reaches BOTTOM.
0x02	HUNF	High byte underflow interrupt	High byte timer reaches BOTTOM.
0x04	LCMP0	Compare channel 0 interrupt	Match between the counter value and the low byte of Compare 0 register.

Offset	Name	Vector Description	Conditions
0x06	LCMP1	Compare channel 1 interrupt	Match between the counter value and the low byte of Compare 1 register.
0x08	LCMP2	Compare channel 2 interrupt	Match between the counter value and the low byte of the Compare 2 register.

When an interrupt condition occurs, the corresponding interrupt flag is set in the Interrupt Flags register of the peripheral (*peripheral*.INTFLAGS).

An interrupt source is enabled or disabled by writing to the corresponding enable bit in the peripheral's Interrupt Control register (*peripheral*.INTCTRL).

An interrupt request is generated when the corresponding interrupt source is enabled and the interrupt flag is set. The interrupt request remains active until the interrupt flag is cleared. See the peripheral's INTFLAGS register for details on how to clear interrupt flags.

### Related Links

[8. AVR CPU](#)

[8.7.3 SREG](#)

### 20.3.6 Sleep Mode Operation

The timer/counter will continue operation in Idle Sleep mode.

### 20.3.7 Configuration Change Protection

Not applicable.

### 20.4 Register Summary - TCA in Normal Mode (CTRLD.SPLITM=0)

Offset	Name	Bit Pos.								
0x00	CTRLA	7:0						CLKSEL[2:0]		ENABLE
0x01	CTRLB	7:0		CMP2EN	CMP1EN	CMP0EN	ALUPD		WGMODE[2:0]	
0x02	CTRLC	7:0						CMP2OV	CMP1OV	CMP0OV
0x03	CTRLD	7:0								SPLITM
0x04	CTRLECLR	7:0						CMD[1:0]	LUPD	DIR
0x05	CTRLESET	7:0						CMD[1:0]	LUPD	DIR
0x06	CTRLFCLR	7:0						CMP2BV	CMP1BV	CMP0BV
0x07	CTRLFSET	7:0						CMP2BV	CMP1BV	CMP0BV
0x08	Reserved									
0x09	EVCTRL	7:0							EVACT[1:0]	CNTEI
0x0A	INTCTRL	7:0		CMP2	CMP1	CMP0				OVF
0x0B	INTFLAGS	7:0		CMP2	CMP1	CMP0				OVF
0x0C	...									
0x0D	Reserved									
0x0E	DBGCTRL	7:0								DBGRUN
0x0F	TEMP	7:0								TEMP[7:0]
0x10	...									
0x1F	Reserved									
0x20	CNT	7:0								CNT[7:0]
		15:8								CNT[15:8]
0x22	...									
0x25	Reserved									
0x26	PER	7:0								PER[7:0]
		15:8								PER[15:8]
0x28	CMP0	7:0								CMP[7:0]
		15:8								CMP[15:8]
0x2A	CMP1	7:0								CMP[7:0]
		15:8								CMP[15:8]
0x2C	CMP2	7:0								CMP[7:0]
		15:8								CMP[15:8]
0x2E	...									
0x35	Reserved									
0x36	PERBUF	7:0								PERBUF[7:0]
		15:8								PERBUF[15:8]
0x38	CMP0BUF	7:0								CMPBUF[7:0]
		15:8								CMPBUF[15:8]
0x3A	CMP1BUF	7:0								CMPBUF[7:0]
		15:8								CMPBUF[15:8]
0x3C	CMP2BUF	7:0								CMPBUF[7:0]
		15:8								CMPBUF[15:8]

## 20.5 Register Description - Normal Mode

### 20.5.1 Control A

**Name:** CTRLA  
**Offset:** 0x00  
**Reset:** 0x00  
**Property:** -

Bit	7	6	5	4	3	2	1	0
					CLKSEL[2:0]			ENABLE
Access					R/W	R/W	R/W	R/W
Reset					0	0	0	0

#### Bits 3:1 – CLKSEL[2:0] Clock Select

These bits select the clock frequency for the timer/counter.

Value	Name	Description
0x0	DIV1	$f_{TCA} = f_{CLK\_PER}/1$
0x1	DIV2	$f_{TCA} = f_{CLK\_PER}/2$
0x2	DIV4	$f_{TCA} = f_{CLK\_PER}/4$
0x3	DIV8	$f_{TCA} = f_{CLK\_PER}/8$
0x4	DIV16	$f_{TCA} = f_{CLK\_PER}/16$
0x5	DIV64	$f_{TCA} = f_{CLK\_PER}/64$
0x6	DIV256	$f_{TCA} = f_{CLK\_PER}/256$
0x7	DIV1024	$f_{TCA} = f_{CLK\_PER}/1024$

#### Bit 0 – ENABLE Enable

Value	Description
0	The peripheral is disabled
1	The peripheral is enabled

### 20.5.2 Control B - Normal Mode

**Name:** CTRLB  
**Offset:** 0x01  
**Reset:** 0x00  
**Property:** -

Bit	7	6	5	4	3	2	1	0
		CMP2EN	CMP1EN	CMP0EN	ALUPD	WGMODE[2:0]		
Access		R/W	R/W	R/W	R/W	R/W	R/W	R/W
Reset		0	0	0	0	0	0	0

#### Bits 4, 5, 6 – CMPEN Compare n Enable

In the FRQ or PWM Waveform Generation mode, these bits will override the PORT output register for the corresponding pin.

Value	Description
0	Port output settings for the pin with WOn output respected
1	Port output settings for pin with WOn output overridden in FRQ or PWM Waveform Generation mode

#### Bit 3 – ALUPD Auto-Lock Update

The Auto-Lock Update feature controls the Lock Update (LUPD) bit in the TCA.CTRLE register. When ALUPD is written to '1', LUPD will be set to '1' until the Buffer Valid (CMPnBV) bits of all enabled compare channels are '1'. This condition will clear LUPD.

It will remain cleared until the next UPDATE condition, where the buffer values will be transferred to the CMPn registers and LUPD will be set to '1' again. This makes sure that CMPnBUF register values are not transferred to the CMPn registers until all enabled compare buffers are written.

Value	Description
0	LUPD in TCA.CTRLE not altered by system
1	LUPD in TCA.CTRLE set and cleared automatically

#### Bits 2:0 – WGMODE[2:0] Waveform Generation Mode

These bits select the Waveform Generation mode and control the counting sequence of the counter, TOP value, UPDATE condition, interrupt condition, and type of waveform that is generated.

No waveform generation is performed in the Normal mode of operation. For all other modes, the result from the waveform generator will only be directed to the port pins if the corresponding CMPnEN bit has been set to enable this. The port pin direction must be set as output.

**Table 20-5. Timer Waveform Generation Mode**

WGMODE[2:0]	Group Configuration	Mode of Operation	Top	Update	OVF
000	NORMAL	Normal	PER	TOP	TOP
001	FRQ	Frequency	CMP0	TOP	TOP
010	-	Reserved	-	-	-
011	SINGLESLOPE	Single-slope PWM	PER	BOTTOM	BOTTOM

WGMODE[2:0]	Group Configuration	Mode of Operation	Top	Update	OVF
100	-	Reserved	-	-	-
101	DSTOP	Dual-slope PWM	PER	BOTTOM	TOP
110	DSBOTH	Dual-slope PWM	PER	BOTTOM	TOP and BOTTOM
111	DSBOTTOM	Dual-slope PWM	PER	BOTTOM	BOTTOM

Value	Name	Description
0x0	NORMAL	Normal operation mode
0x1	FRQ	Frequency mode
0x3	SINGLESLOPE	Single-slope PWM mode
0x5	DSTOP	Dual-slope PWM mode
0x6	DSBOTH	Dual-slope PWM mode
0x7	DSBOTTOM	Dual-slope PWM mode
Other	-	Reserved



### 20.5.3 Control C - Normal Mode

**Name:** CTRLC  
**Offset:** 0x02  
**Reset:** 0x00  
**Property:** -

Bit	7	6	5	4	3	2	1	0
						CMP2OV	CMP1OV	CMP0OV
Access						R/W	R/W	R/W
Reset						0	0	0

**Bit 2 – CMP2OV** Compare Output Value 2  
 See CMP0OV.

**Bit 1 – CMP1OV** Compare Output Value 1  
 See CMP0OV.

**Bit 0 – CMP0OV** Compare Output Value 0  
 The CMPnOV bits allow direct access to the waveform generator's output compare value when the timer/counter is not enabled. This is used to set or clear the WG output value when the timer/counter is not running.

### 20.5.4 Control D

**Name:** CTRLD  
**Offset:** 0x03  
**Reset:** 0x00  
**Property:** -

Bit	7	6	5	4	3	2	1	0
								SPLITM
Access								R/W
Reset								0

#### Bit 0 – SPLITM Enable Split Mode

This bit sets the timer/counter in Split mode operation. It will then work as two 8-bit timer/counters. The register map will change compared to normal 16-bit mode.

### 20.5.5 Control Register E Clear - Normal Mode

**Name:** CTRLLECLR  
**Offset:** 0x04  
**Reset:** 0x00  
**Property:** -

The individual Status bit can be cleared by writing a '1' to its bit location. This allows each bit to be cleared without the use of a read-modify-write operation on a single register.

Each Status bit can be read out either by reading TCA<sub>n</sub>.CTRLESET or TCA<sub>n</sub>.CTRLLECLR.

Bit	7	6	5	4	3	2	1	0
					CMD[1:0]		LUPD	DIR
Access					R/W	R/W	R/W	R/W
Reset					0	0	0	0

#### Bits 3:2 – CMD[1:0] Command

These bits are used for software control of update, restart, and reset of the timer/counter. The command bits are always read as '0'.

Value	Name	Description
0x0	NONE	No command
0x1	UPDATE	Force update
0x2	RESTART	Force restart
0x3	RESET	Force hard Reset (ignored if TC is enabled)

#### Bit 1 – LUPD Lock Update

Lock update can be used to ensure that all buffers are valid before an update is performed.

Value	Description
0	The buffered registers are updated as soon as an UPDATE condition has occurred.
1	No update of the buffered registers is performed, even though an UPDATE condition has occurred.

#### Bit 0 – DIR Counter Direction

Normally this bit is controlled in hardware by the Waveform Generation mode or by event actions, but this bit can also be changed from software.

Value	Description
0	The counter is counting up (incrementing)
1	The counter is counting down (decrementing)

### 20.5.6 Control Register E Set - Normal Mode

**Name:** CTRLRESET  
**Offset:** 0x05  
**Reset:** 0x00  
**Property:** -

The individual Status bit can be set by writing a '1' to its bit location. This allows each bit to be set without the use of a read-modify-write operation on a single register.

Each Status bit can be read out either by reading TCAn.CTRLRESET or TCAn.CTRLRCLR.

Bit	7	6	5	4	3	2	1	0
					CMD[1:0]		LUPD	DIR
Access					R/W	R/W	R/W	R/W
Reset					0	0	0	0

#### Bits 3:2 – CMD[1:0] Command

These bits are used for software control of update, restart, and reset the timer/counter. The command bits are always read as '0'.

Value	Name	Description
0x0	NONE	No command
0x1	UPDATE	Force update
0x2	RESTART	Force restart
0x3	RESET	Force hard Reset (ignored if TC is enabled)

#### Bit 1 – LUPD Lock Update

Locking the update ensures that all buffers are valid before an update is performed.

Value	Description
0	The buffered registers are updated as soon as an UPDATE condition has occurred.
1	No update of the buffered registers is performed, even though an UPDATE condition has occurred.

#### Bit 0 – DIR Counter Direction

Normally this bit is controlled in hardware by the Waveform Generation mode or by event actions, but this bit can also be changed from software.

Value	Description
0	The counter is counting up (incrementing)
1	The counter is counting down (decrementing)

### 20.5.7 Control Register F Clear

**Name:** CTRLFCLR  
**Offset:** 0x06  
**Reset:** 0x00  
**Property:** -

The individual Status bit can be cleared by writing a '1' to its bit location. This allows each bit to be cleared without the use of a read-modify-write operation on a single register.

Bit	7	6	5	4	3	2	1	0
					CMP2BV	CMP1BV	CMP0BV	PERBV
Access					R/W	R/W	R/W	R/W
Reset					0	0	0	0

**Bit 3 – CMP2BV** Compare 2 Buffer Valid  
 See CMP0BV.

**Bit 2 – CMP1BV** Compare 1 Buffer Valid  
 See CMP0BV.

**Bit 1 – CMP0BV** Compare 0 Buffer Valid  
 The CMPnBV bits are set when a new value is written to the corresponding TCAn.CMPnBUF register. These bits are automatically cleared on an UPDATE condition.

**Bit 0 – PERBV** Period Buffer Valid  
 This bit is set when a new value is written to the TCAn.PERBUF register. This bit is automatically cleared on an UPDATE condition.

### 20.5.8 Control Register F Set

**Name:** CTRLFSET  
**Offset:** 0x07  
**Reset:** 0x00  
**Property:** -

The individual status bit can be set by writing a '1' to its bit location. This allows each bit to be set without the use of a read-modify-write operation on a single register.

Bit	7	6	5	4	3	2	1	0
					CMP2BV	CMP1BV	CMP0BV	PERBV
Access					R/W	R/W	R/W	R/W
Reset					0	0	0	0

**Bit 3 – CMP2BV** Compare 2 Buffer Valid  
See CMP0BV.

**Bit 2 – CMP1BV** Compare 1 Buffer Valid  
See CMP0BV.

**Bit 1 – CMP0BV** Compare 0 Buffer Valid  
The CMPnBV bits are set when a new value is written to the corresponding TCAn.CMPnBUF register. These bits are automatically cleared on an UPDATE condition.

**Bit 0 – PERBV** Period Buffer Valid  
This bit is set when a new value is written to the TCAn.PERBUF register. This bit is automatically cleared on an UPDATE condition.

### 20.5.9 Event Control

**Name:** EVCTRL  
**Offset:** 0x09  
**Reset:** 0x00  
**Property:** -

Bit	7	6	5	4	3	2	1	0
						EVACT[1:0]		CNTEI
Access						R/W	R/W	R/W
Reset						0	0	0

#### Bits 2:1 – EVACT[1:0] Event Action

These bits define what type of event action the counter will increment or decrement.

Value	Name	Description
0x0	EVACT_POSEDGE	Count on positive edge event
0x1	EVACT_ANYEDGE	Count on any edge event
0x2	EVACT_HIGHLVL	Count on prescaled clock while event line is 1.
0x3	EVACT_UPDOWN	Count on prescaled clock. The Event controls the count direction. Up-counting when the event line is 0, down-counting when the event line is 1.

#### Bit 0 – CNTEI Enable Count on Event Input

Value	Description
0	Counting on Event input is disabled
1	Counting on Event input is enabled according to EVACT bit field

### 20.5.10 Interrupt Control Register - Normal Mode

**Name:** INTCTRL  
**Offset:** 0x0A  
**Reset:** 0x00  
**Property:** -

Bit	7	6	5	4	3	2	1	0
		CMP2	CMP1	CMP0				OVF
Access		R/W	R/W	R/W				R/W
Reset		0	0	0				0

**Bit 6 – CMP2** Compare Channel 2 Interrupt Enable  
 See CMP0.

**Bit 5 – CMP1** Compare Channel 1 Interrupt Enable  
 See CMP0.

**Bit 4 – CMP0** Compare Channel 0 Interrupt Enable  
 Writing the CMPn bits to '1' enable compare interrupt from channel n.

**Bit 0 – OVF** Timer Overflow/Underflow Interrupt Enable  
 Writing the OVF bit to '1' enables overflow interrupt.



### 20.5.11 Interrupt Flag Register - Normal Mode

**Name:** INTFLAGS  
**Offset:** 0x0B  
**Reset:** 0x00  
**Property:** -

The individual Status bit can be cleared by writing a '1' to its bit location. This allows each bit to be set without the use of a read-modify-write operation on a single register.

Bit	7	6	5	4	3	2	1	0
		CMP2	CMP1	CMP0				OVF
Access		R/W	R/W	R/W				R/W
Reset		0	0	0				0

**Bit 6 – CMP2** Compare Channel 2 Interrupt Flag  
See CMP0 flag description.

**Bit 5 – CMP1** Compare Channel 1 Interrupt Flag  
See CMP0 flag description.

**Bit 4 – CMP0** Compare Channel 0 Interrupt Flag  
The Compare Interrupt flag (CMPn) is set on a compare match on the corresponding compare channel. For all modes of operation, the CMPn flag will be set when a compare match occurs between the Count register (TCA<sub>n</sub>.CNT) and the corresponding Compare register (TCA<sub>n</sub>.CMPn). The CMPn flag is not cleared automatically, only by writing a '1' to its bit location.

**Bit 0 – OVF** Overflow/Underflow Interrupt Flag  
This flag is set either on a TOP (overflow) or BOTTOM (underflow) condition, depending on the WGMODE setting. The OVF flag is not cleared automatically, only by writing a '1' to its bit location.

### 20.5.12 Debug Control Register

**Name:** DBGCTRL  
**Offset:** 0x0E  
**Reset:** 0x00  
**Property:** -

Bit	7	6	5	4	3	2	1	0
								DBGRUN
Access								R/W
Reset								0

#### Bit 0 – DBGRUN Run in Debug

Value	Description
0	The peripheral is halted in Break Debug mode and ignores events
1	The peripheral will continue to run in Break Debug mode when the CPU is halted

### 20.5.13 Temporary Bits for 16-Bit Access

**Name:** TEMP  
**Offset:** 0x0F  
**Reset:** 0x00  
**Property:** -

The Temporary register is used by the CPU for single-cycle, 16-bit access to the 16-bit registers of this peripheral. It can be read and written by software. Refer to 16-bit access in the AVR CPU chapter. There is one common Temporary register for all the 16-bit registers of this peripheral.

Bit	7	6	5	4	3	2	1	0
	TEMP[7:0]							
Access	R/W	R/W	R/W	R/W	R/W	R/W	R/W	R/W
Reset	0	0	0	0	0	0	0	0

**Bits 7:0 – TEMP[7:0]** Temporary Bits for 16-bit Access

### 20.5.14 Counter Register - Normal Mode

**Name:** CNT  
**Offset:** 0x20  
**Reset:** 0x00  
**Property:** -

The TCA<sub>n</sub>.CNTL and TCA<sub>n</sub>.CNTH register pair represents the 16-bit value, TCA<sub>n</sub>.CNT. The low byte [7:0] (suffix L) is accessible at the original offset. The high byte [15:8] (suffix H) can be accessed at offset + 0x01.

CPU and UPDI write access has priority over internal updates of the register.

Bit	15	14	13	12	11	10	9	8
CNT[15:8]								
Access	R/W	R/W	R/W	R/W	R/W	R/W	R/W	R/W
Reset	0	0	0	0	0	0	0	0
Bit	7	6	5	4	3	2	1	0
CNT[7:0]								
Access	R/W	R/W	R/W	R/W	R/W	R/W	R/W	R/W
Reset	0	0	0	0	0	0	0	0

#### Bits 15:8 – CNT[15:8] Counter High Byte

These bits hold the MSB of the 16-bit counter register.

#### Bits 7:0 – CNT[7:0] Counter Low Byte

These bits hold the LSB of the 16-bit counter register.

### 20.5.15 Period Register - Normal Mode

**Name:** PER  
**Offset:** 0x26  
**Reset:** 0xFFFF  
**Property:** -

TCA<sub>n</sub>.PER contains the 16-bit TOP value in the timer/counter.

The TCA<sub>n</sub>.PERL and TCA<sub>n</sub>.PERH register pair represents the 16-bit value, TCA<sub>n</sub>.PER. The low byte [7:0] (suffix L) is accessible at the original offset. The high byte [15:8] (suffix H) can be accessed at offset + 0x01.

Bit	15	14	13	12	11	10	9	8
	PER[15:8]							
Access	R/W	R/W	R/W	R/W	R/W	R/W	R/W	R/W
Reset	1	1	1	1	1	1	1	1
Bit	7	6	5	4	3	2	1	0
	PER[7:0]							
Access	R/W	R/W	R/W	R/W	R/W	R/W	R/W	R/W
Reset	1	1	1	1	1	1	1	1

#### Bits 15:8 – PER[15:8] Periodic High Byte

These bits hold the MSB of the 16-bit period register.

#### Bits 7:0 – PER[7:0] Periodic Low Byte

These bits hold the LSB of the 16-bit period register.

### 20.5.16 Compare n Register - Normal Mode

**Name:** CMPn  
**Offset:** 0x28 + n\*0x02 [n=0..2]  
**Reset:** 0x00  
**Property:** -

This register is continuously compared to the counter value. Normally, the outputs from the comparators are then used for generating waveforms.

TCA<sub>n</sub>.CMP<sub>n</sub> registers are updated with the buffer value from their corresponding TCA<sub>n</sub>.CMP<sub>n</sub>BUF register when an UPDATE condition occurs.

The TCA<sub>n</sub>.CMP<sub>n</sub>L and TCA<sub>n</sub>.CMP<sub>n</sub>H register pair represents the 16-bit value, TCA<sub>n</sub>.CMP<sub>n</sub>. The low byte [7:0] (suffix L) is accessible at the original offset. The high byte [15:8] (suffix H) can be accessed at offset + 0x01.

Bit	15	14	13	12	11	10	9	8
CMP[15:8]								
Access	R/W	R/W	R/W	R/W	R/W	R/W	R/W	R/W
Reset	0	0	0	0	0	0	0	0
Bit	7	6	5	4	3	2	1	0
CMP[7:0]								
Access	R/W	R/W	R/W	R/W	R/W	R/W	R/W	R/W
Reset	0	0	0	0	0	0	0	0

#### Bits 15:8 – CMP[15:8] Compare High Byte

These bits hold the MSB of the 16-bit compare register.

#### Bits 7:0 – CMP[7:0] Compare Low Byte

These bits hold the LSB of the 16-bit compare register.

### 20.5.17 Period Buffer Register

**Name:** PERBUF  
**Offset:** 0x36  
**Reset:** 0xFFFF  
**Property:** -

This register serves as the buffer for the period register (TCAn.PER). Accessing this register using the CPU or UPDI will affect the PERBV flag.

The TCAn.PERBUFL and TCAn.PERBUFH register pair represents the 16-bit value, TCAn.PERBUF. The low byte [7:0] (suffix L) is accessible at the original offset. The high byte [15:8] (suffix H) can be accessed at offset + 0x01.

Bit	15	14	13	12	11	10	9	8
PERBUF[15:8]								
Access	R/W	R/W	R/W	R/W	R/W	R/W	R/W	R/W
Reset	1	1	1	1	1	1	1	1
Bit	7	6	5	4	3	2	1	0
PERBUF[7:0]								
Access	R/W	R/W	R/W	R/W	R/W	R/W	R/W	R/W
Reset	1	1	1	1	1	1	1	1

#### Bits 15:8 – PERBUF[15:8] Period Buffer High Byte

These bits hold the MSB of the 16-bit period buffer register.

#### Bits 7:0 – PERBUF[7:0] Period Buffer Low Byte

These bits hold the LSB of the 16-bit period buffer register.

### 20.5.18 Compare n Buffer Register

**Name:** CMPBUF  
**Offset:** 0x38 + n\*0x02 [n=0..2]  
**Reset:** 0x00  
**Property:** -

This register serves as the buffer for the associated compare registers (TCAn.CMPn). Accessing any of these registers using the CPU or UPDI will affect the corresponding CMPnBV status bit.

The TCAn.CMPnBUFL and TCAn.CMPnBUFH register pair represents the 16-bit value, TCAn.CMPnBUF. The low byte [7:0] (suffix L) is accessible at the original offset. The high byte [15:8] (suffix H) can be accessed at offset + 0x01.

Bit	15	14	13	12	11	10	9	8
CMPBUF[15:8]								
Access	R/W	R/W	R/W	R/W	R/W	R/W	R/W	R/W
Reset	0	0	0	0	0	0	0	0
Bit	7	6	5	4	3	2	1	0
CMPBUF[7:0]								
Access	R/W	R/W	R/W	R/W	R/W	R/W	R/W	R/W
Reset	0	0	0	0	0	0	0	0

#### Bits 15:8 – CMPBUF[15:8] Compare High Byte

These bits hold the MSB of the 16-bit compare buffer register.

#### Bits 7:0 – CMPBUF[7:0] Compare Low Byte

These bits hold the LSB of the 16-bit compare buffer register.



### 20.6 Register Summary - TCA in Split Mode (CTRLD.SPLITM=1)

Offset	Name	Bit Pos.								
0x00	<a href="#">CTRLA</a>	7:0						CLKSEL[2:0]		ENABLE
0x01	<a href="#">CTRLB</a>	7:0		HCMP2EN	HCMP1EN	HCMP0EN		LCMP2EN	LCMP1EN	LCMP0EN
0x02	<a href="#">CTRLC</a>	7:0		HCMP2OV	HCMP1OV	HCMP0OV		LCMP2OV	LCMP1OV	LCMP0OV
0x03	<a href="#">CTRLD</a>	7:0								SPLITM
0x04	<a href="#">CTRLECLR</a>	7:0						CMD[1:0]		CMDEN[1:0]
0x05	<a href="#">CTRLESET</a>	7:0						CMD[1:0]		CMDEN[1:0]
0x06	Reserved									
...										
0x09										
0x0A	<a href="#">INTCTRL</a>	7:0		LCMP2	LCMP1	LCMP0			HUNF	LUNF
0x0B	<a href="#">INTFLAGS</a>	7:0		LCMP2	LCMP1	LCMP0			HUNF	LUNF
0x0C	Reserved									
...										
0x0D										
0x0E	<a href="#">DBGCTRL</a>	7:0								DBGRUN
0x0F	Reserved									
...										
0x1F										
0x20	<a href="#">LCNT</a>	7:0						LCNT[7:0]		
0x21	<a href="#">HCNT</a>	7:0						HCNT[7:0]		
0x22	Reserved									
...										
0x25										
0x26		<a href="#">LPER</a>	7:0						LPER[7:0]	
0x27	<a href="#">HPER</a>	7:0						HPER[7:0]		
0x28	<a href="#">LCMP0</a>	7:0						LCMP[7:0]		
0x29	<a href="#">HCMP0</a>	7:0						HCMP[7:0]		
0x2A	<a href="#">LCMP1</a>	7:0						LCMP[7:0]		
0x2B	<a href="#">HCMP1</a>	7:0						HCMP[7:0]		
0x2C	<a href="#">LCMP2</a>	7:0						LCMP[7:0]		
0x2D	<a href="#">HCMP2</a>	7:0						HCMP[7:0]		

### 20.7 Register Description - Split Mode

### 20.7.1 Control A

**Name:** CTRLA  
**Offset:** 0x00  
**Reset:** 0x00  
**Property:** -

Bit	7	6	5	4	3	2	1	0
					CLKSEL[2:0]			ENABLE
Access					R/W	R/W	R/W	R/W
Reset					0	0	0	0

#### Bits 3:1 – CLKSEL[2:0] Clock Select

These bits select the clock frequency for the timer/counter.

Value	Name	Description
0x0	DIV1	$f_{TCA} = f_{CLK\_PER}/1$
0x1	DIV2	$f_{TCA} = f_{CLK\_PER}/2$
0x2	DIV4	$f_{TCA} = f_{CLK\_PER}/4$
0x3	DIV8	$f_{TCA} = f_{CLK\_PER}/8$
0x4	DIV16	$f_{TCA} = f_{CLK\_PER}/16$
0x5	DIV64	$f_{TCA} = f_{CLK\_PER}/64$
0x6	DIV256	$f_{TCA} = f_{CLK\_PER}/256$
0x7	DIV1024	$f_{TCA} = f_{CLK\_PER}/1024$

#### Bit 0 – ENABLE Enable

Value	Description
0	The peripheral is disabled
1	The peripheral is enabled

### 20.7.2 Control B - Split Mode

**Name:** CTRLB  
**Offset:** 0x01  
**Reset:** 0x00  
**Property:** -

Bit	7	6	5	4	3	2	1	0
		HCMP2EN	HCMP1EN	HCMP0EN		LCMP2EN	LCMP1EN	LCMP0EN
Access		R/W	R/W	R/W		R/W	R/W	R/W
Reset		0	0	0		0	0	0

**Bit 6 – HCMP2EN** High byte Compare 2 Enable  
 See LCMP0EN.

**Bit 5 – HCMP1EN** High byte Compare 1 Enable  
 See LCMP0EN.

**Bit 4 – HCMP0EN** High byte Compare 0 Enable  
 See LCMP0EN.

**Bit 2 – LCMP2EN** Low byte Compare 2 Enable  
 See LCMP0EN.

**Bit 1 – LCMP1EN** Low byte Compare 1 Enable  
 See LCMP0EN.

**Bit 0 – LCMP0EN** Low byte Compare 0 Enable  
 Setting the LCMPnEN/HCMPnEN bits in the FRQ or PWM Waveform Generation mode of operation will override the port output register for the corresponding WOn pin.

### 20.7.3 Control C - Split Mode

**Name:** CTRLC  
**Offset:** 0x02  
**Reset:** 0x00  
**Property:** -

Bit	7	6	5	4	3	2	1	0
		HCMP2OV	HCMP1OV	HCMP0OV		LCMP2OV	LCMP1OV	LCMP0OV
Access		R/W	R/W	R/W		R/W	R/W	R/W
Reset		0	0	0		0	0	0

**Bit 6 – HCMP2OV** High byte Compare 2 Output Value  
 See LCMP0OV.

**Bit 5 – HCMP1OV** High byte Compare 1 Output Value  
 See LCMP0OV.

**Bit 4 – HCMP0OV** High byte Compare 0 Output Value  
 See LCMP0OV.

**Bit 2 – LCMP2OV** Low byte Compare 2 Output Value  
 See LCMP0OV.

**Bit 1 – LCMP1OV** Low byte Compare 1 Output Value  
 See LCMP0OV.

**Bit 0 – LCMP0OV** Low byte Compare 0 Output Value  
 The LCMPnOV/HCMPn bits allow direct access to the waveform generator's output compare value when the timer/counter is not enabled. This is used to set or clear the WOn output value when the timer/counter is not running.

### 20.7.4 Control D

**Name:** CTRLD  
**Offset:** 0x03  
**Reset:** 0x00  
**Property:** -

Bit	7	6	5	4	3	2	1	0
								SPLITM
Access								R/W
Reset								0

**Bit 0 – SPLITM** Enable Split Mode

This bit sets the timer/counter in Split mode operation. It will then work as two 8-bit timer/counters. The register map will change compared to normal 16-bit mode.

### 20.7.5 Control Register E Clear - Split Mode

**Name:** CTRLLECLR  
**Offset:** 0x04  
**Reset:** 0x00  
**Property:** -

The individual Status bit can be cleared by writing a '1' to its bit location. This allows each bit to be cleared without the use of a read-modify-write operation on a single register.

Bit	7	6	5	4	3	2	1	0
					CMD[1:0]		CMDEN[1:0]	
Access					R/W	R/W	R/W	R/W
Reset					0	0	0	0

#### Bits 3:2 – CMD[1:0] Command

These bits are used for software control of update, restart, and reset of the timer/counter. The command bits are always read as '0'.

Value	Name	Description
0x0	NONE	No command
0x1	-	Reserved
0x2	RESTART	Force restart
0x3	RESET	Force hard Reset (ignored if TC is enabled)

#### Bits 1:0 – CMDEN[1:0] Command enable

These bits are used to indicate for which timer/counter the command (CMD) is valid.

Value	Name	Description
0x0	NONE	None
0x1	-	Reserved
0x2	-	Reserved
0x3	BOTH	Command valid for both low-byte and high-byte T/C

### 20.7.6 Control Register E Set - Split Mode

**Name:** CTRLRESET  
**Offset:** 0x05  
**Reset:** 0x00  
**Property:** -

The individual Status bit can be set by writing a '1' to its bit location. This allows each bit to be set without the use of a read-modify-write operation on a single register.

Bit	7	6	5	4	3	2	1	0
					CMD[1:0]		CMDEN[1:0]	
Access					R/W	R/W	R/W	R/W
Reset					0	0	0	0

#### Bits 3:2 – CMD[1:0] Command

These bits are used for software control of update, restart, and reset of the timer/counter. The command bits are always read as '0'. The CMD bits must be used together with CMDEN. Using the reset command requires that both low-byte and high-byte timer/counter is selected.

Value	Name	Description
0x0	NONE	No command
0x1	-	Reserved
0x2	RESTART	Force restart
0x3	RESET	Force hard Reset (ignored if TC is enabled)

#### Bits 1:0 – CMDEN[1:0] Command enable

These bits are used to indicate for which timer/counter the command (CMD) is valid.

Value	Name	Description
0x0	NONE	None
0x1	-	Reserved
0x2	-	Reserved
0x3	BOTH	Command valid for both low-byte and high-byte T/C

### 20.7.7 Interrupt Control Register - Split Mode

**Name:** INTCTRL  
**Offset:** 0x0A  
**Reset:** 0x00  
**Property:** -

Bit	7	6	5	4	3	2	1	0
		LCMP2	LCMP1	LCMP0			HUNF	LUNF
Access		R/W	R/W	R/W			R/W	R/W
Reset		0	0	0			0	0

**Bit 6 – LCMP2** Low byte Compare Channel 0 Interrupt Enable  
 See LCMP0.

**Bit 5 – LCMP1** Low byte Compare Channel 1 Interrupt Enable  
 See LCMP0.

**Bit 4 – LCMP0** Low byte Compare Channel 0 Interrupt Enable  
 Writing LCMPn bit to '1' enables low byte compare interrupt from channel n.

**Bit 1 – HUNF** High byte Underflow Interrupt Enable  
 Writing HUNF bit to '1' enables high byte underflow interrupt.

**Bit 0 – LUNF** Low byte Underflow Interrupt Enable  
 Writing HUNF bit to '1' enables low byte underflow interrupt.



### 20.7.8 Interrupt Flag Register - Split Mode

**Name:** INTFLAGS  
**Offset:** 0x0B  
**Reset:** 0x00  
**Property:** -

The individual Status bit can be cleared by writing a '1' to its bit location. This allows each bit to be set without the use of a read-modify-write operation on a single register.

Bit	7	6	5	4	3	2	1	0
		LCMP2	LCMP1	LCMP0			HUNF	LUNF
Access		R/W	R/W	R/W			R/W	R/W
Reset		0	0	0			0	0

**Bit 6 – LCMP2** Low byte Compare Channel 0 Interrupt Flag  
See LCMP0 flag description.

**Bit 5 – LCMP1** Low byte Compare Channel 0 Interrupt Flag  
See LCMP0 flag description.

**Bit 4 – LCMP0** Low byte Compare Channel 0 Interrupt Flag  
The Compare Interrupt flag (LCMPn) is set on a compare match on the corresponding compare channel. For all modes of operation, the LCMPn flag will be set when a compare match occurs between the Low Byte Count register (TCA<sub>n</sub>.LCNT) and the corresponding compare register (TCA<sub>n</sub>.LCMPn). The LCMPn flag will not be cleared automatically and has to be cleared by software. This is done by writing a '1' to its bit location.

**Bit 1 – HUNF** High byte Underflow Interrupt Flag  
This flag is set on a high byte timer BOTTOM (underflow) condition. HUNF is not automatically cleared and needs to be cleared by software. This is done by writing a '1' to its bit location.

**Bit 0 – LUNF** Low byte Underflow Interrupt Flag  
This flag is set on a low byte timer BOTTOM (underflow) condition. LUNF is not automatically cleared and needs to be cleared by software. This is done by writing a '1' to its bit location.

### 20.7.9 Debug Control Register

**Name:** DBGCTRL  
**Offset:** 0x0E  
**Reset:** 0x00  
**Property:** -

Bit	7	6	5	4	3	2	1	0
								DBGRUN
Access								R/W
Reset								0

#### Bit 0 – DBGRUN Run in Debug

Value	Description
0	The peripheral is halted in Break Debug mode and ignores events
1	The peripheral will continue to run in Break Debug mode when the CPU is halted

### 20.7.10 Low Byte Timer Counter Register - Split Mode

**Name:** LCNT  
**Offset:** 0x20  
**Reset:** 0x00  
**Property:** -

TCA<sub>n</sub>.LCNT contains the counter value in low byte timer. CPU and UPDI write access has priority over count, clear, or reload of the counter.

Bit	7	6	5	4	3	2	1	0
	LCNT[7:0]							
Access	R/W	R/W	R/W	R/W	R/W	R/W	R/W	R/W
Reset	0	0	0	0	0	0	0	0

**Bits 7:0 – LCNT[7:0]** Counter Value for Low Byte Timer  
 These bits define the counter value of the low byte timer.

### 20.7.11 High Byte Timer Counter Register - Split Mode

**Name:** HCNT  
**Offset:** 0x21  
**Reset:** 0x00  
**Property:** -

TCA<sub>n</sub>.HCNT contains the counter value in high byte timer. CPU and UPDI write access has priority over count, clear, or reload of the counter.

Bit	7	6	5	4	3	2	1	0
	HCNT[7:0]							
Access	R/W	R/W	R/W	R/W	R/W	R/W	R/W	R/W
Reset	0	0	0	0	0	0	0	0

**Bits 7:0 – HCNT[7:0]** Counter Value for High Byte Timer  
 These bits define the counter value in high byte timer.

### 20.7.12 Low Byte Timer Period Register - Split Mode

**Name:** LPER  
**Offset:** 0x26  
**Reset:** 0x00  
**Property:** -

The TCA<sub>n</sub>.LPER register contains the TOP value of low byte timer.

Bit	7	6	5	4	3	2	1	0
	LPER[7:0]							
Access	R/W	R/W	R/W	R/W	R/W	R/W	R/W	R/W
Reset	1	1	1	1	1	1	1	1

**Bits 7:0 – LPER[7:0]** Period Value Low Byte Timer  
 These bits hold the TOP value of low byte timer.

### 20.7.13 High Byte Period Register - Split Mode

**Name:** HPER  
**Offset:** 0x27  
**Reset:** 0x00  
**Property:** -

The TCA<sub>n</sub>.HPER register contains the TOP value of high byte timer.

Bit	7	6	5	4	3	2	1	0
	HPER[7:0]							
Access	R/W	R/W	R/W	R/W	R/W	R/W	R/W	R/W
Reset	1	1	1	1	1	1	1	1

**Bits 7:0 – HPER[7:0]** Period Value High Byte Timer  
 These bits hold the TOP value of high byte timer.

### 20.7.14 Compare Register n For Low Byte Timer - Split Mode

**Name:** LCMP  
**Offset:** 0x28 + n\*0x02 [n=0..2]  
**Reset:** 0x00  
**Property:** -

The TCA<sub>n</sub>.LCMP<sub>n</sub> register represents the compare value of compare channel n for low byte timer. This register is continuously compared to the counter value of the low byte timer, TCA<sub>n</sub>.LCNT. Normally, the outputs from the comparators are then used for generating waveforms.

Bit	7	6	5	4	3	2	1	0
	LCMP[7:0]							
Access	R/W	R/W	R/W	R/W	R/W	R/W	R/W	R/W
Reset	0	0	0	0	0	0	0	0

**Bits 7:0 – LCMP[7:0]** Compare Value of Channel n

These bits hold the compare value of channel n that is compared to TCA<sub>n</sub>.LCNT.

### 20.7.15 High Byte Compare Register n - Split Mode

**Name:** HCMP  
**Offset:**  $0x29 + n \cdot 0x02$  [ $n=0..2$ ]  
**Reset:** 0x00  
**Property:** -

The TCA $n$ .HCMP $n$  register represents the compare value of compare channel  $n$  for high byte timer. This register is continuously compared to the counter value of the high byte timer, TCA $n$ .HCNT. Normally, the outputs from the comparators are then used for generating waveforms.

Bit	7	6	5	4	3	2	1	0
	HCMP[7:0]							
Access	R/W	R/W	R/W	R/W	R/W	R/W	R/W	R/W
Reset	0	0	0	0	0	0	0	0

#### Bits 7:0 – HCMP[7:0] Compare Value of Channel $n$

These bits hold the compare value of channel  $n$  that is compared to TCA $n$ .HCNT.



## **21. TCB - 16-bit Timer/Counter Type B**

### **21.1 Features**

- 16-Bit Counter Operation Modes:
  - Periodic interrupt
  - Time-out check
  - Input capture
    - On event
    - Frequency measurement
    - Pulse-width measurement
    - Frequency and pulse-width measurement
  - Single shot
  - 8-bit Pulse-Width Modulation (PWM)
- Noise Canceler on Event Input
- Optional: Operation Synchronous with TCA0

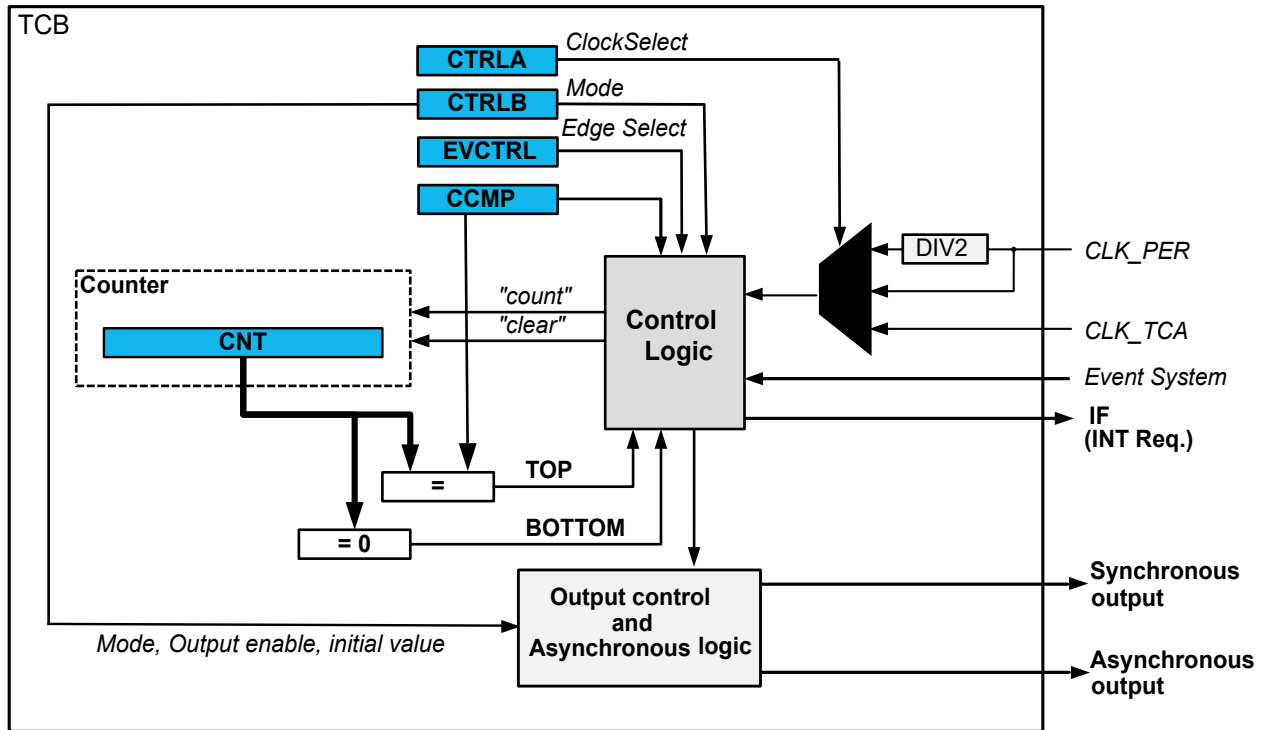
### **21.2 Overview**

The capabilities of the 16-bit Timer/Counter type B (TCB) include frequency and waveform generation, and input capture on event with time and frequency measurement of digital signals. The TCB consists of a base counter and control logic which can be set in one of eight different modes, each mode providing unique functionality. The base counter is clocked by the peripheral clock with optional prescaling.

This device has two instances of the TCB peripheral: TCB0 and TCB1.

21.2.1 Block Diagram

Figure 21-1. Timer/Counter Type B Block Diagram



21.2.1.1 Noise Canceler

The noise canceler improves noise immunity by using a simple digital filter scheme. When the noise filter is enabled, the peripheral monitors the event channel and keeps a record of the last four observed samples. If four consecutive samples are equal, the input is considered to be stable and the signal is fed to the edge detector.

When enabled, the noise canceler introduces an additional delay of four system clock cycles between a change applied to the input and the update of the input compare register.

The noise canceler uses the system clock and is, therefore, not affected by the prescaler.

21.2.2 Signal Description

Signal	Description	Type
WO	Digital Asynchronous Output	Waveform Output

Related Links

[5. I/O Multiplexing and Considerations](#)

21.2.3 System Dependencies

In order to use this peripheral, other parts of the system must be configured correctly, as described below.

**Table 21-1. TCB System Dependencies**

Dependency	Applicable	Peripheral
Clocks	Yes	CLKCTRL
I/O Lines and Connections	Yes	WO
Interrupts	Yes	CPUINT
Events	Yes	EVSYS
Debug	Yes	UPDI

### Related Links

[21.2.3.1 Clocks](#)

[21.2.3.5 Debug Operation](#)

[21.2.3.3 Interrupts](#)

[21.2.3.4 Events](#)

#### 21.2.3.1 Clocks

This peripheral uses the system's peripheral clock CLK\_PER. The peripheral has its own local prescaler or can be configured to run off the prescaled clock signal of the Timer Counter type A (TCA).

### Related Links

[10. CLKCTRL - Clock Controller](#)

#### 21.2.3.2 I/O Lines and Connections

Using the I/O lines of the peripheral requires configuration of the I/O pins.

### Related Links

[5. I/O Multiplexing and Considerations](#)

[16. PORT - I/O Pin Configuration](#)

#### 21.2.3.3 Interrupts

Using the interrupts of this peripheral requires the interrupt controller to be configured first.

### Related Links

[13. CPUINT - CPU Interrupt Controller](#)

[8.7.3 SREG](#)

[21.3.5 Interrupts](#)

#### 21.2.3.4 Events

The events of this peripheral are connected to the Event System.

### Related Links

[14. EVSYS - Event System](#)

#### 21.2.3.5 Debug Operation

When the CPU is halted in Debug mode, this peripheral will halt normal operation. This peripheral can be forced to continue operation during debugging.

This peripheral can be forced to operate with halted CPU by writing a '1' to the Debug Run bit (DBGRUN) in the Debug Control register of the peripheral (*peripheral*.DBGCTRL).

### Related Links

[33. UPDI - Unified Program and Debug Interface](#)

## 21.3 Functional Description

### 21.3.1 Definitions

The following definitions are used throughout the documentation:

**Table 21-2. Timer/Counter Definitions**

Name	Description
BOTTOM	The counter reaches BOTTOM when it becomes zero.
MAX	The counter reaches MAXimum when it becomes all ones.
TOP	The counter reaches TOP when it becomes equal to the highest value in the count sequence.
UPDATE	The update condition is met when the timer/counter reaches BOTTOM or TOP, depending on the Waveform Generator mode.
CNT	Counter register value.
CCMP	Capture/Compare register value.

In general, the term timer is used when the timer/counter is counting periodic clock ticks. The term counter is used when the input signal has sporadic or irregular ticks.

### 21.3.2 Initialization

By default, the TCB is in Periodic Interrupt mode. Follow these steps to start using it:

- Write a TOP value to the Compare/Capture register (TCBn.CCMP).
- Enable the counter by writing a '1' to the ENABLE bit in the Control A register (TCBn.CTRLA). The counter will start counting clock ticks according to the prescaler setting in the Clock Select bit field (CLKSEL in TCBn.CTRLA).
- The counter value can be read from the Count register (TCBn.CNT). The peripheral will generate an interrupt when the CNT value reaches TOP.

### 21.3.3 Operation

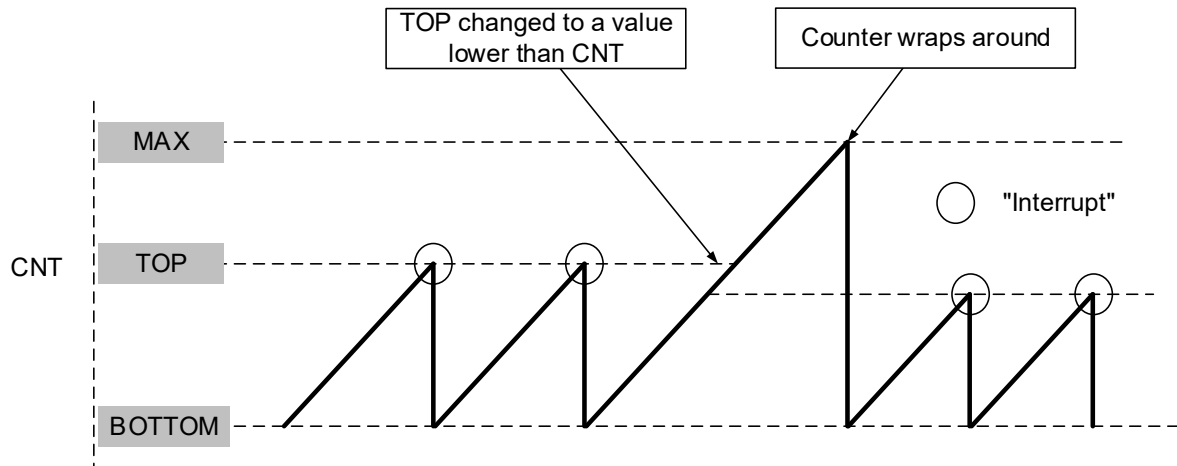
#### 21.3.3.1 Modes

The timer can be configured to run in one of the eight different modes listed below. The event pulse needs to be longer than one system clock cycle in order to ensure edge detection.

##### 21.3.3.1.1 Periodic Interrupt Mode

In the Periodic Interrupt mode, the counter counts to the capture value and restarts from zero. An interrupt is generated when the counter is equal to TOP. If TOP is updated to a value lower than count, the counter will continue until MAX and wrap around without generating an interrupt.

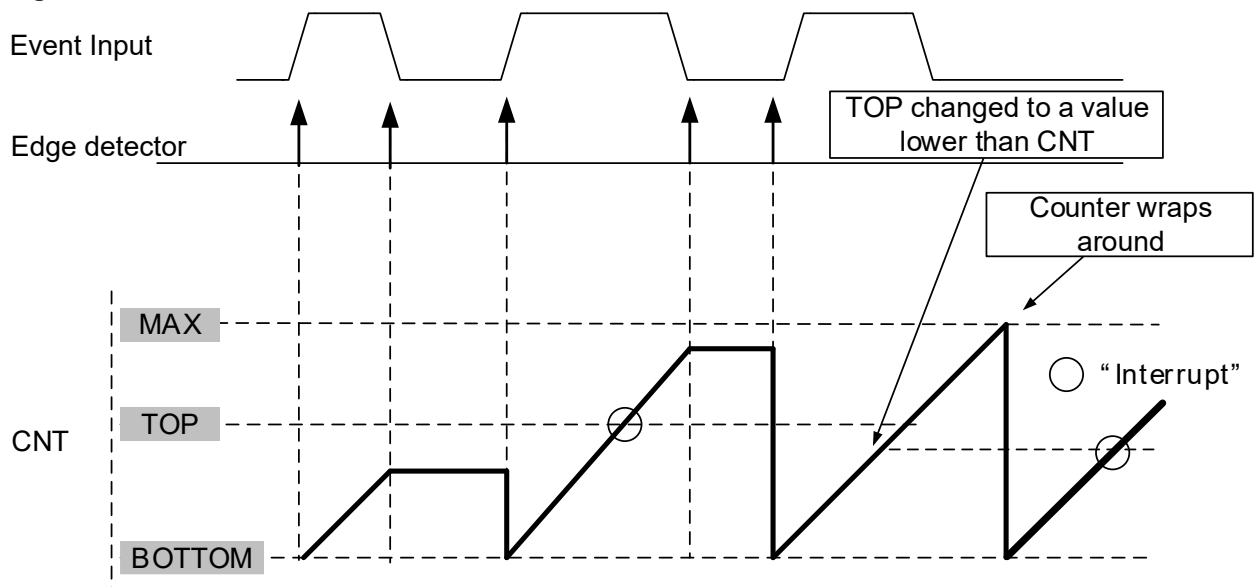
Figure 21-2. Periodic Interrupt Mode



21.3.3.1.2 Time-Out Check Mode

In this mode, the counter counts to MAX and wraps around. On the first edge the counter is restarted and on the second edge, the counter is stopped. If the count register (TCBn.CNT) reaches TOP before the second edge, an interrupt will be generated. In Freeze state, the counter will restart on a new edge. Reading count (TCBn.CNT) or compare/capture (TCBn.CCMP) register, or writing run bit (RUN in TCBn.STATUS) in Freeze state will have no effect.

Figure 21-3. Time-Out Check Mode

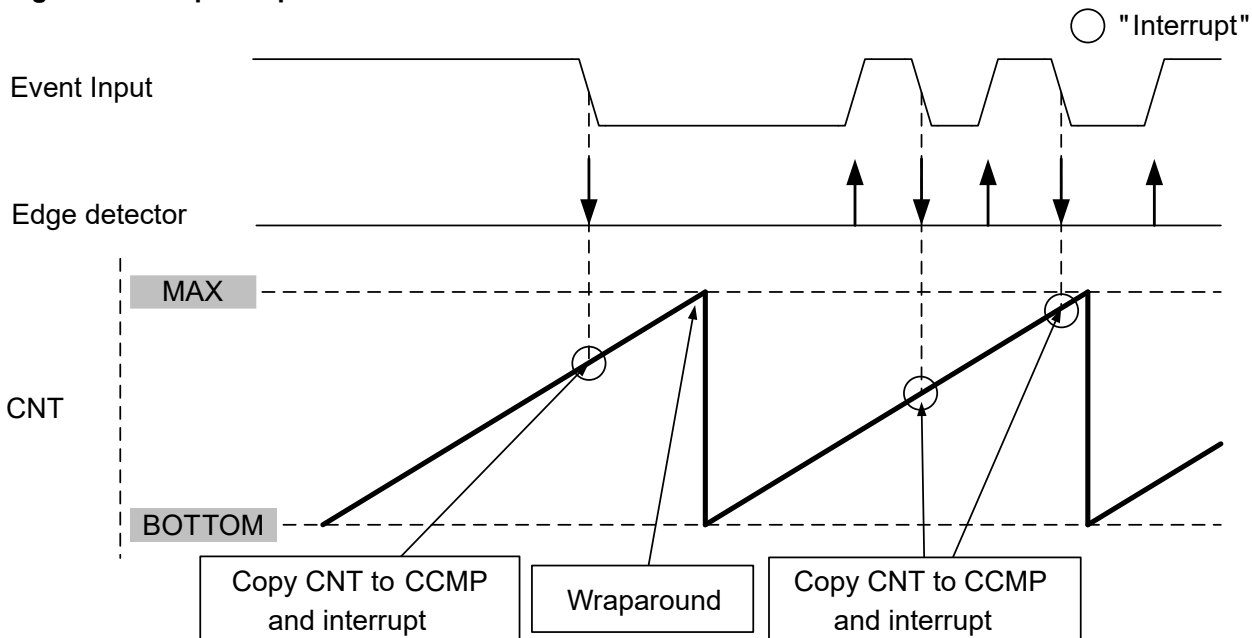


21.3.3.1.3 Input Capture on Event Mode

The counter will count from BOTTOM to MAX continuously. When an event is detected the counter value will be transferred to the Compare/Capture register (TCBn.CCMP) and interrupt is generated. The module has an edge detector that can be configured to trigger count capture on either rising or falling edges.

The figure below shows the input capture unit configured to capture on falling edge on the event input signal. The interrupt flag is automatically cleared after the high byte of the Capture register has been read.

Figure 21-4. Input Capture on Event



It is recommended to write '0' to the TCBn.CNT register when entering this mode from any other mode.

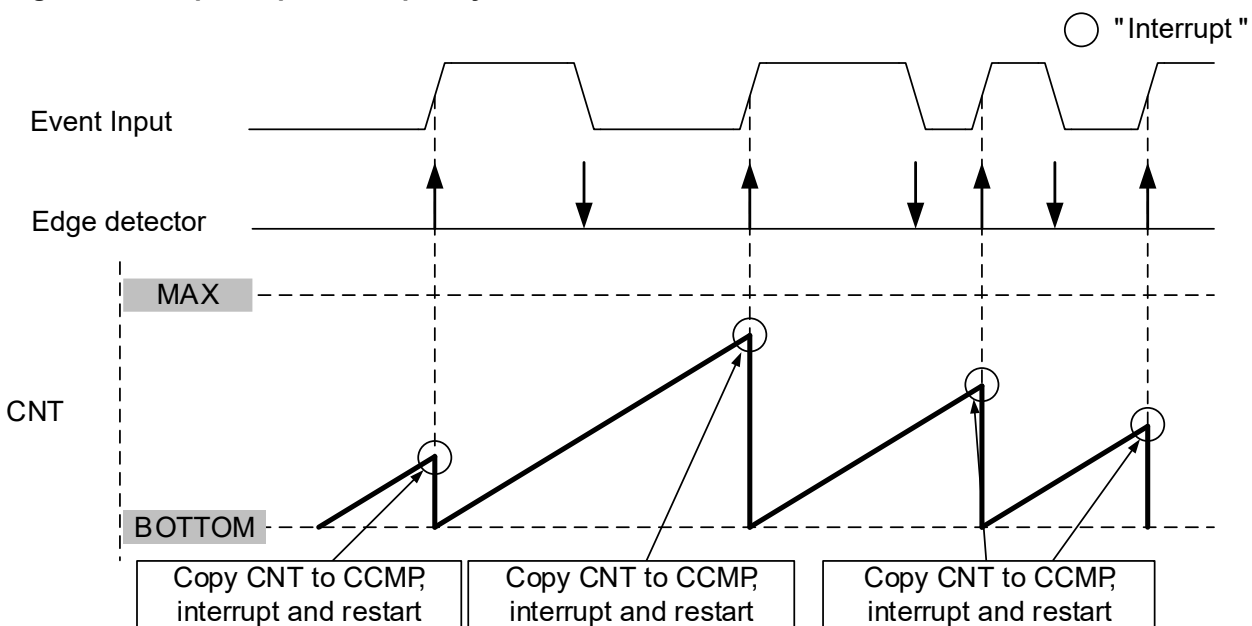
21.3.3.1.4 Input Capture Frequency Measurement Mode

In this mode, the TCB captures the counter value and restarts on either a positive or negative edge of the event input signal.

The interrupt flag is automatically cleared after the high byte of the Compare/Capture register (TCBn.CCMP) has been read, and an interrupt request is generated.

The figure below illustrates this mode when configured to act on rising edge.

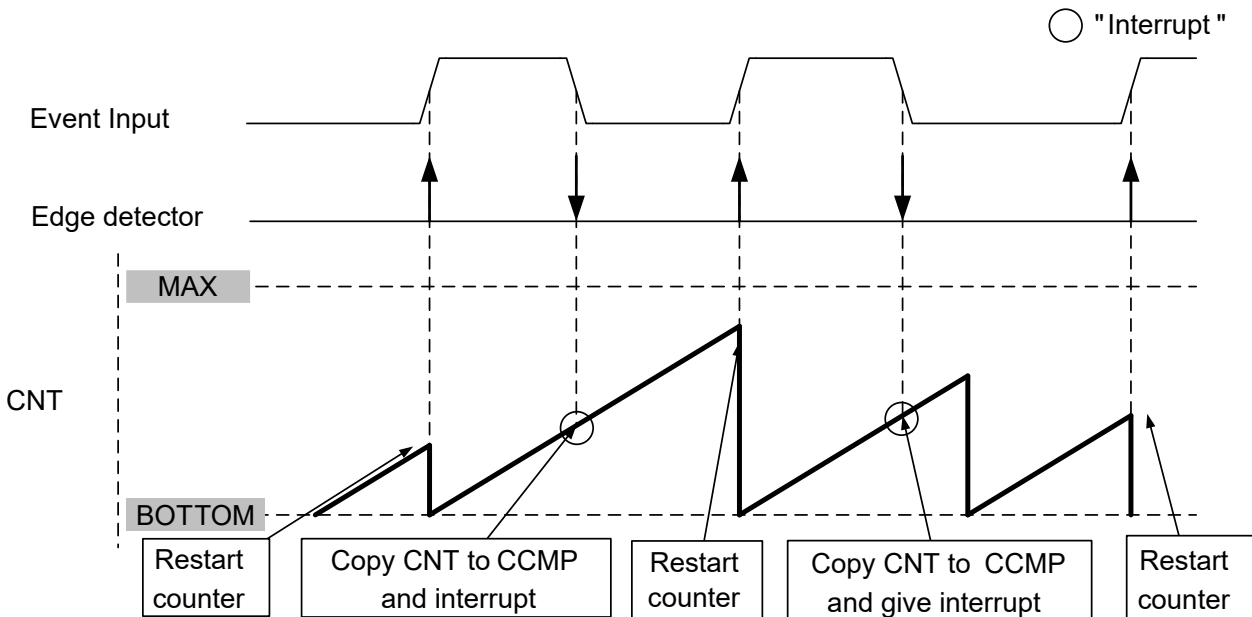
Figure 21-5. Input Capture Frequency Measurement



### 21.3.3.1.5 Input Capture Pulse-Width Measurement Mode

The input capture pulse-width measurement will restart the counter on a positive edge and capture on the next falling edge before an interrupt request is generated. The interrupt flag is automatically cleared when the high byte of the capture register is read. The timer will automatically switch between rising and falling edge detection, but a minimum edge separation of two clock cycles is required for correct behavior.

**Figure 21-6. Input Capture Pulse-Width Measurement**

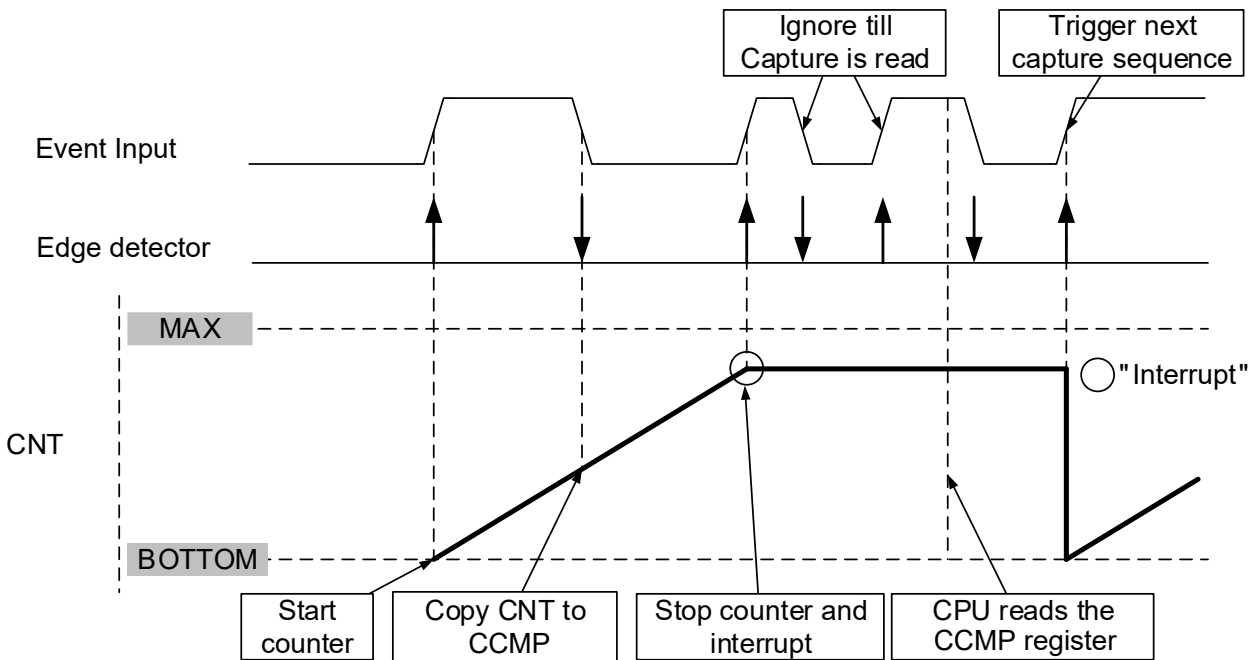


### 21.3.3.1.6 Input Capture Frequency and Pulse-Width Measurement Mode

In this mode, the timer will start counting when a positive edge is detected on the Event Input signal. On the following falling edge, the count value is captured. The counter stops when the second rising edge of the Event Input signal is detected and this will set the interrupt flag.

Reading the capture will clear the interrupt flag. When the capture register is read or the interrupt flag is cleared the TC is ready for a new capture sequence. Therefore, read the counter register before the capture register since it is reset to zero at the next positive edge.

**Figure 21-7. Input Capture Frequency and Pulse-Width Measurement**



### 21.3.3.1.7 Single-Shot Mode

This mode can be used to generate a pulse with a duration that is defined by the Compare register (TCBn.CCMP), every time a rising or falling edge is observed on a connected event channel.

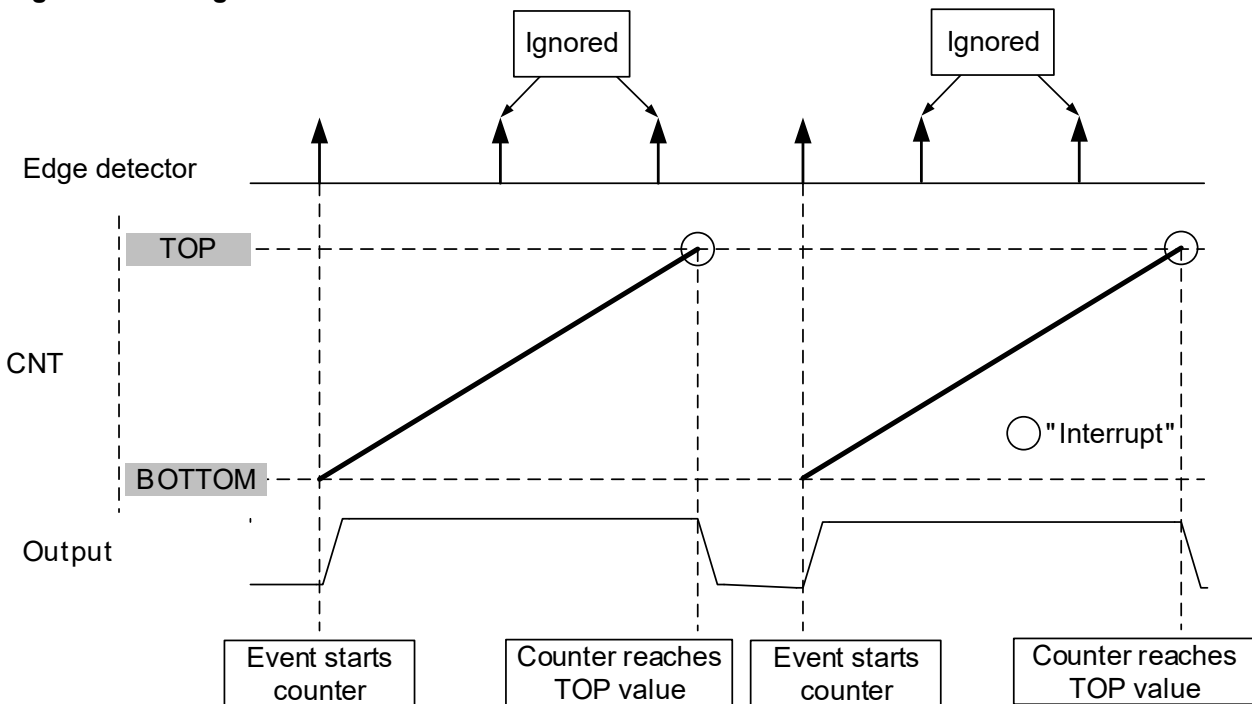
When the counter is stopped, the output pin is driven to low. If an event is detected on the connected event channel, the timer will reset and start counting from zero to TOP while driving its output high. The RUN bit in the STATUS register can be read to see if the counter is counting or not. When the counter register reaches the CCMP register value, the counter will stop and the output pin will go low for at least one prescaler cycle. If a new event arrives during this time, that event will be ignored. The following figure shows an example waveform. There is a two clock cycle delay from when the event is received until the output is set high.

The counter will start counting as soon as the module is enabled, even without triggering an event. This is prevented by writing TOP to the counter register. Similar behavior is seen if the EDGE bit in the TCBn.EVCTRL register is '1' while the module is enabled. Writing TOP to the Counter register prevents this as well.

If the ASYNC bit in TCBn.CTRLB is written to '1', the timer is reacting asynchronously to an incoming event. An edge on the event will immediately cause the output signal to be set. The counter will still start counting two clock cycles after the event is received.



Figure 21-8. Single-Shot Mode



#### 21.3.3.1.8 8-Bit PWM Mode

This timer can be configured to run in 8-bit PWM mode where each of the register pairs in the 16-bit Compare/Capture register (TCBn.CCMPH and TCBn.CCMPL) are used as individual compare registers. The counter will continuously count from zero to CCMPL and the output will be set at BOTTOM and cleared when the counter reaches CCMPH.

When this peripheral is enabled and in PWM mode, changing the value of the Compare/Capture register will change the output, but the transition may output invalid values. It is hence recommended to:

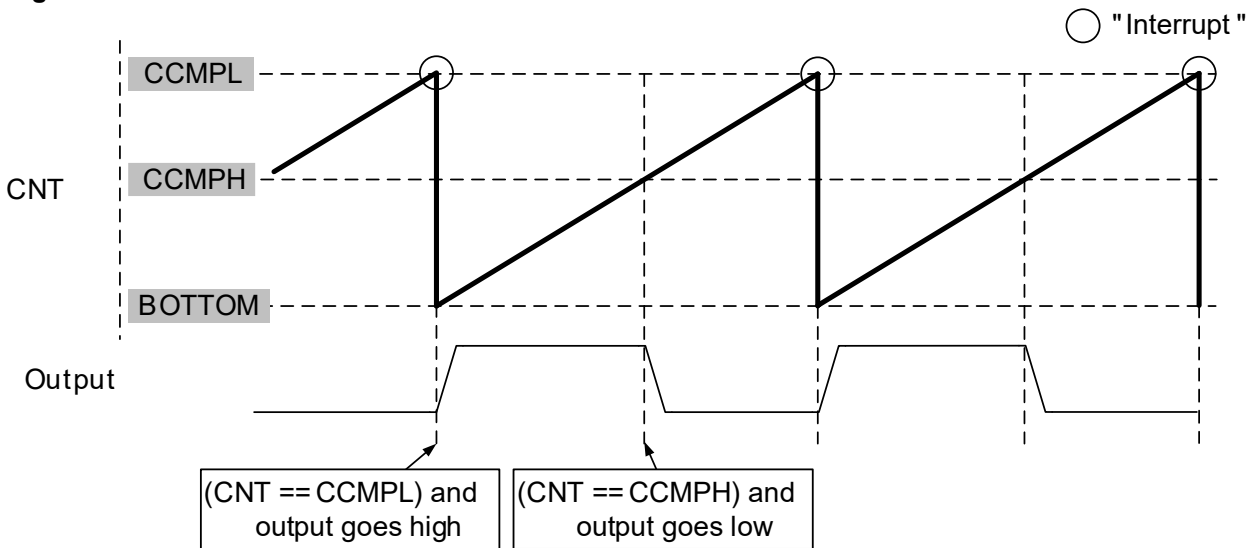
1. Disable the peripheral.
2. Write Compare/Capture register to {CCMPH, CCMPL}.
3. Write 0x0000 to count register.
4. Re-enable the module.

CCMPH is the number of cycles for which the output will be driven high, CCMPL+1 is the period of the output pulse.

For different capture register values the output values are:

- $CCMPL = 0 \Rightarrow \text{Output} = 0$
- $CCMPL = 0xFF$ 
  - $CCMPH = 0 \Rightarrow \text{Output} = 0$
  - $0 < CCMPH \leq 0xFF \Rightarrow \text{Output} = 1$  for CCMPH cycles, low for the rest of the period
- For  $0 < CCMPL < 0xFF$ 
  - $CCMPH = 0 \Rightarrow \text{Output} = 0$
  - If  $0 < CCMPH \leq CCMPL \Rightarrow \text{Output} = 1$  for CCMPH cycles, low for the rest of the period
  - $CCMPH = CCMPL + 1 \Rightarrow \text{Output} = 1$

**Figure 21-9. 8-Bit PWM Mode**



### 21.3.3.2 Output

If ASYNC in TCBn.CTRLB is written to '0' ('1'), the output pin is driven synchronously (asynchronously) to the TCB clock. The CCMPINIT, CCMPEN, and CNTMODE bits in TCBn.CTRLB control how the synchronous output is driven. The different configurations and their impact on the output are listed in the table below.

**Table 21-3. Synchronous Output**

CNTMODE	Output, CTRLB='0', CCMPEN=1	Output, CTRLB='1', CCMPEN=1
Single-Shot mode	Output high when the counter starts and output low when the counter stops	Output high when event arrives and output low when the counter stops
8-bit PWM mode	PWM mode output	PWM mode output
Modes except single shot and PWM	Bit CCMPINIT in TCBn.CTRLB	Bit CCMPINIT in TCBn.CTRLB

### 21.3.3.3 Noise Canceler

The noise canceler improves noise immunity by using a simple digital filter scheme. When the noise filter is enabled, the peripheral monitors the event channel and keeps a record of the last four observed samples. If four consecutive samples are equal, the input is considered to be stable and the signal is fed to the edge detector.

When enabled, the noise canceler introduces an additional delay of four system clock cycles between a change applied to the input and the update of the input compare register.

The noise canceler uses the system clock and is, therefore, not affected by the prescaler.

### 21.3.3.4 Synchronized with TCAn

TCB can be configured to use the clock (CLK\_TCA) of the Timer/Counter type A (TCAn) by writing to the Clock Select bit field (CLKSEL) in the Control A register (TCBn.CTRLA). In this setting, the TCB will count on the exact same clock source as selected in TCA.

When the Synchronize Update bit (SYNCUPD) in the Control A register (TCBn.CTRLA) is written to '1', the TCB counter will restart when the TCA counter restarts.

### Related Links

[21.2.1 Block Diagram](#)

### 21.3.4 Events

The TCB is an event generator. Any condition that causes the CAPT flag in TCBn.INTFLAGS to be set will also generate a one-cycle strobe on the event channel output.

The peripheral accepts one event input. If the Capture Event Input Enable bit (CAPTEI) in the Event Control register (TCBn.EVCTRL) is written to '1', incoming events will result in an event action as defined by the Event Edge bit (EDGE) in TCBn.EVCTRL. The event needs to last for at least one CLK\_PER cycle to ensure that it is recognized.

If the Asynchronous mode is enabled for Single-Shot mode, the event is edge triggered and will capture changes on the event input shorter than one system clock cycle.

### Related Links

[21.5.3 EVCTRL](#)

[14. EVSYS - Event System](#)

### 21.3.5 Interrupts

**Table 21-4. Available Interrupt Vectors and Sources**

Offset	Name	Vector Description	Conditions
0x00	CAPT	TCB interrupt	Depending on operating mode. See description of CAPT in TCB.INTFLAG.

When an interrupt condition occurs, the corresponding interrupt flag is set in the Interrupt Flags register of the peripheral (*peripheral*.INTFLAGS).

An interrupt source is enabled or disabled by writing to the corresponding enable bit in the peripheral's Interrupt Control register (*peripheral*.INTCTRL).

An interrupt request is generated when the corresponding interrupt source is enabled and the interrupt flag is set. The interrupt request remains active until the interrupt flag is cleared. See the peripheral's INTFLAGS register for details on how to clear interrupt flags.

### Related Links

[13. CPUINT - CPU Interrupt Controller](#)

[21.5.5 INTFLAGS](#)

### 21.3.6 Sleep Mode Operation

TCB will halt operation in the Power-Down Sleep mode. Standby sleep operation is dependent on the Run in Standby bit (RUNSTDBY) in the Control A register (TCB.CTRLA).

### 21.3.7 Synchronization

Not applicable.

### 21.3.8 Configuration Change Protection

Not applicable.

### 21.4 Register Summary - TCB

Offset	Name	Bit Pos.							
0x00	<a href="#">CTRLA</a>	7:0		RUNSTDBY		SYNCUPD		CLKSEL[1:0]	ENABLE
0x01	<a href="#">CTRLB</a>	7:0		ASYNC	CCMPINIT	CCMPEN		CNTMODE[2:0]	
0x02	Reserved								
0x03									
0x04	<a href="#">EVCTRL</a>	7:0		FILTER		EDGE			CAPTEI
0x05	<a href="#">INTCTRL</a>	7:0							CAPT
0x06	<a href="#">INTFLAGS</a>	7:0							CAPT
0x07	<a href="#">STATUS</a>	7:0							RUN
0x08	<a href="#">DBGCTRL</a>	7:0							DBGRUN
0x09	<a href="#">TEMP</a>	7:0	TEMP[7:0]						
0x0A	<a href="#">CNT</a>	7:0	CNT[7:0]						
		15:8	CNT[15:8]						
0x0C	<a href="#">CCMP</a>	7:0	CCMP[7:0]						
		15:8	CCMP[15:8]						

### 21.5 Register Description

### 21.5.1 Control A

**Name:** CTRLA  
**Offset:** 0x00  
**Reset:** 0x00  
**Property:** -

Bit	7	6	5	4	3	2	1	0
		RUNSTDBY		SYNCUPD		CLKSEL[1:0]		ENABLE
Access		R/W		R/W		R/W	R/W	R/W
Reset		0		0		0	0	0

#### Bit 6 – RUNSTDBY Run in Standby

Writing a '1' to this bit will enable the peripheral to run in Standby Sleep mode. Not applicable when CLKSEL is set to 0x2 (CLK\_TCA).

#### Bit 4 – SYNCUPD Synchronize Update

When this bit is written to '1', the TCB will restart whenever the TCA0 counter is restarted.

#### Bits 2:1 – CLKSEL[1:0] Clock Select

Writing these bits selects the clock source for this peripheral.

Value	Description
0x0	CLK_PER
0x1	CLK_PER/2
0x2	Use CLK_TCA from TCA0
0x3	Reserved

#### Bit 0 – ENABLE Enable

Writing this bit to '1' enables the Timer/Counter type B peripheral.

### 21.5.2 Control B

**Name:** CTRLB  
**Offset:** 0x01  
**Reset:** 0x00  
**Property:** -

Bit	7	6	5	4	3	2	1	0
		ASYNC	CCMPINIT	CCMPEN		CNTMODE[2:0]		
Access		R/W	R/W	R/W		R/W	R/W	R/W
Reset		0	0	0		0	0	0

#### Bit 6 – ASYNC Asynchronous Enable

Writing this bit to '1' allows asynchronous updates of the TCB output signal in Single-Shot mode.

Value	Description
0	The output will go HIGH when the counter actually starts
1	The output will go HIGH when an event arrives

#### Bit 5 – CCMPINIT Compare/Capture Pin Initial Value

This bit is used to set the initial output value of the pin when a pin output is used.

Value	Description
0	Initial pin state is LOW
1	Initial pin state is HIGH

#### Bit 4 – CCMPEN Compare/Capture Output Enable

This bit is used to enable the output signal of the Compare/Capture.

Value	Description
0	Compare/Capture Output is zero
1	Compare/Capture Output has a valid value

#### Bits 2:0 – CNTMODE[2:0] Timer Mode

Writing these bits selects the Timer mode.

Value	Description
0x0	Periodic Interrupt mode
0x1	Time-out Check mode
0x2	Input Capture on Event mode
0x3	Input Capture Frequency Measurement mode
0x4	Input Capture Pulse-Width Measurement mode
0x5	Input Capture Frequency and Pulse-Width Measurement mode
0x6	Single-Shot mode
0x7	8-Bit PWM mode

### 21.5.3 Event Control

**Name:** EVCTRL  
**Offset:** 0x04  
**Reset:** 0x00  
**Property:** -

Bit	7	6	5	4	3	2	1	0
		FILTER		EDGE				CAPTEI
Access		R/W		R/W				R/W
Reset		0		0				0

#### Bit 6 – FILTER Input Capture Noise Cancellation Filter

Writing this bit to '1' enables the input capture noise cancellation unit.

#### Bit 4 – EDGE Event Edge

This bit is used to select the event edge. The effect of this bit is dependent on the selected Count Mode (CNTMODE) in TCBn.CTRLB. "-" means that an event or edge has no effect in this mode.

Count Mode	EDGE	Positive Edge	Negative Edge
Periodic Interrupt mode	0	-	-
	1	-	-
Timeout Check mode	0	Start counter	Stop counter
	1	Stop counter	Start counter
Input Capture on Event mode	0	Input Capture, interrupt	-
	1	-	Input Capture, interrupt
Input Capture Frequency Measurement mode	0	Input Capture, clear and restart counter, interrupt	-
	1	-	Input Capture, clear and restart counter, interrupt
Input Capture Pulse-Width Measurement mode	0	Clear and restart counter	Input Capture, interrupt
	1	Input Capture, interrupt	Clear and restart counter
Input Capture Frequency and Pulse-Width Measurement mode	0	On 1 <sup>st</sup> Positive: Clear and restart counter On following Negative: Input Capture 2 <sup>nd</sup> Positive: Stop counter, interrupt	
	1	On 1 <sup>st</sup> Negative: Clear and restart counter On following Positive: Input Capture 2 <sup>nd</sup> Negative: Stop counter, interrupt	
Single-Shot mode	0	Start counter	-

Count Mode	EDGE	Positive Edge	Negative Edge
	1	Start counter	Start counter
8-Bit PWM mode	0	-	-
	1	-	-

**Bit 0 – CAPTEI** Capture Event Input Enable

Writing this bit to '1' enables the input capture event.



### 21.5.4 Interrupt Control

**Name:** INTCTRL  
**Offset:** 0x05  
**Reset:** 0x00  
**Property:** -

Bit	7	6	5	4	3	2	1	0
								CAPT
Access								R/W
Reset								0

**Bit 0 – CAPT** Capture Interrupt Enable

Writing this bit to '1' enables the capture interrupt.

### 21.5.5 Interrupt Flags

**Name:** INTFLAGS  
**Offset:** 0x06  
**Reset:** 0x00  
**Property:** -

Bit	7	6	5	4	3	2	1	0
								CAPT
Access								R/W
Reset								0

#### Bit 0 – CAPT Interrupt Flag

This bit is set when an interrupt occurs. The interrupt conditions are dependent on the Counter Mode (CNTMODE) in TCBn.CTRLB.

This bit is cleared by writing a '1' to it or when the Capture register is read in Capture mode.

Counter Mode	Interrupt Flag Behavior
Periodic Interrupt mode	Set when the counter reaches TOP
Timeout Check mode	Set when the counter reaches TOP
Input Capture on Event mode	Set when an event occurs and the Capture register is loaded, cleared when Capture is read
Input Capture Frequency Measurement mode	Set on an edge when the Capture register is loaded and count initialized, cleared when Capture is read
Input Capture Pulse-Width Measurement mode	Set on an edge when the Capture register is loaded, the previous edge initialized the count, cleared when Capture is read
Input Capture Frequency and Pulse-Width Measurement mode	Set on second (positive or negative) edge when the counter is stopped, cleared when Capture is read
Single-Shot mode	Set when the counter reaches TOP
8-Bit PWM mode	Set when the counter reaches CCMPL

### 21.5.6 Status

**Name:** STATUS  
**Offset:** 0x07  
**Reset:** 0x00  
**Property:** -

Bit	7	6	5	4	3	2	1	0
								RUN
Access								R
Reset								0

#### Bit 0 – RUN Run

When the counter is running, this bit is set to '1'. When the counter is stopped, this bit is cleared to '0'.

The bit is read-only and cannot be set by UPDI.

### 21.5.7 Debug Control

**Name:** DBGCTRL  
**Offset:** 0x08  
**Reset:** 0x00  
**Property:** -

Bit	7	6	5	4	3	2	1	0
								DBGRUN
Access								R/W
Reset								0

#### Bit 0 – DBGRUN Debug Run

Value	Description
0	The peripheral is halted in Break Debug mode and ignores events
1	The peripheral will continue to run in Break Debug mode when the CPU is halted

### 21.5.8 Temporary Value

**Name:** TEMP  
**Offset:** 0x09  
**Reset:** 0x00  
**Property:** -

The Temporary register is used by the CPU for single-cycle, 16-bit access to the 16-bit registers of this peripheral. It can be read and written by software. Refer to 16-bit access in the AVR CPU chapter. There is one common Temporary register for all the 16-bit registers of this peripheral.

Bit	7	6	5	4	3	2	1	0
	TEMP[7:0]							
Access	R/W	R/W	R/W	R/W	R/W	R/W	R/W	R/W
Reset	0	0	0	0	0	0	0	0

**Bits 7:0 – TEMP[7:0]** Temporary Value

### 21.5.9 Count

**Name:** CNT  
**Offset:** 0x0A  
**Reset:** 0x00  
**Property:** -

The TCBn.CNTL and TCBn.CNTH register pair represents the 16-bit value TCBn.CNT. The low byte [7:0] (suffix L) is accessible at the original offset. The high byte [15:8] (suffix H) can be accessed at offset + 0x01.

CPU and UPDI write access has priority over internal updates of the register.

Bit	15	14	13	12	11	10	9	8
	CNT[15:8]							
Access	R/W	R/W	R/W	R/W	R/W	R/W	R/W	R/W
Reset	0	0	0	0	0	0	0	0
Bit	7	6	5	4	3	2	1	0
	CNT[7:0]							
Access	R/W	R/W	R/W	R/W	R/W	R/W	R/W	R/W
Reset	0	0	0	0	0	0	0	0

#### Bits 15:8 – CNT[15:8] Count Value High

These bits hold the MSB of the 16-bit Counter register.

#### Bits 7:0 – CNT[7:0] Count Value Low

These bits hold the LSB of the 16-bit Counter register.

### 21.5.10 Capture/Compare

**Name:** CCMP  
**Offset:** 0x0C  
**Reset:** 0x00  
**Property:** -

The TCBn.CCMPL and TCBn.CCMPH register pair represents the 16-bit value TCBn.CCMP. The low byte [7:0] (suffix L) is accessible at the original offset. The high byte [15:8] (suffix H) can be accessed at offset + 0x01.

This register has different functions depending on the mode of operation:

- For capture operation, these registers contain the captured value of the counter at the time the capture occurs
- In periodic interrupt/time-out and Single-Shot mode, this register acts as the TOP value
- In 8-bit PWM mode, TCBn.CCMPL and TCBn.CCMPH act as two independent registers

Bit	15	14	13	12	11	10	9	8
	CCMP[15:8]							
Access	R/W	R/W	R/W	R/W	R/W	R/W	R/W	R/W
Reset	0	0	0	0	0	0	0	0
Bit	7	6	5	4	3	2	1	0
	CCMP[7:0]							
Access	R/W	R/W	R/W	R/W	R/W	R/W	R/W	R/W
Reset	0	0	0	0	0	0	0	0

#### Bits 15:8 – CCMP[15:8] Capture/Compare Value High Byte

These bits hold the MSB of the 16-bit compare, capture, and top value.

#### Bits 7:0 – CCMP[7:0] Capture/Compare Value Low Byte

These bits hold the LSB of the 16-bit compare, capture, and top value.

## 22. TCD - 12-Bit Timer/Counter Type D

### 22.1 Features

- 12-bit Timer/Counter
- Programmable Prescaler
- Double-Buffered Compare Registers
- Waveform Generation:
  - One Ramp mode
  - Two Ramp mode
  - Four Ramp mode
  - Dual-Slope mode
- Two Separate Input Capture, Double-Buffered
- Connection to Event System by Programmable Filter
- Conditional Waveform on External Events:
  - Fault handling
  - Input blanking
  - Overload protection function
  - Fast emergency stop by hardware
- Supports Both Half Bridge and Full Bridge Output

### 22.2 Overview

The Timer/Counter type D (TCD) is a high-performance waveform controller that consists of an asynchronous counter, a prescaler, compare logic, capture logic, and control logic. The purpose of the TCD is to control power applications like LED, motor control, H-bridge, and power converters.

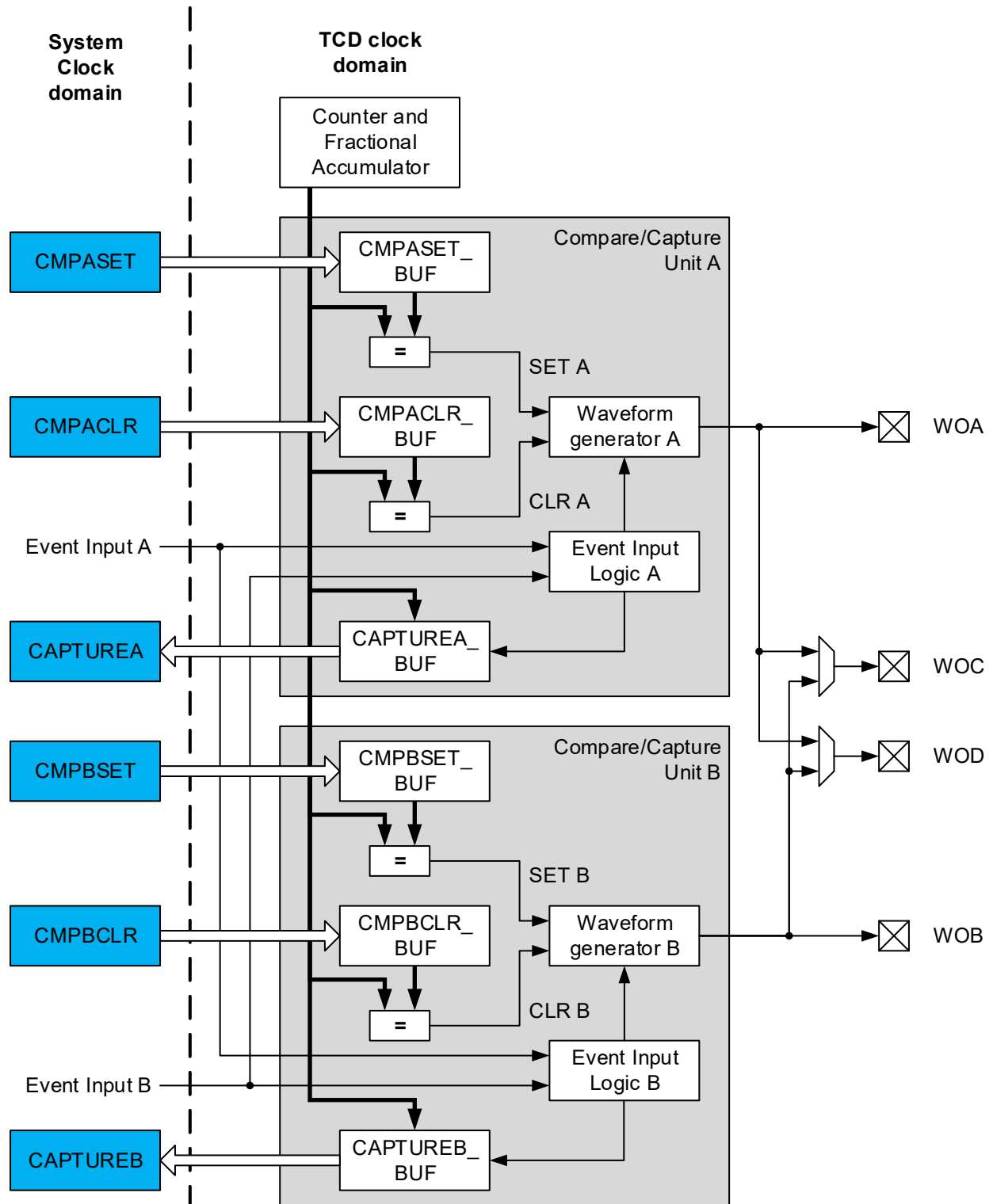
The TCD contains a counter that can run on a clock which is asynchronous from the system clock. It contains compare logic that can generate two independent outputs with optional dead time. It is connected to the event system for capture and deterministic fault control. The timer/counter can generate interrupts and events on compare match and overflow.

This device provides one instance of the TCD peripheral, TCD0.



22.2.1 Block Diagram

Figure 22-1. Timer/Counter Block Diagram



The TCD core is asynchronous to the system clock. The timer/counter consist of two compare/capture units, each with a separate waveform output. In addition, there are two extra waveform outputs which can be equal to the output from one of the units. The compare registers CMPxSET and CMPxCLR are stored

in the respective registers (TCDn.CMPxSET, TCDn.CMPxCLR), which consists of both a low and a high byte. The registers are synchronized to the TCD domain after writing to the registers.

During normal operation, the counter value is continuously compared to the compare registers. This is used to generate both interrupts and events.

The TCD can use the input events in ten different input modes, selected separately for the two input events. The input mode defines how the input event will affect the outputs, and where in the TCD cycle the counter should go when an event occurs.

### 22.2.2 Signal Description

Signal	Description	Type
WOA	TCD waveform output A	Digital output
WOB	TCD waveform output B	Digital output
WOC	TCD waveform output C	Digital output
WOD	TCD waveform output D	Digital output

### 22.2.3 System Dependencies

In order to use this peripheral, other parts of the system must be configured correctly, as described below.

**Table 22-1. TCD System Dependencies**

Dependency	Applicable	Peripheral
Clocks	Yes	CLKCTRL
I/O Lines and Connections	Yes	WOA/B
Interrupts	Yes	CPUINT
Events	Yes	EVSYS
Debug	Yes	UPDI

#### Related Links

[22.2.3.1 Clocks](#)

[22.2.3.5 Debug Operation](#)

[22.2.3.3 Interrupts](#)

[22.2.3.4 Events](#)

#### 22.2.3.1 Clocks

The TCD can be connected directly to the internal 16/20 MHz RC Oscillator (OSC20M), to an external clock, or to the system clock. This is configured by the Clock Select bit field (CLKSEL) in the Control A register (TCD.CTRLA).

#### Related Links

[10. CLKCTRL - Clock Controller](#)

#### 22.2.3.2 I/O Lines and Connections

Using the I/O lines of the peripheral requires configuration of the I/O pins.

#### Related Links

[5. I/O Multiplexing and Considerations](#)

[16. PORT - I/O Pin Configuration](#)

### 22.2.3.3 Interrupts

Using the interrupts of this peripheral requires the interrupt controller to be configured first.

#### Related Links

[13. CPUINT - CPU Interrupt Controller](#)

[8.7.3 SREG](#)

[22.3.4 Interrupts](#)

### 22.2.3.4 Events

The events of this peripheral are connected to the Event System.

#### Related Links

[14. EVSYS - Event System](#)

### 22.2.3.5 Debug Operation

When run-time debugging, this peripheral will continue normal operation. Halting the CPU in Debugging mode will halt normal operation of the peripheral.

This peripheral can be forced to operate with halted CPU by writing a '1' to the Debug Run bit (DBGRUN) in the Debug Control register of the peripheral (*peripheral.DBGCTRL*).

When the Fault Detection bit (FAULTDET in TCDn.DBGCTRL) is written to '1' and the CPU is halted in Debug mode, an event/fault is created on both input event channels. These events/faults will last as long as the break and can serve as a safeguard in Debug mode, e.g. by forcing external components OFF.

If the peripheral is configured to require periodical service by the CPU through interrupts or similar, improper operation or data loss may result during halted debugging.

#### Related Links

[33. UPDI - Unified Program and Debug Interface](#)

### 22.2.4 Definitions

The following definitions are used throughout the documentation:

**Table 22-2. Timer/Counter Definitions**

Name	Description
TCD cycle	The sequence of four states that the counter needs to go through before it has returned to the same position.
Input Blanking	Functionality to ignore event input for a programmable time in a selectable part of the TCD cycle.
Asynchronous output control	Allows the Event to override the output instantly when the Event occurs. It is used for handling non-recoverable faults.
One ramp	Counter is reset to zero once during a TCD cycle.
Two ramp	Counter is reset to zero two times during a TCD cycle.
Four ramp	Counter is reset to zero four times during a TCD cycle.
Dual ramp	Counter counts both up and down between zero and selected top value.

### 22.3 Functional Description

#### 22.3.1 Initialization and Disabling

To initialize the TCD:

1. Configure the static registers to the desired functionality.
2. Write desired initial values to the double-buffered registers.
3. Ensure that the Enable Ready bit (ENRDY) in the Status register (TCDn.STATUS) is set to '1'.
4. Enable the TCD by writing a '1' to the ENABLE bit in the Control A register (TCDn.CTRLA).

It is possible to disable the TCD in two different ways:

1. By writing a '0' to ENABLE in TCDn.CTRLA. This disables the TCD instantly when synchronized to the TCD core domain.
2. By writing a '1' to the Disable at End of Cycle Strobe bit (DISEOC) in the Control E register (TCDn.CTRLE). This disables the TCD at the end of the TCD cycle.

The bit fields in the TCDn.CTRLA register are enable-protected, with exception of the ENABLE bit. They can only be written when ENABLE is written to '0' first.

#### Related Links

[22.3.2.1 Register Synchronization Categories](#)

#### 22.3.2 Operation

##### 22.3.2.1 Register Synchronization Categories

Most of the I/O registers need to be synchronized to the asynchronous TCD core clock domain. This is done in different ways for different register categories:

- Command and Enable Control registers
- Double-buffered registers
- Static registers
- Normal I/O and STATUS registers

See [Table 22-3](#) for categorized registers.

#### Command and Enable Registers

Because of synchronization between the clock domains, it is only possible to change the Enable bits while the Enable Ready bit (ENRDY) in the Status register (TCDn.STATUS) is '1'.

The Control E register commands (TCDn.CTRLE) are automatically synchronized to the TCD core domain when the TCD is enabled and as long as no synchronization is ongoing already. Check if the Command Ready bit (CCMDRDY) is '1' in TCDn.STATUS to ensure that it is possible to write a new command. TCDn.CTRLE is a strobe register that will clear itself when the command is done.

The Control E register commands are:

- Synchronize at the end of the TCD cycle: Synchronizes all double-buffered registers to TCD clock domain at the end of the TCD cycle.
- Synchronize: Synchronizes all double-buffered registers to the TCD clock domain when the command is synchronized to the TCD clock domain.
- Restart: Restarts the TCD counter.
- Software Capture A: Capture the TCD counter value to TCDn.CAPTUREA.

- Software Capture B: Capture the TCD counter value to TCDn.CAPTUREB.

### Double-Buffered Registers

The double-buffered registers can be updated in normal I/O writes while TCD is enabled and no synchronization between the two clock domains is ongoing. Check that the CMDRDY bit in TCDn.STATUS is '1' to ensure that it is possible to update the double-buffered I/O registers. The values will be synchronized to the TCD core domain when a synchronization command is sent or when TCD is enabled.

### Static Registers

The static registers are kept static whenever TCD is enabled. This means that these registers must be configured before enabling TCD. It is not possible to write to these registers as long as TCD is enabled. To see if TCD is enabled, check if ENABLE in TCDn.CTRLA is reading '1'.

### Normal I/O and Status Registers

The read-only registers inform about synchronization status and values synchronized from the core domain. The reset of these registers and normal I/O registers are not constrained by any synchronization between the domains.

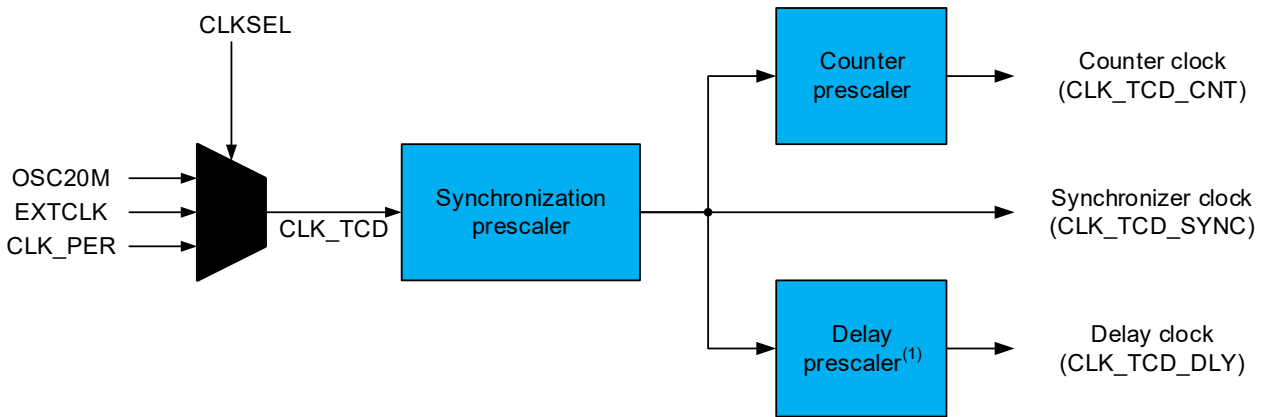
**Table 22-3. Categorization of Registers**

Enable and Command Registers	Double-Buffered Registers	Static Registers	Read-Only Registers	Normal I/O Registers
CTRLA (ENABLE bit)	TCDn.DLYCTRL	TCDn.CTRLA (All bits Except ENABLE bit)	TCDn.STATUS	TCDn.INTCTRL
CTRLE	TCDn.DLYVAL	TCDn.CTRLB	TCDn.CAPTUREA	TCDn.INTFLAGS
	TCDn.DITCTRL	TCDn.CTRLC	TCDn.CAPTUREB	
	TCDn.DITVAL	TCDn.CTRLD		
	TCDn.DBGCTRL	TCDn.EVCTRLA		
	TCDn.CMPASET	TCDn.EVCTRLB		
	TCDn.CMPACLR	TCDn.INPUTCTRLA		
	TCDn.CMPBSET	TCDn.INPUTCTRLB		
	TCDn.CMPBCLR	TCDn.FAULTCTRL		

### 22.3.2.2 Clock Selection and Prescalers

The TCD can select between three different clock sources that can be prescaled. There are three different prescalers with separate controls as shown below.

**Figure 22-2. Clock Selection and Prescalers Overview**



1. Used by input blanking/delay event out

The TCD synchronizer clock is separate from the other module clocks enabling faster synchronization between the TCD domain and the I/O domain. The total prescaling for the counter is:

$$\text{SYNCPRESC\_division\_factor} \times \text{CNTPRESC\_division\_factor}$$

The delay prescaler is used to prescale the clock used for the input blanking/delayed event output functionality. The prescaler can be configured independently allowing separate range and accuracy settings from the counter functionality.

### 22.3.2.3 Waveform Generation Modes

The TCD provides four different Waveform Generation modes. The Waveform Generation modes determine how the counter is counting during a TCD cycle, and when the compare values are matching. A TCD cycle is split into these states:

- Dead time WOA (DTA)
- On time WOA (OTA)
- Dead time WOB (DTB)
- On time WOB (OTB)

In a standard configuration all states are present in the order they are listed and they are non-overlapping. The compare values Compare A Set (CMPASET), Compare A Clear (CMPACLR), Compare B Set (CMPBSET), and Compare B Clear (CMPBCLR) defines when each of the states are ending and the next is beginning. There are four different ways to go through a TCD cycle. The different ways are called Waveform Generation modes. They are controlled by the Waveform Generation Mode bits (WGMODE) in the Control A register (TCDn.CTRLA). The Waveform Generation modes are:

- One Ramp mode
- Two Ramp mode
- Four Ramp mode
- Dual Slope mode

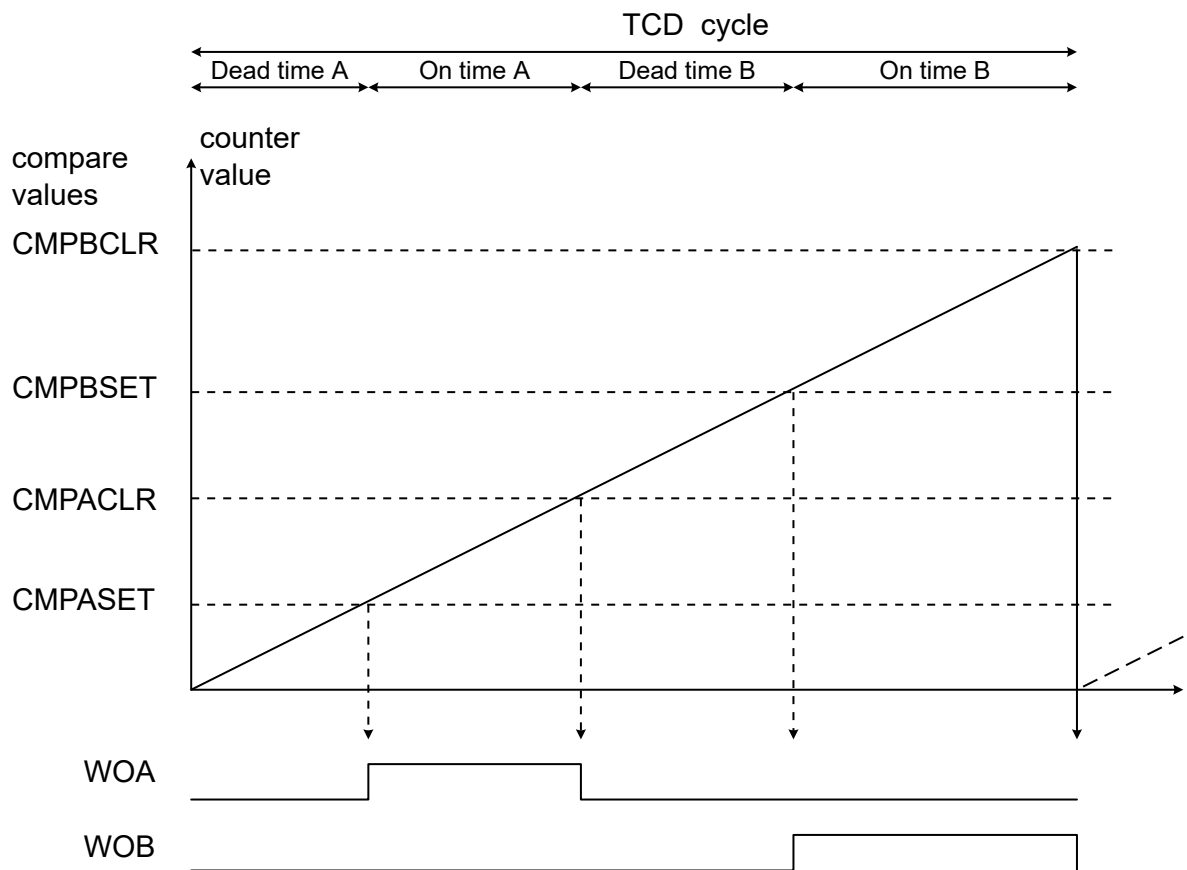
The name indicates how the counter is operating during one TCD cycle.

#### 22.3.2.3.1 One Ramp Mode

In One Ramp mode, the TCD counter counts up until it reaches the CMPBCLR value. Then the TCD cycle is done and the counter restarts from 0x000, beginning a new TCD cycle. The TCD cycle period is:

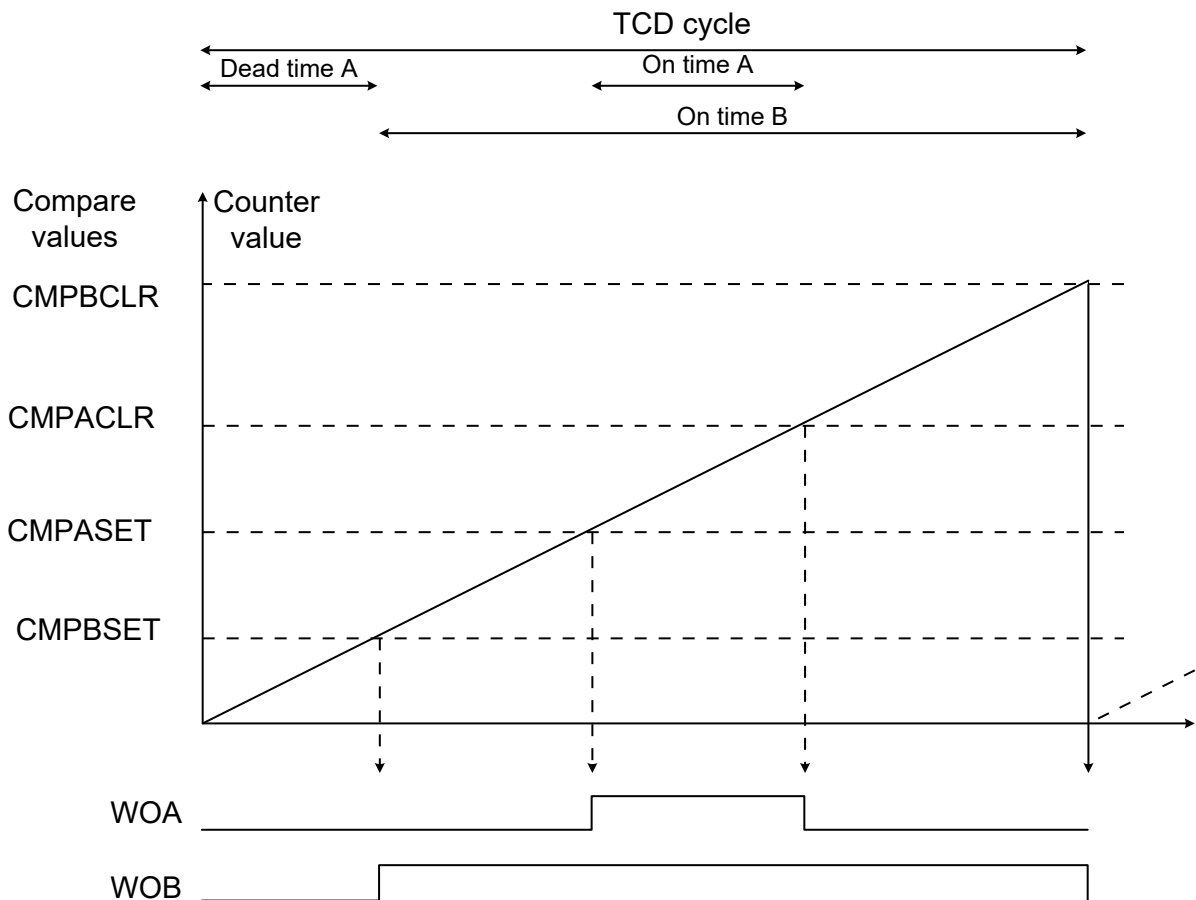
$$T_{\text{TCD\_cycle}} = \frac{\text{CMPBCLR} + 1}{f_{\text{CLK\_TCD\_CNT}}}$$

Figure 22-3. One Ramp Mode



In the figure above,  $CMPASET < CMPACLR < CMPBSET < CMPBCLR$ . This is required in One Ramp mode to avoid overlapping outputs. The figure below is an example where  $CMPBSET < CMPASET < CMPACLR < CMPBCLR$ , resulting in an overlap of the outputs.

Figure 22-4. One Ramp Mode with  $CMPBSET < CMPASET$



If any of the other compare values are bigger than CMPBCLR it will never be triggered when running in One Ramp mode, and if the CMPACL is smaller than the CMPASET value, the clear value will not have any effect.

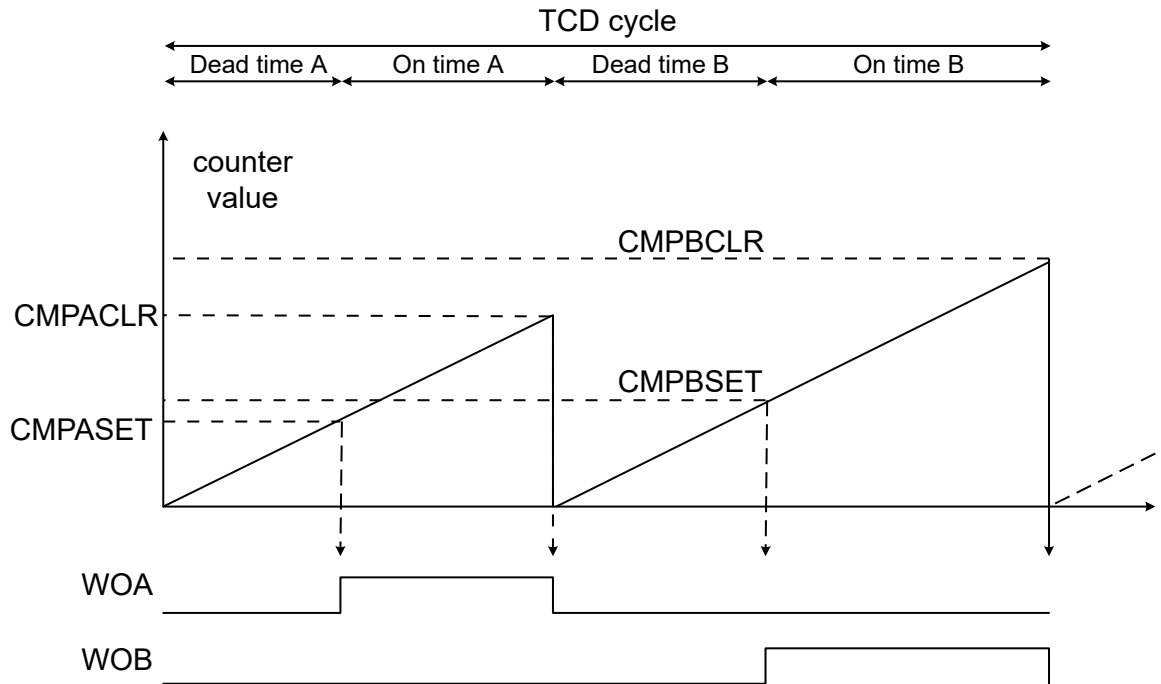
### 22.3.2.3.2 Two Ramp Mode

In Two Ramp mode the TCD counter counts up until it reaches the CMPACL value, then it Resets and counts up until it reaches the CMPBCLR value. Then, the TCD cycle is done and the counter restarts from 0x000, beginning a new TCD cycle. The TCD cycle period is given by:

$$T_{TCD\_cycle} = \frac{(CMPACL + 1 + CMPBCLR + 1)}{f_{CLK\_TCD\_CNT}}$$



**Figure 22-5. Two Ramp Mode**



In the figure above,  $CMPASET < CMPACLR$  and  $CMPBSET < CMPBCLR$ . This causes the outputs to go high. There are no restrictions on the  $CMPASET/CLR$  compared to the  $CMPBSET/CLR$  values.

In Two Ramp mode, it is not possible to get overlapping outputs.

### 22.3.2.3.3 Four Ramp Mode

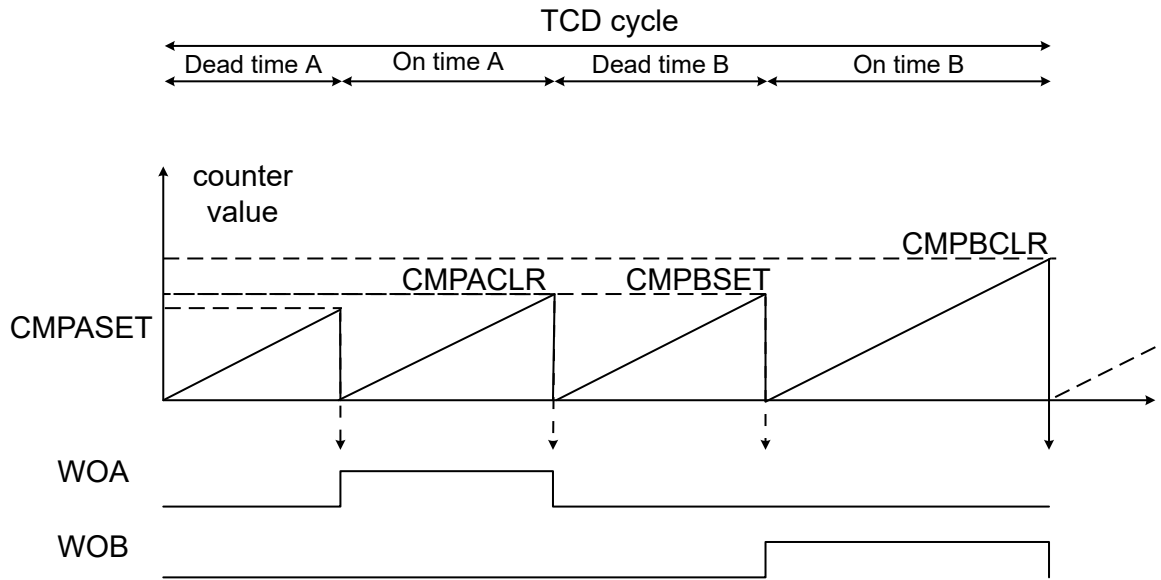
In Four Ramp mode the TCD cycle is following this pattern:

1. A TCD cycle begins with the TCD counter counting up from zero until it reaches the  $CMPASET$  value, and resets to zero.
2. The Counter counts up from zero until it reaches the  $CMPACLR$  value, and resets to zero.
3. The Counter counts up from zero until it reaches the  $CMPBSET$  value, and resets to zero.
4. The Counter counts up from zero until it reaches the  $CMPBCLR$  value, and ends the TCD cycle by resetting to zero.

The TCD cycle period is given by:

$$T_{TCD\_cycle} = \frac{(CMPASET + 1 + CMPACLR + 1 + CMPBSET + 1 + CMPBCLR + 1)}{f_{CLK\_TCD\_CNT}}$$

Figure 22-6. Four Ramp Mode



There are no restrictions on the compare values compared to each other.

In Four Ramp mode, it is not possible to get overlapping outputs.

**22.3.2.3.4 Dual Slope Mode**

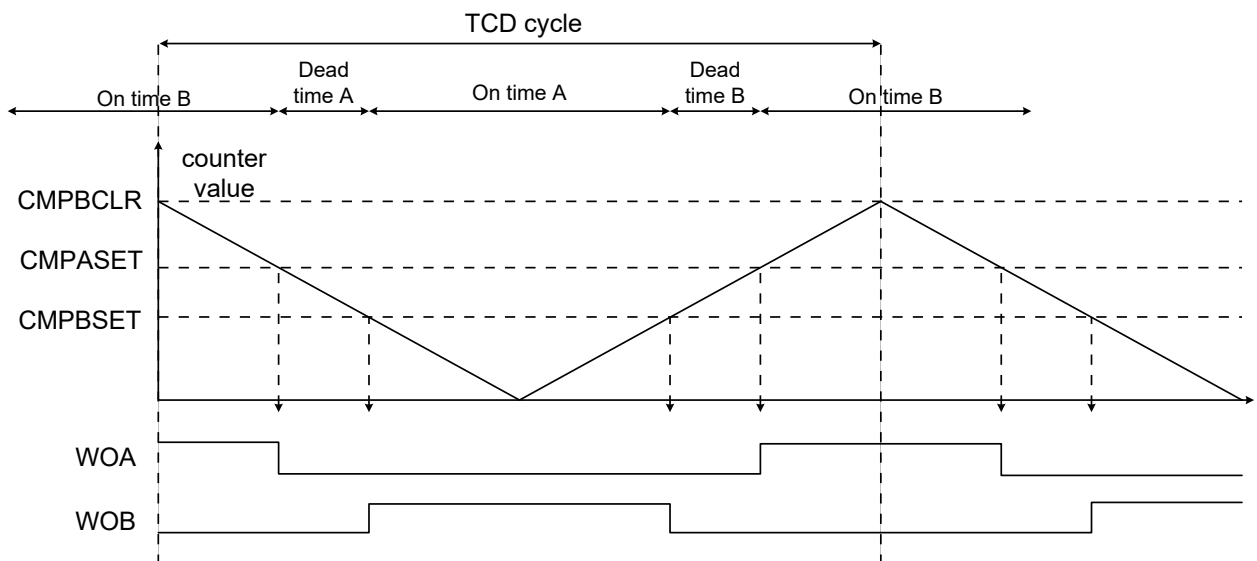
In Dual Slope mode, a TCD cycle consists of the TCD counter counting down from CMPBCLR value to zero, and up again to the CMPBCLR value. This gives a TCD cycle period:

$$T_{TCD\_cycle} = \frac{2 \times (CMPBCLR + 1)}{f_{CLK\_TCD\_CNT}}$$

The WOA output is set when the TCD counter counts up and matches the CMPASET value. WOA is cleared when the TCD counter counts down and matches the CMPASET value.

The WOB output is set when the TCD counter counts down and matches the CMPBSET value. WOB is cleared when the TCD counter counts up and matches the CMPBSET value.

Figure 22-7. Dual Slope Mode

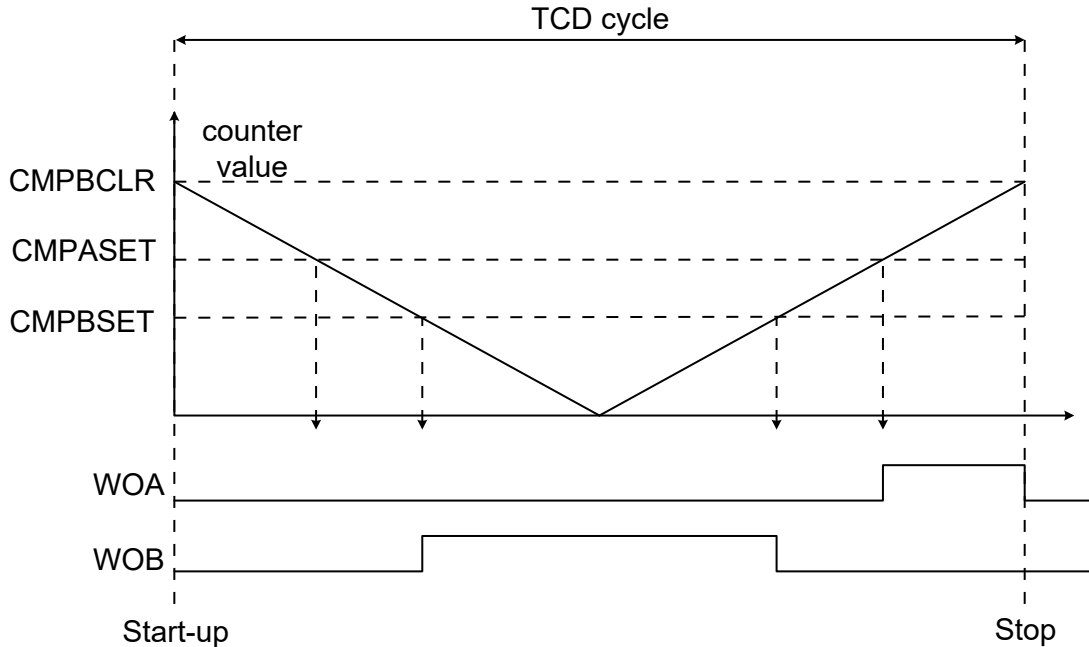


The outputs will be overlapping if CMPBSET > CMPASET.

CMPACLR is not used in Dual Slope mode. Writing a value to CMPACLR has no effect.

When starting the TCD in Dual Slope mode, the TCD counter starts at the CMPBCLR value and counts down. The WOA will not be set before the end of the first TCD cycle.

**Figure 22-8. Dual Slope Mode Starting and Stopping**



### 22.3.2.4 TCD Inputs

The TCD has two inputs that are connected to the Event System, Input A and Input B. Each input has functionality that is connected to the corresponding output (WOA and WOB). That functionality is controlled by the Event Control x registers (TCDn.EVCTRLA and TCDn.EVCTRLB) and the Input Control x registers (TCDn.INPUTACTRL and TCDn.INPUTBCTRL).

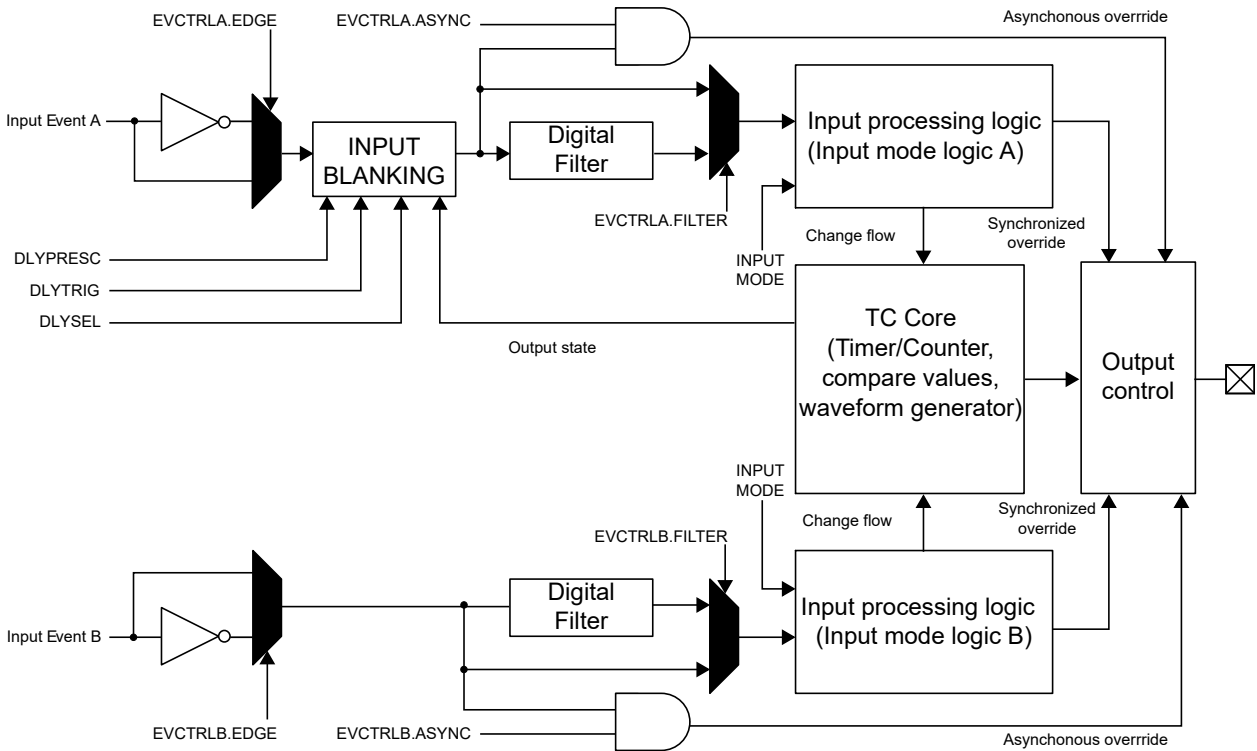
To enable the input Events, write a '1' to the Trigger Event Input Enable bit (TRIGE1) in the Event Control register (TCDn.EVCTRLx). The inputs will be used as a fault detect and/or capture trigger. To enable capture trigger, write a '1' to the ACTION bit in Event Control register (TCDn.EVCTRLx).

There are ten different input modes for the fault detection. The two inputs have the same functionality, except for input blanking which is only supported by input A. Input blanking is configured by the Delay Control and Delay Value registers (TCDn.DLYCTRL and TCDn.DLYVAL).

The inputs are connected to the Event System. The connections between the event source and the TCD input must be configured in the Event System.

An overview of the input system is shown below.

**Figure 22-9. TCD Input Overview**



There is a delay of 2-3 clock cycles on the TCD synchronizer clock between receiving the input event, processing it, and overriding the outputs. If using the asynchronous event detection, the outputs will override instantly outside the input processing.

### 22.3.2.4.1 Input Blanking

Input blanking functionality is masking out the input events for a programmable time in a selectable part of the TCD cycle. Input blanking can be used to mask out 'false' input events that are triggered right after changes on the outputs.

To enable input blanking, write 0x1 to the Delay Select bit field in the Delay Control register (DLYSEL in TCDn.DLYCTRL). The trigger source is selected by the Delay Trigger bit field (DLYTRIG in TCDn.DLYCTRL).

Input blanking uses the Delay clock: after a trigger, a counter is counting up until the Delay Value (DLYVAL in TCDn.DLYVAL) is reached before input blanking is turned OFF. The TCD delay clock is a prescaled version of the Synchronization clock. The division factor is set by the Delay Prescaler bit field in the Delay Control register (DLYPRESC in TCDn.DLYCTRL). The duration of the input blanking is given by:

$$t_{\text{BLANK}} = \frac{\text{DLYPRESC\_division\_factor} \times \text{DLYVAL}}{f_{\text{CLK\_TCD\_SYNC}}}$$

Input blanking is using the same logic as the programmable output event. For this reason, it is not possible to use both at the same time.

### 22.3.2.4.2 Digital Filter

The digital filter for event input x is enabled by writing a '1' to the FILTER bit in the Event Control x register (TCDn.EVCTRLx). When the digital filter is enabled, any pulse lasting less than four counter clock cycles will be filtered out. Any change on the incoming event will, therefore, take four counter clock cycles before it will affect the input processing logic.

### 22.3.2.4.3 Asynchronous Event Detection

To enable asynchronous event detection on an input event, write a '1' to the Asynchronous Event Control bit (ASYNC) in the Event Control register (TCDn.EVCTRLx).

The asynchronous event detection makes it possible to asynchronously override the output when the input event occurs. What the Input event will do is depending on Input Mode for the event input. The outputs have direct override while the counter flow will be changed when the event is synchronized to the synchronization clock.

It is not possible to use both asynchronous event detection and digital filtering at the same time.

### 22.3.2.4.4 Input Modes

The user can select between 10 input modes. The selection is done by writing the Input Mode bit field (INPUTMODE) in the Input Control x register (TCDn.INPUTCTRLx).

**Table 22-4. Input Mode Description**

INPUTMODE	Description
0x0	Input has no action
0x1	Stop output, jump to opposite compare cycle and wait
0x2	Stop output, execute opposite compare cycle and wait
0x3	Stop output, execute opposite compare cycle while fault active
0x4	Stop all outputs, maintain frequency
0x5	Stop all outputs, execute dead time while fault active
0x6	Stop all outputs, jump to next compare cycle and wait
0x7	Stop all outputs, wait for software action
0x8	Stop output on edge, jump to next compare cycle
0x9	Stop output on edge, maintain frequency
0xA	Stop output at level, maintain frequency
other	Reserved

Not all input modes work in all Waveform Generation modes. Below is a table that shows what Waveform Generation modes the different input modes are valid in.

**Table 22-5. Ramp Mode the Different Input Modes are Valid In**

INPUTMODE	One Ramp Mode	Two Ramp Mode	Four Ramp Mode	Dual Slope Mode
0x1	Valid	Valid	Valid	Do not use
0x2	Do not use	Valid	Valid	Do not use
0x3	Do not use	Valid	Valid	Do not use
0x4	Valid	Valid	Valid	Valid
0x5	Do not use	Valid	Valid	Do not use
0x6	Do not use	Valid	Valid	Do not use

INPUTMODE	One Ramp Mode	Two Ramp Mode	Four Ramp Mode	Dual Slope Mode
0x7	Valid	Valid	Valid	Valid
0x8	Valid	Valid	Valid	Do not use
0x9	Valid	Valid	Valid	Do not use
0xA	Valid	Valid	Valid	Do not use

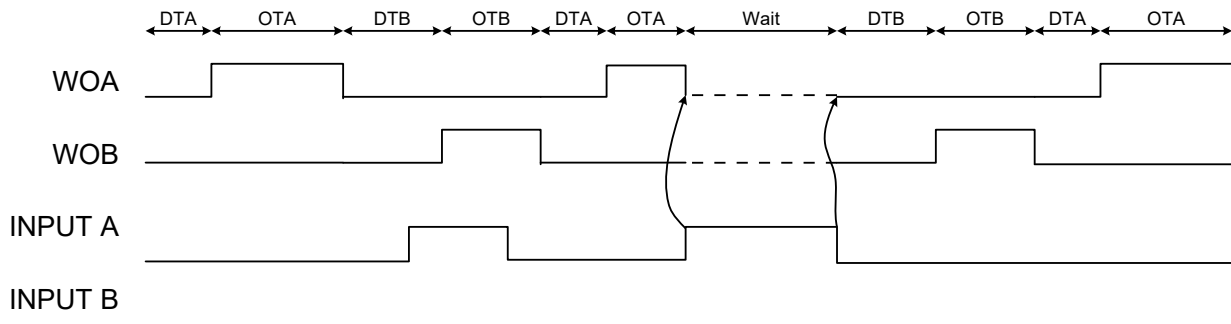
In the following sections the different Input modes are presented in detail.

### **Input Mode 1: Stop Output, Jump to Opposite Compare Cycle, and Wait**

An input Event in Input mode 1 will stop the output signal, jump to the opposite dead time, and wait until the input event goes low before the TCD counter continues.

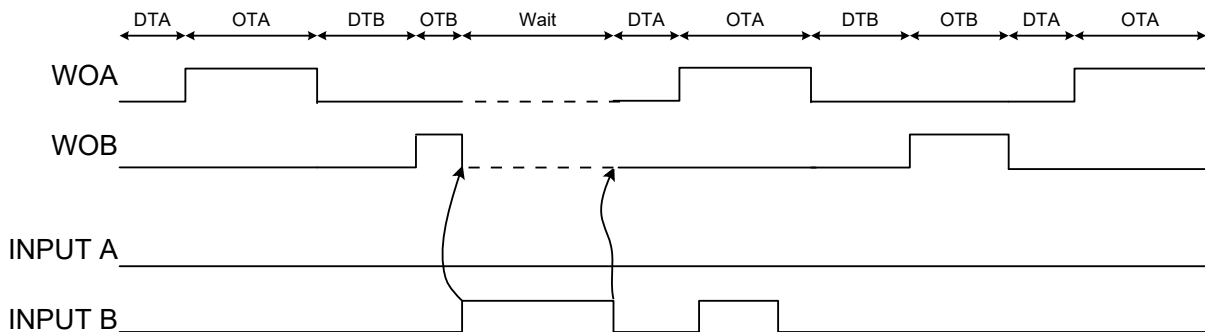
If Input mode 1 is used on input A, an event will only have an effect if the TCD is in Dead-time A or On-time A, and it will only affect the output WOA. When the event is done, the TCD counter starts at Dead-time B.

**Figure 22-10. Input Mode 1 on Input A**



If Input mode 1 is used on input B, an event will only have an effect if the TCD is in Dead-time B or On-time B, and it will only affect the output WOB. When the event is done, the TCD counter starts at Dead-time A.

**Figure 22-11. Input Mode 1 on Input B**

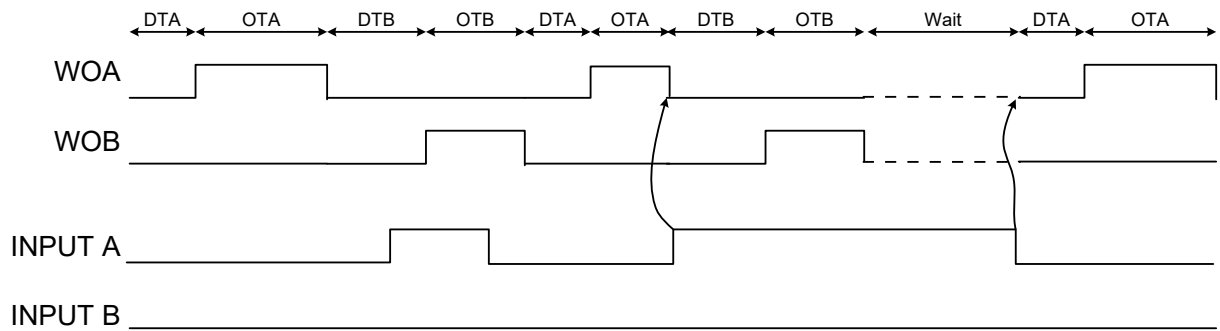


### **Input Mode 2: Stop Output, Execute Opposite Compare Cycle, and Wait**

An input Event in Input mode 2 will stop the output signal, execute to the opposite dead time and on time, then wait until the input event goes low before the TCD counter continues. If the input is done before the opposite dead time and on time have finished, there will be no waiting, but the opposite dead time and on time will continue.

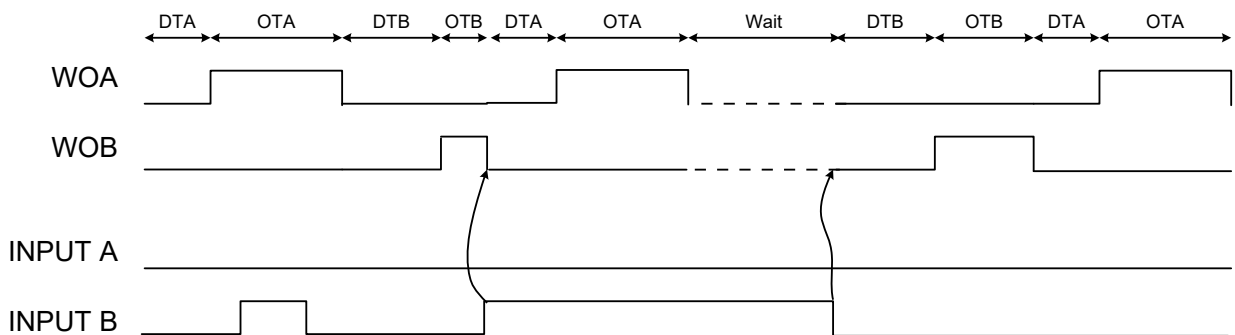
If Input mode 2 is used on input A, an event will only have an effect if the TCD is in Dead-time A or On-time A, and it will only affect the output WOA.

**Figure 22-12. Input Mode 2 on Input A**



If Input mode 2 is used on input B, an event will only have an effect if the TCD is in Dead-time B or On-time B, and it will only affect the output WOB.

**Figure 22-13. Input Mode 2 on Input B**

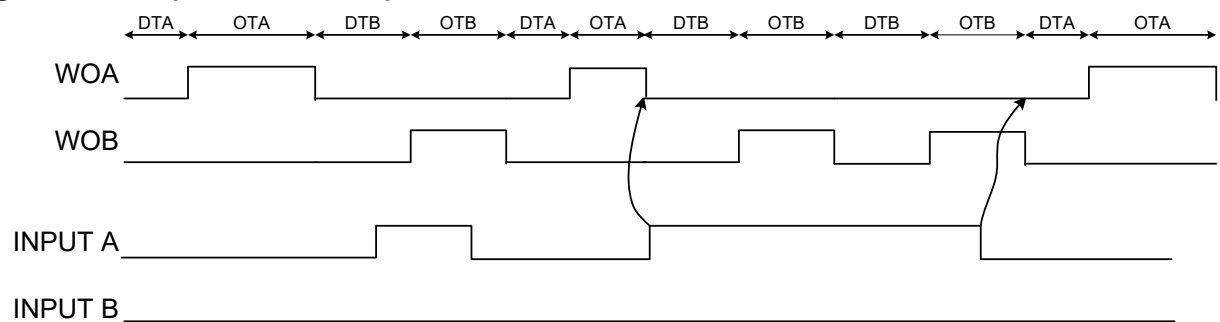


**Input Mode 3: Stop Output, Execute Opposite Compare Cycle while Fault Active**

An input Event in Input mode 3 will stop the output signal and start executing the opposite dead time and on time, as long as the fault/input is active. When the input is released, the ongoing dead time and/or on time will finish and then, the normal flow will start.

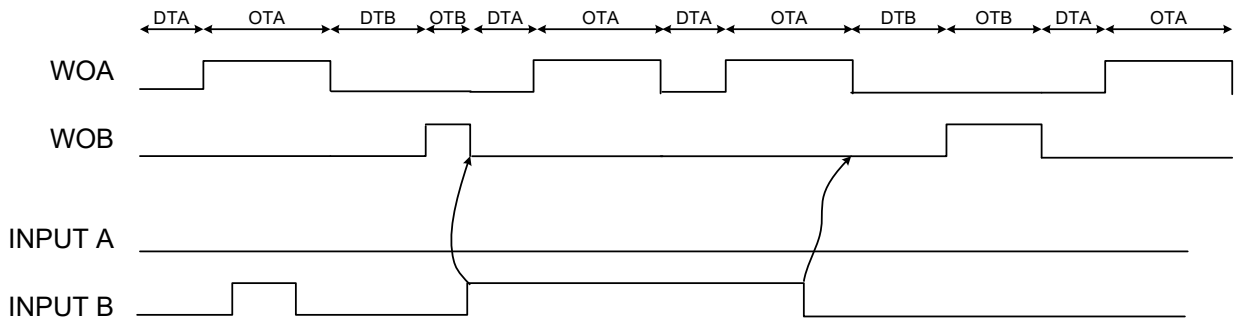
If Input mode 3 is used on input A, an event will only have an effect if the TCD is in Dead-time A or On-time A.

**Figure 22-14. Input Mode 3 on Input A**



If Input mode 3 is used on input B, an event will only have an effect if the TCD is in Dead-time B or On-time B.

**Figure 22-15. Input Mode 3 on Input B**

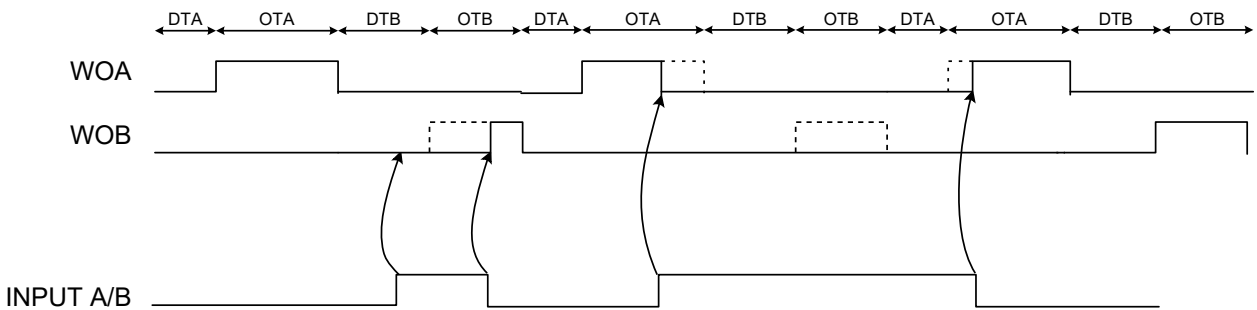


**Input Mode 4: Stop all Outputs, Maintain Frequency**

When Input mode 4 is used, both input A and input B will give the same functionality.

An input event will deactivate the outputs as long as the event is active. The TCD counter will not be affected by events in this Input mode.

**Figure 22-16. Input Mode 4**

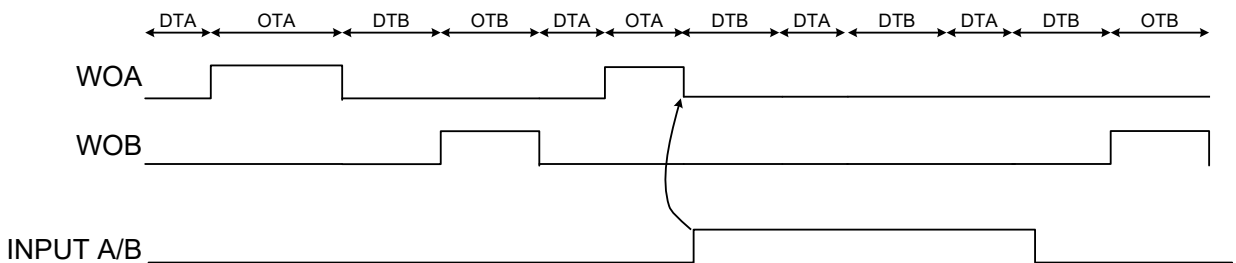


**Input Mode 5: Stop all Outputs, Execute Dead Time while Fault Active**

When Input mode 5 is used, both input A and input B give the same functionality:

The input event stops the outputs and starts on the opposite dead-time if it occurs during an on-time. If the event occurs during a dead-time, it will continue until the next on-time should start, but instead, it will jump to the next dead-time. As long as the input event is active, alternating dead-times will occur. When the input event stops, the ongoing dead-time will finish and the next on-time will continue in the normal flow.

**Figure 22-17. Input Mode 5**

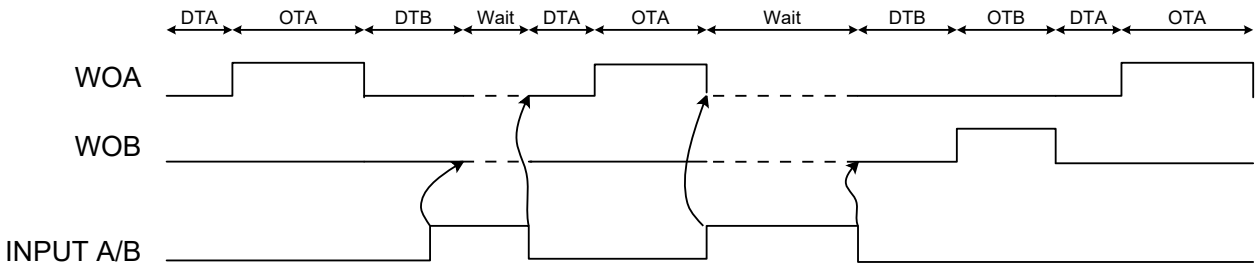


**Input Mode 6: Stop All Outputs, Jump to Next Compare Cycle, and Wait**

When Input mode 6 is used both input A and input B will give the same functionality. The input event stops the outputs and jumps to the opposite dead-time if it occurs during an on-time. If the event occurs during a dead-time, it will continue until the next on-time should start, but instead, it will jump to the next dead-time. As long as the input event is active, the TCD counter will wait. When the input events stops, the next dead-time will start and normal flow will continue.



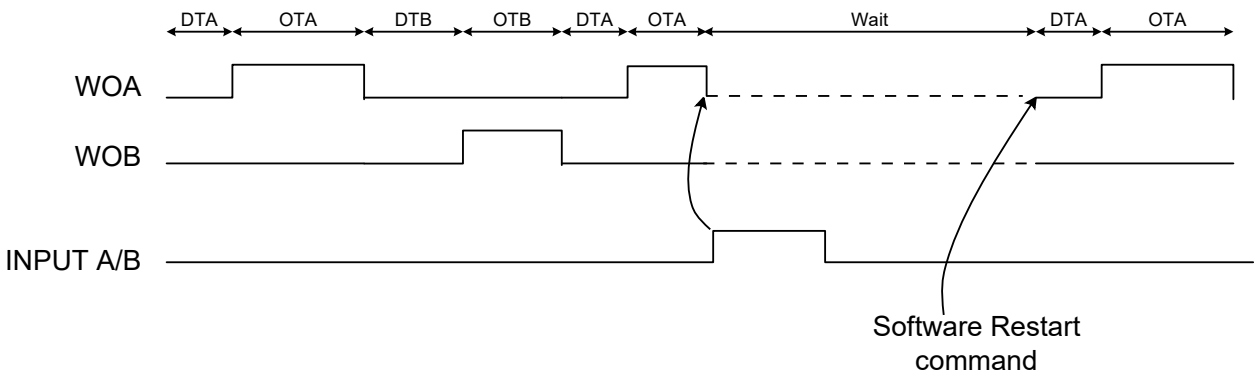
**Figure 22-18. Input Mode 6**



**Input Mode 7: Stop all Outputs, Wait for Software Action**

When Input mode 7 is used, both input A and input B will give the same functionality. The input events stop the outputs and the TCD counter. It will be stopped until a Restart command is given. If the input event is still high when the Restart command is given, it will just stop again. When the TCD counter restarts, it will always start on Dead-time A.

**Figure 22-19. Input Mode 7**

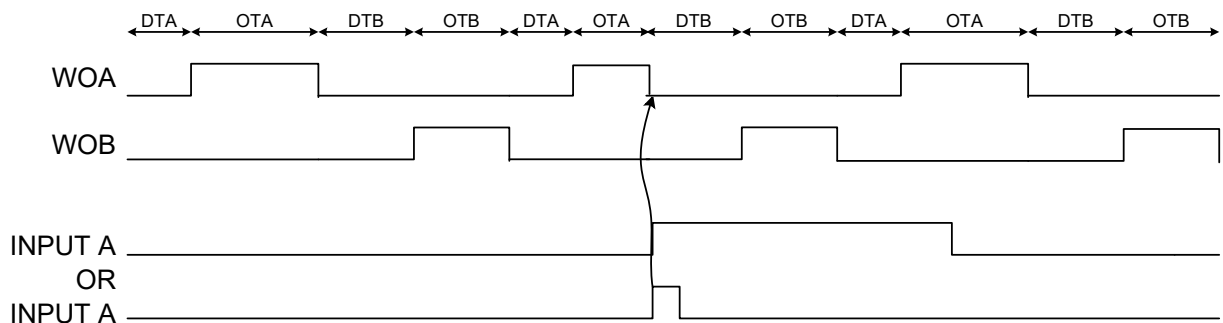


**Input Mode 8: Stop Output on Edge, Jump to Next Compare Cycle**

In Input mode 8, a positive edge on the input event while the corresponding output is ON will cause the output to stop and the TCD counter jump to the opposite dead-time.

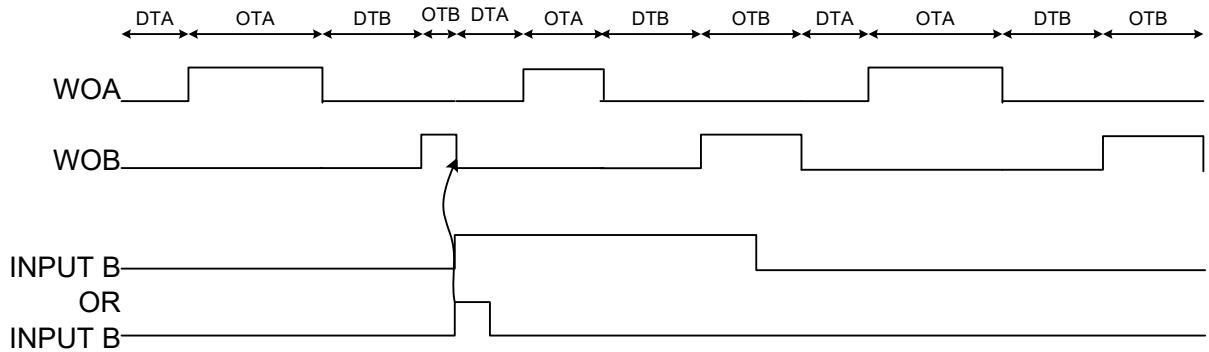
If Input mode 8 is used on input A and a positive input event occurs while in On-time A, the TCD counter jumps to Dead-time B.

**Figure 22-20. Input Mode 8 on Input A**



If Input mode 8 is used on input B and a positive input event occurs while in On-time B, the TCD counter jumps to Dead-time A.

**Figure 22-21. Input Mode 8 on Input B**

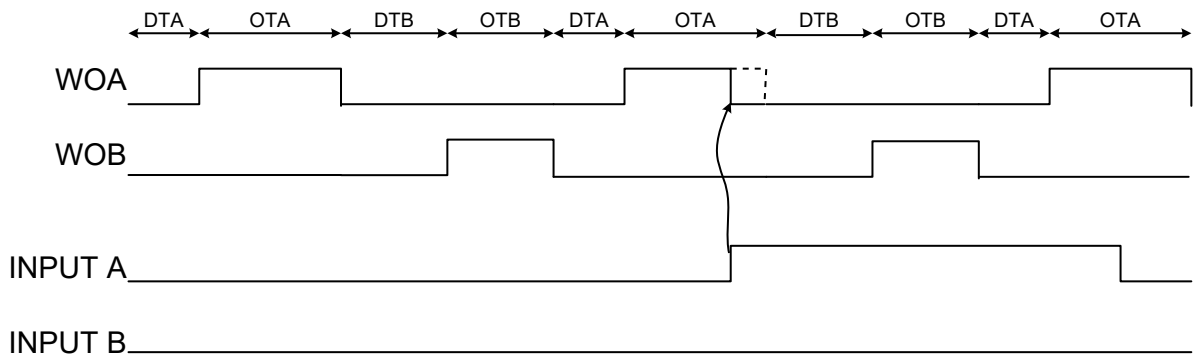


**Input Mode 9: Stop Output at Level, Maintain Frequency**

In Input mode 9 a positive edge on the input event while the corresponding output is ON will cause the output to stop during the rest of the on-time. The TCD counter will not be affected by the event, only the output.

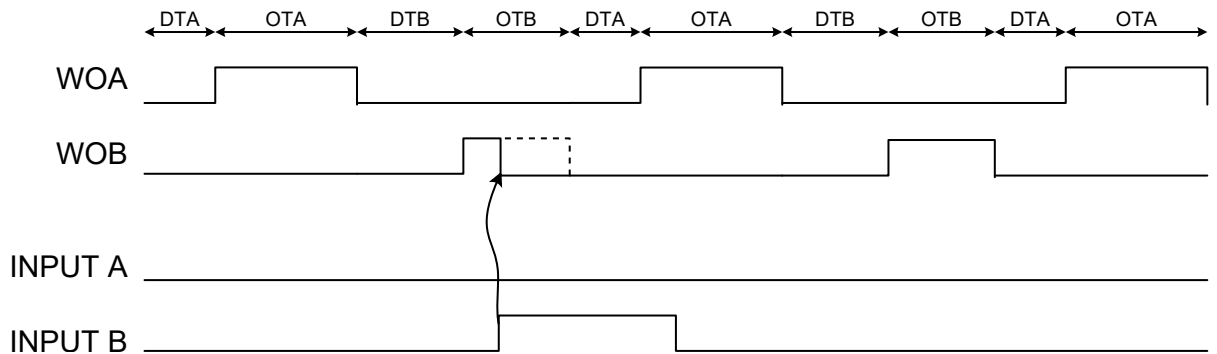
If Input mode 9 is used on input A and a positive input event occurs while in On-time A, the output will be OFF for the rest of the on-time.

**Figure 22-22. Input Mode 9 on Input A**



If Input mode 9 is used on input B and a positive input event occurs while in On-time B, the output will be OFF for the rest of the on-time.

**Figure 22-23. Input Mode 9 on Input B**

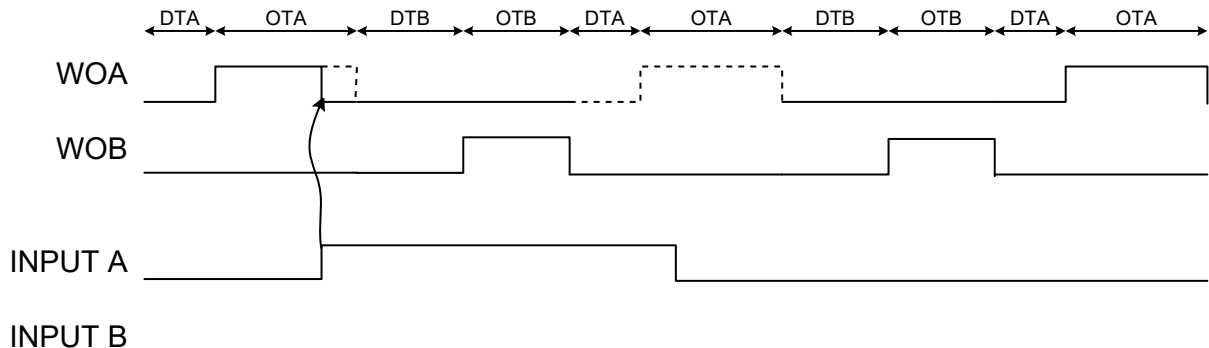


**Input Mode 10: Stop Output on Edge, Maintain Frequency**

In Input mode 10 the input event will cause the corresponding output to stop as long as the input is active. If the input goes low while there should have been an on-time on the corresponding output, the output will be deactivated for the rest of the on-time, too. The TCD counter is not affected by the event, only the output.

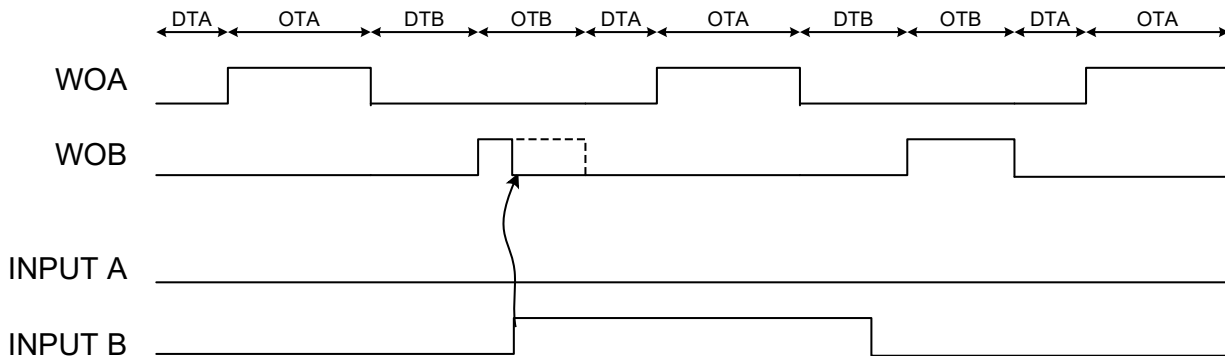
If Input mode 10 is used on input A and an input event occurs, the WOA will be OFF as long as the event lasts. If released during an on-time, it will be OFF for the rest of the on-time.

**Figure 22-24. Input Mode 10 on Input A**



If Input mode 10 is used on input B and an input event occurs, the WOB will be OFF as long as the event lasts. If released during an on-time, it will be OFF for the rest of the on-time.

**Figure 22-25. Input Mode 10 on Input B**



### Input Mode Summary

The table below summarizes the conditions as illustrated in the timing diagrams of the preceding sections.

**Table 22-6. Input Mode Summary**

INPUTMODE	Trigger → Output Affected	Fault On/Active	Fault Release/Inactive
0x00	-	No action	No action
0x01	Input A→WOA	End current on-time and wait	Start with dead-time for other compare
	Input B→WOB		
0x02	Input A→WOA	End current on-time.	Start with dead-time for current compare
	Input B→WOB	Execute other compare cycle and wait	
0x03	Input A→WOA	End current on-time.	Re-enable current compare cycle
	Input B→WOB	Execute other compare cycle	
0x04	Input A→{WOA, WOB}	Deactivate outputs	

INPUTMODE	Trigger → Output Affected	Fault On/Active	Fault Release/Inactive
	Input B→{WOA, WOB}		
0x05	Input A→{WOA, WOB}	Execute dead-time only	
	Input B→{WOA, WOB}		
0x06	Input A→{WOA, WOB}	End on-time and wait	Start with dead-time for other compare
	Input B→{WOA, WOB}		
0x07	Input A→{WOA, WOB}	End on-time and wait for software action	Start with dead-time for current compare
	Input B→{WOA, WOB}		
0x08	Input A→WOA	End current on-time and continue with other off-time	
	Input B→WOB		
0x09	Input A→WOA	Block current on-time and continue sequence	
	Input B→WOB		
0x0A	Input A→WOA	Deactivate on-time until end of sequence while trigger is active	
	Input B→WOB		
other	-	-	-

### 22.3.2.5 Dithering

If it is not possible to achieve the desired frequency because of prescaler/period selection limitations, dithering can be used to approximate the desired frequency and reduce waveform drift.

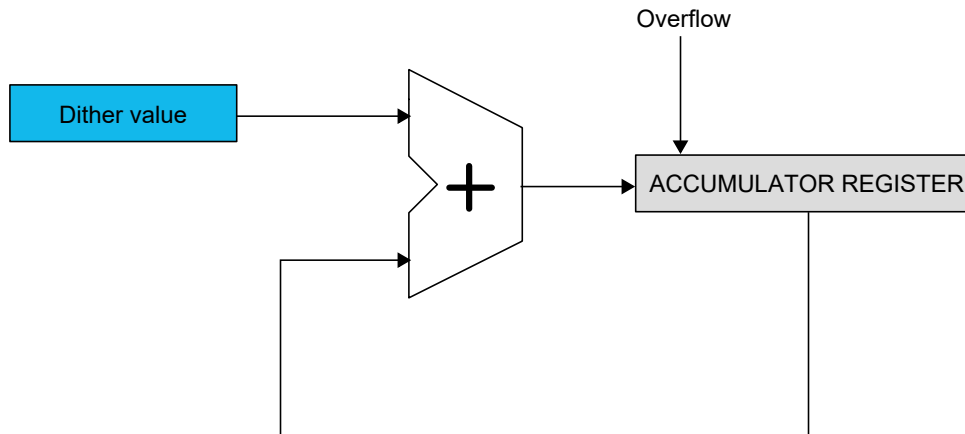
Dither accumulates the fractional error of the counter clock for each cycle. When the fractional error overflows, an additional cycle is added to the selected part of the cycle.

#### Example 22-1. Generate 75 kHz from 10 MHz Clock

If the timer clock frequency is 10 MHz, it will give the timer a resolution of 100 ns. The desired output frequency is 75 kHz, which means a period of 13333 ns. This period is not possible to achieve with a constant period with a 100 ns resolution, it would require 133.33 cycles. The output period can be set to either 133 cycles (75.188 kHz) or 134 cycles (74.626 kHz).

It is possible to change the period between the two frequencies manually in the firmware to get an average output frequency of 75 kHz (change every 3<sup>rd</sup> period to 134 cycles). The dither can do this automatically by accumulating the error (0.33 cycles). The accumulator calculates when the accumulated error is larger than one clock cycle and when that happens it adds an additional cycle to the timer period.

**Figure 22-26. Dither Logic**



The user can select where in the TCD cycle the Dither will be added by writing to the Dither Selection bits in the Dither Control register (DITHERSEL in TCDn.DITCTRL):

- On-time B
- On-time A and B
- Dead-time B
- Dead-time A and B

How much the Dithering will affect the TCD cycle time depends on what Waveform Generation mode is used, see the table below.

Dithering is not supported in Dual Slope mode.

**Table 22-7. Mode-Dependent Dithering Additions to TCD Cycle**

WAVEGEN	DITHERSEL in TCDn.DITCTRL	Additional TCD Clock Cycles to TCD Cycle
One Ramp mode	On-time B	1
	On-time A and B	1
	Dead-time B	0
	Dead-time A and B	0
Two Ramp mode	On-time B	1
	On-time A and B	2
	Dead-time B	0
	Dead-time A and B	0
Four Ramp mode	On-time B	1
	On-time A and B	2
	Dead-time B	1
	Dead-time A and B	2
Dual Slope mode	On-time B	0 (not supported)
	On-time A and B	0 (not supported)

WAVEGEN	DITHERSEL in TCDn.DITCTRL	Additional TCD Clock Cycles to TCD Cycle
	Dead-time B	0 (not supported)
	Dead-time A and B	0 (not supported)

The differences in the number of TCD clock cycles added to the TCD cycle is caused by the different number of compare values used by the TCD cycle. For example, in One Ramp mode, only CMPBCLR affects the TCD cycle time.

For DITHERSEL configurations where no extra cycles are added to the TCD cycles, compensation is reached by shortening the following output state.

### Example 22-2. DITHERSEL in One Ramp Mode

In One Ramp mode with DITHERSEL selecting Dead-time B, the Dead-time B will be increased by one cycle when dither overflow occurs. This reduces On-time B by one cycle.

### 22.3.2.6 TCD Counter Capture

Because the TCD counter is asynchronous to the system clock it is not possible to read out the counter value directly. It is possible to capture the TCD counter value, synchronized to the I/O clock domain in two different ways:

- Capture value on input events
- Software capture

The capture logic contains two separate capture blocks, CAPTUREA and CAPTUREB, that can capture and synchronize the TCD counter value to the I/O clock domain. CAPTUREA/B can be triggered by input event A/B or by software.

The capture values can be read by reading first TCDn.CAPTURExL and then TCDn.CAPTURExH registers.

### Captures Triggered by Input Events

To enable capture on input event, write a '1' to the ACTION bit in the respective Event Control x register (TCDn.EVCTRL) when configuring an event input.

When a capture has occurred, the TRIGA/B flag is raised in the Interrupt Flags register (TCDn.INTFLAGS). The according TRIGA/B interrupt is executed if enabled by writing a '1' to the respective Trigger Interrupt x Enable bit (TRIGx) in the Interrupt Control register (TCDn.INTCTRL). By polling TRIGx in TCDn.INTFLAGS, the user knows that a CAPTUREx value is available, and can read out the value by reading first the TCDn.CAPTURExL and then TCDn.CAPTURExH registers.

### Example 22-3. PWM Capture

In order to do PWM capture connect both event A and event B to the same asynchronous event channel that contains the PWM signal. To get information on the PWM signal, configure one event input to capture the rising edge of the signal. Configure the other event input to capture the falling edge of the signal.

### Capture Triggered by Software

The software can capture the TCD value by writing a '1' to respective Software Capture A/B Strobe bit (SCAPTUREx) in the Control E register (TCDn.CTRLE). When this command is executed and the Command Ready bit (CMDRDY) in the Status register (TCDn.STATUS) reads '1' again, the CAPTUREA/B value is available. It can now be read by reading first the TCDn.CAPTURExL and then the TCDn.CAPTURExH registers.

### Using Capture Together with Input Modes

The capture functionality can be used together with Input modes. The same event will then both capture the counter value and trigger a change in the counter flow, depending on the Input mode selected.

#### Example 22-4. Reset One Ramp Mode by Input Event Capture

In One Ramp mode, the counter can be reset by an input event capture. To achieve this, use input event B and write the TCDn.INPUTCTRLB register to 0x08.

### Related Links

[22.3.1 Initialization and Disabling](#)

#### 22.3.2.7 Output Control

The outputs are configured by writing to the Fault Control register (TCDn.FAULTCTRL). TCDn.FAULTCTRL is only reset to '0' after a POR reset. During the reset sequence after any Reset, TCDn.FAULTCTRL will get its values from the TCD Fuse (FUSE.TDCDFG).

The Compare x Enable bits (CMPxEN in TCDn.FAULTCTRL) enable the different outputs. The CMPx bits in TCDn.FAULTCTRL set the value the registers should have after Reset or when a fault is triggered.

The TCD itself generates two different outputs, WOA and WOB. The two additional outputs WOC and WOD can be configured by software to be connected to either WOA or WOB by writing the Compare C/D Output Select bits (CMPCSEL and CMPDSEL) in the Control C register (TCDn.CTRLC).

The user can also override the outputs based on the TCD counter state by writing a '1' to the Compare Output Value Override bit in the Control C register (CMPOVR in TCDn.CTRLC). The user can then select the output values in the different dead- and on-times by writing to the Compare x Value bit fields in the Control D register (CMPAVAL and CMPBVAL in TCDn.CTRLD).

When used in One Ramp mode, WOA will only use the setup for Dead-Time A (DTA) and On-Time A (OTA) to set the output. WOB will only use Dead-Time B (DTB) and On-Time B (OTB) values to set the output.

When using the override feature together with faults detection (input modes) the CMPA (and CMPC/D if WOC/D equals WOA) bit in TCDn.FAULTCTRL should be equal to CMPAVAL[0] and [2] in CTRLD if not the first cycle after a fault is detected can have the wrong polarity on the outputs. The same applies to CMPB in TCDn.FAULTCTRL (and CMPC/D if WOC/D equals WOB) bit, which should be equal to CMPBVAL[0] and [2] in TCDn.CTRLD.

Due to the asynchronous nature of the TCD, that input events immediately can affect the output signal, there is a risk of nano-second spikes occurring on the output when there is no load on the pin. The case occurs in any Input mode different from '0' and when an input event is triggering. The spike value will always be in direction of the CMPx value given by the TCDn.FAULTCTRL register.

### Related Links

[6.10.4.4 TCD0CFG](#)

### 22.3.3 Events

The TCD can generate the following output events:

- TCD counter matches CMPBCLR
- TCD counter matches CMPASET
- TCD counter matches CMPBSET
- Programmable TCD output event. The user can select the trigger and all the different compare matches. In addition, it is possible to delay the output event from 0 to 256 TCD delay cycles.

The three events based on the counter match directly generate event strobes that last one clock cycle on the TCD counter clock. The programmable output event generates an event strobe that last one clock cycle on the TCD synchronizer clock.

The TCD has the possibility to receive these input events:

- Input A
- Input B

#### Related Links

[22.3.2.4 TCD Inputs](#)

[14. EVSYS - Event System](#)

### 22.3.3.1 Programmable Output Events

Programmable output event uses the same logic as the input blanking for trigger selection and delay. It is therefore not possible to configure the functionalities independently. If the input blanking functionality is used, the output event cannot be delayed and the trigger used for input blanking will also be used for the output event.

The programmable output events are controlled by the TCDn.DLYCTRL and TCDn.DLYVAL registers. It is possible to delay the output event by 0 to 256 TCD delay clock cycles if the DLYTRIG bits in TCDn.DLYCTRL is set to 0x2. The delayed output event functionality uses the TCD delay clock and counts until the DLYVAL value is reached before the trigger is sent out as an event. The TCD delay clock is a prescaled version of the TCD synchronization clock and the division factor is set by the DLYPRESC bits in the TCDn.DLYCTRL register. The output event will be delayed by TCD clock period x DLYPRESC division factor x DLYVAL.

### 22.3.4 Interrupts

**Table 22-8. Available Interrupt Vectors and Sources**

Offset	Name	Vector Description	Conditions
0x00	OVF	Overflow interrupt	The TCD is done with one TCD cycle.
0x02	TRIG	Trigger interrupt	<ul style="list-style-type: none"> <li>• TRIGA: Counter is entering On-Time A</li> <li>• TRIGB: Counter is entering On-Time B</li> </ul>

When an interrupt condition occurs, the corresponding interrupt flag is set in the Interrupt Flags register of the peripheral (*peripheral*.INTFLAGS).

An interrupt source is enabled or disabled by writing to the corresponding enable bit in the peripheral's Interrupt Control register (*peripheral*.INTCTRL).



An interrupt request is generated when the corresponding interrupt source is enabled and the interrupt flag is set. The interrupt request remains active until the interrupt flag is cleared. See the peripheral's INTFLAGS register for details on how to clear interrupt flags.

When several interrupt request conditions are supported by an interrupt vector, the interrupt requests are ORed together into one combined interrupt request to the interrupt controller. The user must read the peripheral's INTFLAGS register to determine which of the interrupt conditions are present.

**Related Links**

[13. CPUINT - CPU Interrupt Controller](#)

[8.7.3 SREG](#)

**22.3.5 Sleep Mode Operation**

The TCD operates in Idle Sleep mode and is stopped when entering Standby and Power-Down Sleep modes.

**22.3.6 Synchronization**

The TCD has two different clock domains and needs to synchronize the communication between the domains. See the Initialization section for details on how the synchronization of values from the I/O clock domain to the TCD clock domain is done. See the Capture section for details on how the synchronization of values from the TCD clock domain to the I/O clock domain is done.

**Related Links**

[22.3.1 Initialization and Disabling](#)

[22.3.2.6 TCD Counter Capture](#)

**22.3.7 Configuration Change Protection**

This peripheral has registers that are under Configuration Change Protection (CCP). In order to write to these, a certain key must be written to the CPU.CCP register first, followed by a write access to the protected bits within four CPU instructions.

Attempting to write to a protected register without following the appropriate CCP unlock sequence leaves the protected register unchanged.

The following registers are under CCP:

**Table 22-9. TCD - Registers under Configuration Change Protection**

Register	Key
FAULTCTRL	IOREG

### 22.4 Register Summary - TCD

Offset	Name	Bit Pos.								
0x00	<a href="#">CTRLA</a>	7:0		CLKSEL[1:0]		CNTPRES[1:0]		SYNCPRES[1:0]		ENABLE
0x01	<a href="#">CTRLB</a>	7:0							WGMODE[1:0]	
0x02	<a href="#">CTRLC</a>	7:0	CMPDSEL	CMPCSEL		FIFTY		AUPDATE		CMPOVR
0x03	<a href="#">CTRLD</a>	7:0	CMPBVAL[3:0]			CMPAVAL[3:0]				
0x04	<a href="#">CTRLF</a>	7:0	DISEOC			SCAPTUREB	SCAPTUREA	RESTART	SYNC	SYNCEOC
0x05	...									
0x07	Reserved									
0x08	<a href="#">EVCTRLA</a>	7:0	CFG[1:0]			EDGE		ACTION		TRIGEI
0x09	<a href="#">EVCTRLB</a>	7:0	CFG[1:0]			EDGE		ACTION		TRIGEI
0x0A	...									
0x0B	Reserved									
0x0C	<a href="#">INTCTRL</a>	7:0					TRIGB	TRIGA		OVF
0x0D	<a href="#">INTFLAGS</a>	7:0					TRIGB	TRIGA		OVF
0x0E	<a href="#">STATUS</a>	7:0	PWMACTB	PWMACTA					CMDRDY	ENRDY
0x0F	Reserved									
0x10	<a href="#">INPUTCTRLA</a>	7:0					INPUTMODE[3:0]			
0x11	<a href="#">INPUTCTRLB</a>	7:0					INPUTMODE[3:0]			
0x12	<a href="#">FAULTCTRL</a>	7:0	CMPDEN	CMPCEN	CMPBEN	CMPAEN	CMPD	CMPC	CMPB	CMPA
0x13	Reserved									
0x14	<a href="#">DLYCTRL</a>	7:0			DLYPRESC[1:0]		DLYTRIG[1:0]		DLYSEL[1:0]	
0x15	<a href="#">DLYVAL</a>	7:0	DLYVAL[7:0]							
0x16	...									
0x17	Reserved									
0x18	<a href="#">DITCTRL</a>	7:0							DITHERSEL[1:0]	
0x19	<a href="#">DITVAL</a>	7:0					DITHER[3:0]			
0x1A	...									
0x1D	Reserved									
0x1E	<a href="#">DBGCTRL</a>	7:0						FAULTDET		DBGRUN
0x1F	...									
0x21	Reserved									
0x22	<a href="#">CAPTUREA</a>	7:0	CAPTURE[7:0]							
		15:8	CAPTURE[11:8]							
0x24	<a href="#">CAPTUREB</a>	7:0	CAPTURE[7:0]							
		15:8	CAPTURE[11:8]							
0x26	...									
0x27	Reserved									
0x28	<a href="#">CMPASET</a>	7:0	CMPSET[7:0]							
		15:8	CMPSET[11:8]							

Offset	Name	Bit Pos.								
0x2A	CMPACLR	7:0	CMPCLR[7:0]							
		15:8								CMPCLR[11:8]
0x2C	CMPBSET	7:0	CMPSET[7:0]							
		15:8								CMPSET[11:8]
0x2E	CMPBCLR	7:0	CMPCLR[7:0]							
		15:8								CMPCLR[11:8]

### 22.5 Register Description

### 22.5.1 Control A

**Name:** CTRLA  
**Offset:** 0x00  
**Reset:** 0x00  
**Property:** Enable-protected

Bit	7	6	5	4	3	2	1	0
		CLKSEL[1:0]		CNTPRES[1:0]		SYNCPRES[1:0]		ENABLE
Access		R/W	R/W	R/W	R/W	R/W	R/W	R/W
Reset		0	0	0	0	0	0	0

#### Bits 6:5 – CLKSEL[1:0] Clock Select

The clock select bits select the clock source of the TCD clock.

Value	Description
0x0	OSC20M
0x1	Reserved
0x2	External clock
0x3	System clock

#### Bits 4:3 – CNTPRES[1:0] Counter Prescaler

The Counter Prescaler bits select the division factor of the TCD counter clock.

Value	Description
0x0	Division factor 1
0x1	Division factor 4
0x2	Division factor 32
0x3	Reserved

#### Bits 2:1 – SYNCPRES[1:0] Synchronization Prescaler

The synchronization prescaler bits select the division factor of the TCD clock.

Value	Description
0x0	Division factor 1
0x1	Division factor 2
0x2	Division factor 4
0x3	Division factor 8

#### Bit 0 – ENABLE Enable

When this bit is written to, it will automatically be synchronized to the TCD clock domain.

This bit can be changed as long as synchronization of this bit is not ongoing, see Enable Ready bit (ENRDY) in Status register (TCDn.STATUS).

This bit is not enable-protected.

Value	Description
0	The TCD is disabled.
1	The TCD is enabled and running.

### 22.5.2 Control B

**Name:** CTRLB  
**Offset:** 0x01  
**Reset:** 0x00  
**Property:** -

Bit	7	6	5	4	3	2	1	0
							WGMODE[1:0]	
Access							R/W	R/W
Reset							0	0

#### Bits 1:0 – WGMODE[1:0] Waveform Generation Mode

These bits select the waveform generation.

Value	Name	Description
0x0	ONERAMP	One Ramp mode
0x1	TWORAMP	Two Ramp mode
0x2	FOURRAMP	Four Ramp mode
0x3	DS	Dual-Slope mode

### 22.5.3 Control C

**Name:** CTRLC  
**Offset:** 0x02  
**Reset:** 0x00  
**Property:** -

Bit	7	6	5	4	3	2	1	0
	CMPDSEL	CMPCSEL			FIFTY		AUPDATE	CMPOVR
Access	R/W	R/W			R/W		R/W	R/W
Reset	0	0			0		0	0

#### Bit 7 – CMPDSEL Compare D Output Select

Value	Name	Description
0	PWMA	Waveform A
1	PWMB	Waveform B

#### Bit 6 – CMPCSEL Compare C Output Select

Value	Name	Description
0	PWMA	Waveform A
1	PWMB	Waveform B

#### Bit 3 – FIFTY Fifty Percent Waveform

If the two waveforms have identical characteristics, this bit can be written to '1'. This will cause any values written to register TCDn.CMPBSET/TCDn.CLR also to be written to the register TCDn.CMPASET/TCDn.CLR.

#### Bit 1 – AUPDATE Automatically Update

If this bit is written to '1' a synchronization at the end of the TCD cycle is automatically requested after the Compare B Clear High register (TCDn.CMPBCLR) is written.

If the fifty percent waveform is enabled by setting the FIFTY bit in this register, writing the Compare A Clear High register will also request a synchronization at the end of the TCD cycle if the AUPDATE bit is set.

#### Bit 0 – CMPOVR Compare Output Value Override

When this bit is written to '1', default values of the Waveform Outputs A and B are overridden by the values written in the Compare x Value in active state bit fields in the Control D register (CMPnxVAL bit in TCDn.CTRLD). See the Control D register description for more details.

### 22.5.4 Control D

**Name:** CTRLD  
**Offset:** 0x03  
**Reset:** 0x00  
**Property:** -

Bit	7	6	5	4	3	2	1	0
	CMPBVAL[3:0]				CMPAVAL[3:0]			
Access	R/W	R/W	R/W	R/W	R/W	R/W	R/W	R/W
Reset	0	0	0	0	0	0	0	0

**Bits 0:3, 4:7 – CMPVAL** Compare x Value (in active state)

These bits set the active state for the different ramps for compare x.

These settings are only valid if the Compare Output Value Override bit in the Control C register (CMPOVR bit in TCDn.CTRLA) is written to '1'.

CMPxVAL	A_off	A_on	B_off	B_on
PWMA	CMPAVAL[0]	CMPAVAL[1]	CMPAVAL[2]	CMPAVAL[3]
PWMB	CMPBVAL[0]	CMPBVAL[1]	CMPBVAL[2]	CMPBVAL[3]

In One Ramp mode, PWMA will only use A\_off and A\_on values and PWMB will only use B\_off and B\_on values. This is due to possible overlap between the values A\_off, A\_on, B\_off, and B\_on.

### 22.5.5 Control E

**Name:** CTRL E  
**Offset:** 0x04  
**Reset:** 0x00  
**Property:** -

Bit	7	6	5	4	3	2	1	0
	DISEOC			SCAPTUREB	SCAPTUREA	RESTART	SYNC	SYNCEOC
Access	R/W			R/W	R/W	R/W	R/W	R/W
Reset	0			0	0	0	0	0

**Bit 7 – DISEOC** Disable at End of TCD Cycle Strobe

When this bit is written, the TCD will automatically disable at the end of the TCD cycle.

When this bit is written to ‘1’, the ENRDY in TCDn.STATUS will stay low until the TCD is disabled.

Writing to this bit has only effect if there is no ongoing synchronization of Enable. See also the ENRDY bit in TCDn.STATUS.

**Bit 4 – SCAPTUREB** Software Capture B Strobe

When this bit is written to ‘1’, a software capture to Capture register B (TCDn.CAPTUREBL/H) is done as soon as the strobe is synchronized to the TCD domain.

Writing to this bit has only effect if there is no ongoing synchronization of a command. See also the CMDRDY bit in TCDn.STATUS.

**Bit 3 – SCAPTUREA** Software Capture A Strobe

When this bit is written to ‘1’, a software capture to Capture register A (TCDn.CAPTUREAL/H) is done as soon as the strobe is synchronized to the TCD domain.

Writing to this bit has only effect if there is no ongoing synchronization of a command. See also the CMDRDY bit in TCDn.STATUS.

**Bit 2 – RESTART** Restart Strobe

When this bit is written a restart of the TCD counter is executed as soon as this bit is synchronized to the TCD domain.

Writing to this bit has only effect if there is no ongoing synchronization of a command. See also the CMDRDY bit in TCDn.STATUS.

**Bit 1 – SYNC** Synchronize Strobe

When this bit is written to ‘1’ the double-buffered registers will be loaded to the TCD domain as soon as this bit is synchronized to the TCD domain.

Writing to this bit has only effect if there is no ongoing synchronization of a command. See also the CMDRDY bit in TCDn.STATUS.

**Bit 0 – SYNCEOC** Synchronize End of TCD Cycle Strobe

When this bit is written to ‘1’ the double-buffered registers will be loaded to the TCD domain at the end of the next TCD cycle.



Writing to this bit has only effect if there is no ongoing synchronization of a command. See also the CMDRDY bit in TCDn.STATUS.

### 22.5.6 Event Control x

**Name:** EVCTRL  
**Offset:** 0x08 + n\*0x01 [n=0..1]  
**Reset:** 0x00  
**Property:** -

Bit	7	6	5	4	3	2	1	0
	CFG[1:0]			EDGE		ACTION		TRIGE1
Access	R/W	R/W		R/W		R/W		R/W
Reset	0	0		0		0		0

#### Bits 7:6 – CFG[1:0] Event Configuration

When the input capture noise canceler is activated (FILTERON), the event input is filtered. The filter function requires four successive equal valued samples of the retrigger pin for changing its output. The input capture is therefore delayed by four clock cycles when the noise canceler is enabled.

When the Asynchronous Event is enabled (ASYNCON), the event input will qualify the output directly.

Value	Name	Description
0x0	NEITHER	Neither filter nor asynchronous event is enabled.
0x1	FILTERON	Input capture noise cancellation filter enabled.
0x2	ASYNCON	Asynchronous event output qualification enabled.
other	-	Reserved.

#### Bit 4 – EDGE Edge Selection

This bit is used to select the active edge or level for the event input.

Value	Name	Description
0	FALL_LOW	The falling edge or low level of the event input generates retrigger or fault action.
1	RISE_HIGH	The rising edge or high level of the event input generates retrigger or fault action.

#### Bit 2 – ACTION Event Action

This bit enables capture on event input. By default, the input will trigger a fault, depending on the Input x register Input mode (INPUTx). It is also possible to trigger a capture on the event input.

Value	Name	Description
0	FAULT	Event triggers a fault.
1	CAPTURE	Event triggers a fault and capture.

#### Bit 0 – TRIGE1 Trigger Event Input Enable

Writing this bit to '1' enables event as trigger for input A.

### 22.5.7 Interrupt Control

**Name:** INTCTRL  
**Offset:** 0x0C  
**Reset:** 0x00  
**Property:** -

Bit	7	6	5	4	3	2	1	0
					TRIGB	TRIGA		OVF
Access					R/W	R/W		R/W
Reset					0	0		0

**Bits 2, 3 – TRIG** Trigger x Interrupt Enable

Writing this bit to '1' enables executing an interrupt when trigger input x is received.

**Bit 0 – OVF** Counter Overflow

Writing this bit to '1' enables executing an interrupt at restart of the sequence or overflow of the counter.

### 22.5.8 Interrupt Flags

**Name:** INTFLAGS  
**Offset:** 0x0D  
**Reset:** 0x00  
**Property:** -

Bit	7	6	5	4	3	2	1	0
					TRIGB	TRIGA		OVF
Access					R/W	R/W		R/W
Reset					0	0		0

**Bits 2, 3 – TRIG** Trigger x Interrupt Flag

When a capture has occurred, the TRIGA/B is raised. This bit is cleared by writing a '1' to it.

**Bit 0 – OVF** Overflow Interrupt Flag

When a capture is overflow, this flag is raised. This bit is cleared by writing a '1' to it.

### 22.5.9 Status

**Name:** STATUS  
**Offset:** 0x0E  
**Reset:** 0x00  
**Property:** -

Bit	7	6	5	4	3	2	1	0
	PWMACTB	PWMACTA					CMDRDY	ENRDY
Access	R/W	R/W					R	R
Reset	0	0					0	0

#### Bits 6, 7 – PWMACT PWM Activity on x

This bit is set by hardware each time the output WO toggles from 0 to 1 or from 1 to 0.

This status bit must be cleared by software by writing a '1' to it before new PWM activity can be detected.

#### Bit 1 – CMDRDY Command Ready

This status bit tells when a command is synced to the TCD domain and the system is ready to receive new commands.

The following clears the CMDRDY bit:

1. TCDn.CTRLA SYNCEOC strobe.
2. TCDn.CTRLA SYNC strobe.
3. TCDn.CTRLA RESTART strobe.
4. TCDn.CTRLA SCAPTUREA Capture A strobe.
5. TCDn.CTRLA SCAPTUREB Capture B strobe.
6. TCDn.CTRLA AUPDATE written to '1' and writing to TCDn.CMPBCLR register.

#### Bit 0 – ENRDY Enable Ready

This status bit tells when the ENABLE value in TCDn.CTRLA is synced to the TCD domain and is ready to be written to again.

The following clears the ENRDY bit:

1. Writing to the ENABLE bit in TCDn.CTRLA.
2. TCDn.CTRLA DISEOC strobe.
3. Going into BREAK in an On-Chip Debugging (OCD) session while the Debug Run bit (DBGCTRL) in TCDn.DBGCTRL is not '1'.

### 22.5.10 Input Control x

**Name:** INPUTCTRL  
**Offset:** 0x10 + n\*0x01 [n=0..1]  
**Reset:** 0x00  
**Property:** -

Bit	7	6	5	4	3	2	1	0
					INPUTMODE[3:0]			
Access					R/W	R/W	R/W	R/W
Reset					0	0	0	0

#### Bits 3:0 – INPUTMODE[3:0] Input Mode

Value	Name	Description
0x0	NONE	Input has no action
0x1	JMPWAIT	Stop output, jump to opposite compare cycle, and wait
0x2	EXECWAIT	Stop output, execute opposite compare cycle, and wait
0x3	EXECFAULT	Stop output, execute opposite compare cycle while fault active
0x4	FREQ	Stop all outputs, maintain frequency
0x5	EXECDT	Stop all outputs, execute dead time while fault active
0x6	WAIT	Stop all outputs, jump to next compare cycle, and wait
0x7	WAITSW	Stop all outputs, wait for software action
0x8	EDGETRIG	Stop output on edge, jump to next compare cycle
0x9	EDGETRIGFREQ	Stop output on edge, maintain frequency
0xA	LVLTRIGFREQ	Stop output at level, maintain frequency

### 22.5.11 Fault Control

**Name:** FAULTCTRL  
**Offset:** 0x12  
**Reset:** Loaded from fuse  
**Property:** Configuration Change Protection

Bit	7	6	5	4	3	2	1	0
	CMPDEN	CMPDEN	CMPDEN	CMPDEN	CMPD	CMPC	CMPB	CMPA
Access	R/W	R/W	R/W	R/W	R/W	R/W	R/W	R/W
Reset	x	x	x	x	x	x	x	x

#### Bits 4, 5, 6, 7 – CMPEN Compare x Enable

These bits enable compare as output on the pin. At Reset, the content is kept and during the reset sequence loaded from the TCD Configuration Fuse (FUSE.TCDFG).

#### Bits 0, 1, 2, 3 – CMP Compare Value x

These bits set the default state from Reset, or when an input event triggers a fault causing changes to the output. At Reset, the content is kept and during the reset sequence loaded from the TCD Configuration Fuse (FUSE.TCDFG).

### 22.5.12 Delay Control

**Name:** DLYCTRL  
**Offset:** 0x14  
**Reset:** 0x00  
**Property:** -

Bit	7	6	5	4	3	2	1	0
			DLYPRESC[1:0]		DLYTRIG[1:0]		DLYSEL[1:0]	
Access			R/W	R/W	R/W	R/W	R/W	R/W
Reset			0	0	0	0	0	0

#### Bits 5:4 – DLYPRESC[1:0] Delay Prescaler

These bits control the prescaler settings for the blanking or output event delay.

Value	Description
0x0	Prescaler division factor 1
0x1	Prescaler division factor 2
0x2	Prescaler division factor 4
0x3	Prescaler division factor 8

#### Bits 3:2 – DLYTRIG[1:0] Delay Trigger

These bits control what should trigger the blanking or output event delay.

Value	Name	Description
0x0	CMPASET	CMPASET triggers delay
0x1	CMPACLR	CMPACLR triggers delay
0x2	CMPBSET	CMPBSET triggers delay
0x3	CMPBCLR	CMPASET triggers delay (end of cycle)

#### Bits 1:0 – DLYSEL[1:0] Delay Select

These bits control what function should be used by the delay trigger the blanking or output event delay.

Value	Description
0x0	Delay functionality not used
0x1	Input blanking enabled
0x2	Event delay enabled
0x3	Reserved



### 22.5.13 Delay Value

**Name:** DLYVAL  
**Offset:** 0x15  
**Reset:** 0x00  
**Property:** -

Bit	7	6	5	4	3	2	1	0
	DLYVAL[7:0]							
Access	R/W	R/W	R/W	R/W	R/W	R/W	R/W	R/W
Reset	0	0	0	0	0	0	0	0

#### Bits 7:0 – DLYVAL[7:0] Delay Value

These bits configure the blanking/output event delay time or event output synchronization delay in number of prescaled TCD cycles.

### 22.5.14 Dither Control

**Name:** DITCTRL  
**Offset:** 0x18  
**Reset:** 0x00  
**Property:** -

Bit	7	6	5	4	3	2	1	0
							DITHERSEL[1:0]	
Access							R/W	R/W
Reset							0	0

#### Bits 1:0 – DITHERSEL[1:0] Dither Select

These bits select which Compare register is using the Dither function. See [22.3.2.5 Dithering](#).

Value	Name	Description
0x0	ONTIMEB	On-time ramp B
0x1	ONTIMEAB	On-time ramp A and B
0x2	DEADTIMEB	Dead-time ramp B
0x3	DEADTIMEAB	Dead-time ramp A and B

### 22.5.15 Dither Value

**Name:** DITVAL  
**Offset:** 0x19  
**Reset:** 0x00  
**Property:** -

Bit	7	6	5	4	3	2	1	0
					DITHER[3:0]			
Access					R/W	R/W	R/W	R/W
Reset					0	0	0	0

#### Bits 3:0 – DITHER[3:0] Dither Value

These bits configure the fractional adjustment of the on-time or off-time according to Dither Selection bits (DITHERSEL) in the Dither Control register (TCDn.DITCTRL). The DITHER value is added to a 4-bit accumulator at the end of each TCD cycle. When the accumulator overflows the frequency adjustment will occur.

The DITHER bits are double-buffered so the new value is copied in at an update condition.

### 22.5.16 Debug Control

**Name:** DBGCTRL  
**Offset:** 0x1E  
**Reset:** 0x00  
**Property:** -

Bit	7	6	5	4	3	2	1	0
						FAULTDET		DBGRUN
Access						R/W		R/W
Reset						0		0

#### Bit 2 – FAULTDET Fault Detection

This bit defines how the peripheral behaves when stopped in Debug mode.

Value	Name	Description
0	NONE	No fault is generated if TCD is stopped in Debug mode.
1	FAULT	A fault is generated and both trigger flags are set if TCD is halted in Debug mode.

#### Bit 0 – DBGRUN Debug Run

When written to '1', the peripheral will continue operating in Debug mode when the CPU is halted.

Value	Description
0	The peripheral is halted in Break Debug mode and ignores events
1	The peripheral will continue to run in Break Debug mode when the CPU is halted

### 22.5.17 Capture x

**Name:** CAPTURE  
**Offset:** 0x22 + n\*0x02 [n=0..1]  
**Reset:** 0x00  
**Property:** -

For capture operation, these registers constitute the second buffer level and access point for the CPU. The TCDn.CAPTUREx registers are updated with the buffer value when an UPDATE condition occurs. CAPTURE A register contains the value from the TCD counter when a Trigger A or a software capture A occurs. CAPTURE B register contains the value from the TCD counter when Trigger B or software capture B occurs.

The TCD counter value is synchronized to CAPTUREx by either software or an event.

The capture register is blocked for an update of new capture data until TCDn.CAPTURExH is read.

Bit	15	14	13	12	11	10	9	8
	CAPTURE[11:8]							
Access					R	R	R	R
Reset					0	0	0	0
Bit	7	6	5	4	3	2	1	0
	CAPTURE[7:0]							
Access	R	R	R	R	R	R	R	R
Reset	0	0	0	0	0	0	0	0

**Bits 11:0 – CAPTURE[11:0] Capture Byte**

### 22.5.18 Compare Set x

**Name:** CMPSET  
**Offset:** 0x28 + n\*0x04 [n=0..1]  
**Reset:** 0x00  
**Property:** -

For compare operation, these registers are continuously compared to the counter value. Normally, the outputs from the comparators are then used for generating waveforms.

Bit	15	14	13	12	11	10	9	8
	CMPSET[11:8]							
Access					R/W	R/W	R/W	R/W
Reset					0	0	0	0
Bit	7	6	5	4	3	2	1	0
	CMPSET[7:0]							
Access	R/W	R/W	R/W	R/W	R/W	R/W	R/W	R/W
Reset	0	0	0	0	0	0	0	0

**Bits 11:0 – CMPSET[11:0]** Compare Set  
 These bits hold value of the compare register.

### 22.5.19 Compare Clear x

**Name:** CMPCLR  
**Offset:** 0x2A + n\*0x04 [n=0..1]  
**Reset:** 0x00  
**Property:** -

For compare operation, these registers are continuously compared to the counter value. Normally, the outputs from the comparators are then used for generating waveforms.

Bit	15	14	13	12	11	10	9	8
					CMPCLR[11:8]			
Access					R/W	R/W	R/W	R/W
Reset					0	0	0	0
Bit	7	6	5	4	3	2	1	0
	CMPCLR[7:0]							
Access	R/W	R/W	R/W	R/W	R/W	R/W	R/W	R/W
Reset	0	0	0	0	0	0	0	0

#### Bits 11:0 – CMPCLR[11:0] Compare x Clear

These bits hold the value of the compare register.

## 23. RTC - Real-Time Counter

### 23.1 Features

- 16-Bit Resolution
- Selectable Clock Source:
  - 32.768 kHz external crystal (XOSC32K)
  - External clock
  - 32 KHz internal ULP oscillator (OSCULP32K)
  - OSCULP32K divided by 32
- Programmable 15-Bit Clock Prescaling
- One Compare Register
- One Period Register
- Clear Timer On Period Overflow
- Optional Interrupt/Event on Overflow and Compare Match
- Periodic Interrupt and Event

### 23.2 Overview

The RTC peripheral offers two timing functions: the Real-Time Counter (RTC) and a Periodic Interrupt Timer (PIT).

The PIT functionality can be enabled independently of the RTC functionality.

#### **RTC - Real-Time Counter**

The RTC counts (prescaled) clock cycles in a Counter register, and compares the content of the Counter register to a Period register and a Compare register.

The RTC can generate both interrupts and events on compare match or overflow. It will generate a compare interrupt and/or event at the first count after the counter equals the Compare register value, and an overflow interrupt and/or event at the first count after the counter value equals the Period register value. The overflow will also reset the counter value to zero.

The RTC peripheral typically runs continuously, including in Low-Power Sleep modes, to keep track of time. It can wake-up the device from Sleep modes and/or interrupt the device at regular intervals.

The reference clock is typically the 32.768 kHz output from an external crystal. The RTC can also be clocked from an external clock signal, the 32 KHz internal Ultra Low-Power Oscillator (OSCULP32K), or the OSCULP32K divided by 32.

The RTC peripheral includes a 15-bit programmable prescaler that can scale down the reference clock before it reaches the counter. A wide range of resolutions and time-out periods can be configured for the RTC. With a 32.768 kHz clock source, the maximum resolution is 30.5  $\mu$ s, and time-out periods can be up to two seconds. With a resolution of 1s, the maximum time-out period is more than 18 hours (65536 seconds). The RTC can give a compare interrupt and/or event when the counter equals the compare register value, and an overflow interrupt and/or event when it equals the period register value.



### PIT - Periodic Interrupt Timer

Using the same clock source as the RTC function, the PIT can request an interrupt or trigger an output event on every  $n$ th clock period.  $n$  can be selected from {4, 8, 16,.. 32768} for interrupts, and from {64, 128, 256,.. 8192} for events.

The PIT uses the same clock source (CLK\_RTC) as the RTC function.

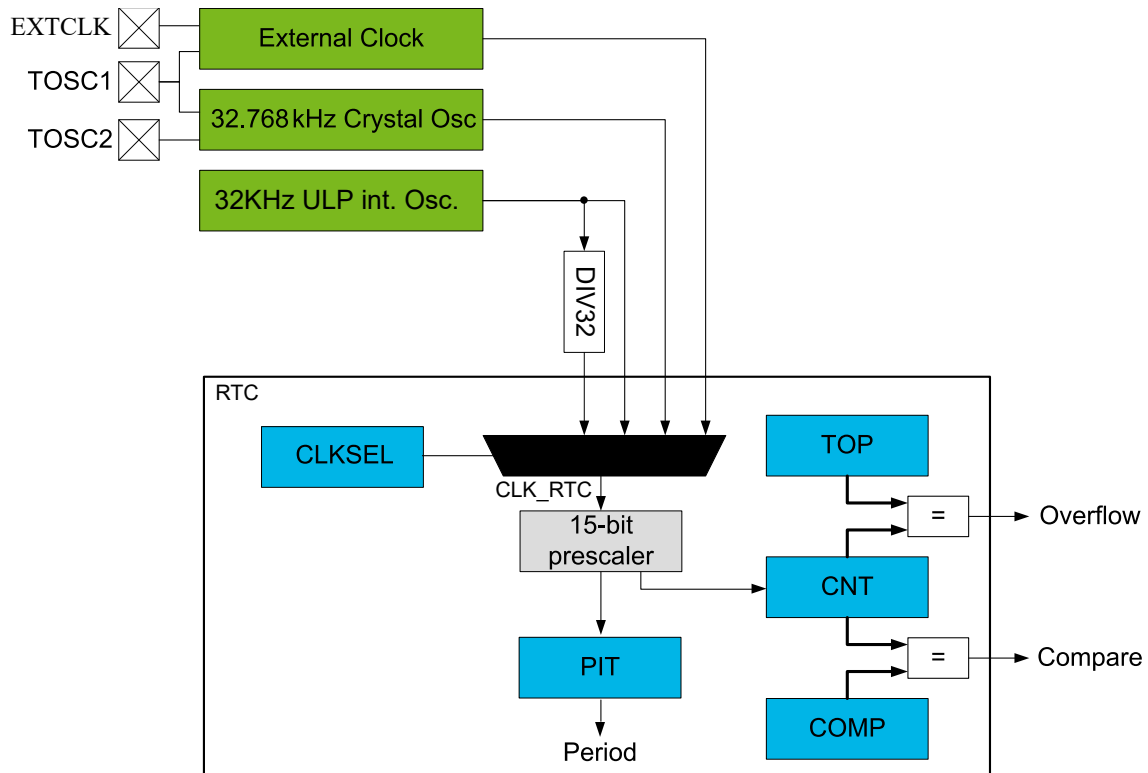
#### Related Links

[23.3 RTC Functional Description](#)

[23.4 PIT Functional Description](#)

### 23.2.1 Block Diagram

**Figure 23-1. Block Diagram**



### 23.2.2 Signal Description

Not applicable.

### 23.2.3 System Dependencies

In order to use this peripheral, other parts of the system must be configured correctly, as described below.

**Table 23-1. RTC System Dependencies**

Dependency	Applicable	Peripheral
Clocks	Yes	CLKCTRL
I/O Lines and Connections	Yes	PORT
Interrupts	Yes	CPUINT

Dependency	Applicable	Peripheral
Events	Yes	EVSYS
Debug	Yes	UPDI

### Related Links

- [23.2.3.1 Clocks](#)
- [23.2.3.2 I/O Lines and Connections](#)
- [23.2.3.5 Debug Operation](#)
- [23.2.3.3 Interrupts](#)
- [23.2.3.4 Events](#)

#### 23.2.3.1 Clocks

System clock (CLK\_PER) is required to be at least four times faster than the RTC clock (CLK\_RTC) for reading counter value, and this is regardless of the RTC\_PRESC setting.

### Related Links

- [10. CLKCTRL - Clock Controller](#)

#### 23.2.3.2 I/O Lines and Connections

A 32.768 kHz crystal can be connected to the TOSC1 or TOSC2 pins, along with any required load capacitors.

An external clock can be used on the TOSC1 pin.

### Related Links

- [10. CLKCTRL - Clock Controller](#)

#### 23.2.3.3 Interrupts

Using the interrupts of this peripheral requires the interrupt controller to be configured first.

### Related Links

- [13. CPUINT - CPU Interrupt Controller](#)
- [8.7.3 SREG](#)
- [23.6 Interrupts](#)

#### 23.2.3.4 Events

The events of this peripheral are connected to the Event System.

### Related Links

- [14. EVSYS - Event System](#)

#### 23.2.3.5 Debug Operation

When run-time debugging, this peripheral will continue normal operation. Halting the CPU in Debugging mode will halt normal operation of the peripheral.

This peripheral can be forced to operate with halted CPU by writing a '1' to the Debug Run bit (DBGRUN) in the Debug Control register of the peripheral (*peripheral.DBGCTRL*).

### Related Links

- [33. UPDI - Unified Program and Debug Interface](#)

## 23.3 RTC Functional Description

The RTC peripheral offers two timing functions: the Real-Time Counter (RTC) and a Periodic Interrupt Timer (PIT). This subsection describes the RTC.

### Related Links

[23.4 PIT Functional Description](#)

### 23.3.1 Initialization

To operate the RTC, the source clock for the RTC counter must be configured before enabling the RTC peripheral, and the desired actions (interrupt requests, output Events).

### Related Links

[10. CLKCTRL - Clock Controller](#)

[23.4 PIT Functional Description](#)

#### 23.3.1.1 Configure the Clock CLK\_RTC

To configure CLK\_RTC, follow these steps:

1. Configure the desired oscillator to operate as required, in the Clock Controller peripheral (CLKCTRL).
2. Write the Clock Select bits (CLKSEL) in the Clock Selection register (RTC.CLKSEL) accordingly.

The CLK\_RTC clock configuration is used by both RTC and PIT functionality.

#### 23.3.1.2 Configure RTC

To operate the RTC, follow these steps:

1. Set the compare value in the Compare register (RTC.CMP), and/or the overflow value in the Top register (RTC.PER).
2. Enable the desired interrupts by writing to the respective Interrupt Enable bits (CMP, OVF) in the Interrupt Control register (RTC.INTCTRL).
3. Configure the RTC internal prescaler and enable the RTC by writing the desired value to the PRESCALER bit field and a '1' to the RTC Enable bit (RTCEN) in the Control A register (RTC.CTRLA).

**Note:** The RTC peripheral is used internally during device start-up. Always check the Busy bits in the RTC.STATUS and RTC.PITSTATUS registers, also on initial configuration.

### 23.3.2 Operation - RTC

#### 23.3.2.1 Enabling, Disabling, and Resetting

The RTC is enabled by setting the Enable bit in the Control A register (ENABLE bit in RTC.CTRLA to 1). The RTC is disabled by writing ENABLE bit in RTC.CTRLA to 0.

## 23.4 PIT Functional Description

The RTC peripheral offers two timing functions: the Real-Time Counter (RTC) and a Periodic Interrupt Timer (PIT). This subsection describes the PIT.

### Related Links

[23.3 RTC Functional Description](#)

### 23.4.1 Initialization

To operate the PIT, follow these steps:

1. Configure the RTC clock CLK\_RTC as described in [23.3.1.1 Configure the Clock CLK\\_RTC](#).
2. Enable the interrupt by writing a '1' to the Periodic Interrupt bit (PI) in the PIT Interrupt Control register (RTC.PITINTCTRL).
3. Select the period for the interrupt and enable the PIT by writing the desired value to the PERIOD bit field and a '1' to the PIT Enable bit (PITEN) in the PIT Control A register (RTC.PITCTRLA).

**Note:** The RTC peripheral is used internally during device start-up. Always check the Busy bits in the RTC.STATUS and RTC.PITSTATUS registers, also on initial configuration.

### 23.4.2 Operation - PIT

#### 23.4.2.1 Enabling, Disabling, and Resetting

The PIT is enabled by setting the Enable bit in the PIT Control A register (the PITEN bit in RTC.PITCTRLA to 1). The PIT is disabled by writing the PITEN bit in RTC.PITCTRLA to 0.

#### 23.4.2.2 PIT Interrupt Timing

##### Timing of the First Interrupt

The PIT function and the RTC function are running off the same counter inside the prescaler, but both functions' periods can be configured independently:

- The RTC period is configured by writing the PRESCALER bit field in RTC.CTRLA.
- The PIT period is configured by writing the PERIOD bit field in RTC.PITCTRLA.

The prescaler is OFF when both functions are OFF (RTC Enable bit (RTCCEN) in RTC.CTRLA and PIT Enable bit (PITEN) in RTC.PITCTRLA are zero), but it is running (i.e. its internal counter is counting) when either function is enabled.

For this reason, the timing of the first PIT interrupt output is depending on whether the RTC function is already enabled or not:

- When RTCCEN in RTC.CTRLA is zero and PITEN in RTC.PITCTRLA is written to '1', the prescaler will start operating at the next edge of CLK\_RTC, counting from zero. The PIT interrupt output will then toggle from '0' to '1' after a  $\frac{1}{2}$  period.
- When the RTC function is already enabled (RTCCEN is '1'), the prescaler is already running. The timing of the first interrupt output from the PIT depends on the value of the counter when the prescaler is enabled. Since the application can't access that value, the first interrupt output may occur anytime between writing PITEN to '1' and up to a full PIT period after.

##### Continuous Operation

After the first interrupt output, the PIT will continue toggling every  $\frac{1}{2}$  PIT period, resulting in a full PIT period signal.

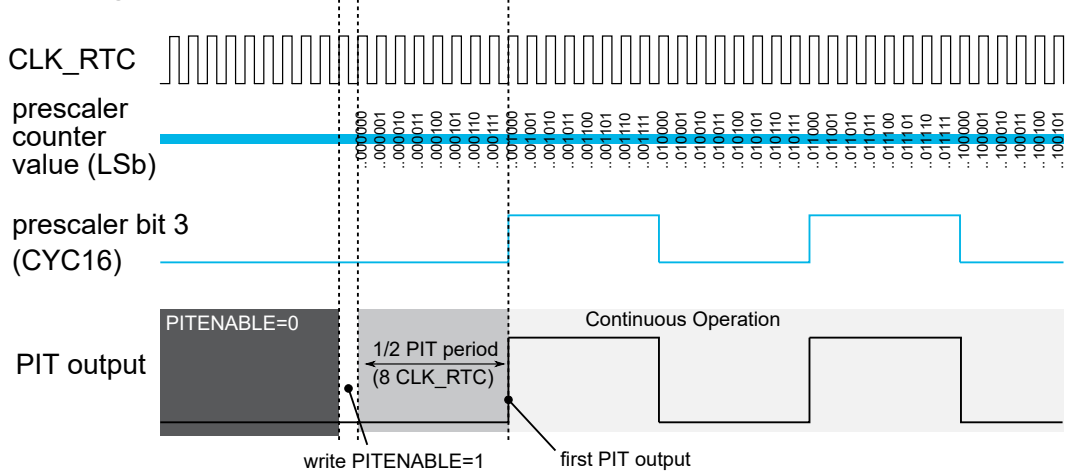
##### Example 23-1. PIT Timing Diagram for PERIOD=CYC16

For PERIOD=CYC16 in RTC.PITCTRLA, the PIT output effectively follows the state of prescaler counter bit 3, so the resulting interrupt output has a period of 16 CLK\_RTC cycles.

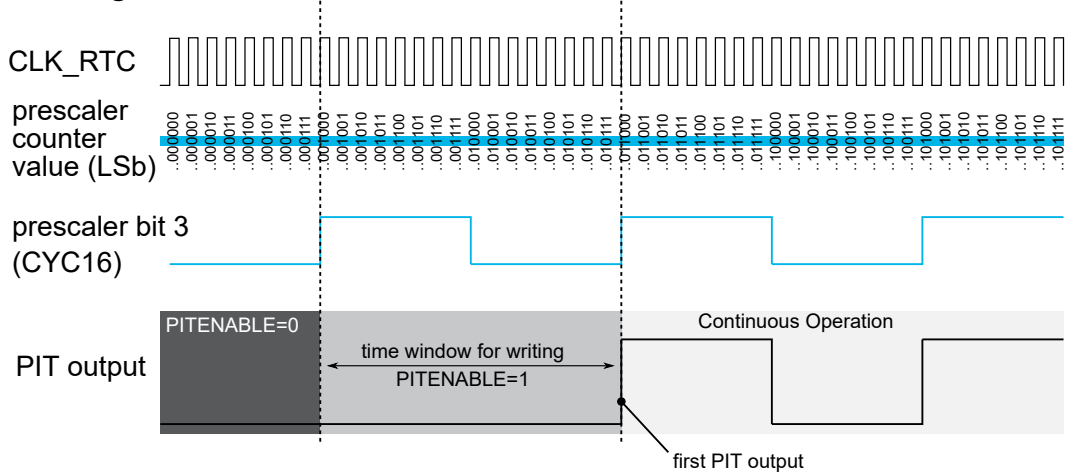
When both RTC and PIT functions are disabled, the prescaler is OFF. The delay between writing PITEN to '1' and the first interrupt output is always  $\frac{1}{2}$  PIT period, with an uncertainty of one leading CLK\_RTC cycle.

When the RTC and hence the prescaler are already enabled with any  $\text{PRESCALER}=\text{DIV}_n$ , the time between writing  $\text{PITEN}$  to '1' and the first PIT interrupt can vary between virtually 0 and a full PIT period of 16  $\text{CLK\_RTC}$  cycles. The precise delay between enabling the PIT and its first output is depending on the prescaler's counting phase: the depicted first interrupt in the lower figure is produced by writing  $\text{PITEN}$  to '1' at any time inside the leading time window.

**Figure 23-2. Timing Between PIT Enable and First Interrupt**  
**Enabling PIT with RTC/Prescaler Disabled**



**Enabling PIT with RTC/Prescaler Enabled**



### 23.5 Events

The RTC, when enabled, will generate the following output events:

- Overflow (OVF): Generated when the counter has reached its top value and wrapped to zero. The generated strobe is synchronous with  $\text{CLK\_RTC}$  and lasts one  $\text{CLK\_RTC}$  cycle.
- Compare (CMP): Indicates a match between the counter value and the Compare register. The generated strobe is synchronous with  $\text{CLK\_RTC}$  and lasts one  $\text{CLK\_RTC}$  cycle.

When enabled, the PIT generates the following 50% duty cycle clock signals on its event outputs:

- Event 0: Clock period = 8192 RTC clock cycles
- Event 1: Clock period = 4096 RTC clock cycles
- Event 2: Clock period = 2048 RTC clock cycles
- Event 3: Clock period = 1024 RTC clock cycles
- Event 4: Clock period = 512 RTC clock cycles
- Event 5: Clock period = 256 RTC clock cycles
- Event 6: Clock period = 128 RTC clock cycles
- Event 7: Clock period = 64 RTC clock cycles

The event users are configured by the Event System (EVSYS).

### Related Links

[14. EVSYS - Event System](#)

## 23.6 Interrupts

**Table 23-2. Available Interrupt Vectors and Sources**

Offset	Name	Vector Description	Conditions
0x00	RTC	Real-time counter overflow and compare match interrupt	<ul style="list-style-type: none"> <li>• Overflow (OVF): The counter has reached its top value and wrapped to zero.</li> <li>• Compare (CMP): Match between the counter value and the compare register.</li> </ul>
0x02	PIT	Periodic Interrupt Timer interrupt	A time period has passed, as configured in RTC_PITCTRLA.PERIOD.

When an interrupt condition occurs, the corresponding interrupt flag is set in the Interrupt Flags register of the peripheral (*peripheral*.INTFLAGS).

An interrupt source is enabled or disabled by writing to the corresponding enable bit in the peripheral's Interrupt Control register (*peripheral*.INTCTRL).

An interrupt request is generated when the corresponding interrupt source is enabled and the interrupt flag is set. The interrupt request remains active until the interrupt flag is cleared. See the peripheral's INTFLAGS register for details on how to clear interrupt flags.

### Related Links

[13. CPUINT - CPU Interrupt Controller](#)

[23.11.3 INTCTRL](#)

[23.11.13 PITINTCTRL](#)

## 23.7 Sleep Mode Operation

The RTC will continue to operate in Idle Sleep mode. It will run in Standby Sleep mode if the RUNSTDBY bit in RTC.CTRLA is set.

The PIT will continue to operate in any sleep mode.

### Related Links

### 23.11.1 CTRLA

## 23.8 Synchronization

Both the RTC and the PIT are asynchronous, operating from a different clock source (CLK\_RTC) independently of the main clock (CLK\_PER). For Control and Count register updates, it will take a number of RTC clock and/or peripheral clock cycles before an updated register value is available in a register or until a configuration change has an effect on the RTC or PIT, respectively. This synchronization time is described for each register in the Register Description section.

For some RTC registers, a Synchronization Busy flag is available (CMPBUSY, PERBUSY, CNTBUSY, CTRLABUSY) in the STATUS register (RTC.STATUS).

For the RTC.PITCTRLA register, a Synchronization Busy flag (SYNCBUSY) is available in the PIT STATUS register (RTC.PITSTATUS).

Check for busy should be performed before writing to the mentioned registers.

### Related Links

[10. CLKCTRL - Clock Controller](#)

## 23.9 Configuration Change Protection

Not applicable.

### 23.10 Register Summary - RTC

Offset	Name	Bit Pos.							
0x00	<a href="#">CTRLA</a>	7:0	RUNSTDBY	PRESCALER[3:0]					RTCEN
0x01	<a href="#">STATUS</a>	7:0				CMPBUSY	PERBUSY	CNTBUSY	CTRLABUSY
0x02	<a href="#">INTCTRL</a>	7:0						CMP	OVF
0x03	<a href="#">INTFLAGS</a>	7:0						CMP	OVF
0x04	<a href="#">TEMP</a>	7:0	TEMP[7:0]						
0x05	<a href="#">DBGCTRL</a>	7:0							DBGRUN
0x06	Reserved								
0x07	<a href="#">CLKSEL</a>	7:0						CLKSEL[1:0]	
0x08	<a href="#">CNT</a>	7:0	CNT[7:0]						
		15:8	CNT[15:8]						
0x0A	<a href="#">PER</a>	7:0	PER[7:0]						
		15:8	PER[15:8]						
0x0C	<a href="#">CMP</a>	7:0	CMP[7:0]						
		15:8	CMP[15:8]						
0x0E ...	Reserved								
0x0F									
0x10	<a href="#">PITCTRLA</a>	7:0		PERIOD[3:0]					PITEN
0x11	<a href="#">PITSTATUS</a>	7:0							CTRLBUSY
0x12	<a href="#">PITINTCTRL</a>	7:0							PI
0x13	<a href="#">PITINTFLAGS</a>	7:0							PI
0x14	Reserved								
0x15	<a href="#">PITDBGCTRL</a>	7:0							DBGRUN

### 23.11 Register Description



### 23.11.1 Control A

**Name:** CTRLA  
**Offset:** 0x00  
**Reset:** 0x00  
**Property:** -

Bit	7	6	5	4	3	2	1	0
	RUNSTDBY	PRESCALER[3:0]						RTCEN
Access	R/W	R/W	R/W	R/W	R/W			R/W
Reset	0	0	0	0	0			0

#### Bit 7 – RUNSTDBY Run in Standby

Value	Description
0	RTC disabled in Standby Sleep mode
1	RTC enabled in Standby Sleep mode

#### Bits 6:3 – PRESCALER[3:0] Prescaler

These bits define the prescaling of the CLK\_RTC clock signal. Due to synchronization between the RTC clock and system clock domains, there is a latency of two RTC clock cycles from updating the register until this has an effect. Application software needs to check that the CTRLABUSY flag in RTC.STATUS is cleared before writing to this register.

Value	Name	Description
0x0	DIV1	RTC clock/1 (no prescaling)
0x1	DIV2	RTC clock/2
0x2	DIV4	RTC clock/4
0x3	DIV8	RTC clock/8
0x4	DIV16	RTC clock/16
0x5	DIV32	RTC clock/32
0x6	DIV64	RTC clock/64
0x7	DIV128	RTC clock/128
0x8	DIV256	RTC clock/256
0x9	DIV512	RTC clock/512
0xA	DIV1024	RTC clock/1024
0xB	DIV2048	RTC clock/2048
0xC	DIV4096	RTC clock/4096
0xD	DIV8192	RTC clock/8192
0xE	DIV16384	RTC clock/16384
0xF	DIV32768	RTC clock/32768

#### Bit 0 – RTCEN RTC Enable

Value	Description
0	RTC disabled
1	RTC enabled

### 23.11.2 Status

**Name:** STATUS  
**Offset:** 0x01  
**Reset:** 0x00  
**Property:** -

	7	6	5	4	3	2	1	0
Bit					CMPBUSY	PERBUSY	CNTBUSY	CTRLABUSY
Access					R	R	R	R
Reset					0	0	0	0

**Bit 3 – CMPBUSY** Compare Synchronization Busy

This bit is indicating whether the RTC is busy synchronizing the Compare register (RTC.CMP) in RTC clock domain.

**Bit 2 – PERBUSY** Period Synchronization Busy

This bit is indicating whether the RTC is busy synchronizing the Period register (RTC.PER) in RTC clock domain.

**Bit 1 – CNTBUSY** Counter Synchronization Busy

This bit is indicating whether the RTC is busy synchronizing the Count register (RTC.CNT) in RTC clock domain.

**Bit 0 – CTRLABUSY** Control A Synchronization Busy

This bit is indicating whether the RTC is busy synchronizing the Control A register (RTC.CTRLA) in RTC clock domain.

**23.11.3 Interrupt Control**

**Name:** INTCTRL  
**Offset:** 0x02  
**Reset:** 0x00  
**Property:** -

Bit	7	6	5	4	3	2	1	0
							CMP	OVF
Access							R/W	R/W
Reset							0	0

**Bit 1 – CMP** Compare Match Interrupt Enable  
Enable interrupt-on-compare match (i.e., when the Counter value (CNT) matches the Compare value (CMP)).

**Bit 0 – OVF** Overflow Interrupt Enable  
Enable interrupt-on-counter overflow (i.e., when the Counter value (CNT) matched the Period value (PER) and wraps around to zero).

### 23.11.4 Interrupt Flag

**Name:** INTFLAGS  
**Offset:** 0x03  
**Reset:** 0x00  
**Property:** -

	7	6	5	4	3	2	1	0
Bit							CMP	OVF
Access							R	R
Reset							0	0

**Bit 1 – CMP** Compare Match Interrupt Flag

This flag is set when the Counter value (CNT) matches the Compare value (CMP).

Writing a '1' to this bit clears the flag.

**Bit 0 – OVF** Overflow Interrupt Flag

This flag is set when the Counter value (CNT) has reached the Period value (PER) and wrapped to zero.

Writing a '1' to this bit clears the flag.

**23.11.5 Temporary**

**Name:** TEMP  
**Offset:** 0x4  
**Reset:** 0x00  
**Property:** -

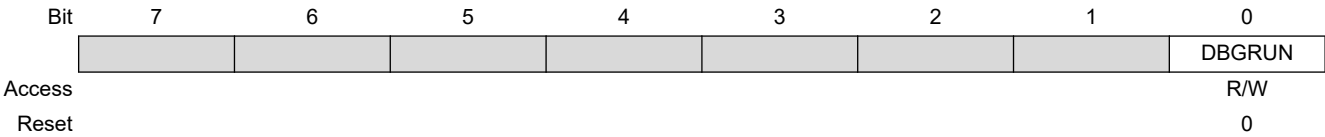
The Temporary register is used by the CPU for single-cycle, 16-bit access to the 16-bit registers of this peripheral. It can be read and written by software. Refer to 16-bit access in the AVR CPU chapter. There is one common Temporary register for all the 16-bit registers of this peripheral.

Bit	7	6	5	4	3	2	1	0
	TEMP[7:0]							
Access	R/W	R/W	R/W	R/W	R/W	R/W	R/W	R/W
Reset	0	0	0	0	0	0	0	0

**Bits 7:0 – TEMP[7:0]** Temporary  
Temporary register for read/write operations in 16-bit registers.

**23.11.6 Debug Control**

**Name:** DBGCTRL  
**Offset:** 0x05  
**Reset:** 0x00  
**Property:** -



**Bit 0 – DBGRUN** Debug Run

Value	Description
0	The peripheral is halted in Break Debug mode and ignores events
1	The peripheral will continue to run in Break Debug mode when the CPU is halted

### 23.11.7 Clock Selection

**Name:** CLKSEL  
**Offset:** 0x07  
**Reset:** 0x00  
**Property:** -

	Bit	7	6	5	4	3	2	1	0
		CLKSEL[1:0]							
Access								R/W	R/W
Reset								0	0

**Bits 1:0 – CLKSEL[1:0]** Clock Select

Writing these bits select the source for the RTC clock (CLK\_RTC).

When configuring the RTC to use either XOSC32K or the external clock on TOSC1, XOSC32K needs to be enabled and the Source Select bit (SEL) and Run Standby bit (RUNSTDBY) in the XOSC32K Control A register of the Clock Controller (CLKCTRL.XOSC32KCTRLA) must be configured accordingly.

Value	Name	Description
0x0	INT32K	32.768 kHz from OSCULP32K
0x1	INT1K	1.024 kHz from OSCULP32K
0x2	TOSC32K	32.768 kHz from XOSC32K or external clock from TOSC1
0x3	EXTCLK	External clock from EXTCLK pin

### 23.11.8 Count

**Name:** CNT  
**Offset:** 0x08  
**Reset:** 0x00  
**Property:** -

The RTC.CNTL and RTC.CNTH register pair represents the 16-bit value, CNT. The low byte [7:0] (suffix L) is accessible at the original offset. The high byte [15:8] (suffix H) can be accessed at offset + 0x01. For more details on reading and writing 16-bit registers, refer to Accessing 16-bit Registers in the CPU chapter.

Due to synchronization between the RTC clock and system clock domains, there is a latency of two RTC clock cycles from updating the register until this has an effect. Application software needs to check that the CNTBUSY flag in RTC.STATUS is cleared before writing to this register.

	Bit	15	14	13	12	11	10	9	8
		CNT[15:8]							
Access		R/W	R/W	R/W	R/W	R/W	R/W	R/W	R/W
Reset		0	0	0	0	0	0	0	0
	Bit	7	6	5	4	3	2	1	0
		CNT[7:0]							
Access		R/W	R/W	R/W	R/W	R/W	R/W	R/W	R/W
Reset		0	0	0	0	0	0	0	0

**Bits 15:8 – CNT[15:8] Counter High Byte**

These bits hold the MSB of the 16-bit Counter register.

**Bits 7:0 – CNT[7:0] Counter Low Byte**

These bits hold the LSB of the 16-bit Counter register.



### 23.11.9 Period

**Name:** PER  
**Offset:** 0x0A  
**Reset:** 0xFF  
**Property:** -

The RTC.PERL and RTC.PERH register pair represents the 16-bit value, PER. The low byte [7:0] (suffix L) is accessible at the original offset. The high byte [15:8] (suffix H) can be accessed at offset + 0x01. For more details on reading and writing 16-bit registers, refer to Accessing 16-bit Registers in the CPU chapter.

Due to synchronization between the RTC clock and system clock domains, there is a latency of two RTC clock cycles from updating the register until this has an effect. Application software needs to check that the PERBUSY flag in RTC.STATUS is cleared before writing to this register.

	Bit	15	14	13	12	11	10	9	8
		PER[15:8]							
Access		R/W	R/W	R/W	R/W	R/W	R/W	R/W	R/W
Reset		1	1	1	1	1	1	1	1
	Bit	7	6	5	4	3	2	1	0
		PER[7:0]							
Access		R/W	R/W	R/W	R/W	R/W	R/W	R/W	R/W
Reset		1	1	1	1	1	1	1	1

**Bits 15:8 – PER[15:8] Period High Byte**

These bits hold the MSB of the 16-bit Period register.

**Bits 7:0 – PER[7:0] Period Low Byte**

These bits hold the LSB of the 16-bit Period register.

### 23.11.10 Compare

**Name:** CMP  
**Offset:** 0x0C  
**Reset:** 0x00  
**Property:** -

The RTC.CMPL and RTC.CMPH register pair represents the 16-bit value, CMP. The low byte [7:0] (suffix L) is accessible at the original offset. The high byte [15:8] (suffix H) can be accessed at offset + 0x01. For more details on reading and writing 16-bit registers, refer to Accessing 16-bit Registers in the CPU chapter.

	Bit	15	14	13	12	11	10	9	8
	CMP[15:8]								
Access	R/W	R/W	R/W	R/W	R/W	R/W	R/W	R/W	R/W
Reset	0	0	0	0	0	0	0	0	0
	Bit	7	6	5	4	3	2	1	0
	CMP[7:0]								
Access	R/W	R/W	R/W	R/W	R/W	R/W	R/W	R/W	R/W
Reset	0	0	0	0	0	0	0	0	0

**Bits 15:8 – CMP[15:8]** Compare High Byte  
 These bits hold the MSB of the 16-bit Compare register.

**Bits 7:0 – CMP[7:0]** Compare Low Byte  
 These bits hold the LSB of the 16-bit Compare register.

### 23.11.11 Periodic Interrupt Timer Control A

**Name:** PITCTRLA  
**Offset:** 0x10  
**Reset:** 0x00  
**Property:** -

Bit	7	6	5	4	3	2	1	0	
	PERIOD[3:0]								PITEN
Access		R/W	R/W	R/W	R/W			R/W	
Reset		0	0	0	0			0	

#### Bits 6:3 – PERIOD[3:0] Period

Writing this bit field selects the number of RTC clock cycles between each interrupt.

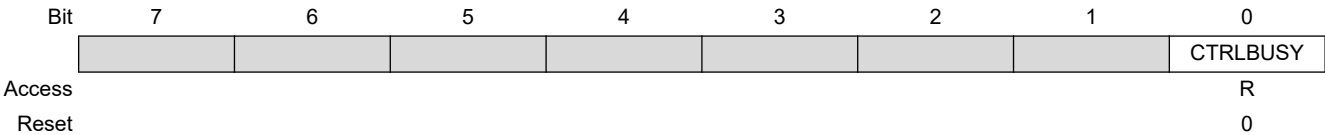
Value	Name	Description
0x0	OFF	No interrupt
0x1	CYC4	4 cycles
0x2	CYC8	8 cycles
0x3	CYC16	16 cycles
0x4	CYC32	32 cycles
0x5	CYC64	64 cycles
0x6	CYC128	128 cycles
0x7	CYC256	256 cycles
0x8	CYC512	512 cycles
0x9	CYC1024	1024 cycles
0xA	CYC2048	2048 cycles
0xB	CYC4096	4096 cycles
0xC	CYC8192	8192 cycles
0xD	CYC16384	16384 cycles
0xE	CYC32768	32768 cycles
0xF	-	Reserved

#### Bit 0 – PITEN Periodic Interrupt Timer Enable

Writing a '1' to this bit enables the periodic interrupt timer.

**23.11.12 Periodic Interrupt Timer Status**

**Name:** PITSTATUS  
**Offset:** 0x11  
**Reset:** 0x00  
**Property:** -



**Bit 0 – CTRLBUSY** PITCTRLA Synchronization Busy  
This bit indicates whether the RTC is busy synchronizing the Periodic Interrupt Timer Control A register (RTC.PITCTRLA) in the RTC clock domain.

### 23.11.13 PIT Interrupt Control

**Name:** PITINTCTRL  
**Offset:** 0x12  
**Reset:** 0x00  
**Property:** -

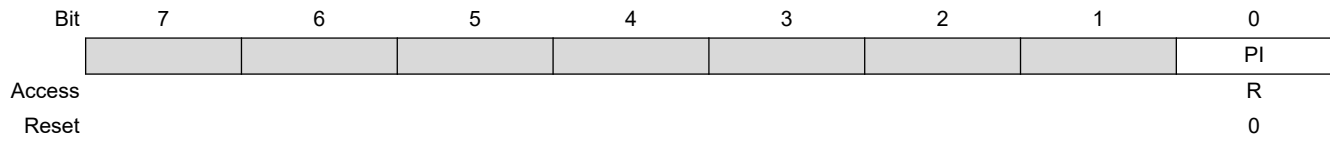
Bit	7	6	5	4	3	2	1	0									
	<table border="1" style="width: 100%; height: 20px; border-collapse: collapse;"> <tr> <td style="width: 12.5%;"></td> <td style="width: 12.5%;"></td> <td style="width: 12.5%;"></td> <td style="width: 12.5%;"></td> <td style="width: 12.5%;"></td> <td style="width: 12.5%;"></td> <td style="width: 12.5%;"></td> <td style="width: 12.5%;"></td> <td style="width: 12.5%;"></td> </tr> </table>																PI
Access								R/W									
Reset								0									

#### Bit 0 – PI Periodic interrupt

Value	Description
0	The periodic interrupt is disabled
1	The periodic interrupt is enabled

### 23.11.14 PIT Interrupt Flag

**Name:** PITINTFLAGS  
**Offset:** 0x13  
**Reset:** 0x00  
**Property:** -



**Bit 0 – PI** Periodic interrupt Flag

This flag is set when a periodic interrupt is issued.

Writing a '1' clears the flag.

### 23.11.15 Periodic Interrupt Timer Debug Control

**Name:** PITDBGCTRL  
**Offset:** 0x15  
**Reset:** 0x00  
**Property:** -

	7	6	5	4	3	2	1	0
								DBGRUN
Access								R/W
Reset								0

**Bit 0 – DBGRUN** Debug Run

Writing this bit to '1' will enable the PIT to run in Debug mode while the CPU is halted.

Value	Description
0	The peripheral is halted in Break Debug mode and ignores events
1	The peripheral will continue to run in Break Debug mode when the CPU is halted

## 24. USART - Universal Synchronous and Asynchronous Receiver and Transmitter

### 24.1 Features

- Full-Duplex or One-Wire Half-Duplex Operation
- Asynchronous or Synchronous Operation:
  - Synchronous clock rates up to 1/2 of the device clock frequency
  - Synchronous Slave clock rates up to 1/4 of the device clock frequency
  - Asynchronous clock rates up to 1/8 of the device clock frequency
- Supports Serial Frames with:
  - 5, 6, 7, 8, or 9 data bits
  - Optionally even and odd parity bits
  - 1 or 2 Stop bits
- Fractional Baud Rate Generator:
  - Can generate desired baud rate from any system clock frequency
  - No need for an external oscillator with certain frequencies
- Built-In Error Detection and Correction Schemes:
  - Odd or even parity generation and parity check
  - Data overrun and framing error detection
  - Noise filtering includes false Start bit detection and digital low-pass filter
- Separate Interrupts for:
  - Transmit complete
  - Transmit Data register empty
  - Receive complete
- Multiprocessor Communication mode:
  - Addressing scheme to address specific devices on a multi-device bus
  - Enable unaddressed devices to automatically ignore all frames
- Start Frame Detection in UART mode
- Master SPI mode:
  - Double-buffered operation
  - Configurable data order
  - Operation up to 1/2 of the peripheral clock frequency
- I<sup>2</sup>C Module for IrDA<sup>®</sup> Compliant Pulse Modulation/Demodulation
- LIN Slave Support:
  - Auto-baud and Break character detection
- RS-485 Support

### 24.2 Overview

The Universal Synchronous and Asynchronous serial Receiver and Transmitter (USART) peripheral is a fast and flexible serial communication module. The USART supports full duplex communication,



asynchronous and synchronous operation and one-wire configurations. The USART can be set in SPI Master mode and used for SPI communication.

The USART uses three communication lines for data transfer:

- RxD for receiving
- TxD for transmitting
- XCK for the transmission clock in synchronous operation

Communication is frame based, and the frame format can be customized to support a wide range of standards. One frame can be directly followed by a new frame, or the communication line can return to the idle (high) state. A serial frame consists of:

- 1 Start bit
- 5, 6, 7, 8, or 9 data bits (MSB or LSB first)
- Parity bit: Even, odd, or none
- 1 or 2 Stop bits

The USART is buffered in both directions, enabling continued data transmission without any delay between frames. Separate interrupts for receive and transmit completion allow fully interrupt driven communication. Frame error and buffer overflow are detected in hardware and indicated with separate status flags. Even or odd parity generation and parity check can also be enabled.

The main functional blocks are the clock generator, the transmitter, and the receiver:

- The clock generator includes a fractional Baud Rate Generator that is able to generate a wide range of USART baud rates from any system clock frequencies. This removes the need to use an oscillator with a specific frequency to achieve a required baud rate. It also supports external clock input in synchronous slave operation.
- The transmitter consists of a single write buffer (DATA), a shift register, and a parity generator. The write buffer allows continuous data transmission without any delay between frames.
- The receiver consists of a two-level receive buffer (DATA) and a Shift register. Data and clock recovery units ensure robust synchronization and noise filtering during asynchronous data reception. It includes frame error, buffer overflow, and parity error detection.

When the USART is set in one-wire mode, the transmitter and the receiver share the same RxD I/O pin.

When the USART is set in Master SPI mode, all USART-specific logic is disabled, leaving the transmit and receive buffers, Shift registers, and Baud Rate Generator enabled. Pin control and interrupt generation are identical in both modes. The registers are used in both modes, but their functionality differs for some control settings.

An IRCOM module can be enabled for one USART to support IrDA 1.4 physical compliant pulse modulation and demodulation for baud rates up to 115.2 kbps.

The USART can be linked to the Configurable Custom Logic unit (CCL). When used with the CCL, the TxD/RxD data can be encoded/decoded before the signal is fed into the USART receiver or after the signal is output from the transmitter when the USART is connected to CCL LUT outputs.

This device provides one instance of the USART peripheral, USART0.

### 24.2.1 Signal Description

Signal	Type	Description
RxD	Input/output	Receiving line
TxD	Output	Transmitting line
XCK	Input/output	Clock for synchronous operation
XDIR	Output	Transmit Enable for RS485

#### Related Links

[5. I/O Multiplexing and Considerations](#)

### 24.2.2 System Dependencies

In order to use this peripheral, other parts of the system must be configured correctly, as described below.

**Table 24-1. USART System Dependencies**

Dependency	Applicable	Peripheral
Clocks	Yes	CLKCTRL
I/O Lines and Connections	Yes	PORT
Interrupts	Yes	CPUINT
Events	Yes	EVSYS
Debug	Yes	UPDI

#### Related Links

[24.2.2.5 Debug Operation](#)

[24.2.2.1 Clocks](#)

[24.2.2.2 I/O Lines and Connections](#)

[24.2.2.3 Interrupts](#)

[24.2.2.4 Events](#)

#### 24.2.2.1 Clocks

This peripheral depends on the peripheral clock.

#### Related Links

[10. CLKCTRL - Clock Controller](#)

#### 24.2.2.2 I/O Lines and Connections

Using the I/O lines of the peripheral requires configuration of the I/O pins.

#### Related Links

[16. PORT - I/O Pin Configuration](#)

[5. I/O Multiplexing and Considerations](#)

#### 24.2.2.3 Interrupts

Using the interrupts of this peripheral requires the interrupt controller to be configured first.

#### Related Links

[13. CPUINT - CPU Interrupt Controller](#)

[8.7.3 SREG](#)

[24.3.4 Interrupts](#)

#### **24.2.2.4 Events**

The events of this peripheral are connected to the Event System.

##### **Related Links**

[14. EVSYS - Event System](#)

#### **24.2.2.5 Debug Operation**

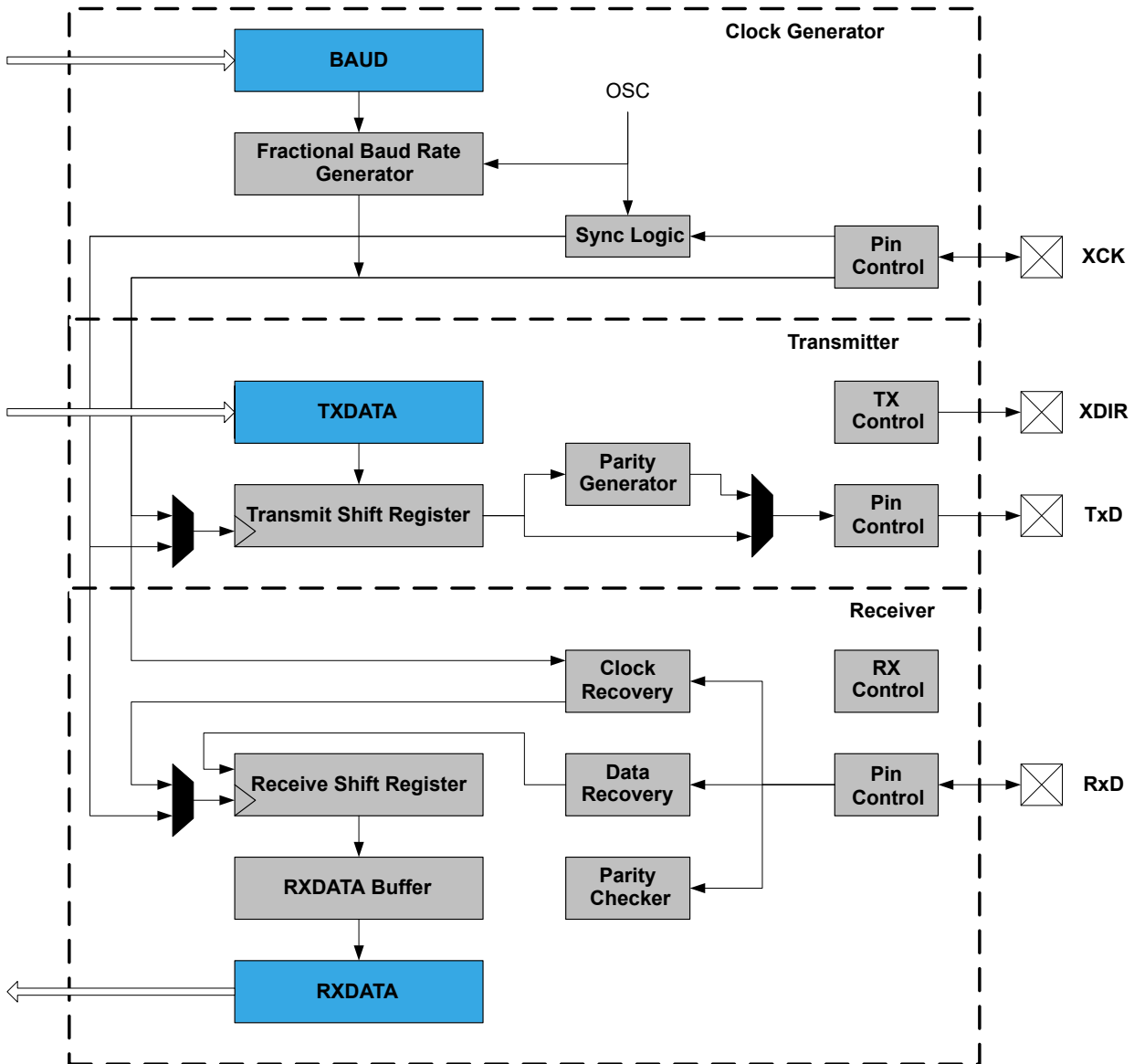
When the CPU is halted in Debug mode, this peripheral will continue normal operation. If the peripheral is configured to require periodical service by the CPU through interrupts or similar, improper operation or data loss may result during debugging. This peripheral can be forced to halt operation during debugging.

##### **Related Links**

[33. UPDI - Unified Program and Debug Interface](#)

### 24.2.2.6 Block Diagram

Figure 24-1. USART Block Diagram



## 24.3 Functional Description

### 24.3.1 Initialization

For setting the USART in Full-Duplex mode, the following initialization sequence is recommended:

1. Set the TxD pin value high, and optionally set the XCK pin low (OUT[n] in PORTx.OUT).
2. Set the TxD and optionally the XCK pin as an output (DIR[n] in PORTx.DIR).
3. Set the baud rate (in the USARTn.BAUD register) and frame format.
4. Set the mode of operation (enables XCK pin output in Synchronous mode).
5. Enable the transmitter or the receiver, depending on the usage.

For interrupt-driven USART operation, global interrupts should be disabled during the initialization.

Before doing a re-initialization with a changed baud rate or frame format, be sure that there are no ongoing transmissions while the registers are changed.

For setting the USART in One-Wire mode, the following initialization sequence is recommended:

1. Set the TxD/RxD pin value high, and optionally set the XCK pin low.
2. Optionally, write the ODME bit in the USARTn.CTRLB register to '1' for Wired-AND functionality.
3. Set the TxD/RxD and optionally the XCK pin as an output.
4. Select the baud rate and frame format.
5. Select the mode of operation (enables XCK pin output in Synchronous mode).
6. Enable the transmitter or the receiver, depending on the usage.

For interrupt-driven USART operation, global interrupts should be disabled during the initialization.

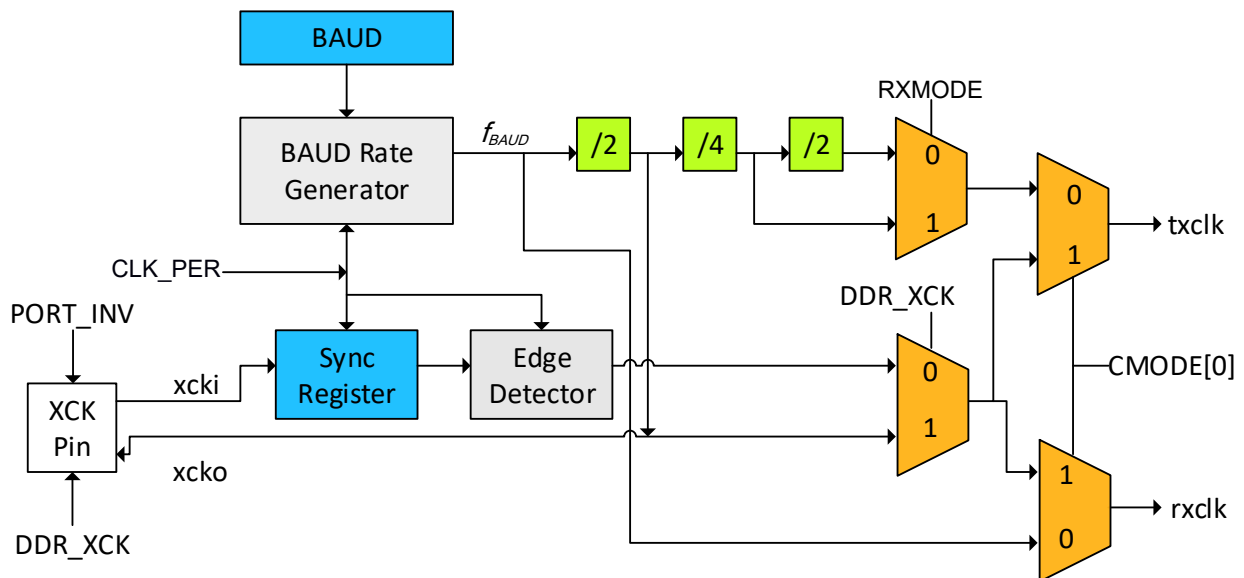
Before doing a re-initialization with a changed baud rate or frame format, be sure that there are no ongoing transmissions while the registers are changed.

### 24.3.2 Operation

#### 24.3.2.1 Clock Generation

The clock used for baud rate generation and for shifting and sampling data bits is generated internally by the fractional Baud Rate Generator or externally from the transfer clock (XCK) pin. Five modes of clock generation are supported; Normal and Double-Speed Asynchronous mode, Master and Slave Synchronous mode, and Master SPI mode.

**Figure 24-2. Clock Generation Logic Block Diagram**



##### 24.3.2.1.1 Internal Clock Generation - The Fractional Baud Rate Generator

The Baud Rate Generator is used for internal clock generation for Asynchronous modes, Synchronous master mode, and Master SPI mode operation. The output frequency generated ( $f_{BAUD}$ ) is determined by the baud register value (BAUD) and the peripheral clock frequency ( $f_{CLK\_PER}$ ).

In Asynchronous mode, the BAUD register value uses all 16 bits. The 10 msb (BAUD[15:6]) hold the integer part, while the 6 lsb (BAUD[5:0]) hold the fractional part. Non-standard BAUD frequencies can result in fractional parts, which if ignored introduce an error in the approximation to the desired BAUD frequency. The BAUD fractional part is used to reduce this error by adjusting the sampling point. BAUD

register values below 64 are not supported, as the integer part needs to be at least 1. The integer part valid range is therefore 64 to 65535.

In Synchronous mode, only the 10-bit integer part of the BAUD register, i.e. BAUD[15:6], determine the baud rate. The fractional part must be written to zero.

The following table lists equations for translating between BAUD register values and baud rates. The equations take BAUD register bit width and fractional interpretation into consideration. The BAUD register values calculated with these equations can be written directly to the BAUD register without any additional scaling. Resulting rounding errors will contribute to baud rate frequency errors.

**Table 24-2. Equations for Calculating Baud Rate Register Setting**

Operating Mode	Conditions	Baud Rate ( $f_{BAUD}$ , Bits Per Seconds)	USART.BAUD Register Value Calculation
Asynchronous	$f_{BAUD} \leq \frac{f_{CLK\_PER}}{S}$ $USART.BAUD \geq 64$	$\frac{f_{CLK\_PER}}{S \times BAUD} \times 2^6$	$round\left(\frac{f_{CLK\_PER}}{S \times f_{BAUD}} \times 2^6\right)$
Synchronous	$f_{BAUD} \leq \frac{f_{CLK\_PER}}{2}$	$\frac{f_{CLK\_PER}}{2 \times BAUD} \times 2^6$	$round\left(\frac{f_{CLK\_PER}}{2 \times f_{BAUD}}\right) \times 2^6$

S = 16 if in Receiver mode (USART.CTRLB, RXMODE) is configured as NORMAL, and S = 8 if configured as CLK2X. S determines the number of samples taken for each USART symbol.

### 24.3.2.1.2 Synchronous Slave External Clock limitations

An External clock (XCK) is used in Synchronous Slave mode operation. The XCK clock input is sampled on the peripheral clock frequency and the maximum XCK clock frequency ( $f_{XCK}$ ) is limited by the following:

The USART will perform clock recovery on the external clock (XCK) signal when configured in Synchronous Slave mode, configuring the BAUD register will therefore have no impact on the transfer speed. The XCK signal must be sampled twice for each rising and falling edge to achieve successful clock recovery. The maximum XCK speed in Synchronous operation mode is therefore limited by the following:

$$f_{slave\_XCK} < \frac{f_{CLK\_PER}}{4}$$

If the XCK clock has jitter, or if the high/low period duty cycle is not 50/50, the maximum XCK clock speed must be reduced accordingly to ensure that XCK is sampled a minimum of 2 times for each edge.

### 24.3.2.1.3 Double Speed Operation

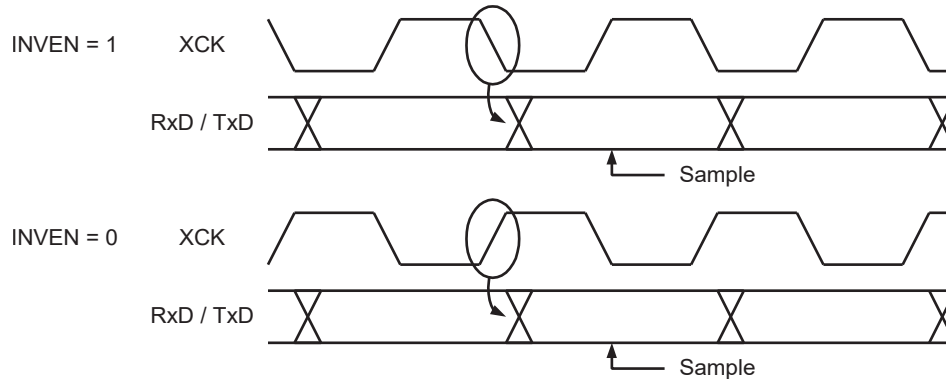
Double speed operation allows for higher baud rates under asynchronous operation with lower peripheral clock frequencies. This operation mode is enabled by writing the RXMODE bit in the Control B register (USARTn.CTRLB) to CLK2X.

When enabled, the baud rate for a given asynchronous baud rate setting shown in [Table 24-2](#) will be doubled. In this mode, the receiver will use half the number of samples (reduced from 16 to 8) for data sampling and clock recovery. This requires a more accurate baud rate setting and peripheral clock. See [24.3.2.4.6 Asynchronous Data Reception](#) for more details.

### 24.3.2.1.4 Synchronous Clock Operation

When Synchronous mode is used, the XCK pin controls whether the transmission clock is input (Slave mode) or output (Master mode). The corresponding port pin must be set to output for Master mode or to input for Slave mode (PORTx.DIR[n]). The normal port operation of the XCK pin will be overridden. The dependency between the clock edges and data sampling or data change is the same. Data input (on RxD) is sampled at the XCK clock edge which is opposite the edge where data output (TxD) is changed.

**Figure 24-3. Synchronous Mode XCK Timing**



The I/O pin can be inverted by writing a '1' to the Inverted I/O Enable bit (INVEN) in the Pin n Control register of the port peripheral (PORTx.PINnCTRL). Using the inverted I/O setting for the corresponding XCK port pin, the XCK clock edges used for data sampling and data change can be selected. If inverted I/O is disabled (INVEN=0), data will be changed at the rising XCK clock edge and sampled at the falling XCK clock edge. If inverted I/O is enabled (INVEN=1), data will be changed at the falling XCK clock edge and sampled at the rising XCK clock edge.

### 24.3.2.1.5 Master SPI Mode Clock Generation

For Master SPI mode operation, only internal clock generation is supported. This is identical to the USART Synchronous Master mode, and the baud rate or BAUD setting is calculated using the same equations (see [Table 24-2](#)).

There are four combinations of the SPI clock (SCK) phase and polarity with respect to the serial data, and these are determined by the Clock Phase bit (UCPHA) in the Control C register (USARTn.CTRLc) and the Inverted I/O Enable bit (INVEN) in the Pin n Control register of the port peripheral (PORTx.PINnCTRL). The data transfer timing diagrams are shown in [Figure 24-4](#).

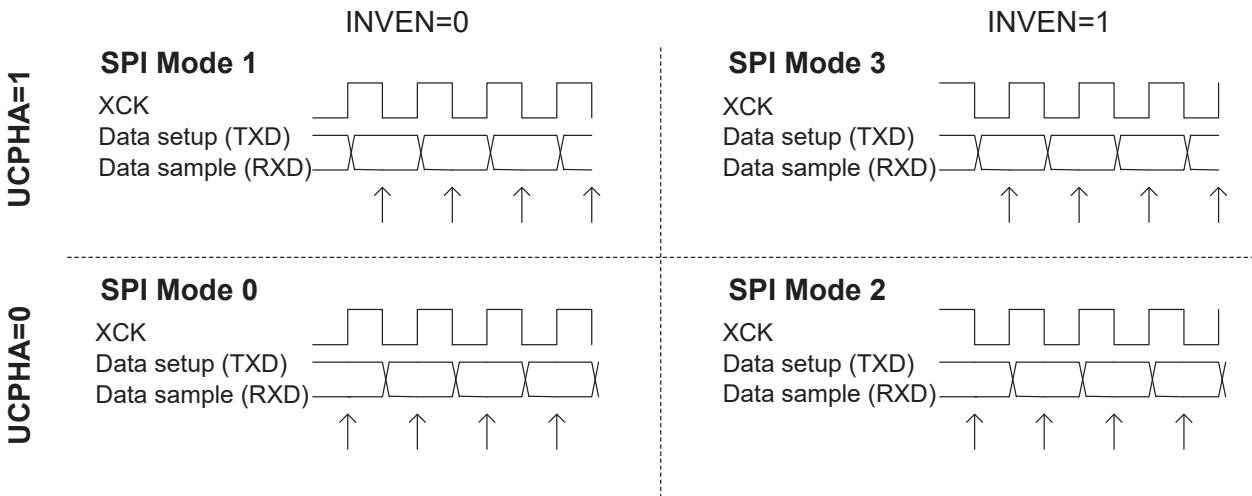
Data bits are shifted out and latched in on opposite edges of the XCK signal, ensuring sufficient time for data signals to stabilize. The settings are summarized in the table below. Changing the setting of any of these bits during transmission will corrupt both the receiver and transmitter.

**Table 24-3. Functionality of INVEN in PORTx.PINnCTRL and UCPHA in USARTn.CTRLc**

SPI Mode	INVEN	UCPHA	Leading Edge	Trailing Edge
0	0	0	Rising, sample	Falling, setup
1	0	1	Rising, setup	Falling, sample
2	1	0	Falling, sample	Rising, setup
3	1	1	Falling, setup	Rising, sample

The leading edge is the first clock edge of a clock cycle. The trailing edge is the last clock edge of a clock cycle.

**Figure 24-4. UCPHA and INVEN Data Transfer Timing Diagrams**



### Related Links

[24.5.9 CTRLC](#)

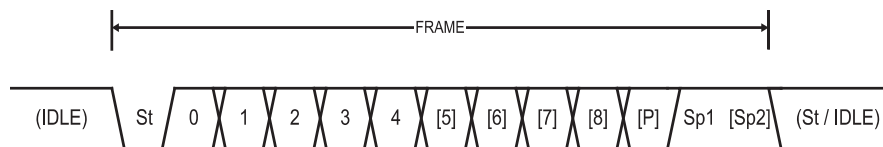
### 24.3.2.2 Frame Formats

Data transfer is frame based, where a serial frame consists of one character of data bits with synchronization bits (Start and Stop bits) and an optional parity bit for error checking. This does not apply to master SPI operation (see [24.3.2.2.2 SPI Frame Formats](#).) The USART accepts all combinations of the following as valid frame formats:

- 1 Start bit
- 5, 6, 7, 8, or 9 Data bits
- No, even, or odd Parity bit
- 1 or 2 Stop bits

[Figure 24-5](#) illustrates the possible combinations of frame formats. Bits inside brackets are optional.

**Figure 24-5. Frame Formats**



**Table 24-4. Frame Format Nomenclature**

Symbol	Meaning
St	Start bit, always low
(n)	Data bits (0 to 8)
P	Parity bit, may be odd or even
Sp	Stop bit, always high
IDLE	No transfer on the communication line (RxD or TxD). The IDLE state is always high



#### 24.3.2.2.1 Parity

Even or odd parity can be selected for error checking by writing the Parity Mode bits (PMODE) in the Control C register (USARTn.CTRLA). If even parity is selected, the parity bit is set to '1' if the number of logical '1' data bits is odd (making the total number of logical '1' even). If odd parity is selected, the parity bit is set to '1' if the number of logical '1' data bits is even (making the total number of '1's odd).

When enabled, the parity checker calculates the parity of the data bits in incoming frames and compares the result with the parity bit of the corresponding frame. If a parity error is detected, the parity error flag is set.

#### 24.3.2.2.2 SPI Frame Formats

The serial frame in SPI mode is defined to be one character of eight data bits. The USART in master SPI mode has two valid frame formats:

- 8-bit data, MSb first
- 8-bit data, LSb first

The data order is selected by writing to the Data Order bit (UDORD) in the Control C register (USARTn.CTRLA).

After a complete frame is transmitted, a new frame can directly follow it, or the communication line can return to the idle (high) state.

#### 24.3.2.3 Data Transmission - USART Transmitter

When the transmitter has been enabled, the normal port operation of the TxD pin is overridden by the USART and given the function as the transmitter's serial output. The direction of the pin n must be configured as output by writing the Direction register for the corresponding port (PORTx.DIR[n]). If the USART is configured for one-wire operation, the USART will automatically override the RXD/TxD pin to output, when the transmitter is enabled.

##### Related Links

[15. PORTMUX - Port Multiplexer](#)

[16. PORT - I/O Pin Configuration](#)

#### 24.3.2.3.1 Sending Frames

A data transmission is initiated by loading the Transmit buffer (DATA in USARTn.TXDATA) with the data to be sent. The data in the transmit buffer is moved to the Shift register when the Shift register is empty and ready to send a new frame. The Shift register is loaded if it is in Idle state (no ongoing transmission) or immediately after the last Stop bit of the previous frame is transmitted. When the Shift register is loaded with data, it will transfer one complete frame.

When the entire frame in the Shift register has been shifted out and there is no new data present in the transmit buffer, the Transmit Complete Interrupt Flag (TXCIF in USARTn.STATUS) is set and the optional interrupt is generated.

TXDATA can only be written when the Data Register Empty Flag (DREIF in USARTn.STATUS) is set, indicating that the register is empty and ready for new data.

When using frames with fewer than eight bits, the Most Significant bits written to TXDATA are ignored. If 9-bit characters are used, DATA[8] in USARTn.TXDATAH has to be written before DATA[7:0] in USARTn.TXDATAL.

#### 24.3.2.3.2 Disabling the Transmitter

A disabling of the transmitter will not become effective until ongoing and pending transmissions are completed; i.e. when the Transmit Shift register and Transmit Buffer register do not contain data to be

transmitted. When the transmitter is disabled, it will no longer override the TxDn pin, and the pin direction is set as input automatically by hardware, even if it was configured as output by the user.

### 24.3.2.4 Data Reception - USART Receiver

When the receiver is enabled, the RxD pin functions as the receiver's serial input. The direction of the pin must be set as an input in the Direction register of the Port (PORTx.DIR[n]=0), which is the default pin setting.

#### 24.3.2.4.1 Receiving Frames

The receiver starts data reception when it detects a valid Start bit. Each bit that follows the Start bit will be sampled at the baud rate or XCK clock, and shifted into the Receive Shift register until the first Stop bit of a frame is received. A second Stop bit will be ignored by the receiver. When the first Stop bit is received and a complete serial frame is present in the Receive Shift register, the contents of the Shift register will be moved into the receive buffer. The receive complete interrupt flag (RXCIF in USARTn.STATUS) is set, and the optional interrupt is generated.

The receiver buffer can be read by reading RXDATA, comprising of DATA[7:0] in USARTn.RXDATAL, and DATA[8] in USARTn.RXDATAH. RXDATA should not be read unless the Receive Complete Interrupt Flag (RXCIF in USARTn.STATUS) is set. When using frames with fewer than eight bits, the unused Most Significant bits are read as zero. If 9-bit characters are used, the ninth bit (DATA[8] in USARTn.RXDATAH) must be read before the low byte (DATA[7:0] in USARTn.RXDATAL).

#### 24.3.2.4.2 Receiver Error Flags

The USART receiver has three error flags in the Receiver Data Register High Byte register (USARTn.RXDATAH):

- Frame Error (FERR)
- Buffer Overflow (BUFOVF)
- Parity Error (PERR)

The error flags are located in the receive FIFO buffer together with their corresponding frame. Due to the buffering of the error flags, the USARTn.RXDATAH must be read before the USARTn.RXDATAL, since reading the USARTn.RXDATAL changes the FIFO buffer.

#### 24.3.2.4.3 Parity Checker

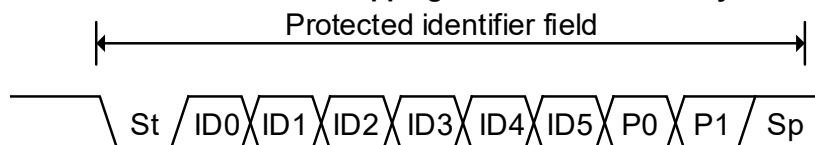
When enabled, the parity checker calculates the parity of the data bits in incoming frames and compares the result with the parity bit of the corresponding frame. If a parity error is detected, the Parity Error flag (PERR in USARTn.RXDATAH) is set.

If USART LIN mode is enabled (by writing RXMODE to '1' in USARTn.CTRLB), a parity check is only performed on the protected identifier field. A parity error is detected if one of the equations below is not true, which sets PERR in USARTn.RXDATAH.

$$P0 = ID0 \text{ XOR } ID1 \text{ XOR } ID2 \text{ XOR } ID4$$

$$P1 = \text{NOT} (ID1 \text{ XOR } ID3 \text{ XOR } ID4 \text{ XOR } ID5)$$

**Figure 24-6. Protected Identifier Field and Mapping of Identifier and Parity Bits**



#### 24.3.2.4.4 Disabling the Receiver

A disabling of the receiver will be immediate. The receiver buffer will be flushed, and data from ongoing receptions will be lost.

### 24.3.2.4.5 Flushing the Receive Buffer

If the receive buffer has to be flushed during normal operation, read the DATA location (USARTn.RXDATAH and USARTn.RXDATAL registers) until the Receive Complete Interrupt Flag (RXCIF in USARTn.RXDATAH) is cleared.

### 24.3.2.4.6 Asynchronous Data Reception

The USART includes a clock recovery and a data recovery unit for handling asynchronous data reception.

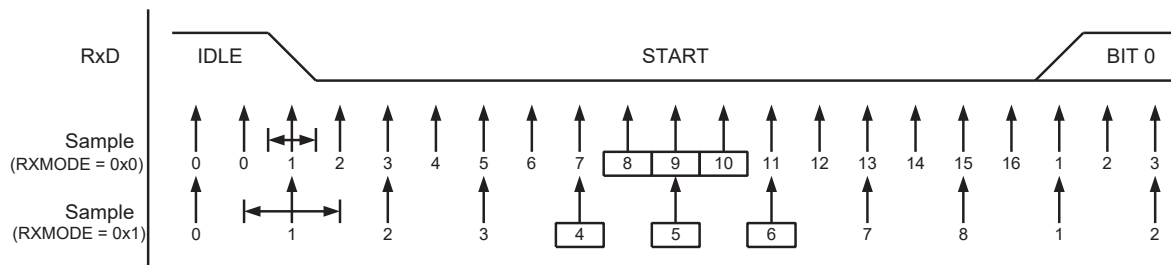
The clock recovery unit is used for synchronizing the incoming asynchronous serial frames at the RxD pin to the internally generated baud rate clock. It samples and low-pass filters each incoming bit, thereby improving the noise immunity of the receiver. The asynchronous reception operational range depends on the accuracy of the internal baud rate clock, the rate of the incoming frames, and the frame size in a number of bits.

#### Asynchronous Clock Recovery

The clock recovery unit synchronizes the internal clock to the incoming serial frames. [Figure 24-7](#) illustrates the sampling process for the Start bit of an incoming frame:

- In Normal mode, the sample rate is 16 times the baud rate.
- In Double-Speed mode, the sample rate is eight times the baud rate.
- The horizontal arrows illustrate the synchronization variation due to the sampling process. Note that in Double-Speed mode, the variation is larger.
- Samples denoted as zero are sampled with the RxD line idle (i.e., when there is no communication activity).

**Figure 24-7. Start Bit Sampling**



When the clock recovery logic detects a high-to-low (i.e., idle-to-start) transition on the RxD line, the Start bit detection sequence is initiated. Sample 1 denotes the first zero-sample, as shown in the figure. The clock recovery logic then uses three subsequent samples (samples 8, 9, and 10 in Normal mode, samples 4, 5, and 6 in Double-Speed mode) to decide if a valid Start bit is received:

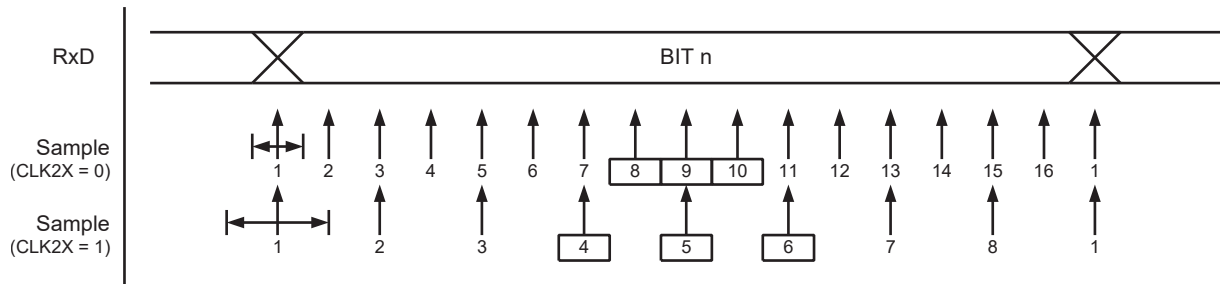
- If two or three samples have a low level, the Start bit is accepted. The clock recovery unit is synchronized, and the data recovery can begin.
- If two or three samples have a high level, the Start bit is rejected as a noise spike, and the receiver looks for the next high-to-low transition.

The process is repeated for each Start bit.

#### Asynchronous Data Recovery

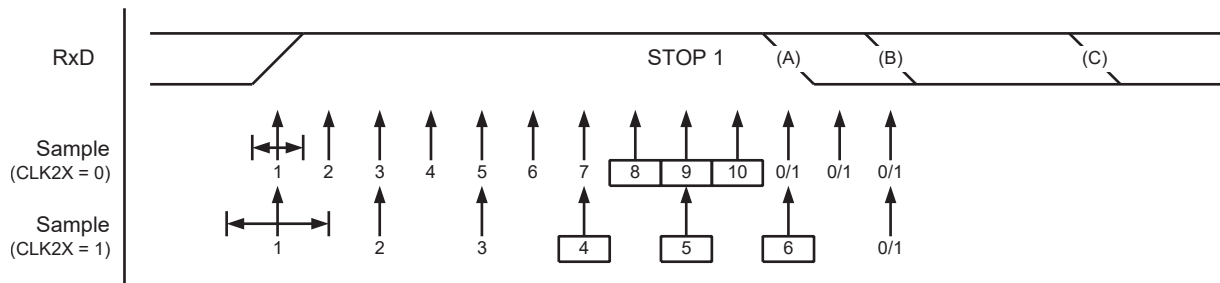
The data recovery unit uses sixteen samples in Normal mode and eight samples in Double-Speed mode for each bit. The following figure shows the sampling process of data and parity bits.

Figure 24-8. Sampling of Data and Parity Bits



As for Start bit detection, an identical majority voting technique is used on the three center samples for deciding of the logic level of the received bit. The process is repeated for each bit until a complete frame is received. It includes the first Stop bit but excludes additional ones. If the sampled Stop bit is a '0' value, the Frame Error (FERR in USARTn.RXDATAH) flag will be set. The next figure shows the sampling of the Stop bit in relation to the earliest possible beginning of the next frame's Start bit.

Figure 24-9. Stop Bit and Next Start Bit Sampling



A new high-to-low transition indicating the Start bit of a new frame can come right after the last of the bits used for majority voting. For Normal-Speed mode, the first low-level sample can be at the point marked (A) in Stop Bit Sampling and Next Start Bit Sampling. For Double-Speed mode, the first low level must be delayed to point (B). Point (C) marks a Stop bit of full length at the nominal baud rate. The early Start bit detection influences the operational range of the receiver.

24.3.2.4.7 Asynchronous Operational Range

The operational range of the receiver is dependent on the mismatch between the received bit rate and the internally generated baud rate. If an external transmitter is sending using bit rates that are too fast or too slow, or if the internally generated baud rate of the receiver does not match the external source's base frequency, the receiver will not be able to synchronize the frames to the Start bit.

The following equations can be used to calculate the ratio of the incoming data rate and internal receiver baud rate.

$R_{SLOW} = \frac{16(D + 1)}{16(D + 1) + 6}$	$R_{FAST} = \frac{16(D + 2)}{16(D + 1) + 8}$
--	--

**Table 24-5. Formula Nomenclature**

Symbol	Meaning
D	Sum of character size and parity size (D = 5 to 10 bit)
$R_{slow}$	The ratio of the slowest incoming data rate that can be accepted in relation to the receiver baud rate
$R_{fast}$	The ratio of the fastest incoming data rate that can be accepted in relation to the receiver baud rate

The following tables list the maximum receiver baud rate error that can be tolerated. Normal Speed mode has higher toleration of baud rate variations.

**Table 24-6. Recommended Maximum Receiver Baud Rate Error for Normal Speed Mode (CLK2X = 0)**

D #(Data + Parity Bit)	$R_{slow}$ [%]	$R_{fast}$ [%]	Maximum Total Error [%]	Receiver Max. Receiver Error [%]
5	93.20	106.67	+6.67/-6.80	±3.0
6	94.12	105.79	+5.79/-5.88	±2.5
7	94.81	105.11	+5.11/-5.19	±2.0
8	95.36	104.58	+4.58/-4.54	±2.0
9	95.81	104.14	+4.14/-4.19	±1.5
10	96.17	103.78	+3.78/-3.83	±1.5

**Table 24-7. Recommended Maximum Receiver Baud Rate Error for Double Speed Mode (CLK2X = 1)**

D #(Data + Parity Bit)	$R_{slow}$ [%]	$R_{fast}$ [%]	Maximum Total Error [%]	Receiver Max. Receiver Error [%]
5	94.12	105.66	+5.66/-5.88	±2.5
6	94.92	104.92	+4.92/-5.08	±2.0
7	95.52	104.35	+4.35/-4.48	±1.5
8	96.00	103.90	+3.90/-4.00	±1.5
9	96.39	103.53	+3.53/-3.61	±1.5
10	96.70	103.23	+3.23/-3.30	±1.0

The recommendations of the maximum receiver baud rate error were made under the assumption that the receiver and transmitter equally divide the maximum total error.

### 24.3.2.5 USART in Master SPI mode

Using the USART in Master SPI mode requires the transmitter to be enabled. The receiver can optionally be enabled to serve as the serial input. The XCK pin will be used as the transfer clock.

As for the USART, a data transfer is initiated by writing to the USARTn.DATA register. This is the case for both sending and receiving data since the transmitter controls the transfer clock. The data written to

USARTn.DATA are moved from the transmit buffer to the Shift register when the Shift register is ready to send a new frame.

The transmitter and receiver interrupt flags and corresponding USART interrupts used in Master SPI mode are identical in function to their use in normal USART operation. The receiver error status flags are not in use and are always read as zero.

Disabling of the USART transmitter or receiver in Master SPI mode is identical to their disabling in normal USART operation.

### Related Links

[24.5.9 CTRLC](#)

#### 24.3.2.5.1 USART SPI vs. SPI

The USART in Master SPI mode is fully compatible with the stand-alone SPI module in that:

- Timing diagrams are the same
- UCPHA bit functionality is identical to that of the SPI CPHA bit
- UDORD bit functionality is identical to that of the SPI DORD bit

When the USART is set in Master SPI mode, configuration and use are in some cases different from those of the stand-alone SPI module. In addition, the following difference exists:

- The USART in Master SPI mode does not include the SPI Write Collision feature

The USART in Master SPI mode does not include the SPI Double-Speed mode feature, but this can be achieved by configuring the Baud Rate Generator accordingly:

- Interrupt timing is not compatible
- Pin control differs due to the master-only operation of the USART in SPI Master mode

A comparison of the USART in Master SPI mode and the SPI pins is shown in [Table 24-8](#).

**Table 24-8. Comparison of USART in Master SPI Mode and SPI Pins**

USART	SPI	Comment
TxD	MOSI	Master out only
RxD	MISO	Master in only
XCK	SCK	Functionally identical
-	SS	Not supported by USART in Master SPI mode

### Related Links

[24.5.9 CTRLC](#)

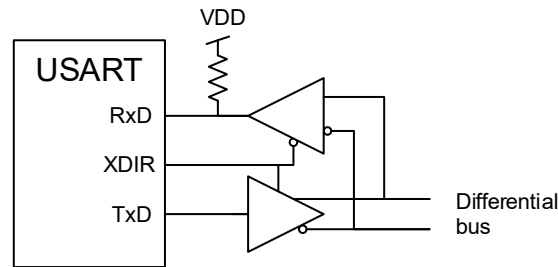
#### 24.3.2.6 RS-485 Mode of Operation

The RS-485 feature enables the support of external components to comply with the RS-485 standard.

Either an external line driver is supported as shown in the figure below (RS485=0x1 in USARTn.CTRLA), or control of the transmitter driving the TxD pin is provided (RS485=0x2).

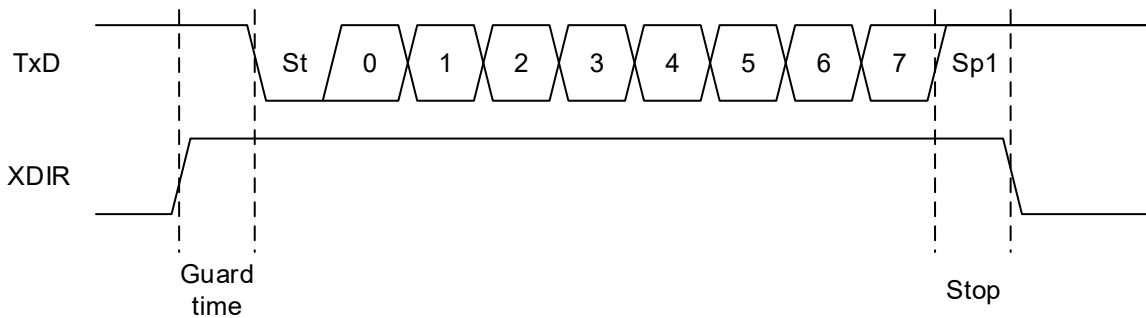
While operating in RS-485 mode, the Transmit Direction pin (XDIR) is driven high when the transmitter is active.

**Figure 24-10. RS-485 Bus Connection**



The XDIR pin goes high one baud clock cycle in advance of data being shifted out, to allow some guard time to enable the external line driver. The XDIR pin will remain high for the complete frame including Stop bit(s).

**Figure 24-11. XDIR Drive Timing**



### Related Links

[24.2.1 Signal Description](#)

#### 24.3.2.7 Start Frame Detection

The start frame detection is supported in UART mode only. The UART start frame detector is limited to Standby Sleep mode only and can wake up the system when a Start bit is detected.

When a high-to-low transition is detected on RxDn, the oscillator is powered up and the UART clock is enabled. After start-up, the rest of the data frame can be received, provided that the baud rate is slow enough in relation to the oscillator start-up time. Start-up time of the oscillators varies with supply voltage and temperature. For details on oscillator start-up time characteristics, refer to the Electrical Characteristics.

If a false Start bit is detected and if the system has not been woken up by another source, the clock will automatically be turned OFF and the UART waits for the next transition.

The UART start frame detection works in Asynchronous mode only. It is enabled by writing the Start Frame Detection bit (SFDEN) in USARTn.CTLB. If the Start bit is detected while the device is in Standby Sleep mode, the UART Start Interrupt Flag (RXSIF) bit is set.

In Active, Idle, and Power-Down Sleep modes, the asynchronous detection is automatically disabled.

The UART receive complete flag and UART start interrupt flag share the same interrupt line, but each has its dedicated interrupt settings. [Table 24-9](#) shows the USART start frame detection modes, depending on interrupt setting.

**Table 24-9. USART Start Frame Detection Modes**

SFDEN	RXSIF Interrupt	RXCIF Interrupt	Comment
0	x	x	Standard mode.
1	Disabled	Disabled	Only the oscillator is powered during the frame reception. If the interrupts are disabled and buffer overflow is ignored, all incoming frames will be lost.
1 <sup>(1)</sup>	Disabled	Enabled	System/all clocks are awakened on Receive Complete interrupt.
1 <sup>(1)</sup>	Enabled	x	System/all clocks are awakened on UART Start Detection.

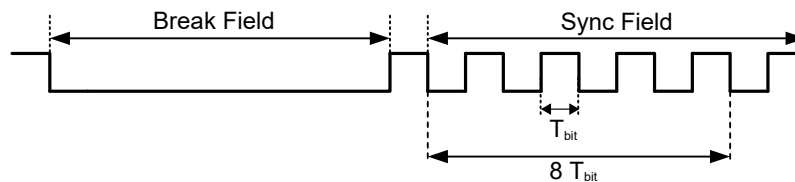
**Note:**

1. The SLEEP instruction will not shut down the oscillator if there is ongoing communication.

### 24.3.2.8 Break Character Detection and Auto-Baud

When USART receive mode is set to LINAUTO mode (RXMODE in USARTn.CTRLB), it follows the LIN format. All LIN frames start with a break field followed by a sync field. The USART uses a break detection threshold of greater than 11 nominal bit times at the configured baud rate. At any time, if more than 11 consecutive dominant bits are detected on the bus, the USART detects a break field. When a break field has been detected, the USART expects the sync field character to be 0x55. This field is used to update the actual baud rate in order to stay synchronized. If the received sync character is not 0x55, then the Inconsistent Sync Field Error flag (ISFIF in USARTn.STATUS) is set and the baud rate is unchanged.

**Figure 24-12. LIN Break and Sync Fields**



After a break field is detected and the Start bit of the sync field is detected, a counter is started. The counter is then incremented for the next eight  $T_{bit}$  of the sync field. At the end of these 8-bit times, the counter is stopped. At this moment, the ten Most Significant bits of the counter (value divided by 64) gives the new clock divider and the six Least Significant bits of this value (the remainder) gives the new fractional part. When the sync field has been received and all bits are found valid, the clock divider and the fractional part are updated in the Baud Rate Generator register (USARTn.BAUD). After the break and sync fields,  $n$  characters of data can be received.

When the USART receive mode is set to GENAUTO mode, a generic Auto-baud mode is enabled. In this mode, there are no checks of the sync character to equal 0x55. After detection of a break field, the USART expects the next character to be a sync field, counting eight low and high bit times. If the measured sync field results in a valid BAUD value (0x0064-0xffff), the BAUD register is updated. Setting the Wait for Break bit (WFB in USARTn.STATUS) before receiving the next break character, the next negative plus positive edge of RxD line is detected as a break. This makes it possible to set an arbitrary new baud rate without knowing the current baud rate.

### 24.3.2.9 One-Wire Mode

In this mode, the TxD pin is connected to the RxD pin internally. If the receiver is enabled when transmitting it will receive what the transmitter is sending. This can be used to check that no one else is trying to transmit since received data will not be the same as the transmitted data.



### 24.3.2.10 Multiprocessor Communication Mode

The Multiprocessor Communication mode (MCPM) effectively reduces the number of incoming frames that have to be handled by the receiver in a system with multiple microcontrollers communicating via the same serial bus. This mode is enabled by writing a '1' to the MCPM bit in the Control B register (USARTn.CTRLB). In this mode, a dedicated bit in the frames is used to indicate whether the frame is an address or data frame type.

If the receiver is set up to receive frames that contain five to eight data bits, the first Stop bit is used to indicate the frame type. If the receiver is set up for frames with nine data bits, the ninth bit is used to indicate frame type. When the frame type bit is one, the frame contains an address. When the frame type bit is zero, the frame is a data frame. If 5- to 8-bit character frames are used, the transmitter must be set to use two Stop bits, since the first Stop bit is used for indicating the frame type.

If a particular slave MCU has been addressed, it will receive the following data frames as usual, while the other slave MCUs will ignore the frames until another address frame is received.

#### 24.3.2.10.1 Using Multiprocessor Communication Mode

The following procedure should be used to exchange data in Multiprocessor Communication mode (MPCM):

1. All slave MCUs are in Multiprocessor Communication mode.
2. The master MCU sends an address frame, and all slaves receive and read this frame.
3. Each slave MCU determines if it has been selected.
4. The addressed MCU will disable MPCM and receive all data frames. The other slave MCUs will ignore the data frames.
5. When the addressed MCU has received the last data frame, it must enable MPCM again and wait for a new address frame from the master.

The process then repeats from step 2.

Using any of the 5- to 8-bit character frame formats is impractical, as the receiver must change between using  $n$  and  $n+1$  character frame formats. This makes full-duplex operation difficult since the transmitter and receiver must use the same character size setting.

### 24.3.2.11 IRCOM Mode of Operation

The IRCOM mode enables IrDA<sup>®</sup> 1.4 compliant modulation and demodulation for baud rates up to 115.2 kbps. When IRCOM mode is enabled, Double-Speed mode cannot be used for the USART.

#### 24.3.2.11.1 Overview

A USART can be configured in infrared communication mode (IRCOM) that is IrDA compatible with baud rates up to 115.2 kbps. When enabled, the IRCOM mode enables infrared pulse encoding/decoding for the USART.

A USART is set in IRCOM mode by writing 0x2 to the CMODE bits in USARTn.CTRLA. The data on the TX/RX pins is the inverted value of the transmitted/received infrared pulse. It is also possible to select an event channel from the Event System as an input for the IRCOM receiver. This will disable the RX input from the USART pin.

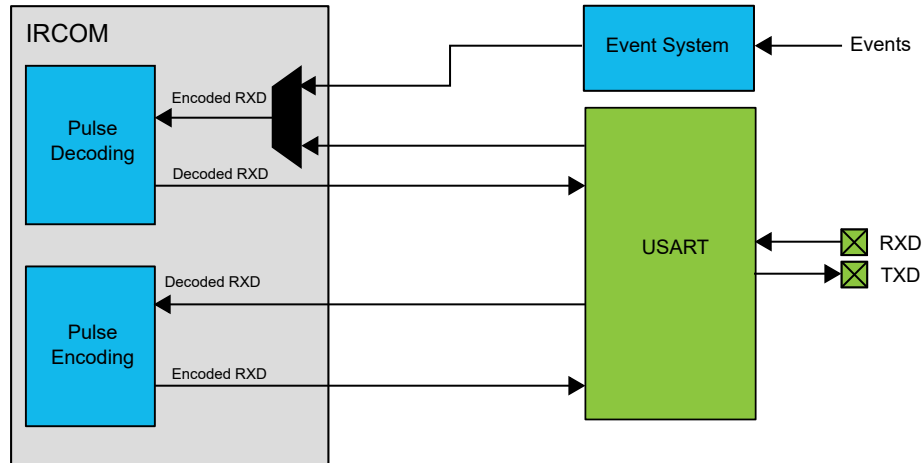
For transmission, three pulse modulation schemes are available:

- 3/16 of the baud rate period
- Fixed programmable pulse time based on the peripheral clock frequency
- Pulse modulation disabled

For the reception, a fixed programmable minimum high-level pulse-width for the pulse to be decoded as a logical '0' is used. Shorter pulses will then be discarded, and the bit will be decoded to logical '1' as if no pulse was received.

### 24.3.2.11.2 Block Diagram

**Figure 24-13. Block Diagram**



### 24.3.2.11.3 IRCOM and Event System

The Event System can be used as the receiver input. This enables the IRCOM or USART input from the I/O pins or sources other than the corresponding RX pin. If the Event System input is enabled, input from the USART's RX pin is automatically disabled.

#### Related Links

[14. EVSYS - Event System](#)

### 24.3.3 Events

The USART can accept the following input events:

- IREI - IrDA Event Input

The event is enabled by writing a '1' to the IrDA Event Input bit (IREI) in the Event Control register (USART.EVCTRL).

#### Related Links

[14. EVSYS - Event System](#)

[24.5.12 EVCTRL](#)

### 24.3.4 Interrupts

**Table 24-10. Available Interrupt Vectors and Sources**

Offset	Name	Vector Description	Conditions
0x00	RXC	Receive Complete Interrupt	<ul style="list-style-type: none"> <li>• There are unread data in the receive buffer (RXCIE)</li> <li>• Receive of Start-of-Frame detected (RXSIE)</li> </ul>

Offset	Name	Vector Description	Conditions
			<ul style="list-style-type: none"> <li>Auto-Baud Error/ISFIF flag set (ABEIE)</li> </ul>
0x02	DRE	Data Register Empty Interrupt	The transmit buffer is empty/ready to receive new data (DREIE).
0x04	TXC	Transmit Complete Interrupt	The entire frame in the Transmit Shift register has been shifted out and there are no new data in the transmit buffer (TXCIE).

When an interrupt condition occurs, the corresponding interrupt flag is set in the STATUS register (USART.STATUS).

An interrupt source is enabled or disabled by writing to the corresponding bit in the Control A register (USART.CTRLA).

An interrupt request is generated when the corresponding interrupt source is enabled and the interrupt flag is set. The interrupt request remains active until the interrupt flag is cleared. See the USART.STATUS register for details on how to clear interrupt flags.

### Related Links

[13. CPUINT - CPU Interrupt Controller](#)

[24.5.5 STATUS](#)

[24.5.6 CTRLA](#)

### 24.3.5 Configuration Change Protection

Not applicable.

### 24.4 Register Summary - USART

Offset	Name	Bit Pos.								
0x00	<a href="#">RXDATAL</a>	7:0	DATA[7:0]							
0x01	<a href="#">RXDATAH</a>	7:0	RXCIF	BUFOVF				FERR	PERR	DATA[8]
0x02	<a href="#">TXDATAL</a>	7:0	DATA[7:0]							
0x03	<a href="#">TXDATAH</a>	7:0								DATA[8]
0x04	<a href="#">STATUS</a>	7:0	RXCIF	TXCIF	DREIF	RXSIF	ISFIF		BDF	WFB
0x05	<a href="#">CTRLA</a>	7:0	RXCIE	TXCIE	DREIE	RXSIE	LBME	ABEIE	RS485[1:0]	
0x06	<a href="#">CTRLB</a>	7:0	RXEN	TXEN		SFDEN	ODME	RXMODE[1:0]		MPCM
0x07	<a href="#">CTRLC</a>	7:0	CMODE[1:0]		PMODE[1:0]		SBMODE	CHSIZE[2:0]		
0x07	<a href="#">CTRLC</a>	7:0	CMODE[1:0]					UDORD	UCPHA	
0x08	<a href="#">BAUD</a>	7:0	BAUD[7:0]							
		15:8	BAUD[15:8]							
0x0A	Reserved									
0x0B	<a href="#">DBGCTRL</a>	7:0								DBGRUN
0x0C	<a href="#">EVCTRL</a>	7:0								IREI
0x0D	<a href="#">TXPLCTRL</a>	7:0	TXPL[7:0]							
0x0E	<a href="#">RXPLCTRL</a>	7:0		RXPL[6:0]						

### 24.5 Register Description

### 24.5.1 Receiver Data Register Low Byte

**Name:** RXDATAL  
**Offset:** 0x00  
**Reset:** 0x00  
**Property:** R

Reading the USARTn.RXDATAL Register will return the contents of the Receive Data Buffer register (RXB).

The receive buffer consists of a two-level FIFO. The FIFO and the corresponding flags in the high byte of RXDATA will change state whenever the receive buffer is accessed (read). If CHSIZE in USARTn.CTRLA is set to 9BIT Low byte first, read USARTn.RXDATAL before USARTn.RXDATAH. Otherwise, always read USARTn.RXDATAH before USARTn.RXDATAL in order to get the correct flags.

Bit	7	6	5	4	3	2	1	0
	DATA[7:0]							
Access	R	R	R	R	R	R	R	R
Reset	0	0	0	0	0	0	0	0

**Bits 7:0 – DATA[7:0]** Receiver Data Register

### 24.5.2 Receiver Data Register High Byte

**Name:** RXDATAH  
**Offset:** 0x01  
**Reset:** 0x00  
**Property:** -

Reading the USARTn.RXDATAH register location will return the contents of the ninth DATA bit plus Status bits.

The receive buffer consists of a two-level FIFO. The FIFO and the corresponding flags in the high byte of USARTn.RXDATAH will change state whenever the receive buffer is accessed (read). If CHSIZE in USARTn.CTRLA is set to 9BIT Low byte first, read USARTn.RXDATAL before USARTn.RXDATAH. Otherwise, always read USARTn.RXDATAH before USARTn.RXDATAL in order to get the correct flags.

Bit	7	6	5	4	3	2	1	0
	RXCIF	BUFOVF				FERR	PERR	DATA[8]
Access	R	R				R	R	R
Reset	0	0				0	0	0

#### Bit 7 – RXCIF USART Receive Complete Interrupt Flag

This flag is set when there is unread data in the receive buffer and cleared when the receive buffer is empty (i.e. does not contain any unread data). When the receiver is disabled, the receive buffer will be flushed and consequently, the RXCIF will become '0'.

#### Bit 6 – BUFOVF Buffer Overflow

The BUFOVF flag indicates data loss due to a receiver buffer full condition. This flag is set if a Buffer Overflow condition is detected. A Buffer Overflow occurs when the receive buffer is full (two characters), it is a new character waiting in the Receive Shift register, and a new Start bit is detected. This flag is valid until the receive buffer (USARTn.RXDATAL) is read.

This flag is not used in Master SPI mode of operation.

#### Bit 2 – FERR Frame Error

The FERR flag indicates the state of the first Stop bit of the next readable frame stored in the receive buffer. The bit is set if the received character had a Frame Error (i.e. when the first Stop bit was '0' and cleared when the Stop bit of the received data is '1'). This bit is valid until the receive buffer (USARTn.RXDATAL) is read. The FERR is not affected by the SBMODE bit in USARTn.CTRLA since the receiver ignores all, except for the first Stop bit.

This flag is not used in Master SPI mode of operation.

#### Bit 1 – PERR Parity Error

If parity checking is enabled and the next character in the receive buffer has a Parity Error this flag is set. If Parity Check is not enabled the PERR will always be read as '0'. This bit is valid until the receive buffer (USARTn.RXDATAL) is read. For details on parity calculation refer to [24.3.2.2.1 Parity](#). If USART is set to LINAUTO mode, this bit will be a Parity Check of the protected identifier field and will be valid when DATA[8] in USARTn.RXDATAH reads low.

This flag is not used in Master SPI mode of operation.

### **Bit 0 – DATA[8]** Receiver Data Register

When USART receiver is set to LINAUTO mode, this bit indicates if the received data is within the response space of a LIN frame. If the received data is the protected identifier field, this bit will be read as '0'. Otherwise, the bit will be read as '1'. For Receiver mode other than LINAUTO mode, DATA[8] holds the ninth data bit in the received character when operating with serial frames with nine data bits.

### 24.5.3 Transmit Data Register Low Byte

**Name:** TXDATAL  
**Offset:** 0x02  
**Reset:** 0x00  
**Property:** R/W

The Transmit Data Buffer (TXB) register will be the destination for data written to the USARTn.TXDATAL register location.

For 5-, 6-, or 7-bit characters the upper unused bits will be ignored by the transmitter and set to '0' by the receiver.

The transmit buffer can only be written when the DREIF flag in the USARTn.STATUS register is set. Data written to DATA when the DREIF flag is not set will be ignored by the USART transmitter. When data is written to the transmit buffer, and the transmitter is enabled, the transmitter will load the data into the Transmit Shift register when the Shift register is empty. The data is then transmitted on the TxD pin.

Bit	7	6	5	4	3	2	1	0
	DATA[7:0]							
Access	R/W	R/W	R/W	R/W	R/W	R/W	R/W	R/W
Reset	0	0	0	0	0	0	0	0

**Bits 7:0 – DATA[7:0]** Transmit Data Register



### 24.5.4 Transmit Data Register High Byte

**Name:** TXDATAH  
**Offset:** 0x03  
**Reset:** 0x00  
**Property:** -

USARTn.TXDATAH holds the ninth data bit in the character to be transmitted when operating with serial frames with nine data bits. When used this bit must be written before writing to USARTn.TXDATAL except if CHSIZE in USARTn.CTRLA is set to 9BIT Low byte first where USARTn.TXDATAL should be written first.

This bit is unused in Master SPI mode of operation.

Bit	7	6	5	4	3	2	1	0
								DATA[8]
Access								W
Reset								0

#### Bit 0 – DATA[8] Transmit Data Register

This bit is used when CHSIZE=9BIT in USARTn.CTRLA.

### 24.5.5 USART Status Register

**Name:** STATUS  
**Offset:** 0x04  
**Reset:** 0x00  
**Property:** -

Bit	7	6	5	4	3	2	1	0
	RXCIF	TXCIF	DREIF	RXSIF	ISFIF		BDF	WFB
Access	R	R/W	R	R/W	R/W		R/W	R/W
Reset	0	0	0	0	0		0	0

#### Bit 7 – RXCIF USART Receive Complete Interrupt Flag

This flag is set to '1' when there is unread data in the receive buffer and cleared when the receive buffer is empty (i.e. does not contain any unread data). When the receiver is disabled, the receive buffer will be flushed and consequently, the RXCIF will become '0'.

When interrupt-driven data reception is used, the receive complete interrupt routine must read the received data from RXDATA in order to clear the RXCIF. If not, a new interrupt will occur directly after the return from the current interrupt.

#### Bit 6 – TXCIF USART Transmit Complete Interrupt Flag

This flag is set when the entire frame in the Transmit Shift register has been shifted out and there are no new data in the transmit buffer (TXDATA).

This flag is automatically cleared when the transmit complete interrupt vector is executed. The flag can also be cleared by writing a '1' to its bit location.

#### Bit 5 – DREIF USART Data Register Empty Flag

The DREIF indicates if the transmit buffer (TXDATA) is ready to receive new data. The flag is set to '1' when the transmit buffer is empty and is '0' when the transmit buffer contains data to be transmitted that has not yet been moved into the Shift register. DREIF is set after a Reset to indicate that the transmitter is ready. Always write this bit to '0' when writing the STATUS register.

DREIF is cleared to '0' by writing TXDATA. When interrupt-driven data transmission is used, the Data Register Empty interrupt routine must either write new data to TXDATA in order to clear DREIF or disable the Data Register Empty interrupt. If not, a new interrupt will occur directly after the return from the current interrupt.

#### Bit 4 – RXSIF USART Receive Start Interrupt Flag

The RXSIF flag indicates a valid Start condition on RxD line. The flag is set when the system is in standby modes and a high (IDLE) to low (START) valid transition is detected on the RxD line. If the start detection is not enabled, the RXSIF will always be read as '0'. This flag can only be cleared by writing a '1' to its bit location. This flag is not used in the Master SPI mode operation.

#### Bit 3 – ISFIF Inconsistent Sync Field Interrupt Flag

This bit is set when the auto-baud is enabled and the sync field bit time is too fast or too slow to give a valid baud setting. It will also be set when USART is set to LINAUTO mode and the SYNC character differ from data value 0x55.

Writing a '1' to this bit will clear the flag and bring the USART back to Idle state.

**Bit 1 – BDF** Break Detected Flag

This bit is intended for USART configured to LINAUTO receive mode. The break detector has a fixed threshold of 11 bits low for a Break to be detected. The BDF bit is set after a valid BREAK and SYNC character is detected. The bit is automatically cleared when next data is received. The bit will behave identically when USART is set to GENAUTO mode. In NORMAL or CLK2X receive mode, the BDF bit is unused.

This bit is cleared by writing a '1' to it.

**Bit 0 – WFB** Wait For Break

Writing this bit to '1' will register the next low and high transition on RxD line as a Break character. This can be used to wait for a Break character of arbitrary width. Combined with USART set to GENAUTO mode, this allows the user to set any BAUD rate through BREAK and SYNC as long as it falls within the valid range of the USARTn.BAUD register. This bit will always read '0'.

### 24.5.6 Control A

**Name:** CTRLA  
**Offset:** 0x05  
**Reset:** 0x00  
**Property:** -

Bit	7	6	5	4	3	2	1	0
	RXCIE	TXCIE	DREIE	RXSIE	LBME	ABEIE	RS485[1:0]	
Access	R/W	R/W	R/W	R/W	R/W	R/W	R/W	R/W
Reset	0	0	0	0	0	0	0	0

#### Bit 7 – RXCIE Receive Complete Interrupt Enable

The bit enables the Receive Complete Interrupt (interrupt vector RXC). The enabled interrupt will be triggered when RXCIF in the USARTn.STATUS register is set.

#### Bit 6 – TXCIE Transmit Complete Interrupt Enable

This bit enables the Transmit Complete Interrupt (interrupt vector TXC). The enabled interrupt will be triggered when the TXCIF in the USARTn.STATUS register is set.

#### Bit 5 – DREIE Data Register Empty Interrupt Enable

This bit enables the Data Register Empty Interrupt (interrupt vector DRE). The enabled interrupt will be triggered when the DREIF in the USART.STATUS register is set.

#### Bit 4 – RXSIE Receiver Start Frame Interrupt Enable

Writing a '1' to this bit enables the Start Frame Detector to generate an interrupt on interrupt vector RXC when a start-of-frame condition is detected.

#### Bit 3 – LBME Loop-back Mode Enable

Writing this bit to '1' enables an internal connection between the TxD and RxD pin.

#### Bit 2 – ABEIE Auto-baud Error Interrupt Enable

Writing this bit to '1' enables the auto-baud error interrupt on interrupt vector RXC. The enabled interrupt will trigger for conditions where the ISFIF flag is set.

#### Bits 1:0 – RS485[1:0] RS-485 Mode

These bits enable the RS-485 and select the operation mode.

Value	Name	Description
0x0	OFF	Disabled.
0x1	EXT	Enables RS-485 mode with control of an external line driver through a dedicated Transmit Enable (TE) pin.
0x2	INT	Enables RS-485 mode with control of the internal USART transmitter.
0x3	-	Reserved.

### 24.5.7 Control B

**Name:** CTRLB  
**Offset:** 0x06  
**Reset:** 0x00  
**Property:** -

Bit	7	6	5	4	3	2	1	0
	RXEN	TXEN		SFDEN	ODME	RXMODE[1:0]		MPCM
Access	R/W	R/W		R/W	R/W	R/W	R/W	R/W
Reset	0	0		0	0	0	0	0

#### Bit 7 – RXEN Receiver Enable

Writing this bit to '1' enables the USART receiver. The receiver will override normal port operation for the RxD pin when enabled. Disabling the receiver will flush the receive buffer invalidating the FERR, BUFOVF, and PERR flags. In GENAUTO and LINAUTO mode, disabling the receiver will reset the auto-baud detection logic.

#### Bit 6 – TXEN Transmitter Enable

Writing this bit to '1' enables the USART transmitter. The transmitter will override normal port operation for the TxD pin when enabled. Disabling the transmitter (writing TXEN to '0') will not become effective until ongoing and pending transmissions are completed (i.e. when the Transmit Shift register and Transmit Buffer register does not contain data to be transmitted). When the transmitter is disabled, it will no longer override the TxDn pin, and the pin direction is set as input automatically by hardware, even if it was configured as output by the user.

#### Bit 4 – SFDEN Start Frame Detection Enable

Writing this bit to '1' enables the USART Start Frame Detection mode. The Start Frame detector is able to wake up the system from Idle or Standby Sleep modes when a high (IDLE) to low (START) transition is detected on the RxD line.

#### Bit 3 – ODME Open Drain Mode Enable

Writing this bit to '1' makes the TxD pin to have open-drain functionality. A pull-up resistor is needed to prevent the line from floating when a logic '1' is output to the TxD pin.

#### Bits 2:1 – RXMODE[1:0] Receiver Mode

In CLK2X mode, the divisor of the baud rate divider will be reduced from 16 to 8 effectively doubling the transfer rate for asynchronous communication modes. For synchronous operation, the CLK2X mode has no effect and RXMODE should always be written to '0'. RXMODE must be '0' when the USART Communication mode is configured to IRCOM. Setting RXMODE to GENAUTO enables generic auto-baud where the SYNC character is valid when eight low and high bits have been registered. In this mode, any SYNC character that gives a valid BAUD rate will be accepted. In LINAUTO mode the SYNC character is constrained and found valid if every two bits falls within  $32 \pm 6$  baud samples of the internal baud rate and match data value 0x55. The GENAUTO and LINAUTO mode is only supported for USART operated in Asynchronous Slave mode.

Value	Name	Description
0x0	NORMAL	Normal USART mode, Standard Transmission Speed
0x1	CLK2X	Normal USART mode, Double Transmission Speed

Value	Name	Description
0x2	GENAUTO	Generic Auto-baud mode
0x3	LINAUTO	LIN Constrained Auto-baud mode

### Bit 0 – MPCM Multi-Processor Communication Mode

Writing a '1' to this bit enables the Multi-Processor Communication mode: the USART receiver ignores all the incoming frames that do not contain address information. The transmitter is unaffected by the MPCM setting. For more detailed information see [24.3.2.10 Multiprocessor Communication Mode](#).

### 24.5.8 Control C - Async Mode

**Name:** CTRLC  
**Offset:** 0x07  
**Reset:** 0x03  
**Property:** -

This register description is valid for all modes except Master SPI mode. When the USART Communication mode bits (CMODE) in this register are written to 'MSPI', see [Control C - Master SPI Mode](#) for the correct description.

Bit	7	6	5	4	3	2	1	0
	CMODE[1:0]		PMODE[1:0]		SBMODE	CHSIZE[2:0]		
Access	R/W	R/W	R/W	R/W	R/W	R/W	R/W	R/W
Reset	0	0	0	0	0	0	1	1

#### Bits 7:6 – CMODE[1:0] USART Communication Mode

Writing these bits select the Communication mode of the USART.

Writing a 0x3 to these bits alters the available bit fields in this register, see [Control C - Master SPI Mode](#).

Value	Name	Description
0x0	ASYNCHRONOUS	Asynchronous USART
0x1	SYNCHRONOUS	Synchronous USART
0x2	IRCOM	Infrared Communication
0x3	MSPI	Master SPI

#### Bits 5:4 – PMODE[1:0] Parity Mode

Writing these bits enable and select the type of parity generation.

When enabled, the transmitter will automatically generate and send the parity of the transmitted data bits within each frame. The receiver will generate a parity value for the incoming data, compare it to the PMODE setting, and set the Parity Error flag (PERR) in the STATUS register (USARTn.STATUS) if a mismatch is detected.

Value	Name	Description
0x0	DISABLED	Disabled
0x1	-	Reserved
0x2	EVEN	Enabled, Even Parity
0x3	ODD	Enabled, Odd Parity

#### Bit 3 – SBMODE Stop Bit Mode

Writing this bit selects the number of Stop bits to be inserted by the transmitter.

The receiver ignores this setting.

Value	Description
0	1 Stop bit
1	2 Stop bits

### Bits 2:0 – CHSIZE[2:0] Character Size

Writing these bits select the number of data bits in a frame. The receiver and transmitter use the same setting. For 9BIT character size, the order of which byte to read or write first, low or high byte of RXDATA or TXDATA is selectable.

Value	Name	Description
0x0	5BIT	5-bit
0x1	6BIT	6-bit
0x2	7BIT	7-bit
0x3	8BIT	8-bit
0x4	-	Reserved
0x5	-	Reserved
0x6	9BITL	9-bit (Low byte first)
0x7	9BITH	9-bit (High byte first)



### 24.5.9 Control C - Master SPI Mode

**Name:** CTRLC  
**Offset:** 0x07  
**Reset:** 0x00  
**Property:** -

This register description is valid only when the USART is in Master SPI mode (CMODE written to MSPI). For other CMODE values, see [Control C - Async Mode](#).

See [24.3.2.5 USART in Master SPI mode](#) for a full description of the Master SPI mode operation.

Bit	7	6	5	4	3	2	1	0
	CMODE[1:0]					UDORD	UCPHA	
Access	R/W	R/W				R/W	R/W	
Reset	0	0				0	0	

#### Bits 7:6 – CMODE[1:0] USART Communication Mode

Writing these bits select the communication mode of the USART.

Writing a value different than 0x3 to these bits alters the available bit fields in this register, see [Control C - Async Mode](#).

Value	Name	Description
0x0	ASYNCHRONOUS	Asynchronous USART
0x1	SYNCHRONOUS	Synchronous USART
0x2	IRCOM	Infrared Communication
0x3	MSPI	Master SPI

#### Bit 2 – UDORD Data Order

Writing this bit selects the frame format.

The receiver and transmitter use the same setting. Changing the setting of UDORD will corrupt all ongoing communication for both the receiver and the transmitter.

Value	Description
0	MSB of the data word is transmitted first
1	LSB of the data word is transmitted first

#### Bit 1 – UCPHA Clock Phase

The UCPHA bit setting determines if data is sampled on the leading (first) edge or trailing (last) edge of XCKn. Refer to the [24.3.2.1.5 Master SPI Mode Clock Generation](#) for details.

### 24.5.10 Baud Register

**Name:** BAUD  
**Offset:** 0x08  
**Reset:** 0x00  
**Property:** -

The USARTn.BAUDL and USARTn.BAUDH register pair represents the 16-bit value, USARTn.BAUD. The low byte [7:0] (suffix L) is accessible at the original offset. The high byte [15:8] (suffix H) can be accessed at offset + 0x01.

Ongoing transmissions of the transmitter and receiver will be corrupted if the baud rate is changed. Writing this register will trigger an immediate update of the baud rate prescaler. For more information on how to set the baud rate, see [Table 24-2](#).

Bit	15	14	13	12	11	10	9	8
	BAUD[15:8]							
Access	R/W	R/W	R/W	R/W	R/W	R/W	R/W	R/W
Reset	0	0	0	0	0	0	0	0
Bit	7	6	5	4	3	2	1	0
	BAUD[7:0]							
Access	R/W	R/W	R/W	R/W	R/W	R/W	R/W	R/W
Reset	0	0	0	0	0	0	0	0

#### Bits 15:8 – BAUD[15:8] USART Baud Rate High Byte

These bits hold the MSB of the 16-bit Baud register.

#### Bits 7:0 – BAUD[7:0] USART Baud Rate Low Byte

These bits hold the LSB of the 16-bit Baud register.

### 24.5.11 Debug Control Register

**Name:** DBGCTRL  
**Offset:** 0x0B  
**Reset:** 0x00  
**Property:** -

Bit	7	6	5	4	3	2	1	0
								DBGRUN
Access								R/W
Reset								0

#### Bit 0 – DBGRUN Debug Run

Value	Description
0	The peripheral is halted in Break Debug mode and ignores events
1	The peripheral will continue to run in Break Debug mode when the CPU is halted

### 24.5.12 IrDA Control Register

**Name:** EVCTRL  
**Offset:** 0x0C  
**Reset:** 0x00  
**Property:** -

Bit	7	6	5	4	3	2	1	0
								IREI
Access								R/W
Reset								0

**Bit 0 – IREI** IrDA Event Input Enable

This bit enables the event source for the IRCOM Receiver. If event input is selected for the IRCOM Receiver, the input from the USART's RX pin is automatically disabled.

### 24.5.13 IRCOM Transmitter Pulse Length Control Register

**Name:** TXPLCTRL  
**Offset:** 0x0D  
**Reset:** 0x00  
**Property:** -

Bit	7	6	5	4	3	2	1	0
	TXPL[7:0]							
Access	R/W	R/W	R/W	R/W	R/W	R/W	R/W	R/W
Reset	0	0	0	0	0	0	0	0

#### Bits 7:0 – TXPL[7:0] Transmitter Pulse Length

The 8-bit value sets the pulse modulation scheme for the transmitter. Setting this register will have effect only if IRCOM mode is selected by a USART. By leaving this register value to '0', 3/16 of the baud rate period pulse modulation is used. Setting this value from 1 to 254 will give a fixed pulse length coding. The 8-bit value sets the number of system clock periods for the pulse. The start of the pulse will be synchronized with the rising edge of the baud rate clock. Setting the value to 255 (0xFF) will disable pulse coding, letting the RX and TX signals pass through the IRCOM module unaltered. This enables other features through the IRCOM module, such as half-duplex USART, Loop-back testing, and USART RX input from an event channel.

TXPL must be configured before the USART transmitter is enabled (TXEN).

### 24.5.14 IRCOM Receiver Pulse Length Control Register

**Name:** RXPLCTRL  
**Offset:** 0x0E  
**Reset:** 0x00  
**Property:** -

Bit	7	6	5	4	3	2	1	0
	RXPL[6:0]							
Access		R/W	R/W	R/W	R/W	R/W	R/W	R/W
Reset		0	0	0	0	0	0	0

#### Bits 6:0 – RXPL[6:0] Receiver Pulse Length

The 8-bit value sets the filter coefficient for the IRCOM transceiver. Setting this register will only have effect if IRCOM mode is selected by a USART.

By leaving this register value to '0', filtering is disabled. Setting this value between 0x01 and 0xFF will enable filtering, where x+1 equal samples are required for the pulse to be accepted.

RXPL must be configured before USART receiver is enabled (RXEN).

## 25. SPI - Serial Peripheral Interface

### 25.1 Features

- Full-Duplex, Three-Wire Synchronous Data Transfer
- Master or Slave Operation
- LSB First or MSB First Data Transfer
- Seven Programmable Bit Rates
- End of Transmission Interrupt Flag
- Write Collision Flag Protection
- Wake-up from Idle Mode
- Double-Speed (CK/2) Master SPI Mode

### 25.2 Overview

The Serial Peripheral Interface (SPI) is a high-speed synchronous data transfer interface using three or four pins. It allows full-duplex communication between an AVR device and peripheral devices or between several microcontrollers. The SPI peripheral can be configured as either master or slave. The master initiates and controls all data transactions.

The interconnection between master and slave devices with SPI is shown in the block diagram. The system consists of two shift registers and a master clock generator. The SPI master initiates the communication cycle by pulling the desired slave's slave select ( $\overline{SS}$ ) signal low. Master and slave prepare the data to be sent to their respective Shift registers, and the master generates the required clock pulses on the SCK line to exchange data. Data is always shifted from master to slave on the master output, slave input (MOSI) line, and from slave to master on the master input, slave output (MISO) line.

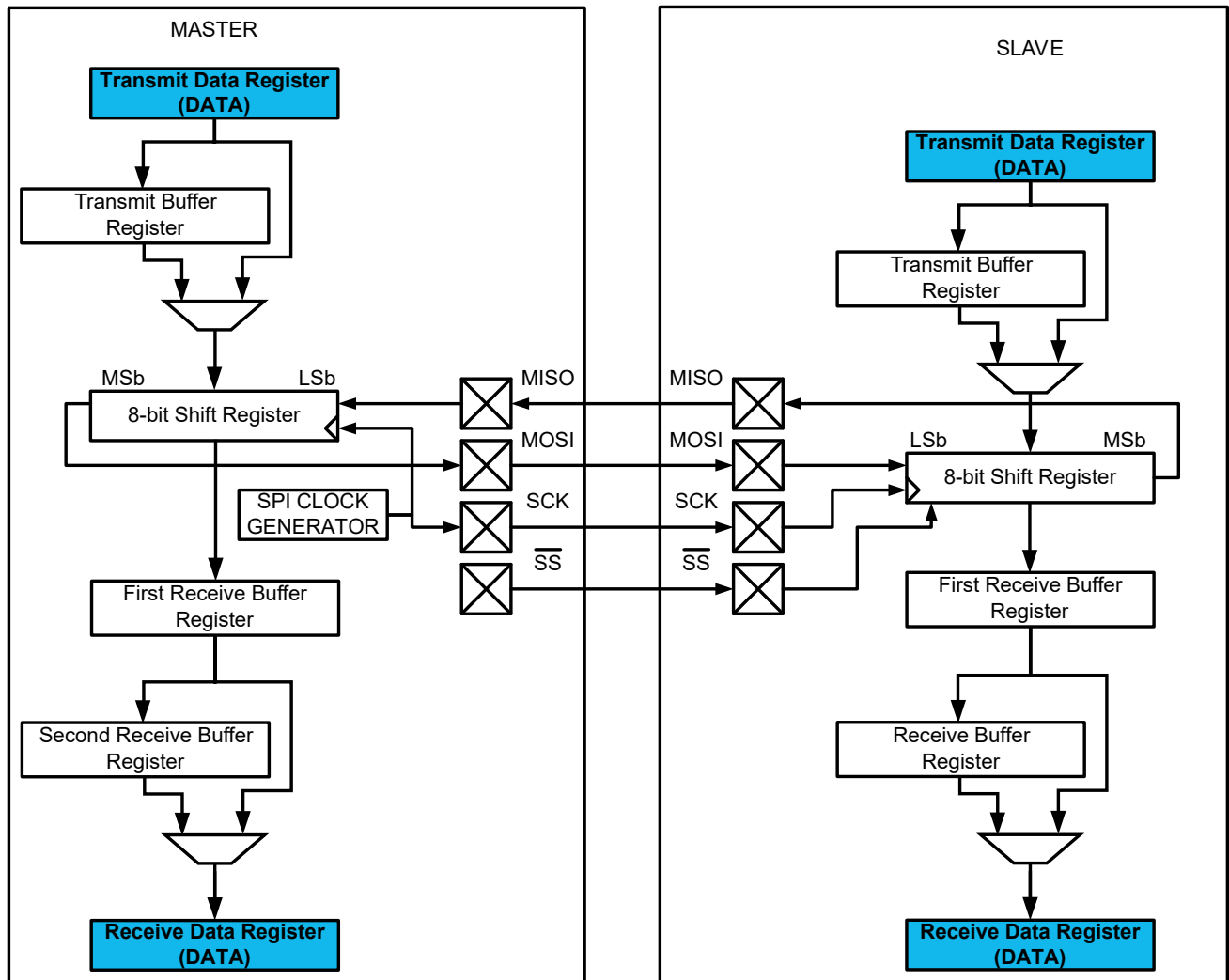
This device provides one instance of the SPI peripheral, SPI0.

#### Related Links

[25.2.1 Block Diagram](#)

25.2.1 Block Diagram

Figure 25-1. SPI Block Diagram



The SPI is built around an 8-bit Shift register that will shift data out and in at the same time. The Transmit Data register and the Receive Data register are not physical registers but are mapped to other registers when written or read: Writing the Transmit Data register (SPIn.DATA) will write the Shift register in Normal mode and the Transmit Buffer register in Buffer mode. Reading the Receive Data register (SPIn.DATA) will read the First Receive Buffer register in normal mode and the Second Receive Data register in Buffer mode.

In Master mode, the SPI has a clock generator to generate the SCK clock. In Slave mode, the received SCK clock is synchronized and sampled to trigger the shifting of data in the Shift register.



### 25.2.2 Signal Description

**Table 25-1. Signals in Master and Slave Mode**

Signal	Description	Pin Configuration	
		Master Mode	Slave Mode
MOSI	Master Out Slave In	User defined	Input
MISO	Master In Slave Out	Input	User defined
SCK	Slave clock	User defined	Input
$\overline{SS}$	Slave select	User defined	Input

When the SPI module is enabled, the data direction of the MOSI, MISO, SCK, and  $\overline{SS}$  pins is overridden according to [Table 25-1](#).

The data direction of the pins with "User defined" pin configuration is not controlled by the SPI: The data direction is controlled by the application software configuring the port peripheral. If these pins are configured with data direction as input, they can be used as regular I/O pin inputs. If these pins are configured with data direction as output, their output value is controlled by the SPI. The MISO pin has a special behavior: When the SPI is in Slave mode and the MISO pin is configured as an output, the  $\overline{SS}$  pin controls the output buffer of the pin: If  $\overline{SS}$  is low, the output buffer drives the pin, if  $\overline{SS}$  is high, the pin is tri-stated.

The data direction of the pins with "Input" pin configuration is controlled by the SPI hardware.

#### Related Links

[5. I/O Multiplexing and Considerations](#)

### 25.2.3 System Dependencies

In order to use this peripheral, other parts of the system must be configured correctly, as described below.

**Table 25-2. SPI System Dependencies**

Dependency	Applicable	Peripheral
Clocks	Yes	CLKCTRL
I/O Lines and Connections	Yes	PORT
Interrupts	Yes	CPUINT
Events	Yes	EVSYS
Debug	Yes	UPDI

#### Related Links

[25.2.3.2 I/O Lines and Connections](#)

[25.2.3.5 Debug Operation](#)

[25.2.3.3 Interrupts](#)

[25.2.3.1 Clocks](#)

#### 25.2.3.1 Clocks

This peripheral depends on the peripheral clock.

### Related Links

[10. CLKCTRL - Clock Controller](#)

#### 25.2.3.2 I/O Lines and Connections

The SPI signals (MOSI, MISO, SCK,  $\overline{SS}$ ) are either inputs or outputs, depending on whether the SPI is in Master or Slave mode, as described in the Signal Description.

Using the I/O lines requires configuration of the I/O pins as described in the Signal Description.

### Related Links

[5. I/O Multiplexing and Considerations](#)

[16. PORT - I/O Pin Configuration](#)

[25.2.2 Signal Description](#)

#### 25.2.3.3 Interrupts

Using the interrupts of this peripheral requires the interrupt controller to be configured first.

### Related Links

[13. CPUINT - CPU Interrupt Controller](#)

[8.7.3 SREG](#)

[25.3.3 Interrupts](#)

#### 25.2.3.4 Events

Not applicable.

#### 25.2.3.5 Debug Operation

When run-time debugging, this peripheral will continue normal operation. Halting the CPU in Debugging mode will halt normal operation of the peripheral.

If the peripheral is configured to require periodical service by the CPU through interrupts or similar, improper operation or data loss may result during halted debugging.

### Related Links

[33. UPDI - Unified Program and Debug Interface](#)

## 25.3 Functional Description

### 25.3.1 Initialization

Initialize the SPI to a basic functional state by following these steps:

1. Configure the  $\overline{SS}$  pin in the port peripheral.
2. Select SPI Master/Slave operation by writing the Master/Slave Select bit (MASTER) in the Control A register (SPIn.CTRLA).
3. In Master mode, select the clock speed by writing the Prescaler bits (PRESC) and the Clock Double bit (CLK2X) in SPIn.CTRLA.
4. Optional: Select the Data Transfer mode by writing to the MODE bits in the Control B register (SPIn.CTRLB).
5. Optional: Write the Data Order bit (DORD) in SPIn.CTRLA.
6. Optional: Setup Buffer mode by writing BUFEN and BUFWR bits in the Control B register (SPIn.CTRLB).

7. Optional: To disable the multi-master support in Master mode, write '1' to the Slave Select Disable bit (SSD) in SPIn.CTRLB.
8. Enable the SPI by writing a '1' to the ENABLE bit in SPIn.CTRLA.

### Related Links

- [5. I/O Multiplexing and Considerations](#)
- [16. PORT - I/O Pin Configuration](#)
- [25.2.2 Signal Description](#)

## 25.3.2 Operation

### 25.3.2.1 Master Mode Operation

When the SPI is configured in Master mode, a write to the SPIn.DATA register will start a new transfer. The SPI clock generator starts and the hardware shifts the eight bits into the selected slave. After the byte is shifted out the interrupt flag is set (IF flag in SPIn.INTFLAGS). The SPI master can operate in two modes, Normal and Buffered, as explained below.

#### 25.3.2.1.1 $\overline{SS}$ Pin Functionality in Master Mode - Multi-Master Support

In Master mode, the Slave Select Disable bit in Control Register B (SSD in SPIn.CTRLB) controls how the SPI uses the  $\overline{SS}$  line.

- If SSD in SPIn.CTRLB is zero, the SPI can use the  $\overline{SS}$  pin to transition from Master to Slave mode. This allows multiple SPI masters on the same SPI bus.
- If SSD in SPIn.CTRLB is '1', the SPI does not use the  $\overline{SS}$  pin, and it can be used as a regular I/O pin, or by other peripheral modules.

If SSD in SPIn.CTRLB is zero and the  $\overline{SS}$  is configured as an output pin, it can be used as a regular I/O pin, or by other peripheral modules, and will not affect the SPI system.

If the SSD bit in SPIn.CTRLB is zero and the  $\overline{SS}$  is configured as an input pin, the  $\overline{SS}$  pin must be held high to ensure master SPI operation. A low level will be interpreted as another master is trying to take control of the bus. This will switch the SPI into Slave mode and the hardware of the SPI will perform the following actions:

1. The master bit in the SPI Control A Register (MASTER in SPIn.CTRLA) is cleared and the SPI system becomes a slave. The direction of the pins will be switched according to [Table 25-3](#).
2. The interrupt flag in the Interrupt Flags register (IF flag in SPIn.INTFLAGS) will be set. If the interrupt is enabled and the global interrupts are enabled the interrupt routine will be executed.

**Table 25-3. Overview of the  $\overline{SS}$  Pin Functionality when the SSD Bit in SPIn.CTRLB is '0'**

$\overline{SS}$ Configuration	$\overline{SS}$ Pin-Level	Description
Input	High	Master activated (selected)
	Low	Master deactivated, switched to Slave mode
Output	High	Master activated (selected)
	Low	

### Note:

If the AVR device is configured for Master mode and it cannot be ensured that the  $\overline{SS}$  pin will stay high between two transmissions, the status of the Master bit (MASTER in SPIn.CTRLA) has to be checked before a new byte is written. After the Master bit has been cleared by a low level on the  $\overline{SS}$  line, it must be set by the application to re-enable the SPI Master mode.

### 25.3.2.1.2 Normal Mode

In Normal mode, the system is single-buffered in the transmit direction and double-buffered in the receive direction. This influences the data handling in the following ways:

1. New bytes to be sent cannot be written to the Data register (SPIn.DATA) before the entire transfer has completed. A premature write will cause corruption of the transmitted data, and the hardware will set the Write Collision Flag (WRCOL flag in SPIn.INTFLAGS).
2. Received bytes are written to the First Receive Buffer register immediately after the transmission is completed.
3. The First Receive Buffer register has to be read before the next transmission is completed or data will be lost. This register is read by reading SPIn.DATA.
4. The Transmit Buffer register and Second Receive Buffer register are not used in Normal mode.

After a transfer has completed, the Interrupt Flag will be set in the Interrupt Flags register (IF flag in SPI.INTFLAGS). This will cause the corresponding interrupt to be executed if this interrupt and the global interrupts are enabled. Setting the Interrupt Enable (IE) bit in the Interrupt Control register (SPIn.INTCTRL) will enable the interrupt.

### 25.3.2.1.3 Buffer Mode

The Buffer mode is enabled by setting the BUFEN bit in SPIn.CTRLB. The BUFWR bit in SPIn.CTRLB has no effect in Master mode. In Buffer mode, the system is double-buffered in the transmit direction and triple-buffered in the receive direction. This influences the data handling the following ways:

1. New bytes to be sent can be written to the Data register (SPIn.DATA) as long as the Data Register Empty Interrupt Flag (DREIF) in the Interrupt Flag Register (SPIn.INTFLAGS) is set. The first write will be transmitted right away and the following write will go to the Transmit Buffer register.
2. A received byte is placed in a two-entry RX FIFO comprised of the First and Second Receive Buffer registers immediately after the transmission is completed.
3. The Data register is used to read from the RX FIFO. The RX FIFO must be read at least every second transfer to avoid any loss of data.

If both the Shift register and the Transmit Buffer register becomes empty, the Transfer Complete Interrupt Flag (TxCIF) in the Interrupt Flags register (SPIn.INTFLAGS) will be set. This will cause the corresponding interrupt to be executed if this interrupt and the global interrupts are enabled. Setting the Transfer Complete Interrupt Enable (TxCIE) in the Interrupt Control register (SPIn.INTCTRL) enables the Transfer Complete Interrupt.

### 25.3.2.2 Slave Mode

In Slave mode, the SPI peripheral receives SPI clock and Slave Select from a Master. Slave mode supports three operational modes: One unbuffered mode and two buffered modes. In Slave mode, the control logic will sample the incoming signal on the SCK pin. To ensure correct sampling of this clock signal, the minimum low and high periods must each be longer than two peripheral clock cycles.

#### 25.3.2.2.1 $\overline{SS}$ Pin Functionality in Slave Mode

The Slave Select ( $\overline{SS}$ ) pin plays a central role in the operation of the SPI. Depending on the mode the SPI is in and the configuration of this pin, it can be used to activate or deactivate devices. The  $\overline{SS}$  pin is used as a Chip Select pin.

In Slave mode,  $\overline{SS}$ , MOSI, and SCK are always inputs. The behavior of the MISO pin depends on the configured data direction of the pin in the port peripheral and the value of  $\overline{SS}$ :

- When  $\overline{SS}$  is driven low, the SPI is activated and will respond to received SCK pulses by clocking data out on MISO if the user has configured the data direction of the MISO pin as an output.
- When  $\overline{SS}$  is driven high the SPI is deactivated, meaning that it will not receive incoming data. If the MISO pin data direction is configured as an output, the MISO pin will be tri-stated.

The following table shows an overview of the  $\overline{SS}$  pin functionality.

**Table 25-4. Overview of the  $\overline{SS}$  Pin Functionality**

$\overline{SS}$ Configuration	$\overline{SS}$ Pin-Level	Description	MISO Pin Mode	
			Port Direction = Output	Port Direction = Input
Always Input	High	Slave deactivated (deselected)	Tri-stated	Input
	Low	Slave activated (selected)	Output	Input

**Note:**

In Slave mode, the SPI state machine will be reset when the  $\overline{SS}$  pin is brought high. If the  $\overline{SS}$  is brought high during a transmission, the SPI will immediately stop sending and receiving - both data received and data sent must be considered as lost. As the  $\overline{SS}$  pin is used to signal the start and end of a transfer, it is useful for achieving packet/byte synchronization, and keeping the Slave bit counter synchronized with the master clock generator.

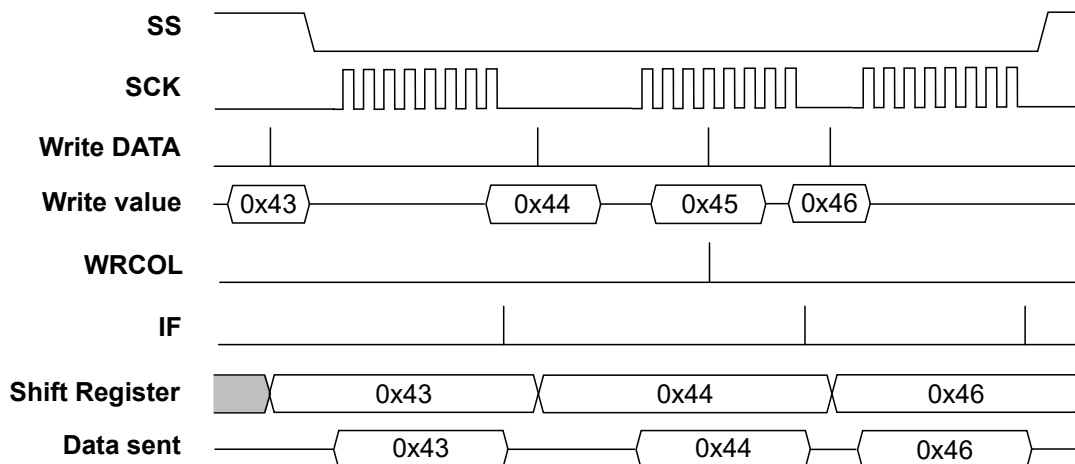
**25.3.2.2.2 Normal Mode**

In Normal mode, the SPI peripheral will remain idle as long as the  $\overline{SS}$  pin is driven high. In this state, the software may update the contents of the SPIn.DATA register, but the data will not be shifted out by incoming clock pulses on the SCK pin until the  $\overline{SS}$  pin is driven low. If  $\overline{SS}$  is driven low, the slave will start to shift out data on the first SCK clock pulse. When one byte has been completely shifted, the SPI Interrupt flag (IF) in SPIn.INTFLAGS is set.

The user application may continue placing new data to be sent into the SPIn.DATA register before reading the incoming data. New bytes to be sent cannot be written to SPIn.DATA before the entire transfer has completed. A premature write will be ignored, and the hardware will set the Write Collision Flag (WRCOL in SPIn.INTFLAGS).

When  $\overline{SS}$  is driven high, the SPI logic is halted, and the SPI slave will not receive any new data. Any partially received packet in the shift register will be lost.

**Figure 25-2. SPI Timing Diagram in Normal Mode (Buffer Mode Not Enabled)**



The figure above shows three transfers and one write to the DATA register while the SPI is busy with a transfer. This write will be ignored and the Write Collision Flag (WRCOL in SPIn.INTFLAGS) is set.

### 25.3.2.2.3 Multi Slave Systems - $\overline{SS}$ Pin Functionality

The Slave Select ( $\overline{SS}$ ) pin plays a central role in the SPI configuration. Depending on the mode the part is running in and the configuration of this pin, it can be used to activate or deactivate the devices. The  $\overline{SS}$  pin can be compared with a chip select pin that has some extra features.

In Master mode, the  $\overline{SS}$  pin must be held high to ensure master SPI operation if this pin is configured as an input pin. A low level will switch the SPI into Slave mode and the hardware of the SPI will perform the following actions:

1. The master bit (MSTR) in the SPI Control Register (SPCR) is cleared and the SPI system becomes a slave. The direction of the pins will be switched according to [Table 25-5](#).
2. The SPI Interrupt Flag (SPIF) in the SPI Status Register (SPSR) will be set. If the SPI interrupt and the global interrupts are enabled the interrupt routine will be executed.

This can be useful in systems with more than one master to avoid two masters accessing the SPI bus at the same time. If the  $\overline{SS}$  pin is configured as output pin it can be used as a general purpose output pin, which does not affect the SPI system.

**Note:** In cases where the AVR is configured for Master mode and it can not be ensured that the  $\overline{SS}$  pin will stay high between two transmissions, the status of the MSTR bit has to be checked before a new byte is written. After the MSTR bit has been cleared by a low level on the  $\overline{SS}$  line, it must be set by the application to re-enable SPI Master mode.

In Slave mode the  $\overline{SS}$  pin is always an input. When  $\overline{SS}$  is held low, the SPI is activated and MISO becomes output if configured so by the user. All other pins are inputs. When  $\overline{SS}$  is driven high, all pins are inputs, and the SPI is passive, which means that it will not receive incoming data. The following table shows an overview of the  $\overline{SS}$  Pin Functionality.

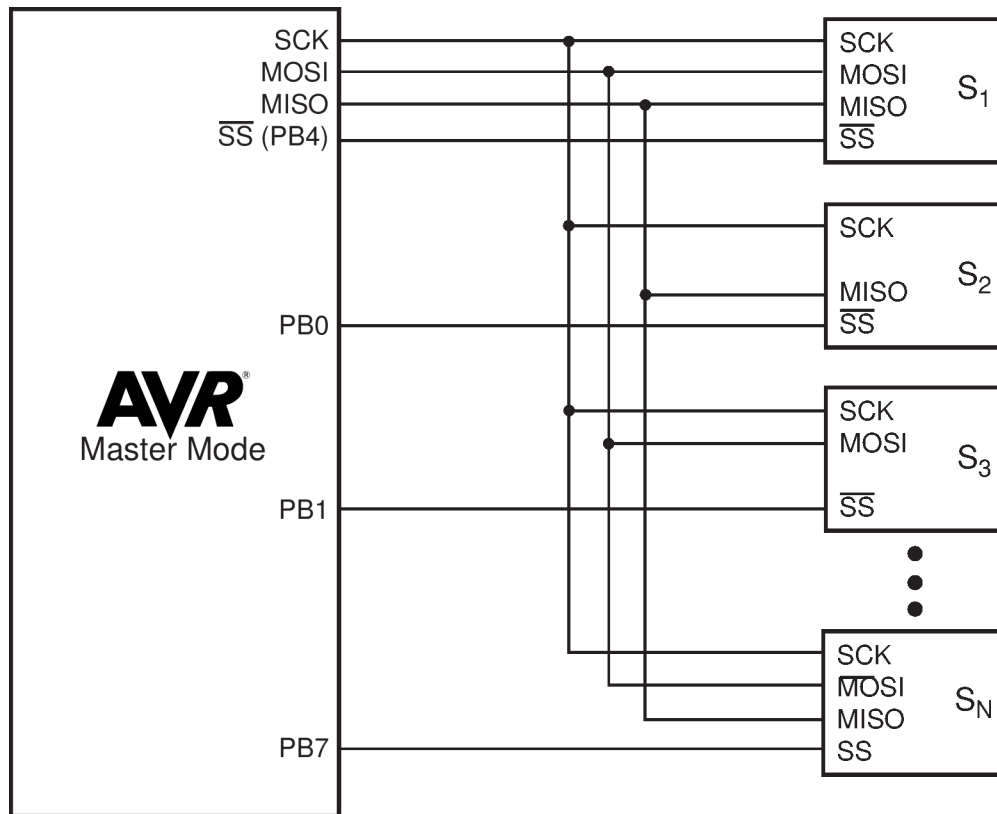
**Table 25-5. Overview of the  $\overline{SS}$  Pin Functionality**

Mode	$\overline{SS}$ Configuration	$\overline{SS}$ Pin-level	Description
Slave	Always Input	High	Slave deactivated (deselected)
		Low	Slave activated (selected)
Master	Input	High	Master activated (selected)
		Low	Master deactivated, switched to Slave mode
	Output	High	Master activated (selected)
		Low	

**Note:** In Slave mode, the SPI logic will be Reset once the  $\overline{SS}$  pin is brought high. If the  $\overline{SS}$  pin is brought high during a transmission, the SPI will stop sending and receiving immediately and both data received and data sent must be considered as lost.

As shown in the preceding table, the  $\overline{SS}$  pin in Slave mode is always an input pin. A low level activates the SPI of the device while a high level causes its deactivation. A Single Master Multiple Slave System with an AVR configured in Master mode and  $\overline{SS}$  configured as output pin is shown in the following figure. The amount of slaves that can be connected to this AVR is only limited by the number of I/O pins to generate the slave select signals.

**Figure 25-3. Multi Slave System**



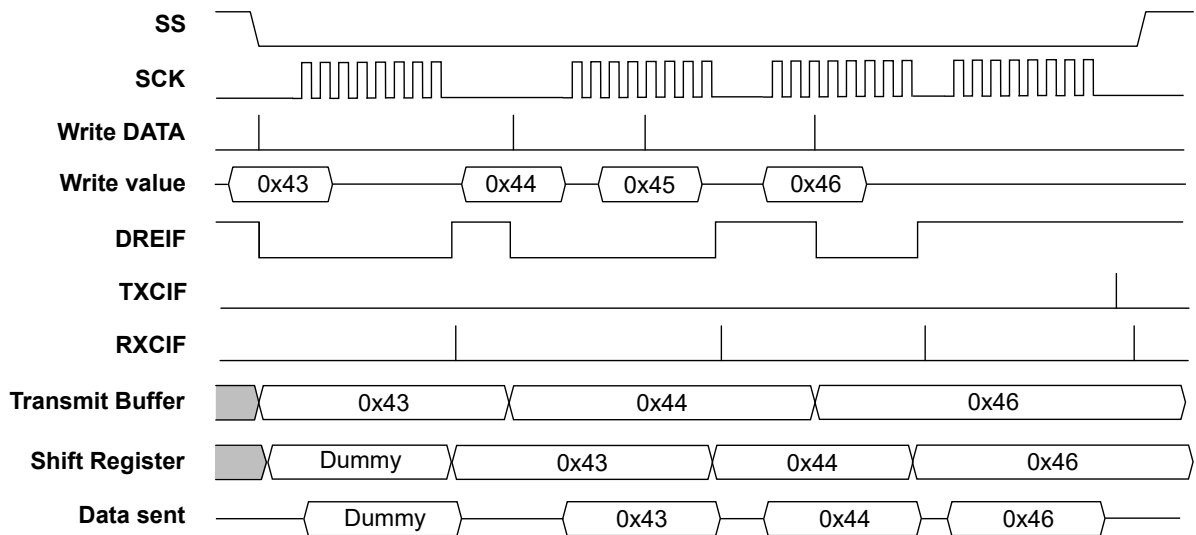
The ability to connect several devices to the same SPI bus is based on the fact that only one master and only one slave is active at the same time. The MISO, MOSI, and SCK lines of all the other slaves are tri-stated (configured as input pins of a high impedance with no pullup resistors enabled). A false implementation (for example, if two slaves are activated at the same time) can cause a driver contention which can lead to a CMOS latch-up state and must be avoided. Resistances of 1 to 10Ω in series with the pins of the SPI can be used to prevent the system from latching up. However this affects the maximum usable data rate, depending on the loading capacitance on the SPI pins.

Unidirectional SPI devices require just the clock line and one of the data lines. The device can use MISO line or the MOSI line depending on its purpose.

#### 25.3.2.2.4 Buffer Mode

To avoid data collisions, the SPI peripheral can be configured in buffered mode by writing a '1' to the Buffer Mode Enable bit in the Control B register (BUFEN in SPIn.CTRLB). In this mode, the SPI has additional interrupt flags and extra buffers. The extra buffers are shown in [Figure 25-1](#). There are two different modes for the Buffer mode, selected with the Buffer mode Wait for Receive bit (BUFWR). The two different modes are described below with timing diagrams.

**Figure 25-4. SPI Timing Diagram in Buffer Mode with BUFWR in SPIn.CTRLB Written to '0'**

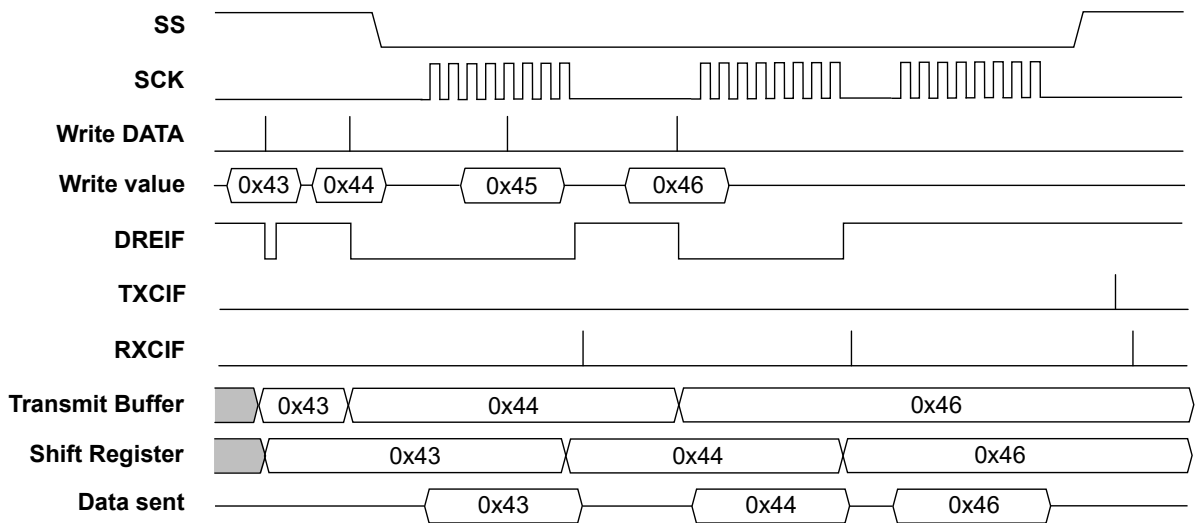


All writes to the Data register goes to the Transmit Buffer register. The figure above shows that the value 0x43 is written to the Data register, but it is not immediately transferred to the shift register so the first byte sent will be a dummy byte. The value of the dummy byte is whatever was in the shift register at the time, usually the last received byte. After the first dummy transfer is completed the value 0x43 is transferred to the Shift register. Then 0x44 is written to the Data register and goes to the Transmit Buffer register. A new transfer is started and 0x43 will be sent. The value 0x45 is written to the Data register, but the Transmit Buffer register is not updated since it is already full containing 0x44 and the Data Register Empty Interrupt Flag (DREIF in SPIn.INTFLAGS) is low. The value 0x45 will be lost. After the transfer, the value 0x44 is moved to the Shift register. During the next transfer, 0x46 is written to the Data register and 0x44 is sent out. After the transfer is complete, 0x46 is copied into the Shift register and sent out in the next transfer.

The Data Register Empty Interrupt Flag (DREIF in SPIn.INTFLAGS) goes low every time the Transmit Buffer register is written and goes high after a transfer when the previous value in the Transmit Buffer register is copied into the Shift register. The Receive Complete Interrupt Flag (RXCIF in SPIn.INTFLAGS) is set one cycle after the Data Register Empty Interrupt Flag goes high. The Transfer Complete Interrupt Flag is set one cycle after the Receive Complete Interrupt Flag is set when both the value in the shift register and the Transmit Buffer register have been sent.



**Figure 25-5. SPI Timing Diagram in Buffer Mode with CTRLB.BUFWR Written to '1'**



All writes to the Data register goes to the transmit buffer. The figure above shows that the value 0x43 is written to the Data register and since the Slave Select pin is high it is copied to the Shift register the next cycle. Then the next write (0x44) will go to the Transmit Buffer register. During the first transfer, the value 0x43 will be shifted out. In the figure, the value 0x45 is written to the Data register, but the Transmit Buffer register is not updated since the Data Register Empty Interrupt Flag is low. After the transfer is completed, the value 0x44 from the Transmit Buffer register is copied over to the Shift register. The value 0x46 is written to the Transmit Buffer register. During the next two transfers, 0x44 and 0x46 are shifted out. The flags behave the same as with Buffer mode Wait for Receive Bit (`BUFWR` in `SPIn.CTRLB`) written to '0'.

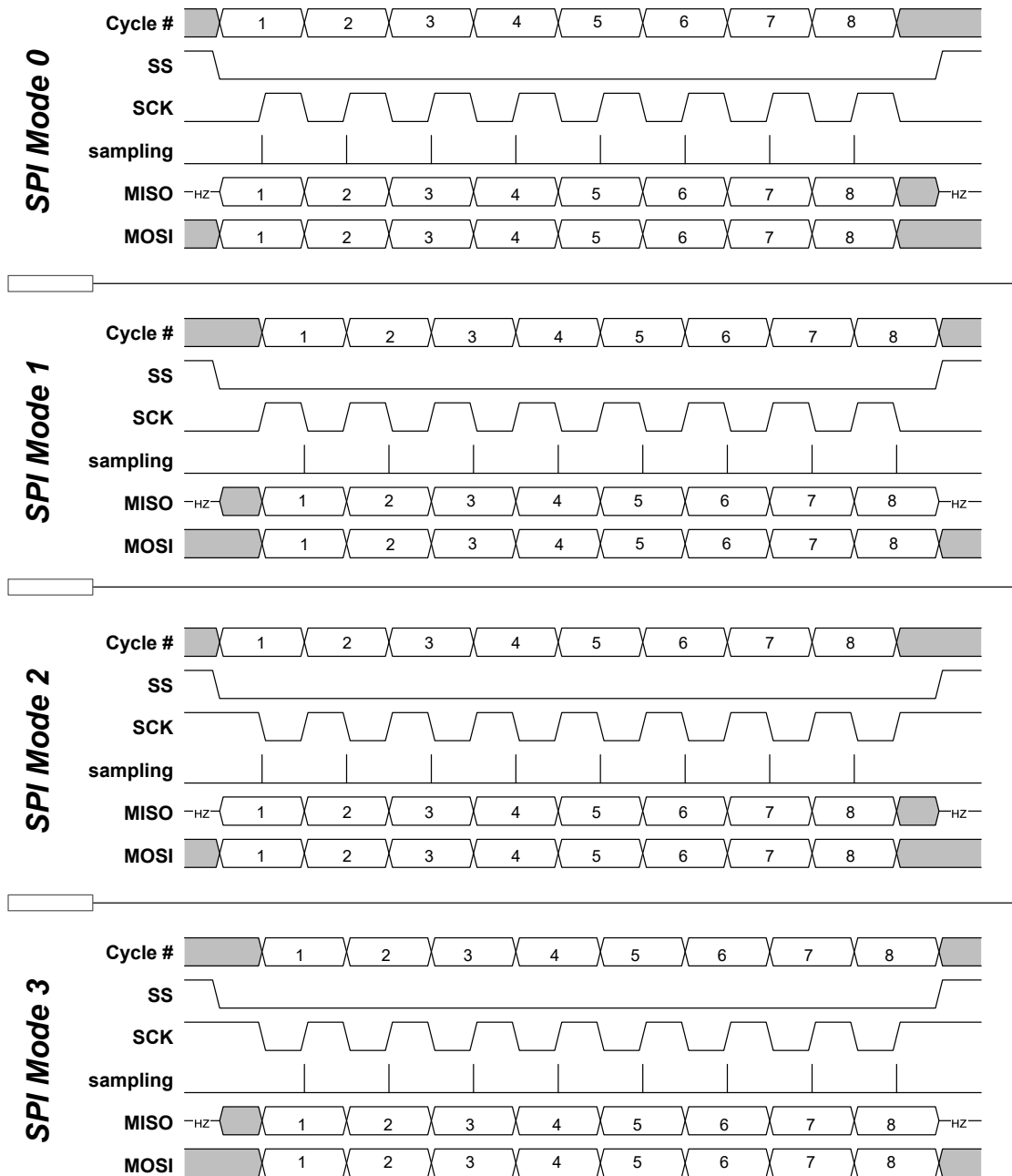
### 25.3.2.3 Data Modes

There are four combinations of the SCK phase and polarity with respect to serial data. The desired combination is selected by writing to the MODE bits in the Control B register (`SPIn.CTRLB`).

The SPI data transfer formats are shown below. Data bits are shifted out and latched in on opposite edges of the SCK signal, ensuring sufficient time for data signals to stabilize.

The leading edge is the first clock edge of a clock cycle. The trailing edge is the last clock edge of a clock cycle.

**Figure 25-6. SPI Data Transfer Modes**



### 25.3.3 Interrupts

**Table 25-6. Available Interrupt Vectors and Sources**

Offset	Name	Vector Description	Conditions
0x00	SPI	SPI interrupt	<ul style="list-style-type: none"> <li>• SSI: Slave Select Trigger Interrupt</li> <li>• DRE: Data Register Empty Interrupt</li> <li>• TXC: Transfer Complete Interrupt</li> </ul>

Offset	Name	Vector Description	Conditions
			<ul style="list-style-type: none"> <li>RXC: Receive Complete Interrupt</li> </ul>

When an interrupt condition occurs, the corresponding interrupt flag is set in the Interrupt Flags register of the peripheral (*peripheral*.INTFLAGS).

An interrupt source is enabled or disabled by writing to the corresponding enable bit in the peripheral's Interrupt Control register (*peripheral*.INTCTRL).

An interrupt request is generated when the corresponding interrupt source is enabled and the interrupt flag is set. The interrupt request remains active until the interrupt flag is cleared. See the peripheral's INTFLAGS register for details on how to clear interrupt flags.

### Related Links

[8.7.3 SREG](#)

[13. CPUINT - CPU Interrupt Controller](#)

### 25.3.4 Sleep Mode Operation

The SPI will continue working in Idle Sleep mode. When entering any deeper sleep mode, an active transaction will be stopped.

### Related Links

[11. SLPCTRL - Sleep Controller](#)

### 25.3.5 Configuration Change Protection

Not applicable.

### 25.4 Register Summary - SPI

Offset	Name	Bit Pos.							
0x00	<a href="#">CTRLA</a>	7:0		DORD	MASTER	CLK2X		PRESC[1:0]	ENABLE
0x01	<a href="#">CTRLB</a>	7:0	BUFEN	BUFWR				SSD	MODE[1:0]
0x02	<a href="#">INTCTRL</a>	7:0	RXCIE	TXCIE	DREIE	SSIE			IE
0x03	<a href="#">INTFLAGS</a>	7:0	RXCIF/IF	TXCIF/ WRCOL	DREIF	SSIF			BUFOVF
0x04	<a href="#">DATA</a>	7:0	DATA[7:0]						

### 25.5 Register Description

### 25.5.1 Control A

**Name:** CTRLA  
**Offset:** 0x00  
**Reset:** 0x00  
**Property:** -

Bit	7	6	5	4	3	2	1	0
		DORD	MASTER	CLK2X		PRESC[1:0]		ENABLE
Access		R/W	R/W	R/W		R/W	R/W	R/W
Reset		0	0	0		0	0	0

#### Bit 6 – DORD Data Order

Value	Description
0	The MSB of the data word is transmitted first
1	The LSB of the data word is transmitted first

#### Bit 5 – MASTER Master/Slave Select

This bit selects the desired SPI mode.

If  $\overline{SS}$  is configured as input and driven low while this bit is '1', this bit is cleared, and the IF flag in SPIn.INTFLAGS is set. The user has to write MASTER=1 again to re-enable SPI Master mode.

This behavior is controlled by the Slave Select Disable bit (SSD) in SPIn.CTRLB.

Value	Description
0	SPI Slave mode selected
1	SPI Master mode selected

#### Bit 4 – CLK2X Clock Double

When this bit is written to '1' the SPI speed (SCK frequency, after internal prescaler) is doubled in Master mode.

Value	Description
0	SPI speed (SCK frequency) is not doubled
1	SPI speed (SCK frequency) is doubled in Master mode

#### Bits 2:1 – PRESC[1:0] Prescaler

This bit field controls the SPI clock rate configured in Master mode. These bits have no effect in Slave mode. The relationship between SCK and the peripheral clock frequency ( $f_{CLK\_PER}$ ) is shown below.

The output of the SPI prescaler can be doubled by writing the CLK2X bit to '1'.

Value	Name	Description
0x0	DIV4	CLK_PER/4
0x1	DIV16	CLK_PER/16
0x2	DIV64	CLK_PER/64
0x3	DIV128	CLK_PER/128

#### Bit 0 – ENABLE SPI Enable

---

---

Value	Description
0	SPI is disabled
1	SPI is enabled

### 25.5.2 Control B

**Name:** CTRLB  
**Offset:** 0x01  
**Reset:** 0x00  
**Property:** -

Bit	7	6	5	4	3	2	1	0
	BUFEN	BUFWR				SSD	MODE[1:0]	
Access	R/W	R/W				R/W	R/W	R/W
Reset	0	0				0	0	0

#### Bit 7 – BUFEN Buffer Mode Enable

Writing this bit to '1' enables Buffer mode, meaning two buffers in receive direction, one buffer in transmit direction, and separate interrupt flags for both transmit complete and receive complete.

#### Bit 6 – BUFWR Buffer Mode Wait for Receive

When writing this bit to '0' the first data transferred will be a dummy sample.

Value	Description
0	One SPI transfer must be completed before the data is copied into the Shift register.
1	When writing to the data register when the SPI is enabled and $\overline{SS}$ is high, the first write will go directly to the Shift register.

#### Bit 2 – SSD Slave Select Disable

When this bit is set and when operating as SPI Master (MASTER=1 in SPIn.CTRLA),  $\overline{SS}$  does not disable Master mode.

Value	Description
0	Enable the Slave Select line when operating as SPI Master
1	Disable the Slave Select line when operating as SPI Master

#### Bits 1:0 – MODE[1:0] Mode

These bits select the Transfer mode. The four combinations of SCK phase and polarity with respect to the serial data are shown in the table below. These bits decide whether the first edge of a clock cycle (leading edge) is rising or falling and whether data setup and sample occur on the leading or trailing edge. When the leading edge is rising, the SCK signal is low when idle, and when the leading edge is falling, the SCK signal is high when idle.

Value	Name	Description
0x0	0	Leading edge: Rising, sample Trailing edge: Falling, setup
0x1	1	Leading edge: Rising, setup Trailing edge: Falling, sample
0x2	2	Leading edge: Falling, sample Trailing edge: Rising, setup
0x3	3	Leading edge: Falling, setup Trailing edge: Rising, sample

**Related Links**

[25.3.2.3 Data Modes](#)



### 25.5.3 Interrupt Control

**Name:** INTCTRL  
**Offset:** 0x02  
**Reset:** 0x00  
**Property:** -

Bit	7	6	5	4	3	2	1	0
	RXCIE	TXCIE	DREIE	SSIE				IE
Access	R/W	R/W	R/W	R/W				R/W
Reset	0	0	0	0				0

**Bit 7 – RXCIE** Receive Complete Interrupt Enable

In Buffer mode, this bit enables the receive complete interrupt. The enabled interrupt will be triggered when the RXCIF flag in the SPIn.INTFLAGS register is set. In the Non-Buffer mode, this bit is '0'.

**Bit 6 – TXCIE** Transfer Complete Interrupt Enable

In Buffer mode, this bit enables the transfer complete interrupt. The enabled interrupt will be triggered when the TXCIF flag in the SPIn.INTFLAGS register is set. In the Non-Buffer mode, this bit is '0'.

**Bit 5 – DREIE** Data Register Empty Interrupt Enable

In Buffer mode, this bit enables the data register empty interrupt. The enabled interrupt will be triggered when the DREIF flag in the SPIn.INTFLAGS register is set. In the Non-Buffer mode, this bit is '0'.

**Bit 4 – SSIE** Slave Select Trigger Interrupt Enable

In Buffer mode, this bit enables the Slave Select interrupt. The enabled interrupt will be triggered when the SSIF flag in the SPIn.INTFLAGS register is set. In the Non-Buffer mode, this bit is '0'.

**Bit 0 – IE** Interrupt Enable

This bit enables the SPI interrupt when the SPI is not in Buffer mode. The enabled interrupt will be triggered when RXCIF/IF is set in the SPIn.INTFLAGS register.

### 25.5.4 Interrupt Flags

**Name:** INTFLAGS  
**Offset:** 0x03  
**Reset:** 0x00  
**Property:** -

Bit	7	6	5	4	3	2	1	0
	RXCIF/IF	TXCIF/WRCOL	DREIF	SSIF				BUFOVF
Access	R/W	R/W	R/W	R/W				R/W
Reset	0	0	0	0				0

#### Bit 7 – RXCIF/IF Receive Complete Interrupt Flag/Interrupt Flag

**RXCIF:** In Buffer mode, this flag is set when there is unread data in the receive buffer and cleared when the receive buffer is empty (i.e., does not contain any unread data). In the Non-Buffer mode, this bit does not have any effect.

When interrupt-driven data reception is used, the receive complete interrupt routine must read the received data from SPIn.DATA in order to clear RXCIF. If not, a new interrupt will occur directly after the return from the current interrupt. This flag can also be cleared by writing a '1' to its bit location.

**IF:** This flag is set when a serial transfer is complete and one byte is completely shifted in/out of the SPIn.DATA register. If  $\overline{SS}$  is configured as input and is driven low when the SPI is in Master mode, this will also set this flag. IF is cleared by hardware when executing the corresponding interrupt vector. Alternatively, the IF flag can be cleared by first reading the SPIn.INTFLAGS register when IF is set, and then accessing the SPIn.DATA register.

#### Bit 6 – TXCIF/WRCOL Transfer Complete Interrupt Flag/Write Collision Flag

**TXCIF:** In Buffer mode, this flag is set when all the data in the transmit shift register has been shifted out and there is no new data in the transmit buffer (SPIn.DATA). The flag is cleared by writing a '1' to its bit location. In the Non-Buffer mode, this bit does not have any effect.

**WRCOL:** The WRCOL flag is set if the SPIn.DATA register is written to before a complete byte has been shifted out. This flag is cleared by first reading the SPIn.INTFLAGS register when WRCOL is set, and then accessing the SPIn.DATA register.

#### Bit 5 – DREIF Data Register Empty Interrupt Flag

In Buffer mode, this flag indicates whether the transmit buffer (SPIn.DATA) is ready to receive new data. The flag is '1' when the transmit buffer is empty and '0' when the transmit buffer contains data to be transmitted that has not yet been moved into the Shift register. DREIF is set to '0' after a reset to indicate that the transmitter is ready. In the Non-Buffer mode, this bit is always '0'.

DREIF is cleared by writing SPIn.DATA. When interrupt-driven data transmission is used, the software must either write new data to SPIn.DATA in order to clear DREIF or disable the Data register empty interrupt. If not, a new interrupt will occur directly after the return from the current interrupt.

#### Bit 4 – SSIF Slave Select Trigger Interrupt Flag

In Buffer mode, this flag indicates that the SPI has been in Master mode and the SS line has been pulled low externally so the SPI is now working in Slave mode. The flag will only be set if the Slave Select

Disable bit (SSD) is not '1'. The flag is cleared by writing a '1' to its bit location. In the Non-Buffer mode, this bit is always '0'.

### **Bit 0 – BUFOVF** Buffer Overflow

This flag is only used in Buffer mode. This flag indicates data loss due to a receiver buffer full condition. This flag is set if a buffer overflow condition is detected. A buffer overflow occurs when the receive buffer is full (two characters) and a third byte has been received in the Shift register. If there is no transmit data the buffer overflow will not be set before the start of a new serial transfer. This flag is valid until the receive buffer (SPIn.DATA) is read. Always write this bit location to '0' when writing the SPIn.INTFLAGS register. In the Non-Buffer mode, this bit is always '0'.

### 25.5.5 Data

**Name:** DATA  
**Offset:** 0x04  
**Reset:** 0x00  
**Property:** -

Bit	7	6	5	4	3	2	1	0
	DATA[7:0]							
Access	R/W	R/W	R/W	R/W	R/W	R/W	R/W	R/W
Reset	0	0	0	0	0	0	0	0

#### Bits 7:0 – DATA[7:0] SPI Data

The SPIn.DATA register is used for sending and receiving data. Writing to the register initiates the data transmission, and the byte written to the register will be shifted out on the SPI output line.

Reading this register in Buffer mode will read the second receive buffer and the contents of the first receive buffer will be moved to the second receive buffer.

## 26. TWI - Two-Wire Interface

### 26.1 Features

- Bidirectional, Two-Wire Communication Interface
- Philips I<sup>2</sup>C compatible:
  - Standard mode (Sm/100 kHz with slew-rate limited output)
  - Fast mode (Fm/400 kHz with slew-rate limited output)
  - Fast mode plus (Fm+/1 MHz with ×10 output drive strength)
- System Management Bus (SMBus) Compatible (100 kHz with Slew-Rate Limited Output):
  - Support arbitration between start/repeated start and data bit
  - Slave arbitration allows support for the Address Resolution Protocol (ARP)
  - Configurable SMBus Layer 1 time-outs in hardware
  - Independent time-outs for Dual mode
- Independent Master and Slave Operation:
  - Combined (same pins) or Dual mode (separate pins)
  - Single or multi-master bus operation with full arbitration support
- Flexible Slave Address Match Hardware Operating in All Sleep Modes, Including Power-Down:
  - 7-bit and general call address recognition
  - 10-bit addressing support in collaboration with software
  - Address mask register allows address range masking - alternatively, it can be used as a secondary address match
  - Optional software address recognition for an unlimited number of addresses
- Input Filter For Bus Noise Suppression

### 26.2 Overview

The Two-Wire Interface (TWI) peripheral is a bidirectional, two-wire communication interface. It is I<sup>2</sup>C and System Management Bus (SMBus) compatible. The only external hardware needed to implement the bus is one pull-up resistor on each bus line.

Any device connected to the bus must act as a master or a slave. The master initiates a data transaction by addressing a slave on the bus and telling whether it wants to transmit or receive data. One bus can have many slaves and one or several masters that can take control of the bus. An arbitration process handles priority if more than one master tries to transmit data at the same time. Mechanisms for resolving bus contention are inherent in the protocol.

The TWI peripheral supports master and slave functionality. The master and slave functionality are separated from each other and can be enabled and configured separately. The master module supports multi-master bus operation and arbitration. It contains the Baud Rate Generator. All 100 kHz, 400 kHz, and 1 MHz bus frequencies are supported. Quick command and Smart mode can be enabled to auto-trigger operations and reduce software complexity.

The slave module implements 7-bit address match and general address call recognition in hardware. 10-bit addressing is supported. A dedicated Address Mask register can act as a Second Address match register or as a register for address range masking. The slave continues to operate in all Sleep modes,

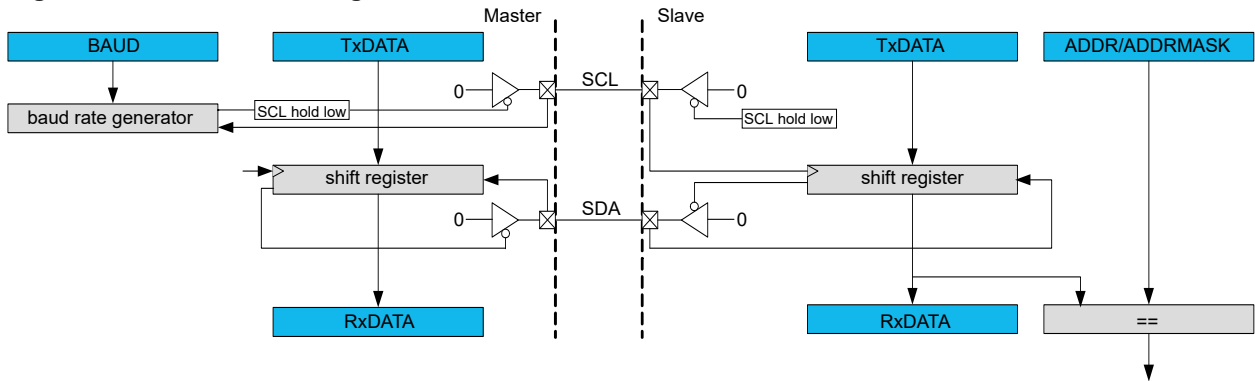
including Power-Down mode. This enables the slave to wake-up the device from all Sleep modes on TWI address match. It is possible to disable the address matching to let this be handled in software instead.

The TWI peripheral will detect Start and Stop conditions, bus collisions, and bus errors. Arbitration lost, errors, collision, and clock hold on the bus are also detected and indicated in separate status flags available in both Master and Slave modes.

This device provides one instance of the TWI peripheral; TWI0.

### 26.2.1 Block Diagram

**Figure 26-1. TWI Block Diagram**



### 26.2.2 Signal Description

Signal	Description	Type
SCL	Serial clock line	Digital I/O
SDA	Serial data line	Digital I/O

#### Related Links

[5. I/O Multiplexing and Considerations](#)

### 26.2.3 System Dependencies

In order to use this peripheral, other parts of the system must be configured correctly, as described below.

**Table 26-1. TWI System Dependencies**

Dependency	Applicable	Peripheral
Clocks	Yes	CLKCTRL
I/O Lines and Connections	Yes	PORT
Interrupts	Yes	CPUINT
Events	No	-
Debug	Yes	UPDI

#### Related Links

[26.2.3.1 Clocks](#)

[26.2.3.5 Debug Operation](#)

[26.2.3.2 I/O Lines and Connections](#)

### [26.2.3.3 Interrupts](#)

#### 26.2.3.1 Clocks

This peripheral requires the system clock (CLK\_PER). The relationship between CLK\_PER and the TWI bus clock (SCL) is explained in the TWI.MBAUD register.

#### Related Links

[10. CLKCTRL - Clock Controller](#)

[26.5.6 MBAUD](#)

#### 26.2.3.2 I/O Lines and Connections

Using the I/O lines of the peripheral requires configuration of the I/O pins.

#### 26.2.3.3 Interrupts

Using the interrupts of this peripheral requires the interrupt controller to be configured first.

#### 26.2.3.4 Events

Not applicable.

#### 26.2.3.5 Debug Operation

When run-time debugging, this peripheral will continue normal operation. Halting the CPU in Debugging mode will halt normal operation of the peripheral.

This peripheral can be forced to operate with halted CPU by writing a '1' to the Debug Run bit (DBGRUN) in the Debug Control register of the peripheral (*peripheral*.DBGCTRL).

When the CPU is halted in Debug mode and DBGRUN=1, reading/writing the DATA register will neither trigger a bus operation nor cause transmit and clear flags.

If the peripheral is configured to require periodical service by the CPU through interrupts or similar, improper operation or data loss may result during halted debugging.

#### Related Links

[33. UPDI - Unified Program and Debug Interface](#)

## 26.3 Functional Description

### 26.3.1 Initialization

Before enabling the master or the slave unit, ensure that the correct settings for SDASETUP, SDAHOLD, and, if used, Fast-mode plus (FMPEN) are stored in TWI.CTRLA. If alternate pins are to be used for the slave, this must be specified in the TWIn.DUALCTRL register as well. Note that for dual mode the master enables the primary SCL/SDA pins, while the ENABLE bit in TWIn.DUALCTRL enables the secondary pins.

#### Master Operation

It is recommended to write to the Master Baud Rate register (TWIn.BAUD) before enabling the TWI master since TIMEOUT is dependent on the baud rate setting. To start the TWI master, write a '1' to the ENABLE bit and configure an appropriate TIMEOUT if using the TWI in an SMBus environment. The ENABLE and TIMEOUT bits are all located in the Master Control A register (TWIn.MCTRLA). If no TIMEOUT value is set, which is the case for I<sup>2</sup>C operation, the bus state must be manually set to IDLE by writing 0x1 to BUSSTATE in TWIn.MSTATUS at a safe point in time. Note that unlike the SMBus specification, the I<sup>2</sup>C specification does not specify when it is safe to assume that the bus is idle in a

multi-master system. The application can solve this by ensuring that after all masters connected to the bus are enabled, one supervising master performs a transfer before any of the other masters. The stop condition of this initial transfer will indicate to the Bus State Monitor logic that the bus is idle and ready.

### Slave Operation

To start the TWI slave, write the Slave Address (TWIn.SADDR), and write a '1' to the ENABLE bit in the Slave Control A register (TWIn.SCTRLA). The TWI peripheral will wait to receive a byte addressed to it.

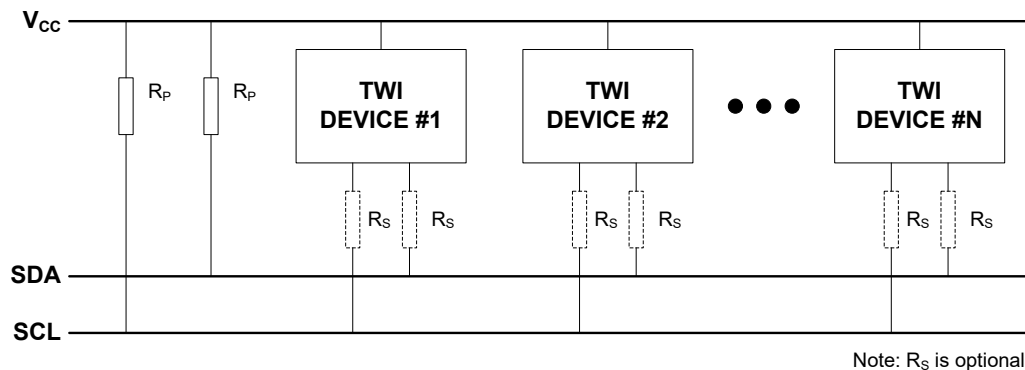
### 26.3.2 General TWI Bus Concepts

The TWI provides a simple, bidirectional, two-wire communication bus consisting of a serial clock line (SCL) and a serial data line (SDA). The two lines are open-collector lines (wired-AND), and pull-up resistors ( $R_p$ ) are the only external components needed to drive the bus. The pull-up resistors provide a high level on the lines when none of the connected devices are driving the bus.

The TWI bus is a simple and efficient method of interconnecting multiple devices on a serial bus. A device connected to the bus can be a master or slave, where the master controls the bus and all communication.

Figure 26-2 illustrates the TWI bus topology.

**Figure 26-2. TWI Bus Topology**



A unique address is assigned to all slave devices connected to the bus, and the master will use this to address a slave and initiate a data transaction.

Several masters can be connected to the same bus, called a multi-master environment. An arbitration mechanism is provided for resolving bus ownership among masters, since only one master device may own the bus at any given time.

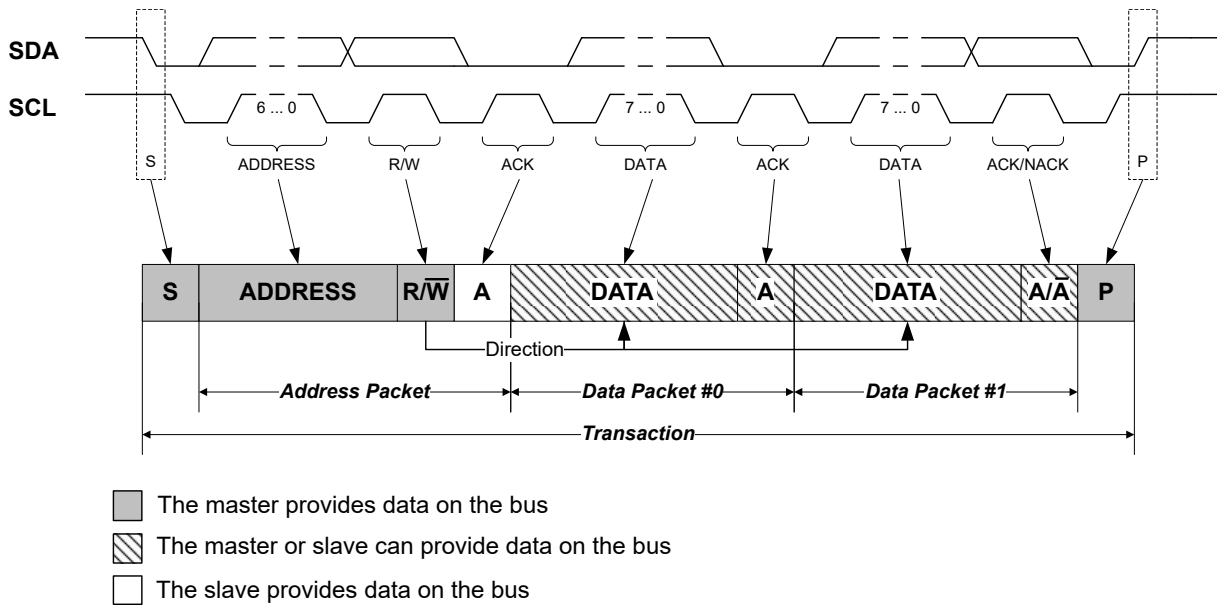
A device can contain both master and slave logic and can emulate multiple slave devices by responding to more than one address.

A master indicates the start of a transaction by issuing a Start condition (S) on the bus. An address packet with a slave address (ADDRESS) and an indication whether the master wishes to read or write data ( $R/\bar{W}$ ) are then sent. After all data packets (DATA) are transferred, the master issues a Stop condition (P) on the bus to end the transaction. The receiver must acknowledge (A) or not-acknowledge ( $\bar{A}$ ) each byte received.

Figure 26-3 shows a TWI transaction.



**Figure 26-3. Basic TWI Transaction Diagram Topology for a 7-Bit Address Bus**

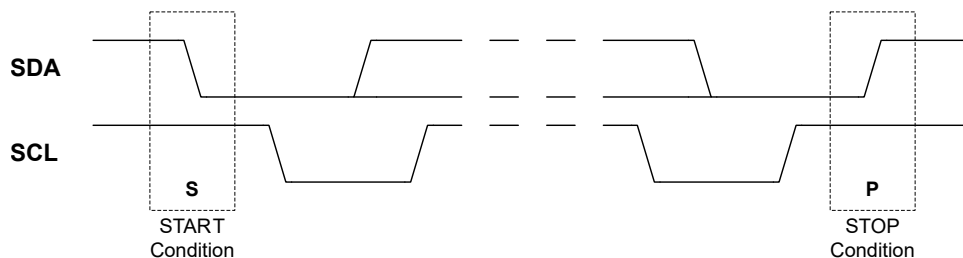


The master provides the clock signal for the transaction, but a device connected to the bus is allowed to stretch the low-level period of the clock to decrease the clock speed.

### 26.3.2.1 Start and Stop Conditions

Two unique bus conditions are used for marking the beginning (Start) and end (Stop) of a transaction. The master issues a Start condition (S) by indicating a high-to-low transition on the SDA line while the SCL line is kept high. The master completes the transaction by issuing a Stop condition (P), indicated by a low-to-high transition on the SDA line while the SCL line is kept high.

**Figure 26-4. Start and Stop Conditions**

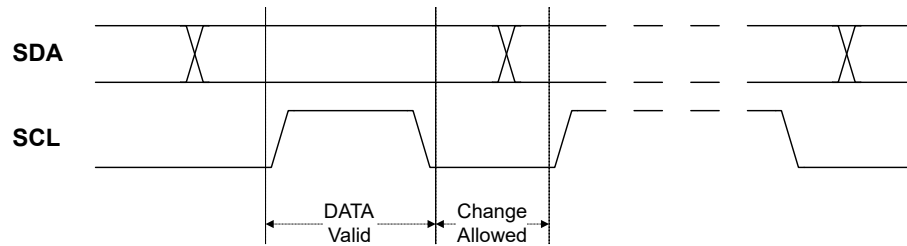


Multiple Start conditions can be issued during a single transaction. A Start condition that is not directly following a Stop condition is called a repeated Start condition (Sr).

### 26.3.2.2 Bit Transfer

As illustrated in [Figure 26-5](#), a bit transferred on the SDA line must be stable for the entire high period of the SCL line. Consequently, the SDA value can only be changed during the low period of the clock. This is ensured in hardware by the TWI module.

**Figure 26-5. Data Validity**



Combining bit transfers result in the formation of address and data packets. These packets consist of eight data bits (one byte) with the Most Significant bit transferred first, plus a single-bit not-Acknowledge (NACK) or Acknowledge (ACK) response. The addressed device signals ACK by pulling the SCL line low during the ninth clock cycle, and signals NACK by leaving the line SCL high.

### 26.3.2.3 Address Packet

After the Start condition, a 7-bit address followed by a read/write ( $R/\bar{W}$ ) bit is sent. This is always transmitted by the master. A slave recognizing its address will ACK the address by pulling the data line low for the next SCL cycle, while all other slaves should keep the TWI lines released and wait for the next Start and address. The address,  $R/\bar{W}$  bit, and Acknowledge bit combined is the address packet. Only one address packet for each Start condition is allowed, also when 10-bit addressing is used.

The  $R/\bar{W}$  bit specifies the direction of the transaction. If the  $R/\bar{W}$  bit is low, it indicates a master write transaction, and the master will transmit its data after the slave has acknowledged its address. If the  $R/\bar{W}$  bit is high, it indicates a master read transaction, and the slave will transmit its data after acknowledging its address.

### 26.3.2.4 Data Packet

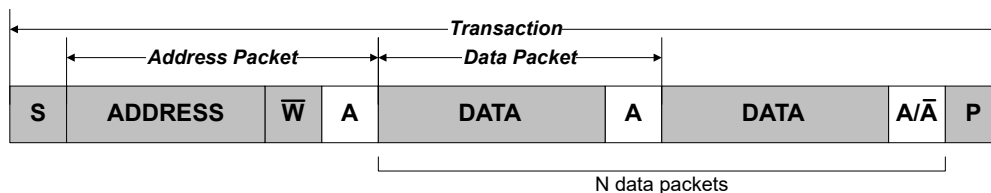
An address packet is followed by one or more data packets. All data packets are nine bits long, consisting of one data byte and one Acknowledge bit. The direction bit in the previous address packet determines the direction in which the data is transferred.

### 26.3.2.5 Transaction

A transaction is the complete transfer from a Start to a Stop condition, including any repeated Start conditions in between. The TWI standard defines three fundamental transaction modes: Master write, master read, and a combined transaction.

Figure 26-6 illustrates the master write transaction. The master initiates the transaction by issuing a Start condition (S) followed by an address packet with the direction bit set to '0' ( $ADDRESS+\bar{W}$ ).

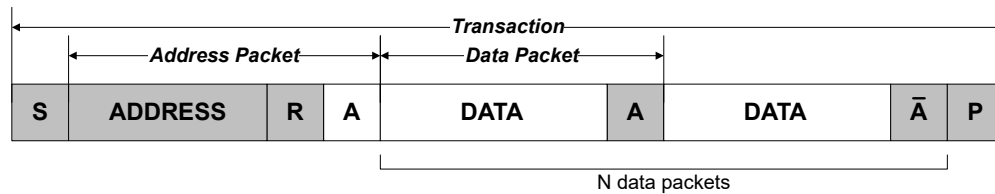
**Figure 26-6. Master Write Transaction**



Assuming the slave acknowledges the address, the master can start transmitting data (DATA) and the slave will ACK or NACK ( $A/\bar{A}$ ) each byte. If no data packets are to be transmitted, the master terminates the transaction by issuing a Stop condition (P) directly after the address packet. There are no limitations to the number of data packets that can be transferred. If the slave signals a NACK to the data, the master must assume that the slave cannot receive any more data and terminate the transaction.

Figure 26-7 illustrates the master read transaction. The master initiates the transaction by issuing a Start condition followed by an address packet with the direction bit set to '1' (ADDRESS+R). The addressed slave must acknowledge the address for the master to be allowed to continue the transaction.

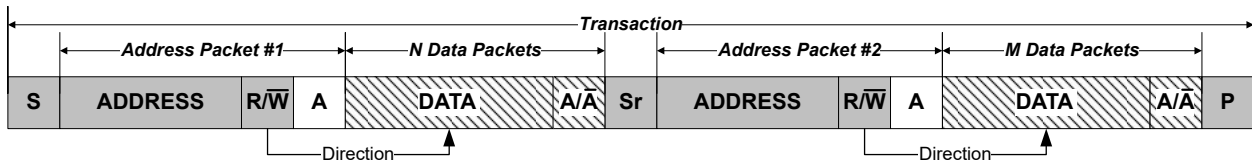
**Figure 26-7. Master Read Transaction**



Assuming the slave acknowledges the address, the master can start receiving data from the slave. There are no limitations to the number of data packets that can be transferred. The slave transmits the data while the master signals ACK or NACK after each data byte. The master terminates the transfer with a NACK before issuing a Stop condition.

Figure 26-8 illustrates a combined transaction. A combined transaction consists of several read and write transactions separated by repeated Start conditions (Sr).

**Figure 26-8. Combined Transaction**

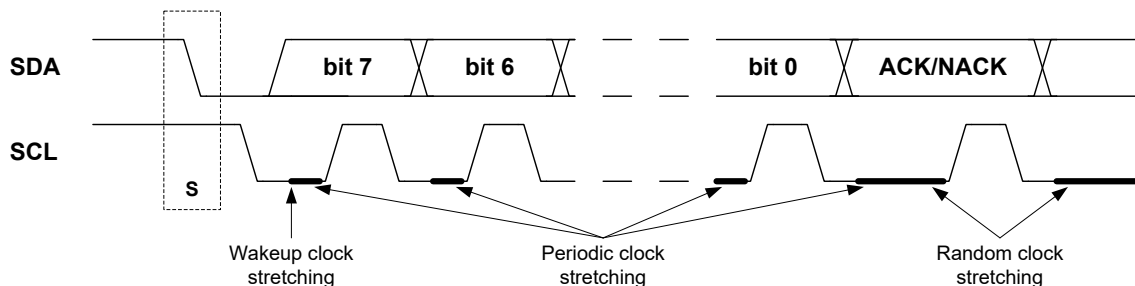


### 26.3.2.6 Clock and Clock Stretching

All devices connected to the bus are allowed to stretch the low period of the clock to slow down the overall clock frequency or to insert Wait states while processing data. A device that needs to stretch the clock can do this by holding/forcing the SCL line low after it detects a low level on the line.

Three types of clock stretching can be defined, as shown in Figure 26-9.

**Figure 26-9. Clock Stretching <sup>(1)</sup>**



**Note:** Clock stretching is not supported by all I<sup>2</sup>C slaves and masters.

If a slave device is in Sleep mode and a Start condition is detected, the clock stretching normally works during the wake-up period. For AVR devices, the clock stretching will be either directly before or after the ACK/NACK bit, as AVR devices do not need to wake-up for transactions that are not addressed to it.

A slave device can slow down the bus frequency by stretching the clock periodically on a bit level. This allows the slave to run at a lower system clock frequency. However, the overall performance of the bus will be reduced accordingly. Both the master and slave device can randomly stretch the clock on a byte level basis before and after the ACK/NACK bit. This provides time to process incoming or prepare outgoing data or perform other time-critical tasks.

In the case where the slave is stretching the clock, the master will be forced into a Wait state until the slave is ready, and vice versa.

### 26.3.2.7 Arbitration

A master can start a bus transaction only if it has detected that the bus is idle. As the TWI bus is a multi-master bus, it is possible that two devices may initiate a transaction at the same time. This results in multiple masters owning the bus simultaneously. This is solved using an arbitration scheme where the master loses control of the bus if it is not able to transmit a high level on the SDA line. The masters who lose arbitration must then wait until the bus becomes idle (i.e., wait for a Stop condition) before attempting to reacquire bus ownership. Slave devices are not involved in the arbitration procedure.

**Figure 26-10. TWI Arbitration**

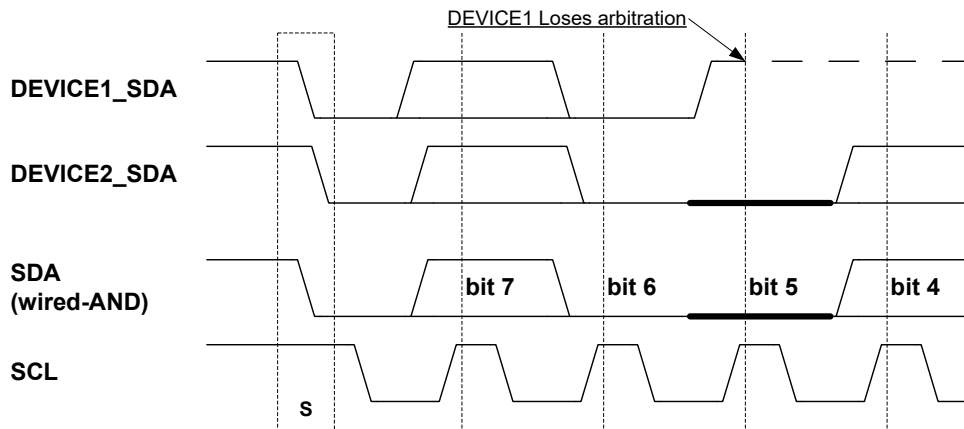


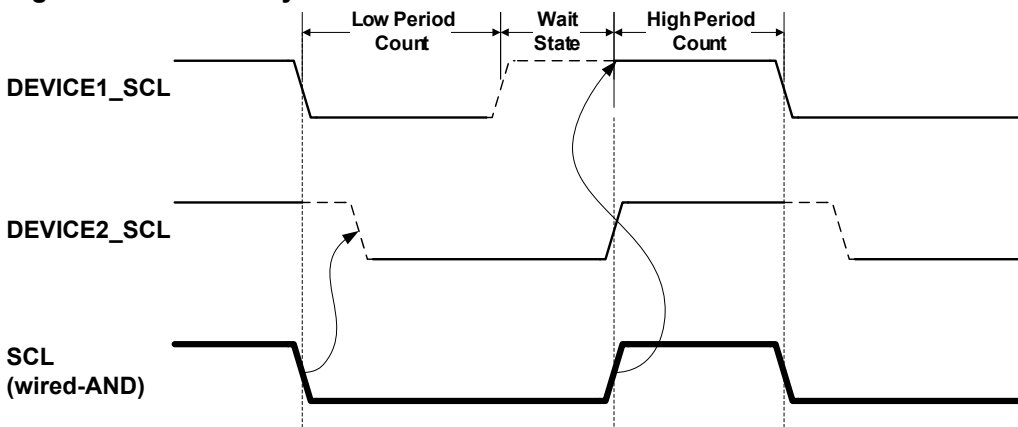
Figure 26-10 shows an example where two TWI masters are contending for bus ownership. Both devices are able to issue a Start condition, but DEVICE1 loses arbitration when attempting to transmit a high level (bit 5) while DEVICE2 is transmitting a low level.

Arbitration between a repeated start condition and a data bit, a Stop condition and a data bit, or a repeated Start condition and a Stop condition are not allowed and will require special handling by software.

### 26.3.2.8 Synchronization

A clock synchronization algorithm is necessary for solving situations where more than one master is trying to control the SCL line at the same time. The algorithm is based on the same principles used for the clock stretching previously described. Figure 26-11 shows an example where two masters are competing for control over the bus clock. The SCL line is the wired-AND result of the two masters clock outputs.

**Figure 26-11. Clock Synchronization**



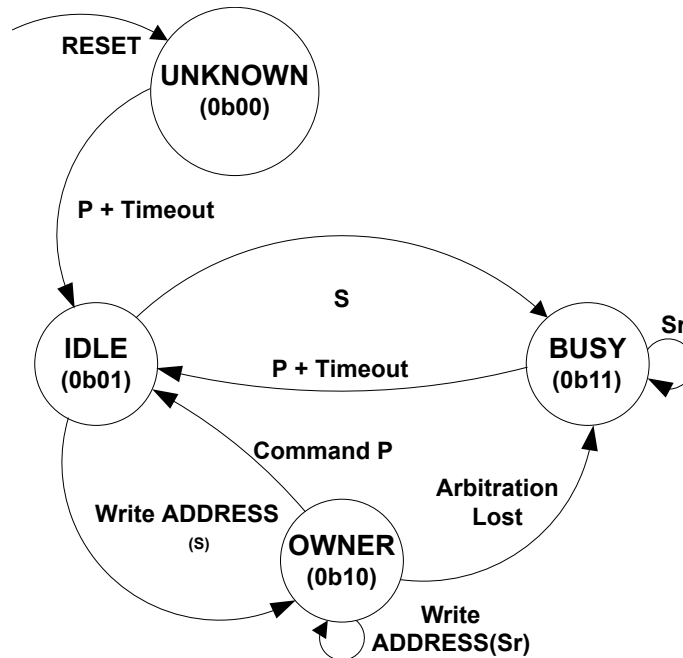
A high-to-low transition on the SCL line will force the line low for all masters on the bus, and they will start timing their low clock period. The timing length of the low clock period can vary among the masters. When a master (DEVICE1 in this case) has completed its low period, it releases the SCL line. However, the SCL line will not go high until all masters have released it. Consequently, the SCL line will be held low by the device with the longest low period (DEVICE2). Devices with shorter low periods must insert a wait state until the clock is released. All masters start their high period when the SCL line is released by all devices and has gone high. The device, which first completes its high period (DEVICE1), forces the clock line low, and the procedure is then repeated. The result is that the device with the shortest clock period determines the high period, while the low period of the clock is determined by the device with the longest clock period.

### 26.3.3 TWI Bus State Logic

The bus state logic continuously monitors the activity on the TWI bus lines when the master is enabled. It continues to operate in all Sleep modes, including power-down.

The bus state logic includes Start and Stop condition detectors, collision detection, inactive bus time-out detection, and a bit counter. These are used to determine the bus state. The software can get the current bus state by reading the Bus State bits in the master STATUS register. The bus state can be unknown, idle, busy, or owner, and is determined according to the state diagram shown in [Figure 26-12](#). The values of the Bus State bits according to state, are shown in binary in the figure below.

**Figure 26-12. Bus State, State Diagram**



After a system Reset and/or TWI master enable, the bus state is unknown. The bus state machine can be forced to enter idle state by writing to the Bus State bits accordingly. If no state is set by the application software, the bus state will become idle when the first Stop condition is detected. If the master inactive bus time-out is enabled, the bus state will change to idle on the occurrence of a time-out. After a known bus state is established, only a system Reset or disabling of the TWI master will set the state to unknown.

When the bus is idle, it is ready for a new transaction. If a Start condition generated externally is detected, the bus becomes busy until a Stop condition is detected. The Stop condition will change the bus state to idle. If the master inactive bus time-out is enabled, the bus state will change from busy to idle on the occurrence of a time-out.

If a Start condition is generated internally while in an Idle state, the owner state is entered. If the complete transaction was performed without interference (i.e., no collisions are detected), the master will issue a Stop condition and the bus state will change back to idle. If a collision is detected, the arbitration is assumed lost and the bus state becomes busy until a Stop condition is detected. A repeated Start condition will only change the bus state if arbitration is lost during the issuing of the repeated Start. Arbitration during repeated Start can be lost only if the arbitration has been ongoing since the first Start condition. This happens if two masters send the exact same ADDRESS+DATA before one of the masters' issues a repeated Start (Sr).

## 26.3.4 Operation

### 26.3.4.1 Electrical Characteristics

The TWI module in AVR devices follows the electrical specifications and timing of I<sup>2</sup>C bus and SMBus. These specifications are not 100% compliant, and so to ensure correct behavior, the inactive bus time-out period should be set in TWI Master mode. Refer to [26.3.4.2 TWI Master Operation](#) for more details.

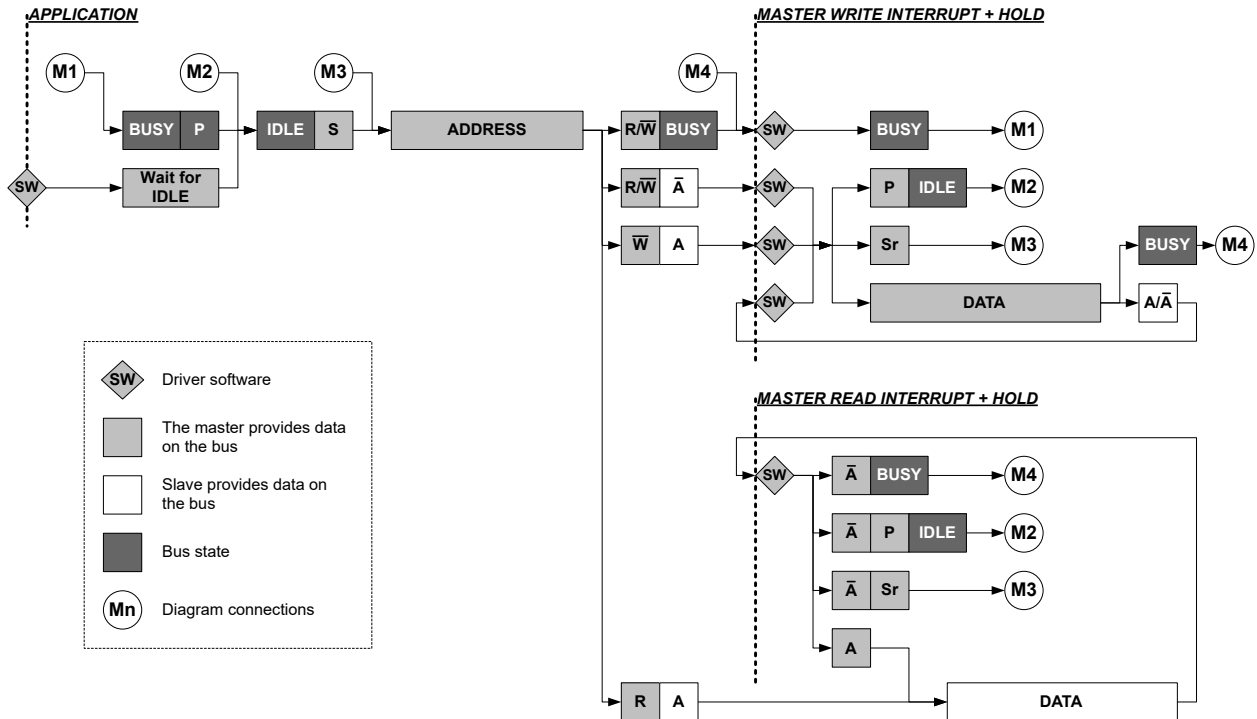
### 26.3.4.2 TWI Master Operation

The TWI master is byte-oriented, with an optional interrupt after each byte. There are separate interrupt flags for master write and master read. Interrupt flags can also be used for a polled operation. There are

dedicated status flags for indicating ACK/NACK received, bus error, arbitration lost, clock hold, and bus state.

When an interrupt flag is set, the SCL line is forced low. This will give the master time to respond or handle any data, and will in most cases require software interaction. [Figure 26-13](#) shows the TWI master operation. The diamond-shaped symbols (SW) indicate where software interaction is required. Clearing the interrupt flags releases the SCL line.

**Figure 26-13. TWI Master Operation**



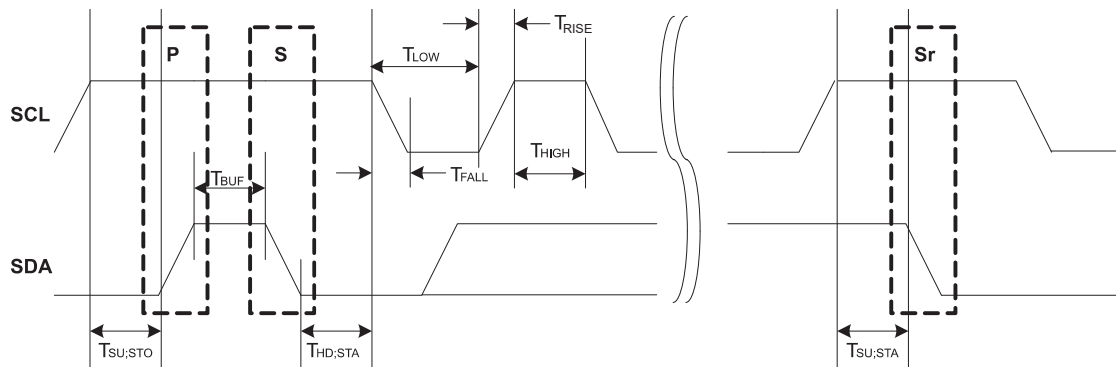
The number of interrupts generated is kept to a minimum by an automatic handling of most conditions.

### 26.3.4.2.1 Clock Generation

The BAUD must be set to a value that results in a TWI bus clock frequency ( $f_{SCL}$ ) equal or less than 100 kHz/400 kHz/1 MHz, dependent on the mode used by the application (Standard mode Sm/Fast mode Fm/Fast mode plus Fm+).

The low ( $T_{LOW}$ ) and high ( $T_{HIGH}$ ) times are determined by the Baud Rate register (BAUD), while the rise ( $T_{RISE}$ ) and fall ( $T_{FALL}$ ) times are determined by the bus topology. Because of the wired-AND logic of the bus,  $T_{FALL}$  will be considered as part of  $T_{LOW}$ . Likewise,  $T_{RISE}$  will be in a state between  $T_{LOW}$  and  $T_{HIGH}$  until a high state has been detected.

**Figure 26-14. SCL Timing**



- $T_{LOW}$  – Low period of SCL clock
- $T_{SU;STO}$  – Setup time for Stop condition
- $T_{BUF}$  – Bus free time between Stop and Start conditions
- $T_{HD;STA}$  – Hold time (repeated) Start condition
- $T_{SU;STA}$  – Setup time for repeated Start condition
- $T_{HIGH}$  is timed using the SCL high time count from TWI.MBAUD
- $T_{RISE}$  is determined by the bus impedance; for internal pull-ups. Refer to *Electrical Characteristics*.
- $T_{FALL}$  is determined by the open-drain current limit and bus impedance; can typically be regarded as zero. Refer to *Electrical Characteristics* for details.

The SCL frequency is given by:

$$f_{SCL} = \frac{1}{T_{LOW} + T_{HIGH} + T_{RISE}}$$

The TWI.MBAUD value is used to time both SCL high and SCL low which gives the following formula of SCL frequency:

$$f_{SCL} = \frac{f_{CLK\_PER}}{10 + 2BAUD + f_{CLK\_PER} \cdot T_{RISE}}$$

If the TWI is in Fm+ mode, only TWI.MBAUD value of three or higher is supported. This means that for Fm+ mode to achieve baud rate of 1 MHz, the peripheral clock (CLK\_PER) has to run at 16 MHz or faster.

### 26.3.4.2.2 Transmitting Address Packets

After issuing a Start condition, the master starts performing a bus transaction when the Master Address register is written with the 7-bit slave address and direction bit. If the bus is busy, the TWI master will wait until the bus becomes idle before issuing the Start condition.

Depending on arbitration and the  $R/\overline{W}$  direction bit, one of four distinct cases (M1 to M4) arises following the address packet. The different cases must be handled in software.

#### **Case M1: Arbitration Lost or Bus Error during Address Packet**

If arbitration is lost during the sending of the address packet, both the Master Write Interrupt Flag (WIF in TWIn.MSTATUS) and Arbitration Lost Flag (ARBLOST in TWIn.MSTATUS) are set. Serial data output to the SDA line is disabled, and the SCL line is released. The master is no longer allowed to perform any operation on the bus until the bus state has changed back to idle.



A bus error will behave in the same way as an arbitration lost condition, but the Bus Error Flag (BUSERR in TWIn.MSTATUS) is set in addition to the write interrupt and arbitration lost flags.

**Case M2: Address Packet Transmit Complete - Address not Acknowledged by Slave**

If no slave device responds to the address, the Master Write Interrupt Flag (WIF in TWIn.MSTATUS) and the Master Received Acknowledge Flag (RXACK in TWIn.MSTATUS) are set. The RXACK flag reflects the physical state of the ACK bit (i.e. < no slave did pull the ACK bit low). The clock hold is active at this point, preventing further activity on the bus.

**Case M3: Address Packet Transmit Complete - Direction Bit Cleared**

If the master receives an ACK from the slave, the Master Write Interrupt Flag (WIF in TWIn.MSTATUS) is set and the Master Received Acknowledge Flag (RXACK in TWIn.MSTATUS) is cleared. The clock hold is active at this point, preventing further activity on the bus.

**Case M4: Address Packet Transmit Complete - Direction Bit Set**

If the master receives an ACK from the slave, the master proceeds to receive the next byte of data from the slave. When the first data byte is received, the Master Read Interrupt Flag (RIF in TWIn.MSTATUS) is set and the Master Received Acknowledge Flag (RXACK in TWIn.MSTATUS) is cleared. The clock hold is active at this point, preventing further activity on the bus.

### 26.3.4.2.3 Transmitting Data Packets

The slave will know when an address packet with  $R/\overline{W}$  direction bit set has been successfully received. It can then start sending data by writing to the slave data register. When a data packet transmission is completed, the data interrupt flag is set. If the master indicates NACK, the slave must stop transmitting data and expect a Stop or repeated Start condition.

### 26.3.4.2.4 Receiving Data Packets

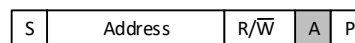
The slave will know when an address packet with  $R/\overline{W}$  direction bit cleared has been successfully received. After acknowledging this, the slave must be ready to receive data. When a data packet is received, the data interrupt flag is set and the slave must indicate ACK or NACK. After indicating a NACK, the slave must expect a Stop or repeated Start condition.

### 26.3.4.2.5 Quick Command Mode

With Quick Command enabled (QCEN in TWIn.MCTRLA), the  $R/W\#$  bit of the slave address denotes the command. This is a SMBus specific command where the  $R/\overline{W}$  bit may be used to simply turn a device function ON or OFF, or enable/disable a low-power Standby mode. There is no data sent or received.

After the master receives an acknowledge from the slave, either RIF or WIF flag in TWIn.MSTATUS will be set depending on the polarity of  $R/\overline{W}$ . When either RIF or WIF flag is set after issuing a Quick Command, the TWI will accept a stop command through writing the CMD bits in TWIn.MCTRLB.

**Figure 26-15. Quick Command Frame Format**

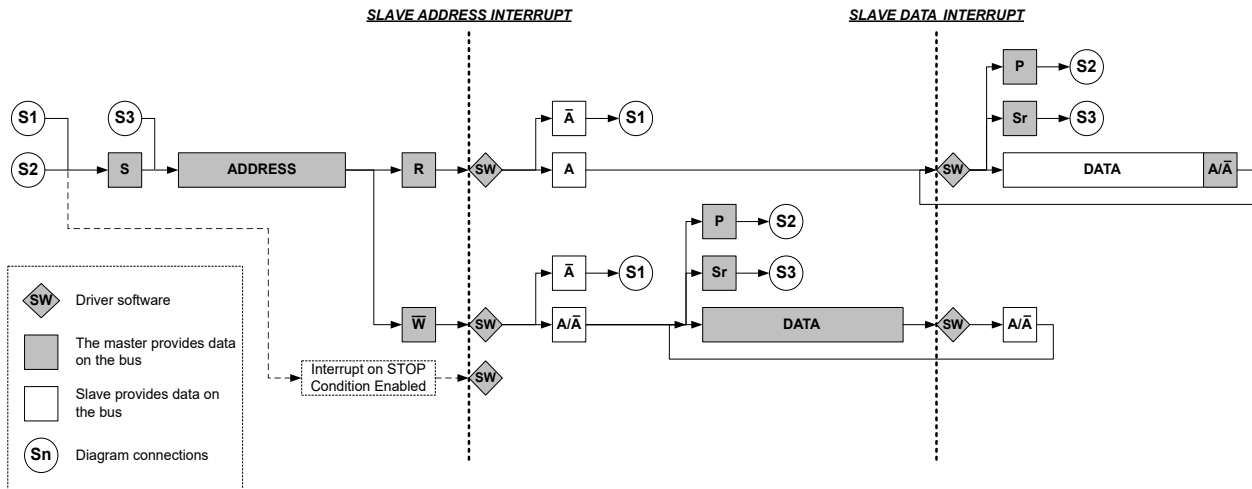


### 26.3.4.3 TWI Slave Operation

The TWI slave is byte-oriented with optional interrupts after each byte. There are separate slave data and address/stop interrupt flags. Interrupt flags can also be used for polled operation. There are dedicated status flags for indicating ACK/NACK received, clock hold, collision, bus error, and read/write direction.

When an interrupt flag is set, the SCL line is forced low. This will give the slave time to respond or handle data, and will in most cases require software interaction. [Figure 26-16](#) shows the TWI slave operation. The diamond-shaped symbols (SW) indicate where software interaction is required.

**Figure 26-16. TWI Slave Operation**



The number of interrupts generated is kept to a minimum by automatic handling of most conditions. Quick command can be enabled to auto-trigger operations and reduce software complexity.

Address Recognition mode can be enabled to allow the slave to respond to all received addresses.

### 26.3.4.3.1 Receiving Address Packets

When the TWI slave is properly configured, it will wait for a Start condition to be detected. When this happens, the successive address byte will be received and checked by the address match logic, and the slave will ACK a correct address and store the address in the TWIn.DATA register. If the received address is not a match, the slave will not acknowledge and store the address, but wait for a new Start condition.

The slave address/stop interrupt flag is set when a Start condition succeeded by a valid address byte is detected. A general call address will also set the interrupt flag.

A Start condition immediately followed by a Stop condition is an illegal operation and the bus error flag is set.

The  $R/\bar{W}$  direction flag reflects the direction bit received with the address. This can be read by software to determine the type of operation currently in progress.

Depending on the  $R/\bar{W}$  direction bit and bus condition, one of four distinct cases (S1 to S4) arises following the address packet. The different cases must be handled in software.

#### **Case S1: Address Packet Accepted - Direction Bit Set**

If the  $R/\bar{W}$  direction flag is set, this indicates a master read operation. The SCL line is forced low by the slave, stretching the bus clock. If ACK is sent by the slave, the slave hardware will set the data interrupt flag indicating data is needed for transmit. Data, repeated Start, or Stop can be received after this. If NACK is sent by the slave, the slave will wait for a new Start condition and address match.

#### **Case S2: Address Packet Accepted - Direction Bit Cleared**

If the  $R/\bar{W}$  direction flag is cleared, this indicates a master write operation. The SCL line is forced low, stretching the bus clock. If ACK is sent by the slave, the slave will wait for data to be received. Data, repeated Start, or Stop can be received after this. If NACK is sent, the slave will wait for a new Start condition and address match.

#### **Case S3: Collision**

If the slave is not able to send a high level or NACK, the collision flag is set, and it will disable the data and acknowledge output from the slave logic. The clock hold is released. A Start or repeated Start condition will be accepted.

### **Case S4: STOP Condition Received**

When the Stop condition is received, the slave address/stop flag will be set, indicating that a Stop condition, and not an address match, occurred.

#### **26.3.4.3.2 Receiving Data Packets**

The slave will know when an address packet with  $R/\bar{W}$  direction bit cleared has been successfully received. After acknowledging this, the slave must be ready to receive data. When a data packet is received, the data interrupt flag is set and the slave must indicate ACK or NACK. After indicating a NACK, the slave must expect a Stop or repeated Start condition.

#### **26.3.4.3.3 Transmitting Data Packets**

The slave will know when an address packet with  $R/\bar{W}$  direction bit set has been successfully received. It can then start sending data by writing to the slave data register. When a data packet transmission is completed, the data interrupt flag is set. If the master indicates NACK, the slave must stop transmitting data and expect a Stop or repeated Start condition.

#### **26.3.4.4 Smart Mode**

The TWI interface has a Smart mode that simplifies application code and minimizes the user interaction needed to adhere to the I<sup>2</sup>C protocol. For TWI Master, Smart mode accomplishes this by automatically sending an ACK as soon as data register TWI.MDATA is read. This feature is only active when the ACKACT bit in TWIn.MCTRLA register is set to ACK. If ACKACT is set to NACK, the TWI Master will not generate a NACK bit followed by reading the Data register.

With Smart mode enabled for TWI Slave (SMEN bit in TWIn.SCTRLA), DIF (Data Interrupt Flag) will automatically be cleared if Data register (TWIn.SDATA) is read or written.

#### **26.3.5 Events**

Not applicable.

#### **26.3.6 Interrupts**

**Table 26-2. Available Interrupt Vectors and Sources**

Offset	Name	Vector Description	Conditions
0x00	Slave	TWI Slave interrupt	<ul style="list-style-type: none"> <li>DIF: Data Interrupt Flag in <a href="#">26.5.11 SSTATUS</a> set</li> <li>APIF: Address or Stop Interrupt Flag in <a href="#">26.5.11 SSTATUS</a> set</li> </ul>
0x02	Master	TWI Master interrupt	<ul style="list-style-type: none"> <li>RIF: Read Interrupt Flag in <a href="#">26.5.5 MSTATUS</a> set</li> <li>WIF: Write Interrupt Flag in <a href="#">26.5.5 MSTATUS</a> set</li> </ul>

When an interrupt condition occurs, the corresponding interrupt flag is set in the Master register (TWI.MSTATUS) or Slave Status register (TWI.SSTATUS).

When several interrupt request conditions are supported by an interrupt vector, the interrupt requests are ORed together into one combined interrupt request to the interrupt controller. The user must read the peripheral's INTFLAGS register to determine which of the interrupt conditions are present.

#### **Related Links**

- [13. CPUINT - CPU Interrupt Controller](#)
- [8.7.3 SREG](#)

### 26.3.7 Sleep Mode Operation

The bus state logic and slave continue to operate in all Sleep modes, including Power-Down Sleep mode. If a slave device is in Sleep mode and a Start condition is detected, clock stretching is active during the wake-up period until the system clock is available. The master will stop operation in all Sleep modes.

### 26.3.8 Synchronization

Not applicable.

### 26.3.9 Configuration Change Protection

Not applicable.

### 26.4 Register Summary - TWI

Offset	Name	Bit Pos.									
0x00	<a href="#">CTRLA</a>	7:0				SDASETUP	SDAHOLD[1:0]		FMPEN		
0x01	Reserved										
0x02	<a href="#">DBGCTRL</a>	7:0								DBGRUN	
0x03	<a href="#">MCTRLA</a>	7:0	RIEN	WIEN		QCEN	TIMEOUT[1:0]		SMEN	ENABLE	
0x04	<a href="#">MCTRLB</a>	7:0					FLUSH	ACKACT	MCMD[1:0]		
0x05	<a href="#">MSTATUS</a>	7:0	RIF	WIF	CLKHOLD	RXACK	ARBLOST	BUSERR	BUSSTATE[1:0]		
0x06	<a href="#">MBAUD</a>	7:0	BAUD[7:0]								
0x07	<a href="#">MADDR</a>	7:0	ADDR[7:0]								
0x08	<a href="#">MDATA</a>	7:0	DATA[7:0]								
0x09	<a href="#">SCTRLA</a>	7:0	DIEN	APIEN	PIEN			PMEN	SMEN	ENABLE	
0x0A	<a href="#">SCTRLB</a>	7:0						ACKACT	SCMD[1:0]		
0x0B	<a href="#">SSTATUS</a>	7:0	DIF	APIF	CLKHOLD	RXACK	COLL	BUSERR	DIR	AP	
0x0C	<a href="#">SADDR</a>	7:0	ADDR[7:0]								
0x0D	<a href="#">SDATA</a>	7:0	DATA[7:0]								
0x0E	<a href="#">SADDRMASK</a>	7:0	ADDRMASK[6:0]								ADDREN

### 26.5 Register Description

### 26.5.1 Control A

**Name:** CTRLA  
**Offset:** 0x00  
**Reset:** 0x00  
**Property:** -

	Bit	7	6	5	4	3	2	1	0
					SDASETUP	SDAHOLD[1:0]		FMPEN	
Access					R/W	R/W	R/W	R/W	
Reset					0	0	0	0	

#### Bit 4 – SDASETUP SDA Setup Time

By default, there are four clock cycles of setup time on SDA out signal while reading from the slave part of the TWI module. Writing this bit to '1' will change the setup time to eight clocks.

Value	Name	Description
0	4CYC	SDA setup time is four clock cycles
1	8CYC	SDA setup time is eight clock cycle

#### Bits 3:2 – SDAHOLD[1:0] SDA Hold Time

Writing these bits selects the SDA hold time.

**Table 26-3. SDA Hold Time**

SDAHOLD[1:0]	Nominal Hold Time	Hold Time Range Across All Corners in ns	Description
0x0	OFF	0	Hold time OFF.
0x1	50 ns	36 - 131	Backward compatible setting.
0x2	300 ns	180 - 630	Meets SMBus specification under typical conditions.
0x3	500 ns	300 - 1050	Meets SMBus specification across all corners.

#### Bit 1 – FMPEN FM Plus Enable

Writing these bits selects the 1 MHz bus speed (Fast mode plus, Fm+) for the TWI in default configuration.

Value	Description
0	Fm+ disabled
1	Fm+ enabled

### 26.5.2 Debug Control

**Name:**       DBGCTRL  
**Offset:**     0x02  
**Reset:**       0x00  
**Property:**   -

	7	6	5	4	3	2	1	0
								DBGRUN
Access								R/W
Reset								0

#### Bit 0 – DBGRUN   Debug Run

Value	Description
0	The peripheral is halted in Break Debug mode and ignores events
1	The peripheral will continue to run in Break Debug mode when the CPU is halted

### 26.5.3 Master Control A

**Name:** MCTRLA  
**Offset:** 0x03  
**Reset:** 0x00  
**Property:** -

Bit	7	6	5	4	3	2	1	0
	RIEN	WIEN		QCEN	TIMEOUT[1:0]		SMEN	ENABLE
Access	R/W	R/W		R/W	R/W	R/W	R/W	R/W
Reset	0	0		0	0	0	0	0

#### Bit 7 – RIEN Read Interrupt Enable

Writing this bit to '1' enables interrupt on the Master Read Interrupt Flag (RIF) in the Master Status register (TWIn.MSTATUS). A TWI Master read interrupt would be generated only if this bit, the RIF, and the Global Interrupt Flag (I) in CPU.SREG are all '1'.

#### Bit 6 – WIEN Write Interrupt Enable

Writing this bit to '1' enables interrupt on the Master Write Interrupt Flag (WIF) in the Master Status register (TWIn.MSTATUS). A TWI Master write interrupt will be generated only if this bit, the WIF, and the Global Interrupt Flag (I) in CPU.SREG are all '1'.

#### Bit 4 – QCEN Quick Command Enable

Writing this bit to '1' enables Quick Command. When Quick Command is enabled, the corresponding interrupt flag is set immediately after the slave acknowledges the address. At this point, the software can either issue a Stop command or a repeated Start by writing either the Command bits (CMD) in the Master Control B register (TWIn.MCTRLB) or the Master Address register (TWIn.MADDR).

#### Bits 3:2 – TIMEOUT[1:0] Inactive Bus Time-Out

Setting the inactive bus time-out (TIMEOUT) bits to a non-zero value will enable the inactive bus time-out supervisor. If the bus is inactive for longer than the TIMEOUT setting, the bus state logic will enter the Idle state.

Value	Name	Description
0x0	DISABLED	Bus time-out disabled. I <sup>2</sup> C.
0x1	50US	50 $\mu$ s - SMBus (assume baud is set to 100 kHz)
0x2	100US	100 $\mu$ s (assume baud is set to 100 kHz)
0x3	200US	200 $\mu$ s (assume baud is set to 100 kHz)

#### Bit 1 – SMEN Smart Mode Enable

Writing this bit to '1' enables the Master Smart mode. When Smart mode is enabled, the acknowledge action is sent immediately after reading the Master Data (TWIn.MDATA) register.

#### Bit 0 – ENABLE Enable TWI Master

Writing this bit to '1' enables the TWI as master.



### 26.5.4 Master Control B

**Name:** MCTRLB  
**Offset:** 0x04  
**Reset:** 0x00  
**Property:** -

	Bit	7	6	5	4	3	2	1	0
						FLUSH	ACKACT	MCMD[1:0]	
Access						R/W	R/W	R/W	R/W
Reset						0	0	0	0

#### Bit 3 – FLUSH Flush

Writing a '1' to this bit generates a strobe for one clock cycle disabling and then enabling the master.

Writing '0' has no effect.

The purpose is to clear the internal state of the master: For TWI master to transmit successfully, it is recommended to write the Master Address register (TWIn.MADDR) first and then the Master Data register (TWIn.MDATA).

The peripheral will transmit invalid data if TWIn.MDATA is written before TWIn.MADDR. To avoid this invalid transmission, write '1' to this bit to clear both registers.

#### Bit 2 – ACKACT Acknowledge Action

This bit defines the master's behavior under certain conditions defined by the bus protocol state and software interaction. The acknowledge action is performed when DATA is read, or when an execute command is written to the CMD bits.

The ACKACT bit is not a flag or strobe, but an ordinary read/write accessible register bit. The default ACKACT for master read interrupt is "Send ACK" (0). For master write, the code will know that no acknowledge should be sent since it is itself sending data.

Value	Description
0	Send ACK
1	Send NACK

#### Bits 1:0 – MCMD[1:0] Command

The master command bits are strobes. These bits are always read as zero.

Writing to these bits triggers a master operation as defined by the table below.

**Table 26-4. Command Settings**

MCMD[1:0]	DIR	Description
0x0	X	NOACT - No action
0x1	X	REPSTART - Execute Acknowledge Action succeeded by repeated Start
0x2	0	RECVTRANS - Execute Acknowledge Action succeeded by a byte read operation

MCMD[1:0]	DIR	Description
	1	Execute Acknowledge Action (no action) succeeded by a byte send operation <sup>(1)</sup>
0x3	X	STOP - Execute Acknowledge Action succeeded by issuing a Stop condition

**Note:**

1. For a master being a sender, it will normally wait for new data written to the Master Data register (TWIn.MDATA).

The acknowledge action bits and command bits can be written at the same time.

### 26.5.5 Master Status

**Name:** MSTATUS  
**Offset:** 0x05  
**Reset:** 0x00  
**Property:** -

Normal TWI operation dictates that this register is regarded purely as a read-only register. Clearing any of the status flags is done indirectly by accessing the Master Transmits Address (TWIn.MADDR), the Master Data register (TWIn.MDATA), or the Command bits (CMD) in the Master Control B register (TWIn.MCTRLB).

Bit	7	6	5	4	3	2	1	0
	RIF	WIF	CLKHOLD	RXACK	ARBLOST	BUSERR	BUSSTATE[1:0]	
Access	R/W	R/W	R/W	R	R/W	R/W	R/W	R/W
Reset	0	0	0	0	0	0	0	0

#### Bit 7 – RIF Read Interrupt Flag

This bit is set to '1' when the master byte read operation is successfully completed (i.e., no arbitration lost or bus error occurred during the operation). The read operation is triggered by software reading DATA or writing to ADDR registers with bit ADDR[0] written to '1'. A slave device must have responded with an ACK to the address and direction byte transmitted by the master for this flag to be set.

Writing a '1' to this bit will clear the RIF. However, normal use of the TWI does not require the flag to be cleared by this method.

Clearing the RIF bit will follow the same software interaction as the CLKHOLD flag.

The RIF flag can generate a master read interrupt (see the description of the RIEN control bit in the TWIn.MCTRLA register).

#### Bit 6 – WIF Write Interrupt Flag

This bit is set when a master transmit address or byte write is completed, regardless of the occurrence of a bus error or an arbitration lost condition.

Writing a '1' to this bit will clear the WIF. However, normal use of the TWI does not require the flag to be cleared by this method.

Clearing the WIF bit will follow the same software interaction as the CLKHOLD flag.

The WIF flag can generate a master write interrupt (see the description of the WIEN control bit in the TWIn.MCTRLA register).

#### Bit 5 – CLKHOLD Clock Hold

If read as '1', this bit indicates that the master is currently holding the TWI clock (SCL) low, stretching the TWI clock period.

Writing a '1' to this bit will clear the CLKHOLD flag. However, normal use of the TWI does not require the CLKHOLD flag to be cleared by this method, since the flag is automatically cleared when accessing several other TWI registers. The CLKHOLD flag can be cleared by:

1. Writing a '1' to it.
2. Writing to the TWIn.MADDR register.

3. Writing to the TWIn.MDATA register.
4. Reading the TWIn.DATA register while the ACKACT control bits in TWIn.MCTRLB are set to either send ACK or NACK.
5. Writing a valid command to the TWIn.MCTRLB register.

#### **Bit 4 – RXACK** Received Acknowledge

This bit is read-only and contains the most recently received Acknowledge bit from the slave. When read as '0', the most recent acknowledge bit from the slave was ACK. When read as '1', the most recent acknowledge bit was NACK.

#### **Bit 3 – ARBLOST** Arbitration Lost

If read as '1' this bit indicates that the master has lost arbitration while transmitting a high data or NACK bit, or while issuing a Start or repeated Start condition (S/Sr) on the bus.

Writing a '1' to it will clear the ARBLOST flag. However, normal use of the TWI does not require the flag to be cleared by this method. However, as for the CLKHOLD flag, clearing the ARBLOST flag is not required during normal use of the TWI.

Clearing the ARBLOST bit will follow the same software interaction as the CLKHOLD flag.

Given the condition where the bus ownership is lost to another master, the software must either abort operation or resend the data packet. Either way, the next required software interaction is in both cases to write to the TWIn.MADDR register. A write access to the TWIn.MADDR register will then clear the ARBLOST flag.

#### **Bit 2 – BUSERR** Bus Error

The BUSERR flag indicates that an illegal bus condition has occurred. An illegal bus condition is detected if a protocol violating Start (S), repeated Start (Sr), or Stop (P) is detected on the TWI bus lines. A Start condition directly followed by a Stop condition is one example of protocol violation.

Writing a '1' to this bit will clear the BUSERR. However, normal use of the TWI does not require the BUSERR to be cleared by this method.

A robust TWI driver software design will treat the bus error flag similarly to the ARBLOST flag, assuming the bus ownership is lost when the bus error flag is set. As for the ARBLOST flag, the next software operation of writing the TWIn.MADDR register will consequently clear the BUSERR flag. For bus error to be detected, the bus state logic must be enabled and the system frequency must be 4x the SCL frequency.

#### **Bits 1:0 – BUSSTATE[1:0]** Bus State

These bits indicate the current TWI bus state as defined in the table below. After a System Reset or re-enabling, the TWI master bus state will be unknown. The change of bus state is dependent on the bus activity.

Writing 0x1 to the BUSSTATE bits forces the bus state logic into its Idle state. However, the bus state logic cannot be forced into any other state. When the master is disabled, the bus state is 'unknown'.

Value	Name	Description
0x0	UNKNOWN	Unknown bus state
0x1	IDLE	Bus is idle
0x2	OWNER	This TWI controls the bus
0x3	BUSY	The bus is busy

### 26.5.6 Master Baud Rate

**Name:** MBAUD  
**Offset:** 0x06  
**Reset:** 0x00  
**Property:** -

	7		6		5		4		3		2		1		0
	BAUD[7:0]														
Access	R/W		R/W		R/W		R/W		R/W		R/W		R/W		R/W
Reset	0		0		0		0		0		0		0		0

**Bits 7:0 – BAUD[7:0]** Baud Rate

This bit field is used to derive the SCL high and low time and should be written while the master is disabled (ENABLE bit in TWIn.MCTRLA is '0').

For more information on how to calculate the frequency, see the section on Clock Generation.

### 26.5.7 Master Address

**Name:** MADDR  
**Offset:** 0x07  
**Reset:** 0x00  
**Property:** -

	7		6		5		4		3		2		1		0
	ADDR[7:0]														
Access	R/W		R/W		R/W		R/W		R/W		R/W		R/W		R/W
Reset	0		0		0		0		0		0		0		0

#### Bits 7:0 – ADDR[7:0] Address

When this bit field is written, a Start condition and slave address protocol sequence is initiated dependent on the bus state.

If the bus state is unknown the Master Write Interrupt Flag (WIF) and Bus Error flag (BUSERR) in the Master Status register (TWIn.MSTATUS) are set and the operation is terminated.

If the bus is busy the master awaits further operation until the bus becomes idle. When the bus is or becomes idle, the master generates a Start condition on the bus, copies the ADDR value into the Data Shift register (TWIn.MDATA) and performs a byte transmit operation by sending the contents of the Data register onto the bus. The master then receives the response (i.e., the Acknowledge bit from the slave). After completing the operation the bus clock (SCL) is forced and held low only if arbitration was not lost. The CLKHOLD bit in the Master Setup register (TWIn.MSETUP) is set accordingly. Completing the operation sets the WIF in the Master Status register (TWIn.MSTATUS).

If the bus is already owned, a repeated Start (Sr) sequence is performed. In two ways the repeated Start (Sr) sequence deviates from the Start sequence. Firstly, since the bus is already owned by the master, no wait for idle bus state is necessary. Secondly, if the previous transaction was a read, the acknowledge action is sent before the Repeated Start bus condition is issued on the bus.

The master receives one data byte from the slave before the master sets the Master Read Interrupt Flag (RIF) in the Master Status register (TWIn.MSTATUS). All TWI Master flags are cleared automatically when this bit field is written. This includes bus error, arbitration lost, and both master interrupt flags.

This register can be read at any time without interfering with ongoing bus activity, since a read access does not trigger the master logic to perform any bus protocol related operations.

The master control logic uses bit 0 of the TWIn.MADDR register as the bus protocol's Read/Write flag ( $R/\overline{W}$ ).

**26.5.8 Master DATA**

**Name:** MDATA  
**Offset:** 0x08  
**Reset:** 0x00  
**Property:** -

Bit	7	6	5	4	3	2	1	0
	DATA[7:0]							
Access	R/W	R/W	R/W	R/W	R/W	R/W	R/W	R/W
Reset	0	0	0	0	0	0	0	0

**Bits 7:0 – DATA[7:0] Data**

The bit field gives direct access to the master's physical Shift register which is used both to shift data out onto the bus (write) and to shift in data received from the bus (read).

The direct access implies that the Data register cannot be accessed during byte transmissions. Built-in logic prevents any write access to this register during the shift operations. Reading valid data or writing data to be transmitted can only be successfully done when the bus clock (SCL) is held low by the master (i.e., when the CLKHOLD bit in the Master Status register (TWIn.MSTATUS) is set). However, it is not necessary to check the CLKHOLD bit in software before accessing this register if the software keeps track of the present protocol state by using interrupts or observing the interrupt flags.

Accessing this register assumes that the master clock hold is active, auto-triggers bus operations dependent of the state of the Acknowledge Action Command bit (ACKACT) in TWIn.MSTATUS and type of register access (read or write).

A write access to this register will, independent of ACKACT in TWIn.MSTATUS, command the master to perform a byte transmit operation on the bus directly followed by receiving the Acknowledge bit from the slave. When the Acknowledge bit is received, the Master Write Interrupt Flag (WIF) in TWIn.MSTATUS is set regardless of any bus errors or arbitration. If operating in a multi-master environment, the interrupt handler or application software must check the Arbitration Lost Status Flag (ARBLOST) in TWIn.MSTATUS before continuing from this point. If the arbitration was lost, the application software must decide to either abort or to resend the packet by rewriting this register. The entire operation is performed (i.e., all bits are clocked), regardless of winning or losing arbitration before the write interrupt flag is set. When arbitration is lost, only '1's are transmitted for the remainder of the operation, followed by a write interrupt with ARBLOST flag set.

Both TWI Master Interrupt Flags are cleared automatically when this register is written. However, the Master Arbitration Lost and Bus Error flags are left unchanged.

Reading this register triggers a bus operation, dependent on the setting of the Acknowledge Action Command bit (ACKACT) in TWIn.MSTATUS. Normally the ACKACT bit is preset to either ACK or NACK before the register read operation. If ACK or NACK action is selected, the transmission of the acknowledge bit precedes the release of the clock hold. The clock is released for one byte, allowing the slave to put one byte of data on the bus. The Master Read Interrupt flag RIF in TWIn.MSTATUS is then set if the procedure was successfully executed. However, if arbitration was lost when sending NACK, or a bus error occurred during the time of operation, the Master Write Interrupt flag (WIF) is set instead. Observe that the two Master Interrupt Flags are mutually exclusive (i.e., both flags will not be set simultaneously).

Both TWI Master Interrupt Flags are cleared automatically if this register is read while ACKACT is set to either ACK or NACK. However, arbitration lost and bus error flags are left unchanged.



### 26.5.9 Slave Control A

**Name:** SCTRLA  
**Offset:** 0x09  
**Reset:** 0x00  
**Property:** -

Bit	7	6	5	4	3	2	1	0
	DIEN	APIEN	PIEN			PMEN	SMEN	ENABLE
Access	R/W	R/W	R/W			R/W	R/W	R/W
Reset	0	0	0			0	0	0

#### Bit 7 – DIEN Data Interrupt Enable

Writing this bit to '1' enables interrupt on the Slave Data Interrupt Flag (DIF) in the Slave Status register (TWIn.SSTATUS). A TWI slave data interrupt will be generated only if this bit, the DIF, and the Global Interrupt Flag (I) in CPU.SREG are all '1'.

#### Bit 6 – APIEN Address or Stop Interrupt Enable

Writing this bit to '1' enables an interrupt on the Slave Address or Stop Interrupt Flag (APIF) in the Slave Status register (TWIn.SSTATUS). A TWI slave Address or Stop interrupt will be generated only if this bit, APIF, and the Global Interrupt Flag (I) in CPU.SREG are all '1'.

The slave stop interrupt shares the interrupt flag and vector with the slave address interrupt. The TWIn.SCTRLA.PIEN must be written to '1' in order for the APIF to be set on a stop condition. When the interrupt occurs the TWIn.SSTATUS.AP bit will determine whether an address match or a stop condition caused the interrupt.

#### Bit 5 – PIEN Stop Interrupt Enable

Writing this bit to '1' enables APIF to be set when a Stop condition occurs. To use this feature the system frequency must be 4x the SCL frequency.

#### Bit 2 – PMEN Address Recognition Mode

If this bit is written to '1', the slave address match logic responds to all received addresses.

If this bit is written to '0', the address match logic uses the Slave Address register (TWIn.SADDR) to determine which address to recognize as the slaves own address.

#### Bit 1 – SMEN Smart Mode Enable

Writing this bit to '1' enables the slave Smart mode. When the Smart mode is enabled, issuing a command with CMD or reading/writing DATA resets the interrupt and operation continues. If the Smart mode is disabled, the slave always waits for a CMD command before continuing.

#### Bit 0 – ENABLE Enable TWI Slave

Writing this bit to '1' enables the TWI slave.

### 26.5.10 Slave Control B

**Name:** SCTRLB  
**Offset:** 0x0A  
**Reset:** 0x00  
**Property:** -

	Bit	7	6	5	4	3	2	1	0
							ACKACT	SCMD[1:0]	
Access							R/W	R/W	R/W
Reset							0	0	0

#### Bit 2 – ACKACT Acknowledge Action

This bit defines the slave's behavior under certain conditions defined by the bus protocol state and software interaction. The table below lists the acknowledge procedure performed by the slave if action is initiated by software. The acknowledge action is performed when TWIn.SDATA is read or written, or when an execute command is written to the CMD bits in this register.

The ACKACT bit is not a flag or strobe, but an ordinary read/write accessible register bit.

Value	Name	Description
0	ACK	Send ACK
1	NACK	Send NACK

#### Bits 1:0 – SCMD[1:0] Command

Unlike the acknowledge action bits, the Slave command bits are strobes. These bits always read as '0'. Writing to these bits trigger a slave operation as defined in the table below.

**Table 26-5. Command Settings**

SCMD[1:0]	DIR	Description
0x0	X	NOACT - No action
0x1	X	Reserved
0x2 - COMPTRANS	Used to complete a transaction	
	0	Execute Acknowledge Action succeeded by waiting for any Start (S/Sr) condition
	1	Wait for any Start (S/Sr) condition
0x3 - RESPONSE	Used in response to an address interrupt (APIF)	
	0	Execute Acknowledge Action succeeded by reception of next byte
	1	Execute Acknowledge Action succeeded by slave data interrupt
	Used in response to a data interrupt (DIF)	
	0	Execute Acknowledge Action succeeded by reception of next byte
	1	Execute a byte read operation followed by Acknowledge Action

The acknowledge action bits and command bits can be written at the same time.

### 26.5.11 Slave Status

**Name:** SSTATUS  
**Offset:** 0x0B  
**Reset:** 0x00  
**Property:** -

Normal TWI operation dictates that the Slave Status register should be regarded purely as a read-only register. Clearing any of the status flags will indirectly be done when accessing the Slave Data (TWIn.SDATA) register or the CMD bits in the Slave Control B register (TWIn.SCTRLB).

Bit	7	6	5	4	3	2	1	0
	DIF	APIF	CLKHOLD	RXACK	COLL	BUSERR	DIR	AP
Access	R/W	R/W	R	R	R/W	R/W	R	R
Reset	0	0	0	0	0	0	0	0

#### Bit 7 – DIF Data Interrupt Flag

This flag is set when a slave byte transmit or byte receive operation is successfully completed without any bus error. The flag can be set with an unsuccessful transaction in case of collision detection (see the description of the COLL Status bit). Writing a '1' to its bit location will clear the DIF. However, normal use of the TWI does not require the DIF flag to be cleared by using this method, since the flag is automatically cleared when:

1. Writing to the Slave DATA register.
2. Reading the Slave DATA register.
3. Writing a valid command to the CTRLB register.

The DIF flag can be used to generate a slave data interrupt (see the description of the DIEN control bit in TWIn.CTRLA).

#### Bit 6 – APIF Address or Stop Interrupt Flag

This flag is set when the slave address match logic detects that a valid address has been received or by a Stop condition. Writing a '1' to its bit location will clear the APIF. However, normal use of the TWI does not require the flag to be cleared by this method since the flag is cleared using the same software interactions as described for the DIF flag.

The APIF flag can be used to generate a slave address or stop interrupt (see the description of the AIEN control bit in TWIn.CTRLA). Take special note of that the slave stop interrupt shares the interrupt vector with the slave address interrupt.

#### Bit 5 – CLKHOLD Clock Hold

If read as '1', the slave clock hold flag indicates that the slave is currently holding the TWI clock (SCL) low, stretching the TWI clock period. This is a read-only bit that is set when an address or data interrupt is set. Resetting the corresponding interrupt will indirectly reset this flag.

#### Bit 4 – RXACK Received Acknowledge

This bit is read-only and contains the most recently received Acknowledge bit from the master. When read as '0', the most recent acknowledge bit from the master was ACK. When read as '1', the most recent acknowledge bit was NACK.

### Bit 3 – COLL Collision

If read as '1', the transmit collision flag indicates that the slave has not been able to transmit a high data or NACK bit. If a slave transmit collision is detected, the slave will commence its operation as normal, except no low values will be shifted out onto the SDA line (i.e., when the COLL flag is set to '1' it disables the data and acknowledge output from the slave logic). The DIF flag will be set to '1' at the end as a result of the internal completion of an unsuccessful transaction. Similarly, when a collision occurs because the slave has not been able to transmit NACK bit, it means the address match already happened and APIF flag is set as a result. APIF/DIF flags can only generate interrupts whose handlers can be used to check for the collision. Writing a '1' to its bit location will clear the COLL flag. However, the flag is automatically cleared if any Start condition (S/Sr) is detected.

This flag is intended for systems where the address resolution protocol (ARP) is employed. However, a detected collision in non-ARP situations indicates that there has been a protocol violation and should be treated as a bus error.

### Bit 2 – BUSERR Bus Error

The BUSERR flag indicates that an illegal bus condition has occurred. An illegal bus condition is detected if a protocol violating Start (S), Repeated Start (Sr), or Stop (P) is detected on the TWI bus lines. A Start condition directly followed by a Stop condition is one example of protocol violation. Writing a '1' to its bit location will clear the BUSERR flag. However, normal use of the TWI does not require the BUSERR to be cleared by this method. A robust TWI driver software design will assume that the entire packet of data has been corrupted and restart by waiting for a new Start condition (S). The TWI bus error detector is part of the TWI Master circuitry. For bus errors to be detected, the TWI Master must be enabled (ENABLE bit in TWIn.MCTRLA is '1'), and the system clock frequency must be at least four times the SCL frequency.

### Bit 1 – DIR Read/Write Direction

This bit is read-only and indicates the current bus direction state. The DIR bit reflects the direction bit value from the last address packet received from a master TWI device. If this bit is read as '1', a master read operation is in progress. Consequently, a '0' indicates that a master write operation is in progress.

### Bit 0 – AP Address or Stop

When the TWI slave address or Stop Interrupt Flag (APIF) is set, this bit determines whether the interrupt is due to address detection or a Stop condition.

Value	Name	Description
0	STOP	A Stop condition generated the interrupt on APIF
1	ADR	Address detection generated the interrupt on APIF

### 26.5.12 Slave Address

**Name:** SADDR  
**Offset:** 0x0C  
**Reset:** 0x00  
**Property:** -

Bit	7	6	5	4	3	2	1	0
	ADDR[7:0]							
Access	R/W	R/W	R/W	R/W	R/W	R/W	R/W	R/W
Reset	0	0	0	0	0	0	0	0

#### Bits 7:0 – ADDR[7:0] Address

The Slave Address register in combination with the Slave Address Mask register (TWIn.SADDRMASK) is used by the slave address match logic to determine if a master TWI device has addressed the TWI slave. The Slave Address Interrupt Flag (APIF) is set to '1' if the received address is recognized. The slave address match logic supports recognition of 7- and 10-bits addresses, and general call address.

When using 7-bit or 10-bit Address Recognition mode, the upper seven bits of the Address register (ADDR[7:1]) represent the slave address and the Least Significant bit (ADDR[0]) is used for general call address recognition. Writing the ADDR[0] bit to '1', in this case, enables the general call address recognition logic. The TWI slave address match logic only supports recognition of the first byte of a 10-bit address (i.e., by setting ADDR[7:1] = "0b11110aa" where "aa" represents bit 9 and 8, or the slave address). The second 10-bit address byte must be handled by software.

### 26.5.13 Slave Data

**Name:** SDATA  
**Offset:** 0x0D  
**Reset:** 0x00  
**Property:** -

	7		6		5		4		3		2		1		0
	DATA[7:0]														
Access	R/W		R/W		R/W		R/W		R/W		R/W		R/W		R/W
Reset	0		0		0		0		0		0		0		0

#### Bits 7:0 – DATA[7:0] Data

The Slave Data register I/O location (DATA) provides direct access to the slave's physical Shift register, which is used both to shift data out onto the bus (transmit) and to shift in data received from the bus (receive). The direct access implies that the Data register cannot be accessed during byte transmissions. Built-in logic prevents any write accesses to the Data register during the shift operations. Reading valid data or writing data to be transmitted can only be successfully done when the bus clock (SCL) is held low by the slave (i.e., when the slave CLKHOLD bit is set). However, it is not necessary to check the CLKHOLD bit in software before accessing the slave DATA register if the software keeps track of the present protocol state by using interrupts or observing the interrupt flags. Accessing the slave DATA register, assumed that clock hold is active, auto-trigger bus operations dependent of the state of the Slave Acknowledge Action Command bits (ACKACT) and type of register access (read or write).

### 26.5.14 Slave Address Mask

**Name:** SADDRMASK  
**Offset:** 0x0E  
**Reset:** 0x00  
**Property:** -

Bit	7	6	5	4	3	2	1	0
	ADDRMASK[6:0]							ADDREN
Access	R/W	R/W	R/W	R/W	R/W	R/W	R/W	R/W
Reset	0	0	0	0	0	0	0	0

#### Bits 7:1 – ADDRMASK[6:0] Address Mask

The ADDRMASK register acts as a second address match register, or an address mask register depending on the ADDREN setting.

If ADDREN is written to '0', ADDRMASK can be loaded with a 7-bit Slave Address mask. Each of the bits in the TWIn.SADDRMASK register can mask (disable) the corresponding address bits in the TWI slave Address Register (TWIn.SADDR). If the mask bit is written to '1' then the address match logic ignores the compare between the incoming address bit and the corresponding bit in slave TWIn.SADDR register. In other words, masked bits will always match.

If ADDREN is written to '1', the TWIn.SADDRMASK can be loaded with a second slave address in addition to the TWIn.SADDR register. In this mode, the slave will match on two unique addresses, one in TWIn.SADDR and the other in TWIn.SADDRMASK.

#### Bit 0 – ADDREN Address Mask Enable

If this bit is written to '1', the slave address match logic responds to the two unique addresses in slave TWIn.SADDR and TWIn.SADDRMASK.

If this bit is '0', the TWIn.SADDRMASK register acts as a mask to the TWIn.SADDR register.



## 27. CRCSCAN - Cyclic Redundancy Check Memory Scan

### 27.1 Features

- CRC-16-CCITT
- Can Check Full Flash, Application Code, and/or Boot Section
- Priority Check Mode
- Selectable NMI Trigger on Failure
- User Configurable Check During Internal Reset Initialization
- Paused in all CPU Sleep Modes

### 27.2 Overview

A Cyclic Redundancy Check (CRC) takes a data stream of bytes from the NVM (either entire Flash, only Boot section, or both application code and Boot section) and generates a checksum. The CRC peripheral (CRCSCAN) can be used to detect errors in program memory.

The last location in the section to check has to contain the correct pre-calculated checksum for comparison. If the checksum calculated by the CRCSCAN and the pre-calculated checksums match, a Status bit in the CRCSCAN is set. If they do not match, the Status register will indicate that it failed. The user can choose to let the CRCSCAN generate a Non-Maskable Interrupt (NMI) if the checksums do not match.

An  $n$ -bit CRC, applied to a data block of arbitrary length, will detect any single alteration (error burst) up to  $n$  bits in length. For longer error bursts, a fraction  $1-2^{-n}$  will be detected.

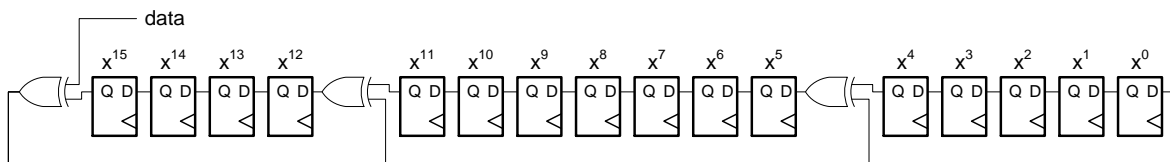
The CRC-generator supports CRC-16-CCITT.

Polynomial:

- CRC-16-CCITT:  $x^{16} + x^{12} + x^5 + 1$

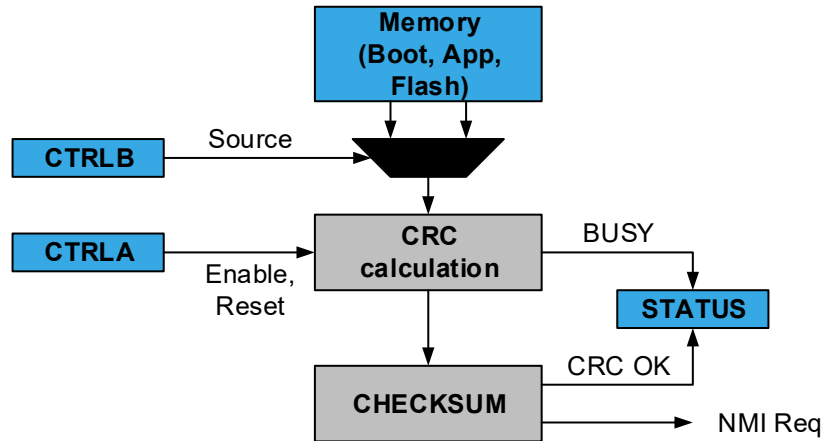
The CRC reads in byte-by-byte of the content of the section(s) it is set up to check, starting with byte 0, and generates a new checksum per byte. The byte is sent through an implementation corresponding to [Figure 27-1](#), starting with the Most Significant bit. If the last two bytes in the section contain the correct checksum, the CRC will pass. See [27.3.2.1 Checksum](#) for how to place the checksum. The initial value of the Checksum register is 0xFFFF.

**Figure 27-1. CRC Implementation Description**



### 27.2.1 Block Diagram

Figure 27-2. Cyclic Redundancy Check Block Diagram



### 27.2.2 System Dependencies

In order to use this peripheral, other parts of the system must be configured correctly, as described below.

Table 27-1. System Product Dependencies

Dependency	Applicable	Peripheral
Clocks	Yes	CLKCTRL
I/O Lines and Connections	No	-
Interrupts	Yes	CPUINT
Events	No	-
Debug	Yes	UPDI

#### Related Links

[11.2.2.1 Clocks](#)

[27.2.2.3 Interrupts](#)

#### 27.2.2.1 Clocks

This peripheral depends on the peripheral clock.

#### Related Links

[10. CLKCTRL - Clock Controller](#)

#### 27.2.2.2 I/O Lines and Connections

Not applicable.

#### 27.2.2.3 Interrupts

Using the interrupts of this peripheral requires the interrupt controller to be configured first.

#### Related Links

[13. CPUINT - CPU Interrupt Controller](#)

[8.7.3 SREG](#)

[27.3.3 Interrupts](#)

### 27.2.2.4 Events

Not applicable.

### 27.2.2.5 Debug Operation

Whenever the debugger accesses the device, for instance, reading or writing a peripheral or memory location, the CRCSCAN peripheral will be disabled.

If the CRCSCAN is busy when the debugger accesses the device, the CRCSCAN will restart the ongoing operation when the debugger accesses an internal register or when the debugger disconnects.

The BUSY bit in the Status register (CRCSCAN.STATUS) will read '1' if the CRCSCAN was busy when the debugger caused it to disable, but it will not actively check any section as long as the debugger keeps it disabled. There are synchronized CRC Status bits in the debugger's internal register space, which can be read by the debugger without disabling the CRCSCAN. Reading the debugger's internal CRC status bits will make sure that the CRCSCAN is enabled.

It is possible to write the CRCSCAN.STATUS register directly from the debugger:

- BUSY bit in CRCSCAN.STATUS:
  - Writing the BUSY bit to '0' will stop the ongoing CRC operation (so that the CRCSCAN does not restart its operation when the debugger allows it).
  - Writing the BUSY bit to '1' will make the CRC start a single check with the settings in the Control B register (CRCSCAN.CTRLB), but not until the debugger allows it.

As long as the BUSY bit in CRCSCAN.STATUS is '1', CRCSCAN.CRCTRLB and the Non-Maskable Interrupt Enable bit (NMIEN) in the Control A register (CRCSCAN.CTRLA) cannot be altered.

- OK bit in CRCSCAN.STATUS:
  - Writing the OK bit to '0' can trigger a Non-Maskable Interrupt (NMI) if the NMIEN bit in CRCSCAN.CTRLA is '1'. If an NMI has been triggered, no writes to the CRCSCAN are allowed.
  - Writing the OK bit to '1' will make the OK bit read as '1' when the BUSY bit in CRCSCAN.STATUS is '0'.

Writes to CRCSCAN.CTRLA and CRCSCAN.CTRLB from the debugger are treated in the same way as writes from the CPU.

#### Related Links

[33. UPDI - Unified Program and Debug Interface](#)

[27.5.1 CTRLA](#)

[27.5.2 CTRLB](#)

## 27.3 Functional Description

### 27.3.1 Initialization

To enable a CRC in software (or via the debugger):

1. Write the Source (SRC) bit field of the Control B register (CRCSCAN.CTRLB) to select the desired source settings. Ensure that the MODE bit field in CRCSCAN.CTRLB is 0x0.
2. Enable the CRCSCAN by writing a '1' to the ENABLE bit in the Control A register (CRCSCAN.CTRLA).
3. The CRC will start after three cycles, and the CPU will continue executing during these three cycles.

The CRCSAN can be enabled during the internal Reset initialization to ensure the Flash is OK before letting the CPU execute code. If the CRCSAN fails during the internal Reset initialization, the CPU is not allowed to start normal code execution - the device remains in Reset state instead of executing code with unexpected behavior. The full source settings are available during the internal Reset initialization. See the Fuse description for more information.

If the CRCSAN was enabled during the internal Reset initialization, the CRC Control A and B registers will reflect this when normal code execution is started:

- The ENABLE bit in CRCSAN.CTRLA will be '1'
- The MODE bit field in CRCSAN.CTRLB will be non-zero
- The SRC bit field in CRCSAN.CTRLB will reflect the checked section(s).

The CRCSAN can be enabled during Reset by configuring the CRCSRC fuse in FUSE.SYSCFG0.

### Related Links

[27.5.1 CTRLA](#)

[27.5.2 CTRLB](#)

[6.10 Configuration and User Fuses \(FUSE\)](#)

[12.3.2.2 Reset Time](#)

### 27.3.2 Operation

The CRC is operating in Priority mode: the CRC peripheral has priority access to the Flash and will stall the CPU until completed.

In Priority mode, the CRC fetches a new word (16-bit) on every third main clock cycle, or when the CRC peripheral is configured to do a scan from start-up.

#### 27.3.2.1 Checksum

The pre-calculated checksum must be present in the last location of the section to be checked. If the BOOT section should be checked, the 16-bit checksum must be saved in the last two bytes of the BOOT section, and similarly for APPLICATION and entire Flash. [Table 27-2](#) shows explicitly how the checksum should be stored for the different sections. Also, see the CRCSAN.CTRLB register description for how to configure which section to check and the device fuse description for how to configure the BOOTEND and APPEND fuses.

**Table 27-2. How to Place the Pre-Calculated 16-Bit Checksum in Flash**

Section to Check	CHECKSUM[15:8]	CHECKSUM[7:0]
BOOT	FUSE_BOOTEND*256-2	FUSE_BOOTEND*256-1
BOOT and APPLICATION	FUSE_APPEND*256-2	FUSE_APPEND*256-1
Full Flash	FLASHEND-1	FLASHEND

### 27.3.3 Interrupts

**Table 27-3. Available Interrupt Vectors and Sources**

Offset	Name	Vector Description	Conditions
0x00	NMI	Non-Maskable Interrupt	Generated on CRC failure

When the interrupt condition occurs, the OK flag in the Status register (CRCSAN.STATUS) is cleared to '0'.

An interrupt is enabled by writing a '1' to the respective Enable bit (NMIEN) in the Control A register (CRCSCAN.CTRLA), but can only be disabled with a system Reset. An NMI is generated when the OK flag in CRCSCAN.STATUS is cleared and the NMIEN bit is '1'. The NMI request remains active until a system Reset, and cannot be disabled.

A non-maskable interrupt can be triggered even if interrupts are not globally enabled.

**Related Links**[27.5.1 CTRLA](#)[27.5.3 STATUS](#)[13. CPUINT - CPU Interrupt Controller](#)**27.3.4 Sleep Mode Operation**

CTCSCAN is halted in all sleep modes. In all CPU Sleep modes, the CRCSCAN peripheral is halted and will resume operation when the CPU wakes up.

The CRCSCAN starts operation three cycles after writing the EN bit in CRCSCAN.CTRLA. During these three cycles, it is possible to enter Sleep mode. In this case:

1. The CRCSCAN will not start until the CPU is woken up.
2. Any interrupt handler will execute after CRCSCAN has finished.

**27.3.5 Configuration Change Protection**

Not applicable.

### 27.4 Register Summary - CRCSCAN

Offset	Name	Bit Pos.								
0x00	<a href="#">CTRLA</a>	7:0	RESET						NMIEN	ENABLE
0x01	<a href="#">CTRLB</a>	7:0							SRC[1:0]	
0x02	<a href="#">STATUS</a>	7:0							OK	BUSY

### 27.5 Register Description

### 27.5.1 Control A

**Name:** CTRLA  
**Offset:** 0x00  
**Reset:** 0x00  
**Property:** -

If an NMI has been triggered, this register is not writable.

Bit	7	6	5	4	3	2	1	0
	RESET						NMIEN	ENABLE
Access	R/W						R/W	R/W
Reset	0						0	0

#### Bit 7 – RESET Reset CRCSCAN

Writing this bit to '1' resets the CRCSCAN peripheral: The CRCSCAN Control registers and STATUS register (CTRLA, CTRLB, STATUS) will be cleared one clock cycle after the RESET bit was written to '1'.

If NMIEN is '0', this bit is writable both when the CRCSCAN is busy (the BUSY bit in CRCSCAN.STATUS is '1') and not busy (the BUSY bit is '0'), and will take effect immediately.

If NMIEN is '1', this bit is only writable when the CRCSCAN is not busy (the BUSY bit in CRCSCAN.STATUS is '0').

The RESET bit is a strobe bit.

#### Bit 1 – NMIEN Enable NMI Trigger

When this bit is written to '1', any CRC failure will trigger an NMI.

This can only be cleared by a system Reset - it is not cleared by a write to the RESET bit.

This bit can only be written to '1' when the CRCSCAN is not busy (the BUSY bit in CRCSCAN.STATUS is '0').

#### Bit 0 – ENABLE Enable CRCSCAN

Writing this bit to '1' enables the CRCSCAN peripheral with the current settings. It will stay '1' even after a CRC check has completed, but writing it to '1' again will start a new check.

Writing the bit to '0' will disable the CRCSCAN after the ongoing check is completed (after reaching the end of the section it is set up to check). A failure in the ongoing check will still be detected and can cause an NMI if the NMIEN bit is '1'.

The CRCSCAN can be enabled during the internal Reset initialization to verify Flash sections before letting the CPU start normal code execution (see the device data sheet fuse description). If the CRCSCAN is enabled during the internal Reset initialization, the ENABLE bit will read as '1' when normal code execution starts.

To see whether the CRCSCAN peripheral is busy with an ongoing check, poll the Busy bit (BUSY) in the STATUS register (CRCSCAN.STATUS).

#### Related Links

[6.10 Configuration and User Fuses \(FUSE\)](#)

[12.3.2.2 Reset Time](#)

### 27.5.2 Control B

**Name:** CTRLB  
**Offset:** 0x01  
**Reset:** 0x00  
**Property:** -

The CTRLB register contains the mode and source settings for the CRC. It is not writable when the CRC is busy or when an NMI has been triggered.

Bit	7	6	5	4	3	2	1	0
							SRC[1:0]	
Access							R/W	R/W
Reset							0	0

#### Bits 1:0 – SRC[1:0] CRC Source

The SRC bit field selects which section of the Flash the CRC module should check. To set up section sizes, refer to the fuse description.

The CRC can be enabled during internal Reset initialization to verify Flash sections before letting the CPU start (see fuse description). If the CRC is enabled during internal Reset initialization, the SRC bit field will read out as FLASH, BOOTAPP, or BOOT when normal code execution starts (depending on the configuration).

Value	Name	Description
0x0	FLASH	The CRC is performed on the entire Flash (boot, application code, and application data sections).
0x1	BOOTAPP	The CRC is performed on the boot and application code sections of Flash.
0x2	BOOT	The CRC is performed on the boot section of Flash.
0x3	-	Reserved.

#### Related Links

[6.10 Configuration and User Fuses \(FUSE\)](#)

[12.3.2.2 Reset Time](#)



### 27.5.3 Status

**Name:** STATUS  
**Offset:** 0x02  
**Reset:** 0x02  
**Property:** -

The STATUS register contains the busy and OK information. It is not writable, only readable.

Bit	7	6	5	4	3	2	1	0
							OK	BUSY
Access							R	R
Reset							1	0

#### Bit 1 – OK CRC OK

When this bit is read as '1', the previous CRC completed successfully. The bit is set to '1' from Reset but is cleared to '0' when enabling. As long as the CRC module is busy, it will be read '0'. When running continuously, the CRC status must be assumed OK until it fails or is stopped by the user.

#### Bit 0 – BUSY CRC Busy

When this bit is read as '1', the CRC module is busy. As long as the module is busy, the access to the control registers is limited.

## 28. CCL - Configurable Custom Logic

### 28.1 Features

- Glue Logic for General Purpose PCB Design
- Up to two Programmable Look-Up Tables LUT[1:0]
- Combinatorial Logic Functions: Any Logic Expression That is a Function of up to Three Inputs.
- Sequential Logic Functions:  
Gated D Flip-Flop, JK Flip-Flop, gated D Latch, RS Latch
- Flexible Look-Up Table Inputs Selection:
  - I/Os
  - Events
  - Subsequent LUT output
  - Internal peripherals
    - Analog comparator
    - Timer/counters
    - USART
    - SPI
- Clocked by System Clock or Other Peripherals
- Output Can be Connected to I/O pins or Event System
- Optional Synchronizer, Filter, or Edge Detector Available on Each LUT Output

### 28.2 Overview

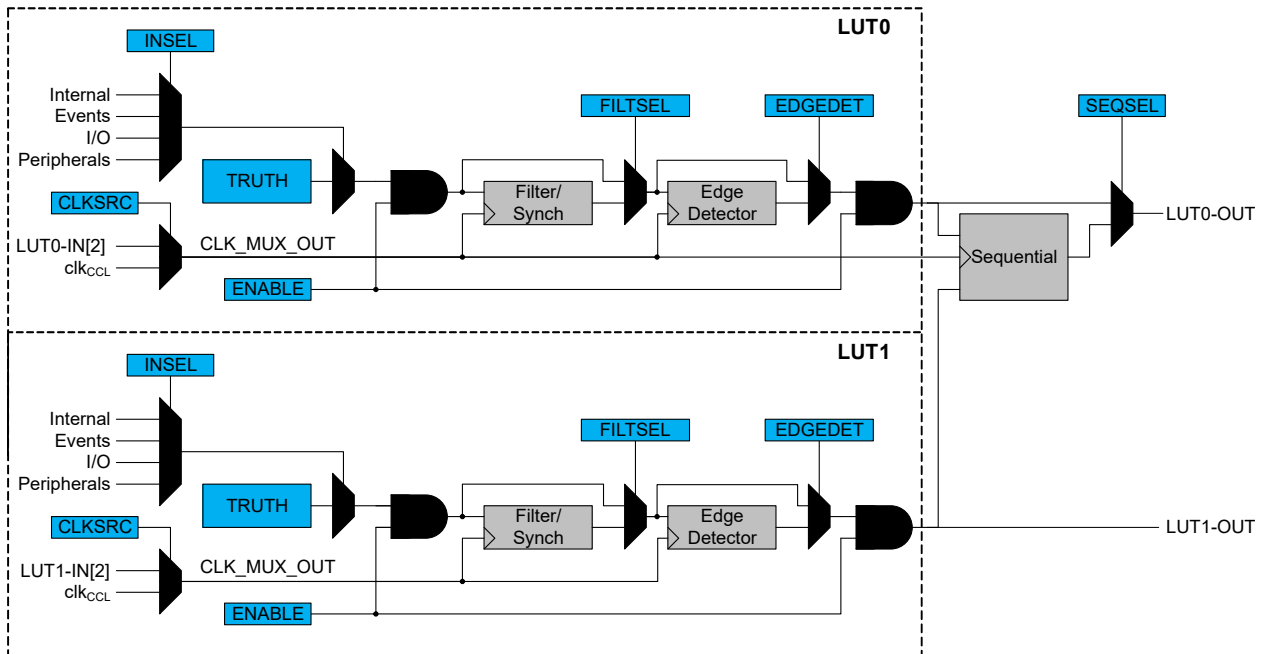
The Configurable Custom Logic (CCL) is a programmable logic peripheral which can be connected to the device pins, to events, or to other internal peripherals. The CCL can serve as "glue logic" between the device peripherals and external devices. The CCL can eliminate the need for external logic components, and can also help the designer to overcome real-time constraints by combining core independent peripherals to handle the most time-critical parts of the application independent of the CPU.

The CCL peripheral has one pair of Look-Up Tables (LUT). Each LUT consists of three inputs, a truth table, and a filter/edge detector. Each LUT can generate an output as a user programmable logic expression with three inputs. Inputs can be individually masked.

The output can be generated from the inputs combinatorially and can be filtered to remove spikes. An optional sequential module can be enabled. The inputs to the sequential module are individually controlled by two independent, adjacent LUT (LUT0/LUT1) outputs, enabling complex waveform generation.

### 28.2.1 Block Diagram

Figure 28-1. Configurable Custom Logic



### 28.2.2 Signal Description

Pin Name	Type	Description
LUTn-OUT	Digital output	Output from look-up table
LUTn-IN[2:0]	Digital input	Input to look-up table

Refer to *I/O Multiplexing and Considerations* for details on the pin mapping for this peripheral. One signal can be mapped to several pins.

#### Related Links

[5. I/O Multiplexing and Considerations](#)

### 28.2.3 System Dependencies

In order to use this peripheral, other parts of the system must be configured correctly, as described below.

Table 28-1. CCL System Dependencies

Dependency	Applicable	Peripheral
Clocks	Yes	CLKCTRL
I/O Lines and Connections	Yes	PORT
Interrupts	Yes	CPUINT
Events	Yes	EVSYS
Debug	Yes	UPDI

### 28.2.3.1 Clocks

By default, the CCL is using the peripheral clock of the device (CLK\_PER).

Alternatively, the CCL can be clocked by a peripheral input that is available on LUT n input line 2 (LUTn\_IN[2]). This is configured by writing a '1' to the Clock Source Selection bit (CLKSRC) in the LUT n Control A register (CCL.LUTnCTRLA). The sequential block is clocked by the same clock as that of the even LUT in the LUT pair (SEQn.clk = LUT2n.clk). It is advised to disable the peripheral by writing a '0' to the Enable bit (ENABLE) in the Control A register (CCL.CTRLA) before configuring the CLKSRC bit in CCL.LUTnCTRLA.

Alternatively, the input line 2 (IN[2]) of an LUT can be used to clock the LUT and the corresponding Sequential block. This is enabled by writing a '1' to the Clock Source Selection bit (CLKSRC) in the LUT n Control A register (CCL.LUTnCTRLA).

The CCL must be disabled before changing the LUT clock source: write a '0' to the Enable bit (ENABLE) in Control A register (CCL.CTRLA).

#### Related Links

[10. CLKCTRL - Clock Controller](#)

### 28.2.3.2 I/O Lines

The CCL can take inputs and generate output through I/O pins. For this to function properly, the I/O pins must be configured to be used by a Look Up Table (LUT).

#### Related Links

[16. PORT - I/O Pin Configuration](#)

### 28.2.3.3 Interrupts

Using the interrupts of this peripheral requires the interrupt controller to be configured first.

### 28.2.3.4 Debug Operation

When the CPU is halted in Debug mode the CCL continues normal operation. However, the CCL cannot be halted when the CPU is halted in Debug mode. If the CCL is configured in a way that requires it to be periodically serviced by the CPU, improper operation or data loss may result during debugging.

## 28.3 Functional Description

### 28.3.1 Initialization

The following bits are enable-protected, meaning that they can only be written when the corresponding even LUT is disabled (ENABLE=0 in CCL.LUT0CTRLA):

- Sequential Selection (SEQSEL) in Sequential Control 0 register (CCL.SEQCTRL0)

The following registers are enable-protected, meaning that they can only be written when the corresponding LUT is disabled (ENABLE=0 in CCL.LUT0CTRLA):

- LUT n Control x register, except ENABLE bit (CCL.LUTnCTRLx)

Enable-protected bits in the CCL.LUTnCTRLx registers can be written at the same time as ENABLE in CCL.LUTnCTRLx is written to '1', but not at the same time as ENABLE is written to '0'.

Enable-protection is denoted by the enable-protected property in the register description.

### 28.3.2 Operation

#### 28.3.2.1 Enabling, Disabling, and Resetting

The CCL is enabled by writing a '1' to the ENABLE bit in the Control register (CCL.CTRLA). The CCL is disabled by writing a '0' to that ENABLE bit.

Each LUT is enabled by writing a '1' to the LUT Enable bit (ENABLE) in the LUT n Control A register (CCL.LUTnCTRLA). Each LUT is disabled by writing a '0' to the ENABLE bit in CCL.LUTnCTRLA.

#### 28.3.2.2 Look-Up Table Logic

The look-up table in each LUT unit can generate a combinational logic output as a function of up to three inputs IN[2:0]. Unused inputs can be masked (tied low). The truth table for the combinational logic expression is defined by the bits in the CCL.TRUTHn registers. Each combination of the input bits (IN[2:0]) corresponds to one bit in the TRUTHn register, as shown in the table below.

**Table 28-2. Truth Table of LUT**

IN[2]	IN[1]	IN[0]	OUT
0	0	0	TRUTH[0]
0	0	1	TRUTH[1]
0	1	0	TRUTH[2]
0	1	1	TRUTH[3]
1	0	0	TRUTH[4]
1	0	1	TRUTH[5]
1	1	0	TRUTH[6]
1	1	1	TRUTH[7]

#### 28.3.2.3 Truth Table Inputs Selection

##### Input Overview

The inputs can be individually:

- Masked
- Driven by Peripherals:
  - Analog Comparator (AC) output
  - Timer/Counters (TC) waveform outputs
- Driven by Internal Events from Event System
- Driven by Other CCL Sub-modules

The input selection for each input y of LUT n is configured by writing the input y source selection bit in the LUT n Control x=[B,C] registers:

- INSEL0 in CCL.LUTnCTRLB
- INSEL1 in CCL.LUTnCTRLB
- INSEL2 in CCL.LUTnCTRLC

##### Internal Feedback Inputs (FEEDBACK)

When selected (INSELY=FEEDBACK in CCL.LUTnCTRLx), the Sequential (SEQ) output is used as input for the corresponding LUT.

The output from an internal sequential module can be used as input source for the LUT, see the figure below for an example for LUT0 and LUT1. The sequential selection for each LUT follows the formula:

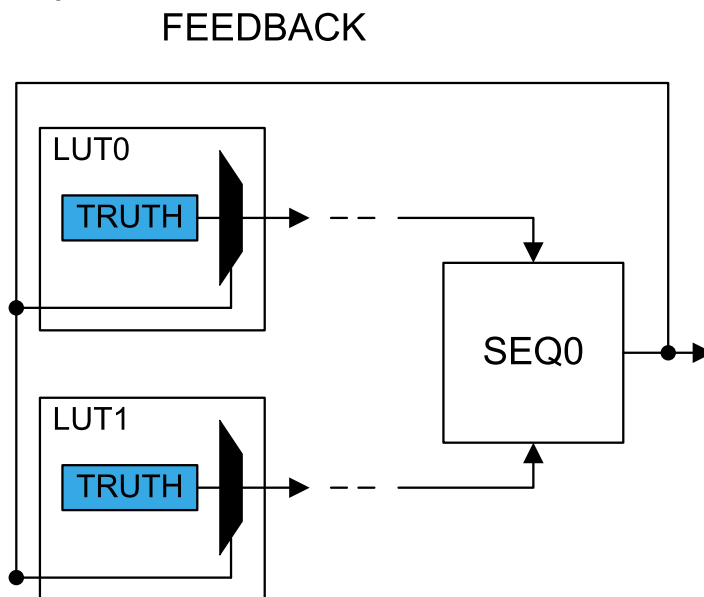
$$IN[2N][i] = SEQ[N]$$

$$IN[2N+1][i] = SEQ[N]$$

With  $N$  representing the sequencer number and  $i=0,1$  representing the LUT input index.

For details, refer to [28.3.2.6 Sequential Logic](#).

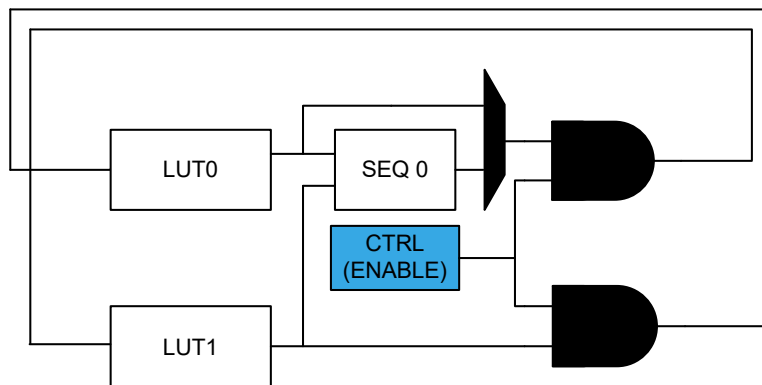
**Figure 28-2. Feedback Input Selection**



### Linked LUT (LINK)

When selecting the LINK input option, the next LUT's direct output is used as the LUT input. In general, LUT[n+1] is linked to the input of LUT[n]. As example, LUT1 is the input for LUT0.

**Figure 28-3. Linked LUT Input Selection**



### Internal Events Inputs Selection (EVENT)

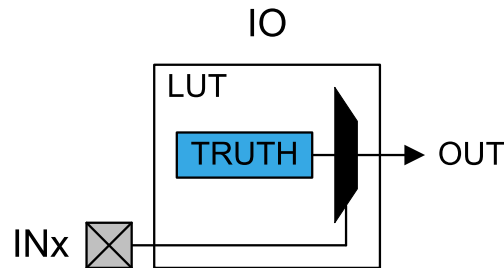
Asynchronous events from the Event System can be used as input to the LUT. Two event input lines (EVENT0 and EVENT1) are available, and can be selected as LUT input. Before selecting the EVENT

input option by writing to the LUT CONTROL A or B register (CCL.LUTnCTRLB or LUTnCTRLC), the Event System must be configured.

### I/O Pin Inputs (I/O)

When selecting the I/O option, the LUT input will be connected to its corresponding I/O pin. Refer to the I/O Multiplexing section for more details about where the LUTnINy is located.

**Figure 28-4. I/O Pin Input Selection**



### Peripherals

The different peripherals on the three input lines of each LUT are selected by writing to the respective LUT n Input y bit fields in the LUT n Control B and C registers:

- INSEL0 in CCL.LUTnCTRLB
- INSEL1 in CCL.LUTnCTRLB
- INSEL2 in CCL.LUTnCTRLC

### Related Links

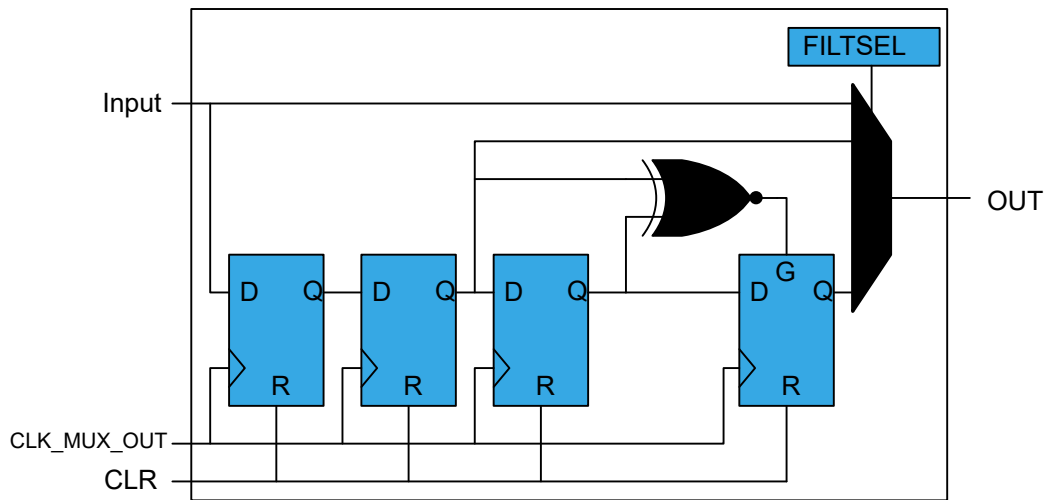
- 5. [I/O Multiplexing and Considerations](#)
- 16. [PORT - I/O Pin Configuration](#)
- 10. [CLKCTRL - Clock Controller](#)
- 29. [AC - Analog Comparator](#)
- 20. [TCA - 16-bit Timer/Counter Type A](#)
- 22. [TCD - 12-Bit Timer/Counter Type D](#)
- 24. [USART - Universal Synchronous and Asynchronous Receiver and Transmitter](#)
- 25. [SPI - Serial Peripheral Interface](#)
- 26. [TWI - Two-Wire Interface](#)
- 5. [I/O Multiplexing and Considerations](#)

#### 28.3.2.4 Filter

By default, the LUT output is a combinational function of the LUT inputs. This may cause some short glitches when the inputs change the value. These glitches can be removed by clocking through filters if demanded by application needs.

The Filter Selection bits (FILTSEL) in the LUT Control registers (CCL.LUTnCTRLA) define the digital filter options. When a filter is enabled, the output will be delayed by two to five CLK cycles (peripheral clock or alternative clock). One clock cycle after the corresponding LUT is disabled, all internal filter logic is cleared.

Figure 28-5. Filter



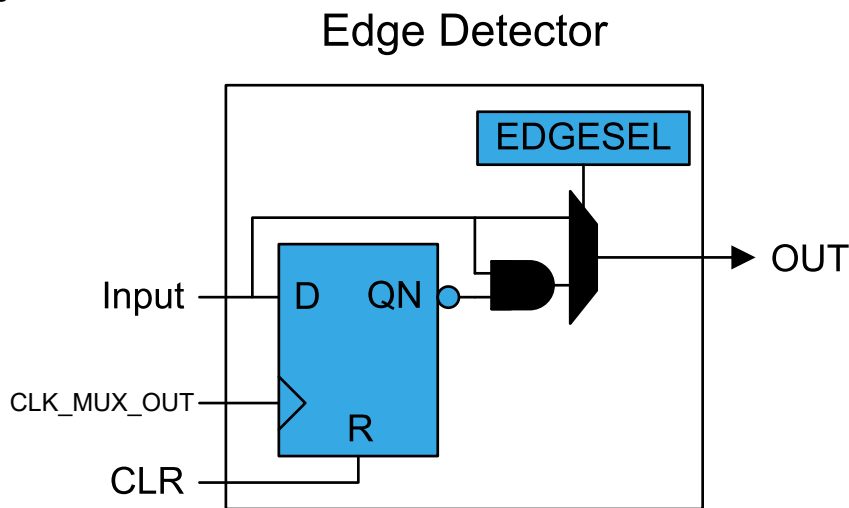
28.3.2.5 Edge Detector

The edge detector can be used to generate a pulse when detecting a rising edge on its input. To detect a falling edge, the TRUTH table should be programmed to provide inverted output.

The edge detector is enabled by writing '1' to the Edge Selection bit (EDGEDET) in the LUT n Control A register (CCL.LUTnCTRLA). In order to avoid unpredictable behavior, a valid filter option must be enabled as well.

Edge detection is disabled by writing a '0' to EDGEDET in CCL.LUTnCTRLA. After disabling an LUT, the corresponding internal Edge Detector logic is cleared one clock cycle later.

Figure 28-6. Edge Detector



28.3.2.6 Sequential Logic

Each LUT pair can be connected to an internal Sequential block. A Sequential block can function as either D flip-flop, JK flip-flop, gated D-latch, or RS-latch. The function is selected by writing the Sequential Selection bits (SEQSEL) in the Sequential Control register (CCL.SEQCTRLn).

The Sequential block receives its input from either LUT, filter, or edge detector, depending on the configuration.



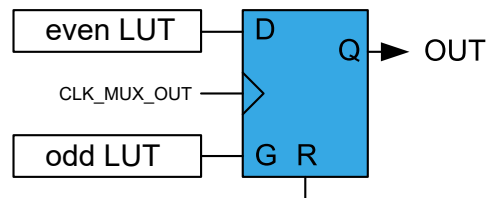
The Sequential block is clocked by the same clock as the corresponding LUT, which is either the peripheral clock or input line 2 (IN[2]). This is configured by the Clock Source bit (CLKSRC) in the LUT n Control A register (CCL.LUTnCTRLA).

When the even LUT (LUT0) is disabled, the latch is asynchronously cleared, during which the flip-flop Reset signal (R) is kept enabled for one clock cycle. In all other cases, the flip-flop output (OUT) is refreshed on the rising edge of the clock, as shown in the respective *Characteristics* tables.

### Gated D Flip-Flop (DFF)

The D-input is driven by the even LUT output (LUT0), and the G-input is driven by the odd LUT output (LUT1).

**Figure 28-7. D Flip-Flop**



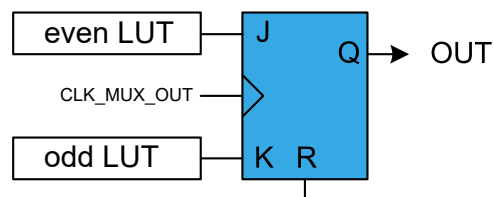
**Table 28-3. DFF Characteristics**

R	G	D	OUT
1	X	X	Clear
0	1	1	Set
		0	Clear
	0	X	Hold state (no change)

### JK Flip-Flop (JK)

The J-input is driven by the even LUT output (LUT0), and the K-input is driven by the odd LUT output (LUT1).

**Figure 28-8. JK Flip-Flop**



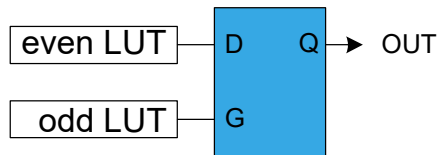
**Table 28-4. JK Characteristics**

R	J	K	OUT
1	X	X	Clear
0	0	0	Hold state (no change)
0	0	1	Clear
0	1	0	Set
0	1	1	Toggle

### Gated D-Latch (DLATCH)

The D-input is driven by the even LUT output (LUT0), and the G-input is driven by the odd LUT output (LUT1).

**Figure 28-9. D-Latch**



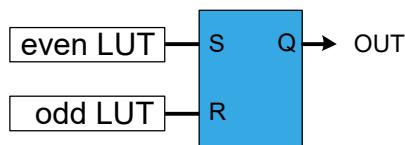
**Table 28-5. D-Latch Characteristics**

G	D	OUT
0	X	Hold state (no change)
1	0	Clear
1	1	Set

### RS-Latch (RS)

The S-input is driven by the even LUT output (LUT0), and the R-input is driven by the odd LUT output (LUT1).

**Figure 28-10. RS-Latch**



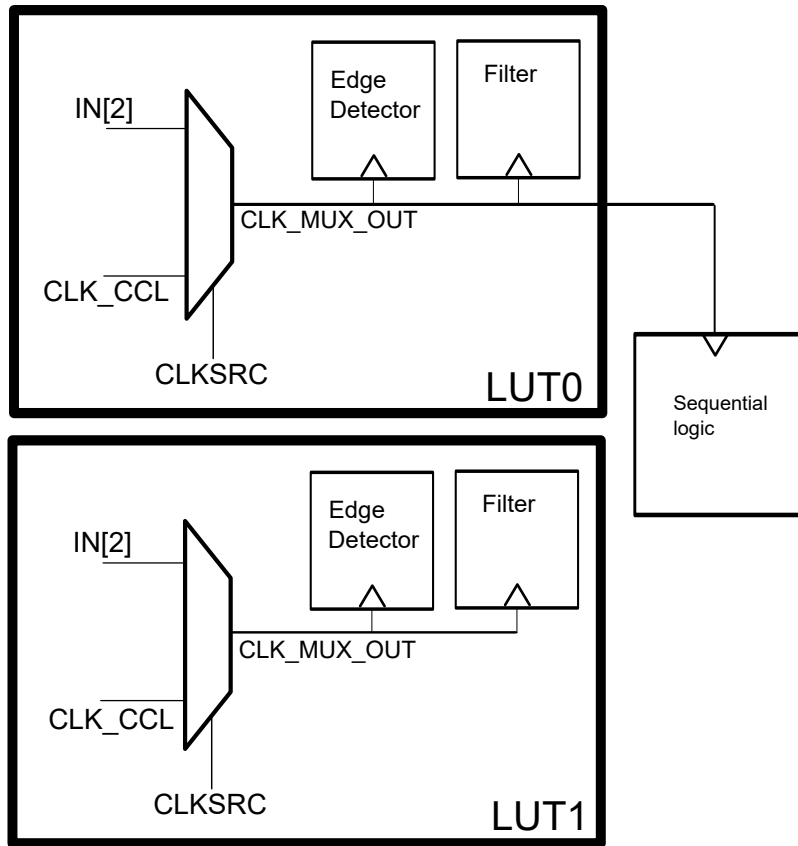
**Table 28-6. RS-Latch Characteristics**

S	R	OUT
0	0	Hold state (no change)
0	1	Clear
1	0	Set
1	1	Forbidden state

#### 28.3.2.7 Clock Source Settings

The Filter, Edge Detector, and Sequential logic are by default clocked by the system clock (CLK\_PER). It is also possible to use the LUT input 2 (IN[2]) to clock these blocks (CLK\_MUX\_OUT in [Figure 28-11](#)). This is configured by writing the Clock Source bit (CLKSRC) in the LUT Control A register (CCL.LUTnCTRLA) to '1'.

Figure 28-11. Clock Source Settings



When the Clock Source bit (CLKSRC) is '1', IN[2] is used to clock the corresponding Filter and Edge Detector (CLK\_MUX\_OUT). The Sequential logic is clocked by CLK\_MUX\_OUT of the even LUT in the pair. When CLKSRC bit is '1', IN[2] is treated as MASKed (low) in the TRUTH table.

The CCL peripheral must be disabled while changing the clock source to avoid undetermined outputs from the peripheral.

### 28.3.3 Interrupts

Table 28-7. Available Interrupt Vectors and Sources

Offset	Name	Vector Description	Conditions
0x00	CCL	CCL interrupt	INTn in CCL.INTFLAG is raised as configured by INTMODEn bits in CCL.INTCTRL0

When an interrupt condition occurs, the corresponding interrupt flag is set in the Interrupt Flags register of the peripheral (*peripheral*.INTFLAGS).

An interrupt source is enabled or disabled by writing to the corresponding enable bit in the peripheral's Interrupt Control register (*peripheral*.INTCTRL).

An interrupt request is generated when the corresponding interrupt source is enabled and the interrupt flag is set. The interrupt request remains active until the interrupt flag is cleared. See the peripheral's INTFLAGS register for details on how to clear interrupt flags.

When several interrupt request conditions are supported by an interrupt vector, the interrupt requests are ORed together into one combined interrupt request to the interrupt controller. The user must read the peripheral's INTFLAGS register to determine which of the interrupt conditions are present.

### 28.3.4 Events

The CCL can generate the following output events:

- LUTnOUT: Look-Up Table Output Value

The CCL can take the following actions on an input event:

- INx: The event is used as input for the TRUTH table

#### Related Links

[14. EVSYS - Event System](#)

### 28.3.5 Sleep Mode Operation

Writing the Run In Standby bit (RUNSTDBY) in the Control A register (CCL.CTRLA) to '1' will allow the system clock to be enabled in Standby Sleep mode.

If RUNSTDBY is '0' the system clock will be disabled in Standby Sleep mode. If the Filter, Edge Detector, or Sequential logic is enabled, the LUT output will be forced to '0' in Standby Sleep mode. In Idle sleep mode, the TRUTH table decoder will continue operation and the LUT output will be refreshed accordingly, regardless of the RUNSTDBY bit.

If the Clock Source bit (CLKSRC) in the LUT n Control A register (CCL.LUTnCTRLA) is written to '1', the LUT input 2 (IN[2]) will always clock the Filter, Edge Detector, and Sequential block. The availability of the IN[2] clock in sleep modes will depend on the sleep settings of the peripheral employed.

### 28.3.6 Configuration Change Protection

Not applicable.

## 28.4 Register Summary - CCL

Offset	Name	Bit Pos.							
0x00	<a href="#">CTRLA</a>	7:0		RUNSTDBY					ENABLE
0x01	<a href="#">SEQCTRL0</a>	7:0					SEQSEL[3:0]		
0x02	Reserved								
...									
0x04									
0x05	<a href="#">INTCTRL0</a>	7:0	INTMODE3[1:0]		INTMODE2[1:0]	INTMODE1[1:0]		INTMODE0[1:0]	
0x05	<a href="#">LUT0CTRLA</a>	7:0	EDGEDET	CLKSRC	FILTSEL[1:0]	OUTEN			ENABLE
0x06	<a href="#">LUT0CTRLB</a>	7:0	INSEL1[3:0]			INSEL0[3:0]			
0x07	<a href="#">INTFLAGS</a>	7:0						INT1	INT0
0x07	<a href="#">LUT0CTRLC</a>	7:0				INSEL2[3:0]			
0x08	<a href="#">TRUTH0</a>	7:0	TRUTH[7:0]						
0x09	<a href="#">LUT1CTRLA</a>	7:0	EDGEDET	CLKSRC	FILTSEL[1:0]	OUTEN			ENABLE
0x0A	<a href="#">LUT1CTRLB</a>	7:0	INSEL1[3:0]			INSEL0[3:0]			
0x0B	<a href="#">LUT1CTRLC</a>	7:0				INSEL2[3:0]			
0x0C	<a href="#">TRUTH1</a>	7:0	TRUTH[7:0]						

## 28.5 Register Description

### 28.5.1 Control A

**Name:** CTRLA  
**Offset:** 0x00  
**Reset:** 0x00  
**Property:** -

Bit	7	6	5	4	3	2	1	0
		RUNSTDBY						ENABLE
Access		R/W						R/W
Reset		0						0

**Bit 6 – RUNSTDBY** Run in Standby

This bit indicates if the peripheral clock (CLK\_PER) is kept running in Standby Sleep mode. The setting is ignored for configurations where the CLK\_PER is not required.

Value	Description
0	System clock is not required in Standby Sleep mode
1	System clock is required in Standby Sleep mode

**Bit 0 – ENABLE** Enable

Value	Description
0	The peripheral is disabled
1	The peripheral is enabled

### 28.5.2 Sequential Control 0

**Name:** SEQCTRL0  
**Offset:** 0x01 [ID-00000485]  
**Reset:** 0x00  
**Property:** Enable-Protected

	7	6	5	4	3	2	1	0
	SEQSEL[3:0]							
Access					R/W	R/W	R/W	R/W
Reset					0	0	0	0

**Bits 3:0 – SEQSEL[3:0]** Sequential Selection  
 These bits select the sequential configuration.

Value	Name	Description
0x0	DISABLE	Sequential logic is disabled
0x1	DFF	D flip-flop
0x2	JK	JK flip-flop
0x3	LATCH	D latch
0x4	RS	RS latch
Other	-	Reserved

### 28.5.3 Interrupt Control 0

**Name:** INTCTRL0  
**Offset:** 0x05  
**Reset:** 0x00  
**Property:** R/W

Bit	7	6	5	4	3	2	1	0
	INTMODE3[1:0]		INTMODE2[1:0]		INTMODE1[1:0]		INTMODE0[1:0]	
Access								
Reset	0	0	0	0	0	0	0	0

**Bits 0:1, 2:3, 4:5, 6:7 – INTMODE** The bits in INTMODE<sub>n</sub> select the interrupt sense configuration for LUT<sub>n</sub>-OUT.

Value	Name	Description
3	BOTH	Sense both edges
2	FALLING	Sense falling edge
1	RISING	Sense rising edge
0	INTDISABLE	Interrupt disabled



**28.5.4 Interrupt Flag**

**Name:** INTFLAGS  
**Offset:** 0x07  
**Reset:** 0  
**Property:** R/W

	7	6	5	4	3	2	1	0
Bit							INT1	INT0
Access								
Reset							0	0

**Bits 0, 1 – INT** Interrupt Flag

The INTn flag is set when LUTn output change matches the interrupt sense mode as defined in CCL.INTCTRLn. Writing a '1' to this flag's bit location will clear the flag.

### 28.5.5 LUT n Control A

**Name:** LUTCTRLA  
**Offset:** 0x05 + n\*0x04 [n=0..1]  
**Reset:** 0x00  
**Property:** Enable-Protected

Bit	7	6	5	4	3	2	1	0
	EDGEDET	CLKSRC	FILTSEL[1:0]		OUTEN			ENABLE
Access	R/W	R/W	R/W	R/W	R/W			R/W
Reset	0	0	0	0	0			0

#### Bit 7 – EDGEDET Edge Detection

Value	Description
0	Edge detector is disabled
1	Edge detector is enabled

#### Bit 6 – CLKSRC Clock Source Selection

This bit selects whether the peripheral clock (CLK\_PER) or any input present on input line 2 (IN[2]) is used as clock (CLK\_MUX\_OUT) for an LUT.

The CLK\_MUX\_OUT of the even LUT is used for clocking the Sequential block of an LUT pair.

Value	Description
0	CLK_PER is clocking the LUT
1	IN[2] is clocking the LUT

#### Bits 5:4 – FILTSEL[1:0] Filter Selection

These bits select the LUT output filter options:

Value	Name	Description
0x0	DISABLE	Filter disabled
0x1	SYNCH	Synchronizer enabled
0x2	FILTER	Filter enabled
0x3	-	Reserved

#### Bit 3 – OUTEN Output Enable

This bit enables the LUT output to the LUTnOUT pin. When written to '1', the pin configuration of the PORT I/O Controller is overridden.

Value	Description
0	Output to pin disabled
1	Output to pin enabled

#### Bit 0 – ENABLE LUT Enable

Value	Description
0	The LUT is disabled
1	The LUT is enabled

### 28.5.6 LUT n Control B

**Name:** LUTCTRLB  
**Offset:** 0x06 + n\*0x04 [n=0..1]  
**Reset:** 0x00  
**Property:** Enable-Protected

SPI connections to the CCL work only in master SPI mode.

USART connections to the CCL work only in asynchronous/synchronous USART Master mode.

Bit	7	6	5	4	3	2	1	0
	INSEL1[3:0]				INSEL0[3:0]			
Access	R/W	R/W	R/W	R/W	R/W	R/W	R/W	R/W
Reset	0	0	0	0	0	0	0	0

#### Bits 7:4 – INSEL1[3:0] LUT n Input 1 Source Selection

These bits select the source for input 1 of LUT n:

Value	Name	Description
0x0	MASK	Masked input
0x1	FEEDBACK	Feedback input
0x2	LINK	Linked other LUT as input source
0x3	EVENT0	Event 0 as input source for LUT0
0x4	EVENT1	Event 1 as input source for LUT1
0x5	IO	I/O pin LUTn-IN1 input source
0x6	AC0	AC0 OUT input source
0x7	TCB0	TCB WO input source
0x8	TCA0	TCA WO1 input source
0x9	TCD0	TCD WOB input source
0xA	USART0	USART TXD input source
0xB	SPI0	SPI MOSI input source
0xC	AC1	AC1 OUT input source
0xD	TCB1	TCB 1 W0 input source
0xE	AC2	AC2 OUT input source

#### Bits 3:0 – INSEL0[3:0] LUT n Input 0 Source Selection

These bits select the source for input 0 of LUT n:

Value	Name	Description
0x0	MASK	Masked input
0x1	FEEDBACK	Feedback input
0x2	LINK	Linked other LUT as input source
0x3	EVENT0	Event 0 as input source for LUT0
0x4	EVENT1	Event 1 as input source for LUT1
0x5	IO	I/O pin LUTn-IN0 input source
0x6	AC0	AC0 OUT input source
0x7	TCB0	TCB WO input source
0x8	TCA0	TCA WO0 input source
0x9	TCD0	TCD WOAn input source

Value	Name	Description
0xA	USART0	USART XCK input source
0xB	SPI0	SPI SCK input source
0xC	AC1	AC1 OUT input source
0xD	TCB1	TCB 1 W0 input source
0xE	AC2	AC2 OUT input source
Other	-	Reserved

### 28.5.7 LUT n Control C

**Name:** LUTCTRLC  
**Offset:** 0x07 + n\*0x04 [n=0..1]  
**Reset:** 0x00  
**Property:** Enable-Protected

	7	6	5	4	3	2	1	0
					INSEL2[3:0]			
Access					R/W	R/W	R/W	R/W
Reset					0	0	0	0

#### Bits 3:0 – INSEL2[3:0] LUT n Input 2 Source Selection

These bits select the source for input 2 of LUT n:

Value	Name	Description
0x0	MASK	Masked input
0x1	FEEDBACK	Feedback input
0x2	LINK	Linked other LUT as input source
0x3	EVENT0	Event input source 0
0x4	EVENT1	Event input source 1
0x5	IO	I/O pin LUTn-IN2 input source
0x6	AC0	AC0 OUT input source
0x7	TCB0	TCB WO input source
0x8	TCA0	TCA WO2 input source
0x9	TCD0	TCD WOA input source
0xA	-	Reserved
0xB	SPI0	SPI MISO input source
other	-	Reserved

**28.5.8 TRUTHn**

**Name:** TRUTH  
**Offset:** 0x08 + n\*0x04 [n=0..1]  
**Reset:** 0x00  
**Property:** Enable-Protected

Bit	7	6	5	4	3	2	1	0
	TRUTH[7:0]							
Access	R/W	R/W	R/W	R/W	R/W	R/W	R/W	R/W
Reset	0	0	0	0	0	0	0	0

**Bits 7:0 – TRUTH[7:0] Truth Table**

These bits define the value of truth logic as a function of inputs IN[2:0].

## 29. AC - Analog Comparator

### 29.1 Features

- Three Instances of the AC Controller, AC0, AC1, and AC2
- 50 ns Response Time for Supply Voltage Above 2.7V
- Zero-Cross Detection
- Selectable Hysteresis:
  - None
  - 10 mV
  - 25 mV
  - 50 mV
- Analog Comparator Output Available on Pin
- Comparator Output Inversion Available
- Flexible Input Selection:
  - Four Positive pins
  - Two Negative pins
  - Output from the DAC
  - Internal reference voltage
- Interrupt Generation On:
  - Rising edge
  - Falling edge
  - Both edges
- Event Generation:
  - Comparator output

### 29.2 Overview

The Analog Comparator (AC) compares the voltage levels on two inputs and gives a digital output based on this comparison. The AC can be configured to generate interrupt requests and/or events upon several different combinations of input change.

The dynamic behavior of the AC can be adjusted by a hysteresis feature. The hysteresis can be customized to optimize the operation for each application.

The input selection includes analog port pins, DAC output, and internal references. The analog comparator output state can also be output on a pin for use by external devices.

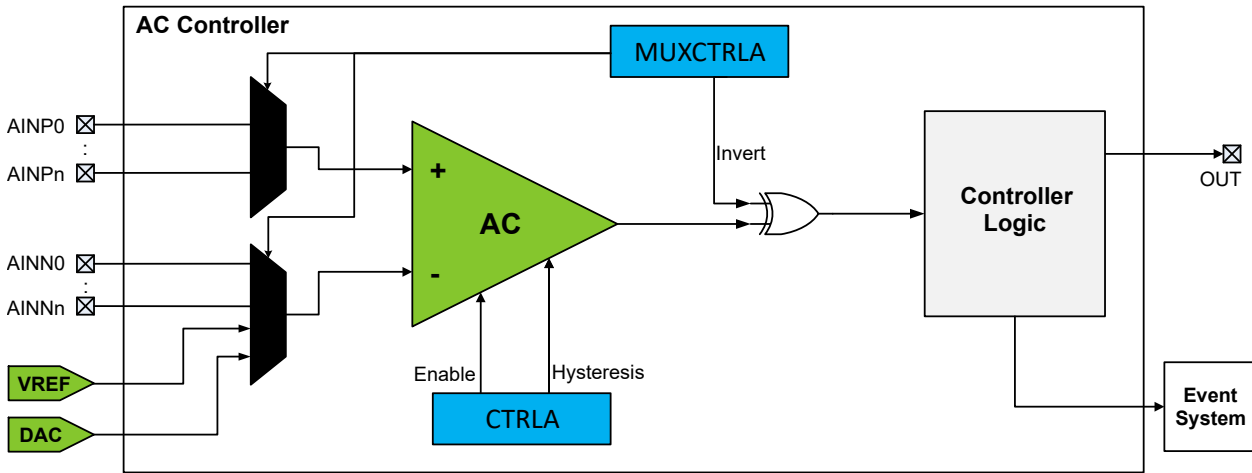
The AC has one positive input and one negative input. The positive input source is one of a selection of four analog input pins. The negative inputs are chosen either from analog input pins or from internal inputs, such as an internal voltage reference.

The digital output from the comparator is '1' when the difference between the positive and the negative input voltage is positive and '0' otherwise.

This device provides three instances of the AC controller, AC0, AC1, and AC2.

### 29.2.1 Block Diagram

Figure 29-1. Analog Comparator



**Note:** Refer to [29.2.2 Signal Description](#) for the number of AINN and AINP.

### 29.2.2 Signal Description

Signal	Description	Type
AINN0	Negative Input 0	Analog
AINN1	Negative Input 1	Analog
AINP0	Positive Input 0	Analog
AINP1	Positive Input 1	Analog
AINP2	Positive Input 2	Analog
AINP3	Positive Input 3	Analog
OUT	Comparator Output for AC	Digital

### 29.2.3 System Dependencies

In order to use this peripheral, other parts of the system must be configured correctly, as described below.

Table 29-1. AC System Dependencies

Dependency	Applicable	Peripheral
Clocks	Yes	CLKCTRL
I/O Lines and Connections	Yes	PORT
Interrupts	Yes	CPUINT
Events	Yes	EVSYS
Debug	Yes	UPDI

#### 29.2.3.1 Clocks

This peripheral depends on the peripheral clock.



### 29.2.3.2 I/O Lines and Connections

I/O pins AINN0-AINN1 and AINP0- AINP3 are all analog inputs to the AC.

For correct operation, the pins must be configured in the port and port multiplexing peripherals.

It is recommended to disable the GPIO input when using the AC.

### 29.2.3.3 Interrupts

Using the interrupts of this peripheral requires the interrupt controller to be configured first.

### 29.2.3.4 Events

The events of this peripheral are connected to the Event System.

### 29.2.3.5 Debug Operation

This peripheral is unaffected by entering Debug mode.

If the peripheral is configured to require periodical service by the CPU through interrupts or similar, improper operation or data loss may result during halted debugging.

## 29.3 Functional Description

### 29.3.1 Initialization

For basic operation, follow these steps:

- Configure the desired input pins in the port peripheral
- Select the positive and negative input sources by writing the Positive and Negative Input MUX Selection bit fields (MUXPOS and MUXNEG) in the MUX Control A register (AC.MUXCTRLA)
- Optional: Enable the output to pin by writing a '1' to the Output Pad Enable bit (OUTEN) in the Control A register (AC.CTRLA)
- Enable the AC by writing a '1' to the ENABLE bit in AC.CTRLA

During the start-up time after enabling the AC, the output of the AC may be invalid.

The start-up time of the AC by itself is at most 2.5  $\mu$ s. If an internal reference is used, the reference start-up time is normally longer than the AC start-up time. The VREF start-up time is 60  $\mu$ s at most.

### 29.3.2 Operation

#### 29.3.2.1 Input Hysteresis

Applying an input hysteresis helps to prevent constant toggling of the output when the noise-afflicted input signals are close to each other.

The input hysteresis can either be disabled or have one of three levels. The hysteresis is configured by writing to the Hysteresis Mode Select bit field (HYSMODE) in the Control A register (ACn.CTRLA).

#### 29.3.2.2 Input Sources

The AC has one positive and one negative input. The inputs can be pins and internal sources, such as a voltage reference.

Each input is selected by writing to the Positive and Negative Input MUX Selection bit field (MUXPOS and MUXNEG) in the MUX Control A register (AC.MUXCTRLA).

##### 29.3.2.2.1 Pin Inputs

The following Analog input pins on the port can be selected as input to the analog comparator:

- AINN0

- AINN1
- AINP0
- AINP1
- AINP2
- AINP3

### 29.3.2.2.2 Internal Inputs

Two internal inputs are available for the analog comparator:

- Output from the DAC
- DAC and AC voltage reference

### 29.3.2.3 Low-Power Mode

For power sensitive applications, the AC provides a Low-Power mode with reduced power consumption and increased propagation delay.

This mode is enabled by writing a '1' to the Low-Power Mode bit (LPMODE) in the Control A register (AC.CTRLA).

### 29.3.3 Events

The AC will generate the following event automatically when the AC is enabled:

- The digital output from the AC (OUT in the block diagram) is available as an Event System source. The events from the AC are asynchronous to any clocks in the device.

The AC has no event inputs.

### 29.3.4 Interrupts

**Table 29-2. Available Interrupt Vectors and Sources**

Offset	Name	Vector Description	Conditions
0x00	COMP0	Analog comparator interrupt	AC output is toggling as configured by INTMODE in AC.CTRLA

When an interrupt condition occurs, the corresponding interrupt flag is set in the STATUS register (AC.STATUS).

An interrupt source is enabled or disabled by writing to the corresponding bit in the peripheral's Interrupt Control register (AC.INTCTRL).

An interrupt request is generated when the corresponding interrupt source is enabled and the interrupt flag is set. The interrupt request remains active until the interrupt flag is cleared. See the AC.STATUS register description for details on how to clear interrupt flags.

### 29.3.5 Sleep Mode Operation

In Idle Sleep mode, the AC will continue to operate as normal.

In Standby Sleep mode, the AC is disabled by default. If the Run in Standby Sleep mode bit (RUNSTDBY) in the Control A register (AC.CTRLA) is written to '1', the AC will continue to operate, but the Status register will not be updated, and no Interrupts are generated if no other modules request the CLK\_PER, but events and the pad output will be updated.

In Power-Down Sleep mode, the AC and the output to the pad are disabled.

**29.3.6 Configuration Change Protection**  
Not applicable.

## 29.4 Register Summary - AC

Offset	Name	Bit Pos.							
0x00	<a href="#">CTRLA</a>	7:0	RUNSTDBY	OUTEN	INTMODE[1:0]	LPMODE	HYSMODE[1:0]	ENABLE	
0x01	Reserved								
0x02	<a href="#">MUXCTRLA</a>	7:0	INVERT		MUXPOS[1:0]		MUXNEG[1:0]		
0x03	Reserved								
...									
0x05									
0x06	<a href="#">INTCTRL</a>	7:0						CMP	
0x07	<a href="#">STATUS</a>	7:0			STATE			CMP	

## 29.5 Register Description

### 29.5.1 Control A

**Name:** CTRLA  
**Offset:** 0x00  
**Reset:** 0x00  
**Property:** -

Bit	7	6	5	4	3	2	1	0
	RUNSTDBY	OUTEN	INTMODE[1:0]		LPMODE	HYSMODE[1:0]		ENABLE
Access	R/W	R/W	R/W	R/W	R/W	R/W	R/W	R/W
Reset	0	0	0	0	0	0	0	0

#### Bit 7 – RUNSTDBY Run in Standby Mode

Writing a '1' to this bit allows the AC to continue operation in Standby Sleep mode. Since the clock is stopped, interrupts and status flags are not updated.

Value	Description
0	In Standby Sleep mode, the peripheral is halted
1	In Standby Sleep mode, the peripheral continues operation

#### Bit 6 – OUTEN Analog Comparator Output Pad Enable

Writing this bit to '1' makes the OUT signal available on the pin.

#### Bits 5:4 – INTMODE[1:0] Interrupt Modes

Writing to these bits selects what edges of the AC output triggers an interrupt request.

Value	Name	Description
0x0	BOTHEDGE	Both negative and positive edge
0x1	-	Reserved
0x2	NEGEDGE	Negative edge
0x3	POSEDGE	Positive edge

#### Bit 3 – LPMODE Low-Power Mode

Writing a '1' to this bit reduces the current through the comparator. This reduces the power consumption but increases the reaction time of the AC.

Value	Description
0	Low-Power mode disabled
1	Low-Power mode enabled

#### Bits 2:1 – HYSMODE[1:0] Hysteresis Mode Select

Writing these bits selects the Hysteresis mode for the AC input.

Value	Name	Description
0x0	OFF	OFF
0x1	10	±10 mV
0x2	25	±25 mV
0x3	50	±50 mV

**Bit 0 – ENABLE** Enable AC  
Writing this bit to '1' enables the AC.

### 29.5.2 MUX Control A

**Name:** MUXCTRLA  
**Offset:** 0x02  
**Reset:** 0x00  
**Property:** -

AC.MUXCTRLA controls the analog comparator MUXes.

	7	6	5	4	3	2	1	0
	INVERT			MUXPOS[1:0]			MUXNEG[1:0]	
Access	R/W			R/W	R/W		R/W	R/W
Reset	0			0	0		0	0

**Bit 7 – INVERT** Invert AC Output

Writing a ‘1’ to this bit enables inversion of the output of the AC. This effectively inverts the input to all the peripherals connected to the signal and affects the internal status signals.

**Bits 4:3 – MUXPOS[1:0]** Positive Input MUX Selection

Writing to this bit field selects the input signal to the positive input of the AC.

Value	Name	Description
0x0	AINP0	Positive Pin 0
0x1	AINP1	Positive Pin 1
0x2	AINP2	Positive Pin 2
0x3	AINP3	Positive Pin 3

**Bits 1:0 – MUXNEG[1:0]** Negative Input MUX Selection

Writing to this bit field selects the input signal to the negative input of the AC.

Value	Name	Description
0x0	AINN0	Negative Pin 0
0x1	AINN1	Negative Pin 1
0x2	VREF	Voltage Reference
0x3	DAC	DAC output Instance n of the AC will use instance n of the DAC: for example AC0 will use DAC0 and AC1 will use DAC1.

**29.5.3 Interrupt Control**

**Name:** INTCTRL  
**Offset:** 0x06  
**Reset:** 0x00  
**Property:** -

Bit	7	6	5	4	3	2	1	0
								CMP
Access								R/W
Reset								0

**Bit 0 – CMP** Analog Comparator Interrupt Enable  
Writing this bit to '1' enables analog comparator interrupt.



### 29.5.4 Status

**Name:** STATUS  
**Offset:** 0x07  
**Reset:** 0x00  
**Property:** -

	7	6	5	4	3	2	1	0
				STATE				CMP
Access				R				R/W
Reset				0				0

**Bit 4 – STATE** Analog Comparator State

This shows the current status of the OUT signal from the AC. This will have a synchronizer delay to get updated in the I/O register (three cycles).

**Bit 0 – CMP** Analog Comparator Interrupt Flag

This is the interrupt flag for AC. Writing a '1' to this bit will clear the Interrupt Flag.

## 30. ADC - Analog-to-Digital Converter

### 30.1 Features

- 10-Bit Resolution
- $\pm 2$  LSB Absolute Accuracy
- 6.5 - 260  $\mu$ s Conversion Time
- Up to 115 ksps at 10-Bit Resolution (150 ksps at 8-bit)
- Up to Ten Multiplexed Single-ended Input Channels
- Temperature Sensor Input Channel
- 0V to  $V_{DD}$  ADC Input Voltage Range
- Multiple Internal ADC Reference Voltages Between 0.55V and  $V_{DD}$
- External Reference Input  $V_{VREFA}$
- Free-running or Single Conversion mode
- Interrupt Available on ADC Conversion Complete
- Optional Event Triggered Conversion
- Optional Interrupt on Conversion Results
- Compare Function for Accurate Monitoring or User-Defined Thresholds (Window Comparator mode)
- Accumulation up to 64 Samples per Conversion

### 30.2 Overview

The Analog-to-Digital Converter (ADC) peripheral features a 10-bit Successive Approximation ADC (SAR), with a sampling rate up to 115 ksps at 10-bit resolution (150 ksps at 8-bit). The ADC is connected to a 10-channel analog multiplexer, which allows twelve single-ended voltage inputs. The single-ended voltage inputs refer to 0V (GND). The ADC input channel can either be internal (e.g. a voltage reference) or external through the analog input pins.

An ADC conversion can be started by software or by using the Event System (EVSYS) to route an event from other peripherals, making it possible to do a periodic sampling of input signals, trigger an ADC conversion on a special condition, or trigger an ADC conversion in Standby Sleep mode. A window compare feature is available for monitoring the input signal and can be configured to only trigger an interrupt on user-defined thresholds for under, over, inside, or outside a window, with minimum software intervention required.

The ADC input signal is fed through a sample-and-hold circuit that ensures that the input voltage to the ADC is held at a constant level during sampling.

The ADC supports sampling in bursts where a configurable number of conversion results are accumulated into a single ADC result (Sample Accumulation). Further, a sample delay can be configured to tune the ADC sampling frequency associated with a single burst. This is to tune the sampling frequency away from any harmonic noise aliased with the ADC sampling frequency (within the burst) from the sampled signal. An automatic sampling delay variation feature can be used to randomize this delay to slightly change the time between samples.

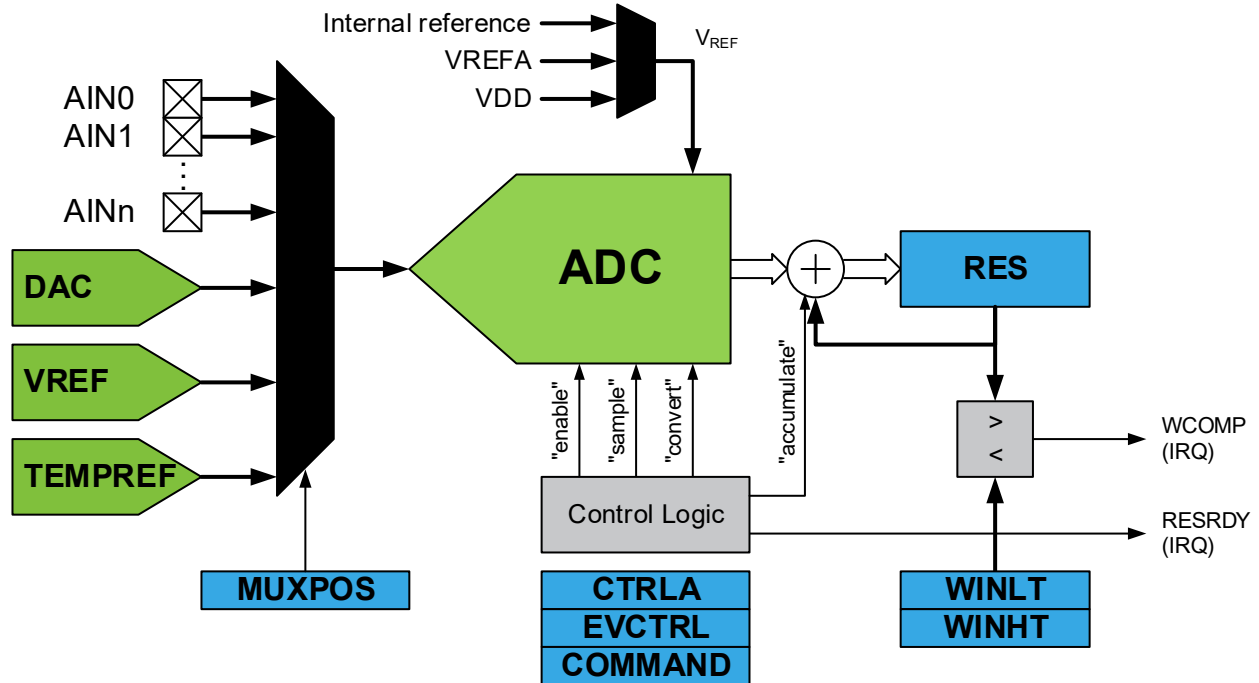
Selectable voltage references from the internal Voltage Reference (VREF) peripheral,  $V_{DD}$  supply voltage, or external VREF pin (VREFA).

This device has two instances of the ADC; ADC0 and ADC1.

When the Peripheral Touch Controller (PTC) is enabled, ADC0 is fully controlled by the PTC peripheral.

### 30.2.1 Block Diagram

Figure 30-1. Block Diagram



The analog input channel is selected by writing to the MUXPOS bits in the MUXPOS register (ADC.MUXPOS). Any of the ADC input pins, GND, or temperature sensor, can be selected as single-ended input to the ADC. The ADC is enabled by writing a '1' to the ADC ENABLE bit in the Control A register (ADC.CTRLA). Voltage reference and input channel selections will not go into effect before the ADC is enabled. The ADC does not consume power when the ENABLE bit in ADC.CTRLA is '0'.

The ADC generates a 10-bit result that can be read from the Result Register (ADC.RES). The result is presented right adjusted.

### 30.2.2 Signal Description

Pin Name	Type	Description
AIN[11, 10, 7:0]	Analog input	Analog input to be converted
VREFA	Analog input	Analog reference input

#### Related Links

- [1.1 Configuration Summary](#)
- [5. I/O Multiplexing and Considerations](#)

### 30.2.3 System Dependencies

In order to use this peripheral, other parts of the system must be configured correctly, as described below.

**Table 30-1. ADC System Dependencies**

Dependency	Applicable	Peripheral
Clocks	Yes	CLKCTRL
I/O Lines and Connections	Yes	PORT
Interrupts	Yes	CPUINT
Events	Yes	EVSYS
Debug	Yes	UPDI

### 30.2.3.1 Clocks

The ADC uses the peripheral clock CLK\_PER and has an internal prescaler to generate the ADC clock source CLK\_ADC.

#### Related Links

- [10. CLKCTRL - Clock Controller](#)
- [30.3.2.2 Clock Generation](#)

### 30.2.3.2 I/O Lines and Connections

The I/O pins (AINx and VREF) are configured by the port - I/O Pin Controller.

The digital input buffer should be disabled on the pin used as input for the ADC to disconnect the digital domain from the analog domain to obtain the best possible ADC results. This is configured by the port - I/O Pin Controller.

#### Related Links

- [16. PORT - I/O Pin Configuration](#)

### 30.2.3.3 Interrupts

Using the interrupts of this peripheral requires the interrupt controller to be configured first.

#### Related Links

- [13. CPUINT - CPU Interrupt Controller](#)
- [8.7.3 SREG](#)
- [30.3.4 Interrupts](#)

### 30.2.3.4 Events

The events of this peripheral are connected to the Event System.

#### Related Links

- [14. EVSYS - Event System](#)

### 30.2.3.5 Debug Operation

When run-time debugging, this peripheral will continue normal operation. Halting the CPU in Debugging mode will halt normal operation of the peripheral.

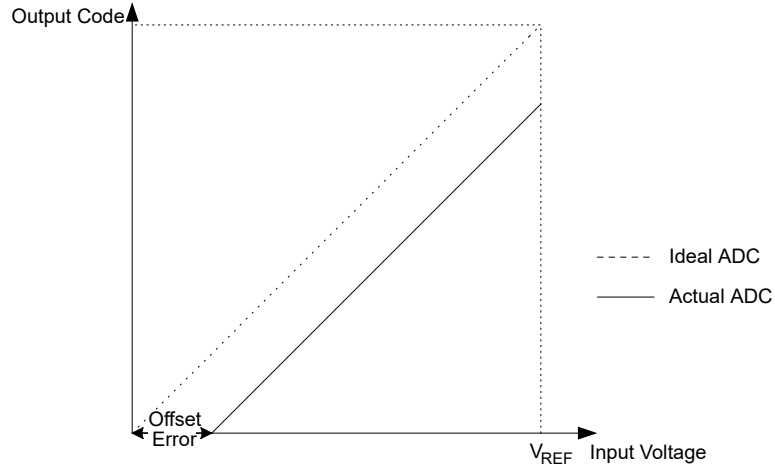
This peripheral can be forced to operate with halted CPU by writing a '1' to the Debug Run bit (DBGRUN) in the Debug Control register of the peripheral (*peripheral*.DBGCTRL).

**30.2.4 Definitions**

An ideal n-bit single-ended ADC converts a voltage linearly between GND and VREF in  $2^n$  steps (LSb). The lowest code is read as 0, and the highest code is read as  $2^n - 1$ . Several parameters describe the deviation from the ideal behavior:

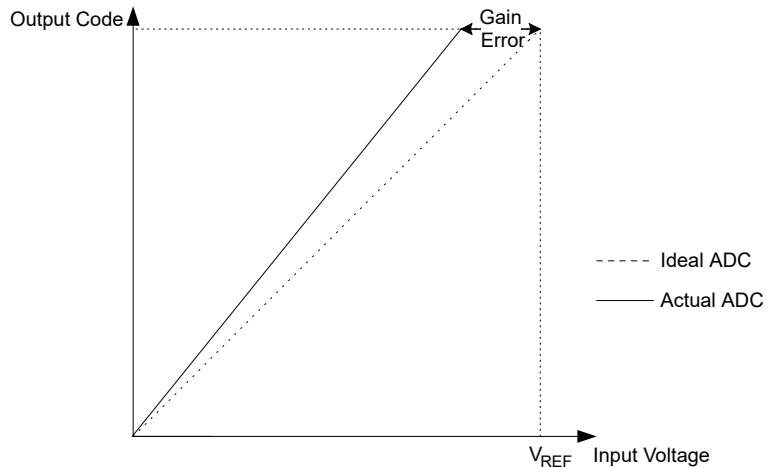
**Offset Error** The deviation of the first transition (0x000 to 0x001) compared to the ideal transition (at 0.5 LSb). Ideal value: 0 LSb.

**Figure 30-2. Offset Error**



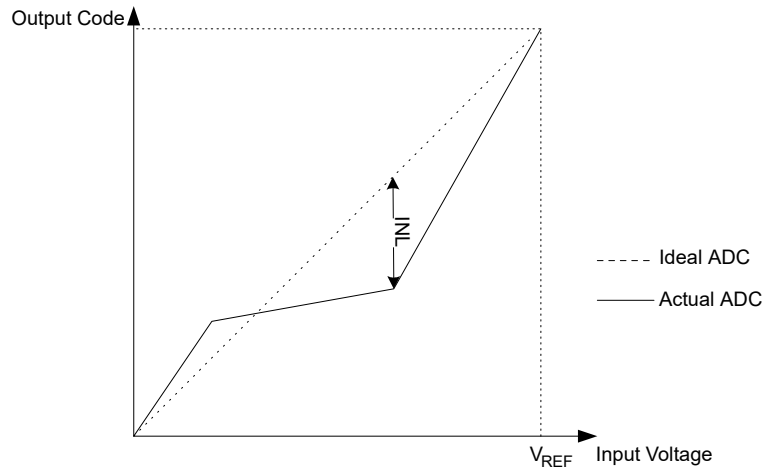
**Gain Error** After adjusting for offset, the gain error is found as the deviation of the last transition (0x3FE to 0x3FF) compared to the ideal transition (at 1.5 LSb below maximum). Ideal value: 0 LSb.

**Figure 30-3. Gain Error**



**Integral Non-Linearity (INL)** After adjusting for offset and gain error, the INL is the maximum deviation of an actual transition compared to an ideal transition for any code. Ideal value: 0 LSb.

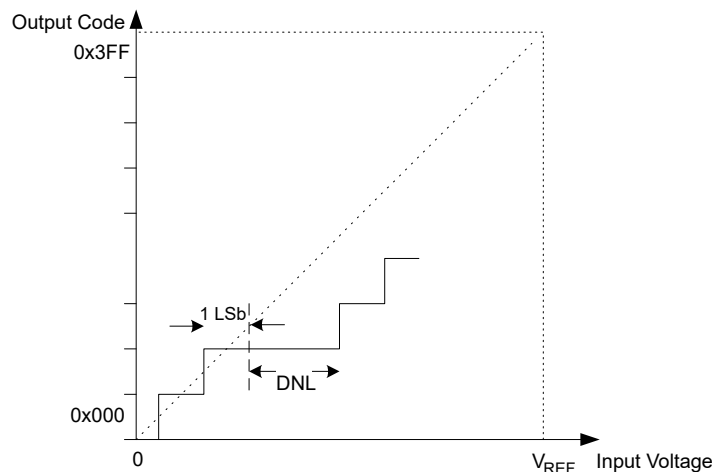
**Figure 30-4. Integral Non-Linearity**



**Differential Non-Linearity (DNL)**

The maximum deviation of the actual code width (the interval between two adjacent transitions) from the ideal code width (1 LSb). Ideal value: 0 LSb.

**Figure 30-5. Differential Non-Linearity**



**Quantization Error**

Due to the quantization of the input voltage into a finite number of codes, a range of input voltages (1 LSb wide) will code to the same value. Always  $\pm 0.5$  LSb.

**Absolute Accuracy**

The maximum deviation of an actual (unadjusted) transition compared to an ideal transition for any code. This is the compound effect of all aforementioned errors. Ideal value:  $\pm 0.5$  LSb.

### 30.3 Functional Description

#### 30.3.1 Initialization

The following steps are recommended in order to initialize ADC operation:

1. Configure the resolution by writing to the Resolution Selection bit (RESSEL) in the Control A register (ADC.CTRLA).
2. Optional: Enable the Free-Running mode by writing a '1' to the Free-Running bit (FREERUN) in ADC.CTRLA.

3. Optional: Configure the number of samples to be accumulated per conversion by writing the Sample Accumulation Number Select bits (SAMPNUM) in the Control B register (ADC.CTRLB).
4. Configure a voltage reference by writing to the Reference Selection bit (REFSEL) in the Control C register (ADC.CTRLA). Default is the internal voltage reference of the device (VREF, as configured there).
5. Configure the CLK\_ADC by writing to the Prescaler bit field (PRESC) in the Control C register (ADC.CTRLA).
6. Configure an input by writing to the MUXPOS bit field in the MUXPOS register (ADC.MUXPOS).
7. Optional: Enable Start Event input by writing a '1' to the Start Event Input bit (STARTEI) in the Event Control register (ADC.EVCTRL). Configure the Event System accordingly.
8. Enable the ADC by writing a '1' to the ENABLE bit in ADC.CTRLA.

Following these steps will initialize the ADC for basic measurements, which can be triggered by an event (if configured) or by writing a '1' to the Start Conversion bit (STCONV) in the Command register (ADC.COMMAND).

### 30.3.2 Operation

#### 30.3.2.1 Starting a Conversion

Once the input channel is selected by writing to the MUXPOS register (ADCn.MUXPOS), a conversion is triggered by writing a '1' to the ADC Start Conversion bit (STCONV) in the Command register (ADCn.COMMAND). This bit is '1' as long as the conversion is in progress. In Single Conversion mode, STCONV is cleared by hardware when the conversion is completed.

If a different input channel is selected while a conversion is in progress, the ADC will finish the current conversion before changing the channel.

Depending on the accumulator setting, the conversion result is from a single sensing operation, or from a sequence of accumulated samples. Once the triggered operation is finished, the Result Ready flag (RESRDY) in the Interrupt Flag register (ADCn.INTFLAG) is set. The corresponding interrupt vector is executed if the Result Ready Interrupt Enable bit (RESRDY) in the Interrupt Control register (ADCn.INTCTRL) is '1' and the Global Interrupt Enable bit is '1'.

A single conversion can be started by writing a '1' to the STCONV bit in ADCn.COMMAND. The STCONV bit can be used to determine if a conversion is in progress. The STCONV bit will be set during a conversion and cleared once the conversion is complete.

The RESRDY interrupt flag in ADCn.INTFLAG will be set even if the specific interrupt is disabled, allowing software to check for finished conversion by polling the flag. A conversion can thus be triggered without causing an interrupt.

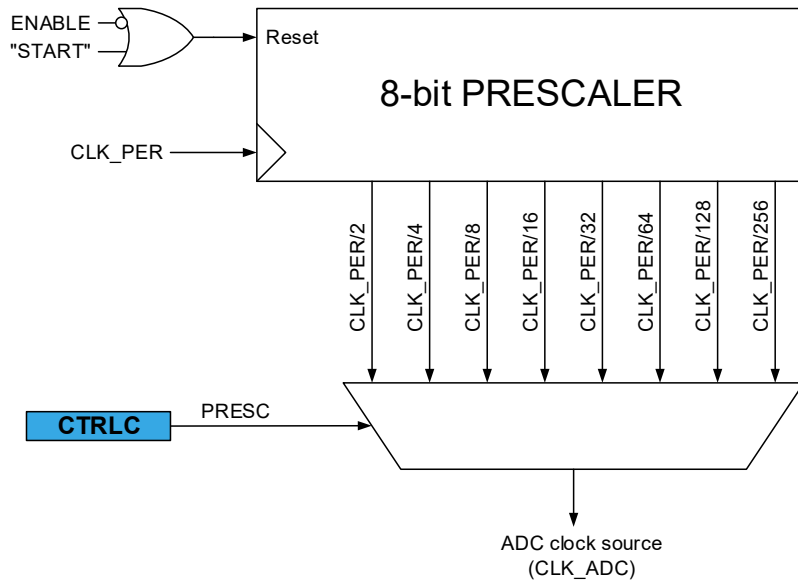
Alternatively, a conversion can be triggered by an event. This is enabled by writing a '1' to the Start Event Input bit (STARTEI) in the Event Control register (ADCn.EVCTRL). Any incoming event routed to the ADC through the Event System (EVSYS) will trigger an ADC conversion. This provides a method to start conversions at predictable intervals or at specific conditions.

The event trigger input is edge sensitive. When an event occurs, STCONV in ADCn.COMMAND is set. STCONV will be cleared when the conversion is complete.

In Free-Running mode, the first conversion is started by writing the STCONV bit to '1' in ADCn.COMMAND. A new conversion cycle is started immediately after the previous conversion cycle has completed. A conversion complete will set the RESRDY flag in ADCn.INTFLAGS.

### 30.3.2.2 Clock Generation

**Figure 30-6. ADC Prescaler**



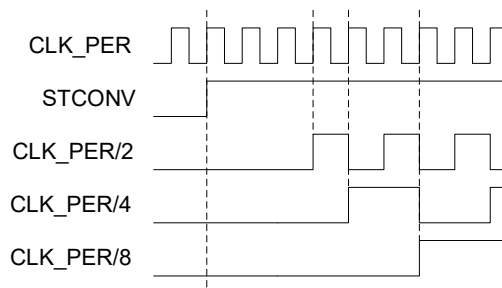
The ADC requires an input clock frequency between 50 kHz and 1.5 MHz for maximum resolution. If a lower resolution than 10 bits is selected, the input clock frequency to the ADC can be higher than 1.5 MHz to get a higher sample rate.

The ADC module contains a prescaler which generates the ADC clock (CLK\_ADC) from any CPU clock (CLK\_PER) above 100 kHz. The prescaling is selected by writing to the Prescaler bits (PRESC) in the Control C register (ADCn.CTRLC). The prescaler starts counting from the moment the ADC is switched on by writing a '1' to the ENABLE bit in ADCn.CTRLA. The prescaler keeps running as long as the ENABLE bit is '1'. The prescaler counter is reset to zero when the ENABLE bit is '0'.

When initiating a conversion by writing a '1' to the Start Conversion bit (STCONV) in the Command register (ADCn.COMMAND) or from an event, the conversion starts at the following rising edge of the CLK\_ADC clock cycle. The prescaler is kept reset as long as there is no ongoing conversion. This assures a fixed delay from the trigger to the actual start of a conversion in CLK\_PER cycles as:

$$\text{StartDelay} = \frac{\text{PRESC}_{\text{factor}}}{2} + 2$$

**Figure 30-7. Start Conversion and Clock Generation**



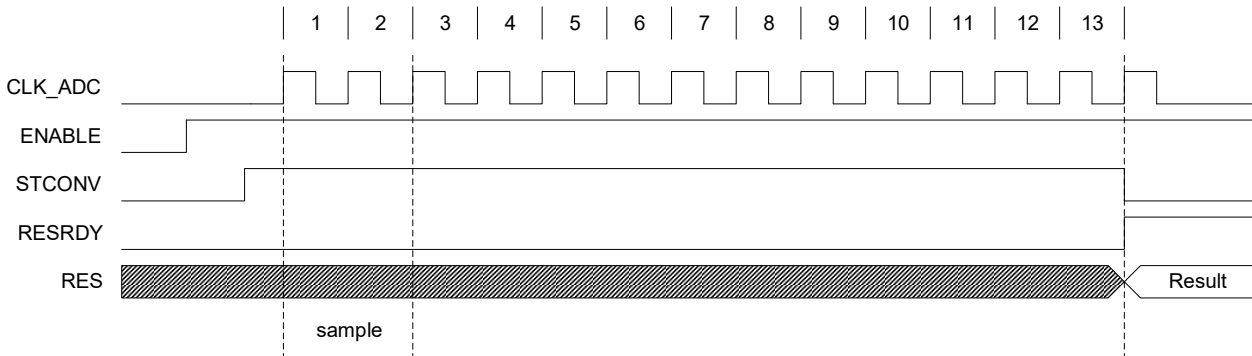
### 30.3.2.3 Conversion Timing

A normal conversion takes 13 CLK\_ADC cycles. The actual sample-and-hold takes place two CLK\_ADC cycles after the start of a conversion. Start of conversion is initiated by writing a '1' to the STCONV bit in ADC.COMMAND. When a conversion is complete, the result is available in the Result register (ADC.RES), and the Result Ready interrupt flag is set (RESRDY in ADC.INTFLAG). The interrupt flag will



be cleared when the result is read from the Result registers, or by writing a '1' to the RESRDY bit in ADC.INTFLAG.

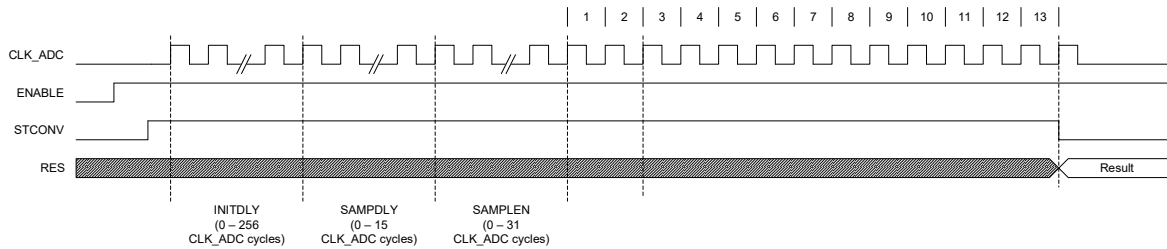
**Figure 30-8. ADC Timing Diagram - Single Conversion**



Both sampling time and sampling length can be adjusted using the Sample Delay bit field in Control D (ADC.CTRLD) and sampling the Sample Length bit field in the Sample Control register (ADC.SAMPCTRL). Both of these control the ADC sampling time in a number of CLK\_ADC cycles. This allows sampling high-impedance sources without relaxing conversion speed. See the register description for further information. Total sampling time is given by:

$$\text{SampleTime} = \frac{(2 + \text{SAMPDLY} + \text{SAMPLN})}{f_{\text{CLK\_ADC}}}$$

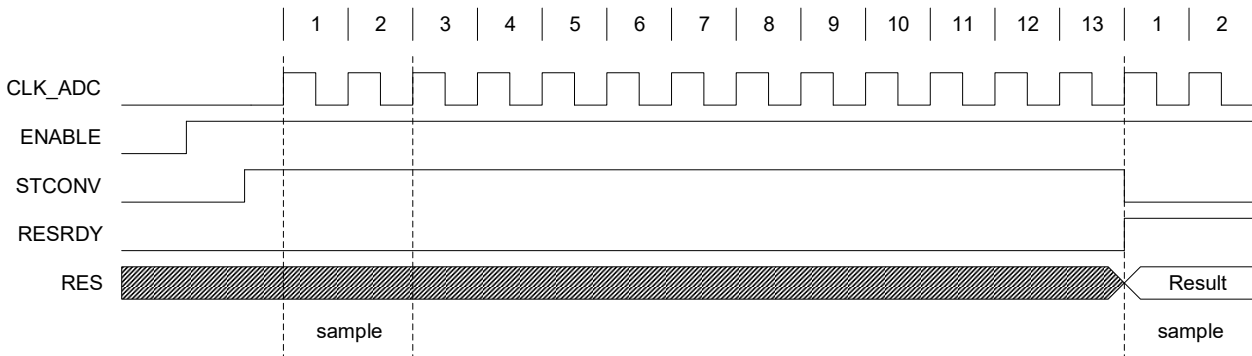
**Figure 30-9. ADC Timing Diagram - Single Conversion With Delays**



In Free-Running mode, a new conversion will be started immediately after the conversion completes, while the STCONV bit is '1'. The sampling rate  $R_S$  in free-running mode is calculated by:

$$R_S = \frac{f_{\text{CLK\_ADC}}}{(13 + \text{SAMPDLY} + \text{SAMPLN})}$$

**Figure 30-10. ADC Timing Diagram - Free-Running Conversion**



### 30.3.2.4 Changing Channel or Reference Selection

The MUXPOS bits in the ADCn.MUXPOS register and the REFSEL bits in the ADCn.CTRLA register are buffered through a temporary register to which the CPU has random access. This ensures that the channel and reference selections only take place at a safe point during the conversion. The channel and reference selections are continuously updated until a conversion is started.

Once the conversion starts, the channel and reference selections are locked to ensure sufficient sampling time for the ADC. Continuous updating resumes in the last CLK\_ADC clock cycle before the conversion completes (RESRDY in ADCn.INTFLAGS is set). The conversion starts on the following rising CLK\_ADC clock edge after the STCONV bit is written to '1'.

#### 30.3.2.4.1 ADC Input Channels

When changing channel selection, the user should observe the following guidelines to ensure that the correct channel is selected:

In Single Conversion mode: The channel should be selected before starting the conversion. The channel selection may be changed one ADC clock cycle after writing '1' to the STCONV bit.

In Free-Running mode: The channel should be selected before starting the first conversion. The channel selection may be changed one ADC clock cycle after writing '1' to the STCONV bit. Since the next conversion has already started automatically, the next result will reflect the previous channel selection. Subsequent conversions will reflect the new channel selection.

The ADC requires a settling time after switching the input channel - refer to the Electrical Characteristics section for details.

#### 30.3.2.4.2 ADC Voltage Reference

The reference voltage for the ADC ( $V_{REF}$ ) controls the conversion range of the ADC. Input voltages that exceed the selected  $V_{REF}$  will be converted to the maximum result value of the ADC, for an ideal 10-bit ADC this is 0x3FF.  $V_{REF}$  can be selected by writing the Reference Selection bits (REFSEL) in the Control C register (ADC.CTRLA) as either  $V_{DD}$ , external reference  $V_{REFA}$ , or an internal reference from the VREF peripheral.  $V_{DD}$  is connected to the ADC through a passive switch.

When using the external reference voltage  $V_{REFA}$ , configure ADCnREFSEL[0:2] in the corresponding VREF.CTRLn register to the value that is closest, but above the applied reference voltage. For external references higher than 4.3V, use ADCnREFSEL[0:2] = 0x3.

The internal reference is generated from an internal bandgap reference through an internal amplifier, and is controlled by the Voltage Reference (VREF) peripheral.

#### Related Links

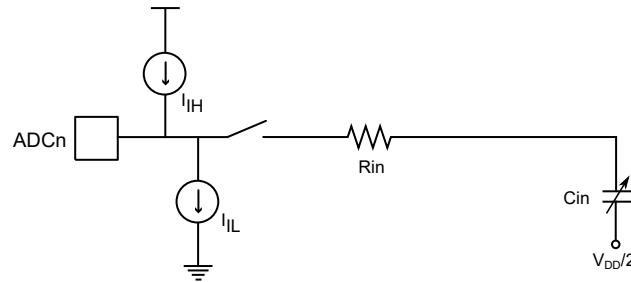
[18. VREF - Voltage Reference](#)

#### 30.3.2.4.3 Analog Input Circuitry

The analog input circuitry is illustrated in [Figure 30-11](#). An analog source applied to ADCn is subjected to the pin capacitance and input leakage of that pin (represented by  $I_H$  and  $I_L$ ), regardless of whether that channel is selected as input for the ADC. When the channel is selected, the source must drive the S/H capacitor through the series resistance (combined resistance in the input path).

The ADC is optimized for analog signals with an output impedance of approximately 10 k $\Omega$  or less. If such source is used, the sampling time will be negligible. If a source with higher impedance is used, the sampling time will depend on how long the source needs to charge the S/H capacitor, which can vary substantially.

**Figure 30-11. Analog Input Schematic**



### 30.3.2.5 ADC Conversion Result

After the conversion is complete (RESRDY is '1'), the conversion result RES is available in the ADC Result Register (ADCn.RES). The result for a 10-bit conversion is given as:

$$RES = \frac{1023 \times V_{IN}}{V_{REF}}$$

where  $V_{IN}$  is the voltage on the selected input pin and  $V_{REF}$  the selected voltage reference (see description for REFSEL in ADCn.CTRLA and ADCn.MUXPOS).

### 30.3.2.6 Temperature Measurement

The temperature measurement is based on an on-chip temperature sensor. For a temperature measurement, follow these steps:

1. Configure the internal voltage reference to 1.1V by configuring the VREF peripheral.
2. Select the internal voltage reference by writing the REFSEL bits in ADCn.CTRLA to 0x0.
3. Select the ADC temperature sensor channel by configuring the MUXPOS register (ADCn.MUXPOS). This enables the temperature sensor.
4. In ADCn.CTRLD select  $INITDLY \geq 32 \mu s \times f_{CLK\_ADC}$
5. In ADCn.SAMPCTRL select  $SAMPLEN \geq 32 \mu s \times f_{CLK\_ADC}$
6. In ADCn.CTRLA select  $SAMPCAP = 1$
7. Acquire the temperature sensor output voltage by starting a conversion.
8. Process the measurement result as described below.

The measured voltage has a linear relationship to the temperature. Due to process variations, the temperature sensor output voltage varies between individual devices at the same temperature. The individual compensation factors are determined during the production test and saved in the Signature Row:

- SIGROW.TEMPSENSE0 is a gain/slope correction
- SIGROW.TEMPSENSE1 is an offset correction

In order to achieve accurate results, the result of the temperature sensor measurement must be processed in the application software using factory calibration values. The temperature (in Kelvin) is calculated by this rule:

```
Temp = (((RESH << 8) | RESL) - TEMPSENSE1) * TEMPSENSE0 >> 8
```

RESH and RESL are the high and low bytes of the Result register (ADCn.RES), and TEMPSENSEn are the respective values from the Signature row.

It is recommended to follow these steps in user code:

```
int8_t sigrow_offset = SIGROW.TEMPSENSE1; // Read signed value from signature row
uint8_t sigrow_gain = SIGROW.TEMPSENSE0; // Read unsigned value from signature row
```

```
uint16_t adc_reading = 0; // ADC conversion result with 1.1 V internal reference

uint32_t temp = adc_reading - sigrow_offset;
temp *= sigrow_gain; // Result might overflow 16 bit variable (10bit+8bit)
temp += 0x80; // Add 1/2 to get correct rounding on division below
temp >>= 8; // Divide result to get Kelvin
uint16_t temperature_in_K = temp;
```

### Related Links

[6.10.2.3 TEMPSENSEn](#)

### 30.3.2.7 Window Comparator Mode

The ADC can raise the WCOMP flag in the Interrupt and Flag register (ADCn.INTFLAG) and request an interrupt (WCOMP) when the result of a conversion is above and/or below certain thresholds. The available modes are:

- The result is under a threshold
- The result is over a threshold
- The result is inside a window (above a lower threshold, but below the upper one)
- The result is outside a window (either under the lower or above the upper threshold)

The thresholds are defined by writing to the Window Comparator Threshold registers (ADCn.WINLT and ADCn.WINHT). Writing to the Window Comparator mode bit field (WINCM) in the Control E register (ADCn.CTRL E) selects the conditions when the flag is raised and/or the interrupt is requested.

Assuming the ADC is already configured to run, follow these steps to use the Window Comparator mode:

1. Choose which Window Comparator to use (see the WINCM description in ADCn.CTRL E), and set the required threshold(s) by writing to ADCn.WINLT and/or ADCn.WINHT.
2. Optional: enable the interrupt request by writing a '1' to the Window Comparator Interrupt Enable bit (WCOMP) in the Interrupt Control register (ADCn.INTCTRL).
3. Enable the Window Comparator and select a mode by writing a non-zero value to the WINCM bit field in ADCn.CTRL E.

When accumulating multiple samples, the comparison between the result and the threshold will happen after the last sample was acquired. Consequently, the flag is raised only once, after taking the last sample of the accumulation.

### 30.3.2.8 PTC Operation

When the Peripheral Touch Controller (PTC) is enabled, it takes complete control of ADC0.

When the PTC is disabled, ADC0 is available as a normal ADC.

Refer to the QTouch Library user guide for more details on using the PTC.

### Related Links

[32.6 Functional Description](#)

### 30.3.3 Events

An ADC conversion can be triggered automatically by an event input if the Start Event Input bit (STARTEI) in the Event Control register (ADCn.EVCTRL) is written to '1'.

See also the description of the Asynchronous User Channel n Input Selection in the Event System (EVSYS.ASYNCUSERn).

### Related Links

[14.5.5 ASYNCUSER](#)

### 30.3.4 Interrupts

**Table 30-2. Available Interrupt Vectors and Sources**

Offset	Name	Vector Description	Conditions
0x00	RESRDY	Result Ready interrupt	The conversion result is available in the Result register (ADC.RES).
0x02	WCOMP	Window Comparator interrupt	As defined by WINCM in ADC.CTRLA.

When an interrupt condition occurs, the corresponding interrupt flag is set in the Interrupt Flags register of the peripheral (*peripheral*.INTFLAGS).

An interrupt source is enabled or disabled by writing to the corresponding enable bit in the peripheral's Interrupt Control register (*peripheral*.INTCTRL).

An interrupt request is generated when the corresponding interrupt source is enabled and the interrupt flag is set. The interrupt request remains active until the interrupt flag is cleared. See the peripheral's INTFLAGS register for details on how to clear interrupt flags.

### 30.3.5 Sleep Mode Operation

The ADC is by default disabled in Standby Sleep mode.

The ADC can stay fully operational in Standby Sleep mode if the Run in Standby bit (RUNSTDBY) in the Control A register (ADC.CTRLA) is written to '1'.

When the device is entering Standby Sleep mode when RUNSTDBY is '1', the ADC will stay active, hence any ongoing conversions will be completed and interrupts will be executed as configured.

In Standby Sleep mode an ADC conversion must be triggered via the Event System (EVSYS), or the ADC must be in free-running mode with the first conversion triggered by software before entering sleep. The peripheral clock is requested if needed and is turned OFF after the conversion is completed.

When an input event trigger occurs, the positive edge will be detected, the Start Conversion bit (STCONV) in the Command register (ADC.COMMAND) will be set, and the conversion will start. When the conversion is completed, the Result Ready Flag (RESRDY) in the Interrupt Flags register (ADC.INTFLAGS) is set and the STCONV bit in ADC.COMMAND is cleared.

The reference source and supply infrastructure need time to stabilize when activated in Standby Sleep mode. Configure a delay for the start of the first conversion by writing a non-zero value to the Initial Delay bits (INITDLY) in the Control D register (ADC.CTRLD).

In Power-Down Sleep mode, no conversions are possible. Any ongoing conversions are halted and will be resumed when going out of sleep. At the end of the conversion, the Result Ready Flag (RESRDY) will be set, but the content of the result registers (ADC.RES) is invalid since the ADC was halted in the middle of a conversion.

#### Related Links

[11. SLPCTRL - Sleep Controller](#)

### 30.3.6 Synchronization

Not applicable.

### 30.3.7 Configuration Change Protection

Not applicable.

### 30.4 Register Summary - ADCn

Offset	Name	Bit Pos.								
0x00	CTRLA	7:0	RUNSTBY					RESSEL	FREERUN	ENABLE
0x01	CTRLB	7:0						SAMPNUM[2:0]		
0x02	CTRLC	7:0		SAMPCAP	REFSEL[1:0]			PRESC[2:0]		
0x03	CTRLD	7:0	INITDLY[2:0]		ASDV		SAMPDLY[3:0]			
0x04	CTRLE	7:0					WINCM[2:0]			
0x05	SAMPCTRL	7:0					SAMPLEN[4:0]			
0x06	MUXPOS	7:0					MUXPOS[4:0]			
0x07	Reserved									
0x08	COMMAND	7:0								STCONV
0x09	EVCTRL	7:0								STARTEI
0x0A	INTCTRL	7:0						WCOMP	RESRDY	
0x0B	INTFLAGS	7:0						WCOMP	RESRDY	
0x0C	DBGCTRL	7:0								DBGGRUN
0x0D	TEMP	7:0	TEMP[7:0]							
0x0E	Reserved									
...										
0x0F										
0x10	RES	7:0	RES[7:0]							
		15:8	RES[15:8]							
0x12	WINLT	7:0	WINLT[7:0]							
		15:8	WINLT[15:8]							
0x14	WINHT	7:0	WINHT[7:0]							
		15:8	WINHT[15:8]							
0x16	CALIB	7:0								DUTYCYC

### 30.5 Register Description

### 30.5.1 Control A

**Name:** CTRLA  
**Offset:** 0x00  
**Reset:** 0x00  
**Property:** -

	Bit	7	6	5	4	3	2	1	0
		RUNSTBY					RESSEL	FREERUN	ENABLE
Access		R/W					R/W	R/W	R/W
Reset		0					0	0	0

**Bit 7 – RUNSTBY** Run in Standby

This bit determines whether the ADC needs to run when the chip is in Standby Sleep mode.

**Bit 2 – RESSEL** Resolution Selection

This bit selects the ADC resolution.

Value	Description
0	Full 10-bit resolution. The 10-bit ADC results are accumulated or stored in the ADC Result register (ADC.RES).
1	8-bit resolution. The conversion results are truncated to eight bits (MSBs) before they are accumulated or stored in the ADC Result register (ADC.RES). The two Least Significant bits are discarded.

**Bit 1 – FREERUN** Free-Running

Writing a '1' to this bit will enable the Free-Running mode for the data acquisition. The first conversion is started by writing the STCONV bit in ADC.COMMAND high. In the Free-Running mode, a new conversion cycle is started immediately after or as soon as the previous conversion cycle has completed. This is signaled by the RESRDY flag in ADCn.INTFLAGS.

**Bit 0 – ENABLE** ADC Enable

Value	Description
0	ADC is disabled
1	ADC is enabled

### 30.5.2 Control B

**Name:** CTRLB  
**Offset:** 0x01  
**Reset:** 0x00  
**Property:** -

Bit	7	6	5	4	3	2	1	0
						SAMPNUM[2:0]		
Access						R/W	R/W	R/W
Reset						0	0	0

**Bits 2:0 – SAMPNUM[2:0]** Sample Accumulation Number Select

These bits select how many consecutive ADC sampling results are accumulated automatically. When this bit is written to a value greater than 0x0, the according number of consecutive ADC sampling results are accumulated into the ADC Result register (ADC.RES) in one complete conversion.

Value	Name	Description
0x0	NONE	No accumulation.
0x1	ACC2	2 results accumulated.
0x2	ACC4	4 results accumulated.
0x3	ACC8	8 results accumulated.
0x4	ACC16	16 results accumulated.
0x5	ACC32	32 results accumulated.
0x6	ACC64	64 results accumulated.
0x7	-	Reserved.



### 30.5.3 Control C

**Name:** CTRLC  
**Offset:** 0x02  
**Reset:** 0x00  
**Property:** -

Bit	7	6	5	4	3	2	1	0
		SAMPCAP	REFSEL[1:0]			PRESC[2:0]		
Access	R	R/W	R/W	R/W	R	R/W	R/W	R/W
Reset	0	0	0	0	0	0	0	0

#### Bit 6 – SAMPCAP Sample Capacitance Selection

This bit selects the sample capacitance, and hence, the input impedance. The best value is dependent on the reference voltage and the application's electrical properties.

Value	Description
0	Recommended for reference voltage values below 1V.
1	Reduced size of sampling capacitance. Recommended for higher reference voltages.

#### Bits 5:4 – REFSEL[1:0] Reference Selection

These bits select the voltage reference for the ADC.

**Note:** Do not force the internal reference enabled (ADCnREFEN=1 in VREF.CTRLB) when the ADC is using the external reference (REFSEL bits in ADC.CTRLC).

Value	Name	Description
0x0	INTERNAL	Internal reference
0x1	VDD	V <sub>DD</sub>
0x2	VREFA	External reference V <sub>REFA</sub>
Other	-	Reserved.

#### Bits 2:0 – PRESC[2:0] Prescaler

These bits define the division factor from the peripheral clock (CLK\_PER) to the ADC clock (CLK\_ADC).

Value	Name	Description
0x0	DIV2	CLK_PER divided by 2
0x1	DIV4	CLK_PER divided by 4
0x2	DIV8	CLK_PER divided by 8
0x3	DIV16	CLK_PER divided by 16
0x4	DIV32	CLK_PER divided by 32
0x5	DIV64	CLK_PER divided by 64
0x6	DIV128	CLK_PER divided by 128
0x7	DIV256	CLK_PER divided by 256

### 30.5.4 Control D

**Name:** CTRLD  
**Offset:** 0x03  
**Reset:** 0x00  
**Property:** -

Bit	7	6	5	4	3	2	1	0
	INITDLY[2:0]			ASDV	SAMPDLY[3:0]			
Access	R/W	R/W	R/W	R/W	R/W	R/W	R/W	R/W
Reset	0	0	0	0	0	0	0	0

#### Bits 7:5 – INITDLY[2:0] Initialization Delay

These bits define the initialization/start-up delay before the first sample when enabling the ADC or changing to an internal reference voltage. Setting this delay will ensure that the reference, MUXes, etc. are ready before starting the first conversion. The initialization delay will also take place when waking up from deep sleep to do a measurement.

The delay is expressed as a number of CLK\_ADC cycles.

Value	Name	Description
0x0	DLY0	Delay 0 CLK_ADC cycles.
0x1	DLY16	Delay 16 CLK_ADC cycles.
0x2	DLY32	Delay 32 CLK_ADC cycles.
0x3	DLY64	Delay 64 CLK_ADC cycles.
0x4	DLY128	Delay 128 CLK_ADC cycles.
0x5	DLY256	Delay 256 CLK_ADC cycles.
Other	-	Reserved

#### Bit 4 – ASDV Automatic Sampling Delay Variation

Writing this bit to '1' enables automatic sampling delay variation between ADC conversions. The purpose of varying sampling instant is to randomize the sampling instant and thus avoid standing frequency components in the frequency spectrum. The value of the SAMPDLY bits is automatically incremented by one after each sample.

When the Automatic Sampling Delay Variation is enabled and the SAMPDLY value reaches 0xF, it wraps around to 0x0.

Value	Name	Description
0	ASVOFF	The Automatic Sampling Delay Variation is disabled.
1	ASVON	The Automatic Sampling Delay Variation is enabled.

#### Bits 3:0 – SAMPDLY[3:0] Sampling Delay Selection

These bits define the delay between consecutive ADC samples. The programmable Sampling Delay allows modifying the sampling frequency during hardware accumulation, to suppress periodic noise sources that may otherwise disturb the sampling. The SAMPDLY field can also be modified automatically from one sampling cycle to another, by setting the ASDV bit. The delay is expressed as CLK\_ADC cycles and is given directly by the bit field setting. The sampling cap is kept open during the delay.

### 30.5.5 Control E

**Name:** CTRL E  
**Offset:** 0x4  
**Reset:** 0x00  
**Property:** -

Bit	7	6	5	4	3	2	1	0
						WINCM[2:0]		
Access						R/W	R/W	R/W
Reset						0	0	0

#### Bits 2:0 – WINCM[2:0] Window Comparator Mode

This field enables and defines when the interrupt flag is set in Window Comparator mode. RESULT is the 16-bit accumulator result. WINLT and WINHT are 16-bit lower threshold value and 16-bit higher threshold value, respectively.

Value	Name	Description
0x0	NONE	No Window Comparison (default)
0x1	BELOW	$RESULT < WINLT$
0x2	ABOVE	$RESULT > WINHT$
0x3	INSIDE	$WINLT < RESULT < WINHT$
0x4	OUTSIDE	$RESULT < WINLT$ or $RESULT > WINHT$
Other	-	Reserved

### 30.5.6 Sample Control

**Name:**       SAMPCTRL  
**Offset:**     0x5  
**Reset:**      0x00  
**Property:**   -

Bit	7	6	5	4	3	2	1	0
				SAMPLEN[4:0]				
Access				R/W	R/W	R/W	R/W	R/W
Reset				0	0	0	0	0

**Bits 4:0 – SAMPLEN[4:0]** Sample Length

These bits extend the ADC sampling length in a number of CLK\_ADC cycles. By default, the sampling time is two CLK\_ADC cycles. Increasing the sampling length allows sampling sources with higher impedance. The total conversion time increases with the selected sampling length.

### 30.5.7 MUXPOS

**Name:** MUXPOS  
**Offset:** 0x06  
**Reset:** 0x00  
**Property:** -

Bit	7	6	5	4	3	2	1	0
	MUXPOS[4:0]							
Access	R	R	R	R/W	R/W	R/W	R/W	R/W
Reset	0	0	0	0	0	0	0	0

#### Bits 4:0 – MUXPOS[4:0] MUXPOS

This bit field selects which single-ended analog input is connected to the ADC. If these bits are changed during a conversion, the change will not take effect until this conversion is complete.

Value	Name	Description
0x00	AIN0	ADC input pin 0
0x01	AIN1	ADC input pin 1
0x02	AIN2	ADC input pin 2
0x03	AIN3	ADC input pin 3
0x04	AIN4	ADC input pin 4
0x05	AIN5	ADC input pin 5
0x06	AIN6	ADC input pin 6
0x07	AIN7	ADC input pin 7
0x08	-	Reserved
0x09	-	Reserved
0x0A	AIN10	ADC input pin 10
0x0B	AIN11	ADC input pin 11
0x1B	PTC	ADC0: Reserved / ADC1: DAC2
0x1C	DAC0	DAC0
0x1D	INTREF	Internal reference (from VREF peripheral)
0x1F	GND	0V (GND)
Other	-	Reserved

**30.5.8 Command**

**Name:** COMMAND  
**Offset:** 0x08  
**Reset:** 0x00  
**Property:** -

	7	6	5	4	3	2	1	0
Bit								STCONV
Access	R	R	R	R	R	R	R	R/W
Reset	0	0	0	0	0	0	0	0

**Bit 0 – STCONV** Start Conversion

Writing a '1' to this bit will start a single measurement. If in Free-Running mode this will start the first conversion. STCONV will read as '1' as long as a conversion is in progress. When the conversion is complete, this bit is automatically cleared.

**30.5.9 Event Control**

**Name:** EVCTRL  
**Offset:** 0x09  
**Reset:** 0x00  
**Property:** -

Bit	7	6	5	4	3	2	1	0
								STARTEI
Access								R/W
Reset								0

**Bit 0 – STARTEI** Start Event Input

This bit enables using the event input as trigger for starting a conversion.

**30.5.10 Interrupt Control**

**Name:** INTCTRL  
**Offset:** 0x0A  
**Reset:** 0x00  
**Property:** -

	7	6	5	4	3	2	1	0
							WCOMP	RESRDY
Access							R/W	R/W
Reset							0	0

**Bit 1 – WCOMP** Window Comparator Interrupt Enable  
 Writing a '1' to this bit enables window comparator interrupt.

**Bit 0 – RESRDY** Result Ready Interrupt Enable  
 Writing a '1' to this bit enables result ready interrupt.



### 30.5.11 Interrupt Flags

**Name:** INTFLAGS  
**Offset:** 0x0B  
**Reset:** 0x00  
**Property:** -

	7	6	5	4	3	2	1	0
Bit							WCOMP	RESRDY
Access							R/W	R/W
Reset							0	0

**Bit 1 – WCOMP** Window Comparator Interrupt Flag

This window comparator flag is set when the measurement is complete and if the result matches the selected Window Comparator mode defined by WINCM (ADCn.CTRLB). The comparison is done at the end of the conversion. The flag is cleared by either writing a '1' to the bit position or by reading the Result register (ADCn.RES). Writing a '0' to this bit has no effect.

**Bit 0 – RESRDY** Result Ready Interrupt Flag

The result ready interrupt flag is set when a measurement is complete and a new result is ready. The flag is cleared by either writing a '1' to the bit location or by reading the Result register (ADCn.RES). Writing a '0' to this bit has no effect.

**30.5.12 Debug Run**

**Name:**     DBGCTRL  
**Offset:**    0x0C  
**Reset:**     0x00  
**Property:**  -

	7		6		5		4		3		2		1		0
	DBGRUN														
Access	R/W														
Reset	0														

**Bit 0 – DBGRUN** Debug Run

Value	Description
0	The peripheral is halted in Break Debug mode and ignores events
1	The peripheral will continue to run in Break Debug mode when the CPU is halted

### 30.5.13 Temporary

**Name:** TEMP  
**Offset:** 0x0D  
**Reset:** 0x00  
**Property:** -

The Temporary register is used by the CPU for single-cycle, 16-bit access to the 16-bit registers of this peripheral. It can be read and written by software. Refer to 16-bit access in the AVR CPU chapter. There is one common Temporary register for all the 16-bit registers of this peripheral.

Bit	7	6	5	4	3	2	1	0
	TEMP[7:0]							
Access	R/W	R/W	R/W	R/W	R/W	R/W	R/W	R/W
Reset	0	0	0	0	0	0	0	0

**Bits 7:0 – TEMP[7:0]** Temporary

Temporary register for read/write operations in 16-bit registers.

### 30.5.14 Result

**Name:** RES  
**Offset:** 0x10  
**Reset:** 0x00  
**Property:** -

The ADCn.RESL and ADCn.RESH register pair represents the 16-bit value, ADCn.RES. The low byte [7:0] (suffix L) is accessible at the original offset. The high byte [15:8] (suffix H) can be accessed at offset + 0x01.

If the analog input is higher than the reference level of the ADC, the 10-bit ADC result will be equal the maximum value of 0x3FF. Likewise, if the input is below 0V, the ADC result will be 0x000. As the ADC cannot produce a result above 0x3FF values, the accumulated value will never exceed 0xFFC0 even after the maximum allowed 64 accumulations.

	Bit	15	14	13	12	11	10	9	8
		RES[15:8]							
Access		R	R	R	R	R	R	R	R
Reset		0	0	0	0	0	0	0	0
	Bit	7	6	5	4	3	2	1	0
		RES[7:0]							
Access		R	R	R	R	R	R	R	R
Reset		0	0	0	0	0	0	0	0

#### Bits 15:8 – RES[15:8] Result high byte

These bits constitute the MSB of the ADCn.RES register, where the MSb is RES[15]. The ADC itself has a 10-bit output, ADC[9:0], where the MSb is ADC[9]. The data format in ADC and Digital Accumulation is 1's complement, where 0x0000 represents the '0' and 0xFFFF represents the largest number (full scale).

#### Bits 7:0 – RES[7:0] Result low byte

These bits constitute the LSB of ADC/Accumulator Result, (ADCn.RES) register. The data format in ADC and Digital Accumulation is 1's complement, where 0x0000 represents the '0' and 0xFFFF represents the largest number (full scale).

### 30.5.15 Window Comparator Low Threshold

**Name:** WINLT  
**Offset:** 0x12  
**Reset:** 0x00  
**Property:** -

This register is the 16-bit low threshold for the digital comparator monitoring the ADCn.RES register. The ADC itself has a 10-bit output, RES[9:0], where the MSb is RES[9]. The data format in ADC and Digital Accumulation is 1's complement, where 0x0000 represents the '0' and 0xFFFF represents the largest number (full scale).

The ADCn.WINLTH and ADCn.WINLTL register pair represents the 16-bit value, ADCn.WINLT. The low byte [7:0] (suffix L) is accessible at the original offset. The high byte [15:8] (suffix H) can be accessed at offset + 0x01.

When accumulating samples, the window comparator thresholds are applied to the accumulated value and not on each sample.

Bit	15	14	13	12	11	10	9	8
	WINLT[15:8]							
Access	R/W	R/W	R/W	R/W	R/W	R/W	R/W	R/W
Reset	0	0	0	0	0	0	0	0
Bit	7	6	5	4	3	2	1	0
	WINLT[7:0]							
Access	R/W	R/W	R/W	R/W	R/W	R/W	R/W	R/W
Reset	0	0	0	0	0	0	0	0

**Bits 15:8 – WINLT[15:8]** Window Comparator Low Threshold High Byte  
 These bits hold the MSB of the 16-bit register.

**Bits 7:0 – WINLT[7:0]** Window Comparator Low Threshold Low Byte  
 These bits hold the LSB of the 16-bit register.

### 30.5.16 Window Comparator High Threshold

**Name:** WINHT  
**Offset:** 0x14  
**Reset:** 0x00  
**Property:** -

This register is the 16-bit high threshold for the digital comparator monitoring the ADCn.RES register. The ADC itself has a 10-bit output, RES[9:0], where the MSb is RES[9]. The data format in ADC and Digital Accumulation is 1's complement, where 0x0000 represents the '0' and 0xFFFF represents the largest number (full scale).

The ADCn.WINHTH and ADCn.WINHTL register pair represents the 16-bit value, ADCn.WINHT. The low byte [7:0] (suffix L) is accessible at the original offset. The high byte [15:8] (suffix H) can be accessed at offset + 0x01.

Bit	15	14	13	12	11	10	9	8
	WINHT[15:8]							
Access	R/W	R/W	R/W	R/W	R/W	R/W	R/W	R/W
Reset	0	0	0	0	0	0	0	0
Bit	7	6	5	4	3	2	1	0
	WINHT[7:0]							
Access	R/W	R/W	R/W	R/W	R/W	R/W	R/W	R/W
Reset	0	0	0	0	0	0	0	0

**Bits 15:8 – WINHT[15:8]** Window Comparator High Threshold High Byte  
 These bits hold the MSB of the 16-bit register.

**Bits 7:0 – WINHT[7:0]** Window Comparator High Threshold Low Byte  
 These bits hold the LSB of the 16-bit register.

### 30.5.17 Calibration

**Name:** CALIB  
**Offset:** 0x16  
**Reset:** 0x01  
**Property:** -

	7	6	5	4	3	2	1	0	
							DUTYCYC		
Access							R/W	R/W	R/W
Reset							0	0	1

**Bit 0 – DUTYCYC** Duty Cycle

This bit determines the duty cycle of the ADC clock.

ADC<sub>clk</sub> > 1.5 MHz requires a minimum operating voltage of 2.7V

Value	Description
0	50% Duty Cycle must be used if ADC <sub>clk</sub> > 1.5 MHz
1	25% Duty Cycle (high 25% and low 75%) must be used for ADC <sub>clk</sub> ≤ 1.5 MHz

## 31. DAC - Digital-to-Analog Converter

### 31.1 Features

- 8-bit Resolution
- Up to 350 ksps Conversion Rate
- High Drive Capabilities (DAC0)
- Functioning as Input to Analog Comparator (AC) or ADC
- Three Instances of the Peripheral: DAC0, DAC1, DAC2

### 31.2 Overview

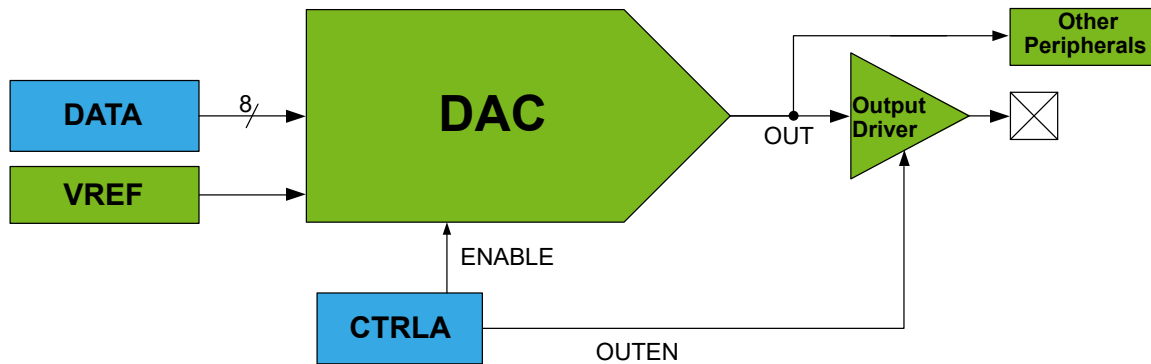
The Digital-to-Analog Converter (DAC) converts a digital value written to the Data register (DAC.DATA) to an analog voltage. The conversion range is between GND and the selected reference voltage.

The DAC features an 8-bit resistor-string type DAC, capable of converting 350,000 samples per second (350 ksps). The DAC uses the internal Voltage Reference (VREF) as the upper limit for conversion. The DAC has one continuous time output with high drive capabilities, which is able to drive 5 kΩ and/or 30 pF load. The DAC conversion can be started from the application by writing to the Data Conversion registers.

This device has three instances of the DAC peripheral, DAC0, DAC1, and DAC2.

#### 31.2.1 Block Diagram

Figure 31-1. DAC Block Diagram



**Note:** Only DAC0 has an output driver for an external pin.

#### 31.2.2 Signal Description

Signal	Description	Type
OUT	DAC output	Analog

**Note:** Only DAC0 has an output driver for an external pin.

#### Related Links

[5. I/O Multiplexing and Considerations](#)



### 31.2.3 System Dependencies

In order to use this peripheral, other parts of the system must be configured correctly, as described below.

**Table 31-1. DAC System Dependencies**

Dependency	Applicable	Peripheral
Clocks	Yes	CLKCTRL
I/O Lines and Connections	Yes	PORT
Interrupts	No	-
Events	No	-
Debug	Yes	UPDI

#### Related Links

[11.2.2.1 Clocks](#)

[31.2.3.2 I/O Lines and Connections](#)

[31.2.3.5 Debug Operation](#)

#### 31.2.3.1 Clocks

This peripheral depends on the peripheral clock.

#### Related Links

[10. CLKCTRL - Clock Controller](#)

#### 31.2.3.2 I/O Lines and Connections

Using the I/O lines of the peripheral requires configuration of the I/O pins.

**Table 31-2. I/O Lines**

Instance	Signal	I/O Line	Peripheral Function
DAC0	OUT	PA6	A

The DAC0 has one analog output pin (OUT) that must be configured before it can be used.

A DAC is also internally connected to the AC and to the ADC. To use this internal OUT as input, both output and input must be configured in their respective registers.

**Note:** Only DAC0 has an output driver for an external pin.

#### Related Links

[16. PORT - I/O Pin Configuration](#)

[29. AC - Analog Comparator](#)

[30. ADC - Analog-to-Digital Converter](#)

#### 31.2.3.3 Events

Not applicable.

#### 31.2.3.4 Interrupts

Not applicable.

#### 31.2.3.5 Debug Operation

This peripheral is unaffected by entering Debug mode.

If the peripheral is configured to require periodical service by the CPU through interrupts or similar, improper operation or data loss may result during halted debugging.

### Related Links

[16. PORT - I/O Pin Configuration](#)

## 31.3 Functional Description

### 31.3.1 Initialization

To operate the DAC, the following steps are required:

- Select the DAC reference voltage in the Voltage Reference (VREF) peripheral by writing the DAC and AC Reference Selection bits (DAC0REFSEL) in the Control A register of the Voltage Reference (VREF.CTRLA) for DAC0. For DAC1, use DAC1REFSEL in VREF.CTRLB. For DAC2, use DAC2REFSEL in VREF.CTRLD.
- The conversion range is between GND and the selected reference voltage.
- Configure the further usage of the DAC output:
  - Configure an internal peripheral (e.g. AC, ADC) to use the DAC output. See the according peripheral's documentation.
  - Enable the output to a pin by writing a '1' to the Output Enable bit (OUTEN) in the Control A register (DAC.CTRLA). This requires configuration of the Port peripheral.

For DAC0, either one or both options are valid. Other instances of the DAC only support internal signaling.

- Write an initial digital value to the Data register (DAC.DATA).
- Enable the DAC by writing a '1' to the ENABLE bit in the Control A register (DAC.CTRLA).

### Related Links

[18. VREF - Voltage Reference](#)

[29. AC - Analog Comparator](#)

[30. ADC - Analog-to-Digital Converter](#)

### 31.3.2 Operation

#### 31.3.2.1 Enabling, Disabling, and Resetting

The DAC is enabled by writing a '1' to the ENABLE bit in the Control A register (DACn.CTRLA), and disabled by writing a '0' to this bit.

The OUT output to a pin is enabled by writing the Output Enable bit (OUTEN) in the CTRLA register (DACn.CTRLA).

#### 31.3.2.2 Starting a Conversion

When the DAC is enabled (ENABLE=1 in DACn.CTRLA), a conversion starts as soon as the Data register (DACn.DATA) is written.

When the DAC is disabled (ENABLE=0 in DACn.CTRLA), writing DACn.DATA does not trigger a conversion. Instead, the conversion starts on writing a '1' to ENABLE in DACn.CTRLA.

#### 31.3.2.3 DAC as Source For Internal Peripherals

The analog output of the DAC is internally connected to both the AC and the ADC and is available to these other peripherals when the DAC is enabled (ENABLE=1 in DAC.CTRLA). When the DAC analog

output is only being used internally, it is not necessary to enable the pin output driver (i.e. OUTEN=0 in DAC.CTRLA is acceptable).

**Note:** Only DAC0 has an output driver for an external pin.

### Related Links

[29. AC - Analog Comparator](#)

[30. ADC - Analog-to-Digital Converter](#)

### 31.3.3 Sleep Mode Operation

If the Run in Standby bit (RUNSTDBY) in the Control A register (DAC.CTRLA) is written to '1' and CLK\_PER is available, the DAC will continue to operate in Standby Sleep mode. If RUNSTDBY bit is '0', the DAC will stop the conversion in Standby Sleep mode.

If the conversion is stopped in Standby Sleep mode, the DAC and the output buffer are disabled to reduce power consumption. When the device is exiting Standby Sleep mode, the DAC and the output buffer (if configured by OUTEN=1 in DAC.CTRLA) are enabled again. Therefore, a certain start-up time is required before a new conversion is initiated.

In Power-Down Sleep mode, the DAC and output buffer are disabled to reduce the power consumption.

**Note:** Only DAC0 has an output driver for an external pin.

### 31.3.4 Configuration Change Protection

Not applicable.

### 31.4 Register Summary - DAC

Offset	Name	Bit Pos.								
0x00	CTRLA	7:0	RUNSTDBY	OUTEN						ENABLE
0x01	DATA	7:0	DATA[7:0]							

### 31.5 Register Description

### 31.5.1 Control A

**Name:** CTRLA  
**Offset:** 0x00  
**Reset:** 0x00  
**Property:** -

	7	6	5	4	3	2	1	0
	RUNSTDBY	OUTEN						ENABLE
Access	R/W	R/W						R/W
Reset	0	0						0

**Bit 7 – RUNSTDBY** Run in Standby Mode

If this bit is written to '1', the DAC or output buffer will not automatically be disabled when the device is entering Standby Sleep mode.

**Note:** Only DAC0 has an output driver for an external pin.

**Bit 6 – OUTEN** Output Buffer Enable

Writing a '1' to this bit enables the output buffer and sends the OUT signal to a pin.

**Note:** Only DAC0 has an output driver for an external pin.

**Bit 0 – ENABLE** DAC Enable

Writing a '1' to this bit enables the DAC.

**31.5.2 DATA**

**Name:** DATA  
**Offset:** 0x01  
**Reset:** 0x00  
**Property:** -

Bit	7	6	5	4	3	2	1	0
	DATA[7:0]							
Access	R/W	R/W	R/W	R/W	R/W	R/W	R/W	R/W
Reset	0	0	0	0	0	0	0	0

**Bits 7:0 – DATA[7:0] Data**

These bits contain the digital data, which will be converted to an analog voltage.

## 32. Peripheral Touch Controller (PTC)

### 32.1 Overview

The Peripheral Touch Controller (PTC) acquires signals in order to detect a touch on the capacitive sensors. The external capacitive touch sensor is typically formed on a PCB, and the sensor electrodes are connected to the analog front end of the PTC through the I/O pins in the device. The PTC supports both self and mutual capacitance sensors.

In the Mutual Capacitance mode, sensing is done using capacitive touch matrices in various X-Y configurations, including indium tin oxide (ITO) sensor grids. The PTC requires one pin per X-line and one pin per Y-line.

In the Self Capacitance mode, the PTC requires only one pin (Y-line) for each touch sensor.

The number of available pins and the assignment of X- and Y-lines is depending on both package type and device configuration. Refer to the Configuration Summary and I/O Multiplexing table for details.

#### Related Links

- [1.1 Configuration Summary](#)
- [5. I/O Multiplexing and Considerations](#)

### 32.2 Features

- Low-Power, High-Sensitivity, Environmentally Robust Capacitive Touch Buttons, Sliders, and Wheels
- Supports Wake-up on Touch from power-save Sleep mode
- Supports Mutual Capacitance and Self Capacitance Sensing
  - Mix-and-Match Mutual and Self Capacitance Sensors
- One Pin per Electrode – No External Components
- Load Compensating Charge Sensing
  - Parasitic capacitance compensation and adjustable gain for superior sensitivity
- Zero Drift Over the Temperature and  $V_{DD}$  Range
  - Auto calibration and recalibration of sensors
- Single-shot and free-running Charge Measurement
- Hardware Noise Filtering and Noise Signal Desynchronization for High Conducted Immunity
- Driven Shield for Better Noise Immunity and Moisture Tolerance
  - Any PTC X/Y line can be used for the driven shield
  - All enabled sensors will be driven at the same potential as the sensor scanned
- Selectable channel change delay allows choosing the settling time on a new channel, as required
- Acquisition-start triggered by command or through auto-triggering feature
- Low CPU utilization through interrupt on acquisition-complete
- Using ADC peripheral for signal conversion and acquisition

#### Related Links

- [1.1 Configuration Summary](#)
- [5. I/O Multiplexing and Considerations](#)

### 32.3 Block Diagram

Figure 32-1. PTC Block Diagram Mutual Capacitance

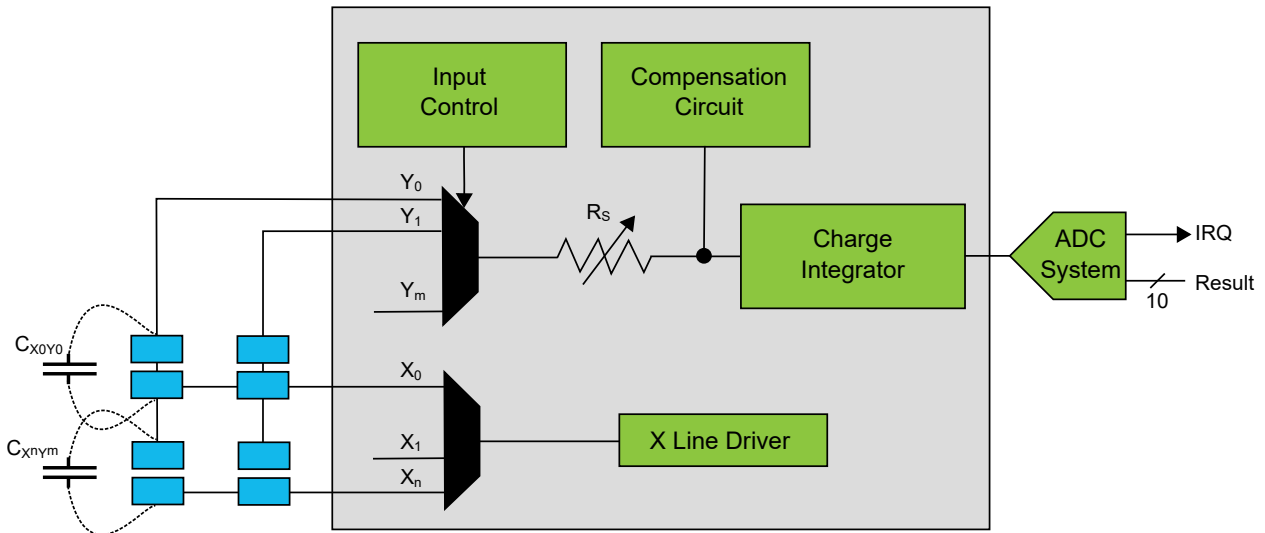
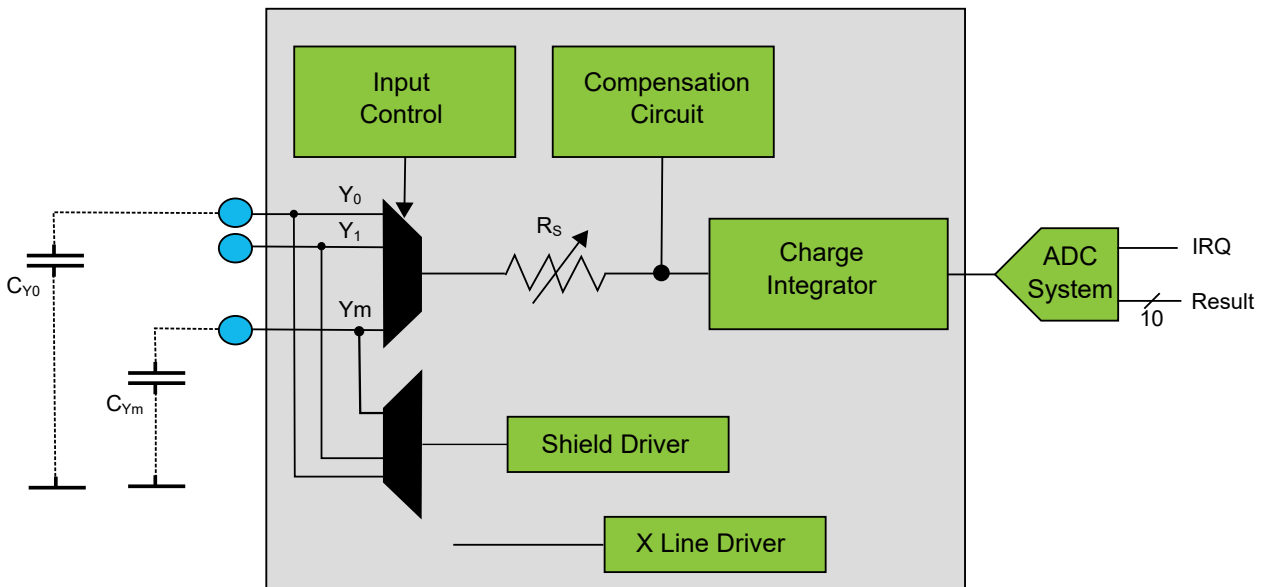


Figure 32-2. PTC Block Diagram Self Capacitance



### 32.4 Signal Description

Table 32-1. Signal Description for PTC

Name	Type	Description
Y[m:0]	Analog	Y-line (Input/Output)
X[n:0]	Digital	X-line (Output)

**Note:** The number of X- and Y-lines are device dependent. Refer to *Configuration Summary* for details.



Refer to *I/O Multiplexing and Considerations* for details on the pin mapping for this peripheral. One signal can be mapped on several pins.

### Related Links

- [1.1 Configuration Summary](#)
- [5. I/O Multiplexing and Considerations](#)

## 32.5 System Dependencies

In order to use this peripheral, configure the other components of the system as described in the following sections.

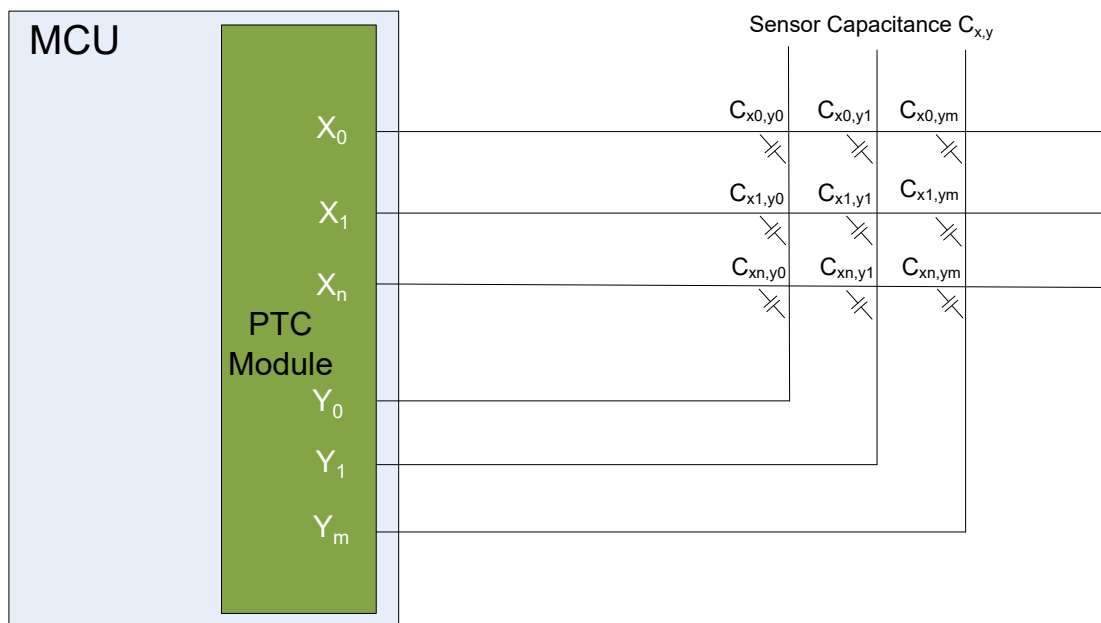
### 32.5.1 I/O Lines

The I/O lines used for analog X-lines and Y-lines must be connected to external capacitive touch sensor electrodes. External components are not required for normal operation. However, to improve the EMC performance, a series resistor of 1 kΩ or more can be used on X-lines and Y-lines.

#### 32.5.1.1 Mutual Capacitance Sensor Arrangement

A mutual capacitance sensor is formed between two I/O lines - an X electrode for transmitting and Y electrode for sensing. The mutual capacitance between the X and Y electrode is measured by the peripheral touch controller.

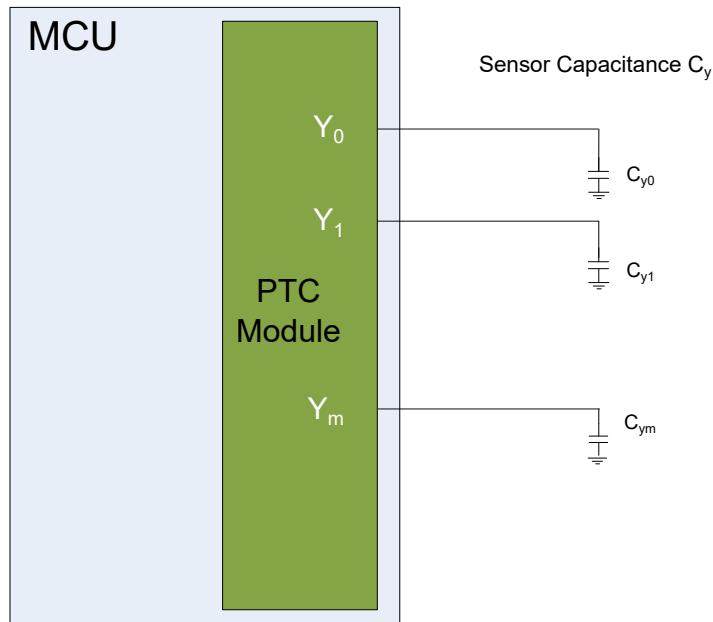
**Figure 32-3. Mutual Capacitance Sensor Arrangement**



#### 32.5.1.2 Self Capacitance Sensor Arrangement

A self capacitance sensor is connected to a single pin on the peripheral touch controller through the Y electrode for sensing the signal. The sense electrode capacitance is measured by the peripheral touch controller.

**Figure 32-4. Self-Capacitance Sensor Arrangement**



For more information about designing the touch sensor, refer to [Buttons, Sliders and Wheels Touch Sensor Design Guide](#).

### 32.5.2 Clocks

The PTC is clocked by the CLK\_PER clock. See the Related Links for details on configuring CLK\_PER.

#### Related Links

[10. CLKCTRL - Clock Controller](#)

### 32.5.3 Analog-Digital Converter (ADC)

The PTC is using the ADC for signal conversion and acquisition. The ADC must be enabled and configured appropriately to allow correct behavior of the PTC.

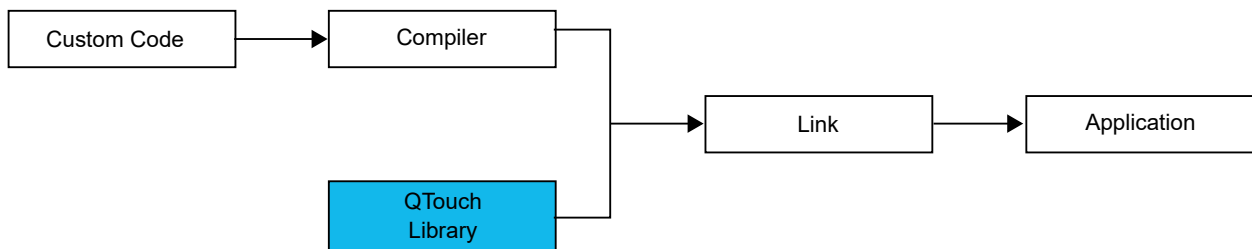
#### Related Links

[30. ADC - Analog-to-Digital Converter](#)

## 32.6 Functional Description

In order to access the PTC, the user must use the Atmel Start QTouch<sup>®</sup> Configurator to configure and link the QTouch Library firmware with the application software. QTouch Library can be used to implement buttons, sliders, and wheels in a variety of combinations on a single interface.

**Figure 32-5. QTouch Library Usage**



# ATtiny1614

## Peripheral Touch Controller (PTC)

---

For more information about QTouch Library, refer to the [QTouch Library Peripheral Touch Controller User Guide](#).

## 33. UPDI - Unified Program and Debug Interface

### 33.1 Features

- Programming:
  - External programming through UPDI 1-wire (1W) interface
    - Enable programming by 12V or fuse
    - Uses the  $\overline{\text{RESET}}$  pin of the device for programming
    - No GPIO pins occupied during operation
    - Asynchronous Half-Duplex UART protocol towards the programmer
- Debugging:
  - Memory mapped access to device address space (NVM, RAM, I/O)
  - No limitation on device clock frequency
  - Unlimited number of user program breakpoints
  - Two hardware breakpoints
  - Run-time readout of CPU Program Counter (PC), Stack Pointer (SP), and Status register (SREG) for code profiling
  - Program flow control
    - Go, Stop, Reset, Step Into
  - Non-intrusive run-time chip monitoring without accessing system registers
    - Monitor CRC status and sleep status
- Unified Programming and Debug Interface (UPDI):
  - Built-in error detection with error signature readout
  - Frequency measurement of internal oscillators using the Event System

### 33.2 Overview

The Unified Program and Debug Interface (UPDI) is a proprietary interface for external programming and on-chip debugging of a device.

The UPDI supports programming of nonvolatile memory (NVM) space; FLASH, EEPROM, fuses, lockbits, and the user row. In addition, the UPDI can access the entire I/O and data space of the device. See the NVM controller documentation for programming via the NVM controller and executing NVM controller commands.

Programming and debugging are done through the UPDI Physical interface (UPDI PHY), which is a 1-wire UART-based half duplex interface using the  $\overline{\text{RESET}}$  pin for data reception and transmission. Clocking of UPDI PHY is done by an internal oscillator. Enabling of the 1-wire interface, by disabling the Reset functionality, is either done by 12V programming or by fusing the  $\overline{\text{RESET}}$  pin to UPDI by setting the  $\overline{\text{RESET}}$  Pin Configuration (RSTPINCFG) bits in FUSE.SYSCFG0. The UPDI access layer grants access to the bus matrix, with memory mapped access to system blocks such as memories, NVM, and peripherals.

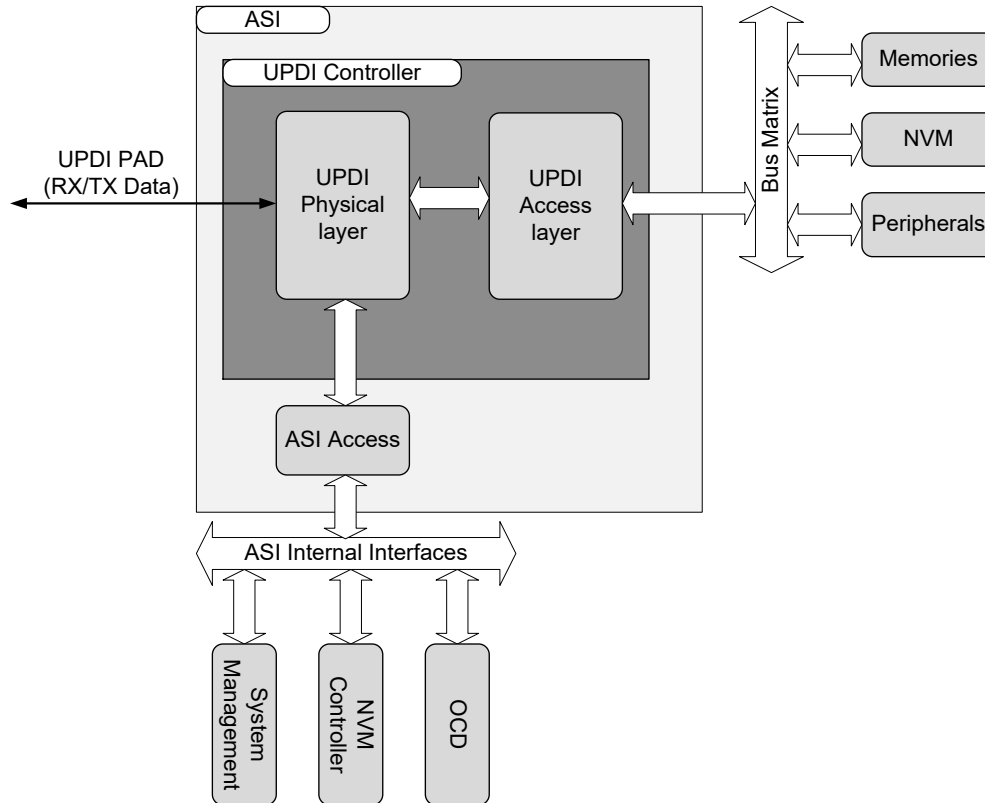
The Asynchronous System Interface (ASI) provides direct interface access to On-Chip Debugging (OCD), NVM, and System Management features. This gives the debugger direct access to system information, without requesting bus access.

### Related Links

- [9. NVMCTRL - Nonvolatile Memory Controller](#)
- [33.3.7 Enabling of KEY Protected Interfaces](#)

### 33.2.1 Block Diagram

Figure 33-1. UPDI Block Diagram



### 33.2.2 System Dependencies

In order to use this peripheral, other parts of the system must be configured correctly, as described below.

Table 33-1. UPDI System Dependencies

Dependency	Applicable	Peripheral
Clocks	Yes	CLKCTRL
I/O Lines and Connections	Yes	PORT
Interrupts	No	-
Events	Yes	EVSYS
Debug	Yes	UPDI

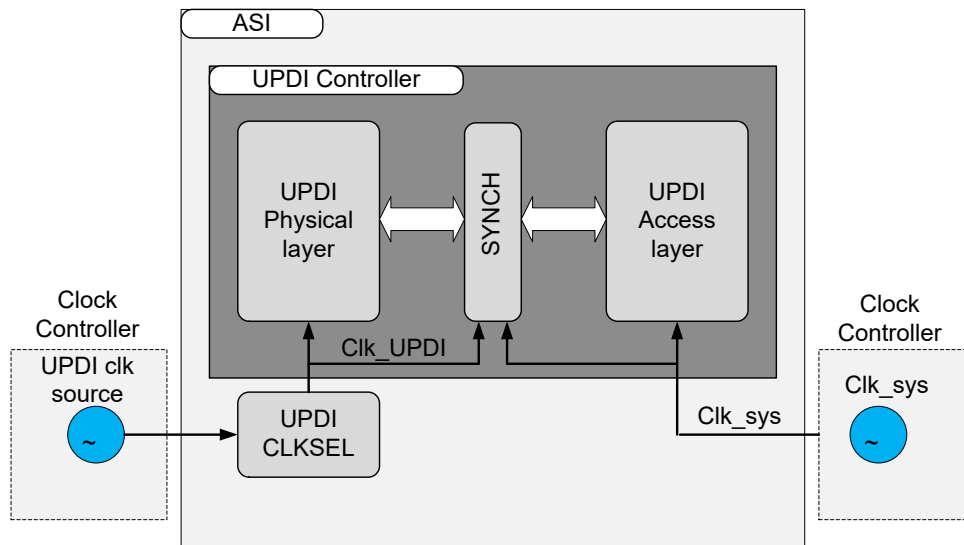
### Related Links

- [33.2.2.2 I/O Lines and Connections](#)
- [33.2.2.4 Power Management](#)

### 33.2.2.1 Clocks

The UPDI Physical (UPDI PHY) layer and UPDI Access (UPDI ACC) layer can operate on different clock domains. The UPDI PHY layer clock is derived from an internal oscillator, and the UPDI ACC layer clock is the same as the system clock. There is a synchronization boundary between the UPDI PHY layer and the UPDI ACC layer, which ensures correct operation between the clock domains. The UPDI clock output frequency is selected through the ASI, and the default UPDI clock start-up frequency is 4 MHz after enabling the UPDI. The UPDI clock frequency is changed by writing the UPDI<sub>CLKSEL</sub> bits in the ASI\_CTRLA register.

**Figure 33-2. UPDI Clock Domains**



#### Related Links

[10. CLKCTRL - Clock Controller](#)

### 33.2.2.2 I/O Lines and Connections

To operate the UPDI, the  $\overline{\text{RESET}}$  pin must be set to UPDI mode. This is not done through the port I/O pin configuration as regular I/O pins, but through setting the  $\overline{\text{RESET}}$  Pin Configuration (RSTPINCFG) bits in FUSE.SYSCFG0, as described in [33.3.2.1 UPDI Enable with Fuse Override of RESET Pin](#), or by following the UPDI 12V enable sequence from [33.3.2.2 UPDI Enable with 12V Override of RESET Pin](#). Pull enable, input enable, and output enable settings are automatically controlled by the UPDI when active.

### 33.2.2.3 Events

The events of this peripheral are connected to the Event System.

#### Related Links

[14. EVSYS - Event System](#)

### 33.2.2.4 Power Management

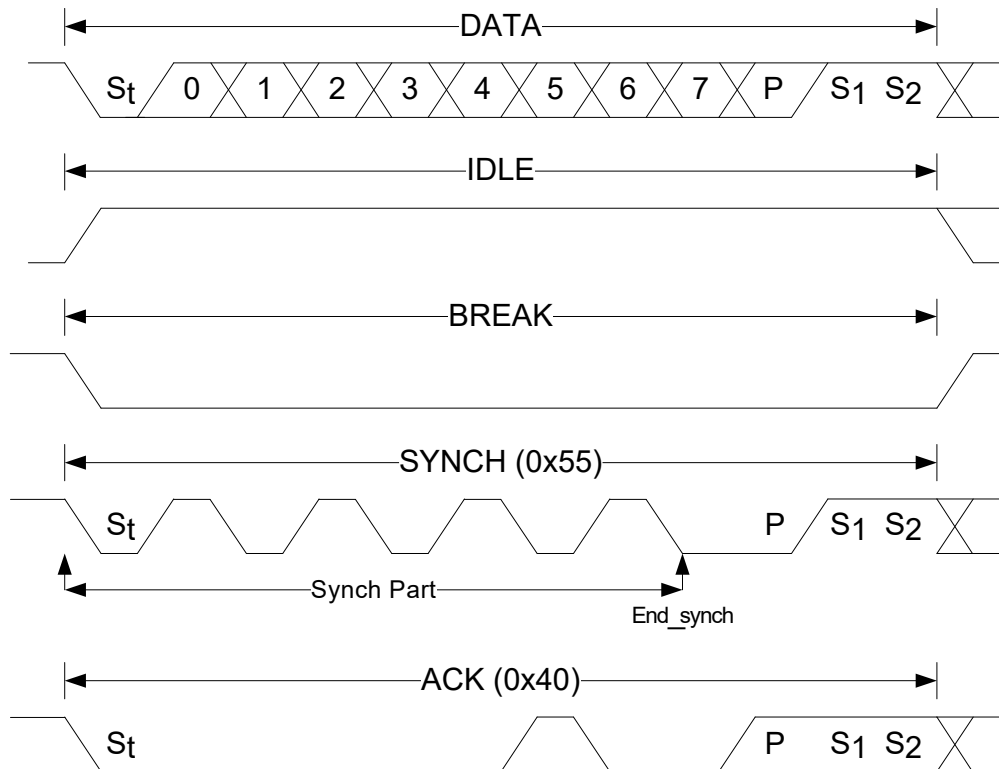
The UPDI physical layer continues to operate in any Sleep mode and is always accessible for a connected debugger, but read/write access to the system bus is restricted in Sleep modes where the CPU clock is switched OFF. The UPDI can be enabled at any time, independent of the system Sleep state. See [33.3.9 Sleep Mode Operation](#) for details on UPDI operation during Sleep modes.

### 33.3 Functional Description

#### 33.3.1 Principle of Operation

Communication through the UPDI is based on standard UART communication, using a fixed frame format, and automatic baud rate detection for clock and data recovery. In addition to the data frame, there are several control frames which are important to the communication. The supported frame formats are presented in [Figure 33-3](#).

**Figure 33-3. Supported UPDI Frame Formats**



**Data Frame** Data frame consists of one Start bit (always low), eight data bits, one parity bit (even parity), and two Stop bits (always high). If the Start bit, parity bit, or Stop bits have an incorrect value, an error will be detected and signaled by the UPDI. The parity bit-check in the UPDI can be disabled by writing the PARD bit in UPDI.CTRLA, in which case the parity generation from the debugger can be ignored.

**IDLE Frame** Special frame that consists of 12 high bits. This is the same as keeping the transmission line in an Idle state.

**BREAK** Special frame that consists of 12 low bits. The BREAK frame is used to reset the UPDI back to its default state and is typically used for error recovery.

**SYNCH** The SYNCH frame (0x55) is used by the Baud Rate Generator to set the baud rate for the coming transmission. A SYNCH character is always expected by the UPDI in front of every new instruction, and after a successful BREAK has been transmitted.

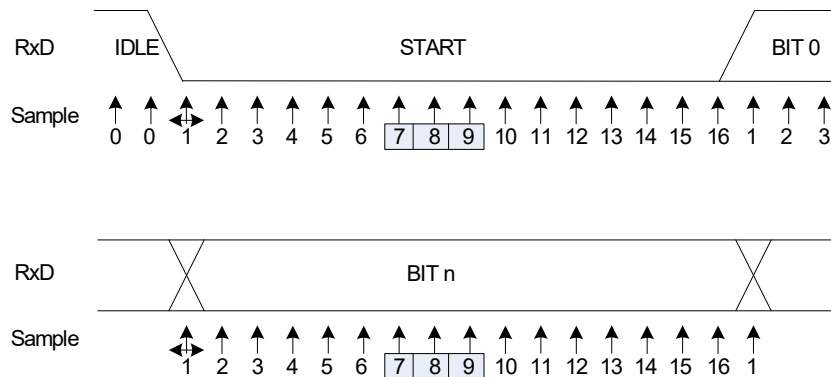
**ACK** The Acknowledge (ACK) character is transmitted from the UPDI whenever an ST or STS instruction has successfully crossed the synchronization boundary and have gained bus access. When an ACK is received by the debugger, the next transmission can start.

### 33.3.1.1 UPDI UART

All transmission and reception of serial data on the UPDI is achieved using the UPDI frames presented in [Figure 33-3](#). Communication is initiated from the master (debugger) side, and every transmission must start with a SYNCH character upon which the UPDI can recover the transmission baud rate, and store this setting for the coming data. The baud rate set by the SYNCH character will be used for both reception and transmission for the instruction byte received after the SYNCH. See [33.3.3 UPDI Instruction Set](#) for details on when the next SYNCH character is expected in the instruction stream.

There is no writable baud rate register in the UPDI, so the baud rate sampled from the SYNCH character is used for data recovery by sampling the Start bit, and performing a majority vote on the middle samples. This process is repeated for all bits in the frame, including the parity bit and two Stop bits. The baud generator uses 16 samples, and the majority voting is done on sample 7, 8, and 9.

**Figure 33-4. UPDI UART Start Bit and Data/Parity/Stop Bit Sampling**



The transmission baud rate must be set up in relation to the selected UPDI clock, which can be adjusted by UPDICKSEL in UPDI.ASI\_CTRLA. See [Table 33-2](#) for recommended maximum and minimum baud rate settings.

**Table 33-2. Recommended UART Baud Rate Based on UPDICKSEL Setting**

UPDICKSEL[1:0]	MAX Recommended Baud Rate	MIN Recommended Baud Rate
0x1 (16 MHz)	0.9 Mbps	0.300 kbps
0x2 (8 MHz)	450 kbps	0.150 kbps
0x3 (4 MHz) - Default	225 kbps	0.075 kbps

The UPDI Baud Rate Generator utilizes fractional baud counting to minimize the transmission error. With the fixed frame format used by the UPDI, the maximum and recommended receiver transmission error limits can be seen in the following table:

**Table 33-3. Receiver Baud Rate Error**

Data + Parity Bits	$R_{slow}$	$R_{fast}$	Max. Total Error [%]	Recommended Max. RX Error [%]
9	96.39	104.76	+4.76/-3.61	+1.5/-1.5

### 33.3.1.2 BREAK Character

The BREAK character is used to reset the internal state of the UPDI to the default setting. This is useful if the UPDI enters an error state due to a communication error, or when the synchronization between the debugger and the UPDI is lost.



A single BREAK character is enough to reset the UPDI, but in some special cases where the BREAK character is sent when the UPDI has not yet entered the error state, a double BREAK character might be needed. A double BREAK is ensured to reset the UPDI from any state. When sending a double BREAK it is required to have at least one Stop bit between the BREAK characters.

No SYNCH character is required before the BREAK because the BREAK is used to reset the UPDI from any state. This means that the UPDI will sample the BREAK based on the last stored baud rate setting, derived from the last received valid SYNCH character. If the communication error was due to an incorrect sampling of the SYNCH character, the baud rate is unknown to the connected debugger. For this reason, the BREAK character should be transmitted at the slowest recommended baud rate setting for the selected UPDI clock according to [Table 33-4](#):

**Table 33-4. Recommended BREAK Character Duration**

UPDICKSEL[1:0]	Recommended BREAK Character Duration
0x1 (16 MHz)	6.15 ms
0x2 (8 MHz)	12.30 ms
0x3 (4 MHz) - Default	24.60 ms

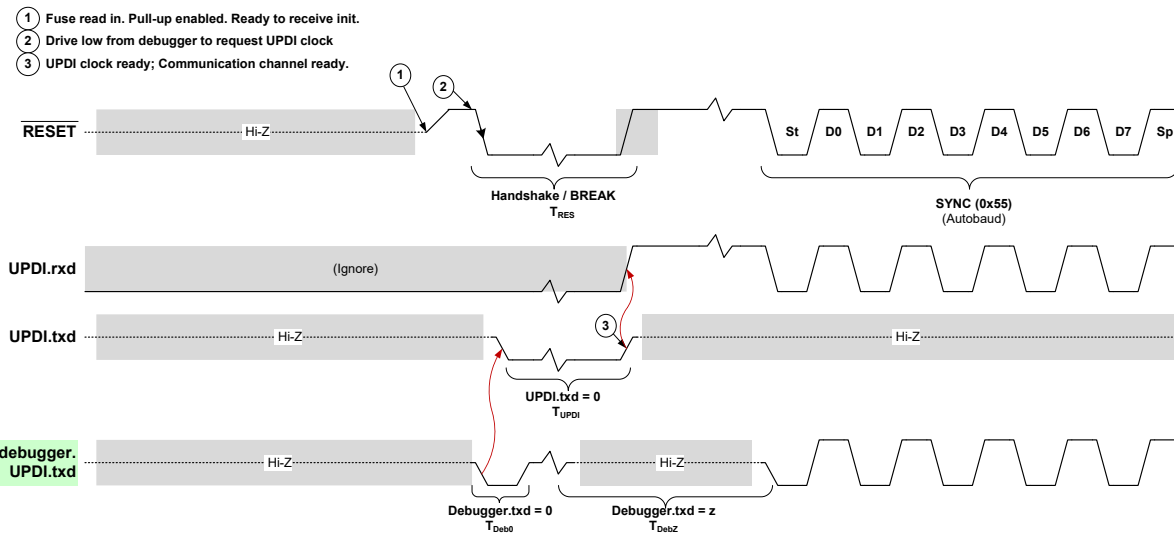
### 33.3.2 Operation

The UPDI must be enabled before the UART communication can start.

#### 33.3.2.1 UPDI Enable with Fuse Override of RESET Pin

When the RESET Pin Configuration (RSTPINCFG) bits in FUSE.SYSCFG0 are 0x1, the RESET pin will be overridden, and the UPDI will take control of the pin and configure it as input with pull-up. When the pull-up is detected by a connected debugger, the UPDI enable sequence, as depicted below, is started.

**Figure 33-5. UPDI Enable Sequence with UPDI PAD Enabled By Fuse**



When the pull-up is detected, the debugger initiates the enable sequence by driving the line low for a duration of  $T_{Deb0}$  to ensure that the line is released from the debugger before the UPDI enable sequence is done.

The negative edge is detected by the UPDI, which requests the UPDI clock. The UPDI will continue to drive the line low until the clock is stable and ready for the UPDI to use. The duration of this  $T_{UPDI}$  will

vary, depending on the status of the oscillator when the UPDI is enabled. After this duration, the data line will be released by the UPDI and pulled high.

When the debugger detects that the line is high, the initial SYNCH character (0x55) must be sent to properly enable the UPDI for communication. If the Start bit of the SYNCH character is not sent well within maximum  $T_{DebZ}$ , the UPDI will disable itself, and the enable sequence must be repeated. This time is based on counted cycles on the 4 MHz UPDI clock, which is the default when enabling the UPDI. The disable is performed to avoid the UPDI being enabled unintentionally.

After successful SYNCH character transmission, the first instruction frame can be transmitted.

### Related Links

[37.19 UPDI Timing](#)

[37.19 UPDI Timing](#)

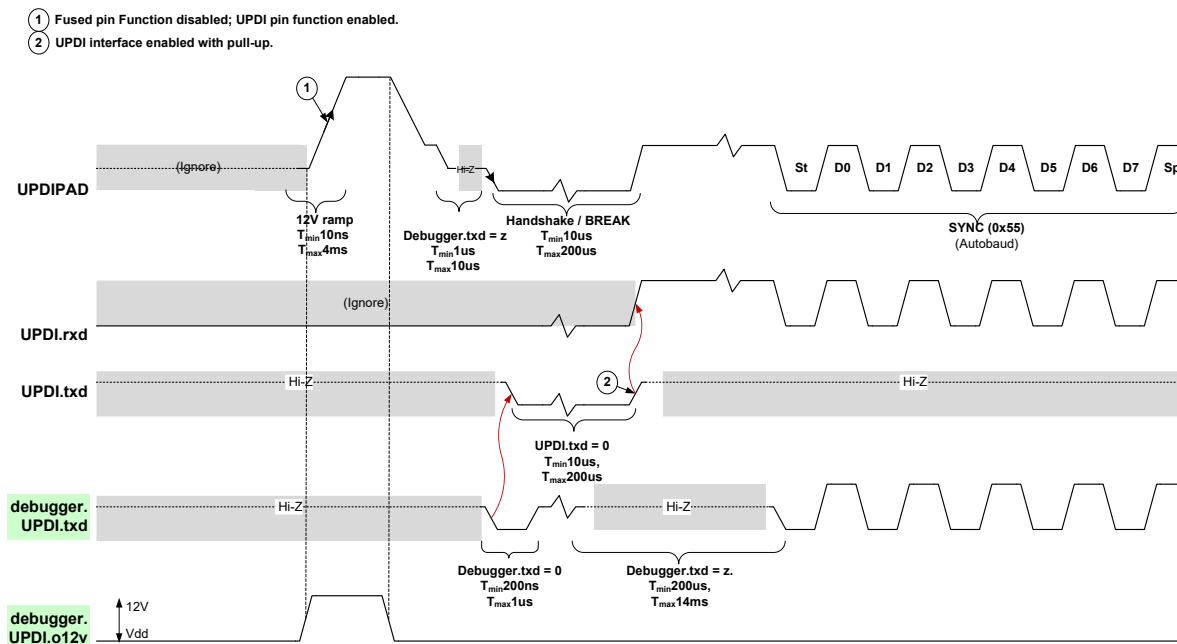
### 33.3.2.2 UPDI Enable with 12V Override of $\overline{\text{RESET}}$ Pin

GPIO or Reset functionality on the  $\overline{\text{RESET}}$  pin can be overridden by the UPDI by using 12V programming. By applying a 12V pulse to the  $\overline{\text{RESET}}$  pin, the pin functionality is switched to UPDI, independent of RSTPINCFG in FUSE.SYSCFG0. It is recommended to always reset the device before starting the 12V enable sequence.

During power-up, the Power-on Reset (POR) must be released before the 12V pulse can be applied. The duration of the pulse is recommended in the range from 100  $\mu\text{s}$  to 1 ms, before tri-stating. When applying the rising edge of the 12V pulse, the UPDI will be reset. After tri-stating, the UPDI will remain in Reset until the  $\overline{\text{RESET}}$  pin is driven low by the debugger. This will release the UPDI Reset and initiate the same enable sequence as explained in [33.3.2.1 UPDI Enable with Fuse Override of  \$\overline{\text{RESET}}\$  Pin](#).

The following figure shows the 12V enable sequence.

**Figure 33-6. UPDI Enable Sequence by 12V Programming**



When enabled by 12V, only a POR will disable the UPDI configuration on the  $\overline{\text{RESET}}$  pin, and restore the default setting. If issuing a UPDI Disable command through the UPDIDIS bit in UPDI.CTRLB, the UPDI will be reset and the clock request will be canceled, but the  $\overline{\text{RESET}}$  pin will remain in UPDI configuration.

**Note:** If insufficient external protection is added to the UPDI Pin, an ESD pulse can be interpreted as a 12V override by the microcontroller and enables the UPDI.

### 33.3.2.3 UPDI Disable

Any programming or debug session should be terminated by writing the UPDIDIS bit in UPDI.CTRLB. Writing this bit will reset the UPDI including any decoded KEYS and disable the oscillator request for the module. If the disable operation is not performed the UPDI will stay enabled and request its oscillator, causing increased power consumption for the application.

During the enable sequence the UPDI can disable itself in case of a faulty enable sequence. There are two cases that will cause an automatic disable:

- A SYNCH character is not sent within 13.5 ms after the initial enable pulse described in [33.3.2.1 UPDI Enable with Fuse Override of RESET Pin](#).
- The first SYNCH character after an initiated enable is too short or too long to register as a valid SYNCH character. See [Table 33-2](#) for recommended baud rate operating ranges.

### 33.3.2.4 Output Enable Timer Protection for GPIO Configuration

When the  $\overline{\text{RESET}}$  Pin Configuration (RSTPINCFG) bits in FUSE.SYSCFG0 are 0x0, the  $\overline{\text{RESET}}$  pin is configured as GPIO. To avoid the potential conflict between the GPIO actively driving the output and a 12V UPDI enable sequence initiation, a timer protection is disabling the output enable for a minimum time of 8.8 ms after each System Reset.

It is always recommended to issue a System Reset before entering the 12V programming sequence.

### 33.3.2.5 UPDI Communication Error Handling

The UPDI contains a comprehensive error detection system that provides information to the debugger when recovering from an error scenario. The error detection consists of detecting physical transmission errors like start bit error, parity error, contention error, and frame error, to more high-level errors like access time-out error. See the PESIG bits in UPDI\_STATUSB for an overview of the available error signatures.

Whenever the UPDI detects an error, it will immediately transfer to an internal error state to avoid unwanted system communication. In the error state, the UPDI will ignore all incoming data requests, except if a BREAK character is transmitted. The following procedure should always be applied when recovering from an error condition.

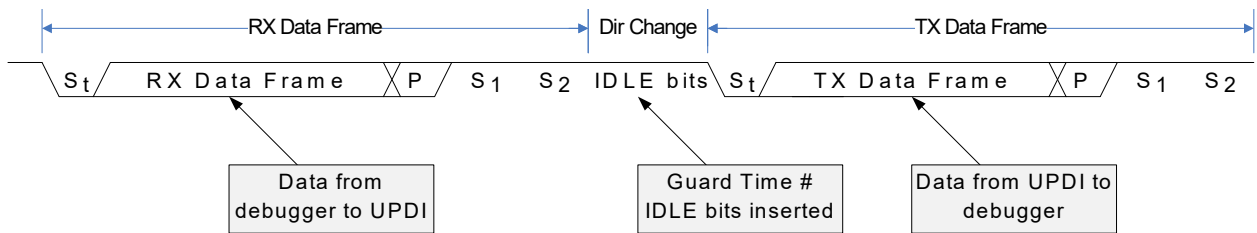
- Send a BREAK character. See [33.3.1.2 BREAK Character](#) for recommended BREAK character handling.
- Send a SYNCH character at the desired baud rate for the next data transfer. Upon receiving a BREAK the UPDI oscillator setting in UPDI.ASI\_CTRLA is reset to the 4 MHz default UPDI clock selection. This affects the baud rate range of the UPDI according to [Table 33-2](#).
- Do a Load Control Status (LDCS) to UPDI.STATUSB register to read the PESIG field. PESIG gives information about the occurred error, and the error signature will be cleared when read.
- The UPDI is now recovered from the error state and ready to receive the next SYNCH character and instruction.

### 33.3.2.6 Direction Change

In order to ensure correct timing for half duplex UART operation, the UPDI has a built-in Guard Time mechanism to relax the timing when changing direction from RX mode to TX mode. The Guard Time is a number of IDLE bits inserted before the next Start bit is transmitted. The number of IDLE bits can be configured through GTVAL in UPDI.CTRLA. The duration of each IDLE bit is given by the baud rate used by the current transmission.

It is not recommended to use GTVAL setting 0x7, with no additional IDLE bits.

**Figure 33-7. UPDI Direction Change by Inserting IDLE Bits**

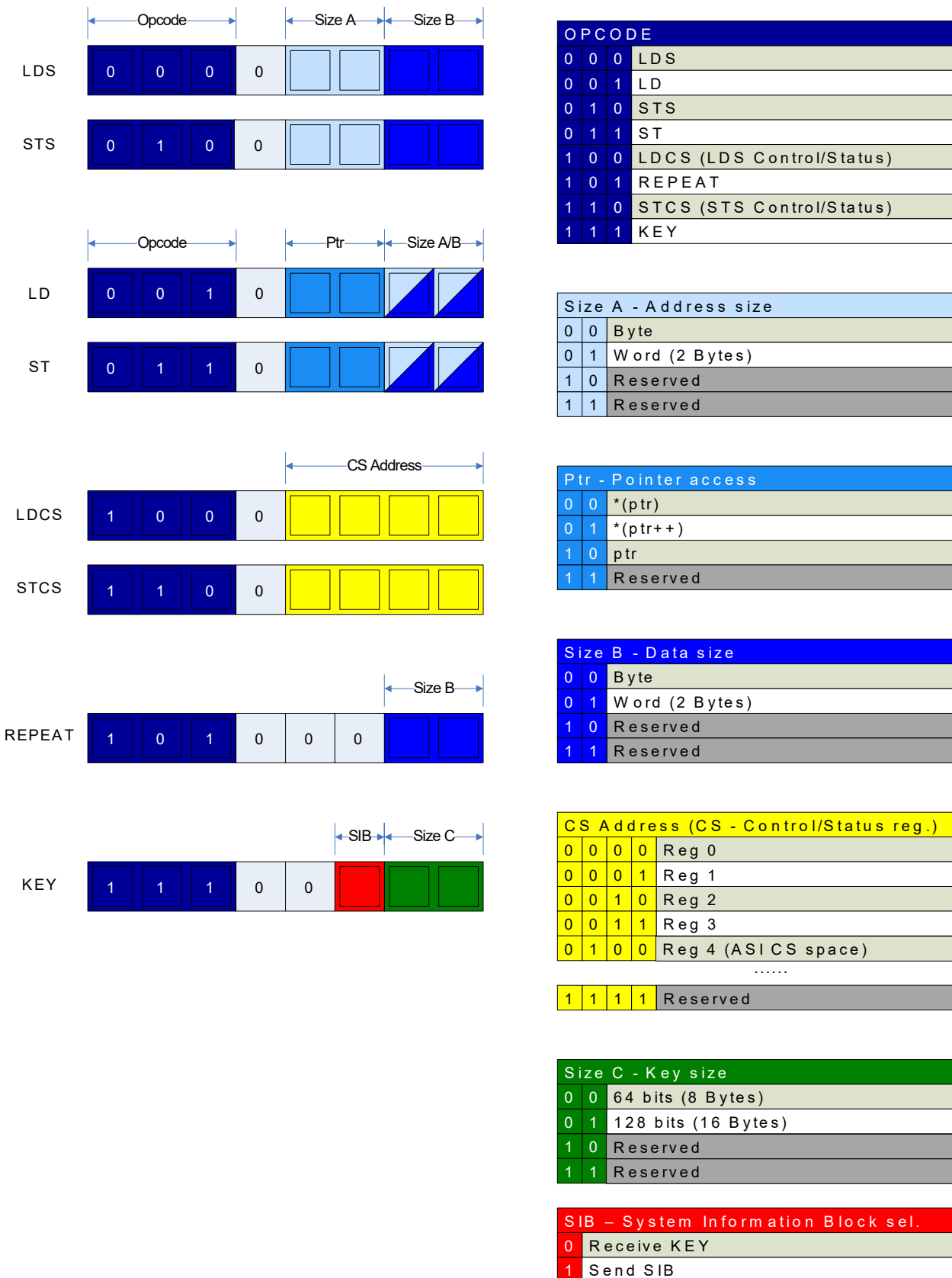


The UPDI Guard Time is the minimum IDLE time that the connected debugger will experience when waiting for data from the UPDI. Because of the asynchronous interface to the system, as presented in [33.2.2.1 Clocks](#), the ratio between the UPDI clock and the system clock will affect the synchronization time, and how long it takes before the UPDI can transmit data. In the cases where the synchronization delay is shorter than the current Guard Time setting, the Guard Time will be given by GTVAL directly.

### 33.3.3 UPDI Instruction Set

Communication through the UPDI is based on a small instruction set. The instructions are used to access the internal UPDI and ASI Control and Status (CS) space, as well as the memory mapped system space. All instructions are byte instructions and must be preceded by a SYNCH character to determine the baud rate for the communication. See [33.3.1.1 UPDI UART](#) for information about setting the baud rate for the transmission. The following figure gives an overview of the UPDI instruction set.

**Figure 33-8. UPDI Instruction Set Overview**

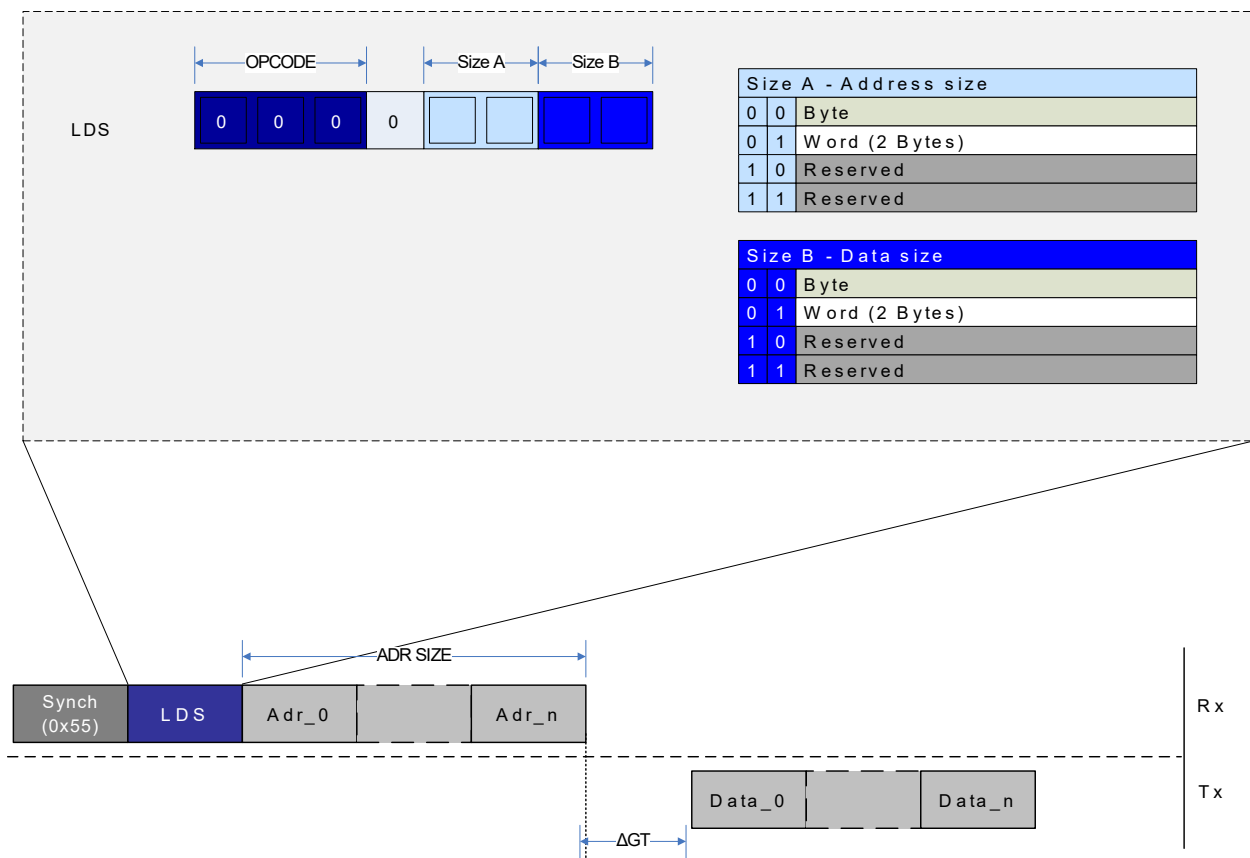


### 33.3.3.1 LDS - Load Data from Data Space Using Direct Addressing

The `LDS` instruction is used to load data from the bus matrix and into the serial shift register for serial readout. The `LDS` instruction is based on direct addressing, and the address must be given as an operand to the instruction for the data transfer to start. Maximum supported size for address and data is 16 bits. `LDS` instruction supports repeated memory access when combined with the `REPEAT` instruction.

As shown in [Figure 33-9](#), after issuing the `SYNCH` character followed by the `LDS` instruction, the number of desired address bytes, as indicated by the `Size A` field in the instruction, must be transmitted. The output data size is selected by the `Size B` field and is issued after the specified Guard Time. When combined with the `REPEAT` instruction, the address must be sent in for each iteration of the repeat, meaning after each time the output data sampling is done. There is no automatic address increment when using `REPEAT` with `LDS`, as it uses a direct addressing protocol.

**Figure 33-9. LDS Instruction Operation**

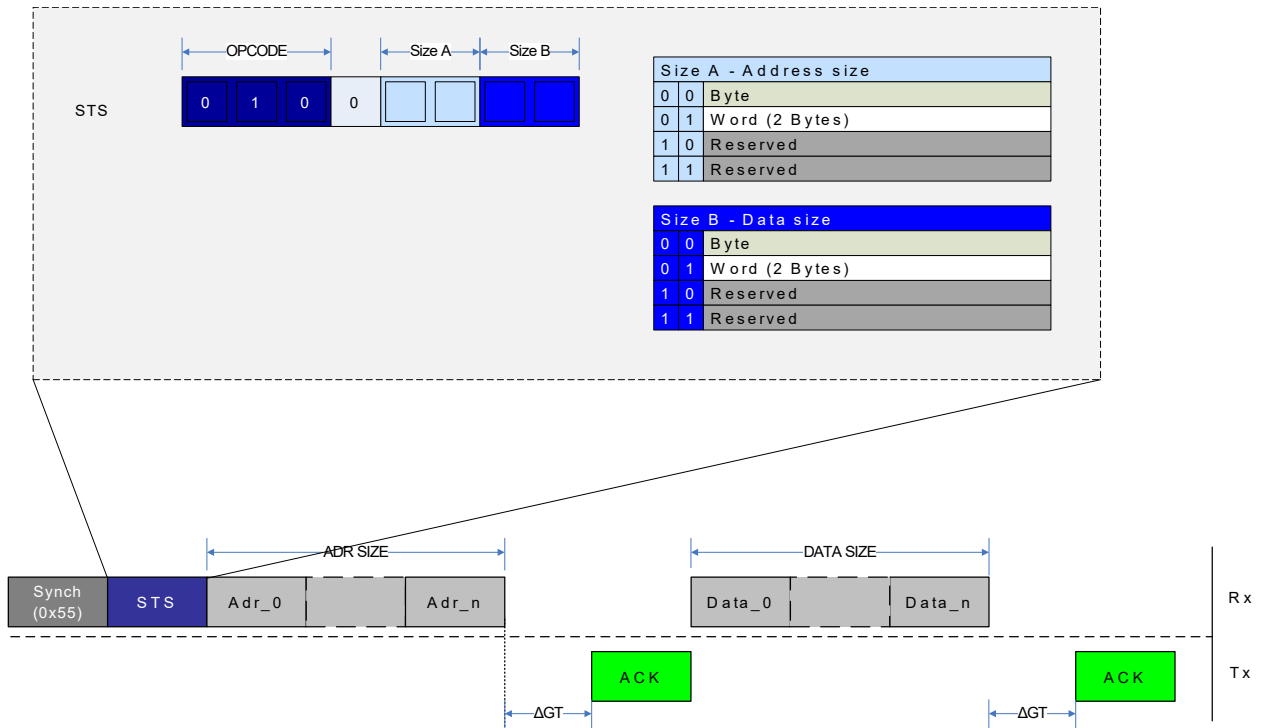


### 33.3.3.2 STS - Store Data to Data Space Using Direct Addressing

The `STS` instruction is used to store data that is shifted serially into the PHY layer to the bus matrix address space. The `STS` instruction is based on direct addressing, where the address is the first set of operands, and data is the second set. The size of the address and data operands are given by the size fields presented in the figure below. The maximum size for both address and data is 16 bits.

`STS` supports repeated memory access when combined with the `REPEAT` instruction.

**Figure 33-10. STS Instruction Operation**



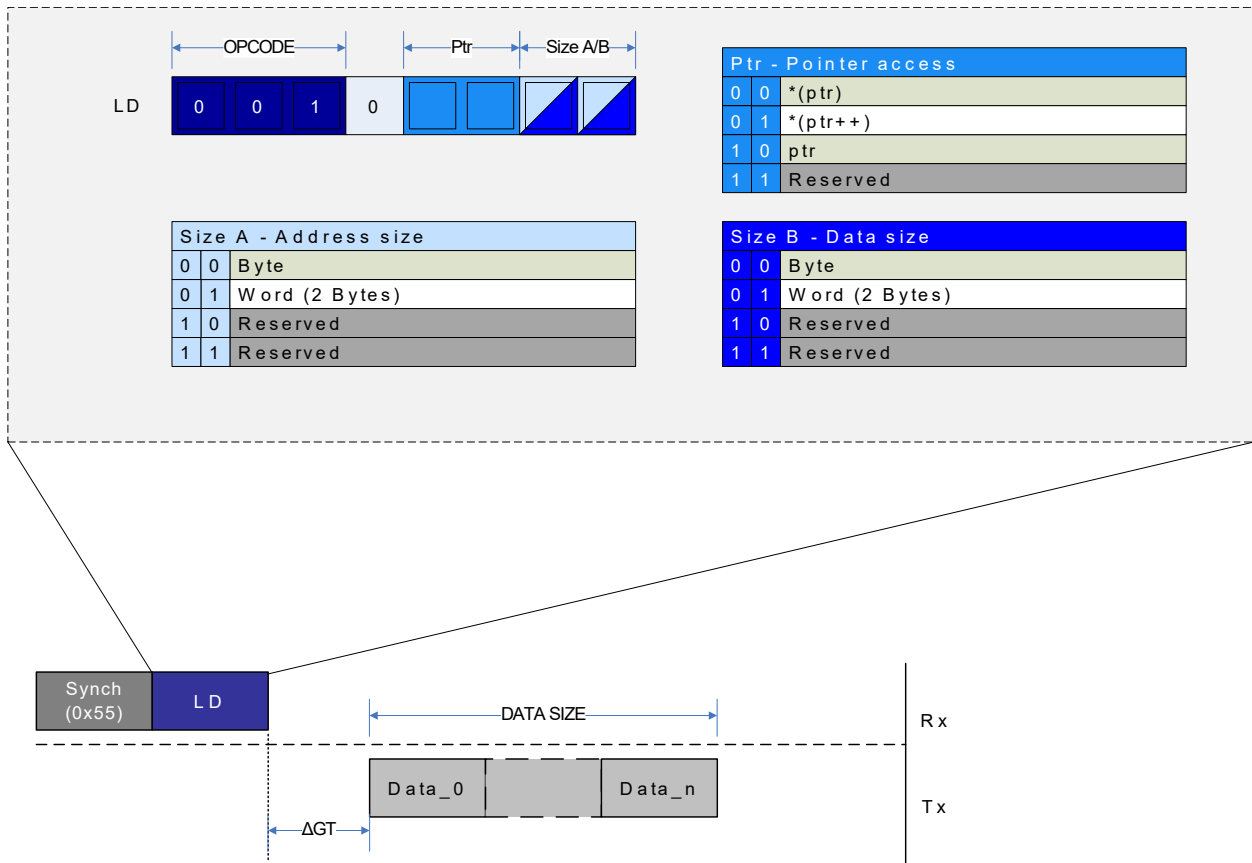
The transfer protocol for an STS instruction is depicted in the figure as well, following this sequence:

1. The address is sent.
2. An Acknowledge (ACK) is sent back from the UPDI if the transfer was successful.
3. The number of bytes as specified in the STS instruction is sent.
4. A new ACK is received after the data has been successfully transferred.

### 33.3.3.3 LD - Load Data from Data Space Using Indirect Addressing

The LD instruction is used to load data from the bus matrix and into the serial shift register for serial readout. The LD instruction is based on indirect addressing, which means that the Address Pointer in the UPDI needs to be written prior to bus matrix access. Automatic pointer post-increment operation is supported and is useful when the LD instruction is used with REPEAT. It is also possible to do an LD of the UPDI Pointer register. The maximum supported size for address and data load is 16 bits.

**Figure 33-11. LD Instruction Operation**



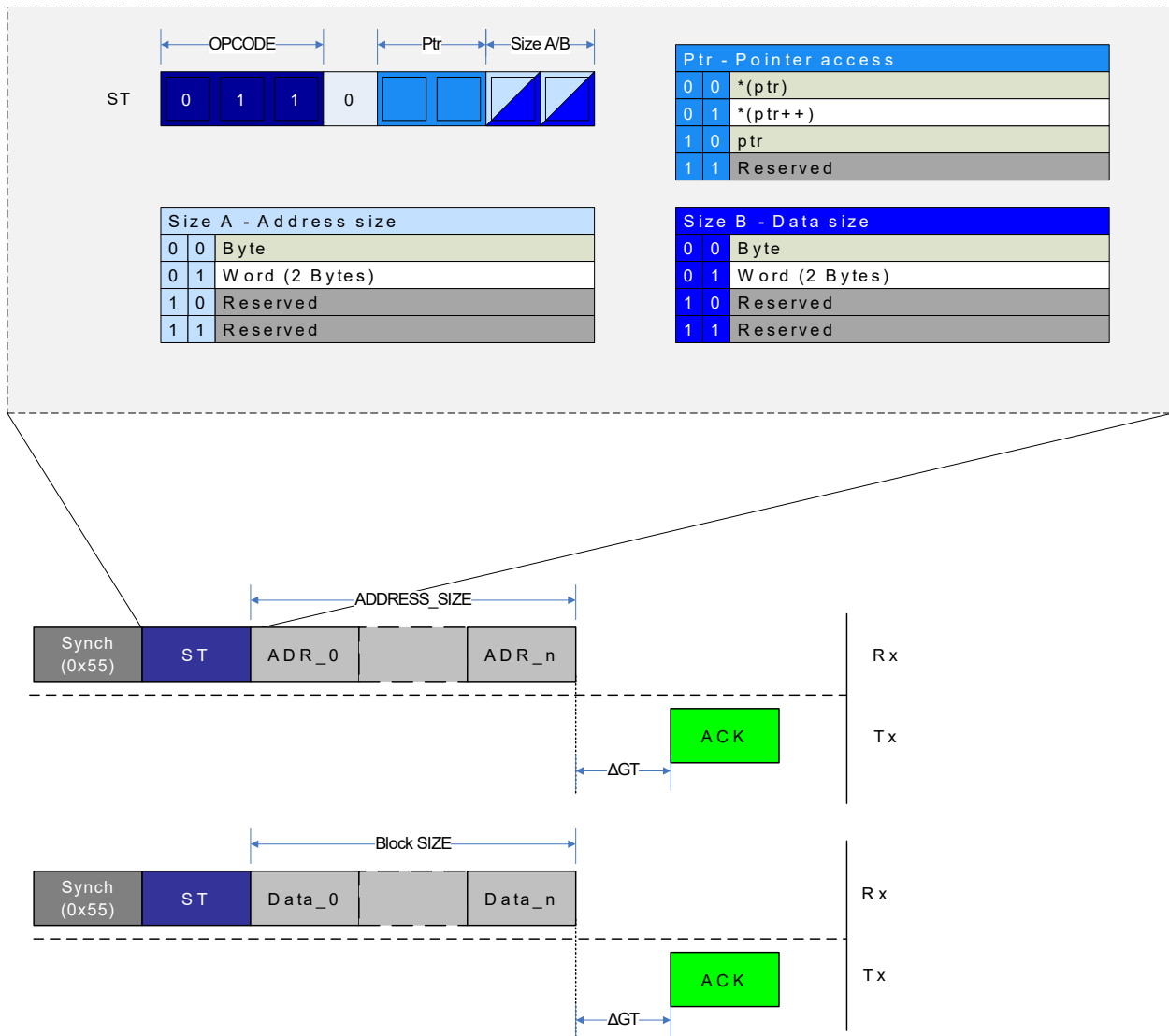
The figure above shows an example of a typical LD sequence, where data is received after the Guard Time period. Loading data from the UPDI Pointer register follows the same transmission protocol.

### 33.3.3.4 ST - Store Data from Data Space Using Indirect Addressing

The ST instruction is used to store data that is shifted serially into the PHY layer to the bus matrix address space. The ST instruction is based on indirect addressing, which means that the Address Pointer in the UPDI needs to be written prior to bus matrix access. Automatic pointer post-increment operation is supported, and is useful when the ST instruction is used with REPEAT. ST is also used to store the UPDI Address Pointer into the Pointer register. The maximum supported size for storing address and data is 16 bits.



**Figure 33-12. ST Instruction Operation**



The figure above gives an example of `ST` to the UPDI Pointer register and store of regular data. In both cases, an Acknowledge (ACK) is returned by the UPDI if the store was successful and a SYNCH character is sent before each instruction. To write the UPDI Pointer register, the following procedure should be followed:

- Set the PTR field in the `ST` instruction to the signature 0x2
- Set the address size field Size A to the desired address size
- After issuing the `ST` instruction, send Size A bytes of address data
- Wait for the ACK character, which signifies a successful write to the Address register

After the Address register is written, sending data is done in a similar fashion:

- Set the PTR field in the `ST` instruction to the signature 0x0 to write to the address specified by the UPDI Pointer register. If the PTR field is set to 0x1, the UPDI pointer is automatically updated to the next address according to the data size Size B field of the instruction after the write is executed
- Set the Size B field in the instruction to the desired data size
- After sending the `ST` instruction, send Size B bytes of address data

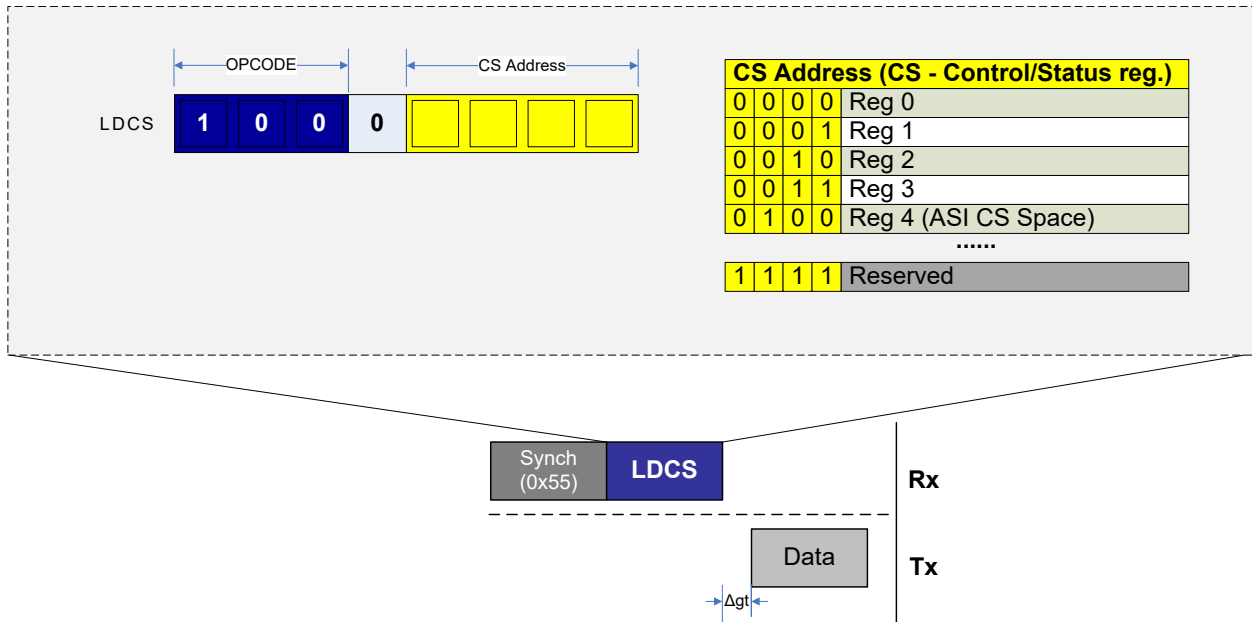
- Wait for the ACK character which signifies a successful write to the bus matrix

When used with the `REPEAT`, it is recommended to set up the address register with the start address for the block to be written and use the Pointer Post Increment register to automatically increase the address for each repeat cycle. When using `REPEAT`, the data frame of Size B data bytes can be sent after each received ACK.

### 33.3.3.5 LCDS - Load Data from Control and Status Register Space

The `LCDS` instruction is used to load data from the UPDI and ASI CS-space. `LCDS` is based on direct addressing, where the address is part of the instruction opcode. The total address space for `LCDS` is 16 bytes and can only access the internal UPDI register space. This instruction only supports byte access and the data size is not configurable.

**Figure 33-13. LCDS Instruction Operation**



The figure above shows a typical example of `LCDS` data transmission. A data byte from the `LCDS` space is transmitted from the UPDI after the Guard Time is completed.

### 33.3.3.6 STCS (Store Data to Control and Status Register Space)

The `STCS` instruction is used to store data to the UPDI and ASI CS-space. `STCS` is based on direct addressing, where the address is part of the instruction opcode. The total address space for `STCS` is 16 bytes, and can only access the internal UPDI register space. This instruction only supports byte access, and data size is not configurable.

**Figure 33-14. STCS Instruction Operation**

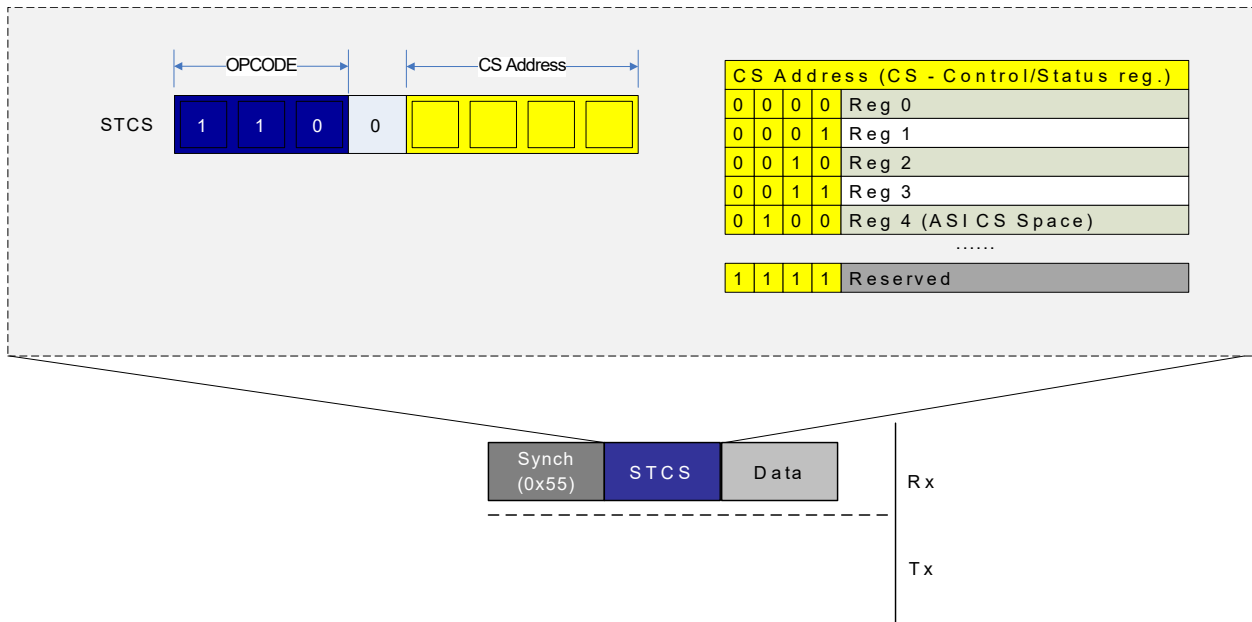


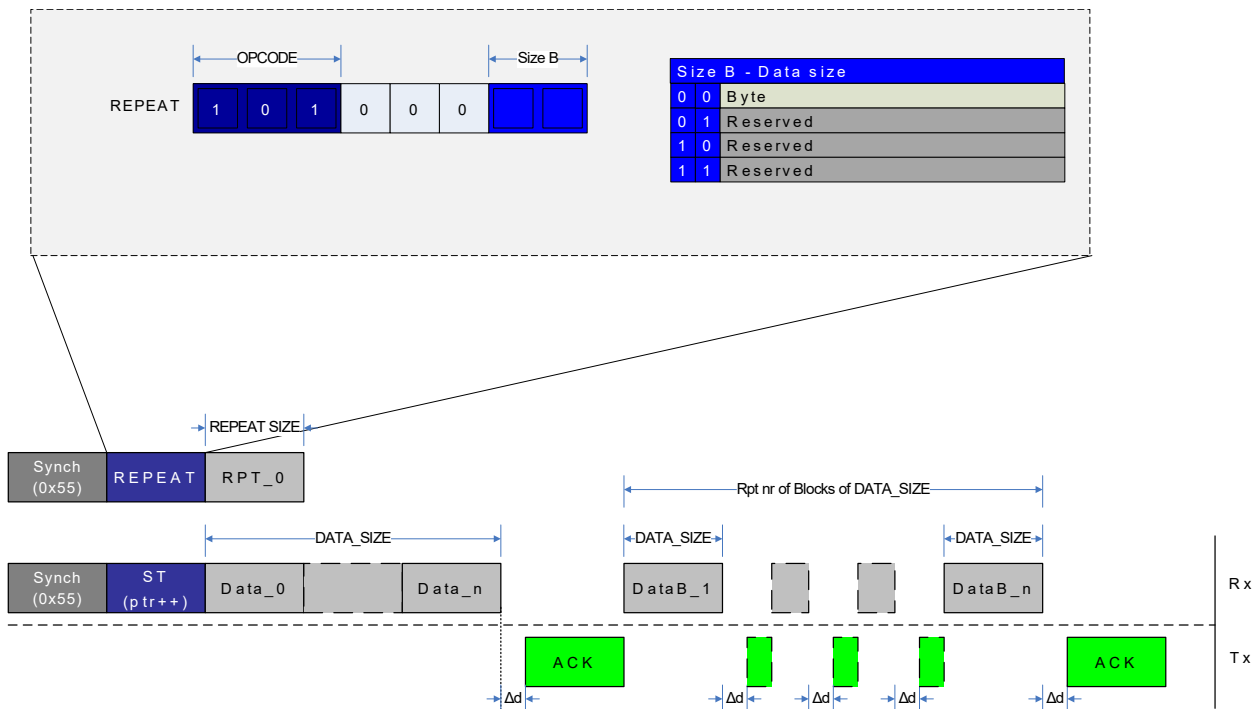
Figure 33-14 shows the data frame transmitted after the SYNCH and instruction frames. There is no response generated from the `STCS` instruction, as is the case for `ST` and `STS`.

### 33.3.3.7 REPEAT - Set Instruction Repeat Counter

The `REPEAT` instruction is used to store the repeat count value into the UPDI Repeat Counter register. When instructions are used with `REPEAT`, protocol overhead for SYNCH and Instruction Frame can be omitted on all instructions except the first instruction after the `REPEAT` is issued. `REPEAT` is most useful for memory instructions (`LD`, `ST`, `LDS`, `STS`), but all instructions can be repeated, except the `REPEAT` instruction itself.

The `DATA_SIZE` opcode field refers to the size of the repeat value. Only byte size (up to 255 repeats) is supported. The instruction that is loaded directly after the `REPEAT` instruction will be repeated `RPT_0` times. The instruction will be issued a total of `RPT_0 + 1` times. An ongoing repeat can only be aborted by sending a `BREAK` character.

**Figure 33-15. REPEAT Instruction Operation**



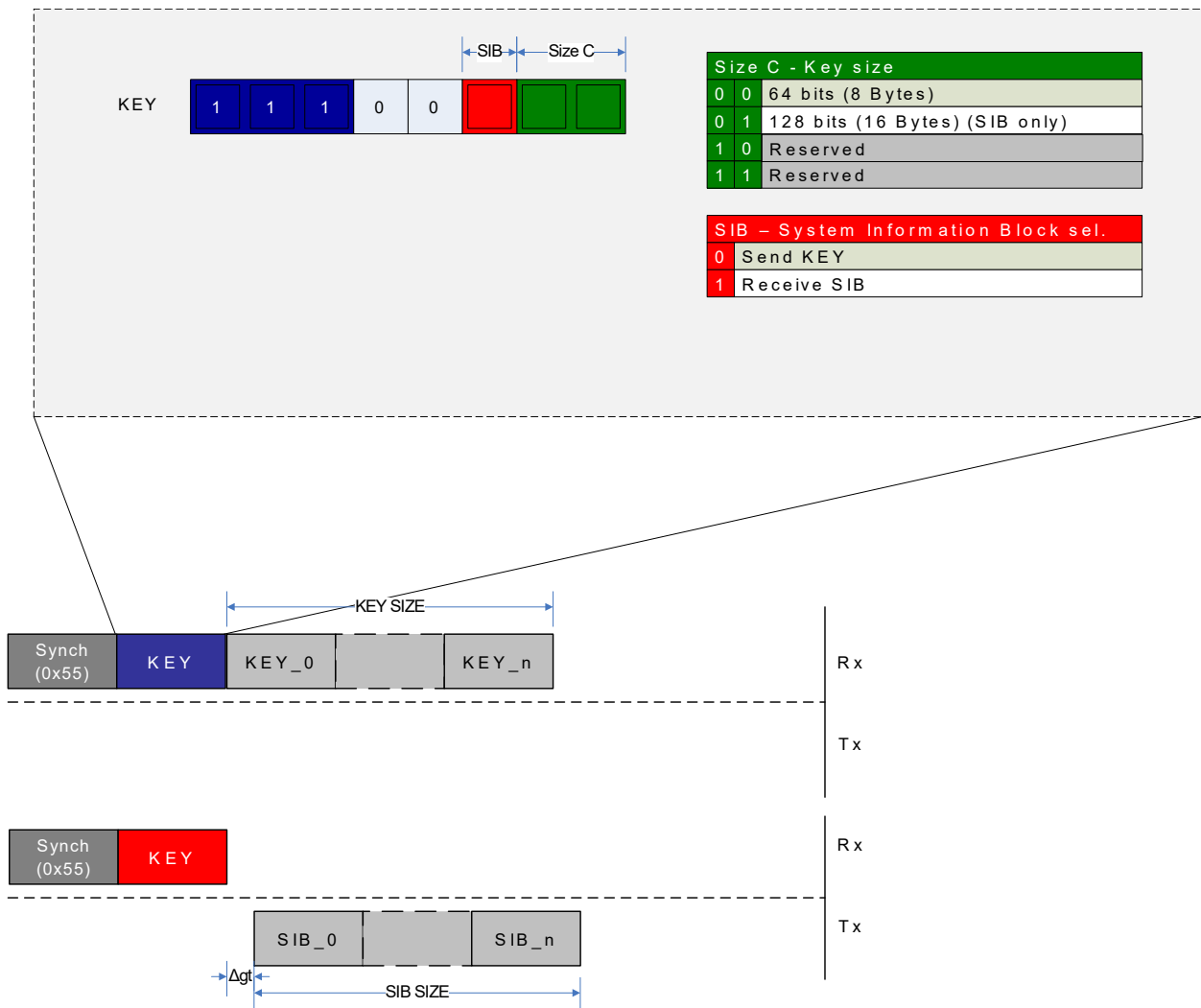
The figure above gives an example of repeat operation with an ST instruction using pointer post-increment operation. After the REPEAT instruction is sent with RPT\_0 = *n*, the first ST instruction is issued with SYNCH and Instruction frame, while the next *n* ST instructions are executed by only sending in data bytes according to the ST operand DATA\_SIZE, and maintaining the Acknowledge (ACK) handshake protocol.

If using indirect addressing instructions (LD/ST) it is recommended to always use the pointer post increment option when combined with REPEAT. Otherwise, the same address will be accessed in all repeated access operations. For direct addressing instructions (LDS/STS), the address must always be transmitted as specified in the instruction protocol, before data can be received (LDS) or sent (STS).

### 33.3.3.8 KEY - Set Activation KEY

The KEY instruction is used for communicating KEY bytes to the UPDI, opening up for executing protected features on the device. See Table 33-5 for an overview of functions that are activated by KEYs. For the KEY instruction, only 64-bit KEY size is supported. If the System Information Block (SIB) field of the KEY instruction is set, the KEY instruction returns the SIB instead of expecting incoming KEY bytes. Maximum supported size for SIB is 128 bits.

**Figure 33-16. KEY Instruction Operation**



The figure above shows the transmission of a KEY and the reception of a SIB. In both cases, the `SIZE_C` field in the opcode determines the number of frames being sent or received. There is no response after sending a `KEY` to the UPDI. When requesting the SIB, data will be transmitted from the UPDI according to the current Guard Time setting.

### 33.3.4 System Clock Measurement with UPDI

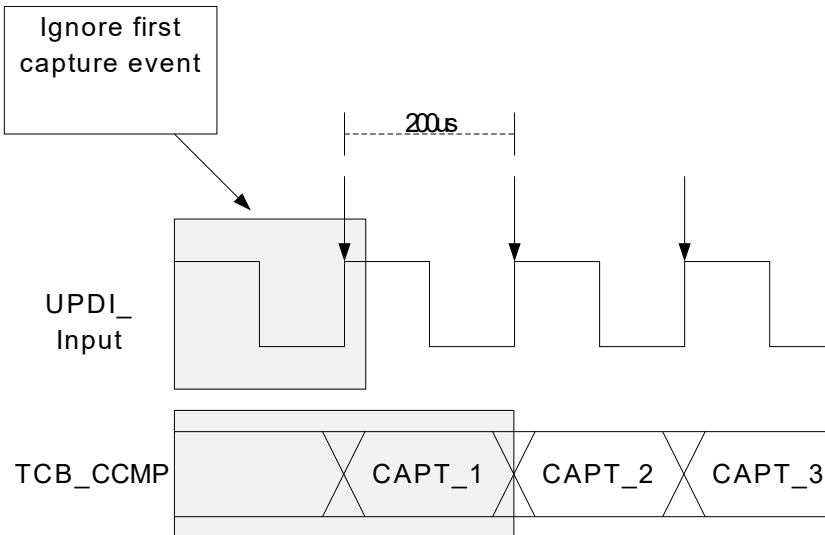
It is possible to use the UPDI to get an accurate measurement of the system clock frequency, by using the UPDI event connected to TCB with Input Capture capabilities. A recommended setup flow for this feature is given by the following steps:

- Set up `TCBn.CTRLB` with setting `CNTMODE=0x3`, Input Capture Frequency Measurement mode.
- Write `CAPTEI=1` in `TCBn.EVCTRL` to enable Event Interrupt. Keep `EDGE = 0` in `TCBn.EVCTRL`.
- Configure the Event System as described in [33.3.8 Events](#).
- For the `SYNCH` character used to generate the UPDI events, it is recommended to use a slow baud rate in the range of 10 kbps - 50 kbps to get a more accurate measurement on the value captured by the timer between each UPDI event. One particular thing is that if the capture is set up to trigger an interrupt, the first captured value should be ignored. The second captured value based

on the input event should be used for the measurement. See the figure below for an example using 10 kbps UPDI SYNCH character pulses, giving a capture window of 200  $\mu$ s for the timer.

- It is possible to read out the captured value directly after the SYNCH character by reading the TCBn.CCMP register or the value can be written to memory by the CPU once the capture is done.

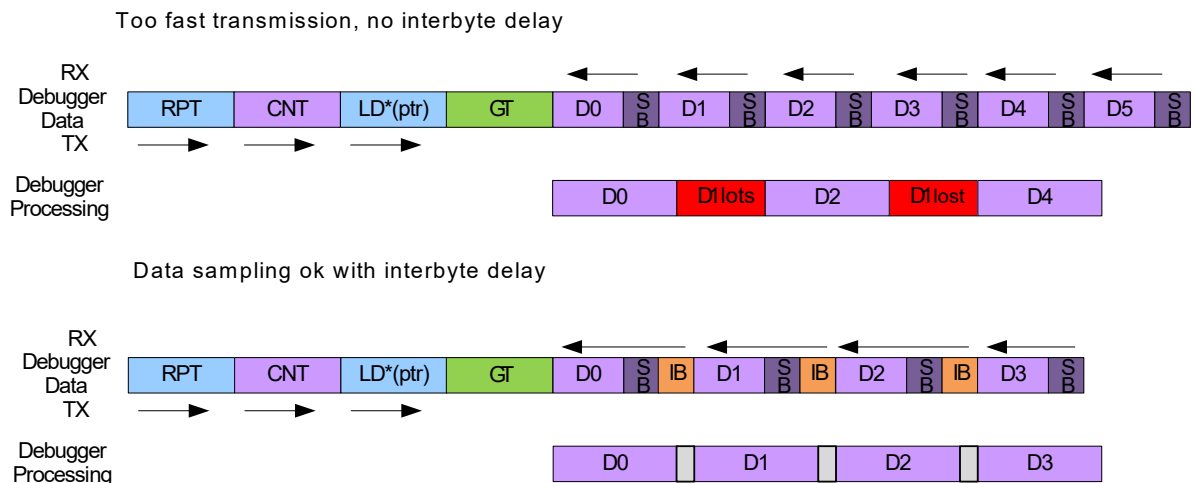
**Figure 33-17. UPDI System Clock Measurement Events**



### 33.3.5 Interbyte Delay

When loading data with the UPDI, or reading out the System Information Block, the output data will normally appear with two IDLE bits between each transmitted byte for a multibyte transfer. Depending on the application on the receiver side, data might be coming out too fast when there are no extra IDLE bits between each byte. By enabling the IBDLY feature in UPDI.CTRLB, two extra Stop bits will be inserted between each byte to relax the sampling time for the debugger. Interbyte delay works in the same way as a guard time, by inserting extra IDLE bits, but only a fixed number of IDLE bits and only for multibyte transfers. The first transmitted byte after a direction change will be subject to the regular Guard Time before it is transmitted, and the interbyte delay is not added to this time.

**Figure 33-18. Interbyte Delay Example with LD and RPT**



GT denotes the Guard Time insertion, SB is for Stop bit and IB is the inserted interbyte delay. The rest of the frames are data and instructions.

### 33.3.6 System Information Block

The System Information Block (SIB) can be read out at any time by setting the SIB bit in the `KEY` instruction from [33.3.3.8 KEY - Set Activation KEY](#). The SIB provides a compact form of providing information for the debugger, which is vital in identifying and setting up the proper communication channel with the part. The output of the SIB should be interpreted as ASCII symbols. The `KEY` size field should be set to 16 bytes when reading out the complete SIB, and an 8-byte size can be used to read out only the `Family_ID`. See [Figure 33-19](#) for SIB format description, and which data is available at different readout sizes.

**Figure 33-19. System Information Block Format**

16	8	[Byte][Bits]	Field Name
16	8	[6:0] [55:0]	Family_ID
		[7][7:0]	Reserved
	[10:8][23:0]	NVM_VERSION	
	[13:11][23:0]	OCD_VERSION	
	[14][7:0]	RESERVED	
	[15][7:0]	DBG_OSC_FREQ	

### 33.3.7 Enabling of KEY Protected Interfaces

Access to some internal interfaces and features are protected by the UPDI `KEY` mechanism. To activate a `KEY`, the correct `KEY` data must be transmitted by using the `KEY` instruction as described in [KEY instruction](#). The following table describes the available `KEY`s, and the condition required when doing the operation with the `KEY` active. There is no requirement when shifting in the `KEY`, but you would, for instance, normally run a Chip Erase before enabling the `NVMPROG` `KEY` to unlock the device for debugging. But if the `NVMPROG` `KEY` is shifted in first, it will not be reset by shifting in the Chip Erase `KEY` afterward.

**Table 33-5. KEY Activation Overview**

KEY Name	Description	Requirements for Operation	Reset
Chip Erase	Start NVM Chip erase. Clear Lockbits	None	UPDI Disable/UPDI Reset
NVMPROG	Activate NVM Programming	Lockbits Cleared. ASI_SYS_STATUS.NVM PROG set.	Programming Done/ UPDI Reset
USERROW-Write	Program User Row on Locked part	Lockbits Set. ASI_SYS_STATUS.URO WPROG set.	Write to KEY status bit/ UPDI Reset

The next table gives an overview of the available `KEY` signatures that must be shifted in to activate the interfaces.

**Table 33-6. KEY Activation Signatures**

KEY Name	KEY Signature (LSB Written First)	Size
Chip Erase	0x4E564D4572617365	64 bits
NVMPROG	0x4E564D50726F6720	64 bits
USERROW-Write	0x4E564D5573267465	64 bits

### 33.3.7.1 Chip Erase

The following steps should be followed to issue a Chip Erase.

1. Enter the CHIPERASE KEY by using the `KEY` instruction. See [Table 33-6](#) for the CHIPERASE signature.
2. **Optional:** Read the Chip Erase bit in the AS Key Status register (CHIPERASE in `UPDI.ASI_KEY_STATUS`) to see that the KEY is successfully activated.
3. Write the Reset signature into the `UPDI.ASI_RESET_REQ` register. This will issue a System Reset.
4. Write 0x00 to the ASI Reset Request register (`UPDI.ASI_RESET_REQ`) to clear the System Reset.
5. Read the Lock Status bit in the ASI System Status register (LOCKSTATUS in `UPDI.ASI_SYS_STATUS`).
6. Chip Erase is done when `LOCKSTATUS == 0` in `UPDI.ASI_SYS_STATUS`. If `LOCKSTATUS == 1`, go to point 5 again.

After a successful Chip Erase, the Lockbits will be cleared, and the UPDI will have full access to the system. Until Lockbits are cleared, the UPDI cannot access the system bus, and only CS-space operations can be performed.



During Chip Erase, the BOD is forced ON (`ACTIVE=0x1` in `BOD.CTRLA`) and uses the BOD Level from the BOD Configuration fuse (`LVL` in `BOD.CTRLB` = `LVL` in `FUSE.BODCFG`). If the supply voltage  $V_{DD}$  is below that threshold level, the device is unserviceable until  $V_{DD}$  is increased adequately.

### 33.3.7.2 NVM Programming

If the device is unlocked, it is possible to write directly to the NVM Controller using the UPDI. This will lead to unpredictable code execution if the CPU is active during the NVM programming. To avoid this, the following NVM Programming sequence should be executed.

1. Follow the Chip Erase procedure as described in [Chip Erase](#). If the part is already unlocked, this point can be skipped.
2. Enter the NVMPROG KEY by using the `KEY` instruction. See [Table 33-6](#) for the NVMPROG signature.
3. **Optional:** Read the NVMPROG field in the `KEY_STATUS` register to see that the KEY has been activated.
4. Write the Reset signature into the `ASI_RESET_REQ` register. This will issue a System Reset.
5. Write 0x00 to the Reset signature in the `ASI_RESET_REQ` register to clear the System Reset.
6. Read NVMPROG in `ASI_SYS_STATUS`.
7. NVM Programming can start when `NVMPROG == 1` in the `ASI_SYS_STATUS` register. If `NVMPROG == 0`, go to point 6 again.



8. Write data to NVM through the UPDI.
9. Write the Reset signature into the ASI\_RESET\_REQ register. This will issue a System Reset.
10. Write 0x00 to the Reset signature in the ASI\_RESET\_REQ register to clear the System Reset.
11. Programming is complete.

### 33.3.7.3 User Row Programming

The User Row Programming feature allows the user to program new values to the User Row (USERROW) on a locked device. To program with this functionality enabled, the following sequence should be followed.

1. Enter the USERROW-Write KEY located in [Table 33-6](#) by using the `KEY` instruction. See [Table 33-6](#) for the UROWWRITE signature.
2. **Optional:** Read the UROWWRITE bit field in `UPDI.ASI_KEY_STATUS` to see that the KEY has been activated.
3. Write the Reset signature into the `UPDI.ASI_RESET_REQ` register. This will issue a System Reset.
4. Write 0x00 to the Reset signature in the `UPDI.ASI_RESET_REQ` register to clear the System Reset.
5. Read the UROWPROG bit in `UPDI.ASI_SYS_STATUS`.
6. User Row Programming can start when `UROWPROG == 1`. If `UROWPROG == 0`, go to point 5 again.
7. The writable area has a size of one EEPROM page, 32 bytes, and it is only possible to write User Row data to the first 32 byte addresses of the RAM. Addressing outside this memory range will result in a non-executed write. The data will map 1:1 with the User Row space when the data is copied into the User Row upon completion of the Programming sequence.
8. When all User Row data has been written to the RAM, write the UROWWRITEFINAL bit in `UPDI.ASI_SYS_CTRLA`.
9. Read the UROWPROG bit in `UPDI.ASI_SYS_STATUS`.
10. The User Row Programming is completed when `UROWPROG == 0`. If `UROWPROG == 1`, go to point 9 again.
11. Write the UROWWRITE bit in `UPDI.ASI_KEY_STATUS`.
12. Write the Reset signature into the `UPDI.ASI_RESET_REQ` register. This will issue a System Reset.
13. Write 0x00 to the Reset signature in the `UPDI.ASI_RESET_REQ` register to clear the System Reset.
14. User Row Programming is complete.

It is not possible to read back data from the SRAM in this mode. Only writing to the first 32 bytes of the SRAM is allowed.

### 33.3.8 Events

The UPDI is connected to the Event System (EVSYS) as described in the register *Asynchronous Channel n Generator Selection*.

The UPDI can generate the following output events:

- SYNCH Character Positive Edge Event

This event is set on the UPDI clock for each detected positive edge in the SYNCH character, and it is not possible to disable this event from the UPDI. The recommended application for this event is system clock frequency measurement through the UPDI. Section [33.3.4 System Clock Measurement with UPDI](#) provides the details on how to set up the system for this operation.

**Related Links**[14. EVSYS - Event System](#)**33.3.9 Sleep Mode Operation**

The UPDI physical layer runs independently of all sleep modes and the UPDI is always accessible for a connected debugger independent of the device sleep mode. If the system enters a sleep mode that turns the CPU clock OFF, the UPDI will not be able to access the system bus and read memories and peripherals. The UPDI physical layer clock is unaffected by the sleep mode settings, as long as the UPDI is enabled. By reading the INSLEEP bit in UPDI.ASI\_SYS\_STATUS it is possible to monitor if the system domain is in sleep mode. The INSLEEP bit is set if the system is in IDLE Sleep mode or deeper.

It is possible to prevent the system clock from stopping when going into sleep mode, by writing the CLKREQ bit in UPDI.ASI\_SYS\_CTRL to '1'. If this bit is set, the system sleep mode state is emulated, and it is possible for the UPDI to access the system bus and read the peripheral registers even in the deepest sleep modes.

CLKREQ in UPDI.ASI\_SYS\_CTRL is by default '1', which means that the default operation is keeping the system clock on during sleep modes.

### 33.4 Register Summary - UPDI

Offset	Name	Bit Pos.								
0x00	<a href="#">STATUSA</a>	7:0	UPDIREV[3:0]							
0x01	<a href="#">STATUSB</a>	7:0						PESIG[2:0]		
0x02	<a href="#">CTRLA</a>	7:0	IBDLY		PARD	DTD	RSD	GTVAL[2:0]		
0x03	<a href="#">CTRLB</a>	7:0				NACKDIS	CCDETDIS	UPDIDIS		
0x04	Reserved									
...										
0x06										
0x07	<a href="#">ASI_KEY_STATUS</a>	7:0			UROWWRITE	NVMPROG	CHIPERASE			
0x08	<a href="#">ASI_RESET_REQ</a>	7:0	RSTREQ[7:0]							
0x09	<a href="#">ASI_CTRLA</a>	7:0						UPDICKSEL[1:0]		
0x0A	<a href="#">ASI_SYS_CTRLA</a>	7:0						UROWWRITE _FINAL	CLKREQ	
0x0B	<a href="#">ASI_SYS_STATUS</a>	7:0			RSTSYS	INSLEEP	NVMPROG	UROWPROG	LOCKSTATUS	
0x0C	<a href="#">ASI_CRC_STATUS</a>	7:0						CRC_STATUS[2:0]		

### 33.5 Register Description

These registers are readable only through the UPDI with special instructions and are NOT readable through the CPU.

Registers at offset addresses 0x0-0x3 are the UPDI Physical configuration registers.

Registers at offset addresses 0x4-0xC are the ASI level registers.

### 33.5.1 Status A

**Name:** STATUSA  
**Offset:** 0x00  
**Reset:** 0x10  
**Property:** -

Bit	7	6	5	4	3	2	1	0
	UPDIREV[3:0]							
Access	R	R	R	R				
Reset	0	0	0	1				

#### Bits 7:4 – UPDIREV[3:0] UPDI Revision

These bits are read-only and contain the revision of the current UPDI implementation.

### 33.5.2 Status B

**Name:** STATUSB  
**Offset:** 0x01  
**Reset:** 0x00  
**Property:** -

Bit	7	6	5	4	3	2	1	0
						PESIG[2:0]		
Access						R	R	R
Reset						0	0	0

#### Bits 2:0 – PESIG[2:0] UPDI Error Signature

These bits describe the UPDI Error Signature and are set when an internal UPDI error condition occurs. The PESIG field is cleared on a read from the debugger.

**Table 33-7. Valid Error Signatures**

PESIG[2:0]	Error Type	Error Description
0x0	No error	No error detected (Default)
0x1	Parity error	Wrong sampling of the parity bit
0x2	Frame error	Wrong sampling of frame Stop bits
0x3	Access Layer Time-out Error	UPDI can get no data or response from the Access layer. Examples of error cases are system domain in Sleep or system domain Reset.
0x4	Clock Recovery error	Wrong sampling of frame Start bit
0x5	-	Reserved
0x6	Reserved	Reserved
0x7	Contention error	Signalize Driving Contention on the UPDI RXD/TXD line

### 33.5.3 Control A

**Name:** CTRLA  
**Offset:** 0x02  
**Reset:** 0x00  
**Property:** -

Bit	7	6	5	4	3	2	1	0
	IBDLY		PARD	DTD	RSD	GTVAL[2:0]		
Access	R/W		R/W	R/W	R/W	R/W	R/W	R/W
Reset	0		0	0	0	0	0	0

#### Bit 7 – IBDLY Inter-Byte Delay Enable

Writing a '1' to this bit enables a fixed inter-byte delay between each data byte transmitted from the UPDI when doing multi-byte LD(S). The fixed length is two IDLE characters. Before the first transmitted byte, the regular GT delay used for direction change will be used.

#### Bit 5 – PARD Parity Disable

Writing this bit to '1' will disable parity detection in the UPDI by ignoring the Parity bit. This feature is recommended only during testing.

#### Bit 4 – DTD Disable Time-out Detection

Setting this bit disables the time-out detection on the PHY layer, which requests a response from the ACC layer within a specified time (65536 UPDI clock cycles).

#### Bit 3 – RSD Response Signature Disable

Writing a '1' to this bit will disable any response signatures generated by the UPDI. This is to reduce the protocol overhead to a minimum when writing large blocks of data to the NVM space. Disabling the Response Signature should be used with caution, and only when the delay experienced by the UPDI when accessing the system bus is predictable, otherwise loss of data may occur.

#### Bits 2:0 – GTVAL[2:0] Guard Time Value

This bit field selects the Guard Time Value that will be used by the UPDI when the transmission mode switches from RX to TX.

Value	Description
0x0	UPDI Guard Time: 128 cycles (default)
0x1	UPDI Guard Time: 64 cycles
0x2	UPDI Guard Time: 32 cycles
0x3	UPDI Guard Time: 16 cycles
0x4	UPDI Guard Time: 8 cycles
0x5	UPDI Guard Time: 4 cycles
0x6	UPDI Guard Time: 2 cycles
0x7	GT off (no extra Idle bits inserted)

### 33.5.4 Control B

**Name:** CTRLB  
**Offset:** 0x03  
**Reset:** 0x00  
**Property:** -

Bit	7	6	5	4	3	2	1	0
				NACKDIS	CCDETDIS	UPDIDIS		
Access				R	R	R		
Reset				0	0	0		

**Bit 4 – NACKDIS** Disable NACK Response

Writing this bit to '1' disables the NACK signature sent by the UPDI if a System Reset is issued during an ongoing LD(S) and ST(S) operation.

**Bit 3 – CCDETDIS** Collision and Contention Detection Disable

If this bit is written to '1', contention detection is disabled.

**Bit 2 – UPDIDIS** UPDI Disable

Writing a '1' to this bit disables the UPDI PHY interface. The clock request from the UPDI is lowered, and the UPDI is reset. All UPDI PHY configurations and KEYs will be reset when the UPDI is disabled.

### 33.5.5 ASI Key Status

**Name:** ASI\_KEY\_STATUS  
**Offset:** 0x07  
**Reset:** 0x00  
**Property:** -

Bit	7	6	5	4	3	2	1	0
			UROWWRITE	NVMPROG	CHIPERASE			
Access			R/W	R	R			
Reset			0	0	0			

**Bit 5 – UROWWRITE** User Row Write Key Status

This bit is set to '1' if the UROWWRITE KEY is active. Otherwise, this bit reads as zero.

**Bit 4 – NVMPROG** NVM Programming

This bit is set to '1' if the NVMPROG KEY is active. This bit is automatically reset after the programming sequence is done. Otherwise, this bit reads as zero.

**Bit 3 – CHIPERASE** Chip Erase

This bit is set to '1' if the CHIPERASE KEY is active. This bit will automatically be reset when the Chip Erase sequence is completed. Otherwise, this bit reads as zero.



### 33.5.6 ASI Reset Request

**Name:** ASI\_RESET\_REQ  
**Offset:** 0x08  
**Reset:** 0x00  
**Property:** -

Bit	7	6	5	4	3	2	1	0
	RSTREQ[7:0]							
Access	R/W	R/W	R/W	R/W	R/W	R/W	R/W	R/W
Reset	0	0	0	0	0	0	0	0

#### Bits 7:0 – RSTREQ[7:0] Reset Request

A Reset is signaled to the system when writing the Reset signature 0x59h to this address.

Writing any other signature to this register will clear the Reset.

When reading this register, reading bit RSTREQ[0] will tell if the UPDI is holding an active Reset on the system. If this bit is '1', the UPDI has an active Reset request to the system. All other bits will read as '0'.

The UPDI will not be reset when issuing a system Reset from this register.

### 33.5.7 ASI Control A

**Name:** ASI\_CTRLA  
**Offset:** 0x09  
**Reset:** 0x02  
**Property:** -

Bit	7	6	5	4	3	2	1	0
							UPDICKSEL[1:0]	
Access							R/W	R/W
Reset							1	1

#### Bits 1:0 – UPDICKSEL[1:0] UPDI Clock Select

Writing these bits select the UPDI clock output frequency. Default setting after Reset and enable is 4 MHz. Any other clock output selection is only recommended when the BOD is at the highest level. For all other BOD settings, the default 4 MHz selection is recommended.

Value	Description
0x0	Reserved
0x1	16 MHz UPDI clock
0x2	8 MHz UPDI clock
0x3	4 MHz UPDI clock (Default Setting)

### 33.5.8 ASI System Control A

**Name:** ASI\_SYS\_CTRLA  
**Offset:** 0x0A  
**Reset:** 0x00  
**Property:** -

Bit	7	6	5	4	3	2	1	0
							UROWWRITE_ FINAL	CLKREQ
Access	R	R	R	R	R	R	R/W	R/W
Reset	0	0	0	0	0	0	0	0

**Bit 1 – UROWWRITE\_FINAL** User Row Programming Done

This bit should be written through the UPDI when the user row data has been written to the RAM. Writing this bit will start the process of programming the user row data to the Flash.

If this bit is written before the User Row code is written to RAM by the UPDI, the CPU will progress without the written data.

This bit is only writable if the User Row-write KEY is successfully decoded.

**Bit 0 – CLKREQ** Request System Clock

If this bit is written to '1', the ASI is requesting the system clock, independent of system Sleep modes. This makes it possible for the UPDI to access the ACC layer, also if the system is in Sleep mode.

Writing a '0' to this bit will lower the clock request.

This bit will be reset when the UPDI is disabled.

This bit is set by default when the UPDI is enabled in any mode (Fuse, 12V).

### 33.5.9 ASI System Status

**Name:** ASI\_SYS\_STATUS  
**Offset:** 0x0B  
**Reset:** 0x01  
**Property:** -

Bit	7	6	5	4	3	2	1	0
			RSTSYS	INSLEEP	NVMPROG	UROWPROG		LOCKSTATUS
Access			R	R	R	R		R
Reset			0	0	0	0		1

#### Bit 5 – RSTSYS System Reset Active

If this bit is set, there is an active Reset on the system domain. If this bit is cleared, the system is not in Reset.

This bit is cleared on read.

A Reset held from the ASI\_RESET\_REQ register will also affect this bit.

#### Bit 4 – INSLEEP System Domain in Sleep

If this bit is set, the system domain is in IDLE or deeper Sleep mode. If this bit is cleared, the system is not in Sleep.

#### Bit 3 – NVMPROG Start NVM Programming

If this bit is set, NVM Programming can start from the UPDI.

When the UPDI is done, it must reset the system through the UPDI Reset register.

#### Bit 2 – UROWPROG Start User Row Programming

If this bit is set, User Row Programming can start from the UPDI.

When the UPDI is done, it must write the UROWWRITE\_FINAL bit in ASI\_SYS\_CTRLA.

#### Bit 0 – LOCKSTATUS NVM Lock Status

If this bit is set, the device is locked. If a Chip Erase is done, and the Lockbits are cleared, this bit will read as '0'.

### 33.5.10 ASI CRC Status

**Name:** ASI\_CRC\_STATUS  
**Offset:** 0x0C  
**Reset:** 0x00  
**Property:** -

Bit	7	6	5	4	3	2	1	0
						CRC_STATUS[2:0]		
Access						R	R	R
Reset						0	0	0

#### Bits 2:0 – CRC\_STATUS[2:0] CRC Execution Status

These bits signalize the status of the CRC conversion. The bits are one-hot encoded.

Value	Description
0x0	Not enabled
0x1	CRC enabled, busy
0x2	CRC enabled, done with OK signature
0x4	CRC enabled, done with FAILED signature
Other	Reserved

### 34. Instruction Set Summary

**Table 34-1. Arithmetic and Logic Instructions**

Mnemonic	Operands	Description		Op		Flags	#Clocks
ADD	Rd, Rr	Add without Carry	Rd	←	$Rd + Rr$	Z,C,N,V,S,H	1
ADC	Rd, Rr	Add with Carry	Rd	←	$Rd + Rr + C$	Z,C,N,V,S,H	1
ADIW	Rd, K	Add Immediate to Word	Rd + 1:Rd	←	$Rd + 1:Rd + K$	Z,C,N,V,S	2
SUB	Rd, Rr	Subtract without Carry	Rd	←	$Rd - Rr$	Z,C,N,V,S,H	1
SUBI	Rd, K	Subtract Immediate	Rd	←	$Rd - K$	Z,C,N,V,S,H	1
SBC	Rd, Rr	Subtract with Carry	Rd	←	$Rd - Rr - C$	Z,C,N,V,S,H	1
SBCI	Rd, K	Subtract Immediate with Carry	Rd	←	$Rd - K - C$	Z,C,N,V,S,H	1
SBIW	Rd, K	Subtract Immediate from Word	Rd + 1:Rd	←	$Rd + 1:Rd - K$	Z,C,N,V,S	2
AND	Rd, Rr	Logical AND	Rd	←	$Rd \cdot Rr$	Z,N,V,S	1
ANDI	Rd, K	Logical AND with Immediate	Rd	←	$Rd \cdot K$	Z,N,V,S	1
OR	Rd, Rr	Logical OR	Rd	←	$Rd \vee Rr$	Z,N,V,S	1
ORI	Rd, K	Logical OR with Immediate	Rd	←	$Rd \vee K$	Z,N,V,S	1
EOR	Rd, Rr	Exclusive OR	Rd	←	$Rd \oplus Rr$	Z,N,V,S	1
COM	Rd	One's Complement	Rd	←	$\$FF - Rd$	Z,C,N,V,S	1
NEG	Rd	Two's Complement	Rd	←	$\$00 - Rd$	Z,C,N,V,S,H	1
SBR	Rd,K	Set Bit(s) in Register	Rd	←	$Rd \vee K$	Z,N,V,S	1
CBR	Rd,K	Clear Bit(s) in Register	Rd	←	$Rd \cdot (\$FFh - K)$	Z,N,V,S	1
INC	Rd	Increment	Rd	←	$Rd + 1$	Z,N,V,S	1
DEC	Rd	Decrement	Rd	←	$Rd - 1$	Z,N,V,S	1
TST	Rd	Test for Zero or Minus	Rd	←	$Rd \cdot Rd$	Z,N,V,S	1
CLR	Rd	Clear Register	Rd	←	$Rd \oplus Rd$	Z,N,V,S	1
SER	Rd	Set Register	Rd	←	$\$FF$	None	1
MUL	Rd,Rr	Multiply Unsigned	R1:R0	←	$Rd \times Rr$ (UU)	Z,C	2
MULS	Rd,Rr	Multiply Signed	R1:R0	←	$Rd \times Rr$ (SS)	Z,C	2
MULSU	Rd,Rr	Multiply Signed with Unsigned	R1:R0	←	$Rd \times Rr$ (SU)	Z,C	2
FMUL	Rd,Rr	Fractional Multiply Unsigned	R1:R0	←	$Rd \times Rr \ll 1$ (UU)	Z,C	2
FMULS	Rd,Rr	Fractional Multiply Signed	R1:R0	←	$Rd \times Rr \ll 1$ (SS)	Z,C	2
FMULSU	Rd,Rr	Fractional Multiply Signed with Unsigned	R1:R0	←	$Rd \times Rr \ll 1$ (SU)	Z,C	2

**Table 34-2. Branch Instructions**

Mnemonic	Operands	Description		Op		Flags	#Clocks
RJMP	k	Relative Jump	PC	←	$PC + k + 1$	None	2
IJMP		Indirect Jump to (Z)	PC(15:0) PC(21:16)	← ←	Z 0	None	2
JMP	k	Jump	PC	←	k	None	3
RCALL	k	Relative Call Subroutine	PC	←	$PC + k + 1$	None	2 / 3
ICALL		Indirect Call to (Z)	PC(15:0)	←	Z	None	2 / 3

# ATtiny1614

## Instruction Set Summary

Mnemonic	Operands	Description		Op		Flags	#Clocks
			PC(21:16)	←	0		
CALL	k	Call Subroutine	PC	←	k	None	3 / 4
RET		Subroutine Return	PC	←	STACK	None	4 / 5
RETI		Interrupt Return	PC	←	STACK	I	4 / 5
CPSE	Rd,Rr	Compare, skip if Equal	if (Rd = Rr) PC	←	PC + 2 or 3	None	1 / 2 / 3
CP	Rd,Rr	Compare	Rd - Rr			Z,C,N,V,S,H	1
CPC	Rd,Rr	Compare with Carry	Rd - Rr - C			Z,C,N,V,S,H	1
CPI	Rd,K	Compare with Immediate	Rd - K			Z,C,N,V,S,H	1
SBRC	Rr, b	Skip if Bit in Register Cleared	if (Rr(b) = 0) PC	←	PC + 2 or 3	None	1 / 2 / 3
SBRS	Rr, b	Skip if Bit in Register Set	if (Rr(b) = 1) PC	←	PC + 2 or 3	None	1 / 2 / 3
SBIC	A, b	Skip if Bit in I/O Register Cleared	if (I/O(A,b) = 0) PC	←	PC + 2 or 3	None	1 / 2 / 3
SBIS	A, b	Skip if Bit in I/O Register Set	If (I/O(A,b)=1) PC	←	PC + 2 or 3	None	1 / 2 / 3
BRBS	s, k	Branch if Status Flag Set	if (SREG(s) = 1) then PC	←	PC + k + 1	None	1 / 2
BRBC	s, k	Branch if Status Flag Cleared	if (SREG(s) = 0) then PC	←	PC + k + 1	None	1 / 2
BREQ	k	Branch if Equal	if (Z = 1) then PC	←	PC + k + 1	None	1 / 2
BRNE	k	Branch if Not Equal	if (Z = 0) then PC	←	PC + k + 1	None	1 / 2
BRCS	k	Branch if Carry Set	if (C = 1) then PC	←	PC + k + 1	None	1 / 2
BRCC	k	Branch if Carry Cleared	if (C = 0) then PC	←	PC + k + 1	None	1 / 2
BRSH	k	Branch if Same or Higher	if (C = 0) then PC	←	PC + k + 1	None	1 / 2
BRLO	k	Branch if Lower	if (C = 1) then PC	←	PC + k + 1	None	1 / 2
BRMI	k	Branch if Minus	if (N = 1) then PC	←	PC + k + 1	None	1 / 2
BRPL	k	Branch if Plus	if (N = 0) then PC	←	PC + k + 1	None	1 / 2
BRGE	k	Branch if Greater or Equal, Signed	if (N ⊕ V = 0) then PC	←	PC + k + 1	None	1 / 2
BRLT	k	Branch if Less Than, Signed	if (N ⊕ V = 1) then PC	←	PC + k + 1	None	1 / 2
BRHS	k	Branch if Half Carry Flag Set	if (H = 1) then PC	←	PC + k + 1	None	1 / 2
BRHC	k	Branch if Half Carry Flag Cleared	if (H = 0) then PC	←	PC + k + 1	None	1 / 2
BRTS	k	Branch if T Flag Set	if (T = 1) then PC	←	PC + k + 1	None	1 / 2
BRTC	k	Branch if T Flag Cleared	if (T = 0) then PC	←	PC + k + 1	None	1 / 2
BRVS	k	Branch if Overflow Flag is Set	if (V = 1) then PC	←	PC + k + 1	None	1 / 2

# ATtiny1614

## Instruction Set Summary

Mnemonic	Operands	Description		Op		Flags	#Clocks
BRVC	k	Branch if Overflow Flag is Cleared	if (V = 0) then PC	←	PC + k + 1	None	1 / 2
BRIE	k	Branch if Interrupt Enabled	if (I = 1) then PC	←	PC + k + 1	None	1 / 2
BRID	k	Branch if Interrupt Disabled	if (I = 0) then PC	←	PC + k + 1	None	1 / 2

**Table 34-3. Data Transfer Instructions**

Mnemonic	Operands	Description		Op		Flags	#Clocks
MOV	Rd, Rr	Copy Register	Rd	←	Rr	None	1
MOVW	Rd, Rr	Copy Register Pair	Rd+1:Rd	←	Rr+1:Rr	None	1
LDI	Rd, K	Load Immediate	Rd	←	K	None	1
LDS	Rd, k	Load Direct from data space	Rd	←	(k)	None	3 <sup>(1)</sup>
LD	Rd, X	Load Indirect	Rd	←	(X)	None	2 <sup>(1)</sup>
LD	Rd, X+	Load Indirect and Post-Increment	Rd X	← ←	(X) X + 1	None	2 <sup>(1)</sup>
LD	Rd, -X	Load Indirect and Pre-Decrement	X Rd	← ←	X - 1 (X)	None	2 <sup>(1)</sup>
LD	Rd, Y	Load Indirect	Rd	←	(Y)	None	2 <sup>(1)</sup>
LD	Rd, Y+	Load Indirect and Post-Increment	Rd Y	← ←	(Y) Y + 1	None	2 <sup>(1)</sup>
LD	Rd, -Y	Load Indirect and Pre-Decrement	Y Rd	← ←	Y - 1 (Y)	None	2 <sup>(1)</sup>
LDD	Rd, Y+q	Load Indirect with Displacement	Rd	←	(Y + q)	None	2 <sup>(1)</sup>
LD	Rd, Z	Load Indirect	Rd	←	(Z)	None	2 <sup>(1)</sup>
LD	Rd, Z+	Load Indirect and Post-Increment	Rd Z	← ←	(Z) Z+1	None	2 <sup>(1)</sup>
LD	Rd, -Z	Load Indirect and Pre-Decrement	Z Rd	← ←	Z - 1 (Z)	None	2 <sup>(1)</sup>
LDD	Rd, Z+q	Load Indirect with Displacement	Rd	←	(Z + q)	None	2 <sup>(1)</sup>
STS	k, Rr	Store Direct to Data Space	(k)	←	Rr	None	2 <sup>(1)</sup>
ST	X, Rr	Store Indirect	(X)	←	Rr	None	1 <sup>(1)</sup>
ST	X+, Rr	Store Indirect and Post-Increment	(X) X	← ←	Rr X + 1	None	1 <sup>(1)</sup>
ST	-X, Rr	Store Indirect and Pre-Decrement	X (X)	← ←	X - 1 Rr	None	1 <sup>(1)</sup>
ST	Y, Rr	Store Indirect	(Y)	←	Rr	None	1 <sup>(1)</sup>
ST	Y+, Rr	Store Indirect and Post-Increment	(Y) Y	← ←	Rr Y + 1	None	1 <sup>(1)</sup>
ST	-Y, Rr	Store Indirect and Pre-Decrement	Y (Y)	← ←	Y - 1 Rr	None	1 <sup>(1)</sup>
STD	Y+q, Rr	Store Indirect with Displacement	(Y + q)	←	Rr	None	1 <sup>(1)</sup>



# ATtiny1614

## Instruction Set Summary

Mnemonic	Operands	Description		Op		Flags	#Clocks
ST	Z, Rr	Store Indirect	(Z)	←	Rr	None	1(1)
ST	Z+, Rr	Store Indirect and Post-Increment	(Z) Z	← ←	Rr Z + 1	None	1(1)
ST	-Z, Rr	Store Indirect and Pre-Decrement	Z	←	Z - 1	None	1(1)
STD	Z+q,Rr	Store Indirect with Displacement	(Z + q)	←	Rr	None	1(1)
LPM		Load Program Memory	R0	←	(Z)	None	3
LPM	Rd, Z	Load Program Memory	Rd	←	(Z)	None	3
LPM	Rd, Z+	Load Program Memory and Post-Increment	Rd Z	← ←	(Z) Z + 1	None	3
IN	Rd, A	In From I/O Location	Rd	←	I/O(A)	None	1
OUT	A, Rr	Out To I/O Location	I/O(A)	←	Rr	None	1
PUSH	Rr	Push Register on Stack	STACK	←	Rr	None	1
POP	Rd	Pop Register from Stack	Rd	←	STACK	None	2

**Table 34-4. Bit and Bit-Test Instructions**

Mnemonic	Operands	Description		Op		Flags	#Clocks
LSL	Rd	Logical Shift Left	Rd(n+1) Rd(0) C	← ← ←	Rd(n) 0 Rd(7)	Z,C,N,V,H	1
LSR	Rd	Logical Shift Right	Rd(n) Rd(7) C	← ← ←	Rd(n+1) 0 Rd(0)	Z,C,N,V	1
ROL	Rd	Rotate Left Through Carry	Rd(0) Rd(n+1) C	← ← ←	C Rd(n) Rd(7)	Z,C,N,V,H	1
ROR	Rd	Rotate Right Through Carry	Rd(7) Rd(n) C	← ← ←	C Rd(n+1) Rd(0)	Z,C,N,V	1
ASR	Rd	Arithmetic Shift Right	Rd(n)	←	Rd(n+1), n=0..6	Z,C,N,V	1
SWAP	Rd	Swap Nibbles	Rd(3..0)	↔	Rd(7..4)	None	1
SBI	A, b	Set Bit in I/O Register	I/O(A, b)	←	1	None	1
CBI	A, b	Clear Bit in I/O Register	I/O(A, b)	←	0	None	1
BST	Rr, b	Bit Store from Register to T	T	←	Rr(b)	T	1
BLD	Rd, b	Bit load from T to Register	Rd(b)	←	T	None	1
BSET	s	Flag Set	SREG(s)	←	1	SREG(s)	1
BCLR	s	Flag Clear	SREG(s)	←	0	SREG(s)	1
SEC		Set Carry	C	←	1	C	1
CLC		Clear Carry	C	←	0	C	1
SEN		Set Negative Flag	N	←	1	N	1
CLN		Clear Negative Flag	N	←	0	N	1
SEZ		Set Zero Flag	Z	←	1	Z	1

# ATtiny1614

## Instruction Set Summary

Mnemonic	Operands	Description		Op		Flags	#Clocks
CLZ		Clear Zero Flag	Z	←	0	Z	1
SEI		Global Interrupt Enable	I	←	1	I	1
CLI		Global Interrupt Disable	I	←	0	I	1
SES		Set Signed Test Flag	S	←	1	S	1
CLS		Clear Signed Test Flag	S	←	0	S	1
SEV		Set Two's Complement Overflow	V	←	1	V	1
CLV		Clear Two's Complement Overflow	V	←	0	V	1
SET		Set T in SREG	T	←	1	T	1
CLT		Clear T in SREG	T	←	0	T	1
SEH		Set Half Carry Flag in SREG	H	←	1	H	1
CLH		Clear Half Carry Flag in SREG	H	←	0	H	1

**Table 34-5. MCU Control Instructions**

Mnemonic	Operands	Description	Operation	Flags	#Clocks
BREAK		Break	(See also debug interface description)	None	1
NOP		No Operation		None	1
SLEEP		Sleep	(See also power management and sleep description)	None	1
WDR		Watchdog Reset	(See also Watchdog Controller description)	None	1

**Note:**

1. Cycle time for data memory accesses assume internal RAM access and are not valid for accesses through the NVM controller. A minimum of one extra cycle must be added when accessing memory through the NVM controller (such as Flash and EEPROM), but depending on simultaneous accesses by other masters or the NVM controller state, there may be more than one extra cycle.

## 35. Conventions

### 35.1 Numerical Notation

**Table 35-1. Numerical Notation**

Symbol	Description
165	Decimal number
0b0101	Binary number (example 0b0101 = 5 decimal)
'0101'	Binary numbers are given without prefix if unambiguous
0x3B24	Hexadecimal number
X	Represents an unknown or do not care value
Z	Represents a high-impedance (floating) state for either a signal or a bus

### 35.2 Memory Size and Type

**Table 35-2. Memory Size and Bit Rate**

Symbol	Description
KB	kilobyte ( $2^{10} = 1024$ )
MB	megabyte ( $2^{20} = 1024 \times 1024$ )
GB	gigabyte ( $2^{30} = 1024 \times 1024 \times 1024$ )
b	bit (binary '0' or '1')
B	byte (8 bits)
1 kbit/s	1,000 bit/s rate (not 1,024 bit/s)
1 Mbit/s	1,000,000 bit/s rate
1 Gbit/s	1,000,000,000 bit/s rate
word	16-bit

### 35.3 Frequency and Time

**Table 35-3. Frequency and Time**

Symbol	Description
kHz	1 kHz = $10^3$ Hz = 1,000 Hz
KHz	1 KHz = 1,024 Hz, 32 KHz = 32,768 Hz
MHz	1 MHz = $10^6$ Hz = 1,000,000 Hz

Symbol	Description
GHz	1 GHz = 10 <sup>9</sup> Hz = 1,000,000,000 Hz
s	second
ms	millisecond
μs	microsecond
ns	nanosecond

## 35.4 Registers and Bits

**Table 35-4. Register and Bit Mnemonics**

Symbol	Description
R/W	Read/Write accessible register bit. The user can read from and write to this bit.
R	Read-only accessible register bit. The user can only read this bit. Writes will be ignored.
W	Write-only accessible register bit. The user can only write this bit. Reading this bit will return an undefined value.
BIT	Bit names are shown in uppercase. (Example ENABLE)
FIELD[n:m]	A set of bits from bit n down to m. (Example: PINA[3:0] = {PINA3, PINA2, PINA1, PINA0})
Reserved	Reserved bits are unused and reserved for future use. For compatibility with future devices, always write reserved bits to zero when the register is written. Reserved bits will always return zero when read.  Reserved bit field values must not be written to a bit field. A reserved value will not be read from a read-only bit field.  Do not write any value to reserved bits of a fuse.
PERIPHERAL <i>i</i>	If several instances of a peripheral exist, the peripheral name is followed by a number to indicate the number of the instance in the range 0-n. PERIPHERAL0 denotes one specific instance.
Reset	Value of a register after a power Reset. This is also the value of registers in a peripheral after performing a software Reset of the peripheral, except for the Debug Control registers.
SET/CLR	Registers with SET/CLR suffix allows the user to clear and set bits in a register without doing a read-modify-write operation. These registers always come in pairs. Writing a '1' to a bit in the CLR register will clear the corresponding bit in both registers, while writing a '1' to a bit in the SET register will set the corresponding bit in both registers. Both registers will return the same value when read. If both registers are written simultaneously, the write to the CLR register will take precedence.

## 36. Acronyms and Abbreviations

The table below contains acronyms and abbreviations used in this document.

**Table 36-1. Acronyms and Abbreviations**

Abbreviation	Description
AC	Analog Comparator
ACK	Acknowledge
ADC	Analog-to-Digital Converter
ADDR	Address
AES	Advanced Encryption Standard
ALU	Arithmetic Logic Unit
AREF	Analog reference voltage, also VREFA
BLB	Boot Lock Bit
BOD	Brown-out Detector
CAL	Calibration
CCMP	Compare/Capture
CCL	Configurable Custom Logic
CCP	Configuration Change Protection
CLK	Clock
CLKCTRL	Clock Controller
CRC	Cyclic Redundancy Check
CTRL	Control
DAC	Digital-to-Analog Converter
DFLL	Digital Frequency Locked Loop
DMAC	DMA (Direct Memory Access) Controller
DNL	Differential Nonlinearity (ADC characteristics)
EEPROM	Electrically Erasable Programmable Read-Only Memory
EVSYS	Event System
GND	Ground
GPIO	General Purpose Input/Output
I <sup>2</sup> C	Inter-Integrated Circuit
IF	Interrupt flag
INL	Integral Nonlinearity (ADC characteristics)

# ATtiny1614

## Acronyms and Abbreviations

Abbreviation	Description
INT	Interrupt
IrDA	Infrared Data Association
IVEC	Interrupt Vector
LSB	Least Significant Byte
LSb	Least Significant bit
LUT	Look Up Table
MBIST	Memory Built-in Self-test
MSB	Most Significant Byte
MSb	Most Significant bit
NACK	Not Acknowledge
NMI	Non-maskable interrupt
NVM	Nonvolatile Memory
NVMCTRL	Nonvolatile Memory Controller
OPAMP	Operation Amplifier
OSC	Oscillator
PC	Program Counter
PER	Period
POR	Power-on Reset
PORT	I/O Pin Configuration
PTC	Peripheral Touch Controller
PWM	Pulse-width Modulation
RAM	Random Access Memory
REF	Reference
REQ	Request
RISC	Reduced Instruction Set Computer
RSTCTRL	Reset Controller
RTC	Real-time Counter
RX	Receiver/Receive
SERCOM	Serial Communication Interface
SLPCTRL	Sleep Controller
SMBus	System Management Bus
SP	Stack Pointer

# ATtiny1614

## Acronyms and Abbreviations

Abbreviation	Description
SPI	Serial Peripheral Interface
SRAM	Static Random Access Memory
SYSCFG	System Configuration
TC	Timer/Counter (Optionally superseded by a letter indicating type of TC)
TRNG	True Random Number Generator
TWI	Two-wire Interface
TX	Transmitter/Transmit
ULP	Ultra Low Power
UPDI	Unified Program and Debug Interface
USART	Universal Synchronous and Asynchronous Serial Receiver and Transmitter
USB	Universal Serial Bus
$V_{DD}$	Voltage to be applied to $V_{DD}$
VREF	Voltage Reference
$V_{CM}$	Voltage Common mode
WDT	Watchdog Timer
XOSC	Crystal Oscillator

## 37. Electrical Characteristics

### 37.1 Disclaimer

All typical values are measured at  $T = 25^{\circ}\text{C}$  and  $V_{\text{DD}} = 3\text{V}$  unless otherwise specified. All minimum and maximum values are valid across operating temperature and voltage unless otherwise specified.

### 37.2 Absolute Maximum Ratings

Stresses beyond those listed in this section may cause permanent damage to the device. This is a stress rating only and functional operation of the device at these or other conditions beyond those indicated in the operational sections of this specification is not implied. Exposure to absolute maximum rating conditions for extended periods may affect device reliability.

**Table 37-1. Absolute Maximum Ratings**

Symbol	Description	Conditions	Min.	Max.	Unit
$V_{\text{DD}}$	Power Supply Voltage		-0.5	6	V
$I_{\text{VDD}}$	Current into a $V_{\text{DD}}$ pin	$T = [-40, 85]^{\circ}\text{C}$	-	200	mA
		$T = [85, 125]^{\circ}\text{C}$	-	100	mA
$I_{\text{GND}}$	Current out of a GND pin	$T = [-40, 85]^{\circ}\text{C}$	-	200	mA
		$T = [85, 125]^{\circ}\text{C}$	-	100	mA
$V_{\text{RST}}$	RESET pin voltage with respect to GND		-0.5	13	V
$V_{\text{PIN}}$	Pin voltage with respect to GND		-0.5	$V_{\text{DD}} + 0.5$	V
$I_{\text{PIN}}$	I/O pin sink/source current		-40	40	mA
$I_{\text{c1}}^{(1)}$	I/O pin injection current except RESET pin	$V_{\text{pin}} < \text{GND} - 0.6\text{V}$ or $5.5\text{V} < V_{\text{pin}} \leq 6.1\text{V}$ $4.9\text{V} < V_{\text{DD}} \leq 5.5\text{V}$	-1	1	mA
$I_{\text{c2}}^{(1)}$	I/O pin injection current except RESET pin	$V_{\text{pin}} < \text{GND} - 0.6\text{V}$ or $V_{\text{pin}} \leq 5.5\text{V}$ $V_{\text{DD}} \leq 4.9\text{V}$	-15	15	mA
$I_{\text{ctot}}$	Sum of I/O pin injection current except RESET pin		-45	45	mA
$T_{\text{storage}}$	Storage temperature		-65	150	$^{\circ}\text{C}$

**Note:**

1. – If  $V_{\text{PIN}}$  is lower than  $\text{GND} - 0.6\text{V}$ , then a current limiting resistor is required. The negative DC injection current limiting resistor is calculated as  $R = (\text{GND} - 0.6\text{V} - V_{\text{pin}}) / I_{\text{CN}}$ .
- If  $V_{\text{PIN}}$  is greater than  $V_{\text{DD}} + 0.6\text{V}$ , then a current limiting resistor is required. The positive DC injection current limiting resistor is calculated as  $R = (V_{\text{pin}} - (V_{\text{DD}} + 0.6)) / I_{\text{CN}}$ .





$V_{RSTMAX} = 13V$

Care should be taken to avoid overshoot (overvoltage) when connecting the RESET pin to a 12V source. Exposing the pin to a voltage above the rated absolute maximum can activate the pin's ESD protection circuitry, which will remain activated until the voltage has been brought below approximately 10V. A 12V driver can keep the ESD protection in an activated state (if activated by an overvoltage condition) while driving currents through it, potentially causing permanent damage to the part.

### 37.3 General Operating Ratings

The device must operate within the ratings listed in this section in order for all other electrical characteristics and typical characteristics of the device to be valid.

**Table 37-2. General Operating Conditions**

Symbol	Description	Condition	Min.	Max.	Unit
$V_{DD}$	Operating Supply Voltage		1.8 <sup>(2)</sup>	5.5	V
T	Operating temperature range <sup>(1)</sup>	Standard temperature range	-40	105	°C
		Extended temperature range <sup>(3)</sup>	-40	125	

**Note:**

1. Refer to the device ordering codes for the device temperature range.
2. Operation ensured down to 1.8V or  $V_{BOD}$  with BODLEVEL0, whichever is lower.
3. Extended temperature range is only ensured down to 2.7V.

**Table 37-3. Operating Voltage and Frequency**

Symbol	Description	Condition	Min.	Max.	Unit
CLK_CPU	Operating system clock frequency	$V_{DD}=[1.8, 5.5]V$ $T=[-40, 105]^{\circ}C^{(1)}$	0	5	MHz
		$V_{DD}=[2.7, 5.5]V$ $T=[-40, 105]^{\circ}C^{(2)}$	0	10	
		$V_{DD}=[4.5, 5.5]V$ $T=[-40, 105]^{\circ}C^{(3)}$	0	20	
		$V_{DD}=[2.7, 5.5]V$ $T=[-40, 125]^{\circ}C^{(2)}$	0	8	
		$V_{DD}=[4.5, 5.5]V$ $T=[-40, 125]^{\circ}C^{(3)}$	0	16	

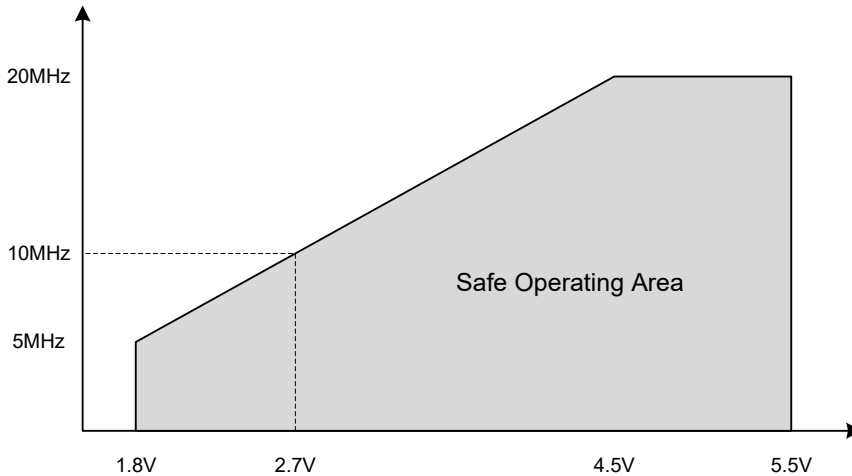
**Note:**

1. Operation ensured down to BOD triggering level,  $V_{BOD}$  with BODLEVEL0.

2. Operation ensured down to BOD triggering level,  $V_{BOD}$  with BODLEVEL2.
3. Operation ensured down to BOD triggering level,  $V_{BOD}$  with BODLEVEL7.

The maximum CPU clock frequency depends on  $V_{DD}$ . As shown in the following figure, the Maximum Frequency vs.  $V_{DD}$  is linear between  $1.8V < V_{DD} < 2.7V$  and  $2.7V < V_{DD} < 4.5V$ .

**Figure 37-1. Maximum Frequency vs.  $V_{DD}$  for [-40, 105]°C**



### 37.4 Power Consumption for ATtiny1614

The values are measured power consumption under the following conditions, except where noted:

- $V_{DD}=3V$
- $T=25^{\circ}C$
- OSC20M used as system clock source, except where otherwise specified
- System power consumption measured with peripherals disabled and without I/O drive

**Table 37-4. Power Consumption in Active and Idle Mode**

Mode	Description	Condition	Min.	Typ.	Max.	Unit	
Active	Active power consumption	CLK_CPU=20 MHz (OSC20M) $V_{DD}=5V$	-	10.2	-	mA	
		CLK_CPU=10 MHz (OSC20M div2) $V_{DD}=5V$	-	5.5	-	mA	
			$V_{DD}=3V$	-	3.1	-	mA
		CLK_CPU=5 MHz (OSC20M div4)	$V_{DD}=5V$	-	3.2	-	mA
			$V_{DD}=3V$	-	1.8	-	mA
			$V_{DD}=2V$	-	1.2	-	mA
		CLK_CPU=32 KHz (OSCUPLP32K)	$V_{DD}=5V$	-	13.5	-	$\mu A$
$V_{DD}=3V$	-		7.5	-	$\mu A$		
$V_{DD}=2V$	-		5.0	-	$\mu A$		
Idle	Idle power consumption	CLK_CPU=20 MHz (OSC20M) $V_{DD}=5V$	-	4.3	-	mA	

Mode	Description	Condition	Min.	Typ.	Max.	Unit	
		CLK_CPU=10 MHz (OSC20M div2)	V <sub>DD</sub> =5V	-	2.5	-	mA
			V <sub>DD</sub> =3V	-	1.4	-	mA
		CLK_CPU=5 MHz (OSC20M div4)	V <sub>DD</sub> =5V	-	1.6	-	mA
			V <sub>DD</sub> =3V	-	0.9	-	mA
			V <sub>DD</sub> =2V	-	0.6	-	mA
		CLK_CPU=32 KHz (OSCULP32K)	V <sub>DD</sub> =5V	-	8.2	-	μA
			V <sub>DD</sub> =3V	-	4.2	-	μA
			V <sub>DD</sub> =2V	-	2.6	-	μA

**Table 37-5. Power Consumption in Power-Down, Standby, and Reset Mode**

Mode	Description	Condition	Typ. 25°C	Max. 85°C	Max. 125°C	Unit	
Standby	Standby power consumption	RTC running at 1.024 kHz from external XOSC32K (CL=7.5 pF)	V <sub>DD</sub> =3V	0.69	-	-	μA
		RTC running at 1.024 kHz from internal OSCULP32K	V <sub>DD</sub> =3V	0.71	6.0	8.0	μA
Power Down/ Standby	Power-down/ Standby power consumption are the same when all peripherals are stopped	All peripherals stopped	V <sub>DD</sub> =3V	0.1	5.0	7.0	μA
Reset	Reset power consumption	Reset line pulled down	V <sub>DD</sub> =3V	100	-	-	μA

### Related Links

[37.6 Power Consumption of Peripherals](#)

## 37.5 Wake-Up Time

Wake-up time from Sleep mode is measured from the edge of the wake-up signal to the first instruction executed.

Operating conditions:

- V<sub>DD</sub> = 3V
- T = 25°C

- OSC20M as system clock source, unless otherwise specified

**Table 37-6. Start-Up, Reset, and Wake-Up Time from OSC20M**

Symbol	Description	Condition	Min.	Typ.	Max.	Unit
$t_{\text{wakeup}}$	Start-up time from any Reset release		-	200	-	$\mu\text{s}$
	Wake-up from Idle mode	OSC20M @ 20 MHz; $V_{\text{DD}}=5\text{V}$	-	1	-	
		OSC20M @ 10 MHz; $V_{\text{DD}}=3\text{V}$	-	2	-	
		OSC20M @ 5 MHz; $V_{\text{DD}}=2\text{V}$	-	4	-	
	Wake-up from Standby and Power-down mode		-	10	-	

### 37.6 Power Consumption of Peripherals

The table below can be used to calculate the additional current consumption for the different I/O peripherals in the various operating modes.

Operating conditions:

- $V_{\text{DD}} = 3\text{V}$
- $T = 25^{\circ}\text{C}$
- OSC20M at 1 MHz used as system clock source, except where otherwise specified
- In Idle Sleep mode, except where otherwise specified

**Table 37-7. Power Consumption of Peripherals**

Peripheral	Conditions	Typ. <sup>(1)</sup>	Unit
BOD	Continuous	19	$\mu\text{A}$
	Sampling @ 1 kHz	1.2	
TCA	16-bit count @ 1 MHz	12.6	$\mu\text{A}$
TCB	16-bit count @ 1 MHz	7.4	$\mu\text{A}$
RTC	16-bit count	1.2	$\mu\text{A}$
WDT		0.7	$\mu\text{A}$
OSC20M		125	$\mu\text{A}$
AC	Fast mode <sup>(2)</sup>	92	$\mu\text{A}$
	Low-power mode <sup>(2)</sup>	45	
ADC	50 ksps	325	$\mu\text{A}$
	100 ksps	340	
XOSC32K	$C_{\text{L}}=7.5\text{ pF}$	0.5	$\mu\text{A}$

Peripheral	Conditions	Typ. <sup>(1)</sup>	Unit
USART	Enable @ 9600 Baud	13	μA
SPI (Master)	Enable @ 100 kHz	2.1	μA
TWI (Master)	Enable @ 100 kHz	23.9	μA
TWI (Slave)	Enable @ 100 kHz	17.1	μA
Flash programming	Erase Operation	1.5	mA
	Write Operation	3.0	

**Note:**

1. Current consumption of the module only. To calculate the total power consumption of the system, add this value to the base power consumption as listed in *Power Consumption*.
2. CPU in Standby mode.

**Related Links**

[37.4 Power Consumption for ATtiny1614](#)

### 37.7 BOD and POR Characteristics

**Table 37-8. Power Supply Characteristics**

Symbol	Description	Condition	Min.	Typ.	Max.	Unit
SRON	Power-on Slope		-	-	100	V/ms

**Table 37-9. Power-On Reset (POR) Characteristics**

Symbol	Description	Condition	Min.	Typ.	Max.	Unit
VPOR	POR threshold voltage on V <sub>DD</sub> falling	V <sub>DD</sub> falls/rises at 0.5 V/ms or slower	0.8	-	1.6	V
	POR threshold voltage on V <sub>DD</sub> rising		1.4	-	1.8	

**Table 37-10. Brown-Out Detection (BOD) Characteristics**

Symbol	Description	Condition	Min.	Typ.	Max.	Unit
VBOD	BOD triggering level (falling/rising)	BODLEVEL7	3.9	4.2	4.5	V
		BODLEVEL2	2.4	2.6	2.9	
		BODLEVEL0	1.7	1.8	2.0	
VINT	Interrupt level 0	Percentage above the selected BOD level	-	4	-	%
	Interrupt level 1		-	13	-	
	Interrupt level 2		-	25	-	
VHYS	Hysteresis	BODLEVEL7	-	80	-	mV
		BODLEVEL2	-	40	-	
		BODLEVEL0	-	25	-	
TBOD	Detection time	Continuous	-	7	-	μs

Symbol	Description	Condition	Min.	Typ.	Max.	Unit
		Sampled, 1 kHz	-	1	-	ms
		Sampled, 125 Hz	-	8	-	
T <sub>start</sub>	Start-up time	Time from enable to ready	-	40	-	μs

### 37.8 External Reset Characteristics

**Table 37-11. External Reset Characteristics**

Mode	Description	Condition	Min.	Typ.	Max.	Unit
V <sub>HVRST</sub>	RESET pin threshold for high-voltage Reset		11.5	-	12.5	V
V <sub>RST_VIH</sub>	Input high-voltage for RESET		0.8×V <sub>DD</sub>	-	V <sub>DD</sub> +0.2	
V <sub>RST_VIL</sub>	Input low-voltage for RESET		-0.2	-	0.2×V <sub>DD</sub>	
t <sub>RST</sub>	Minimum pulse-width on RESET pin		-	-	2.5	μs
R <sub>RST</sub>	RESET pull-up resistor	V <sub>Reset</sub> =0V	20	-	60	kΩ

### 37.9 Oscillators and Clocks

Operating conditions:

- V<sub>DD</sub> = 3V, except where specified otherwise

**Table 37-12. Internal Oscillator (OSC20M) Characteristics**

Symbol	Description	Condition	Min.	Typ.	Max.	Unit	
f <sub>OSC20M</sub>	Accuracy with 16 MHz and 20 MHz frequency selection relative to the factory-stored frequency value	Factory calibrated V <sub>DD</sub> =3V <sup>(1)</sup>	T=[0, 70]°C, V <sub>DD</sub> =[1.8, 4.5]V <sup>(3)</sup>	-2.0	-	2.0	%
		Factory calibrated V <sub>DD</sub> =5V <sup>(1)</sup>	T=[0, 70]°C, V <sub>DD</sub> =[4.5, 5.5]V <sup>(3)</sup>	-2.0	-	2.0	
	Accuracy with 16 MHz and 20 MHz frequency selection	Factory calibrated	T=25°C, 3.0V	-3.0	-	3.0	%
			T=[0, 70]°C, V <sub>DD</sub> =[1.8, 3.6]V <sup>(3)</sup>	-4.0	-	4.0	
			Full operation range <sup>(3)</sup>	-5.0	-	5.0	
	f <sub>CAL</sub>	User calibration range	OSC20M <sup>(2)</sup> = 16 MHz		14.5	-	17.5
OSC20M <sup>(2)</sup> = 20 MHz				18.5	-	21.5	
%CAL	Calibration step size		-	1.5	-	%	
DC	Duty cycle		-	50	-	%	
T <sub>start</sub>	Start-up time	Within 2% accuracy	-	8	-	μs	

**Note:**

1. See the description of OSC20M on calibration.
2. Oscillator frequencies above speed specification must be divided so that CPU clock always is within specification.
3. These values are based on characterization and not covered by production test limits.

**Table 37-13. 32.768 kHz Internal Oscillator (OSCULP32K) Characteristics**

Symbol	Description	Condition	Condition	Min.	Typ.	Max.	Unit
$f_{\text{OSCULP32K}}$	Accuracy	Factory calibrated	T=25°C, 3.0V	-3	-	3	%
			T=[0, 70]°C, V <sub>DD</sub> =[1.8, 3.6]V <sup>(1)</sup>	-10	-	10	
			Full operation range <sup>(1)</sup>	-30	-	30	
DC	Duty cycle			-	50	-	%
T <sub>start</sub>	Start-up time			-	250	-	µs

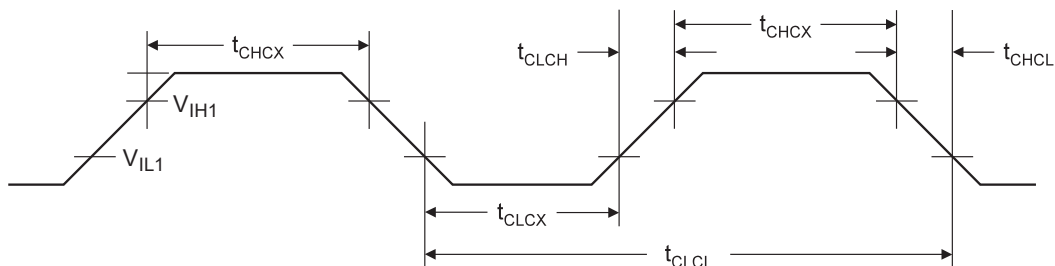
**Note:**

1. These values are based on characterization and not covered by production test limits.

**Table 37-14. 32.768 kHz External Crystal Oscillator (XOSC32K) Characteristics**

Symbol	Description	Condition	Min.	Typ.	Max.	Unit
F <sub>out</sub>	Frequency		-	32.768	-	kHz
T <sub>start</sub>	Start-up time	C <sub>L</sub> =7.5 pF	-	300	-	ms
C <sub>L</sub>	Crystal load capacitance		7.5	-	12.5	pF
CTOSC1	Parasitic capacitor load		-	5.5	-	pF
CTOSC2			-	5.5	-	pF
ESR	Equivalent Series Resistance - Safety Factor=3	C <sub>L</sub> =7.5 pF	-	-	80	kΩ
		C <sub>L</sub> =12.5 pF	-	-	40	

**Figure 37-2. External Clock Waveform Characteristics**



**Table 37-15. External Clock Characteristics**

Symbol	Description	Condition	V <sub>DD</sub> =[1.8, 5.5]V		V <sub>DD</sub> =[2.7, 5.5]V		V <sub>DD</sub> =[4.5, 5.5]V		Unit
			Min.	Max.	Min.	Max.	Min.	Max.	
f <sub>CLCL</sub>	Frequency		0	5.0	0.0	10.0	0.0	20.0	MHz
t <sub>CLCL</sub>	Clock Period		200	-	100	-	50	-	ns
t <sub>CHCX</sub>	High Time		80	-	40	-	20	-	ns
t <sub>CLCX</sub>	Low Time		80	-	40	-	20	-	ns

### 37.10 I/O Pin Characteristics

**Table 37-16. I/O Pin Characteristics (T<sub>A</sub>=[-40, 105]°C, V<sub>DD</sub>=[1.8, 5.5]V Unless Otherwise Noted)**

Symbol	Description	Condition	Min.	Typ.	Max.	Unit
V <sub>IL</sub>	Input low-voltage, except RESET pin as I/O		-0.2	-	0.3×V <sub>DD</sub>	V
V <sub>IH</sub>	Input high-voltage, except RESET pin as I/O		0.7×V <sub>DD</sub>	-	V <sub>DD</sub> +0.2V	V
I <sub>IH</sub> / I <sub>IL</sub>	I/O pin Input leakage current, except RESET pin as I/O	V <sub>DD</sub> =5.5V, Pin high	-	< 0.05	-	μA
		V <sub>DD</sub> =5.5V, Pin low	-	< 0.05	-	
V <sub>OL</sub>	I/O pin drive strength	V <sub>DD</sub> =1.8V, I <sub>OL</sub> =1.5 mA	-	-	0.36	V
		V <sub>DD</sub> =3.0V, I <sub>OL</sub> =7.5 mA	-	-	0.6	
		V <sub>DD</sub> =5.0V, I <sub>OL</sub> =15 mA	-	-	1	
V <sub>OH</sub>	I/O pin drive strength	V <sub>DD</sub> =1.8V, I <sub>OH</sub> =1.5 mA	1.44	-	-	V
		V <sub>DD</sub> =3.0V, I <sub>OH</sub> =7.5 mA	2.4	-	-	
		V <sub>DD</sub> =5.0V, I <sub>OH</sub> =15 mA	4	-	-	
I <sub>total</sub>	Maximum combined I/O sink current per pin group <sup>(1)</sup>		-	-	100	mA
	Maximum combined I/O source current per pin group <sup>(1)</sup>		-	-	100	
V <sub>IL2</sub>	Input low-voltage on RESET pin as I/O		-0.2	-	0.3×V <sub>DD</sub>	V
V <sub>IH2</sub>	Input high-voltage on RESET pin as I/O		0.7×V <sub>DD</sub>	-	V <sub>DD</sub> +0.2V	V
V <sub>OL2</sub>	I/O pin drive strength on RESET pin as I/O	V <sub>DD</sub> =1.8V, I <sub>OL</sub> =0.1 mA	-	-	0.36	V
		V <sub>DD</sub> =3.0V, I <sub>OL</sub> =0.25 mA	-	-	0.6	
		V <sub>DD</sub> =5.0V, I <sub>OL</sub> =0.5 mA	-	-	1	
V <sub>OH2</sub>	I/O pin drive strength on RESET pin as I/O	V <sub>DD</sub> =1.8V, I <sub>OH</sub> =0.1 mA	1.44	-	-	V
		V <sub>DD</sub> =3.0V, I <sub>OH</sub> =0.25 mA	2.4	-	-	
		V <sub>DD</sub> =5.0V, I <sub>OH</sub> =0.5 mA	4	-	-	
t <sub>RISE</sub>	Rise time	V <sub>DD</sub> =3.0V, load=20 pF	-	2.5	-	ns
		V <sub>DD</sub> =5.0V, load=20 pF	-	1.5	-	
t <sub>FALL</sub>	Fall time	V <sub>DD</sub> =3.0V, load=20 pF	-	2.0	-	ns
		V <sub>DD</sub> =5.0V, load=20 pF	-	1.3	-	
C <sub>pin</sub>	I/O pin capacitance except TOSC and TWI pins		-	3	-	pF



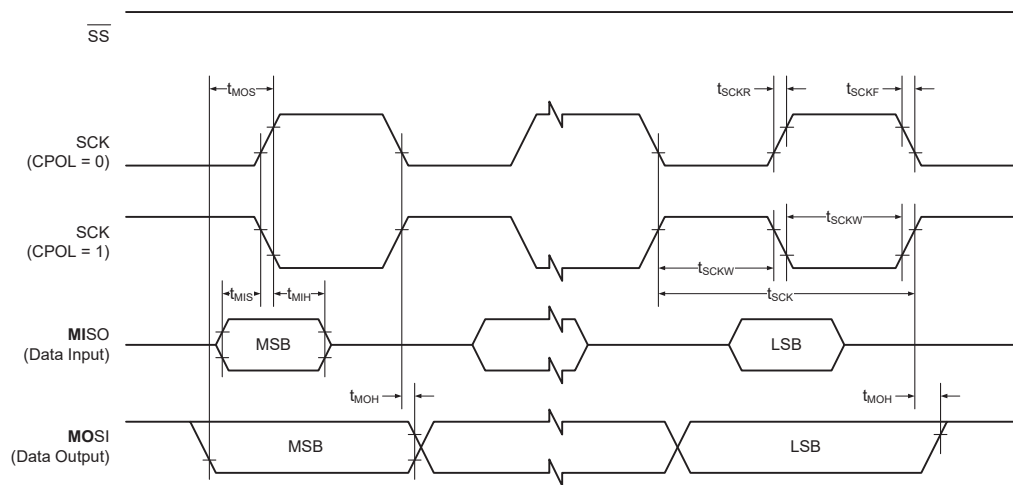
Symbol	Description	Condition	Min.	Typ.	Max.	Unit
C <sub>pin</sub>	I/O pin capacitance on TOSC pins		-	5.5	-	pF
C <sub>pin</sub>	I/O pin capacitance on TWI pins		-	10	-	pF
R <sub>p</sub>	Pull-up resistor		20	35	50	kΩ

**Note:**

- Pin group A (PA[7:0]), pin group B (PB[7:0]). The combined continuous sink/source current for all I/O ports should not exceed the limits.

### 37.11 USART

**Figure 37-3. USART in SPI Mode - Timing Requirements in Master Mode**

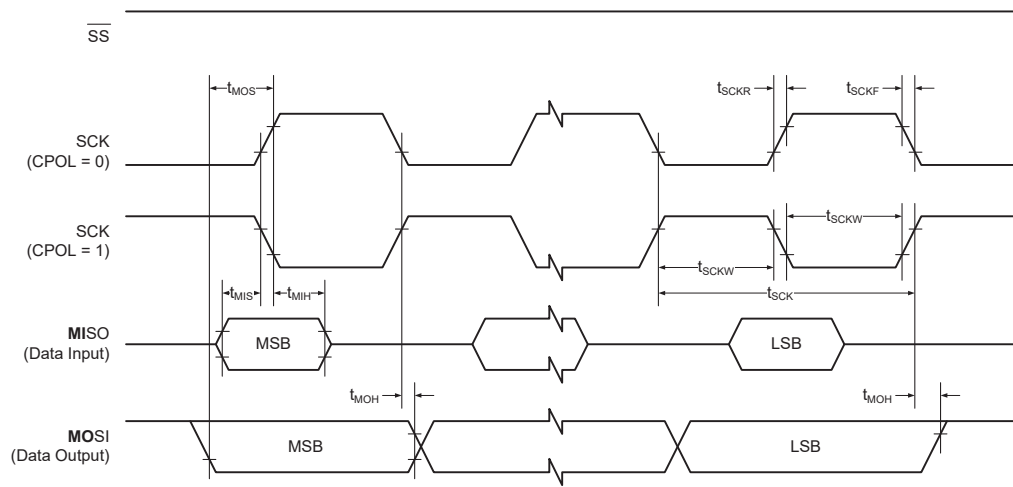


**Table 37-17. USART in SPI Master Mode - Timing Characteristics**

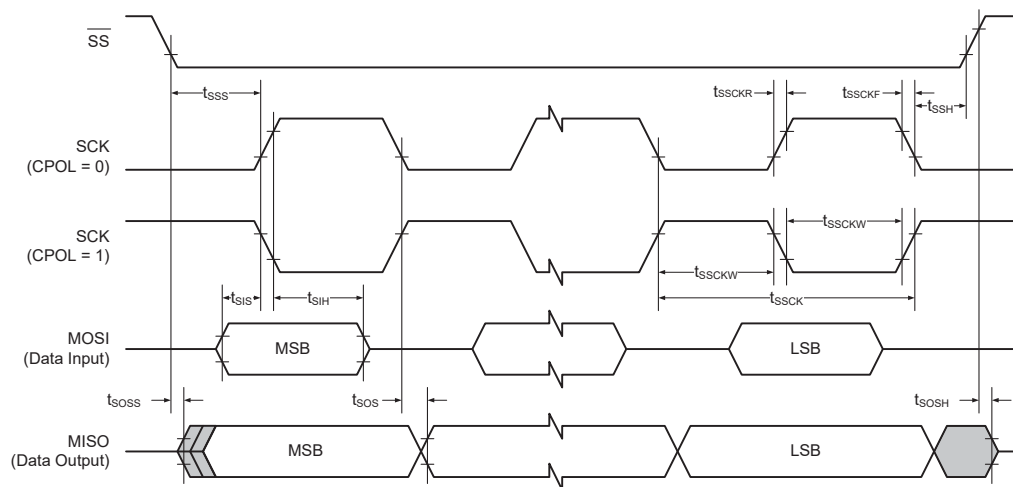
Symbol	Description	Condition	Min.	Typ.	Max.	Unit
f <sub>SCK</sub>	SCK clock frequency	Master	-	-	10	MHz
t <sub>SCK</sub>	SCK period	Master	100	-	-	ns
t <sub>SCKW</sub>	SCK high/low width	Master	-	0.5×t <sub>SCK</sub>	-	ns
t <sub>SCKR</sub>	SCK rise time	Master	-	2.7	-	ns
t <sub>SCKF</sub>	SCK fall time	Master	-	2.7	-	ns
t <sub>MIS</sub>	MISO setup to SCK	Master	-	10	-	ns
t <sub>MIH</sub>	MISO hold after SCK	Master	-	10	-	ns
t <sub>MOS</sub>	MOSI setup to SCK	Master	-	0.5×t <sub>SCK</sub>	-	ns
t <sub>MOH</sub>	MOSI hold after SCK	Master	-	1.0	-	ns

### 37.12 SPI

**Figure 37-4. SPI - Timing Requirements in Master Mode**



**Figure 37-5. SPI - Timing Requirements in Slave Mode**



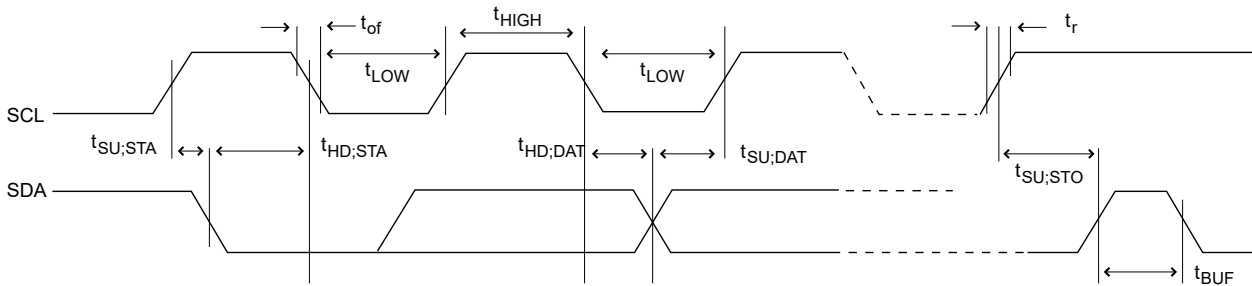
**Table 37-18. SPI - Timing Characteristics**

Symbol	Description	Condition	Min.	Typ.	Max.	Unit
$f_{SCK}$	SCK clock frequency	Master	-	-	10	MHz
$t_{SCK}$	SCK period	Master	100	-	-	ns
$t_{SCKW}$	SCK high/low width	Master	-	$0.5 \cdot SCK$	-	ns
$t_{SCKR}$	SCK rise time	Master	-	2.7	-	ns
$t_{SCKF}$	SCK fall time	Master	-	2.7	-	ns
$t_{MIS}$	MISO setup to SCK	Master	-	10	-	ns
$t_{MIH}$	MISO hold after SCK	Master	-	10	-	ns
$t_{MOS}$	MOSI setup to SCK	Master	-	$0.5 \cdot SCK$	-	ns
$t_{MOH}$	MOSI hold after SCK	Master	-	1.0	-	ns

Symbol	Description	Condition	Min.	Typ.	Max.	Unit
$f_{SSCK}$	Slave SCK clock frequency	Slave	-	-	5	MHz
$t_{SSCK}$	Slave SCK Period	Slave	$4 \cdot t_{Clkper}$	-	-	ns
$t_{SSCKW}$	SCK high/low width	Slave	$2 \cdot t_{Clkper}$	-	-	ns
$t_{SSCKR}$	SCK rise time	Slave	-	-	1600	ns
$t_{SSCKF}$	SCK fall time	Slave	-	-	1600	ns
$t_{SIS}$	MOSI setup to SCK	Slave	3.0	-	-	ns
$t_{SIH}$	MOSI hold after SCK	Slave	$t_{Clkper}$	-	-	ns
$t_{SSS}$	SS setup to SCK	Slave	21	-	-	ns
$t_{SSH}$	SS hold after SCK	Slave	20	-	-	ns
$t_{SOS}$	MISO setup to SCK	Slave	-	8.0	-	ns
$t_{SOH}$	MISO hold after SCK	Slave	-	13	-	ns
$t_{SOSS}$	MISO setup after SS low	Slave	-	11	-	ns
$t_{SOSH}$	MISO hold after SS low	Slave	-	8.0	-	ns

### 37.13 TWI

**Figure 37-6. TWI - Timing Requirements**



**Table 37-19. TWI - Timing Characteristics**

Symbol	Description	Condition	Min.	Typ.	Max.	Unit
$f_{SCL}$	SCL clock frequency	Max. frequency requires system clock at 10 MHz, which, in turn, requires $V_{DD}=[2.7, 5.5]V$ and $T=[-40, 105]^{\circ}C$	0	-	1000	kHz
$V_{IH}$	Input high voltage		$0.7 \times V_{DD}$	-	-	V
$V_{IL}$	Input low voltage		-	-	$0.3 \times V_{DD}$	V
$V_{HYS}$	Hysteresis of Schmitt trigger inputs		$0.1 \times V_{DD}$		$0.4 \times V_{DD}$	V

# ATTiny1614

## Electrical Characteristics

Symbol	Description	Condition	Min.	Typ.	Max.	Unit	
V <sub>OL</sub>	Output low voltage	I <sub>load</sub> =20 mA, Fast mode+	-	-	0.2V <sub>DD</sub>	V	
		I <sub>load</sub> =3 mA, Normal mode, V <sub>DD</sub> >2V	-	-	0.4V		
		I <sub>load</sub> =3 mA, Normal mode, V <sub>DD</sub> ≤2V	-	-	0.2×V <sub>DD</sub>		
I <sub>OL</sub>	Low-level output current	f <sub>SCL</sub> ≤400 kHz, V <sub>OL</sub> =0.4V	3	-	-	mA	
		f <sub>SCL</sub> ≤1 MHz, V <sub>OL</sub> =0.4V	20	-	-		
C <sub>B</sub>	Capacitive load for each bus line	f <sub>SCL</sub> ≤100 kHz	-	-	400	pF	
		f <sub>SCL</sub> ≤400 kHz	-	-	400		
		f <sub>SCL</sub> ≤1 MHz	-	-	550		
t <sub>R</sub>	Rise time for both SDA and SCL	f <sub>SCL</sub> ≤100 kHz	-	-	1000	ns	
		f <sub>SCL</sub> ≤400 kHz	20	-	300		
		f <sub>SCL</sub> ≤1 MHz	-	-	120		
t <sub>OF</sub>	Output fall time from V <sub>IHmin</sub> to V <sub>ILmax</sub>	10 pF < Capacitance of bus line < 400 pF	f <sub>SCL</sub> ≤400 kHz	20+0.1×C <sub>B</sub>	-	300	ns
		f <sub>SCL</sub> ≤1 MHz	20+0.1×C <sub>B</sub>	-	120		
t <sub>SP</sub>	Spikes suppressed by Input filter		0	-	50	ns	
I <sub>L</sub>	Input current for each I/O pin	0.1×V <sub>DD</sub> <V <sub>I</sub> <0.9×V <sub>DD</sub>	-	-	1	μA	
C <sub>I</sub>	Capacitance for each I/O pin		-	-	10	pF	
R <sub>P</sub>	Value of pull-up resistor	f <sub>SCL</sub> ≤100 kHz	(V <sub>DD</sub> -V <sub>OL(max)</sub> ) / I <sub>OL</sub>	-	1000 ns / (0.8473×C <sub>B</sub> )	Ω	
		f <sub>SCL</sub> ≤400 kHz	-	-	300 ns / (0.8473×C <sub>B</sub> )		
		f <sub>SCL</sub> ≤1 MHz	-	-	120 ns / (0.8473×C <sub>B</sub> )		
t <sub>HD;STA</sub>	Hold time (repeated) Start condition	f <sub>SCL</sub> ≤100 kHz	4.0	-	-	μs	
		f <sub>SCL</sub> ≤400 kHz	0.6	-	-		
		f <sub>SCL</sub> ≤1 MHz	0.26	-	-		
t <sub>LOW</sub>	Low period of SCL Clock	f <sub>SCL</sub> ≤100 kHz	4.7	-	-	μs	
		f <sub>SCL</sub> ≤400 kHz	1.3	-	-		
		f <sub>SCL</sub> ≤1 MHz	0.5	-	-		

Symbol	Description	Condition	Min.	Typ.	Max.	Unit
$t_{HIGH}$	High period of SCL Clock	$f_{SCL} \leq 100$ kHz	4.0	-	-	$\mu$ s
		$f_{SCL} \leq 400$ kHz	0.6	-	-	
		$f_{SCL} \leq 1$ MHz	0.26	-	-	
$t_{SU;STA}$	Setup time for a repeated Start condition	$f_{SCL} \leq 100$ kHz	4.7	-	-	$\mu$ s
		$f_{SCL} \leq 400$ kHz	0.6	-	-	
		$f_{SCL} \leq 1$ MHz	0.26	-	-	
$t_{HD;DAT}$	Data hold time	$f_{SCL} \leq 100$ kHz	0	-	3.45	$\mu$ s
		$f_{SCL} \leq 400$ kHz	0	-	0.9	
		$f_{SCL} \leq 1$ MHz	0	-	0.45	
$t_{SU;DAT}$	Data setup time	$f_{SCL} \leq 100$ kHz	250	-	-	ns
		$f_{SCL} \leq 400$ kHz	100	-	-	
		$f_{SCL} \leq 1$ MHz	50	-	-	
$t_{SU;STO}$	Setup time for Stop condition	$f_{SCL} \leq 100$ kHz	4	-	-	$\mu$ s
		$f_{SCL} \leq 400$ kHz	0.6	-	-	
		$f_{SCL} \leq 1$ MHz	0.26	-	-	
$t_{BUF}$	Bus free time between a Stop and Start condition	$f_{SCL} \leq 100$ kHz	4.7	-	-	$\mu$ s
		$f_{SCL} \leq 400$ kHz	1.3	-	-	
		$f_{SCL} \leq 1$ MHz	0.5	-	-	

### 37.14 VREF

**Table 37-20. Internal Voltage Reference Characteristics**

Symbol	Description	Min.	Typ.	Max.	Unit
$t_{start}$	Start-up time	-	25	-	$\mu$ s
$V_{DDINT055V}$	Power supply voltage range for INT055V	1.8	-	5.5	V
$V_{DDINT11V}$	Power supply voltage range for INT11V	1.8	-	5.5	
$V_{DDINT15V}$	Power supply voltage range for INT15V	1.9	-	5.5	
$V_{DDINT25V}$	Power supply voltage range for INT25V	2.9	-	5.5	
$V_{DDINT43V}$	Power supply voltage range for INT43V	4.75	-	5.5	

**Table 37-21. ADC Internal Voltage Reference Characteristics<sup>(1)</sup>**

Symbol <sup>(2)</sup>	Description	Condition	Min.	Typ.	Max.	Unit
INT11V	Internal reference voltage	$V_{DD}=[1.8V, 3.6V]$ $T=[0 - 105]^{\circ}C$	-2.0		2.0	%
INT055V INT15V INT25V	Internal reference voltage	$V_{DD}=[1.8V, 3.6V]$ $T=[0 - 105]^{\circ}C$	-3.0		3.0	
INT055V INT11V INT15V INT25V INT43V	Internal reference voltage	$V_{DD}=[1.8V, 5.5V]$ $T=[-40 - 125]^{\circ}C$	-5.0		5.0	

**Note:**

1. These values are based on characterization and not covered by production test limits.
2. The symbols INTxxV refer to the respective values of the ADC0REFSEL and DAC0REFSEL bit fields in the VREF.CTRLA register.

**Table 37-22. DAC and AC Internal Voltage Reference Characteristics<sup>(1)</sup>**

Symbol <sup>(2)</sup>	Description	Condition	Min.	Typ.	Max.	Unit
INT055V INT11V INT15V INT25V	Internal reference voltage	$V_{DD}=[1.8V, 3.6V]$ $T=[0 - 105]^{\circ}C$	-3.0		3.0	%
INT055V INT11V INT15V INT25V INT43V	Internal reference voltage	$V_{DD}=[1.8V, 5.5V]$ $T=[-40 - 125]^{\circ}C$	-5.0		5.0	

**Note:**

1. These values are based on characterization and not covered by production test limits.
2. The symbols INTxxV refer to the respective values of the ADC0REFSEL and DAC0REFSEL bit fields in the VREF.CTRLA register.

### 37.15 ADC

Operating conditions:

- $V_{DD} = 1.8$  to  $5.5V$
- Temperature =  $-40^{\circ}C$  to  $125^{\circ}C$
- DUTYCYC = 25%

- $CLK_{ADC} = 13 * f_{ADC}$
- SAMPCAP is 10 pF for 0.55V reference, while it is set to 5 pF for  $V_{REF} \geq 1.1V$
- Applies for all allowed combinations of  $V_{REF}$  selections and Sample Rates unless otherwise noted

**Table 37-23. Power Supply, Reference, and Input Range**

Symbol	Description	Conditions	Min.	Typ.	Max.	Unit
$V_{DD}$	Supply voltage		1.8	-	5.5	V
$V_{REF}$	Reference voltage	REFSEL = Internal reference	0.55	-	$V_{DD}-0.4$	V
		REFSEL = $V_{DD}$	1.8	-	5.5	
$C_{IN}$	Input capacitance	SAMPCAP=5 pF	-	5	-	pF
		SAMPCAP=10 pF	-	10	-	
$V_{IN}$	Input voltage range		0	-	$V_{REF}$	V
$I_{BAND}$	Input bandwidth	$1.1V \leq V_{REF}$	-	-	57.5	kHz

**Table 37-24. Clock and Timing Characteristics**

Symbol	Description	Conditions	Min.	Typ.	Max.	Unit
$f_{ADC}$	Sample rate	$1.1V \leq V_{REF}$	15	-	115	ksps
		$1.1V \leq V_{REF}$ (8-bit resolution)	15	-	150	
		$V_{REF}=0.55V$ (10 bits)	7.5	-	20	
$CLK_{ADC}$	Clock frequency	$V_{REF}=0.55V$ (10 bits)	100	-	260	kHz
		$1.1V \leq V_{REF}$ (10 bits)	200	-	1500	
		$1.1V \leq V_{REF}$ (8-bit resolution)	200	-	2000	
$T_s$	Sampling time		2	2	33	$CLK_{ADC}$ cycles
$T_{CONV}$	Conversion time (latency)	Sampling time = $2 CLK_{ADC}$	8.7	-	50	$\mu s$
$T_{START}$	Start-up time	Internal $V_{REF}$	-	22	-	$\mu s$

**Table 37-25. Accuracy Characteristics<sup>(2)</sup>**

Symbol	Description	Conditions	Min.	Typ.	Max.	Unit	
Res	Resolution		-	10	-	bit	
INL	Integral Nonlinearity	REFSEL = INTERNAL $V_{REF}=0.55V$	$f_{ADC}=7.7$ ksps	-	1.0	-	LSB
		REFSEL = INTERNAL or VDD	$f_{ADC}=15$ ksps	-	1.0	-	
			$f_{ADC}=77$ ksps	-	1.0	-	
		REFSEL = INTERNAL or VDD $1.1V \leq V_{REF}$	$f_{ADC}=115$ ksps	-	1.2	-	

Symbol	Description	Conditions	Min.	Typ.	Max.	Unit	
DNL <sup>(1)</sup>	Differential Nonlinearity	REFSEL = INTERNAL $V_{REF}=0.55V$	$f_{ADC}=7.7$ ksps	-	0.6	-	LSB
		REFSEL = INTERNAL or VDD	$f_{ADC}=15$ ksps	-	0.4	-	
		REFSEL = INTERNAL or VDD $1.1V \leq V_{REF}$	$f_{ADC}=77$ ksps	-	0.4	-	
		REFSEL = INTERNAL $1.1V \leq V_{REF}$	$f_{ADC}=115$ ksps	-	0.6	-	
		REFSEL = VDD $1.1V \leq V_{REF}$	$f_{ADC}=115$ ksps	-	0.6	-	
EABS	Absolute accuracy	REFSEL = INTERNAL $V_{REF} = 1.1V$	$T=[0-105]^{\circ}C$ $V_{DD} = [1.8V - 3.6V]$	-	3	-	LSB
			$V_{DD} = [1.8V - 3.6V]$	-	3	-	
		REFSEL = $V_{DD}$		-	2	-	
		REFSEL = INTERNAL		-	3	-	
EGAIN	Gain error	REFSEL = INTERNAL $V_{REF} = 1.1V$	$T=[0 - 105]^{\circ}C$ $V_{DD} = [1.8V - 3.6V]$	-	5	-	LSB
			$V_{DD} = [1.8V - 3.6V]$	-	5	-	
		REFSEL = $V_{DD}$		-	2	-	
		REFSEL =INTERNAL		-	5	-	
E0FF	Offset error			-	-0.5	-	LSB

**Note:**

1. A DNL error of less than or equal to 1 LSB ensures a monotonic transfer function with no missing codes.
2. These values are based on characterization and not covered by production test limits.
3. Reference setting and  $f_{ADC}$  must fulfill the specification in "Clock and Timing Characteristics" and "Power supply, Reference, and Input Range" tables.

### 37.16 DAC

$V_{DD}=3V$ , unless stated otherwise.



**Table 37-26. Power Supply, Reference, and Input Range**

Symbol	Description	Min.	Typ.	Max.	Unit
V <sub>DD</sub>	Supply Voltage <sup>(1)</sup>	1.8	3	5.5	V
R <sub>Load</sub>	Resistive External Load	5	-	-	kΩ
C <sub>Load</sub>	Capacitive External Load	-	-	30	pF
V <sub>OUT</sub>	Output Voltage Range	0.2	-	V <sub>DD</sub> -0.2	V
I <sub>OUT</sub>	Output sink/source	-	1	-	mA

**Note:** 1. Supply voltage must meet the V<sub>DD</sub> specification for the V<sub>REF</sub> level used as DAC reference.

**Table 37-27. Clock and Timing Characteristics**

Symbol	Description	Conditions	Min.	Typ.	Max.	Unit
f <sub>DAC</sub>	Maximum Conversion Rate	0.55V ≤ V <sub>REF</sub> ≤ 2.5V	-	350	-	ksps
		V <sub>REF</sub> = 4.3V	-	270	-	ksps

**Table 37-28. Accuracy Characteristics**

Symbol	Description	Conditions	Min.	Typ.	Max.	Unit
Res	Resolution		-		8	bits
INL	Integral Non-Linearity	0.55V ≤ V <sub>REF</sub> ≤ 4.3	-	0.3	-	LSB
DNL	Differential Non-Linearity	0.55V ≤ V <sub>REF</sub> ≤ 4.3	-	0.25	-	LSB
E <sub>OFF</sub>	Offset Error	V <sub>REF</sub> = 1.1V, V <sub>CC</sub> = 3.0 T = 25°C	-	±0.25	-	LSB
E <sub>GAIN</sub>	Gain Error	V <sub>REF</sub> = 1.1V, V <sub>CC</sub> = 3.0 T = 25°C	-	±1	-	LSB

### 37.17 AC

**Table 37-29. Analog Comparator Characteristics, Low-Power Mode Disabled**

Symbol	Description	Condition	Min.	Typ.	Max.	Unit
V <sub>IN</sub>	Input voltage		-0.2	-	V <sub>DD</sub>	V
C <sub>IN</sub>	Input pin capacitance	PA6	-	9	-	pF
		PA7, PB5, PB4	-	5	-	
V <sub>OFF</sub>	Input offset voltage	V <sub>IN</sub> = V <sub>DD</sub> /2	-20	<5	20	mV
		V <sub>IN</sub> = [-0.2V, V <sub>DD</sub> ]	-	<20	-	
I <sub>L</sub>	Input leakage current		-	5	-	nA
T <sub>START</sub>	Start-up time		-	1.3	-	μs
V <sub>HYS</sub>	Hysteresis	HYSMODE = 0x0	-	0	-	mV
		HYSMODE = 0x1	-	10	-	

Symbol	Description	Condition	Min.	Typ.	Max.	Unit
		HYSMODE=0x2	-	25	-	
		HYSMODE=0x3	-	50	-	
t <sub>PD</sub>	Propagation delay	25 mV Overdrive, V <sub>DD</sub> ≥2.7V, Low-Power mode disabled	-	50	-	ns

**Table 37-30. Analog Comparator Characteristics, Low-Power Mode Enabled**

Symbol	Description	Condition	Min.	Typ.	Max.	Unit
V <sub>IN</sub>	Input voltage		0	-	V <sub>DD</sub>	V
C <sub>IN</sub>	Input pin capacitance	PA6	-	9	-	pF
		PA7, PB5, PB4	-	5	-	
V <sub>OFF</sub>	Input offset voltage	V <sub>IN</sub> = V <sub>DD</sub> /2	-25	<10	25	mV
		V <sub>IN</sub> =[0V, V <sub>DD</sub> ]	-	<30	-	
I <sub>L</sub>	Input leakage current		-	5	-	nA
T <sub>START</sub>	Start-up time		-	1.3	-	μs
V <sub>HYS</sub>	Hysteresis,	HYSMODE=0x0	-	0	-	mV
		HYSMODE=0x1	-	10	-	
		HYSMODE=0x2	-	25	-	
		HYSMODE=0x3	-	50	-	
t <sub>PD</sub>	Propagation delay	25 mV Overdrive, V <sub>DD</sub> ≥2.7V	-	150	-	ns

### 37.18 PTC

**Table 37-31. Peripheral Touch Controller Characteristics - Operating Ratings**

Symbol	Description	Condition	Min.	Typ.	Max.	Unit
V <sub>DD</sub>	Supply Voltage		1.8	-	5.5	V
CLK <sub>PER</sub>	Peripheral Clock frequency		-	-	8	MHz
C <sub>LOAD</sub>	Maximum load		-	48	-	pF
C <sub>INT</sub>			-	30	-	pF
	Driven Shield Capacitive Drive		-	300	-	pF

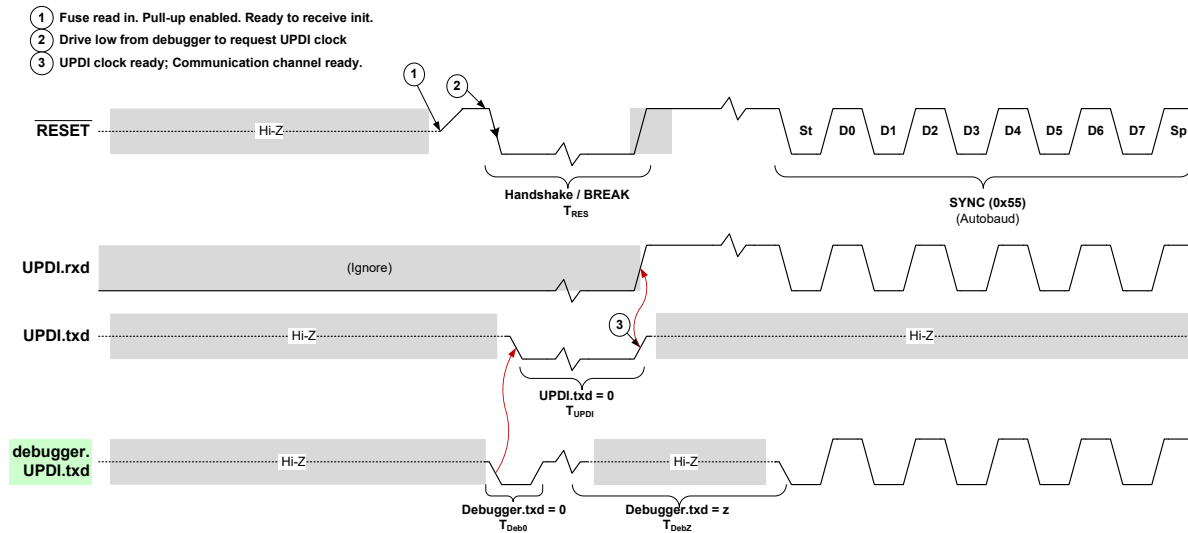
**Table 37-32. Peripheral Touch Controller Characteristics - Pad Capacitance**

Symbol	Description	Condition	Min.	Typ.	Max.	Unit
C <sub>Y</sub>	Pad Capacitance Yline	PA4, Y0	-	4	-	pF
		PA5, Y1	-	24	-	

Symbol	Description	Condition	Min.	Typ.	Max.	Unit
		PA6, Y2	-	9	-	
		PA7, Y3		6		
		PB5, Y12	-	4	-	
		PB4, Y13	-	4	-	
		PB1, Y4	-	13	-	
		PB0, Y5	-	13	-	
		PC0, Y6	-	6	-	
		PC1, Y7	-	6	-	
		PC2, Y8	-	6	-	
		PC3, Y9	-	6	-	
		PC4, Y10	-	6	-	
		PC5, Y11	-	6	-	

### 37.19 UPDI Timing

#### UPDI Enable Sequence with UPDI PAD Enabled by Fuse



Symbol	Description	Min.	Max.	Unit
$T_{RES}$	Duration of Handshake/Break on RESET	10	200	$\mu s$
$T_{UPDI}$	Duration of UPDI.txd=0	10	200	$\mu s$
$T_{Deb0}$	Duration of Debugger.txd=0	0.2	1	$\mu s$
$T_{DebZ}$	Duration of Debugger.txd=z	200	14000	$\mu s$

### Related Links

[33.3.2.1 UPDI Enable with Fuse Override of RESET Pin](#)

## 37.20 Programming Time

See the following table for typical programming times for Flash and EEPROM.

**Table 37-33. Programming Times**

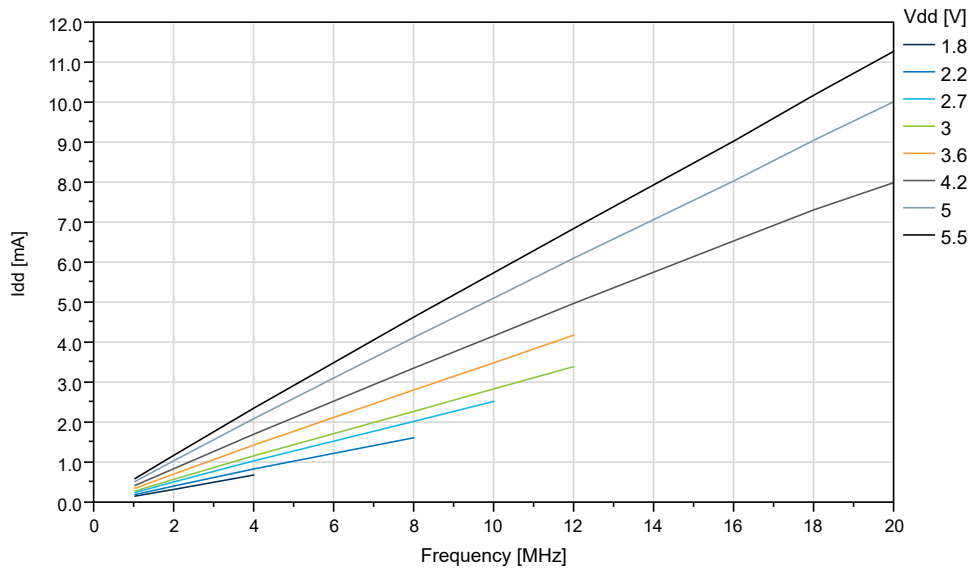
Symbol	Typical Programming Time
Page Buffer Clear	7 CLK_CPU cycles
Page Write	2 ms
Page Erase	2 ms
Page Erase-Write	4 ms
Chip Erase	4 ms
EEPROM Erase	4 ms

## 38. Typical Characteristics

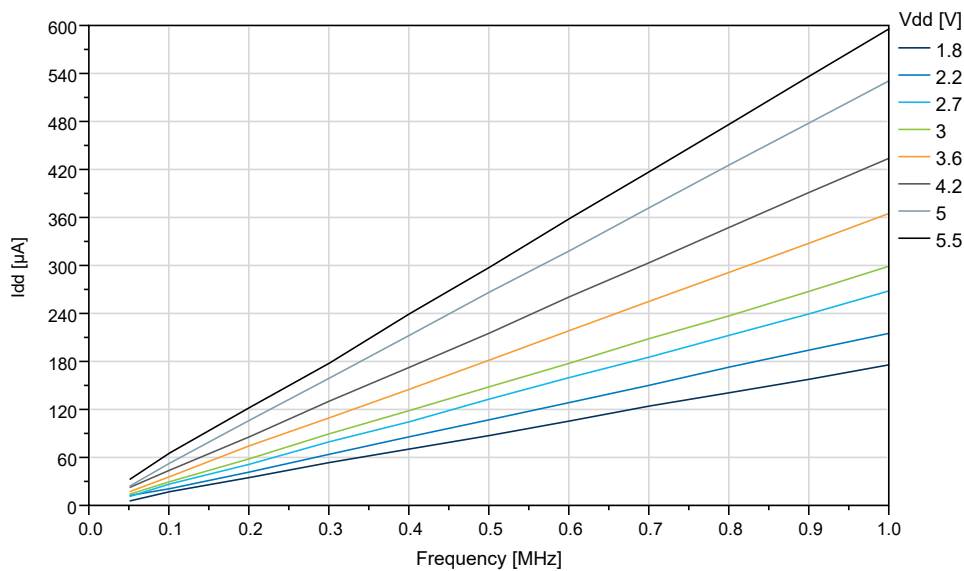
### 38.1 Power Consumption

#### 38.1.1 Supply Currents in Active Mode for ATtiny1614

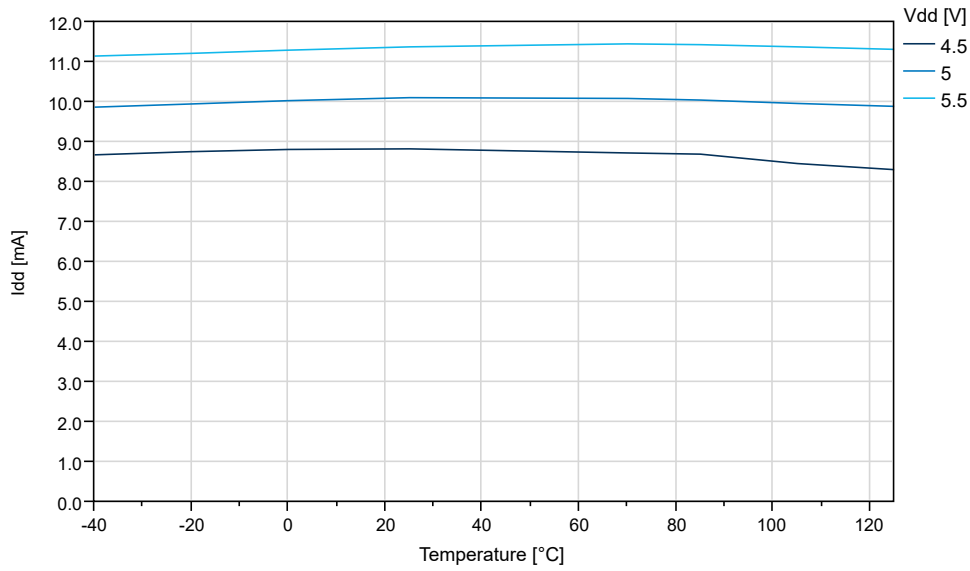
**Figure 38-1. ATtiny1614 Active Supply Current vs. Frequency (1-20 MHz) at T=25°C**



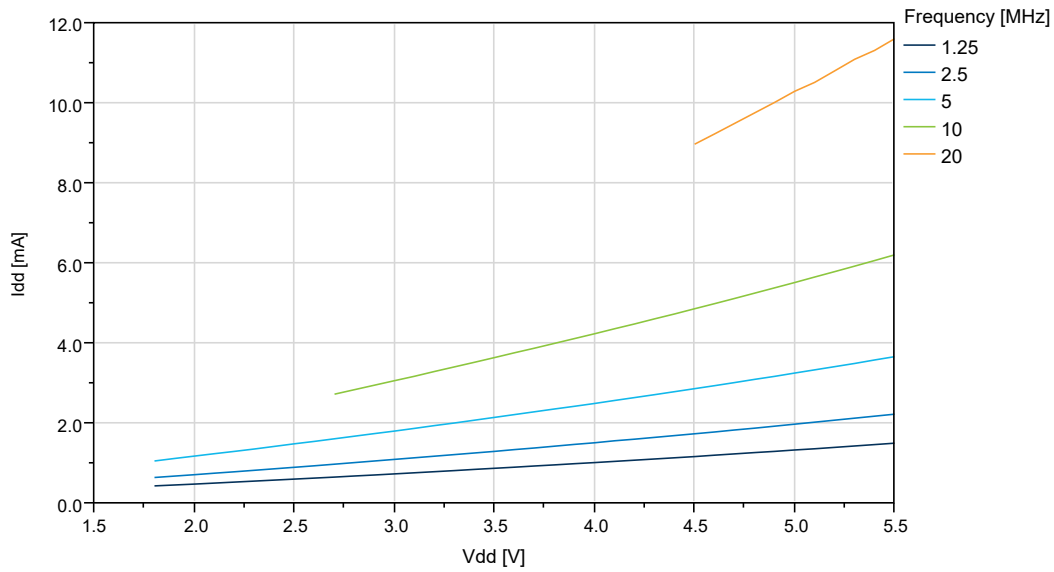
**Figure 38-2. ATtiny1614 Active Supply Current vs. Frequency [0.1, 1.0] MHz at T=25°C**



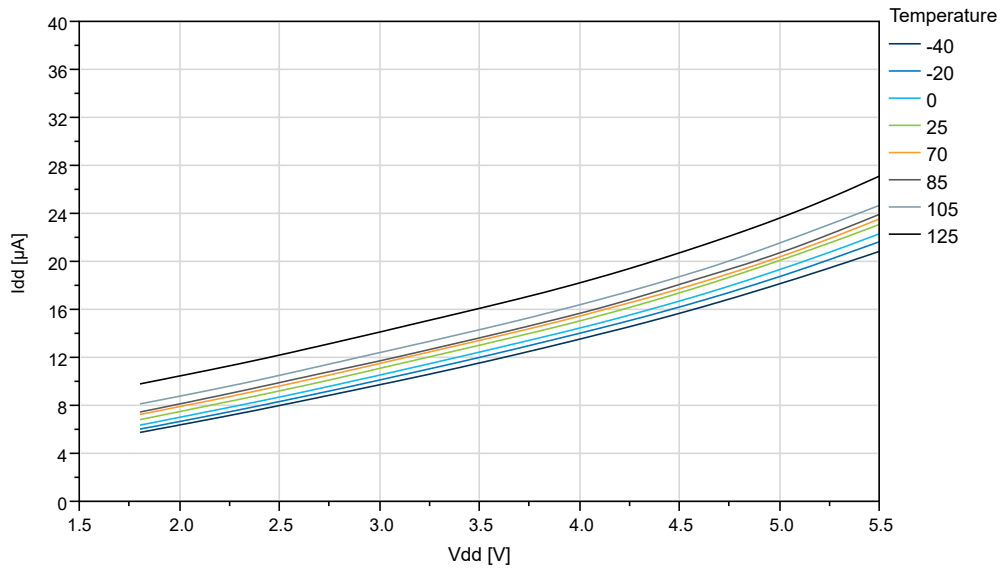
**Figure 38-3. ATtiny1614 Active Supply Current vs. Temperature (f=20 MHz OSC20M)**



**Figure 38-4. ATtiny1614 Active Supply Current vs. V<sub>DD</sub> (f=[1.25, 20] MHz OSC20M) at T=25°C**

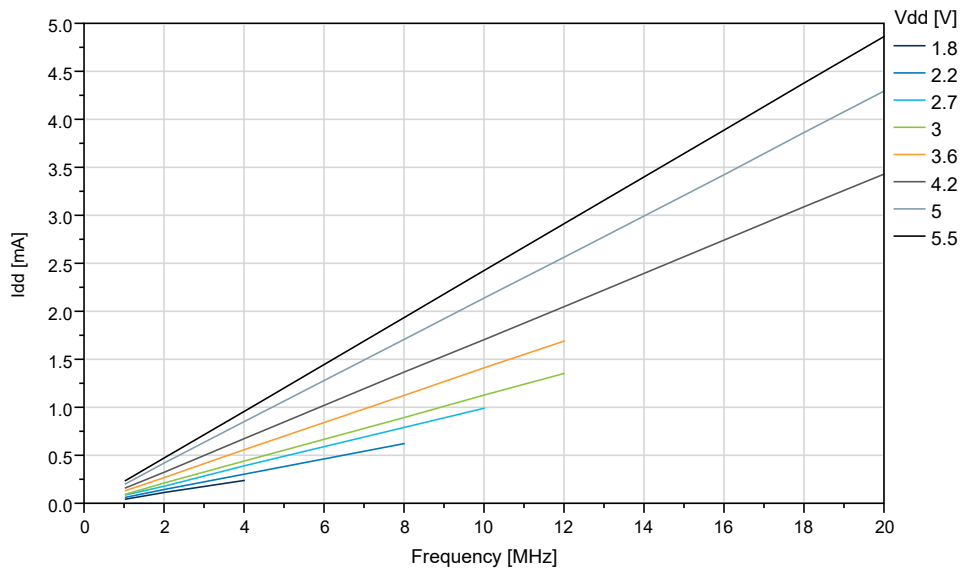


**Figure 38-5. ATtiny1614 Active Supply Current vs.  $V_{DD}$  (f=32 KHz OSCULP32K)**

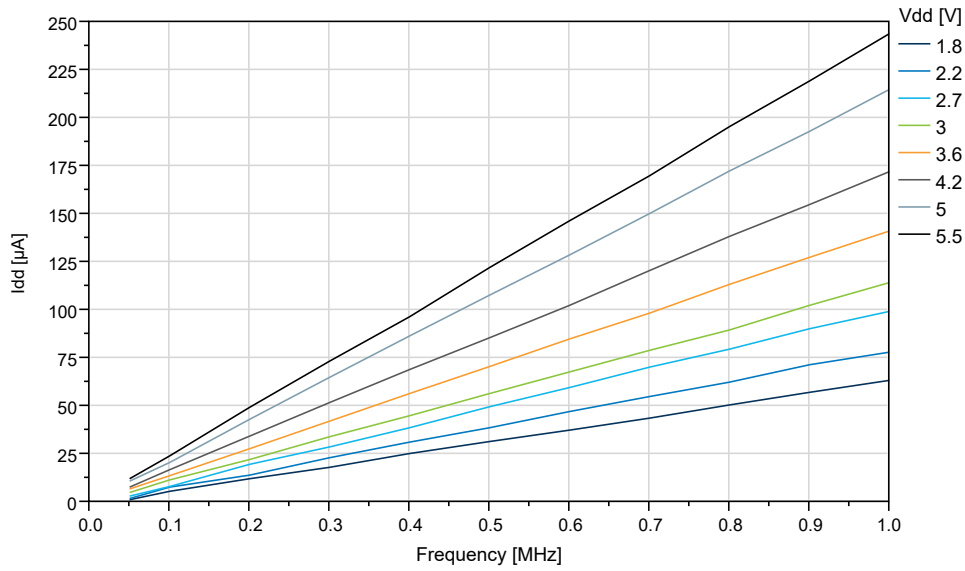


### 38.1.2 Supply Currents in Idle Mode for ATtiny1614

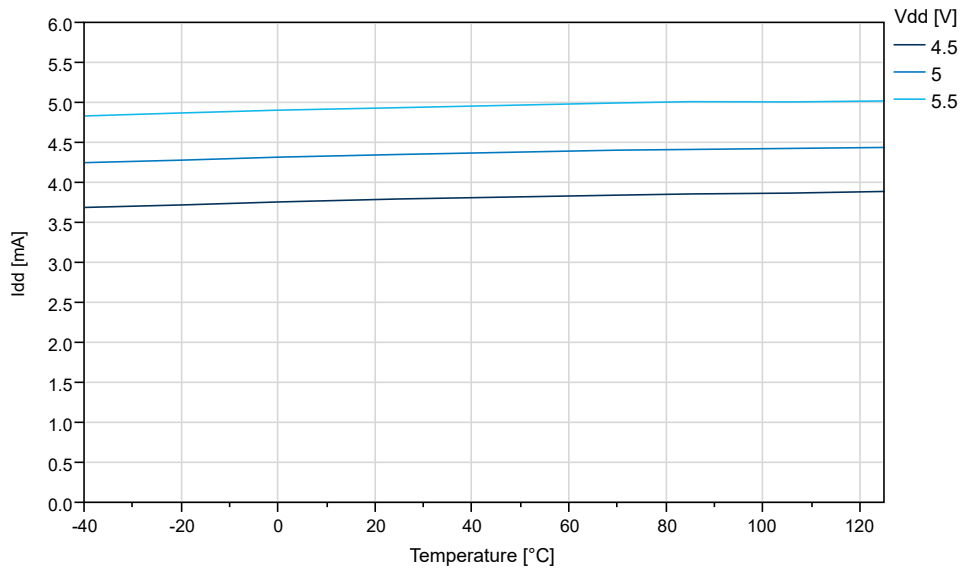
**Figure 38-6. ATtiny1614 Idle Supply Current vs. Frequency (1-20 MHz) at T=25°C**



**Figure 38-7. ATtiny1614 Idle Supply Current vs. Low Frequency (0.1-1.0 MHz) at T=25°C**

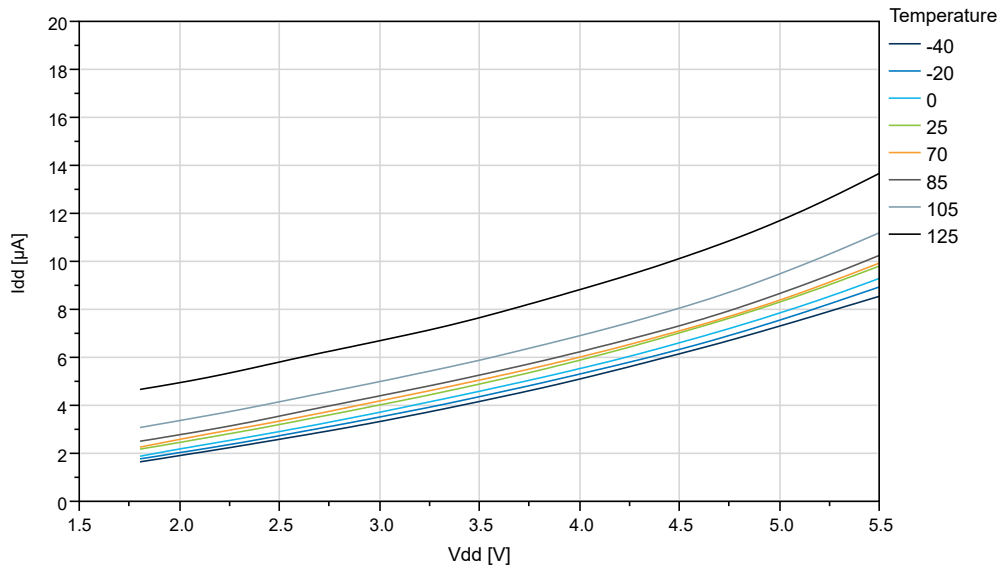


**Figure 38-8. ATtiny1614 Idle Supply Current vs. Temperature (f=20 MHz OSC20M)**



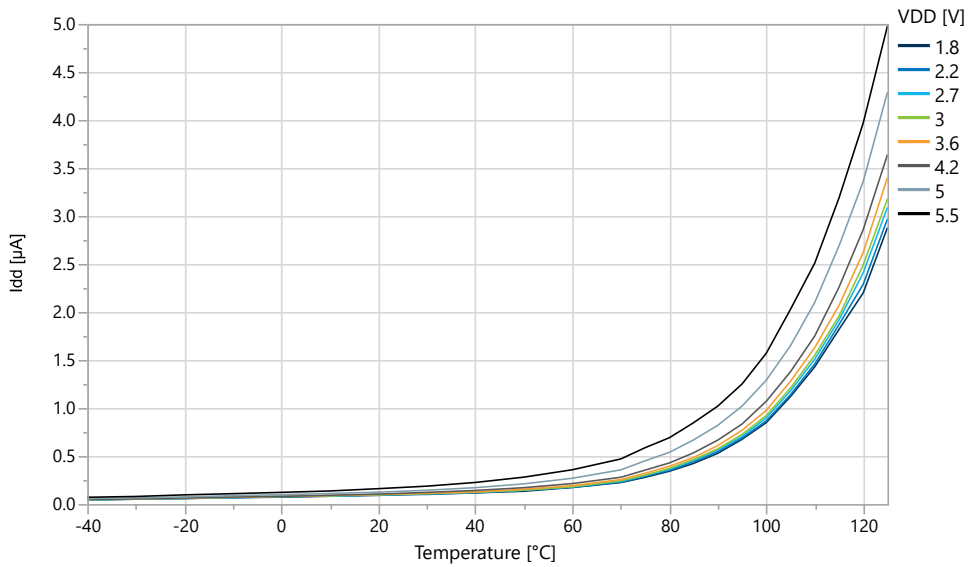


**Figure 38-9. ATtiny1614 Idle Supply Current vs.  $V_{DD}$  (f=32 KHz OSCULP32K)**

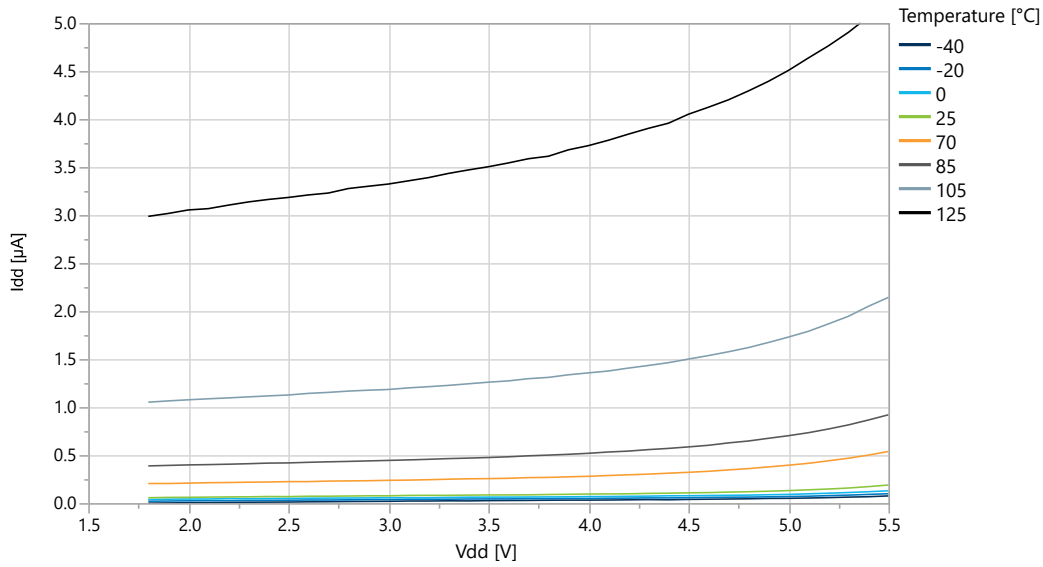


### 38.1.3 Supply Currents in Power-Down Mode for ATtiny1614

**Figure 38-10. ATtiny1614 Power-Down Mode Supply Current vs. Temperature (all functions disabled)**

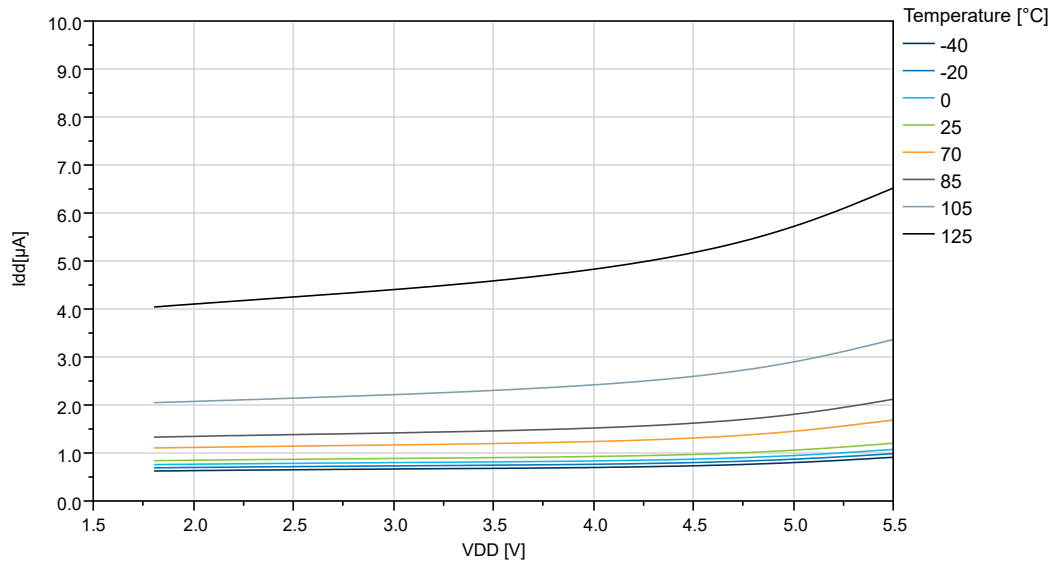


**Figure 38-11. ATtiny1614 Power-Down Mode Supply Current vs.  $V_{DD}$  (all functions disabled)**

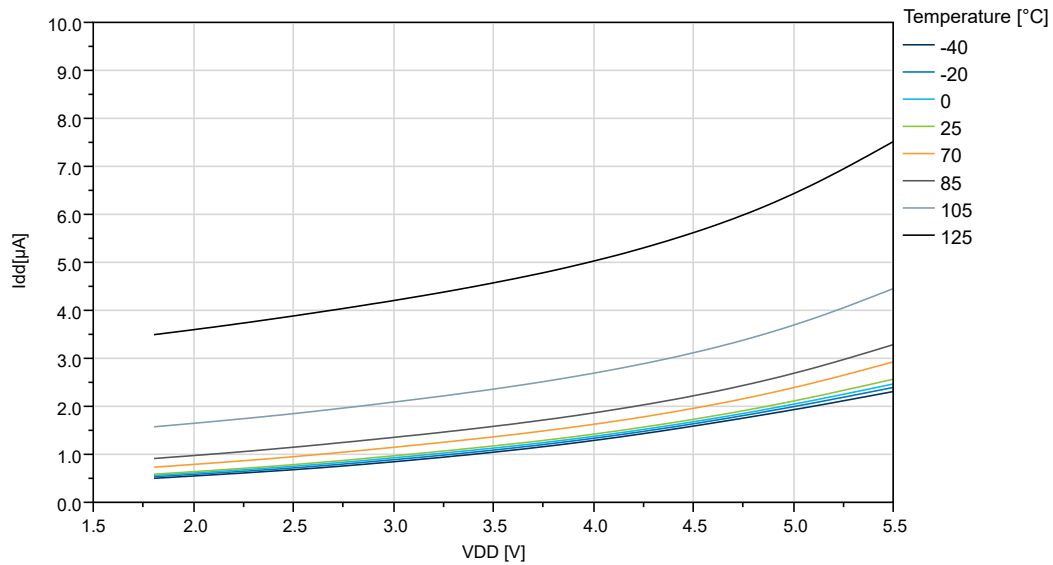


### 38.1.4 Supply Currents in Standby Mode for ATtiny1614

**Figure 38-12. ATtiny1614 Standby Mode Supply Current vs.  $V_{DD}$  (RTC Running with External 32 KHz Osc.)**



**Figure 38-13. ATtiny1614 Standby Mode Supply Current vs.  $V_{DD}$  (RTC Running with Internal OSCULP32K)**



**Figure 38-14. ATtiny1614 Standby Mode Supply Current vs.  $V_{DD}$  (Sampled BOD Running at 125 Hz)**

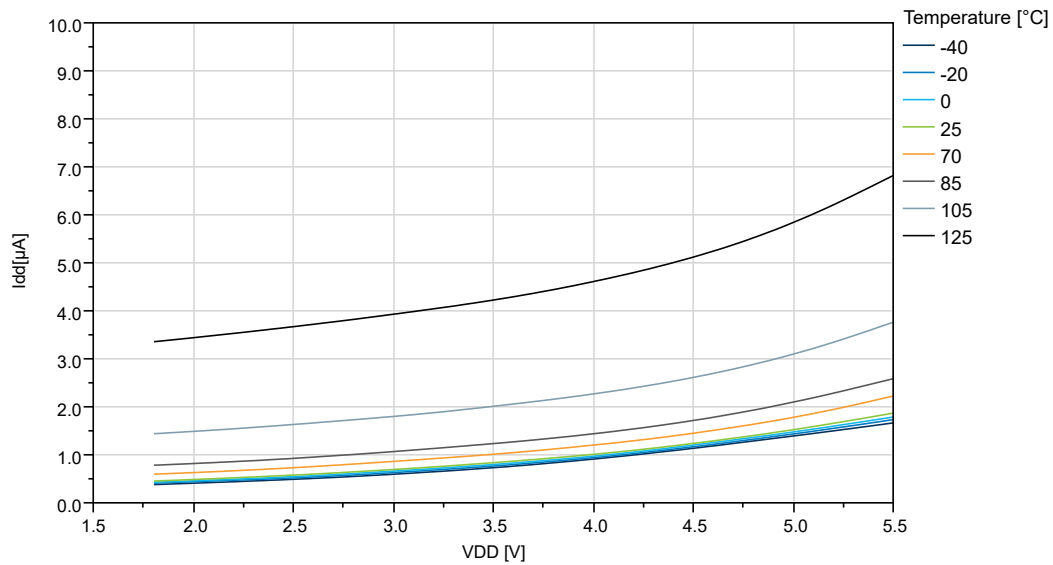
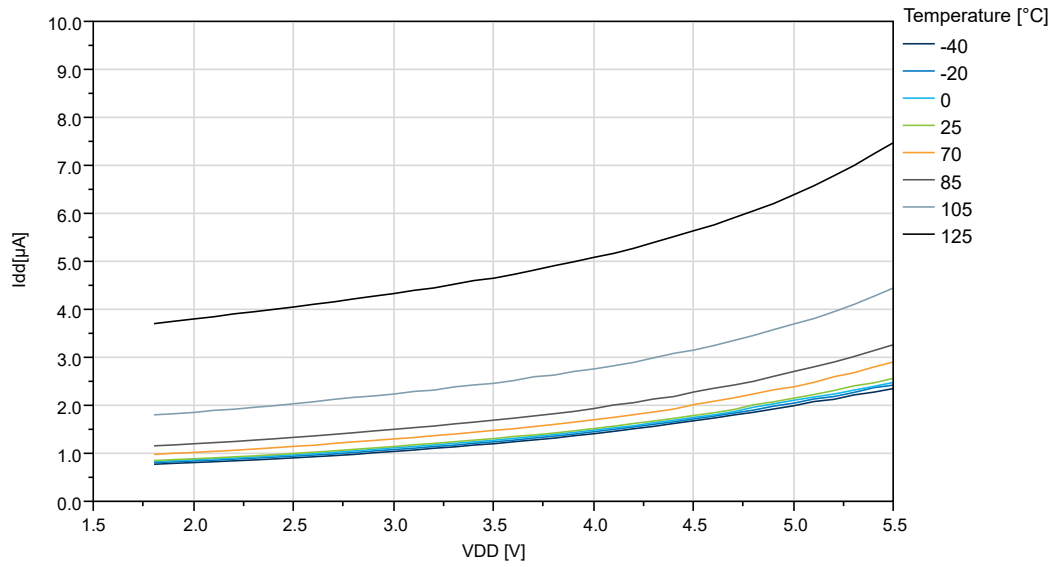


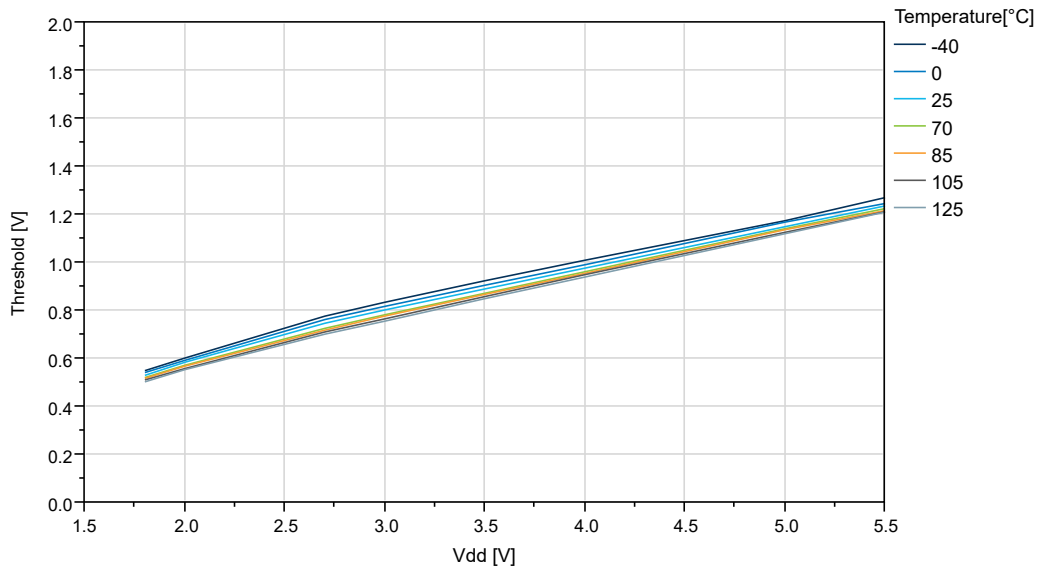
Figure 38-15. ATtiny1614 Standby Mode Supply Current vs.  $V_{DD}$  (Sampled BOD Running at 1 kHz)



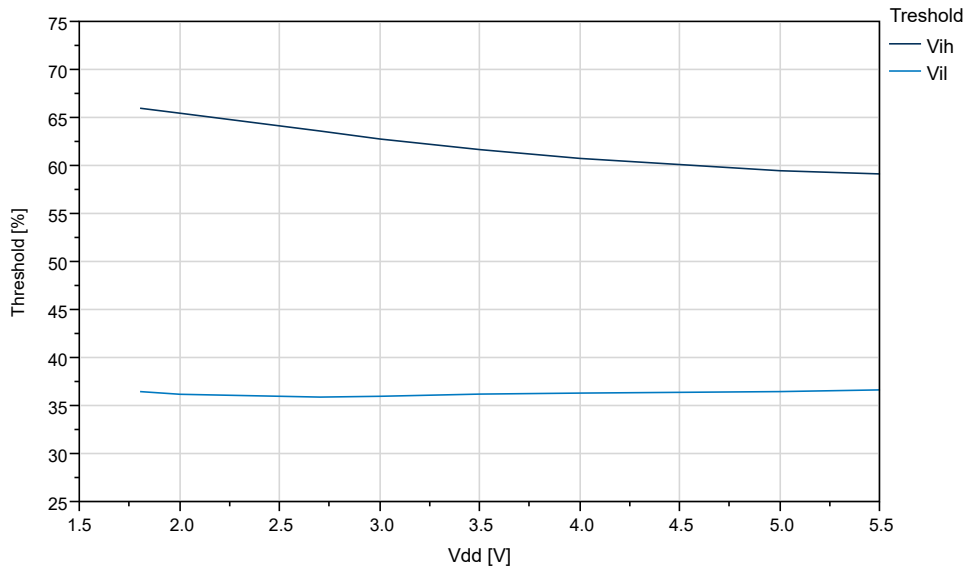
## 38.2 GPIO

### GPIO Input Characteristics

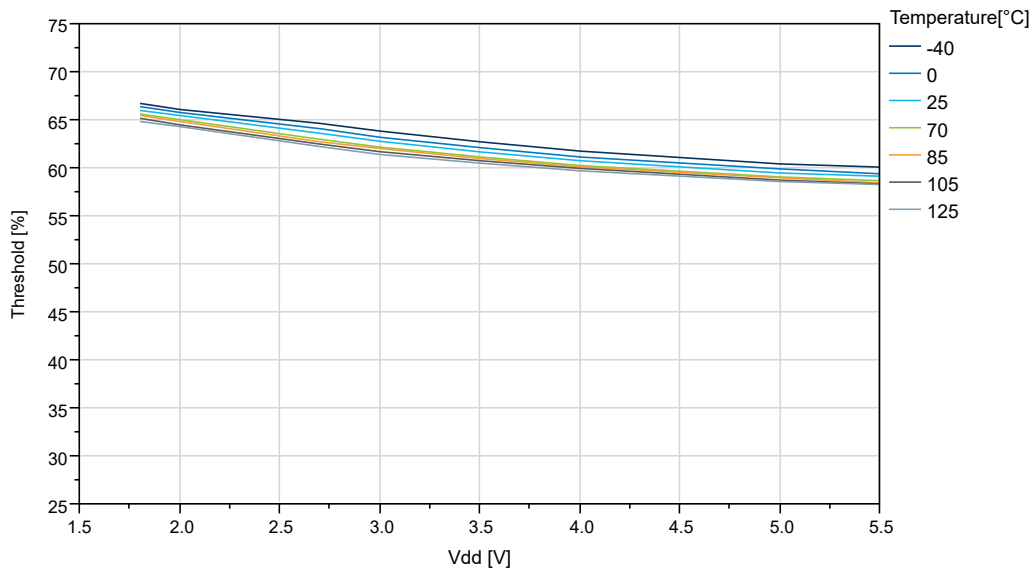
Figure 38-16. I/O Pin Input Hysteresis vs.  $V_{DD}$



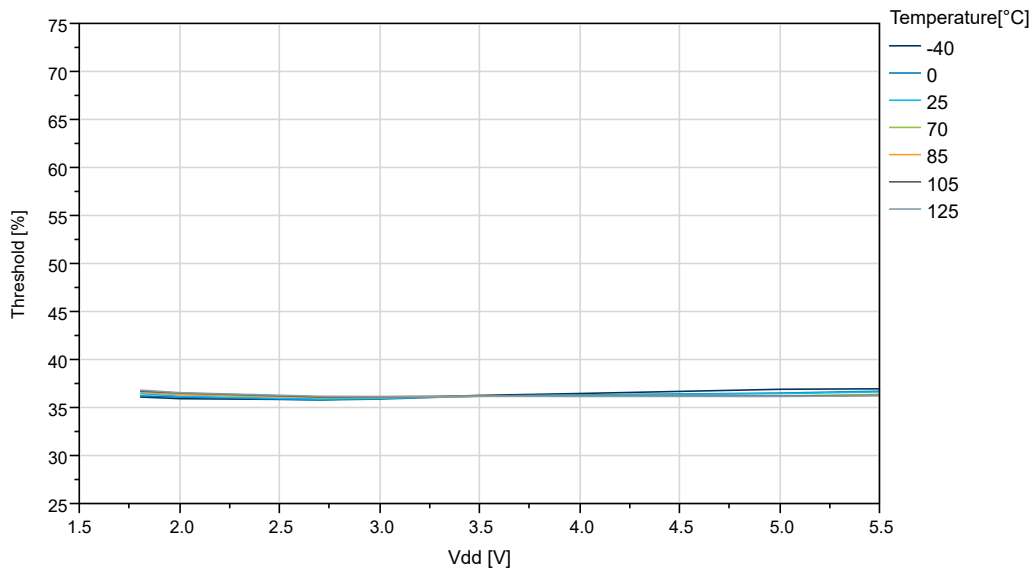
**Figure 38-17. I/O Pin Input Threshold Voltage vs.  $V_{DD}$  ( $T=25^{\circ}\text{C}$ )**



**Figure 38-18. I/O Pin Input Threshold Voltage vs.  $V_{DD}$  ( $V_{IH}$ )**

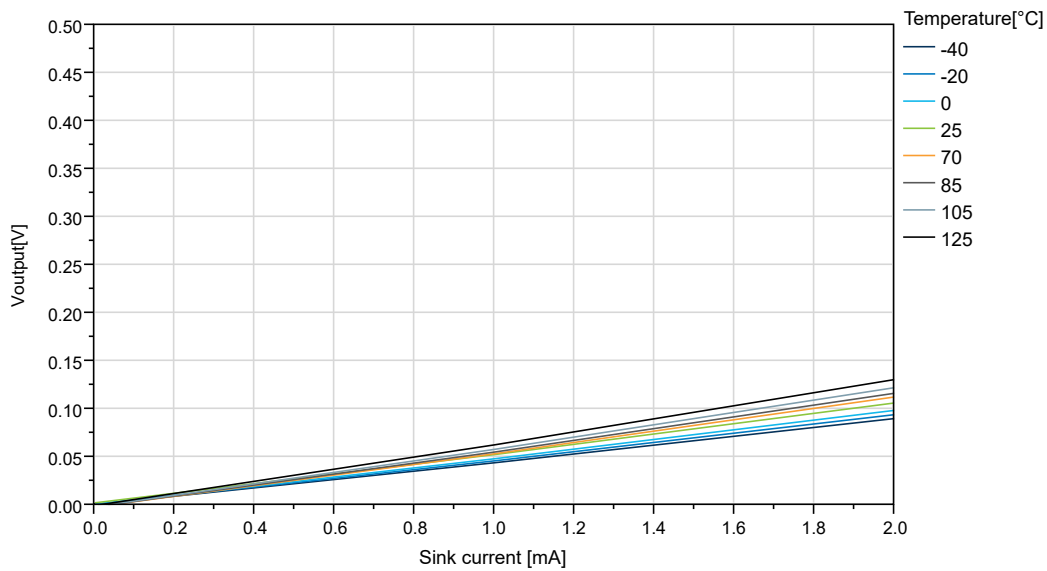


**Figure 38-19. I/O Pin Input Threshold Voltage vs.  $V_{DD}$  ( $V_{IL}$ )**

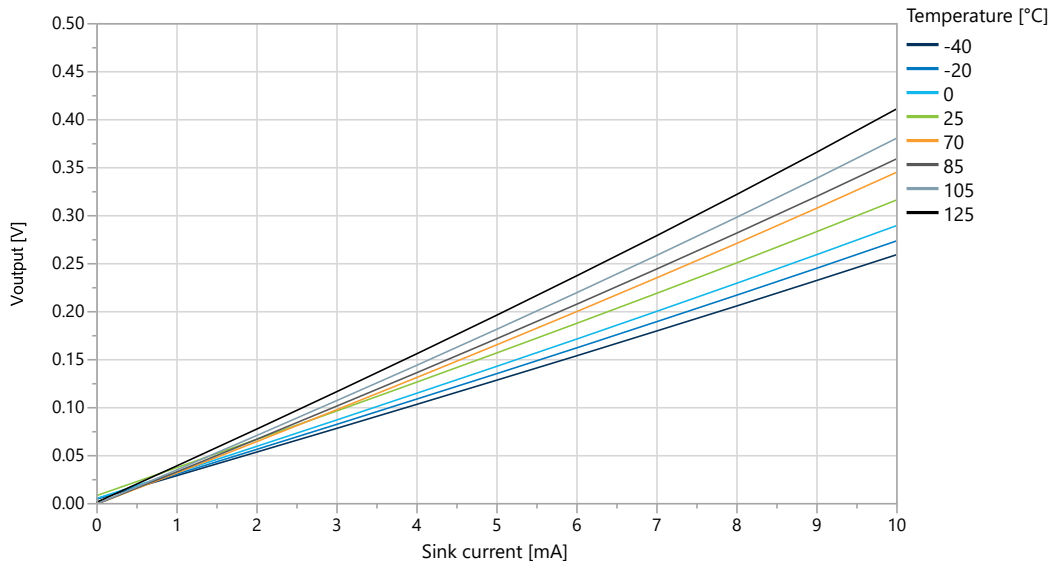


### GPIO Output Characteristics

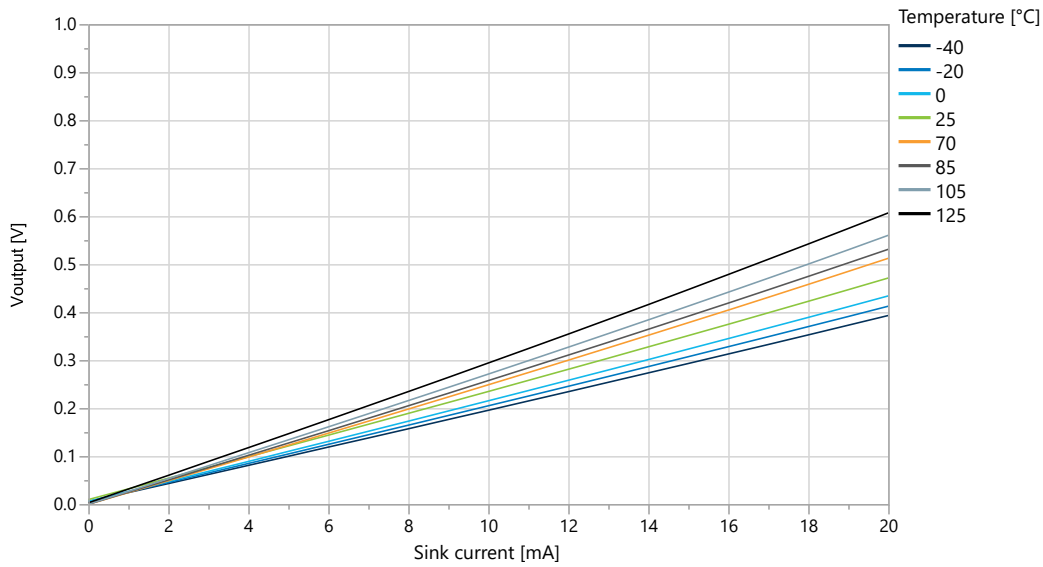
**Figure 38-20. I/O Pin Output Voltage vs. Sink Current ( $V_{DD}=1.8V$ )**



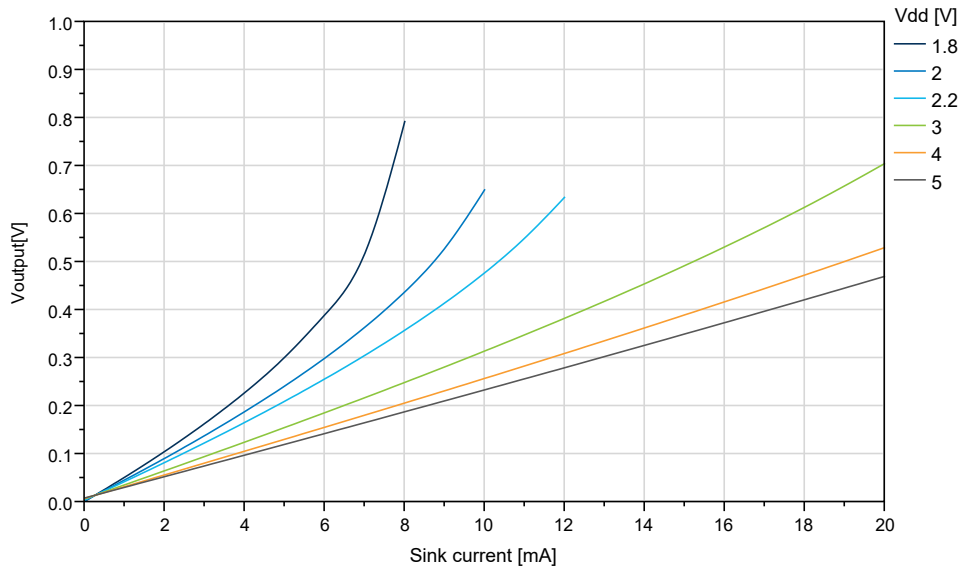
**Figure 38-21. I/O Pin Output Voltage vs. Sink Current ( $V_{DD}=3.0V$ )**



**Figure 38-22. I/O Pin Output Voltage vs. Sink Current ( $V_{DD}=5.0V$ )**



**Figure 38-23. I/O Pin Output Voltage vs. Sink Current (T=25°C)**



**Figure 38-24. I/O Pin Output Voltage vs. Source Current (V<sub>DD</sub>=1.8V)**

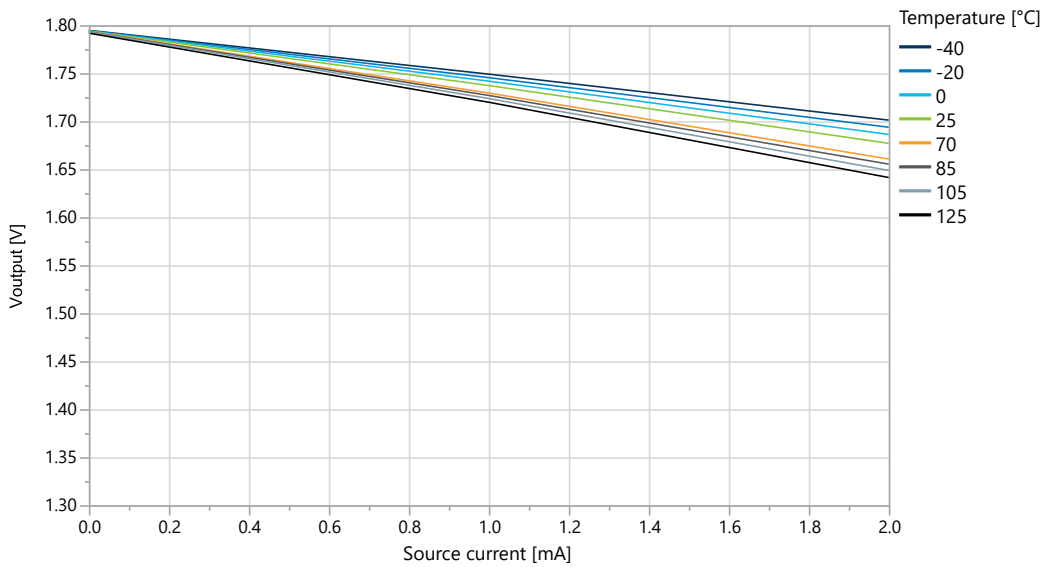




Figure 38-25. I/O Pin Output Voltage vs. Source Current ( $V_{DD}=3.0V$ )

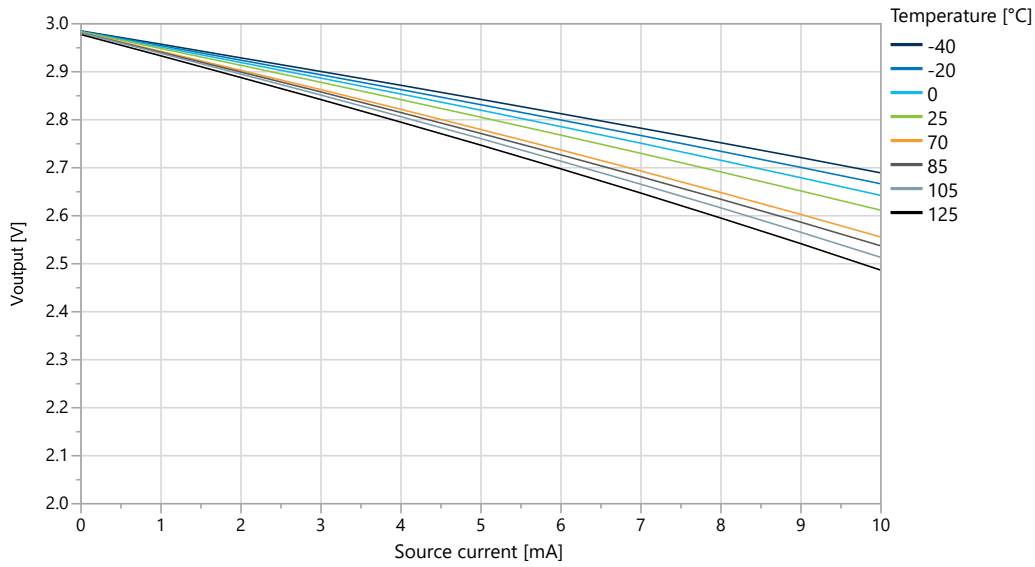
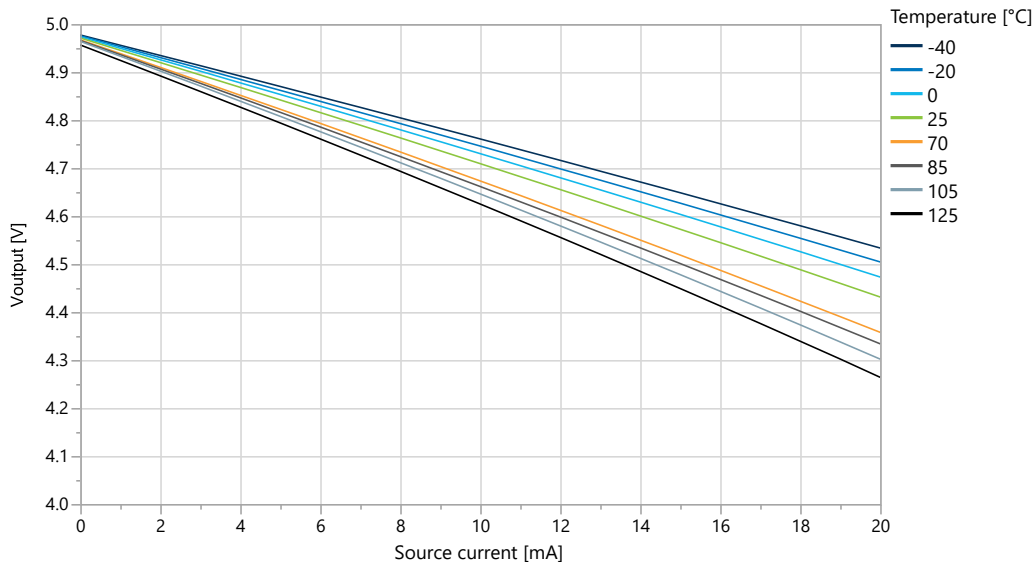
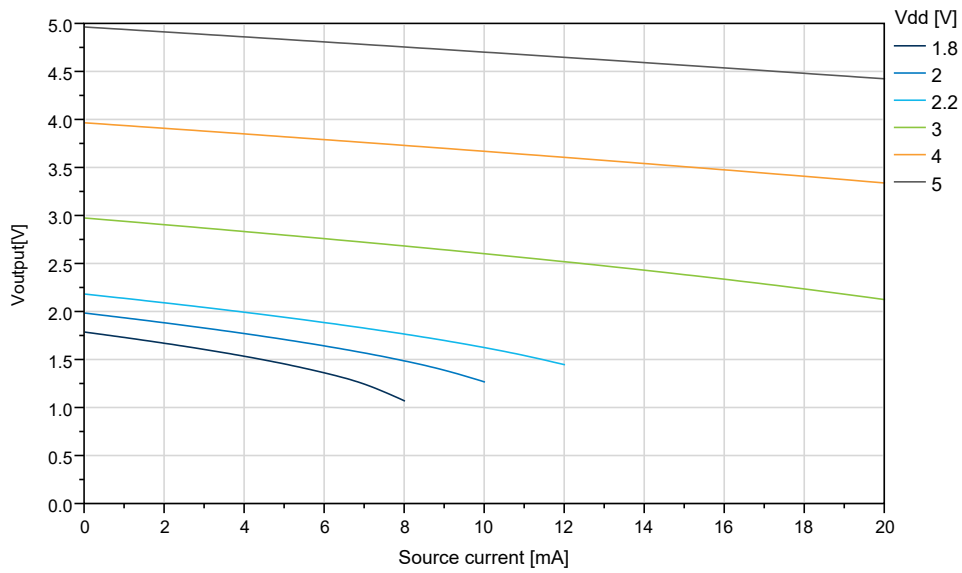


Figure 38-26. I/O Pin Output Voltage vs. Source Current ( $V_{DD}=5.0V$ )

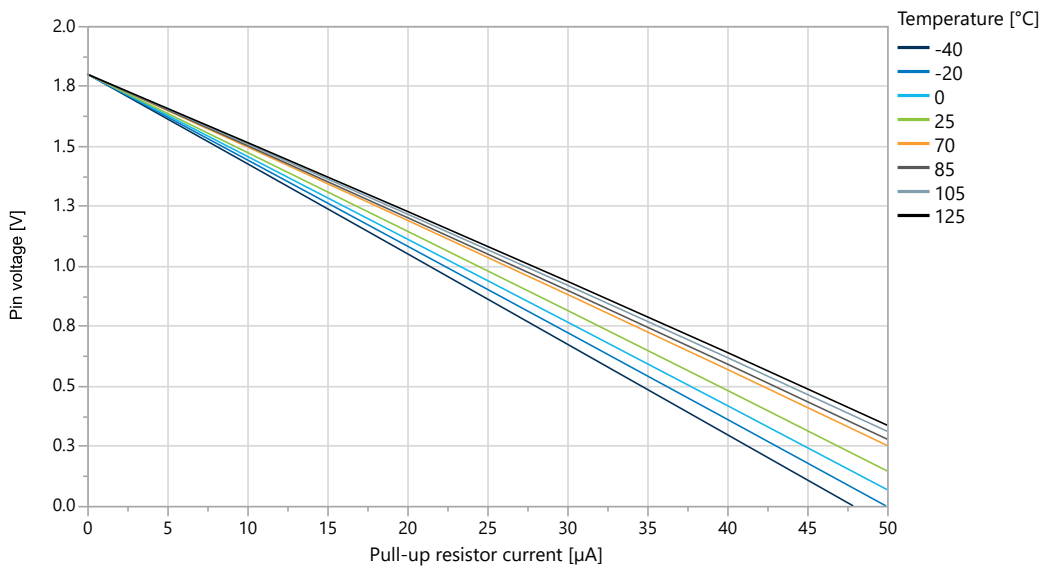


**Figure 38-27. I/O Pin Output Voltage vs. Source Current (T=25°C)**

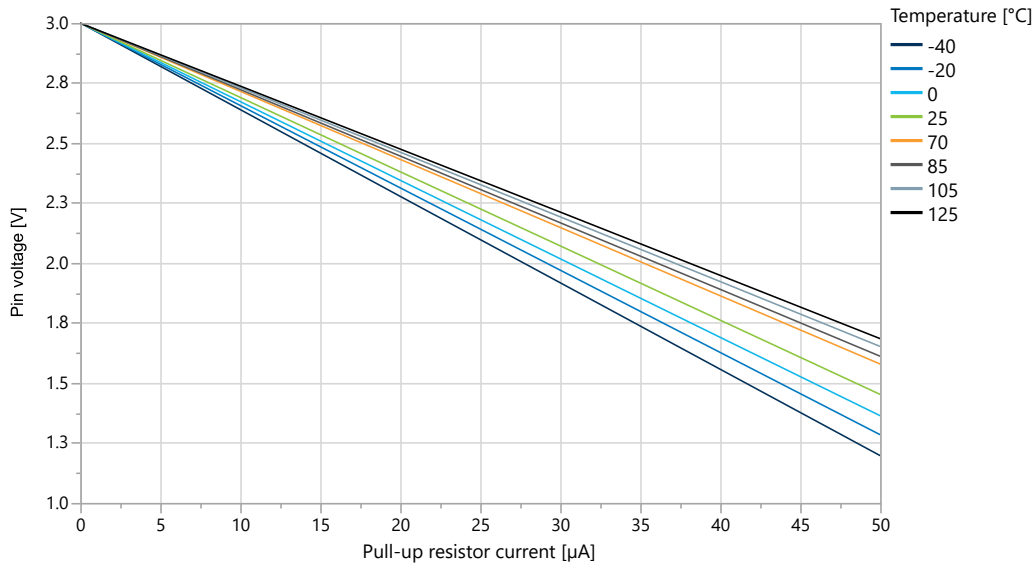


### GPIO Pull-Up Characteristics

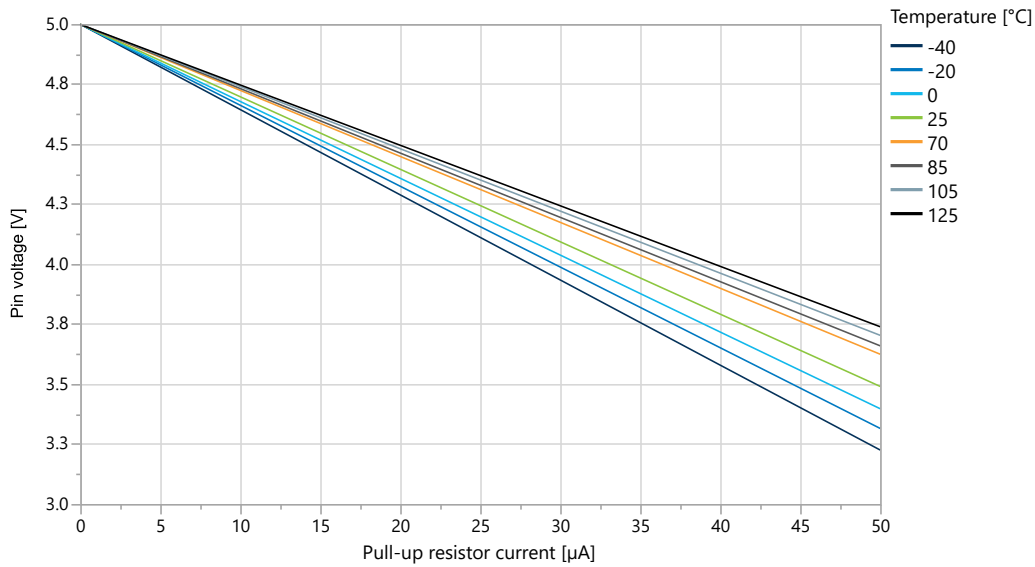
**Figure 38-28. I/O Pin Pull-Up Resistor Current vs. Input Voltage (V<sub>DD</sub>=1.8V)**



**Figure 38-29. I/O Pin Pull-Up Resistor Current vs. Input Voltage ( $V_{DD}=3.0V$ )**

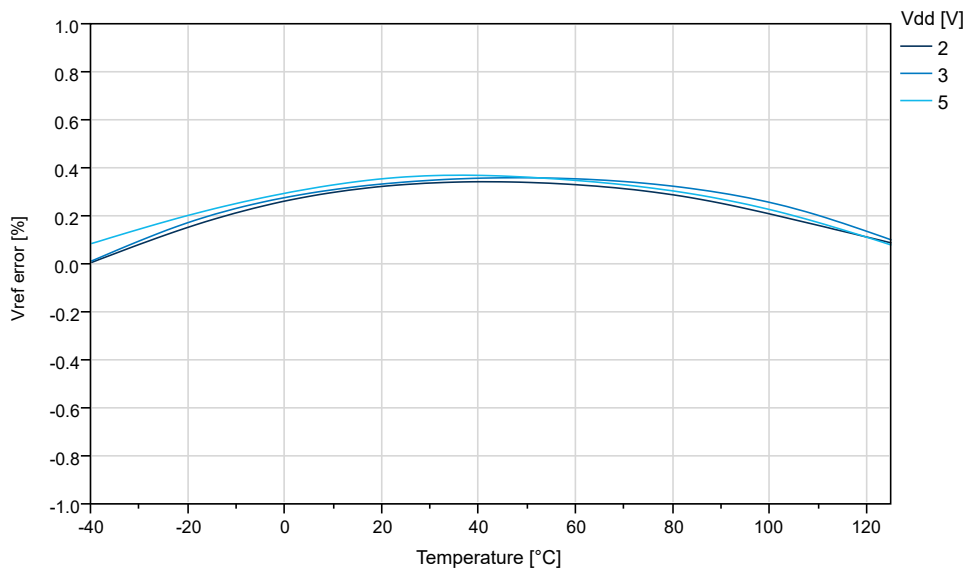


**Figure 38-30. I/O Pin Pull-Up Resistor Current vs. Input Voltage ( $V_{DD}=5.0V$ )**

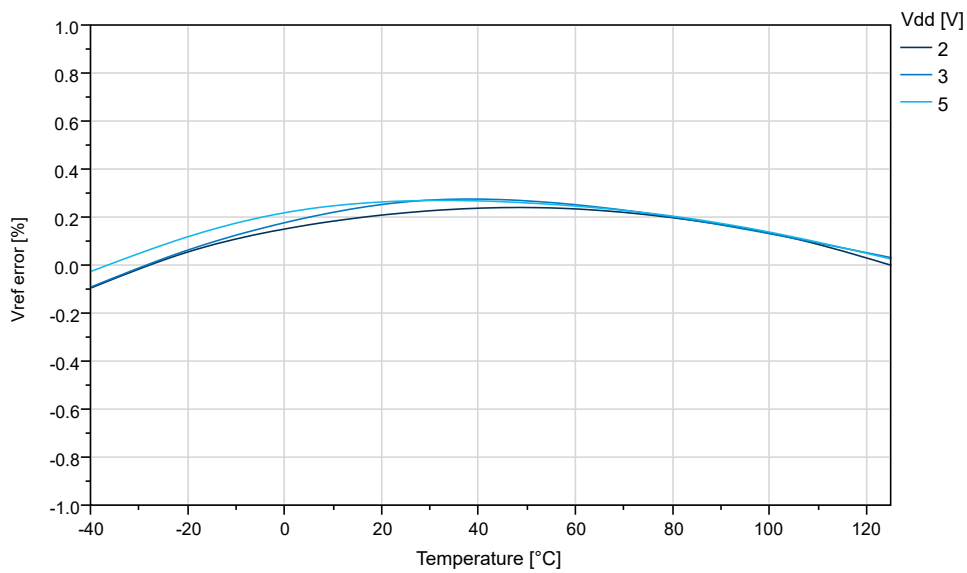


### 38.3 VREF Characteristics

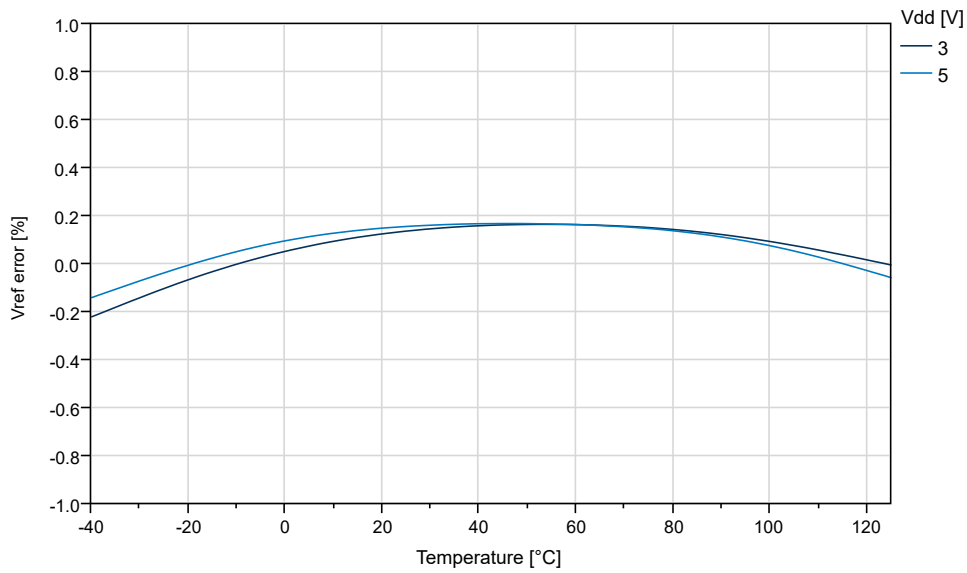
**Figure 38-31. Internal 0.55V Reference vs. Temperature**



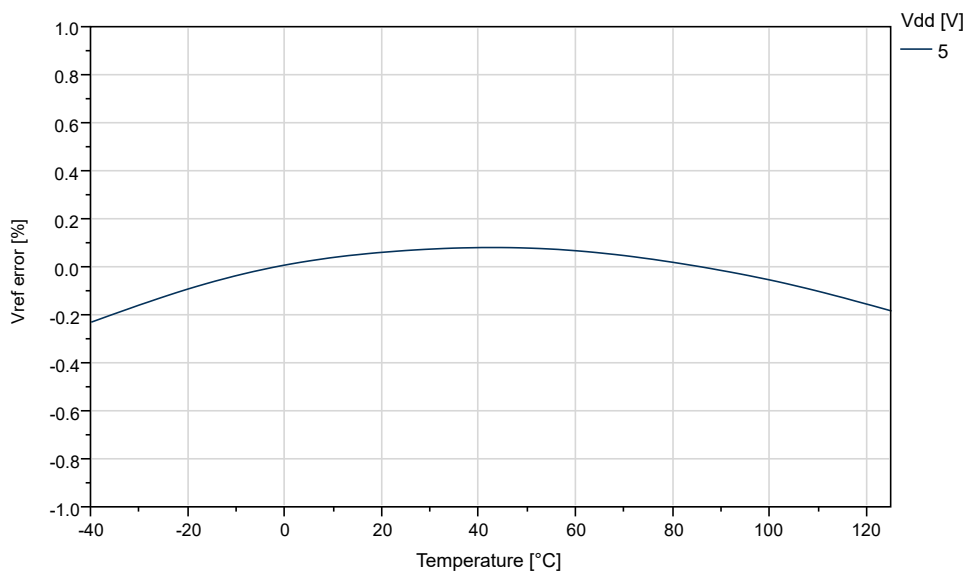
**Figure 38-32. Internal 1.1V Reference vs. Temperature**



**Figure 38-33. Internal 2.5V Reference vs. Temperature**



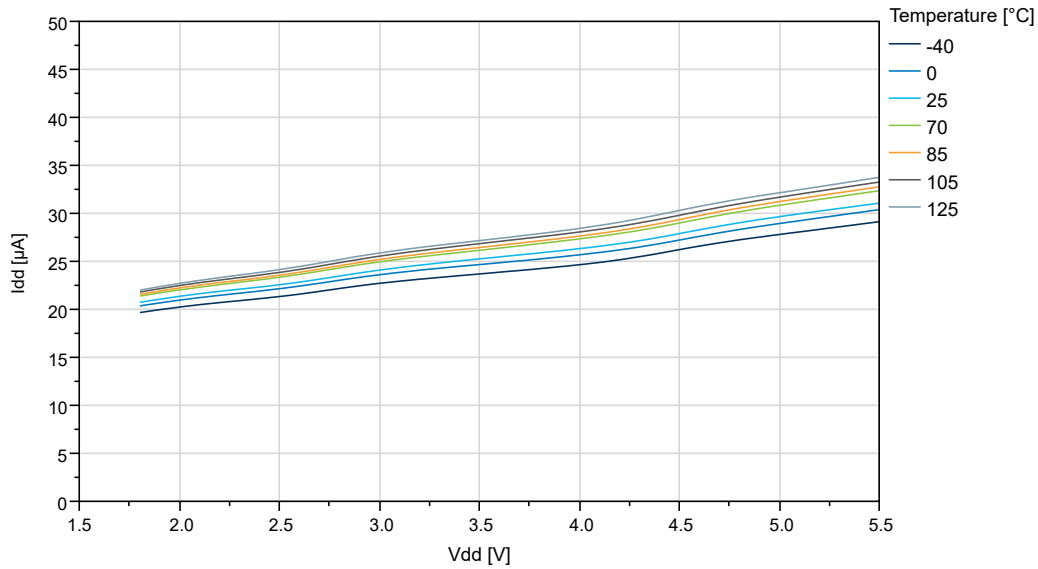
**Figure 38-34. Internal 4.3V Reference vs. Temperature**



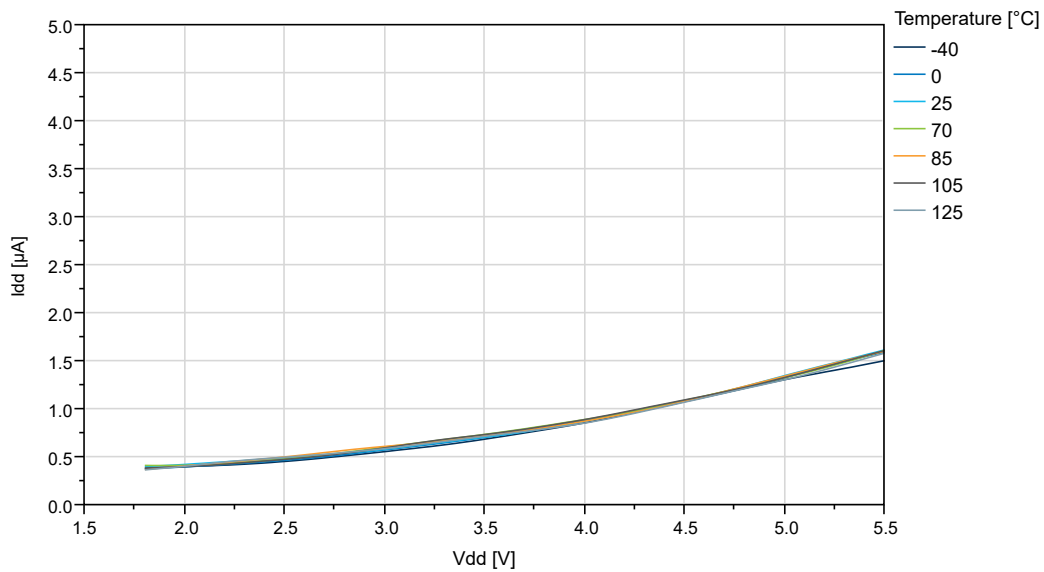
**38.4 BOD Characteristics**

**BOD Current vs.  $V_{DD}$**

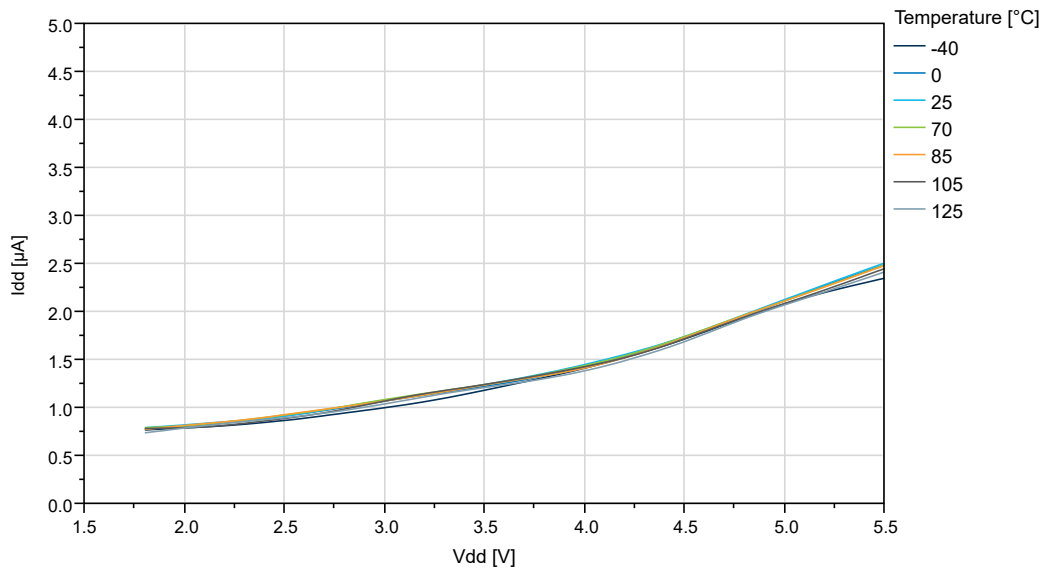
**Figure 38-35. BOD Current vs.  $V_{DD}$  (Continuous Mode Enabled)**



**Figure 38-36. BOD Current vs.  $V_{DD}$  (Sampled BOD at 125 Hz)**

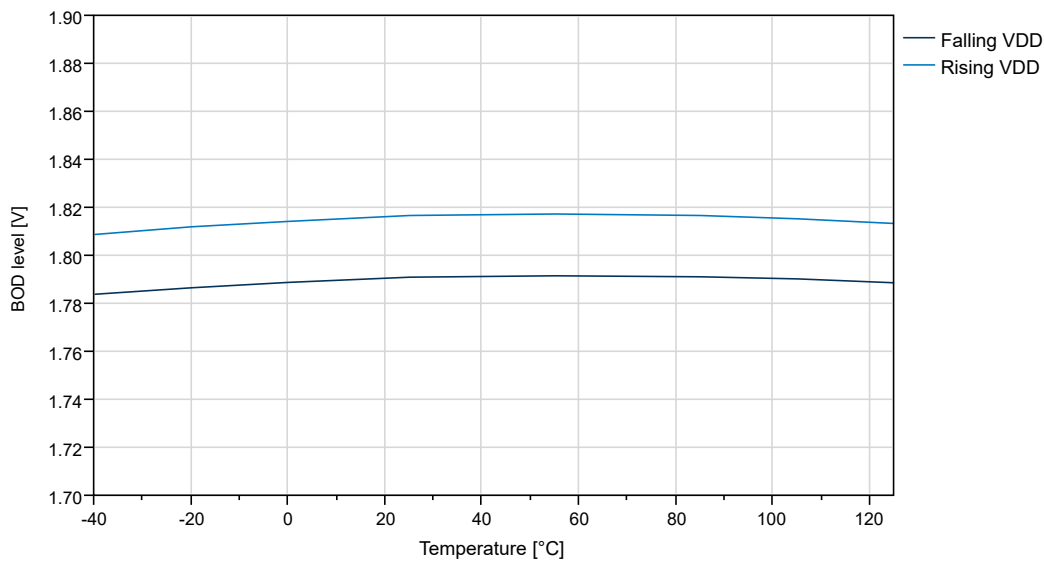


**Figure 38-37. BOD Current vs. V<sub>DD</sub> (Sampled BOD at 1 kHz)**

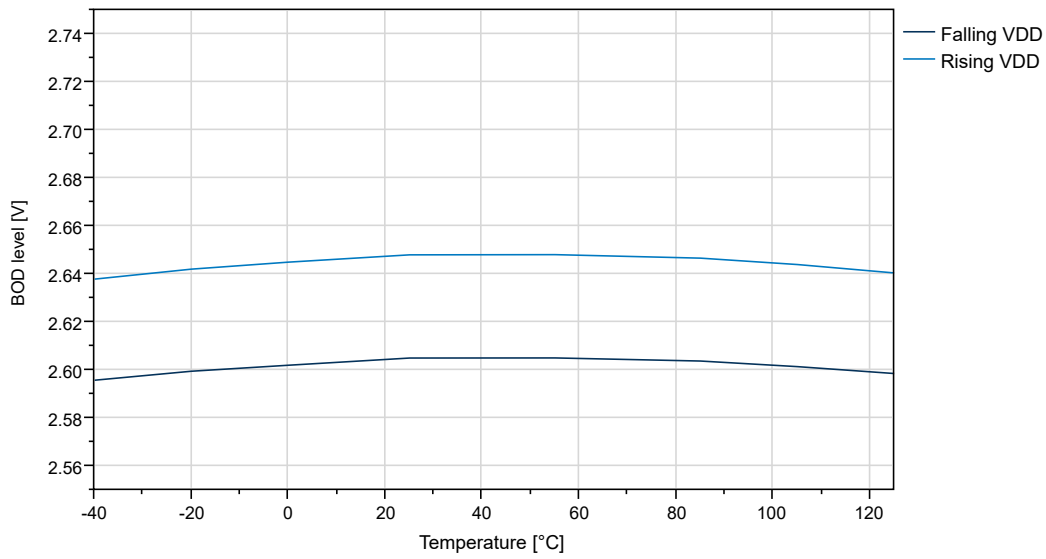


### BOD Threshold vs. Temperature

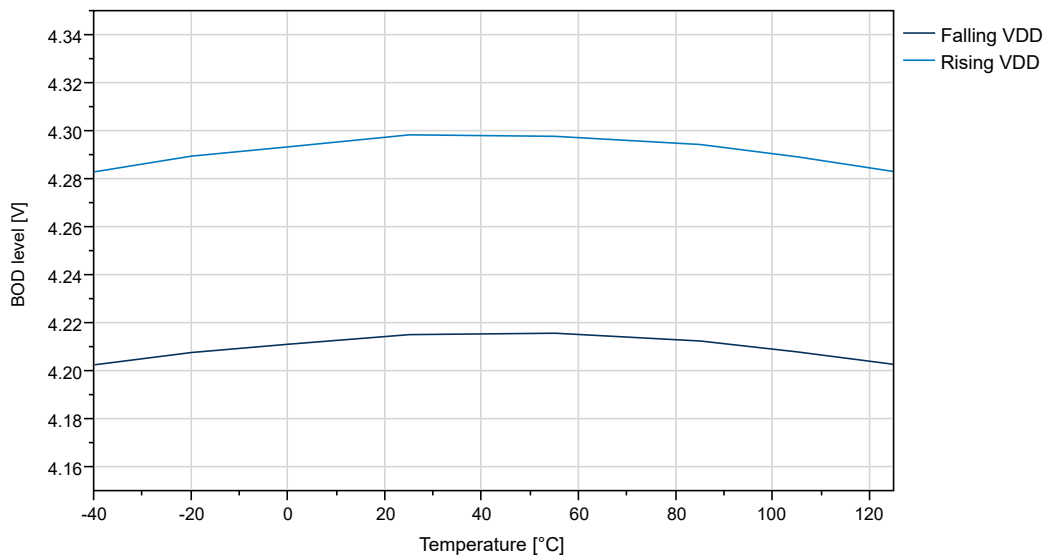
**Figure 38-38. BOD Threshold vs. Temperature (Level 1.8V)**



**Figure 38-39. BOD Threshold vs. Temperature (Level 2.6V)**



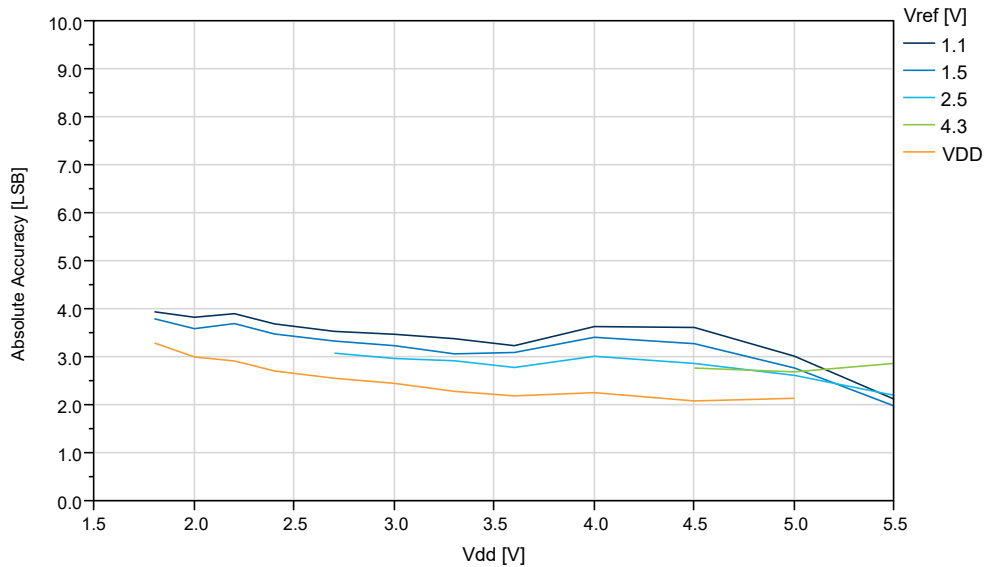
**Figure 38-40. BOD Threshold vs. Temperature (Level 4.3V)**



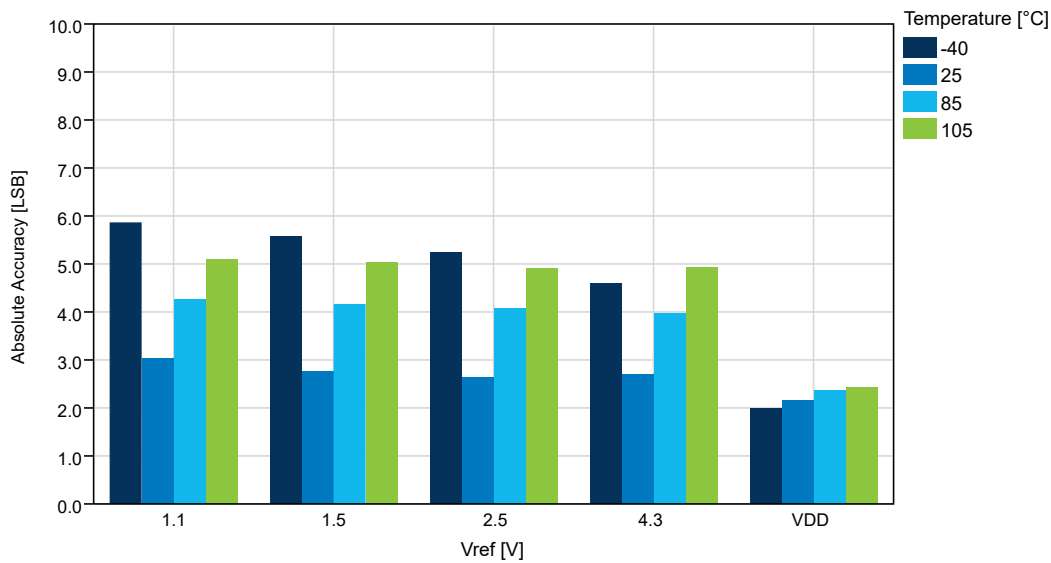


### 38.5 ADC Characteristics

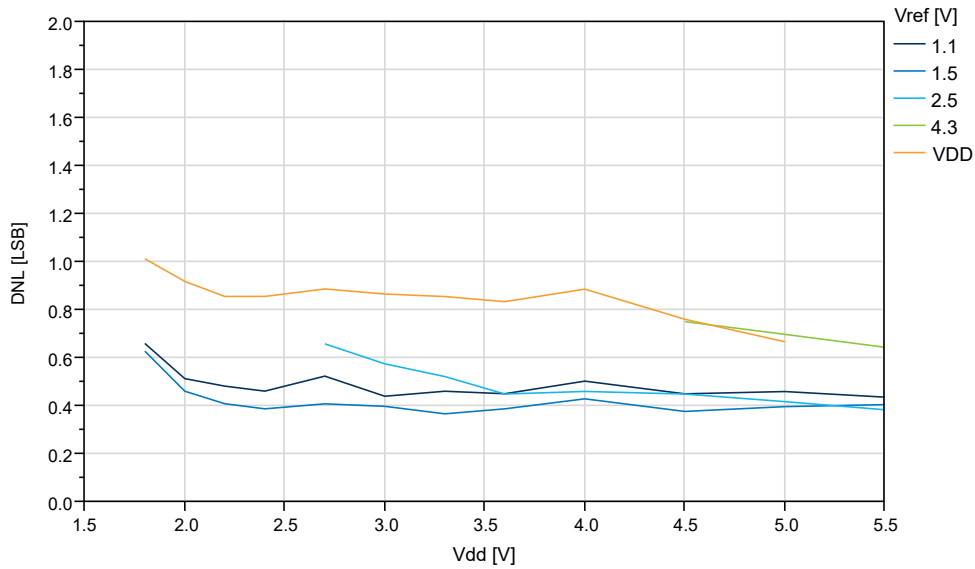
**Figure 38-41. Absolute Accuracy vs.  $V_{DD}$  ( $f_{ADC}=115$  ksp/s) at  $T=25^{\circ}\text{C}$ , REFSEL = Internal Reference**



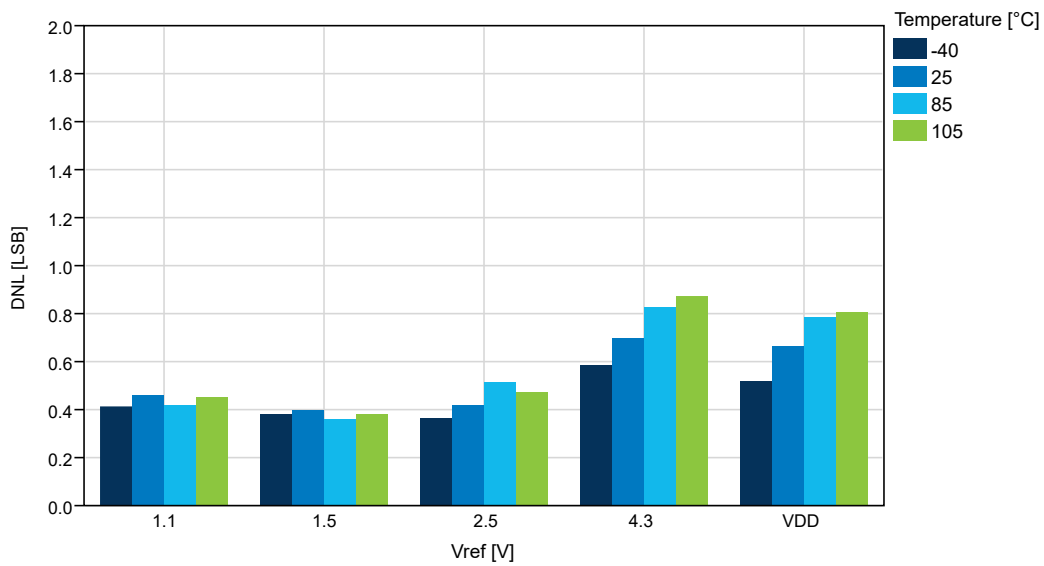
**Figure 38-42. Absolute Accuracy vs.  $V_{ref}$  ( $V_{DD}=5.0\text{V}$ ,  $f_{ADC}=115$  ksp/s), REFSEL = Internal Reference**



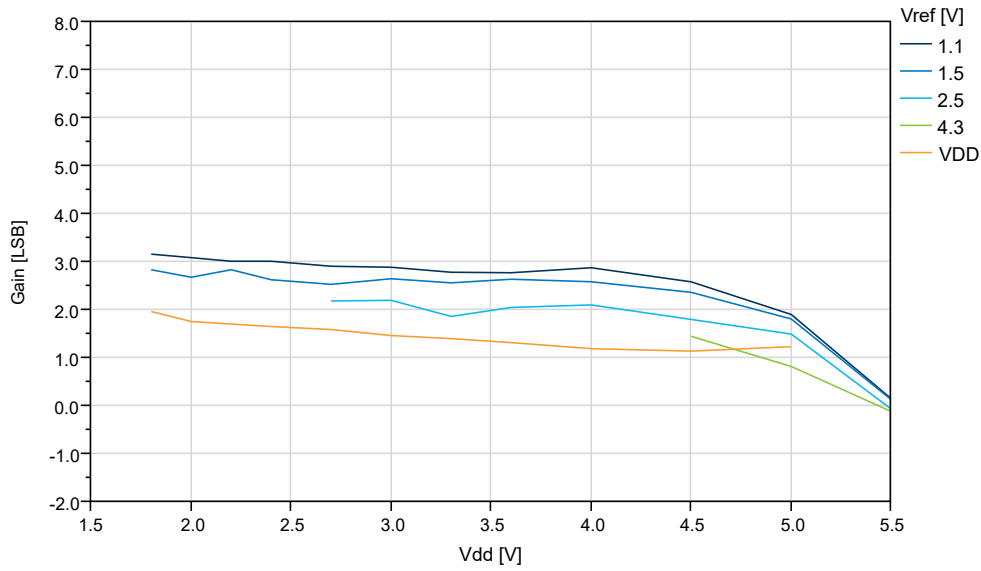
**Figure 38-43. DNL Error vs.  $V_{DD}$  ( $f_{ADC}=115$  ksp/s) at  $T=25^{\circ}\text{C}$ , REFSEL = Internal Reference**



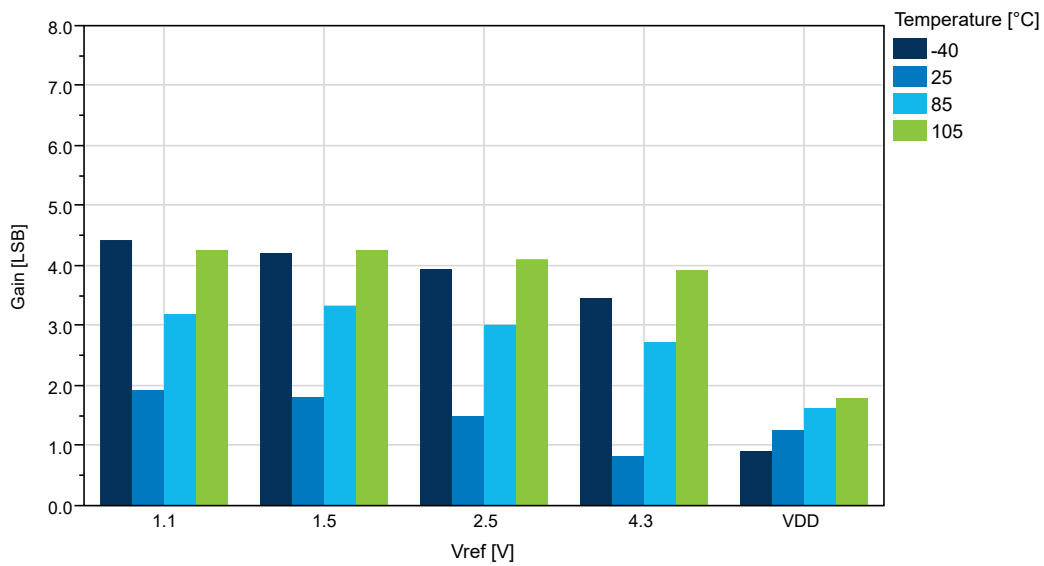
**Figure 38-44. DNL vs.  $V_{ref}$  ( $V_{DD}=5.0\text{V}$ ,  $f_{ADC}=115$  ksp/s), REFSEL = Internal Reference**



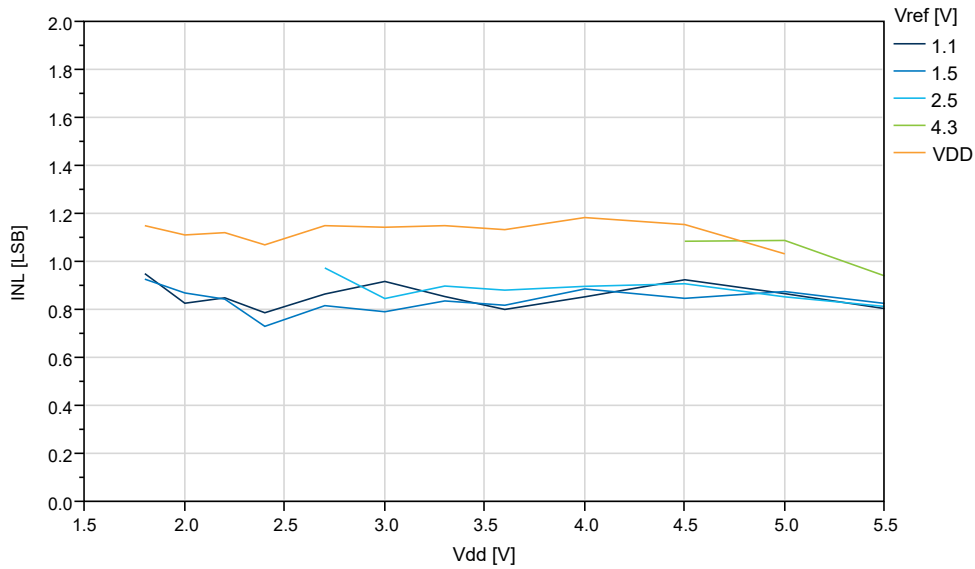
**Figure 38-45. Gain Error vs.  $V_{DD}$  ( $f_{ADC}=115$  ksp/s) at  $T=25^{\circ}\text{C}$ , REFSEL = Internal Reference**



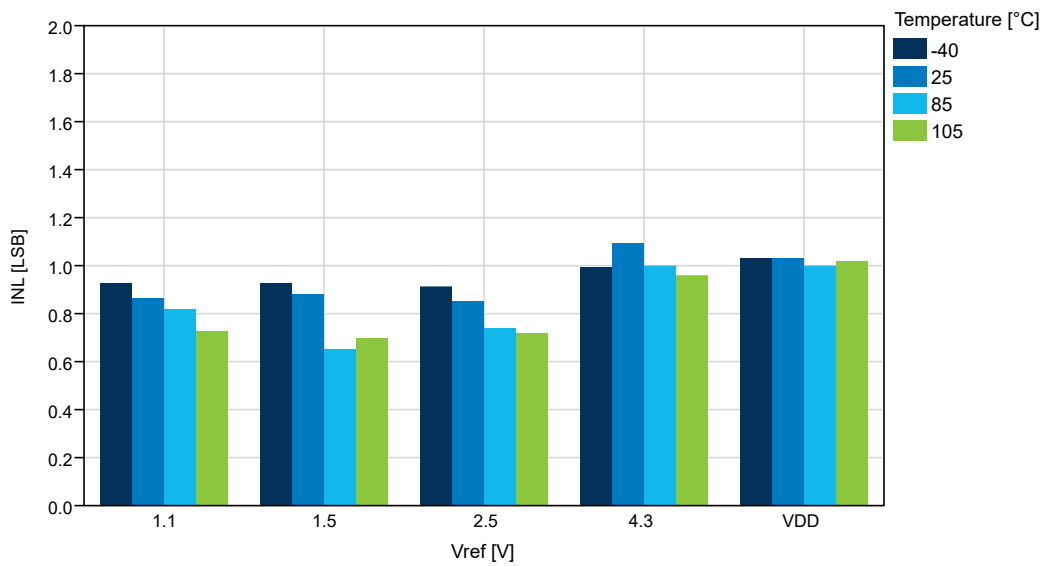
**Figure 38-46. Gain Error vs.  $V_{ref}$  ( $V_{DD}=5.0\text{V}$ ,  $f_{ADC}=115$  ksp/s), REFSEL = Internal Reference**



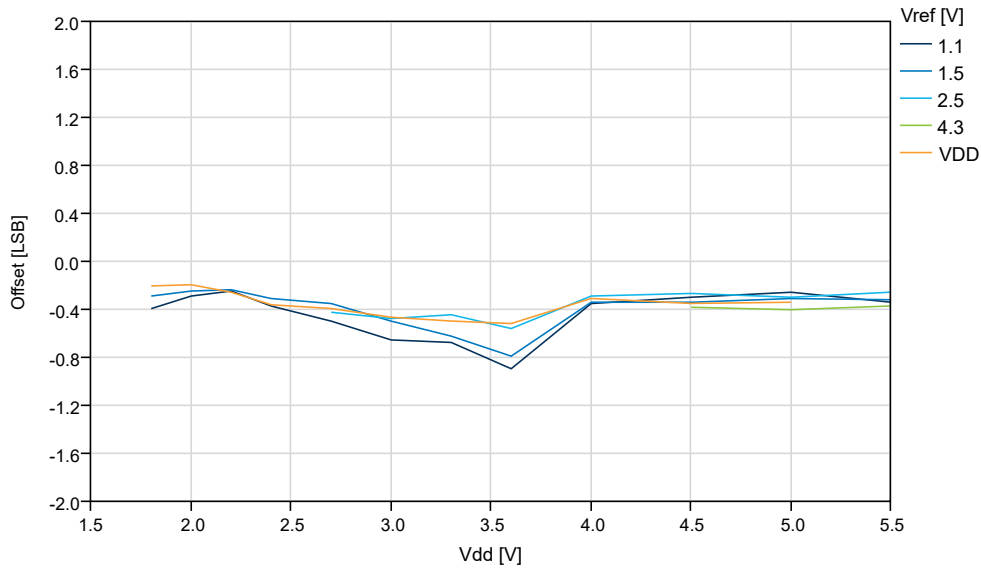
**Figure 38-47. INL vs.  $V_{DD}$  ( $f_{ADC}=115$  kps) at  $T=25^{\circ}\text{C}$ , REFSEL = Internal Reference**



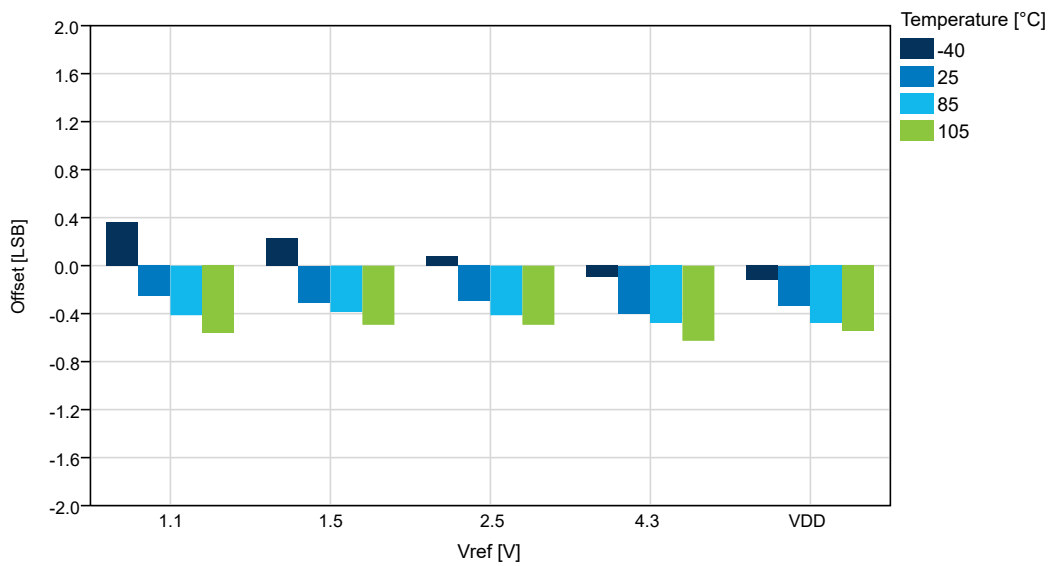
**Figure 38-48. INL vs.  $V_{ref}$  ( $V_{DD}=5.0\text{V}$ ,  $f_{ADC}=115$  kps), REFSEL = Internal Reference**



**Figure 38-49. Offset Error vs.  $V_{DD}$  ( $f_{ADC}=115$  kps) at  $T=25^{\circ}\text{C}$ , REFSEL = Internal Reference**



**Figure 38-50. Offset Error vs.  $V_{ref}$  ( $V_{DD}=5.0\text{V}$ ,  $f_{ADC}=115$  kps), REFSEL = Internal Reference**



### 38.6 AC Characteristics

Figure 38-51. Hysteresis vs.  $V_{CM}$  - 10 mV ( $V_{DD}=5V$ )

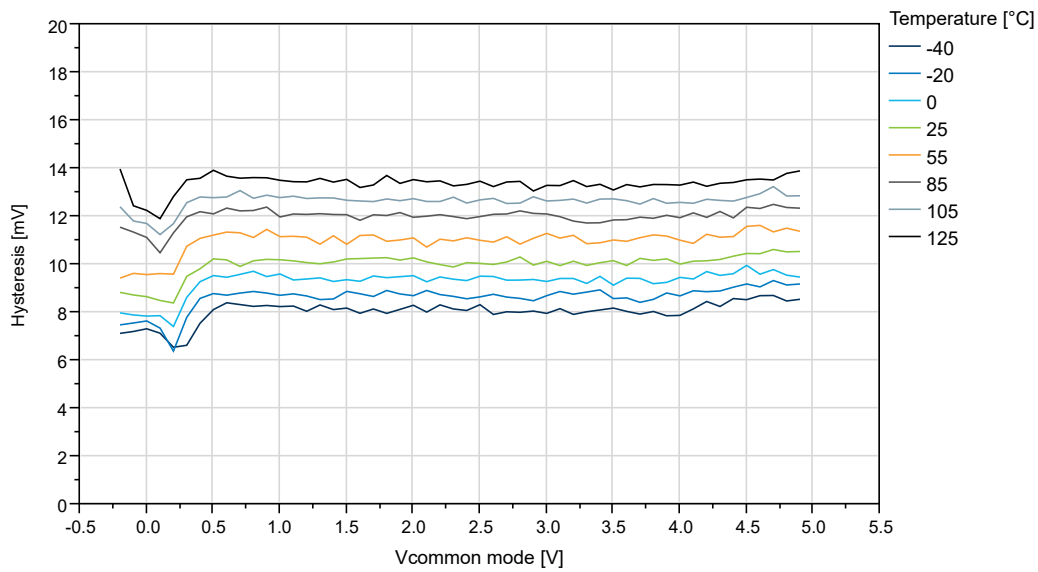
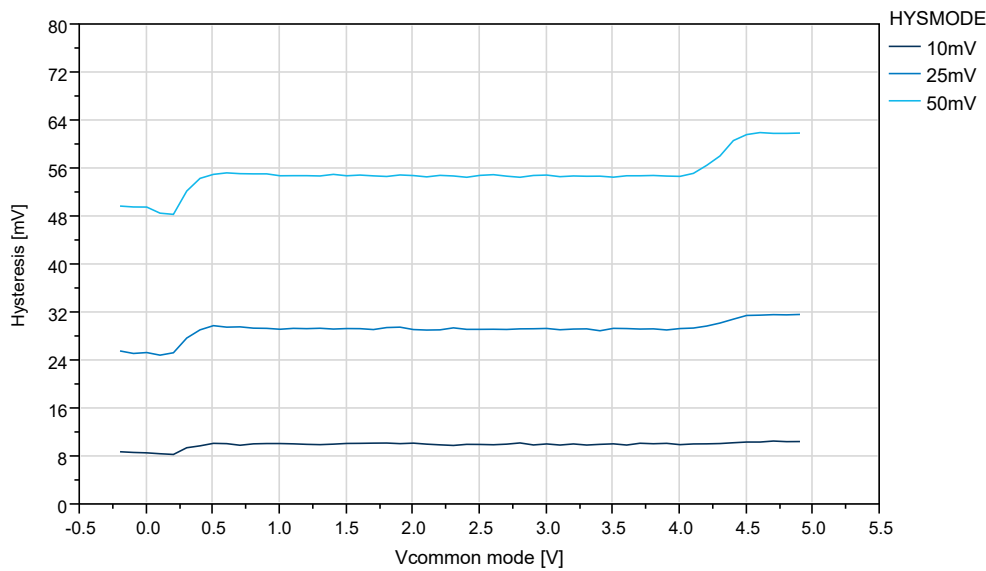
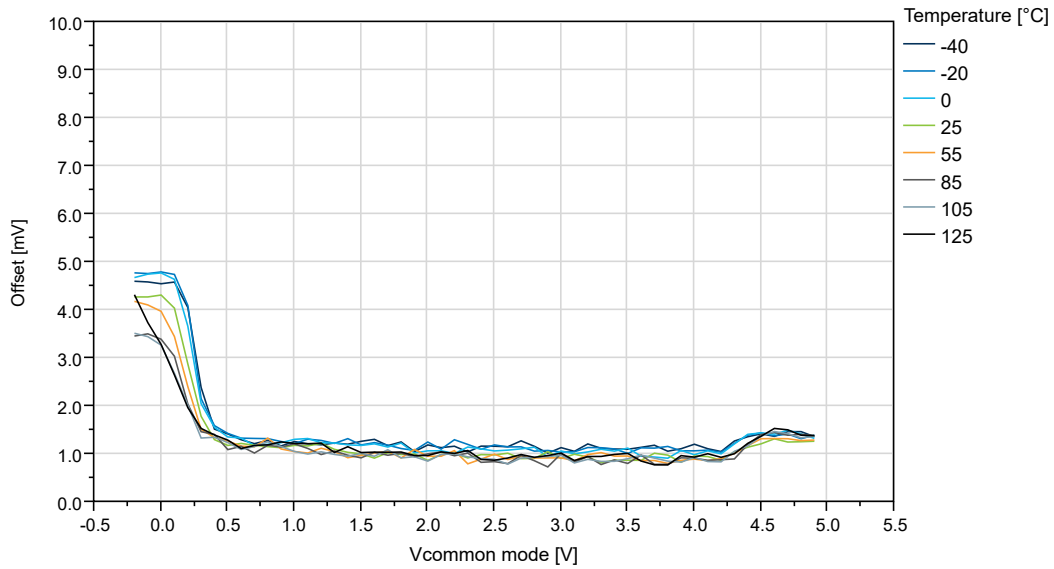


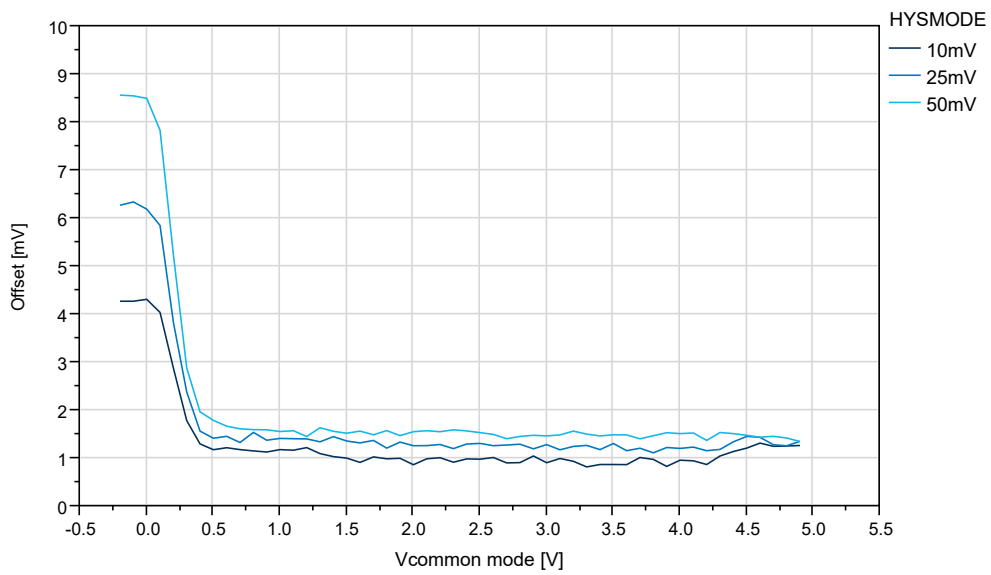
Figure 38-52. Hysteresis vs.  $V_{CM}$  - 10 mV to 50 mV ( $V_{DD}=5V$ ,  $T=25^{\circ}C$ )



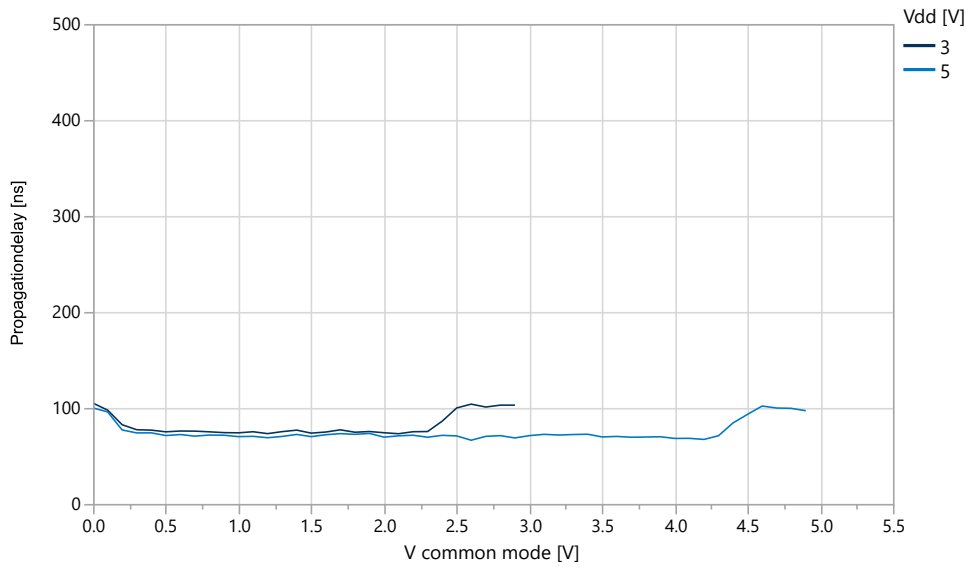
**Figure 38-53. Offset vs.  $V_{CM}$  - 10 mV ( $V_{DD}=5V$ )**



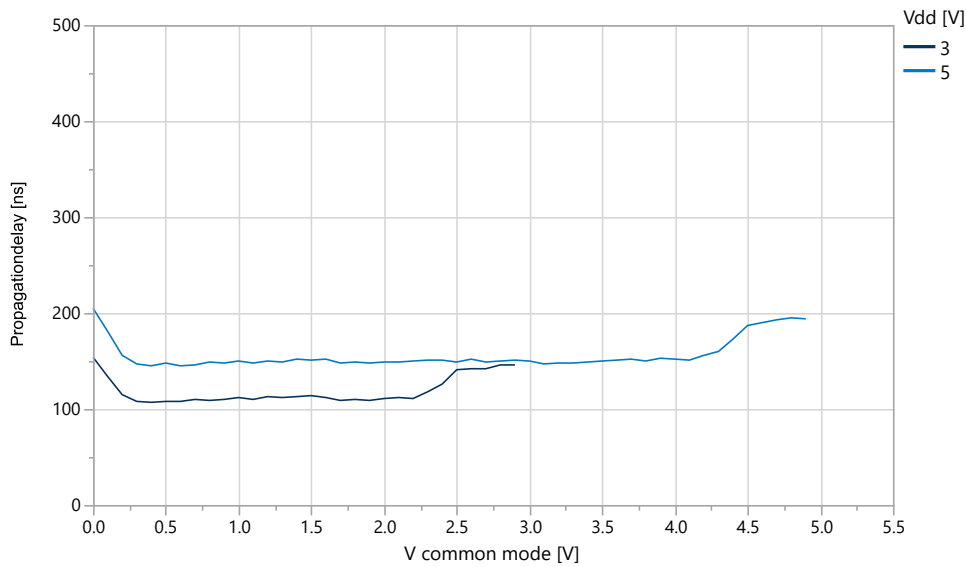
**Figure 38-54. Offset vs.  $V_{CM}$  - 10 mV to 50 mV ( $V_{DD}=5V$ ,  $T=25^{\circ}C$ )**



**Figure 38-55. Propagation Delay vs.  $V_{CM}$  LPMODE Enabled, Falling Positive Input,  $V_{OD} = 25$  mV ( $T=25^{\circ}\text{C}$ )**

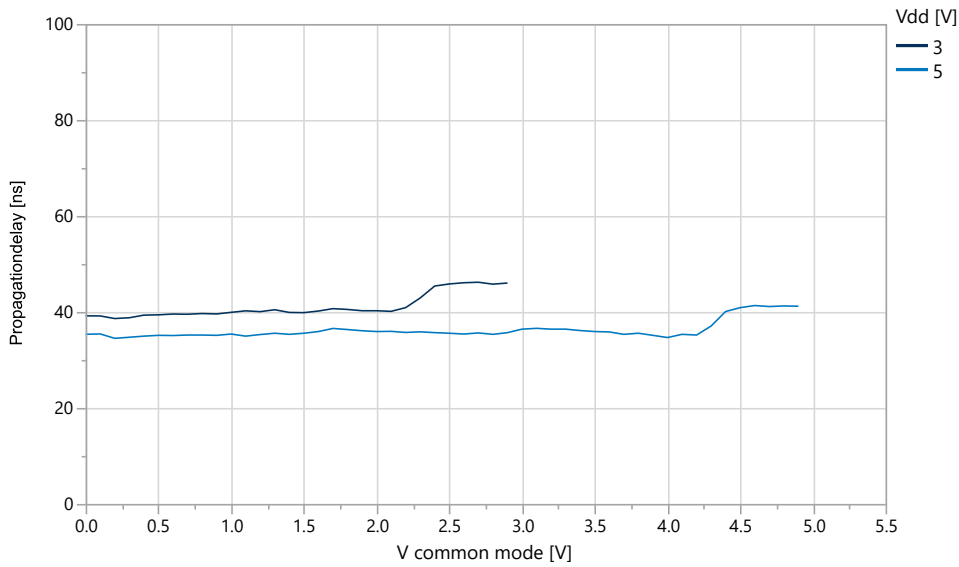


**Figure 38-56. Propagation Delay vs.  $V_{CM}$  LPMODE Enabled, Rising Positive Input,  $V_{OD} = 30$  mV ( $T=25^{\circ}\text{C}$ )**

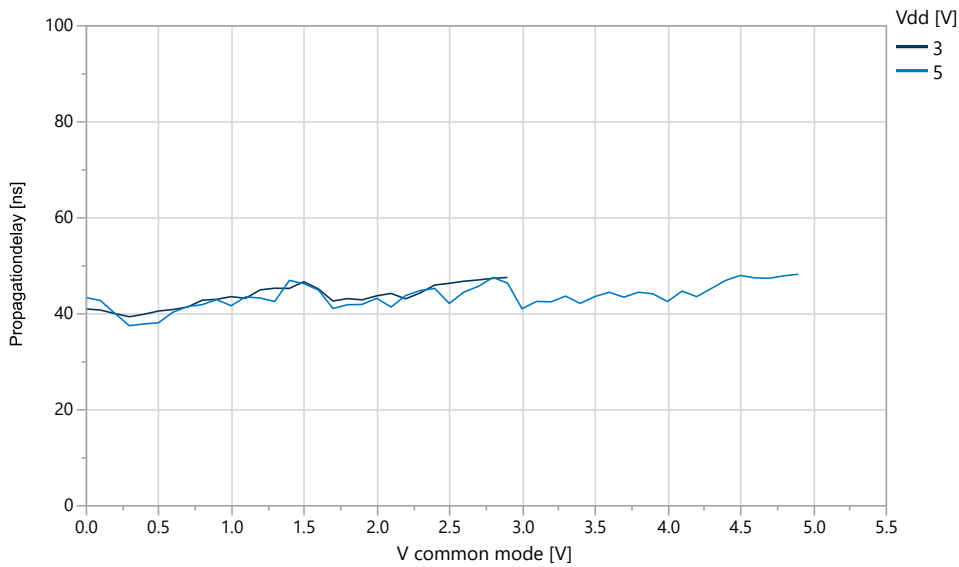




**Figure 38-57. Propagation Delay vs.  $V_{CM}$  LPMODE Disabled, Falling Positive Input,  $V_{OD} = 30\text{ mV}$  ( $T=25^\circ\text{C}$ )**

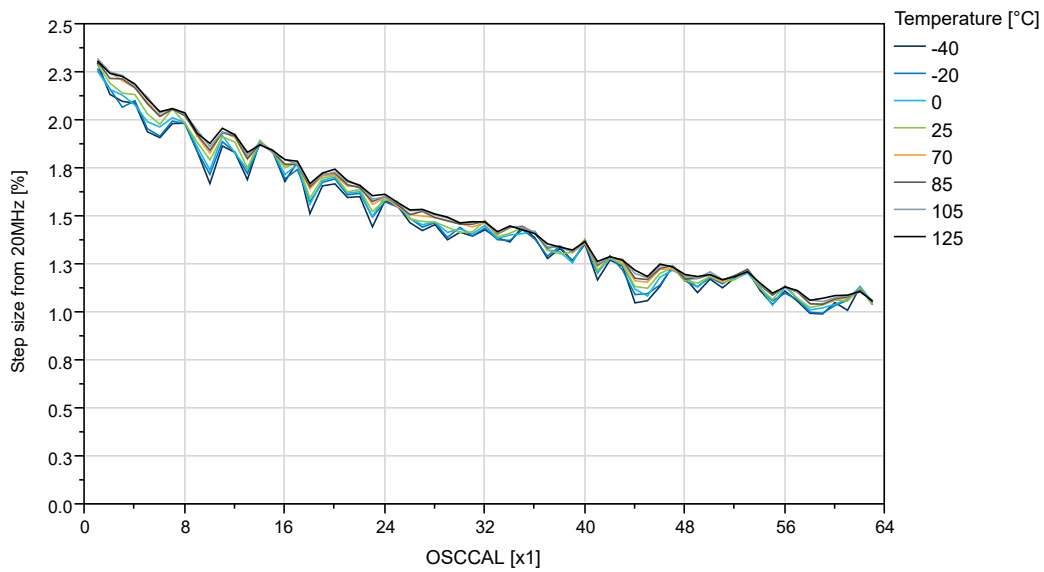


**Figure 38-58. Propagation Delay vs.  $V_{CM}$  LPMODE Disabled, Rising Positive Input,  $V_{OD} = 30\text{ mV}$  ( $T=25^\circ\text{C}$ )**

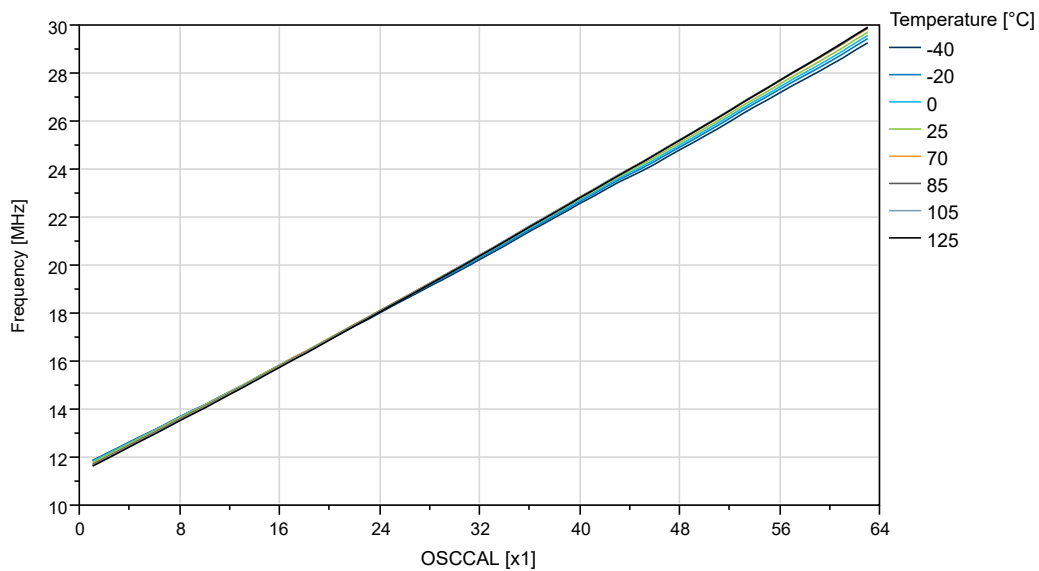


### 38.7 OSC20M Characteristics

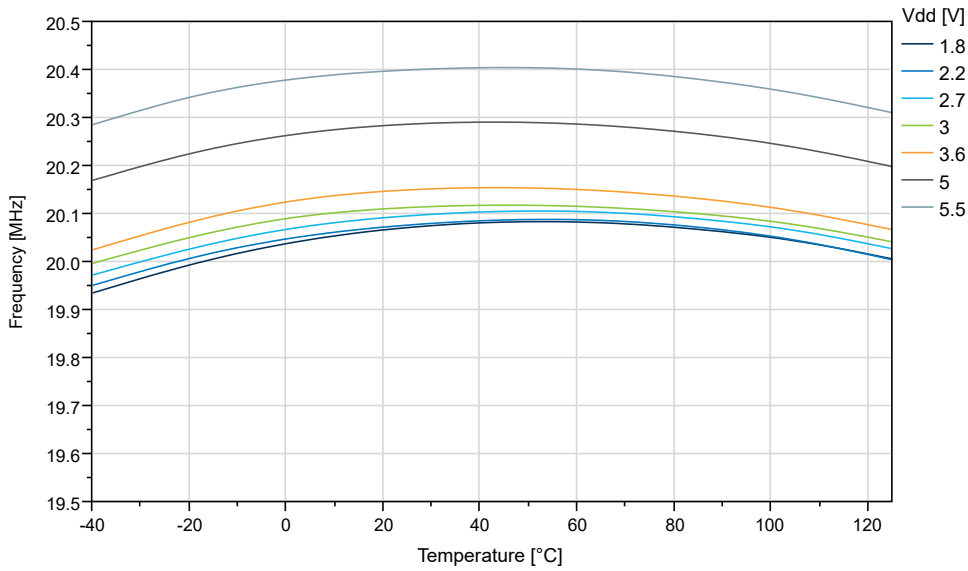
**Figure 38-59. OSC20M Internal Oscillator: Calibration Stepsize vs. Calibration Value ( $V_{DD}=3V$ )**



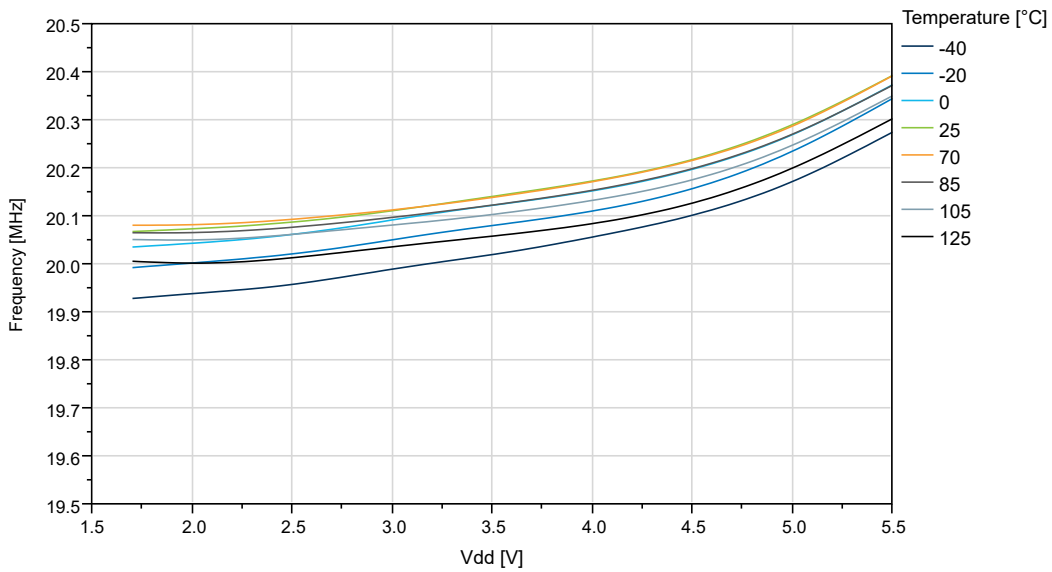
**Figure 38-60. OSC20M Internal Oscillator: Frequency vs. Calibration Value ( $V_{DD}=3V$ )**



**Figure 38-61. OSC20M Internal Oscillator: Frequency vs. Temperature**

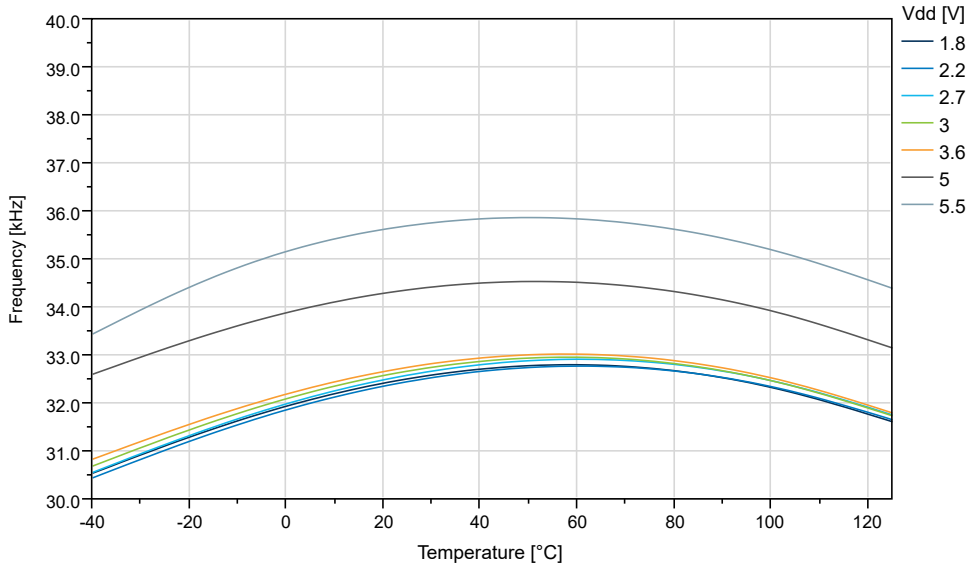


**Figure 38-62. OSC20M Internal Oscillator: Frequency vs. V<sub>DD</sub>**

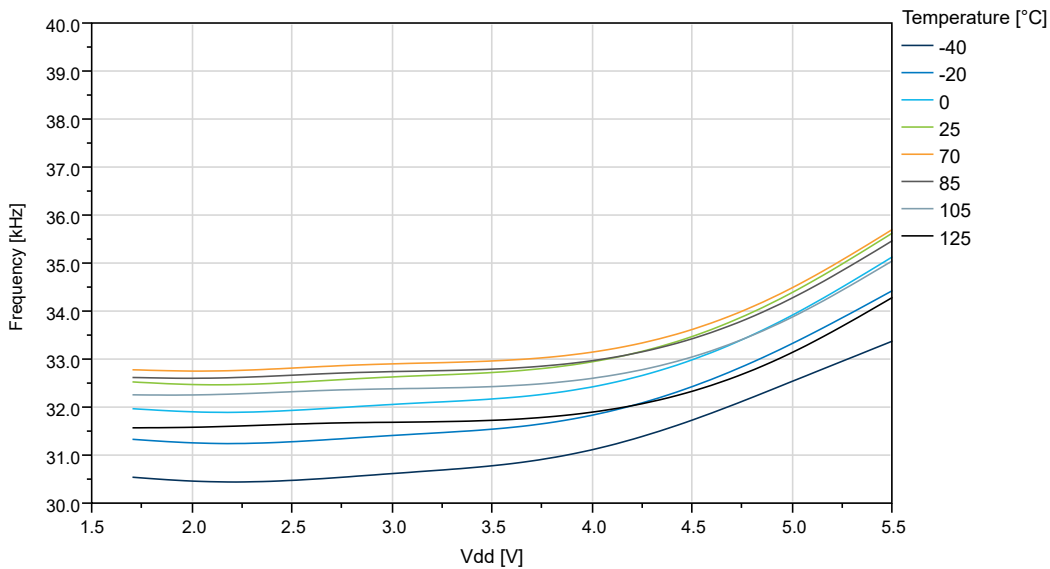


### 38.8 OSCULP32K Characteristics

**Figure 38-63. OSCULP32K Internal Oscillator Frequency vs. Temperature**



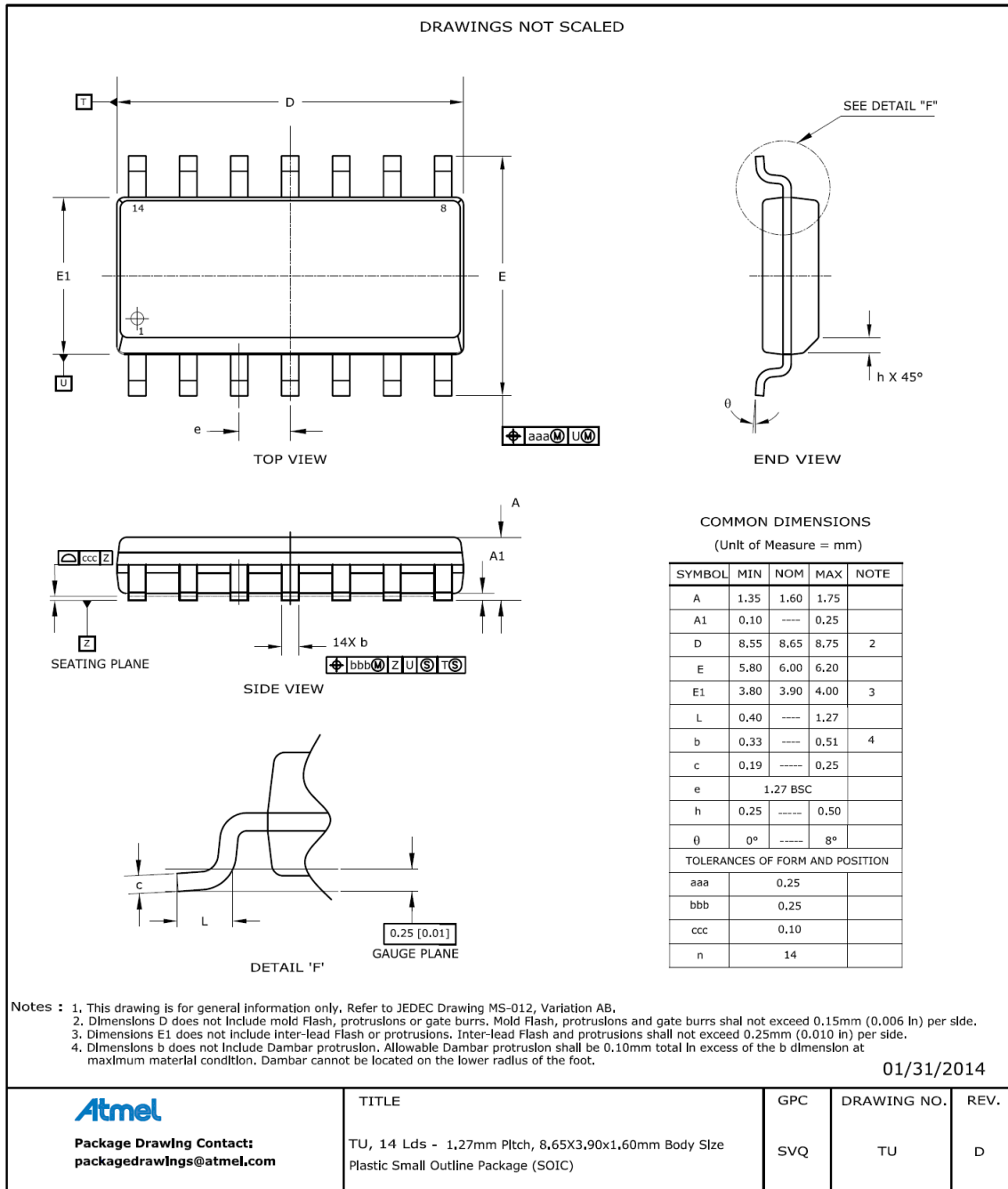
**Figure 38-64. OSCULP32K Internal Oscillator Frequency vs. V<sub>DD</sub>**



### 39. Package Drawings

#### 39.1 14-Pin SOIC150

For the most current package drawings, see the Microchip Packaging Specification located at <http://www.microchip.com/packaging>.



## 39.2 Thermal Considerations

### 39.2.1 Thermal Resistance Data

The following table summarizes the thermal resistance data depending on the package.

**Table 39-1. Thermal Resistance Data**

Package Type	$\theta_{JA}$ [°C/W]	$\theta_{JC}$ [°C/W]
14-pin SOIC150 (SVQ)	58	26

#### Related Links

[39.2.2 Junction Temperature](#)

### 39.2.2 Junction Temperature

The average chip-junction temperature,  $T_J$ , in °C can be obtained from the following:

1.  $T_J = T_A + (P_D \times \theta_{JA})$
2.  $T_J = T_A + (P_D \times (\theta_{HEATSINK} + \theta_{JC}))$

where:

- $\theta_{JA}$  = Package thermal resistance, Junction-to-ambient (°C/W), see Thermal Resistance Data
- $\theta_{JC}$  = Package thermal resistance, Junction-to-case thermal resistance (°C/W), see Thermal Resistance Data
- $\theta_{HEATSINK}$  = Thermal resistance (°C/W) specification of the external cooling device
- $P_D$  = Device power consumption (W)
- $T_A$  = Ambient temperature (°C)

From the first equation, the user can derive the estimated lifetime of the chip and decide if a cooling device is necessary or not. If a cooling device has to be fitted on the chip, the second equation should be used to compute the resulting average chip-junction temperature  $T_J$  in °C.

#### Related Links

[39.2.1 Thermal Resistance Data](#)

---

---

## 40. Errata

### 40.1 ATtiny1614 Errata

#### 40.1.1 Die Revision A

##### 40.1.1.1 AC

1 –

**False triggering when sweeping negative input of the AC when the Low-Power mode is disabled**

A false trigger may occur if sweeping the negative input of the AC with a negative slope and the AC has Low-Power mode disabled.

**Fix/Workaround:**

Enable Low-Power mode in AC.CTRLA.LPMODE

2 –

**AC interrupt flag not set unless interrupt is enabled**

ACn.STATUS.CMP is not set if the ACn.INTCTRL.CMP is not set.

**Fix/Workaround:**

Enable ACn.INTCTRL.CMP or use ACn.STATUS.STATE for polling.

3 –

**False triggers may occur under certain conditions.**

False triggers may occur on falling input pin: - If slew rate on input signal is greater than 2V/us for Common mode voltage below 0.5V - If slew rate on input signal is greater than 10V/us for Common mode voltage above 0.5V - If slew rate on input signal is greater than 10V/us for any Common mode voltage and low power mode is enabled

**Fix/Workaround:**

None.

##### 40.1.1.2 ADC

1 –

**SAMPDLY and ASDV does not work together with SAMPLEN**

Using SAMPCTRL.SAMPLEN at the same time as CTRLD.SAMPDLY or CTRLD.ASDV will cause an unpredictable sampling length.

**Fix/Workaround:**

When setting SAMPCTRL.SAMPLEN greater than zero the CTRLD.SAMPDLY and CTRLD.ASDV must be cleared.

2 –

**ADC interrupt flag cleared when reading RESH**

ADCn.INTFLAGS.RESRDY and ADCn.INTFLAGS.WCOMP are cleared when reading ADCn.RESH.

**Fix/Workaround:**

In 8-bit mode, read ADCn.RESH to clear the flag or clear the flag directly.

3 –

**Changing ADC control bits during Free-Running mode not working**

If control signals are changed during Free-Running mode, the new configuration is not properly taken into account in the next measurement. This is valid for registers ADC.CTRLB, ADC.CTRLA, ADC.SAMPCTRL and ADC.MUXPOS, ADC.WINLT and ADC.WINHT.

**Fix/Workaround:**

Disable ADC Free-Running mode before update of ADC.CTRLB, ADC.CTRLA, ADC.SAMPCTRL, ADC.MUXPOS, ADC.WINLT or ADC.WINHT.

**4 –**

**One extra measurement performed after disabling ADC Free-Running mode**

The ADC may perform one additional measurement after clearing ADCn.CTRLA.FREERUN

**Fix/Workaround:**

Write ADCn.CTRLA.ENABLE to zero to stop the Free-Running mode immediately.

**5 –**

**ADC wake-up with WCOMP**

When waking up from STANDBY Sleep mode with ADC WCOMP interrupt the ADC is disabled for a few cycles before the device enters ACTIVE mode. A new INITDLY is required before next conversion.

**Fix/Workaround:**

Use INITDLY before next conversion.

**6 –**

**Pending event stuck when disabling the ADC**

If the ADC is disabled during an event-triggered conversion, the event will not be cleared.

**Fix/Workaround:**

Clear ADC.EVCTRL.STARTEI and wait for conversion to complete before disabling the ADC.

**7 –**

**ADC functionality cannot be ensured with ADCCLK above 1.5MHz for all conditions**

The ADC functionality cannot be ensured if ADCCLK > 1.5 MHz with ADCn.CALIB.DUTYCYC set to 1. The ADC functionality cannot be ensured if ADCCLK > 1.5 MHz and VDD < 2.7V.

**Fix/Workaround:**

If ADC is operated with CLK\_ADC > 1.5 MHz and VDD > 2.7V, ADCn.CALIB.DUTYCYC must be set to zero (50% dutycycle). Do not use ADC at CLK\_ADC > 1.5 MHz and VDD < 2.7V

**40.1.1.3 CCL**

**1 –**

**Connecting LUTs in Linked mode requires OUTEN set to one**

Connecting the LUTs in Linked mode requires LUTnCTRLA.OUTEN set to one for the LUT providing the input source.

**Fix/Workaround:**



Use an event channel to link the LUTs or do not use the corresponding I/O pin for other purposes.

2 –

**D-latch is not functional**

The CCL D-latch is not functional.

**Fix/Workaround:**

None.

### 40.1.1.4 RTC

1 –

**Any write to the RTC.CTRLA register resets the RTC and PIT prescaler**

Any write to the RTC.CTRLA register resets the RTC and PIT prescaler

**Fix/Workaround:**

None.

2 –

**Disabling RTC will also stop the PIT**

Writing RTC.CTRLA.RTCEN to zero will also stop the PIT and writing RTC.PITCTRLA.PITEN to zero will also stop the RTC.

**Fix/Workaround:**

Do not disable the RTC or the PIT if any of the modules are used.

### 40.1.1.5 TCB

1 –

**TCB interrupt flag cleared when reading CCMPH**

TCBn.INTFLAGS.CAPT is cleared when reading TCBn.CCMPH instead of CCMPL.

**Fix/Workaround:**

Read both TCBn.CCMPL and TCBn.CCMPH.

2 –

**TCB input capture frequency and Pulse-Width Measurement mode not working with prescaled clock**

The TCB input capture frequency and Pulse-Width Measurement mode may lock to freeze state if CLKSEL in TCB.CTRLA is set to other value than 0x0.

**Fix/Workaround:**

Only use CLKSEL equal to 0x0 when using Input capture frequency and Pulse-Width Measurement mode.

3 –

**TCA restart command does not force a restart of TCB**

The TCA restart command does not force a restart of the TCB when TCB is running in SYNCUPD mode. TCB is only restarted after a TCA OVF.

**Fix/Workaround:**

None.

### 40.1.1.6 TCD

1 –

**TCD event output lines may give false events**

The TCD event output lines can give out false events.

**Fix/Workaround:**

Use the delayed event functionality with minimum one cycle delay.

2 –

**TCD autoupdate not working**

The TCD autoupdate feature is not working.

**Fix/Workaround:**

None.

### 40.1.1.7 TWI

1 –

**TIMEOUT bits in TWI.MCTRLB register is not accessible**

The TIMEOUT bits in TWI.MCTRLB register is not accessible from software.

**Fix/Workaround:**

When initializing TWI, BUSSTATE in TWI.MSTATUS should be brought into IDLE state by writing 0x1 to it.

2 –

**TWI Master Mode wrongly detect start bit as a stop bit**

If TWI is enabled in Master mode followed by an immediate write to the MADDR register, the bus monitor recognize the Start bit as a Stop bit.

**Fix/Workaround:**

Wait minimum two clock cycles from TWI.MCTRLA.ENABLE until TWI.MADDR is written.

3 –

**TWI Smart mode gives extra clock pulse**

TWI Master with Smart mode enabled gives an extra clock pulse on SCL line after sending NACK.

**Fix/Workaround:**

None.

4 –

**TWI Master Enable Quick Command not accessible**

TWI.MCTRLA.QCEN is not accessible from software.

**Fix/Workaround:**

None.

### 40.1.1.8 USART

1 –

**Frame error on previous message may cause false Start bit detection**

If receiving a frame with RXDATAH.FERR set and reading the RXDATAL before the RxD line goes high, will trigger a false Start bit detection.

**Fix/Workaround:**

Wait for the RxD pin to go high before reading RXDATA, for instance by polling the bit in PORTn.IN where the RxD pin is located.

## 41. Data Sheet Revision History

**Note:** The data sheet revision is independent of the die revision and the device variant (last letter of the ordering number).

### 41.1 Rev. A - 06/2018

Section	Changes
Document	Initial Release

**Note:**

The ATtiny1614 device was previously described in Microchip document 40001893 rev. C (common data sheet for ATtiny1617/1616/1614 devices).

With the introduction of the ATtiny3216 and ATtiny3217 devices, 40001893 rev. C was replaced by three new data sheets:

- ATtiny1617 and ATtiny3217
- ATtiny1616 and ATtiny3216
- ATtiny1614 (this document)

## The Microchip Web Site

---

Microchip provides online support via our web site at <http://www.microchip.com/>. This web site is used as a means to make files and information easily available to customers. Accessible by using your favorite Internet browser, the web site contains the following information:

- **Product Support** – Data sheets and errata, application notes and sample programs, design resources, user's guides and hardware support documents, latest software releases and archived software
- **General Technical Support** – Frequently Asked Questions (FAQ), technical support requests, online discussion groups, Microchip consultant program member listing
- **Business of Microchip** – Product selector and ordering guides, latest Microchip press releases, listing of seminars and events, listings of Microchip sales offices, distributors and factory representatives

## Customer Change Notification Service

---

Microchip's customer notification service helps keep customers current on Microchip products. Subscribers will receive e-mail notification whenever there are changes, updates, revisions or errata related to a specified product family or development tool of interest.

To register, access the Microchip web site at <http://www.microchip.com/>. Under "Support", click on "Customer Change Notification" and follow the registration instructions.

## Customer Support

---

Users of Microchip products can receive assistance through several channels:

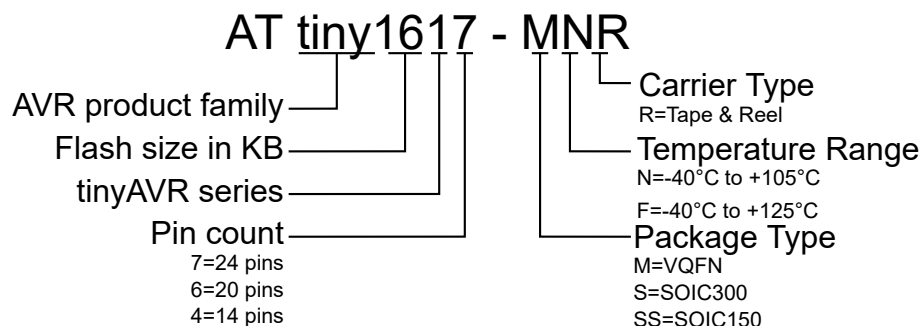
- Distributor or Representative
- Local Sales Office
- Field Application Engineer (FAE)
- Technical Support

Customers should contact their distributor, representative or Field Application Engineer (FAE) for support. Local sales offices are also available to help customers. A listing of sales offices and locations is included in the back of this document.

Technical support is available through the web site at: <http://www.microchip.com/support>

## Product Identification System

To order or obtain information, e.g., on pricing or delivery, refer to the factory or the listed sales office.



## Microchip Devices Code Protection Feature

Note the following details of the code protection feature on Microchip devices:

- Microchip products meet the specification contained in their particular Microchip Data Sheet.
- Microchip believes that its family of products is one of the most secure families of its kind on the market today, when used in the intended manner and under normal conditions.
- There are dishonest and possibly illegal methods used to breach the code protection feature. All of these methods, to our knowledge, require using the Microchip products in a manner outside the operating specifications contained in Microchip's Data Sheets. Most likely, the person doing so is engaged in theft of intellectual property.
- Microchip is willing to work with the customer who is concerned about the integrity of their code.
- Neither Microchip nor any other semiconductor manufacturer can guarantee the security of their code. Code protection does not mean that we are guaranteeing the product as "unbreakable."

Code protection is constantly evolving. We at Microchip are committed to continuously improving the code protection features of our products. Attempts to break Microchip's code protection feature may be a violation of the Digital Millennium Copyright Act. If such acts allow unauthorized access to your software or other copyrighted work, you may have a right to sue for relief under that Act.

## Legal Notice

Information contained in this publication regarding device applications and the like is provided only for your convenience and may be superseded by updates. It is your responsibility to ensure that your application meets with your specifications. MICROCHIP MAKES NO REPRESENTATIONS OR WARRANTIES OF ANY KIND WHETHER EXPRESS OR IMPLIED, WRITTEN OR ORAL, STATUTORY OR OTHERWISE, RELATED TO THE INFORMATION, INCLUDING BUT NOT LIMITED TO ITS CONDITION, QUALITY, PERFORMANCE, MERCHANTABILITY OR FITNESS FOR PURPOSE. Microchip disclaims all liability arising from this information and its use. Use of Microchip devices in life support and/or safety applications is entirely at the buyer's risk, and the buyer agrees to defend, indemnify and hold harmless Microchip from any and all damages, claims, suits, or expenses resulting from such use. No licenses are conveyed, implicitly or otherwise, under any Microchip intellectual property rights unless otherwise stated.

## **Trademarks**

---

The Microchip name and logo, the Microchip logo, AnyRate, AVR, AVR logo, AVR Freaks, BeaconThings, BitCloud, CryptoMemory, CryptoRF, dsPIC, FlashFlex, flexPWR, Heldo, JukeBlox, KeeLoq, KeeLoq logo, Kleer, LANCheck, LINK MD, maXStylus, maXTouch, MediaLB, megaAVR, MOST, MOST logo, MPLAB, OptoLyzer, PIC, picoPower, PICSTART, PIC32 logo, Prochip Designer, QTouch, RightTouch, SAM-BA, SpyNIC, SST, SST Logo, SuperFlash, tinyAVR, UNI/O, and XMEGA are registered trademarks of Microchip Technology Incorporated in the U.S.A. and other countries.

ClockWorks, The Embedded Control Solutions Company, EtherSynch, Hyper Speed Control, HyperLight Load, IntelliMOS, mTouch, Precision Edge, and Quiet-Wire are registered trademarks of Microchip Technology Incorporated in the U.S.A.

Adjacent Key Suppression, AKS, Analog-for-the-Digital Age, Any Capacitor, AnyIn, AnyOut, BodyCom, chipKIT, chipKIT logo, CodeGuard, CryptoAuthentication, CryptoCompanion, CryptoController, dsPICDEM, dsPICDEM.net, Dynamic Average Matching, DAM, ECAN, EtherGREEN, In-Circuit Serial Programming, ICSP, Inter-Chip Connectivity, JitterBlocker, KleerNet, KleerNet logo, Mindi, MiWi, motorBench, MPASM, MPF, MPLAB Certified logo, MPLIB, MPLINK, MultiTRAK, NetDetach, Omniscient Code Generation, PICDEM, PICDEM.net, PICkit, PICtail, PureSilicon, QMatrix, RightTouch logo, REAL ICE, Ripple Blocker, SAM-ICE, Serial Quad I/O, SMART-I.S., SQI, SuperSwitcher, SuperSwitcher II, Total Endurance, TSHARC, USBCheck, VariSense, ViewSpan, WiperLock, Wireless DNA, and ZENA are trademarks of Microchip Technology Incorporated in the U.S.A. and other countries.

SQTP is a service mark of Microchip Technology Incorporated in the U.S.A.

Silicon Storage Technology is a registered trademark of Microchip Technology Inc. in other countries.

GestIC is a registered trademark of Microchip Technology Germany II GmbH & Co. KG, a subsidiary of Microchip Technology Inc., in other countries.

All other trademarks mentioned herein are property of their respective companies.

© 2018, Microchip Technology Incorporated, Printed in the U.S.A., All Rights Reserved.

ISBN: 978-1-5224-3019-3

## **Quality Management System Certified by DNV**

---

### **ISO/TS 16949**

Microchip received ISO/TS-16949:2009 certification for its worldwide headquarters, design and wafer fabrication facilities in Chandler and Tempe, Arizona; Gresham, Oregon and design centers in California and India. The Company's quality system processes and procedures are for its PIC<sup>®</sup> MCUs and dsPIC<sup>®</sup> DSCs, KEELOQ<sup>®</sup> code hopping devices, Serial EEPROMs, microperipherals, nonvolatile memory and analog products. In addition, Microchip's quality system for the design and manufacture of development systems is ISO 9001:2000 certified.

## Worldwide Sales and Service

AMERICAS	ASIA/PACIFIC	ASIA/PACIFIC	EUROPE
<p><b>Corporate Office</b> 2355 West Chandler Blvd. Chandler, AZ 85224-6199 Tel: 480-792-7200 Fax: 480-792-7277 Technical Support: <a href="http://www.microchip.com/support">http://www.microchip.com/support</a> Web Address: <a href="http://www.microchip.com">www.microchip.com</a></p> <p><b>Atlanta</b> Duluth, GA Tel: 678-957-9614 Fax: 678-957-1455</p> <p><b>Austin, TX</b> Tel: 512-257-3370</p> <p><b>Boston</b> Westborough, MA Tel: 774-760-0087 Fax: 774-760-0088</p> <p><b>Chicago</b> Itasca, IL Tel: 630-285-0071 Fax: 630-285-0075</p> <p><b>Dallas</b> Addison, TX Tel: 972-818-7423 Fax: 972-818-2924</p> <p><b>Detroit</b> Novi, MI Tel: 248-848-4000</p> <p><b>Houston, TX</b> Tel: 281-894-5983</p> <p><b>Indianapolis</b> Noblesville, IN Tel: 317-773-8323 Fax: 317-773-5453 Tel: 317-536-2380</p> <p><b>Los Angeles</b> Mission Viejo, CA Tel: 949-462-9523 Fax: 949-462-9608 Tel: 951-273-7800</p> <p><b>Raleigh, NC</b> Tel: 919-844-7510</p> <p><b>New York, NY</b> Tel: 631-435-6000</p> <p><b>San Jose, CA</b> Tel: 408-735-9110 Tel: 408-436-4270</p> <p><b>Canada - Toronto</b> Tel: 905-695-1980 Fax: 905-695-2078</p>	<p><b>Australia - Sydney</b> Tel: 61-2-9868-6733</p> <p><b>China - Beijing</b> Tel: 86-10-8569-7000</p> <p><b>China - Chengdu</b> Tel: 86-28-8665-5511</p> <p><b>China - Chongqing</b> Tel: 86-23-8980-9588</p> <p><b>China - Dongguan</b> Tel: 86-769-8702-9880</p> <p><b>China - Guangzhou</b> Tel: 86-20-8755-8029</p> <p><b>China - Hangzhou</b> Tel: 86-571-8792-8115</p> <p><b>China - Hong Kong SAR</b> Tel: 852-2943-5100</p> <p><b>China - Nanjing</b> Tel: 86-25-8473-2460</p> <p><b>China - Qingdao</b> Tel: 86-532-8502-7355</p> <p><b>China - Shanghai</b> Tel: 86-21-3326-8000</p> <p><b>China - Shenyang</b> Tel: 86-24-2334-2829</p> <p><b>China - Shenzhen</b> Tel: 86-755-8864-2200</p> <p><b>China - Suzhou</b> Tel: 86-186-6233-1526</p> <p><b>China - Wuhan</b> Tel: 86-27-5980-5300</p> <p><b>China - Xian</b> Tel: 86-29-8833-7252</p> <p><b>China - Xiamen</b> Tel: 86-592-2388138</p> <p><b>China - Zhuhai</b> Tel: 86-756-3210040</p>	<p><b>India - Bangalore</b> Tel: 91-80-3090-4444</p> <p><b>India - New Delhi</b> Tel: 91-11-4160-8631</p> <p><b>India - Pune</b> Tel: 91-20-4121-0141</p> <p><b>Japan - Osaka</b> Tel: 81-6-6152-7160</p> <p><b>Japan - Tokyo</b> Tel: 81-3-6880-3770</p> <p><b>Korea - Daegu</b> Tel: 82-53-744-4301</p> <p><b>Korea - Seoul</b> Tel: 82-2-554-7200</p> <p><b>Malaysia - Kuala Lumpur</b> Tel: 60-3-7651-7906</p> <p><b>Malaysia - Penang</b> Tel: 60-4-227-8870</p> <p><b>Philippines - Manila</b> Tel: 63-2-634-9065</p> <p><b>Singapore</b> Tel: 65-6334-8870</p> <p><b>Taiwan - Hsin Chu</b> Tel: 886-3-577-8366</p> <p><b>Taiwan - Kaohsiung</b> Tel: 886-7-213-7830</p> <p><b>Taiwan - Taipei</b> Tel: 886-2-2508-8600</p> <p><b>Thailand - Bangkok</b> Tel: 66-2-694-1351</p> <p><b>Vietnam - Ho Chi Minh</b> Tel: 84-28-5448-2100</p>	<p><b>Austria - Wels</b> Tel: 43-7242-2244-39 Fax: 43-7242-2244-393</p> <p><b>Denmark - Copenhagen</b> Tel: 45-4450-2828 Fax: 45-4485-2829</p> <p><b>Finland - Espoo</b> Tel: 358-9-4520-820</p> <p><b>France - Paris</b> Tel: 33-1-69-53-63-20 Fax: 33-1-69-30-90-79</p> <p><b>Germany - Garching</b> Tel: 49-8931-9700</p> <p><b>Germany - Haan</b> Tel: 49-2129-3766400</p> <p><b>Germany - Heilbronn</b> Tel: 49-7131-67-3636</p> <p><b>Germany - Karlsruhe</b> Tel: 49-721-625370</p> <p><b>Germany - Munich</b> Tel: 49-89-627-144-0 Fax: 49-89-627-144-44</p> <p><b>Germany - Rosenheim</b> Tel: 49-8031-354-560</p> <p><b>Israel - Ra'anana</b> Tel: 972-9-744-7705</p> <p><b>Italy - Milan</b> Tel: 39-0331-742611 Fax: 39-0331-466781</p> <p><b>Italy - Padova</b> Tel: 39-049-7625286</p> <p><b>Netherlands - Drunen</b> Tel: 31-416-690399 Fax: 31-416-690340</p> <p><b>Norway - Trondheim</b> Tel: 47-7289-7561</p> <p><b>Poland - Warsaw</b> Tel: 48-22-3325737</p> <p><b>Romania - Bucharest</b> Tel: 40-21-407-87-50</p> <p><b>Spain - Madrid</b> Tel: 34-91-708-08-90 Fax: 34-91-708-08-91</p> <p><b>Sweden - Gothenberg</b> Tel: 46-31-704-60-40</p> <p><b>Sweden - Stockholm</b> Tel: 46-8-5090-4654</p> <p><b>UK - Wokingham</b> Tel: 44-118-921-5800 Fax: 44-118-921-5820</p>

# Mouser Electronics

Authorized Distributor

Click to View Pricing, Inventory, Delivery & Lifecycle Information:

[Microchip:](#)

[ATTINY1614-SSF](#) [ATTINY1614-SSN](#)



Компания «Океан Электроники» предлагает заключение долгосрочных отношений при поставках импортных электронных компонентов на взаимовыгодных условиях!

Наши преимущества:

- Поставка оригинальных импортных электронных компонентов напрямую с производств Америки, Европы и Азии, а так же с крупнейших складов мира;
- Широкая линейка поставок активных и пассивных импортных электронных компонентов (более 30 млн. наименований);
- Поставка сложных, дефицитных, либо снятых с производства позиций;
- Оперативные сроки поставки под заказ (от 5 рабочих дней);
- Экспресс доставка в любую точку России;
- Помощь Конструкторского Отдела и консультации квалифицированных инженеров;
- Техническая поддержка проекта, помощь в подборе аналогов, поставка прототипов;
- Поставка электронных компонентов под контролем ВП;
- Система менеджмента качества сертифицирована по Международному стандарту ISO 9001;
- При необходимости вся продукция военного и аэрокосмического назначения проходит испытания и сертификацию в лаборатории (по согласованию с заказчиком);
- Поставка специализированных компонентов военного и аэрокосмического уровня качества (Xilinx, Altera, Analog Devices, Intersil, Interpoint, Microsemi, Actel, Aeroflex, Peregrine, VPT, Syfer, Eurofarad, Texas Instruments, MS Kennedy, Miteq, Cobham, E2V, MA-COM, Hittite, Mini-Circuits, General Dynamics и др.);

Компания «Океан Электроники» является официальным дистрибьютором и эксклюзивным представителем в России одного из крупнейших производителей разъемов военного и аэрокосмического назначения «**JONHON**», а так же официальным дистрибьютором и эксклюзивным представителем в России производителя высокотехнологичных и надежных решений для передачи СВЧ сигналов «**FORSTAR**».



## JONHON

«**JONHON**» (основан в 1970 г.)

Разъемы специального, военного и аэрокосмического назначения:

(Применяются в военной, авиационной, аэрокосмической, морской, железнодорожной, горно- и нефтедобывающей отраслях промышленности)

«**FORSTAR**» (основан в 1998 г.)

ВЧ соединители, коаксиальные кабели,  
кабельные сборки и микроволновые компоненты:

(Применяются в телекоммуникациях гражданского и специального назначения, в средствах связи, РЛС, а так же военной, авиационной и аэрокосмической отраслях промышленности).



Телефон: 8 (812) 309-75-97 (многоканальный)

Факс: 8 (812) 320-03-32

Электронная почта: [ocean@oceanchips.ru](mailto:ocean@oceanchips.ru)

Web: <http://oceanchips.ru/>

Адрес: 198099, г. Санкт-Петербург, ул. Калинина, д. 2, корп. 4, лит. А