



MCP1630 1A Bias Supply Demo Board User's Guide

Note the following details of the code protection feature on Microchip devices:

- Microchip products meet the specification contained in their particular Microchip Data Sheet.
- Microchip believes that its family of products is one of the most secure families of its kind on the market today, when used in the intended manner and under normal conditions.
- There are dishonest and possibly illegal methods used to breach the code protection feature. All of these methods, to our knowledge, require using the Microchip products in a manner outside the operating specifications contained in Microchip's Data Sheets. Most likely, the person doing so is engaged in theft of intellectual property.
- Microchip is willing to work with the customer who is concerned about the integrity of their code.
- Neither Microchip nor any other semiconductor manufacturer can guarantee the security of their code. Code protection does not mean that we are guaranteeing the product as "unbreakable."

Code protection is constantly evolving. We at Microchip are committed to continuously improving the code protection features of our products. Attempts to break Microchip's code protection feature may be a violation of the Digital Millennium Copyright Act. If such acts allow unauthorized access to your software or other copyrighted work, you may have a right to sue for relief under that Act.

Information contained in this publication regarding device applications and the like is provided only for your convenience and may be superseded by updates. It is your responsibility to ensure that your application meets with your specifications. MICROCHIP MAKES NO REPRESENTATIONS OR WARRANTIES OF ANY KIND WHETHER EXPRESS OR IMPLIED, WRITTEN OR ORAL, STATUTORY OR OTHERWISE, RELATED TO THE INFORMATION, INCLUDING BUT NOT LIMITED TO ITS CONDITION, QUALITY, PERFORMANCE, MERCHANTABILITY OR FITNESS FOR PURPOSE. Microchip disclaims all liability arising from this information and its use. Use of Microchip's products as critical components in life support systems is not authorized except with express written approval by Microchip. No licenses are conveyed, implicitly or otherwise, under any Microchip intellectual property rights.

Trademarks

The Microchip name and logo, the Microchip logo, Accuron, dsPIC, KEELOQ, microID, MPLAB, PIC, PICmicro, PICSTART, PRO MATE, PowerSmart, rfPIC, and SmartShunt are registered trademarks of Microchip Technology Incorporated in the U.S.A. and other countries.

AmpLab, FilterLab, Migratable Memory, MXDEV, MXLAB, PICMASTER, SEEVAL, SmartSensor and The Embedded Control Solutions Company are registered trademarks of Microchip Technology Incorporated in the U.S.A.

Analog-for-the-Digital Age, Application Maestro, dsPICDEM, dsPICDEM.net, dsPICworks, ECAN, ECONOMONITOR, FanSense, FlexROM, fuzzyLAB, In-Circuit Serial Programming, ICSP, ICEPIC, Linear Active Thermistor, MPASM, MPLIB, MPLINK, MPSIM, PICKit, PICDEM, PICDEM.net, PICLAB, PICtail, PowerCal, PowerInfo, PowerMate, PowerTool, rLAB, rfPICDEM, Select Mode, Smart Serial, SmartTel, Total Endurance and WiperLock are trademarks of Microchip Technology Incorporated in the U.S.A. and other countries.

SQTP is a service mark of Microchip Technology Incorporated in the U.S.A.

All other trademarks mentioned herein are property of their respective companies.

© 2005, Microchip Technology Incorporated, Printed in the U.S.A., All Rights Reserved.

 Printed on recycled paper.

**QUALITY MANAGEMENT SYSTEM
CERTIFIED BY DNV
== ISO/TS 16949:2002 ==**

Microchip received ISO/TS-16949:2002 quality system certification for its worldwide headquarters, design and wafer fabrication facilities in Chandler and Tempe, Arizona and Mountain View, California in October 2003. The Company's quality system processes and procedures are for its PICmicro® 8-bit MCUs, KEELOQ® code hopping devices, Serial EEPROMs, microperipherals, nonvolatile memory and analog products. In addition, Microchip's quality system for the design and manufacture of development systems is ISO 9001:2000 certified.



MCP1630 1A BIAS SUPPLY DEMO BOARD USER'S GUIDE

Table of Contents

Preface	1
Chapter 1. Product Overview	5
1.1 Introduction	5
1.2 What is the MCP1630 1A Bias Supply Demo Board?	6
1.3 What the MCP1630 1A Bias Supply Demo Board Kit Includes	6
Chapter 2. Installation and Operation	7
2.1 Introduction	7
2.2 Features	7
2.3 Getting Started	8
Appendix A. Schematic and Layouts	11
A.1 Introduction	11
A.2 Board Schematic	12
A.3 Board – Assembly Drawing	13
A.4 Board – Top Overlay	14
A.5 Board – Top Layer	15
A.6 Board – Bottom Layer	16
Appendix B. Bill-Of-Materials (BOM)	17
Appendix C. Evaluation Board Firmware	19
C.1 Device Firmware	19
Worldwide Sales and Service	20

MCP1630 1A Bias Supply Demo Board User's Guide

NOTES:



MCP1630 1A BIAS SUPPLY DEMO BOARD USER'S GUIDE

Preface

NOTICE TO CUSTOMERS

All documentation becomes dated, and this manual is no exception. Microchip tools and documentation are constantly evolving to meet customer needs, so some actual dialogs and/or tool descriptions may differ from those in this document. Please refer to our web site (www.microchip.com) to obtain the latest documentation available.

Documents are identified with a "DS" number. This number is located on the bottom of each page, in front of the page number. The numbering convention for the DS number is "DSXXXXA", where "XXXX" is the document number and "A" is the revision level of the document.

INTRODUCTION

This chapter contains general information that will be useful to know before using the MCP1630 1A Bias Supply Demo Board. Items discussed in this chapter include:

- Document Layout
- Conventions Used in this Guide
- Recommended Reading
- The Microchip Web Site
- Customer Support
- Document Revision History

DOCUMENT LAYOUT

This document describes how to use the MCP1630 1A Bias Supply Demo Board. The manual layout is as follows:

- **Chapter 1. "Product Overview"** – Important information about the MCP1630 1A Bias Supply Demo Board.
- **Chapter 2. "Installation and Operation"** – Includes a description of the demo board, as well as instructions on how to get started.
- **Appendix A. "Schematic and Layouts"** – Shows the schematic and layout diagrams for the MCP1630 1A Bias Supply Demo Board.
- **Appendix B. "Bill-Of-Materials (BOM)"** – Lists the parts used to build the MCP1630 1A Bias Supply Demo Board.
- **Appendix C. "Evaluation Board Firmware"** – Provides information about the application firmware and the location of the source code.

MCP1630 1A Bias Supply Demo Board User's Guide

CONVENTIONS USED IN THIS GUIDE

This manual uses the following documentation conventions:

DOCUMENTATION CONVENTIONS

Description	Represents	Examples
Arial font:		
Italic characters	Referenced books	<i>MPLAB[®] IDE User's Guide</i>
	Emphasized text	...is the <i>only</i> compiler...
Initial caps	A window	the Output window
	A dialog	the Settings dialog
	A menu selection	select Enable Programmer
Quotes	A field name in a window or dialog	"Save project before build"
Underlined, italic text with right angle bracket	A menu path	<u><i>File</i></u> >Save
Bold characters	A dialog button	Click OK
	A tab	Click the Power tab
Text in angle brackets < >	A key on the keyboard	Press <Enter>, <F1>
Courier font:		
Plain Courier	Sample source code	#define START
	Filenames	autoexec.bat
	File paths	c:\mcc18\h
	Keywords	_asm, _endasm, static
	Command-line options	-Opa+, -Opa-
	Bit values	0, 1
	Constants	0xFF, 'A'
Italic Courier	A variable argument	<i>file.o</i> , where <i>file</i> can be any valid filename
Square brackets []	Optional arguments	mcc18 [options] <i>file</i> [options]
Curly brackets and pipe character: { }	Choice of mutually exclusive arguments; an OR selection	errorlevel {0 1}
Ellipses...	Replaces repeated text	var_name [, var_name...]
	Represents code supplied by user	void main (void) { ... }

RECOMMENDED READING

This user's guide describes how to use MCP1630 1A Bias Supply Demo Board. The following Microchip documents are available and recommended as supplemental reference resources.

MCP1630 Data Sheet, “High-Speed, Microcontroller-Adaptable, Pulse Width Modulator”, (DS21896)

This data sheet provides detailed information regarding the MCP1630 product family.

MCP1701 Data Sheet, “2 μ A Low-Dropout Positive Voltage Regulator”, (DS21874)

This data sheet provides detailed information regarding the MCP1701 product family.

PIC10F200 Data Sheet, “6-Pin, 8-Bit Flash Microcontrollers”, (DS41239)

This data sheet provides detailed information regarding the PIC10F200 product family.

THE MICROCHIP WEB SITE

Microchip provides online support via our web site at www.microchip.com. This web site is used as a means to make files and information easily available to customers. Accessible by using your favorite Internet browser, the web site contains the following information:

- **Product Support** – Data sheets and errata, application notes and sample programs, design resources, user's guides and hardware support documents, latest software releases and archived software
- **General Technical Support** – Frequently Asked Questions (FAQs), technical support requests, online discussion groups, Microchip consultant program member listing
- **Business of Microchip** – Product selector and ordering guides, latest Microchip press releases, listing of seminars and events, listings of Microchip sales offices, distributors and factory representatives

MCP1630 1A Bias Supply Demo Board User's Guide

CUSTOMER SUPPORT

Users of Microchip products can receive assistance through several channels:

- Distributor or Representative
- Local Sales Office
- Field Application Engineer (FAE)
- Technical Support
- Development Systems Information Line

Customers should contact their distributor, representative or field application engineer (FAE) for support. Local sales offices are also available to help customers. A listing of sales offices and locations is included in the back of this document.

Technical support is available through the web site at: <http://support.microchip.com>

DOCUMENT REVISION HISTORY

Revision A (June 2005)

- Initial Release of this Document.

Chapter 1. Product Overview

1.1 INTRODUCTION

The MCP1630 1A Bias Supply Demo Board is used to evaluate Microchip's MCP1630 in a SEPIC power converter application. As provided, the MCP1630 1A Bias Supply Demo Board generates a 3.3V or 5.0V output from an input voltage of 9V, $\pm 20\%$. The MCP1630 1A Bias Supply Demo Board provides a regulated output for load currents up to 1A.

This chapter covers the following topics:

- What is the MCP1630 1A Bias Supply Demo Board?
- What the MCP1630 1A Bias Supply Demo Board Kit Includes

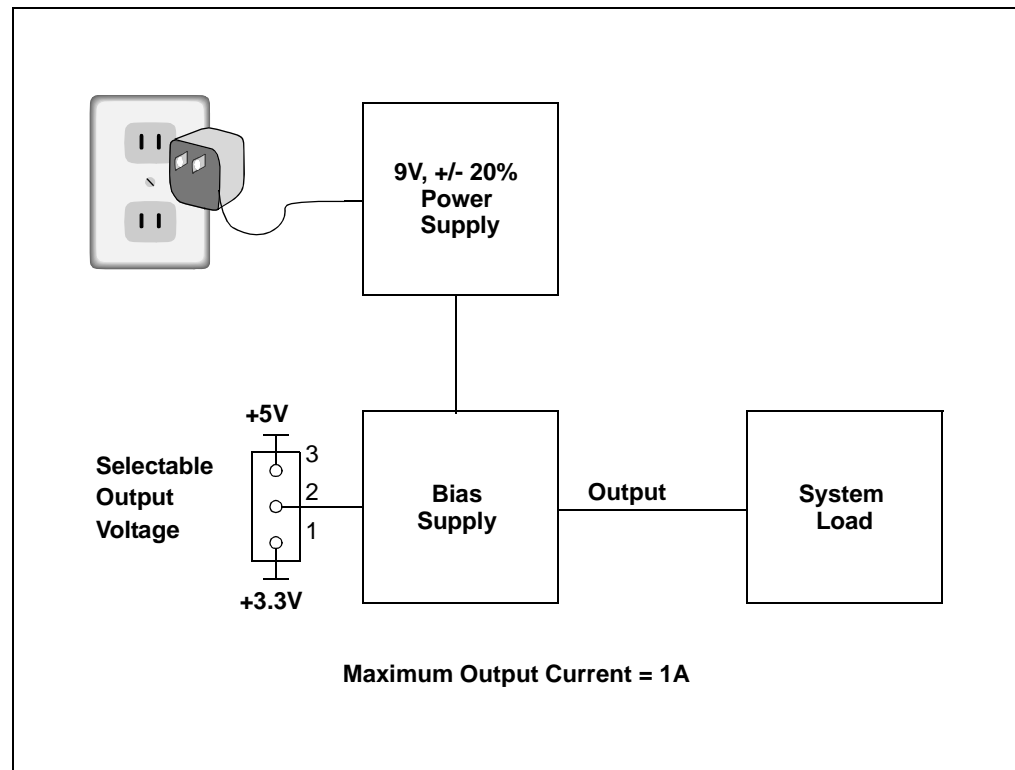

FIGURE 1-1: MCP1630 1A Bias Supply Demo Board System Block Diagram.

MCP1630 1A Bias Supply Demo Board User's Guide

1.2 WHAT IS THE MCP1630 1A BIAS SUPPLY DEMO BOARD?

The MCP1630 1A Bias Supply Demo Board is a complete, step-down, switch-mode, dc-dc power converter. The MCP1630 1A Bias Supply Demo Board generates a regulated output voltage for systems requiring a bias of 3.3V or 5V at load currents up to 1A. Different output voltages can be obtained with minor modifications to the firmware and/or hardware.

This board utilizes Microchip's MCP1630 (High-Speed PIC[®] MCU PWM MSOP8), MCP1701 (Low-Dropout Linear Regulator SOT-23A) and PIC10F200 (Flash MCU SOT23-6). The input voltage range for the demo board is 7.2V to 11.8V. The output is capable of providing up to 1A constant output current.

An input power jack is provided to apply the input voltage to the bias supply. An output header is provided as a means to connect the external system load. A programming header is available for updating the firmware contained in the PIC10F200.

1.3 WHAT THE MCP1630 1A BIAS SUPPLY DEMO BOARD KIT INCLUDES

This MCP1630 1A Bias Supply Demo Board Kit includes:

- The MCP1630 1A Bias Supply Demo Board Board (102-00046)
- MCP1630 1A Bias Supply Demo Board User's Guide (DS51564A).
- MCP1630 Data Sheet, "*High-Speed, Microcontroller-Adaptable, Pulse Width Modulator*", (DS21896)
- MCP1701 Data Sheet, "*2 μ A Low-Dropout Positive Voltage Regulator*", (DS21874)
- PIC10F200 Data Sheet, "*6-Pin, 8-Bit Flash Microcontrollers*", (DS41239)

Chapter 2. Installation and Operation

2.1 INTRODUCTION

The MCP1630 1A Bias Supply Demo Board demonstrates Microchip's MCP1630 high-speed Pulse Width Modulator (PWM) used in a step-down, switch-mode, dc-dc power converter. The MCP1630 is a high-speed, microcontroller-adaptable PWM. When used in conjunction with a microcontroller, the MCP1630 will control the power system duty cycle to provide output voltage or current regulation. The PIC10F200 microcontroller can be used to regulate output voltage or current, switching frequency and maximum duty cycle. The MCP1630 generates duty cycle and provides fast overcurrent protection based on various external inputs. External signals include the input oscillator, the reference voltage, the feedback voltage and the current sense. The output signal is a square-wave pulse. The power train used for the MCP1630 1A Bias Supply Demo Board is a Single-Ended Primary Inductive Converter (SEPIC).

2.2 FEATURES

The MCP1630 1A Bias Supply Demo Board has the following features:

- Selectable regulated output voltage: 3.3V or 5.0V
- Maximum output current: 1A
- Foldback current limiting
- Cycle-by-cycle peak current limit
- Output present indicator
- Soft-start capability by holding the reference voltage low during power-up
- The MCP1630 1A Bias Supply Demo Board has the flexibility to modify the regulated output voltage, optimize the soft-start time or disable the output by modifying the firmware contained in the PIC10F200
- Proprietary features can be added by modifying the firmware contained in the PIC10F200
- The factory-programmed source code is available
- Adaptable to environmental effects such as ambient temperature
- Typical efficiency: 85%

MCP1630 1A Bias Supply Demo Board User's Guide

2.3 GETTING STARTED

The MCP1630 1A Bias Supply Demo Board is fully assembled and tested for generating a regulated, selectable 3.3V or 5.0V output voltage. The MCP1630 1A Bias Supply Demo Board requires the use of an external input voltage source (+9V, $\pm 20\%$).

2.3.1 Power Input and Output Connections

Powering the MCP1630 1A Bias Supply Demo Board

1. Apply the input voltage to the input power jack (J2). The input voltage source should be limited to the 0V to +11.8V range. For normal operation, the input voltage should be between +7.2V and +11.8V, not to exceed an absolute maximum of +12V.
2. The inside portion of the input power plug must be positive. The outer jacket of the input power plug must be negative. Refer to Figure 2-1.

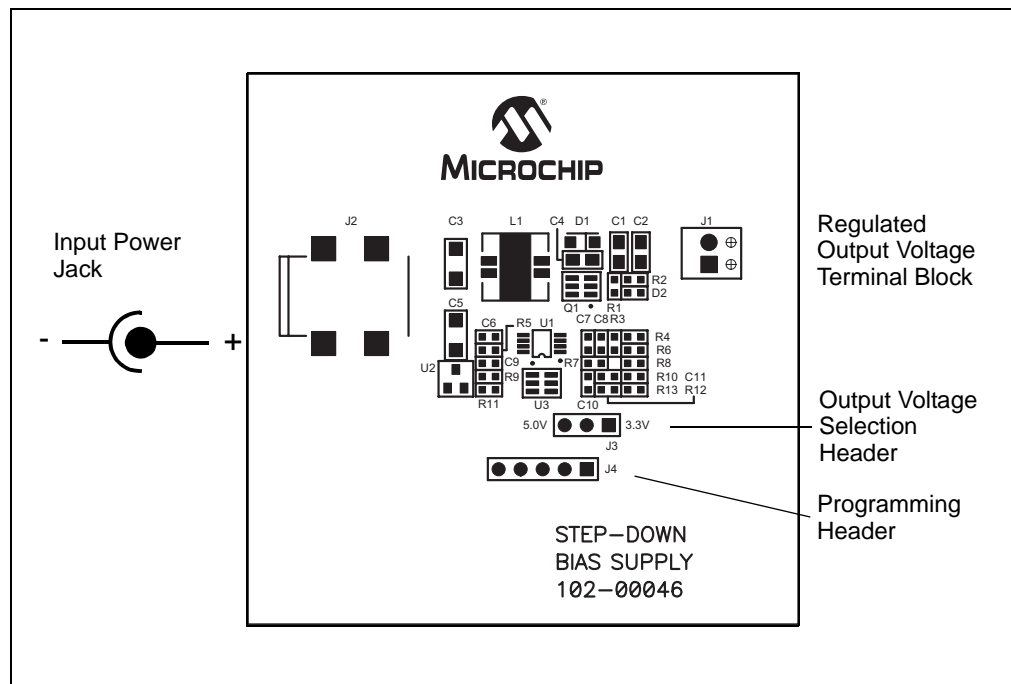

FIGURE 2-1: Set-Up Configuration Diagram.

Apply the load to the regulated output voltage terminal block

1. To apply a load to the MCP1630 1A Bias Supply Demo Board, the positive side (+) of the load should be connected to pin 2 of J1. The negative side (-) of the load should be connected to pin 1 of J1. Care should be taken when using electronic loads.

Regulated output voltage selection

1. The regulated output voltage can be selected to be either 3.3V or 5.0V. The regulated output voltage is selected by placing a shorting jumper on the Output Voltage Selection Header (J3). By shorting pins 1 and 2, the regulated output voltage will be 3.3V. By shorting pins 2 and 3, the regulated output voltage will be 5.0V.
2. If a shorting jumper is not present, the regulated output voltage will default to 5.0V.
3. The output voltage selection input is read by the PIC10F200 at power-up only. Therefore, the output voltage cannot be changed dynamically without modification of the factory-installed firmware. Input power must be removed or cycled in order for a change to take effect.

Output voltage present indication

The MCP1630 1A Bias Supply Demo Board has a LED to indicate the presence of output voltage. The LED will be illuminated when the output voltage is present.

Programming

Header J4 is provided for in-system circuit programming.

MCP1630 1A Bias Supply Demo Board User's Guide

NOTES:



MCP1630 1A BIAS SUPPLY DEMO BOARD USER'S GUIDE

Appendix A. Schematic and Layouts

A.1 INTRODUCTION

This appendix contains the following schematics and layouts for the MCP1630 1A Bias Supply Demo Board:

- Board Schematic
- Board – Assembly Drawing
- Board – Top Overlay
- Board – Top Layer
- Board – Bottom Layer

MCP1630 1A Bias Supply Demo Board User's Guide

A.2 BOARD SCHEMATIC

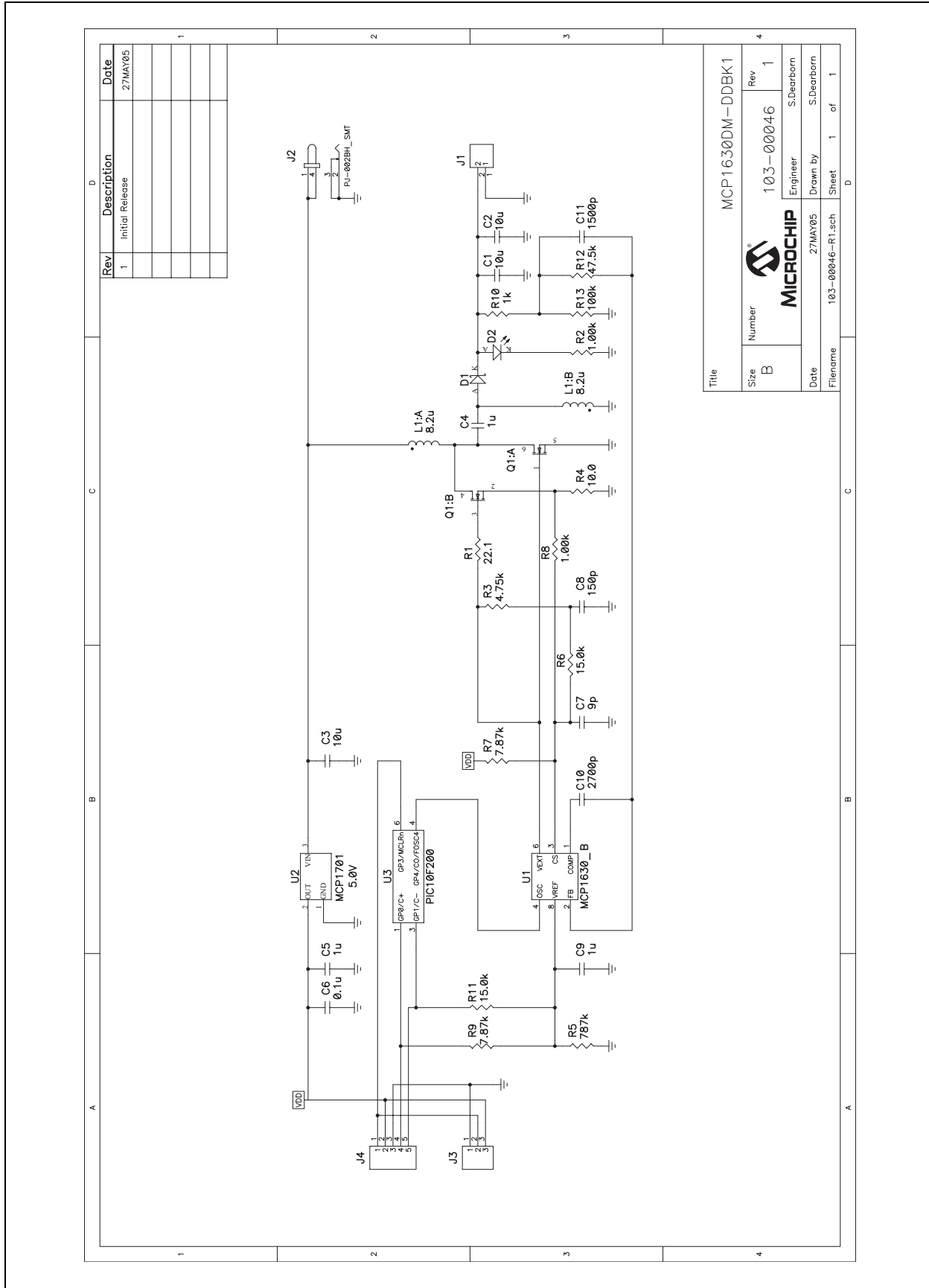

A.3 BOARD – ASSEMBLY DRAWING

A	B	C	D
1	2	3	4

NOTES:

MATERIAL: FR-4, THICKNESS 0.062, COPPER 1 OZ – SIG LYRS

TWO LAYER BOARD

FINISH:

- SOLDERMASK OVER BARE COPPER (SMOBC) WITH HOT-AIR-LEVELED SOLDER
- SMOBC WITH SELECTIVE GOLD PLATING ON LANDS INDICATED. 10µi GOLD OVER 50-100µi NICKEL.
- 60/40 TIN-LEAD REFLOW

SOLDERMASK – DYNACHEM EPIC 200 LPI OR EQUIVALENT.
 COLOR-Green High Gloss
 SILKSCREEN – White

USE ARTWORK SET NO. 105-00046 REV 1

ANY ALTERNATIVES TO THE ABOVE SPECIFICATIONS MUST BE APPROVED BY THE ENGINEERING DEPARTMENT AT MICROCHIP.
 THIS PCB TO BE MANUFACTURED TO MEET ALL ACCEPTANCE LEVELS OF A CLASS 2 PCB PER ANSI/IPC-A-600F.

Hole Dia. (Inch)	Symbol	Quantity	Plated
0.545	X	20	Yes
0.945	Y	2	No
0.945	Y	2	No
0.872	X	2	No

STEP-DOWN
 PDS SUPPLY
 105-00046

ASSEMBLY NOTES:

1. ALL UNUSED COMPONENTS SHALL BE FREE OF SOLDER.
2. ALL COMPONENTS SHALL BE MOUNTED FLUSH TO THE BOARD, EXCEPT AS NOTED.
3. MAXIMUM COMPONENT HEIGHT NOT TO EXCEED: 0.500 TOP SIDE, 0.048 BOTTOM SIDE.
4. FINISHED BOARD SHALL BE FREE OF ALL RESIDUES.
5. THESE COMPONENTS REQUIRE SOCKETS.
6. ALL LEADS SHALL BE TRIMED TO A MAXIMUM LEIGHT OF 0.045.

REV	DESCRIPTION	DATE	
1	Initial Design	27MAY05	

Title	MCP1630DM-DBBK1		
Size	B	Number	104-00046
Date	27MAY05	Engineer	S.beerborn
Filename	104-00046-R1.pcb	Drawn by	S.beerborn
		Sheet	1 of 1

MCP1630 1A Bias Supply Demo Board User's Guide

A.4 BOARD – TOP OVERLAY

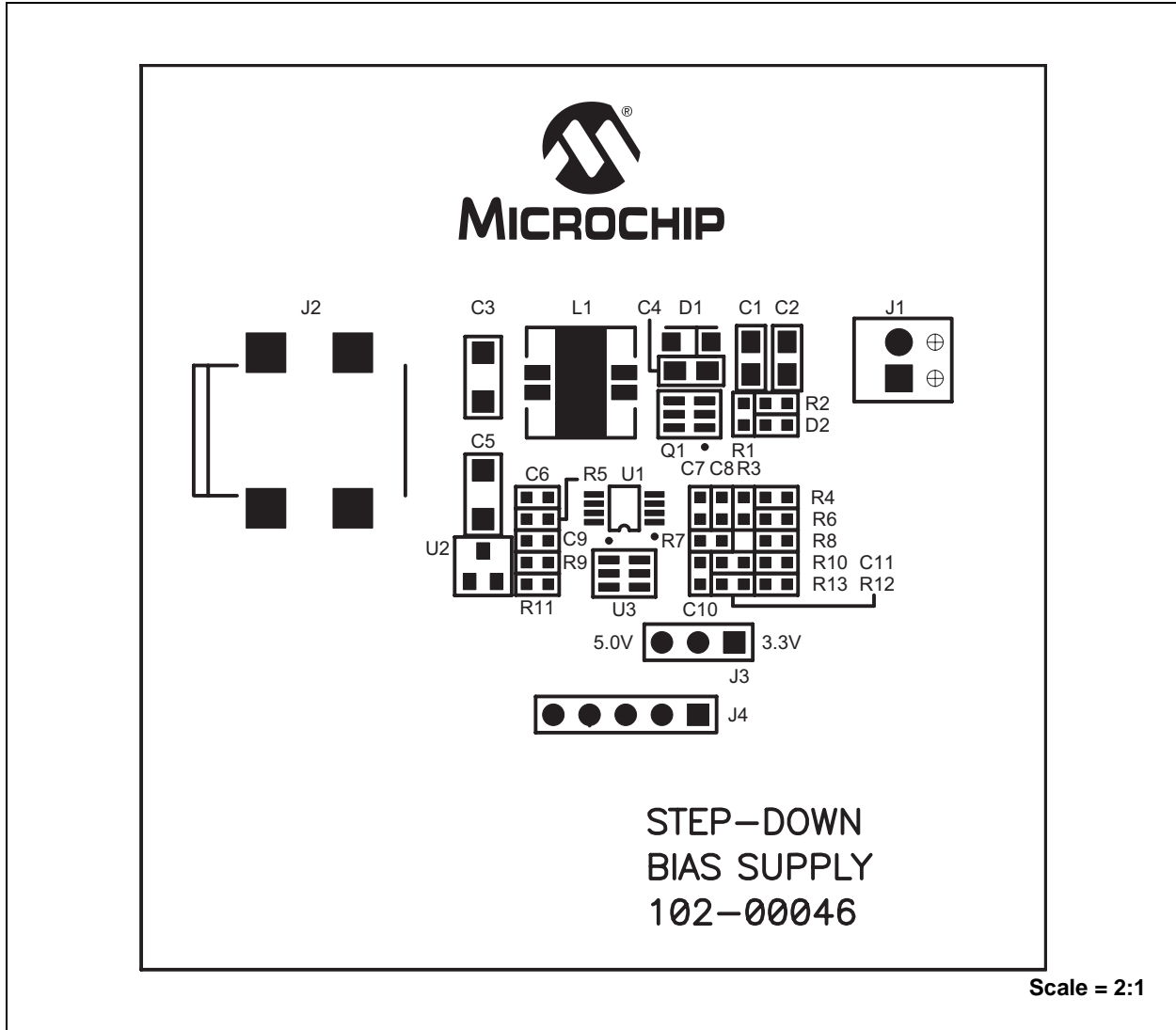

A.5 BOARD – TOP LAYER

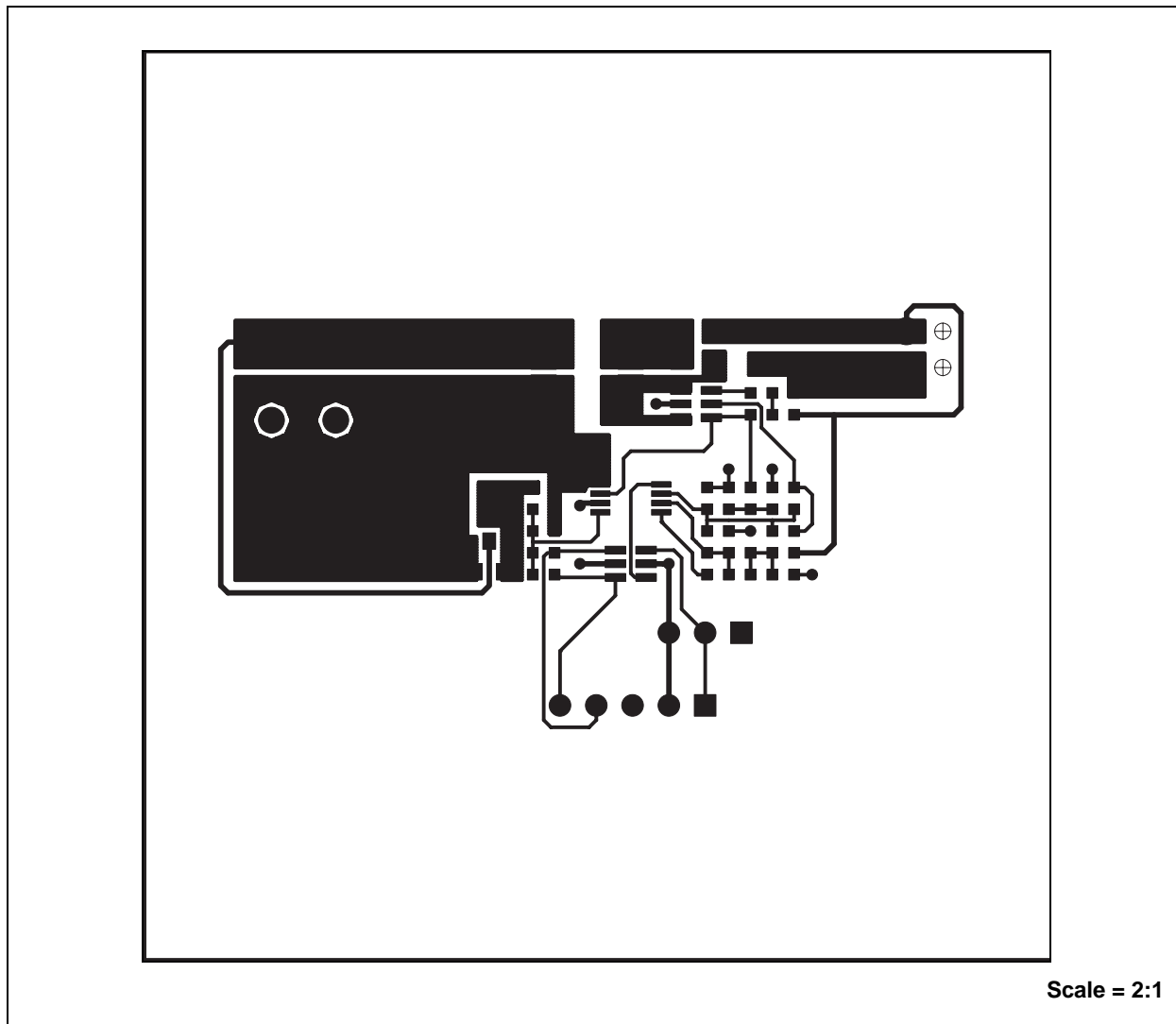

MCP1630 1A Bias Supply Demo Board User's Guide

A.6 BOARD – BOTTOM LAYER

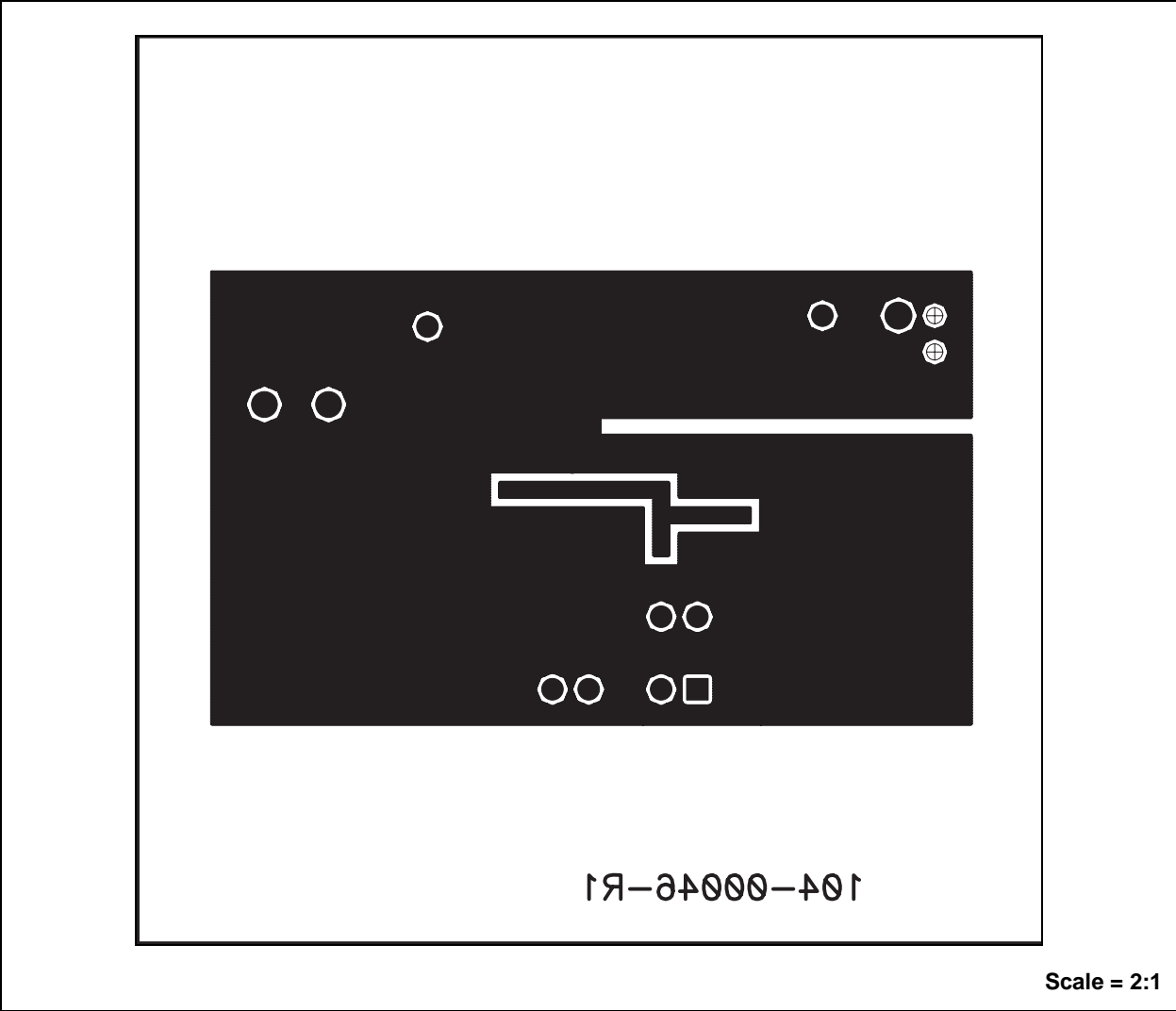

Appendix B. Bill-Of-Materials (BOM)

TABLE B-1: BILL-OF-MATERIALS (BOM)

Qty.	Reference	Description	Mfgr.	Part Number
2	C1,C2	10 μ F, X5R Ceramic, 6.3V, 0805	Panasonic [®] -ECG	ECJ-2FB0J106M
1	C3	10 μ F, X5R Ceramic, 25V, 1206	Panasonic-ECG	ECJ-3YB1E106M
1	C4	1 μ F, X5R Ceramic, 16V, 0805	Panasonic-ECG	ECJ-2FB1C105K
1	C5	1 μ F, Tantalum, 16V, 1206	Kemet [®] Electronics [®]	T491A105K016AS
1	C6	0.1 μ F, X7R Ceramic, 16V, 0603	Panasonic-ECG	ECJ-1VB1C104K
1	C7	9 pF, NPO Ceramic, 50V, 0603	Panasonic-ECG	ECJ-1VC1H090D
1	C8	150 pF, NPO Ceramic, 50V, 0603	Panasonic-ECG	ECJ-1VC1H151J
1	C9	1 μ F, X7R Ceramic, 6.3V, 0603	Panasonic-ECG	ECJ-1VB0J105K
1	C10	2700 pF, X7R Ceramic, 50V, 0603	Panasonic-ECG	ECJ-1VB1H272K
1	C11	1500 pF, X7R Ceramic, 50V, 0603	Panasonic-ECG	ECJ-1VB1H152K
1	D1	1.5A, 30V Schottky Diode, SMA	Toshiba [®]	CRS08(TE85L)
1	D2	Super Red LED, 0603	Lumex [®] Opto/Components	SML-LX0603SRW-TR
1	J1	Connector Terminal Block, 2 Pos., 2.54mm, TB254-2	Phoenix Contact	1725656
1	J2	Connector Power Jack, 2.5 x 5.5 mm, SMD	CUI Inc.	PJ-002B-SMT
1	J3	Connector Header, 3 Pos., 2.54 mm, HDR1X3	Molex [®] /Waldom [®]	22-03-2031
1	J4	Connector Header, 5 Pos., 2.54 mm, HDR1X5	Molex	22-03-2051
1	L1	8.2 μ H, Coupled Inductor, DRQ74	Coiltronics [®]	DRQ74-8R2
1	Q1	Dual N-Channel MOSFET, SOT23-6	Siliconix	Si3900DV-T1
1	R1	22.1, 1/16W, 1%, Chip Resistor, 0603	Panasonic-ECG	ERJ-3EKF22R1V
3	R2,R8,R10	1.00k, 1/16W, 1%, Chip Resistor, 0603	Panasonic-ECG	ERJ-3EKF1001V
1	R3	4.75k, 1/16W, 1%, Chip Resistor, 0603	Panasonic-ECG	ERJ-3EKF4751V
1	R4	10.0, 1/16W, 1%, Chip Resistor, 0603	Panasonic-ECG	ERJ-3EKF10R0V
1	R5	787k, 1/16W, 1%, Chip Resistor, 0603	Panasonic-ECG	ERJ-3EKF7873V
2	R6,R11	15.0k, 1/16W, 1%, Chip Resistor, 0603	Panasonic-ECG	ERJ-3EKF1502V
2	R7,R9	7.87k, 1/16W, 1%, Chip Resistor, 0603	Panasonic-ECG	ERJ-3EKF7871V
1	R12	47.5k, 1/16W, 1%, Chip Resistor, 0603	Panasonic-ECG	ERJ-3EKF4752V
1	R13	100k, 1/16W, 1%, Chip Resistor, 0603	Panasonic-ECG	ERJ-3EKF1003V
1	U1	5.0V, 250 mA, Voltage Regulator, SOT23	Microchip Technology Inc.	MCP1701T-5002I/CB
1	U2	PWM Building Block, MSOP8	Microchip Technology Inc.	MCP1630-E/MS
1	U3	8-Bit Flash Microcontroller, SOT23-6	Microchip Technology Inc.	PIC10F200T-I/OT
1		Shorting Jumper, 2 Pos., 2.54mm	Sullins [™]	STC025YAN

MCP1630 1A Bias Supply Demo Board User's Guide

NOTES:



MCP1630 1A BIAS SUPPLY DEMO BOARD USER'S GUIDE

Appendix C. Evaluation Board Firmware

C.1 DEVICE FIRMWARE

For the latest copy of the MCP1630 1A Bias Supply Demo Board firmware, visit our web site at www.microchip.com.



WORLDWIDE SALES AND SERVICE

AMERICAS

Corporate Office
2355 West Chandler Blvd.
Chandler, AZ 85224-6199
Tel: 480-792-7200
Fax: 480-792-7277
Technical Support:
<http://support.microchip.com>
Web Address:
www.microchip.com

Atlanta
Alpharetta, GA
Tel: 770-640-0034
Fax: 770-640-0307

Boston
Westborough, MA
Tel: 774-760-0087
Fax: 774-760-0088

Chicago
Itasca, IL
Tel: 630-285-0071
Fax: 630-285-0075

Dallas
Addison, TX
Tel: 972-818-7423
Fax: 972-818-2924

Detroit
Farmington Hills, MI
Tel: 248-538-2250
Fax: 248-538-2260

Kokomo
Kokomo, IN
Tel: 765-864-8360
Fax: 765-864-8387

Los Angeles
Mission Viejo, CA
Tel: 949-462-9523
Fax: 949-462-9608

San Jose
Mountain View, CA
Tel: 650-215-1444
Fax: 650-961-0286

Toronto
Mississauga, Ontario,
Canada
Tel: 905-673-0699
Fax: 905-673-6509

ASIA/PACIFIC

Australia - Sydney
Tel: 61-2-9868-6733
Fax: 61-2-9868-6755

China - Beijing
Tel: 86-10-8528-2100
Fax: 86-10-8528-2104

China - Chengdu
Tel: 86-28-8676-6200
Fax: 86-28-8676-6599

China - Fuzhou
Tel: 86-591-8750-3506
Fax: 86-591-8750-3521

China - Hong Kong SAR
Tel: 852-2401-1200
Fax: 852-2401-3431

China - Shanghai
Tel: 86-21-5407-5533
Fax: 86-21-5407-5066

China - Shenyang
Tel: 86-24-2334-2829
Fax: 86-24-2334-2393

China - Shenzhen
Tel: 86-755-8203-2660
Fax: 86-755-8203-1760

China - Shunde
Tel: 86-757-2839-5507
Fax: 86-757-2839-5571

China - Qingdao
Tel: 86-532-502-7355
Fax: 86-532-502-7205

ASIA/PACIFIC

India - Bangalore
Tel: 91-80-2229-0061
Fax: 91-80-2229-0062

India - New Delhi
Tel: 91-11-5160-8631
Fax: 91-11-5160-8632

Japan - Kanagawa
Tel: 81-45-471- 6166
Fax: 81-45-471-6122

Korea - Seoul
Tel: 82-2-554-7200
Fax: 82-2-558-5932 or
82-2-558-5934

Malaysia - Penang
Tel: 011-604-646-8870
Fax: 011-604-646-5086

Philippines - Manila
Tel: 011-632-634-9065
Fax: 011-632-634-9069

Singapore
Tel: 65-6334-8870
Fax: 65-6334-8850

Taiwan - Kaohsiung
Tel: 886-7-536-4818
Fax: 886-7-536-4803

Taiwan - Taipei
Tel: 886-2-2500-6610
Fax: 886-2-2508-0102

Taiwan - Hsinchu
Tel: 886-3-572-9526
Fax: 886-3-572-6459

EUROPE

Austria - Weis
Tel: 43-7242-2244-399
Fax: 43-7242-2244-393

Denmark - Ballerup
Tel: 45-4450-2828
Fax: 45-4485-2829

France - Massy
Tel: 33-1-69-53-63-20
Fax: 33-1-69-30-90-79

Germany - Ismaning
Tel: 49-89-627-144-0
Fax: 49-89-627-144-44

Italy - Milan
Tel: 39-0331-742611
Fax: 39-0331-466781

Netherlands - Drunen
Tel: 31-416-690399
Fax: 31-416-690340

England - Berkshire
Tel: 44-118-921-5869
Fax: 44-118-921-5820

Компания «Океан Электроники» предлагает заключение долгосрочных отношений при поставках импортных электронных компонентов на взаимовыгодных условиях!

Наши преимущества:

- Поставка оригинальных импортных электронных компонентов напрямую с производств Америки, Европы и Азии, а так же с крупнейших складов мира;
- Широкая линейка поставок активных и пассивных импортных электронных компонентов (более 30 млн. наименований);
- Поставка сложных, дефицитных, либо снятых с производства позиций;
- Оперативные сроки поставки под заказ (от 5 рабочих дней);
- Экспресс доставка в любую точку России;
- Помощь Конструкторского Отдела и консультации квалифицированных инженеров;
- Техническая поддержка проекта, помощь в подборе аналогов, поставка прототипов;
- Поставка электронных компонентов под контролем ВП;
- Система менеджмента качества сертифицирована по Международному стандарту ISO 9001;
- При необходимости вся продукция военного и аэрокосмического назначения проходит испытания и сертификацию в лаборатории (по согласованию с заказчиком);
- Поставка специализированных компонентов военного и аэрокосмического уровня качества (Xilinx, Altera, Analog Devices, Intersil, Interpoint, Microsemi, Actel, Aeroflex, Peregrine, VPT, Syfer, Eurofarad, Texas Instruments, MS Kennedy, Miteq, Cobham, E2V, MA-COM, Hittite, Mini-Circuits, General Dynamics и др.);

Компания «Океан Электроники» является официальным дистрибьютором и эксклюзивным представителем в России одного из крупнейших производителей разъемов военного и аэрокосмического назначения «JONHON», а так же официальным дистрибьютором и эксклюзивным представителем в России производителя высокотехнологичных и надежных решений для передачи СВЧ сигналов «FORSTAR».



JONHON

«JONHON» (основан в 1970 г.)

Разъемы специального, военного и аэрокосмического назначения:

(Применяются в военной, авиационной, аэрокосмической, морской, железнодорожной, горно- и нефтедобывающей отраслях промышленности)

«FORSTAR» (основан в 1998 г.)

ВЧ соединители, коаксиальные кабели,
кабельные сборки и микроволновые компоненты:

(Применяются в телекоммуникациях гражданского и специального назначения, в средствах связи, РЛС, а так же военной, авиационной и аэрокосмической отраслях промышленности).



Телефон: 8 (812) 309-75-97 (многоканальный)

Факс: 8 (812) 320-03-32

Электронная почта: ocean@oceanchips.ru

Web: <http://oceanchips.ru/>

Адрес: 198099, г. Санкт-Петербург, ул. Калинина, д. 2, корп. 4, лит. А