

Single-channel HOTLink II™ Transceiver

Features

- Second-generation HOTLink® technology
- Compliant to multiple standards
 - ESCON®, DVB-ASI, fibre channel and gigabit ethernet (IEEE802.3z)
 - CPRI™ compliant
 - CYV15G0101DXB compliant to SMPTE 259M and SMPTE 292M
 - 8B/10B encoded or 10-bit unencoded data
- Single-channel transceiver operates from 195 to 1500 MBaud serial data rate
- Selectable parity check/generate
- Selectable input clocking options
- Selectable output clocking options
- MultiFrame™ Receive Framer
 - Bit and byte alignment
 - Comma or full K28.5 detect
 - Single- or multi-byte framer for byte alignment
 - Low-latency option
- Synchronous LVTTTL parallel input and parallel output interface
- Internal phase-locked loops (PLLs) with no external PLL components
- Dual differential PECL-compatible serial inputs
 - Internal DC-restoration
- Dual differential PECL-compatible serial outputs
 - Source matched for driving 50 Ω transmission lines
 - No external bias resistors required
 - Signaling-rate controlled edge-rates
- Optional elasticity buffer in receive path
- Optional phase align buffer in transmit path

- Compatible with
 - Fiber-optic modules
 - Copper cables
 - Circuit board traces
- JTAG boundary scan
- Built-in self-test (BIST) for at-speed link testing
- Per-channel link quality indicator
 - Analog signal detect
 - Digital signal detect
- Low power 1.25 W at 3.3 V typical
- Single 3.3 V supply
- 100-ball BGA
- Pb-free package option available
- 0.25 μ BiCMOS technology

Functional Description

The CYP15G0101DXB^[1] single-channel HOTLink II™ transceiver is a point-to-point communications building block allowing the transfer of data over a high-speed serial link (optical fiber, balanced, and unbalanced copper transmission lines) at signaling speeds ranging from 195 to 1500 MBaud.

The transmit channel accepts parallel characters in an input register, encodes each character for transport, and converts it to serial data. The receive channel accepts serial data and converts it to parallel data, frames the data to character boundaries, decodes the framed characters into data and special characters, and presents these characters to an output register. Figure 1 illustrates typical connections between independent host systems and corresponding CYP(V)15G0101DXB parts. As a second-generation HOTLink device, the CYP(V)15G0101DXB extends the HOTLink II family with enhanced levels of integration and faster data rates, while maintaining serial-link compatibility (data, command, and BIST) with other HOTLink devices.

Figure 1. HOTLink II System Connections

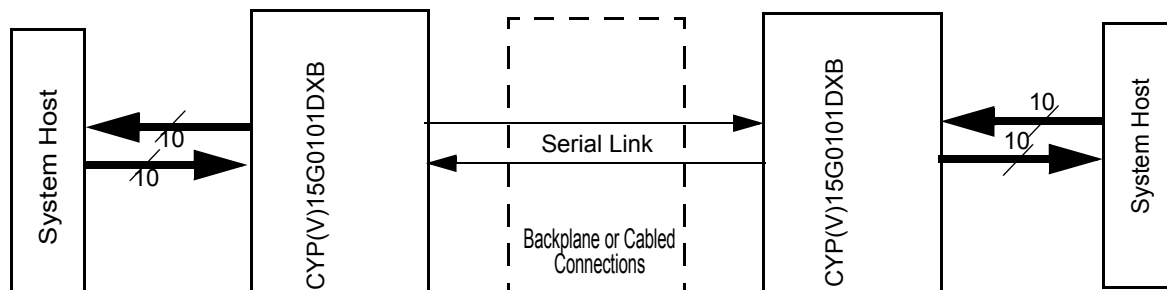

Note

1. CYV15G0101DXB refers to SMPTE 259M and SMPTE 292M compliant devices. CYP15G0101DXB refers to devices not compliant to SMPTE 259M and SMPTE 292M pathological test requirements. CYP(V)15G0101DXB refers both devices.

The CYV15G0101DXB satisfies the SMPTE 259M and SMPTE 292M compliance as per the EG34-1999 pathological test requirements. The transmit (TX) section of the CYP(V)15G0101DXB single-channel HOTLink II consists of a byte-wide channel. The channel can accept either eight-bit data characters or pre-encoded 10-bit transmission characters. Data characters are passed from the transmit input register to an embedded 8B/10B encoder to improve their serial transmission characteristics. These encoded characters are then serialized and output from dual positive ECL (PECL)-compatible differential transmission-line drivers at a bit-rate of either 10 or 20 times the input reference clock.

The receive (RX) section of the CYP(V)15G0101DXB single-channel HOTLink II consists of a byte-wide channel. The channel accepts a serial bit-stream from one of two PECL-compatible differential line receivers and, using a completely integrated PLL clock synchronizer, recovers the timing information necessary for data reconstruction. The recovered bit-stream is deserialized and framed into characters, 8B/10B decoded, and checked for transmission errors. Recovered decoded characters are then written to an internal elasticity buffer, and presented to the destination host system. The integrated 8B/10B encoder/decoder may be bypassed for systems that present externally encoded or scrambled data at the parallel interface.

The parallel I/O interface may be configured for numerous forms of clocking to provide the highest flexibility in system architecture. In addition to clocking the transmit path interfaces from one or multiple sources, the receive interface may be configured to present data relative to a recovered clock or to a local reference clock.

The transmit and the receive channels contain BIST pattern generators and checkers, respectively. This BIST hardware allows at-speed testing of the high-speed serial data paths in both transmit and receive sections, as well as across the interconnecting links.

HOTLink II devices are ideal for a variety of applications where parallel interfaces can be replaced with high-speed, point-to-point serial links. Some applications include interconnecting backplanes on switches, routers, base-stations, servers and video transmission systems.

The CYV15G0101DXB is verified by testing to be compliant to all the pathological test patterns documented in SMPTE EG34-1999, for both the SMPTE 259M and 292M signaling rates. The tests ensure that the receiver recovers data with no errors for the following patterns:

1. Repetitions of 20 ones and 20 zeros.
2. Single burst of 44 ones or 44 zeros.
3. Repetitions of 19 ones followed by 1 zero or 19 zeros followed by 1 one.

Transceiver Logic Block Diagram

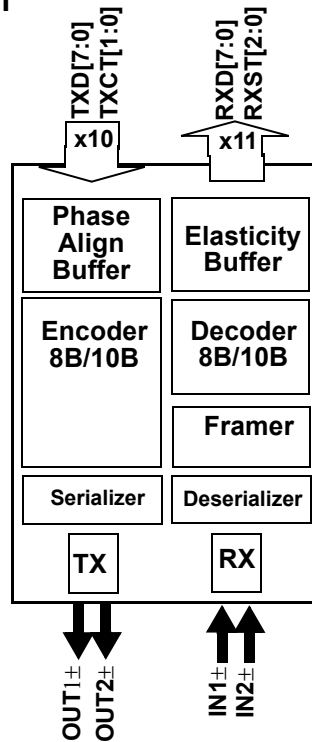

Logic Block Diagram

-- ▷ = Internal Signal

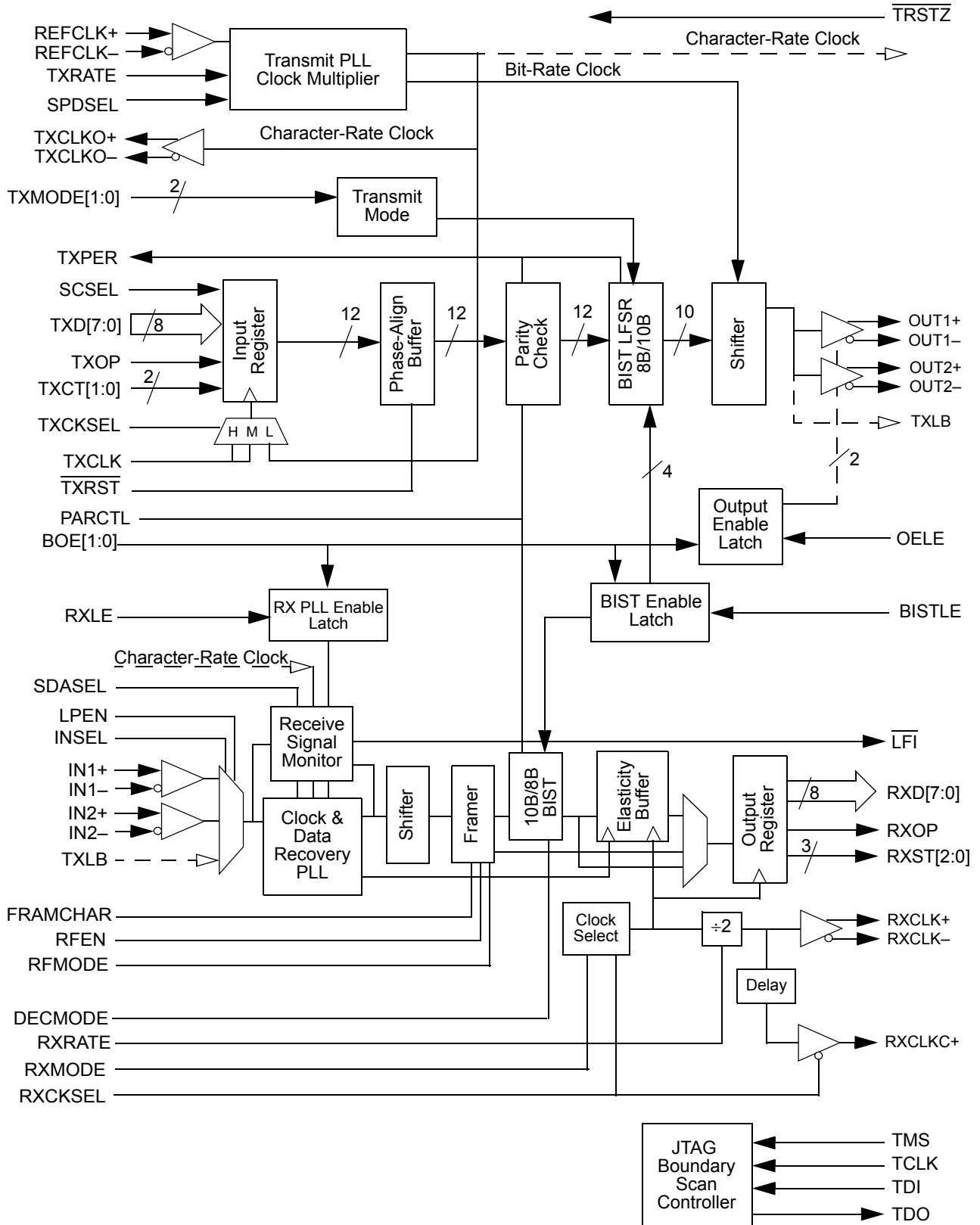

Contents

| | | | |
|--|-----------|--|-----------|
| Pin Configurations | 5 | CYP(V)15G0101DXB AC Characteristics | 27 |
| Pin Descriptions | 6 | Switching Waveforms for | |
| CYP(V)15G0101DXB HOTLink II Operation | 12 | the HOTLink II Transmitter | 29 |
| CYP(V)15G0101DXB Transmit Data Path | 12 | X3.230 Codes and Notation Conventions | 33 |
| Transmit Modes | 13 | Notation Conventions | 33 |
| Transmit BIST | 15 | 8B/10B Transmission Code | 33 |
| Serial Output Drivers | 16 | Transmission Order | 33 |
| Transmit PLL Clock Multiplier | 16 | Valid and Invalid Transmission Characters | 33 |
| CYP(V)15G0101DXB Receive Data Path | 16 | Use of the Tables for Generating | |
| Serial Line Receivers | 16 | Transmission Characters | 34 |
| Signal Detect/Link Fault | 17 | Use of the Tables for Checking | |
| Clock/Data Recovery | 18 | the Validity of Received Transmission Characters | 34 |
| Deserializer/Framer | 18 | Ordering Information | 40 |
| 10B/8B Decoder Block | 19 | Ordering Code Definitions | 40 |
| Receive BIST Operation | 19 | Package Diagram | 41 |
| Receive Elasticity Buffer | 20 | Acronyms | 42 |
| Receive Modes | 20 | Document Conventions | 42 |
| Power Control | 20 | Units of Measure | 42 |
| Output Bus | 21 | Document History Page | 43 |
| Parity Generation | 22 | Sales, Solutions, and Legal Information | 45 |
| JTAG Support | 23 | Worldwide Sales and Design Support | 45 |
| Maximum Ratings | 25 | Products | 45 |
| Power-up Requirements | 25 | PSoC® Solutions | 45 |
| DC Electrical Characteristics | 25 | Cypress Developer Community | 45 |
| AC Test Loads and Waveforms | 26 | Technical Support | 45 |

Pin Configurations

Top View

| | 1 | 2 | 3 | 4 | 5 | 6 | 7 | 8 | 9 | 10 |
|---|-----------------|---------|-----------------|---------|---------|-----------|--------|--------------------|--------------------|--------------------|
| A | V _{CC} | IN2+ | V _{CC} | OUT2- | RXMODE | TXMODE[1] | IN1+ | V _{CC} | OUT1- | V _{CC} |
| B | V _{CC} | IN2- | TDO | OUT2+ | TXRATE | TXMODE[0] | IN1- | #NC ^[2] | OUT1+ | V _{CC} |
| C | RFEN | LPEN | RXLE | RXCLKC+ | RXRATE | SDASEL | SPDSEL | PARCTL | RFMODE | INSEL |
| D | BOE[0] | BOE[1] | FRAMCHAR | GND | GND | GND | GND | TMS | TRSTZ | TDI |
| E | BISTLE | DECMODE | OELE | GND | GND | GND | GND | TCLK | RXCKSEL | TXCKSEL |
| F | RXST[2] | RXST[1] | RXST[0] | GND | GND | GND | GND | TXPER | REFCLK- | REFCLK+ |
| G | RXOP | RXD[1] | RXD[5] | GND | GND | GND | GND | TXOP | TXCLKO+ | TXCLKO- |
| H | RXD[0] | RXD[2] | RXD[6] | LFI | TXCT[1] | TXD[6] | TXD[3] | TXCLK | TXRST | #NC ^[2] |
| J | V _{CC} | RXD[3] | RXD[7] | RXCLK- | TXCT[0] | TXD[5] | TXD[2] | TXD[0] | #NC ^[2] | V _{CC} |
| K | V _{CC} | RXD[4] | V _{CC} | RXCLK+ | TXD[7] | TXD[4] | TXD[1] | V _{CC} | SCSEL | V _{CC} |

Bottom View

| | 10 | 9 | 8 | 7 | 6 | 5 | 4 | 3 | 2 | 1 | |
|--------------------|--------------------|--------------------|--------|-----------|---------|---------|-----------------|---------|-----------------|---|---|
| V _{CC} | OUT1- | V _{CC} | IN1+ | TXMODE[1] | RXMODE | OUT2- | V _{CC} | IN2+ | V _{CC} | | A |
| V _{CC} | OUT1+ | #NC ^[2] | IN1- | TXMODE[0] | TXRATE | OUT2+ | TDO | IN2- | V _{CC} | | B |
| INSEL | RFMODE | PARCTL | SPDSEL | SDASEL | RXRATE | RXCLKC+ | RXLE | LPEN | RFEN | | C |
| TDI | TRSTZ | TMS | GND | GND | GND | GND | FRAMCHAR | BOE[1] | BOE[0] | | D |
| TXCKSEL | RXCKSEL | TCLK | GND | GND | GND | GND | OELE | DECMODE | BISTLE | | E |
| REFCLK+ | REFCLK- | TXPER | GND | GND | GND | GND | RXST[0] | RXST[1] | RXST[2] | | F |
| TXCLKO- | TXCLKO+ | TXOP | GND | GND | GND | GND | RXD[5] | RXD[1] | RXOP | | G |
| #NC ^[2] | TXRST | TXCLK | TXD[3] | TXD[6] | TXCT[1] | LFI | RXD[6] | RXD[2] | RXD[0] | | H |
| V _{CC} | #NC ^[2] | TXD[0] | TXD[2] | TXD[5] | TXCT[0] | RXCLK- | RXD[7] | RXD[3] | V _{CC} | | J |
| V _{CC} | SCSEL | V _{CC} | TXD[1] | TXD[4] | TXD[7] | RXCLK+ | V _{CC} | RXD[4] | V _{CC} | | K |

Note

2. #NC = Do Not Connect.

Pin Descriptions

CYP(V)15G0101DXB single-channel HOTLink II

| Pin Name | I/O Characteristics | Signal Description |
|-----------------------------------|---|---|
| Transmit Path Data Signals | | |
| TXPER | LVTTL output, changes relative to REFCLK↑ ^[3] | <p>Transmit path parity error. Active HIGH. Asserted (HIGH) if parity checking is enabled (PARCTL ≠ LOW) and a parity error is detected at the encoder. This output is HIGH for one transmit character-clock period to indicate detection of a parity error in the character presented to the encoder.</p> <p>If a parity error is detected, the character in error is replaced with a C0.7 character to force a corresponding bad-character detection at the remote end of the link. This replacement takes place regardless of the encoded/un-encoded state of the interface.</p> <p>When BIST is enabled for the specific transmit channel, BIST progress is presented on this output. Once every 511 character times (plus a 16-character Word Sync Sequence when the receive channel is clocked by REFCLK, i.e., RXCKSEL = LOW), the TXPER signal pulses HIGH for one transmit-character clock period (if RXCKSEL = MID) or seventeen transmit-character clock periods (if RXCKSEL = LOW or HIGH) to indicate a complete pass through the BIST sequence. For RXCKSEL = LOW or HIGH, If TXMODE[1:0] = LL, then no Word Sync Sequence is sent in BIST, and TXPER pulses HIGH for one transmit-character clock period.</p> <p>This output also provides an indication of a phase-align buffer underflow/overflow condition. When the phase-align buffer is enabled (TXCKSEL ≠ LOW, or TXCKSEL = LOW and TXRATE = HIGH), and an underflow/overflow condition is detected, TXPER is asserted and remains asserted until either an atomic Word Sync Sequence is transmitted or TXRST is sampled LOW to recenter the phase-align buffer.</p> |
| TXCT[1:0] | LVTTL input, synchronous, sampled by TXCLK↑ or REFCLK↑ ^[3] | <p>Transmit control. These inputs are captured on the rising edge of the transmit interface clock as selected by TXCKSEL, and are passed to the encoder or transmit shifter. They identify how the TXD[7:0] characters are interpreted. When the encoder is enabled, these inputs determine if the TXD[7:0] character is encoded as data, a special character code, a K28.5 fill character or a Word Sync Sequence. When the encoder is bypassed, these inputs are interpreted as data bits. See Table 1 for details.</p> |
| TXD[7:0] | LVTTL input, synchronous, sampled by TXCLK↑ or REFCLK↑ ^[3] | <p>Transmit data inputs. These inputs are captured on the rising edge of the transmit interface clock as selected by TXCKSEL, and passed to the encoder or transmit shifter.</p> <p>When the encoder is enabled (TXMODE[1] ≠ LOW), TXD[7:0] specify the specific data or command character to be sent. When the encoder is bypassed, these inputs are interpreted as data bits of the 10-bit input character. See Table 1 for details.</p> |
| TXOP | LVTTL input, synchronous, internal pull-up, sampled by TXCLK↑ or REFCLK↑ ^[3] | <p>Transmit path odd parity. When parity checking is enabled (PARCTL ≠ LOW), the parity captured at this input is XORed with the data on the TXD bus (and sometimes TXCT[1:0]) to verify the integrity of the captured character. See Table 2 for details.</p> |
| SCSEL | LVTTL input, synchronous, internal pull-down, sampled by TXCLK↑ or REFCLK↑ ^[3] | <p>Special character select. Used in some transmit modes along with TXCTx[1:0] to encode special characters or to initiate a Word Sync Sequence. When the transmit path is configured to select TXCLK to clock the input register (TXCKSEL = MID or HIGH), SCSEL is captured relative to TXCLK↑.</p> |

Note

- When REFCLK is configured for half-rate operation (TXRATE = HIGH), this input is sampled (or the outputs change) relative to both the rising and falling edges of REFCLK.

Pin Descriptions (continued)

CYP(V)15G0101DXB single-channel HOTLink II

| Pin Name | I/O Characteristics | Signal Description |
|--|--|--|
| TXRST | LVTTL input, asynchronous, internal pull-up, sampled by REFCLK↑ ^[4] | <p>Transmit clock phase reset. Active LOW. When sampled LOW, the transmit phase-align buffer is allowed to adjust its data-transfer timing (relative to the selected input clock) to allow clean transfer of data from the input register to the encoder or transmit shifter. When TXRST is sampled HIGH, the internal phase relationship between the TXCLK and the internal character-rate clock is fixed and the device operates normally.</p> <p>When configured for half-rate REFCLK sampling of the transmit character stream (TXCKSEL = LOW and TXRATE = HIGH), assertion of TXRST is only used to clear phase-align buffer faults caused by highly asymmetric reference clock periods or reference clocks with excessive cycle-to-cycle jitter. During this alignment period, one or more characters may be added to or lost from all the associated transmit paths as the transmit phase-align buffers are adjusted. TXRST must be sampled LOW by a minimum of two consecutive rising edges of REFCLK to ensure the reset operation is initiated correctly on all channels. This input is ignored when both TXCKSEL and TXRATE are LOW, since the phase align buffer is bypassed. In all other configurations, TXRST should be asserted during device initialization to ensure proper operation of the phase-align buffer. TXRST should be asserted after the assertion and deassertion of TRSTZ, after the presence of a valid TXCLK and after allowing enough time for the TXPLL to lock to the reference clock (as specified by parameter t_{TXLOCK}).</p> |
| Transmit Path Clock and Clock Control | | |
| TXCKSEL | 3-level select static control input ^[5] | <p>Transmit clock select. Selects the clock source used to write data into the transmit input register of the transmit channel. When LOW, the input register is clocked by REFCLK↑.^[4] When HIGH or MID, TXCLK↑ is the input register clock for TXD[7:0] and TXCT[1:0].</p> <p>When TXRATE=HIGH, configuring TXCKSEL = HIGH or MID is an invalid mode of operation.</p> |
| TXCLKO± | LVTTL output | <p>Transmit clock output. This true and complement output clock is synthesized by the transmit PLL and is synchronous to the internal transmit character clock. It has the same frequency as REFCLK (when TXRATE = LOW), or twice the frequency of REFCLK (when TXRATE = HIGH). This output clock has no direct phase relationship to REFCLK.</p> |
| TXRATE | LVTTL input, static control input, internal pull-down | <p>Transmit PLL clock rate select. When TXRATE = HIGH, the transmit PLL multiplies REFCLK by 20 to generate the serial bit-rate clock.</p> <p>When TXRATE = LOW, the transmit PLL multiplies REFCLK by 10 to generate the serial bit-rate clock. See Table 9 for a list of operating serial rates.</p> <p>When REFCLK is selected to clock the receive parallel interfaces (RXCKSEL = LOW), the TXRATE input also determines if the clocks on the RXCLK± and RXCLKC+ outputs are full or half-rate. When TXRATE = HIGH (REFCLK is half-rate), the RXCLK± and RXCLKC+ output clocks are also half-rate clocks and follow the frequency and duty cycle of the REFCLK input. When TXRATE = LOW (REFCLK is full-rate), the RXCLK± and RXCLKC+ output clocks are also full-rate clocks and follow the frequency and duty cycle of the REFCLK input.</p> <p>When TXRATE=HIGH, configuring TXCKSEL = HIGH or MID is an invalid mode of operation.</p> |
| TXCLK | LVTTL clock input, internal pull-down | <p>Transmit path input clock. This clock must be frequency-coherent to TXCLKO±, but may be offset in phase. The internal operating phase of the input clock (relative to REFCLK or TXCLKO+) is adjusted when TXRST = LOW and locked when TXRST = HIGH.</p> |
| Transmit Path Mode Control | | |
| TXMODE[1:0] | 3-level select ^[5] static control inputs | <p>Transmit operating mode. These inputs are interpreted to select one of nine operating modes of the transmit path. See Table 3 for a list of operating modes.</p> |

Notes

- When REFCLK is configured for half-rate operation (TXRATE = HIGH), this input is sampled (or the outputs change) relative to both the rising and falling edges of REFCLK.
- 3-level select inputs are used for static configuration. They are ternary (not binary) inputs that make use of non-standard logic levels of LOW, MID, and HIGH. The LOW level is usually implemented by direct connection to V_{SS} (ground). The HIGH level is usually implemented by direct connection to V_{CC} (power). When not connected or allowed to float, a 3-level select input will self-bias to the MID level.

Pin Descriptions *(continued)*

CYP(V)15G0101DXB single-channel HOTLink II

| Pin Name | I/O Characteristics | Signal Description |
|---|---|--|
| Receive Path Data Signals | | |
| RXD[7:0] | LVTTTL output, synchronous to the RXCLK \uparrow output (or REFCLK \uparrow input ^[6]) when RXCKSEL = LOW) | <p>Parallel data output. These outputs change following the rising edge of the selected receive interface clock.</p> <p>When the decoder is enabled (DECMODE = HIGH or MID), these outputs represent either received data or a special character. The status of the received data is represented by the values of RXST[2:0].</p> <p>When the decoder is bypassed (DECMODE = LOW), RXD[7:0] become the higher order bits of the 10-bit received character. See Table 13 for details.</p> |
| RXST[2:0] | LVTTTL output, synchronous to the RXCLK \uparrow output (or REFCLK \uparrow input ^[6]) when RXCKSEL = LOW) | <p>Parallel status output. These outputs change following the rising edge of the selected receive interface clock.</p> <p>When the decoder is bypassed (DECMODE = LOW), RXST[1:0] become the two low-order bits of the 10-bit received character, while RXST[2] = HIGH indicates the presence of a comma character in the output register.</p> <p>When the decoder is enabled (DECMODE = HIGH or MID), RXST[2:0] provide status of the received signal. See Table 16 for a list of receive character status.</p> |
| RXOP | 3-state, LVTTTL output, synchronous to the RXCLK \uparrow output (or REFCLK \uparrow input ^[6]) when RXCKSEL = LOW) | <p>Receive path odd parity. When parity generation is enabled (PARCTL \neq LOW), the parity output is valid for the data on the RXD bus bits.</p> <p>When parity generation is disabled (PARCTL = LOW), this output driver is disabled (high Z).</p> |
| Receive Path Clock and Clock Control | | |
| RXCLK \pm | 3-state, LVTTTL output clock | <p>Receive character clock output. When configured such that the output data path is clocked by the recovered clock (RXCKSEL = MID), these true and complement clocks are the receive interface clocks which are used to control timing of output data (RXD[7:0], RXST[2:0] and RXOP). This clock is output continuously at either the dual-character rate (1/20th the serial bit-rate) or character rate (1/10th the serial bit-rate) of the data being received, as selected by RXRATE.</p> <p>When configured such that the output data path is clocked by REFCLK instead of recovered clock (RXCKSEL = LOW), the RXCLK\pm output drivers present a buffered and delayed form of REFCLK. In this mode, RXCLK\pm and RXCLKC+ are buffered forms of REFCLK that are slightly different in phase, but follow the frequency and duty cycle of REFCLK. This phase difference allows the user to select the optimal set-up/hold timing for their specific interface.</p> |
| RXCLKC+ | 3-state, LVTTTL output | <p>Delayed REFCLK+ when RXCKSEL = LOW. Delayed form of REFCLK+, used for transfer of output data to a host system. This output is only enabled when the receive parallel interface is configured to present data relative to REFCLK (RXCKSEL = LOW). When RXCKSEL = LOW, the RXCLKC+ follows the frequency and duty cycle of REFCLK+.</p> |
| RXRATE | LVTTTL input static control input, internal pull-down | <p>Receive clock rate select. When LOW, the RXCLK\pm recovered clock outputs are complementary clocks operating at the recovered character rate. Data for the receive channel should be latched on either the rising edge of RXCLK+ or falling edge of RXCLK-.</p> <p>When HIGH, the RXCLK\pm recovered clock outputs are complementary clocks operating at half the character rate. Data for the receive channel should be latched alternately on the rising edge of RXCLK+ and RXCLK-.</p> <p>When the output register is operated with REFCLK clocking (RXCKSEL = LOW), RXRATE is not interpreted and RXCLK\pm follows the frequency and duty cycle of REFCLK.</p> |
| RFEN | LVTTTL input, asynchronous, internal pull-down | <p>Reframe enable. Active HIGH. When HIGH, the Framer in the receive channel is enabled to frame per the presently enabled framing mode and selected framing character.</p> |

Note

6. When REFCLK is configured for half-rate operation (TXRATE = HIGH), this input is sampled (or the outputs change) relative to both the rising and falling edges of REFCLK.

Pin Descriptions (continued)

CYP(V)15G0101DXB single-channel HOTLink II

| Pin Name | I/O Characteristics | Signal Description |
|----------|---|---|
| RXMODE | 3-level select ^[7] static control input | Receive operating mode. This input selects one of two RXST channel status reporting modes and is only interpreted when the decoder is enabled (DECMODE ≠ LOW). See Table 19 for details. |
| FRAMCHAR | 3-level select ^[7] static control input | Framing character select. Used to select the character or portion of a character used for character framing of the received data streams. When MID, the framer looks for both positive and negative disparity versions of the eight-bit comma character. When HIGH, the framer looks for both positive and negative disparity versions of the K28.5 character. Configuring FRAMCHAR = LOW is reserved for component test. |
| RFMODE | 3-level select static control input ^[7] | Reframe mode select. Used to select the type of character framing used to adjust the character boundaries (based on detection of one or more framing characters in the data stream. This signal operates in conjunction with the type of framing character selected. When LOW, the low-latency framer is selected. This will frame on each occurrence of the selected framing character(s) in the received data stream. This mode of framing stretches the recovered character-rate clock for one or multiple cycles to align that clock with the recovered data. When MID, the Cypress-mode multi-byte parallel framer is selected. This requires a pair of the selected framing character(s), on identical 10-bit boundaries, within a span of 50 bits (five characters), before the character boundaries are adjusted. The recovered character clock remains in the same phase regardless of character offset. When HIGH, the alternate-mode multi-byte parallel framer is selected. This requires detection of the selected framing character(s) in the received data stream, on identical 10-bit boundaries, on four directly adjacent characters. The recovered character clock remains in the same phase regardless of character offset. |
| PARCTL | 3-level select static control input ^[7] | Parity check/Generate control. Used to control the parity check and generate functions. When LOW, parity checking is disabled, and the RXOP output is disabled (high Z). When MID, and the 8B/10B encoder and decoder are enabled (TXMODE[1] ≠ LOW, DECMODE ≠ LOW), TXD[7:0] inputs are checked (along with TXOP) for valid ODD parity, and ODD parity is generated for the RXD[7:0] outputs and presented on RXOP. When the 8B/10B encoder and decoder are disabled (TXMODE[1] = LOW, DECMODE = LOW), the TXD[7:0] and TXCT[1:0] inputs are checked (along with TXOP) for valid ODD parity, and ODD parity is generated for the RXD[7:0] and RXST[1:0] outputs and presented on RXOP. When HIGH, parity generation and checking are enabled. The TXD[7:0] and TXCT[1:0] inputs are checked (along with TXOP) for valid ODD parity, and ODD parity is generated for the RXD[7:0] and RXST[2:0] outputs and presented on RXOP. See Table 2 and Table 15 for details. |
| DECMODE | 3-level select static control input ^[7] | Decoder mode select. When LOW, the decoder is bypassed and raw 10-bit characters are passed to the output register. When the decoder is bypassed, RXCKSEL must be MID. When MID, the Cypress Decoder table for special code characters is used. When HIGH, the alternate Decoder table for special code characters is used. See Table 21 for a list of the special codes supported in both encoded modes. |
| RXCKSEL | 3-level select ^[7] static control input | Receive clock mode. Selects the receive clock source used to transfer data to the output registers and configures the elasticity buffer in the receive path. When LOW, the output register is clocked by REFCLK. RXCLK± and RXCLKC+ present buffered and delayed forms of REFCLK. When MID, the RXCLK± output follows the recovered clock as selected by RXRATE and the elasticity buffer is bypassed. When the 10B/8B decoder and elasticity buffer are bypassed (DECMODE=LOW), RXCKSEL must be MID. Configuring RXCKSEL = HIGH is an invalid mode of operation. |

Note

7. 3-level select inputs are used for static configuration. They are ternary (not binary) inputs that make use of non-standard logic levels of LOW, MID, and HIGH. The LOW level is usually implemented by direct connection to V_{SS} (ground). The HIGH level is usually implemented by direct connection to V_{CC} (power). When not connected or allowed to float, a 3-level select input will self-bias to the MID level.

Pin Descriptions (continued)

CYP(V)15G0101DXB single-channel HOTLink II

| Pin Name | I/O Characteristics | Signal Description |
|-------------------------------|---|---|
| Device Control Signals | | |
| SPDSEL | 3-level select, ^[8] static control input | Serial rate select. This input specifies the operating bit-rate range of both transmit and receive PLLs. LOW = 195–400 MBaud, MID = 400–800 MBaud, HIGH = 800–1500 MBaud. When SPDSEL=LOW, setting TXRATE=HIGH (half-rate reference clock) is invalid. |
| REFCLK± | Differential LVPECL or single-ended LVTTTL input clock | Reference clock. This clock input is used as the timing reference for the transmit PLL. It is also used as the centering frequency of the range controller block of the receive CDR PLLs. This input clock may also be selected to clock the transmit and receive parallel interfaces. When driven by a single-ended LVCMOS or LVTTTL clock source, the clock source may be connected to either the true or complement REFCLK input, with the alternate REFCLK input left open (floating). When driven by an LVPECL clock source, the clock must be a differential clock, using both inputs. When TXCKSEL = LOW, REFCLK is also used as the clock for the parallel transmit data (input) interface. When RXCKSEL = LOW and decoder is enabled, the elasticity buffer is enabled and REFCLK is used as the clock source for the parallel receive data (output) interface. If the elasticity buffer is used, framing characters will be inserted or deleted to/from the data stream to compensate for frequency differences between the reference clock and recovered clock. When addition happens, a K28.5 will be appended immediately after a framing character is detected in the elasticity buffer. When deletion happens, a framing character will be removed from the data stream when detected in the elasticity buffer. |
| TRSTZ | LVTTTL input, internal pull-up | Device reset. Active LOW. Initializes all state machines and counters in the device. When sampled LOW by the rising edge of REFCLK, this input resets the internal state machines and sets the elasticity buffer pointers to a nominal offset. When the reset is removed (TRSTZ sampled HIGH by REFCLK↑), the status and data outputs will become deterministic in less than 16 REFCLK cycles. The BISTLE, OELE, and RXLE latches are reset by TRSTZ. If the elasticity buffer or the phase-align buffer are used, TRSTZ should be applied after power-up to initialize the internal pointers into these memory arrays. |
| Analog I/O and Control | | |
| OUT1± | CML differential output | Primary differential serial data outputs. These PECL-compatible CML outputs (+3.3 V referenced) are capable of driving terminated transmission lines or standard fiber-optic transmitter modules. |
| OUT2± | CML differential output | Secondary differential serial data outputs. These PECL-compatible CML outputs (+3.3 V referenced) are capable of driving terminated transmission lines or standard fiber-optic transmitter modules. |
| IN1± | LVPECL differential Input, with internal DC restoration | Primary differential serial data inputs. These inputs accept the serial data stream for deserialization and decoding. The IN1± serial stream is passed to the receiver clock and data recovery (CDR) circuit to extract the data content when INSEL = HIGH. |
| IN2± | LVPECL differential input, with internal DC restoration | Secondary differential serial data inputs. These inputs accept the serial data stream for deserialization and decoding. The IN2± serial stream is passed to the receiver CDR circuit to extract the data content when INSEL = LOW. |
| INSEL | LVTTTL input, asynchronous | Receive input selector. Determines which external serial bit stream is passed to the receiver CDR. When HIGH, the IN1± input is selected. When LOW, the IN2± input is selected. |
| SDASEL | 3-level select, ^[8] static control input | Signal detect amplitude level select. Allows selection of one of three predefined amplitude trip points for a valid signal indication, as listed in Table 10. |
| LPEN | LVTTTL input, asynchronous, internal pull-down | Loop-back-enable. Active HIGH. When asserted (HIGH), the transmit serial data is internally routed to the receiver CDR circuit. All enabled serial drivers are forced to differential logic “1.” All serial data inputs are ignored. |

8. 3-level select inputs are used for static configuration. They are ternary (not binary) inputs that make use of non-standard logic levels of LOW, MID, and HIGH. The LOW level is usually implemented by direct connection to V_{SS} (ground). The HIGH level is usually implemented by direct connection to V_{CC} (power). When not connected or allowed to float, a 3-level select input will self-bias to the MID level.

Pin Descriptions (continued)

CYP(V)15G0101DXB single-channel HOTLink II

| Pin Name | I/O Characteristics | Signal Description |
|-----------------------|---|---|
| OELE | LVTTL input, asynchronous, internal pull-up | Serial driver output enable latch enable. Active HIGH. When OELE = HIGH, the signals on the BOE[1:0] inputs directly control the OUT _{x±} differential drivers. When the BOE[x] input is HIGH, the associated OUT _{x±} differential driver is enabled. When the BOE[x] input is LOW, the associated OUT _{x±} differential driver is powered down. When OELE returns LOW, the last values present on BOE[1:0] are captured in the internal output enable latch. The specific mapping of BOE[1:0] signals to transmit output enables is listed in Table 14. If the device is reset (TRSTZ is sampled LOW), the latch is reset to disable both outputs. |
| BISTLE | LVTTL input, asynchronous, internal pull-up | Transmit and receive BIST latch enable. Active HIGH. When BISTLE = HIGH, the signals on the BOE[1:0] inputs directly control the transmit and receive BIST enables. When the BOE[x] input is LOW, the associated transmit or receive channel is configured to generate or compare the BIST sequence. When the BOE[x] input is HIGH, the associated transmit or receive channel is configured for normal data transmission or reception. When BISTLE returns LOW, the last values present on BOE[1:0] are captured in the internal BIST enable latch. The specific mapping of BOE[1:0] signals to transmit and receive BIST enables is listed in Table 14. When the latch is closed, if the device is reset (TRSTZ is sampled LOW), the latch is reset to disable BIST on both the transmit and receive channels. |
| RXLE | LVTTL input, asynchronous, internal pull-up | Receive channel power-control latch enable. Active HIGH. When RXLE = HIGH, the signal on the BOE[0] input directly controls the power enable for the receive PLL and analog logic. When the BOE[0] input is HIGH, the receive channel PLL and analog logic are active. When the BOE[0] input is LOW, the receive channel PLL and analog logic are placed in a non-functional power saving mode. When RXLE returns LOW, the last value present on BOE[0] is captured in the internal RX PLL enable latch. The specific mapping of BOE[1:0] signals to the receive channel enable is listed in Table 14. When the latch is closed, if the device is reset (TRSTZ is sampled LOW), the latch is reset to disable the receive channel. |
| BOE[1:0] | LVTTL input, asynchronous, internal pull-up | BIST, serial output, and receive channel enables. These inputs are passed to and through the output enable latch when OELE = HIGH, and captured in this latch when OELE returns LOW. These inputs are passed to and through the BIST enable latch when BISTLE = HIGH, and captured in this latch when BISTLE returns LOW. These inputs are passed to and through the receive channel enable latch when RXLE = HIGH, and captured in this latch when RXLE returns LOW. |
| LFI | LVTTL output, asynchronous | Link fault indication output. Active LOW. LFI is the logical OR of four internal conditions: <ol style="list-style-type: none"> 1. Received serial data frequency outside expected range 2. Analog amplitude below expected levels 3. Transition density lower than expected 4. Receive channel disabled. |
| JTAG Interface | | |
| TMS | LVTTL input, internal pull-up | Test mode select. Used to control access to the JTAG test modes. If maintained high for ≥ 5 TCLK cycles, the JTAG test controller is reset. The TAP controller is also reset automatically upon application of power to the device. |
| TCLK | LVTTL input, internal pull-down | JTAG test clock. |
| TDO | Three-state LVTTL output | Test data out. JTAG data output buffer which is high Z while JTAG test mode is not selected. |
| TDI | LVTTL input, internal pull-up | Test data in. JTAG data input port. |
| Power | | |
| V _{CC} | | +3.3 V power |
| GND | | Signal and power ground for all internal circuits. |

CYP(V)15G0101DXB HOTLink II Operation

The CYP(V)15G0101DXB is a highly configurable device designed to support reliable transfer of large quantities of data using high-speed serial links from a single source to one or more destinations.

CYP(V)15G0101DXB Transmit Data Path

Operating Modes

The transmit path of the CYP(V)15G0101DXB supports a single character-wide data path. This data path is used in multiple operating modes as controlled by the TXMODE[1:0] inputs.

Input Register

The bits in the input register support different assignments, based on if the character is unencoded, encoded with two control bits, or encoded with three control bits. These assignments are shown in Table 1.

Table 1. Input Register Bit Assignments^[9]

| Signal Name | Unencoded (Encoder Bypassed) | Encoded (Encoder Enabled) | |
|---------------|------------------------------------|------------------------------|----------------------|
| | | Two-bit Control | Three-bit Control |
| TXD[0] (LSB) | DIN[0] | TXD[0] | TXD[0] |
| TXD[1] | DIN[1] | TXD[1] | TXD[1] |
| TXD[2] | DIN[2] | TXD[2] | TXD[2] |
| TXD[3] | DIN[3] | TXD[3] | TXD[3] |
| TXD[4] | DIN[4] | TXD[4] | TXD[4] |
| TXD[5] | DIN[5] | TXD[5] | TXD[5] |
| TXD[6] | DIN[6] | TXD[6] | TXD[6] |
| TXD[7] | DIN[7] | TXD[7] | TXD[7] |
| TXCT[0] | DIN[8] | TXCT[0] | TXCT[0] |
| TXCT[1] (MSB) | DIN[9] | TXCT[1] | TXCT[1] |
| SCSEL | N/A | N/A | SCSEL |

The input register captures a minimum of eight data bits and two control bits on each input clock cycle. When the encoder is bypassed, the TXCT[1:0] control bits are part of the pre-encoded 10-bit data character.

When the encoder is enabled (TXMODE[1] ≠ LOW), the TXCT[1:0] bits are interpreted along with the TXD[7:0] character to generate the specific 10-bit transmission character. When TXMODE[0] ≠ HIGH, an additional special character select (SCSEL) input is also captured and interpreted. This SCSEL input is used to modify the encoding of the characters.

Notes

9. The TXOP input is also captured in the input register, but its interpretation is under the separate control of PARCTL.

10. One or more K28.5 characters may be added or lost from the data stream during this reset operation. When used with non-Cypress devices that require a complete 16-character Word Sync Sequence for proper receive elasticity buffer alignment, it is recommended that the sequence be followed by a second Word Sync Sequence to ensure proper operation.

Phase-Align Buffer

Data from the input register is passed either to the encoder or to the phase-align buffer. When the transmit path is operated synchronous to REFCLK↑ (TXCKSEL = LOW and TXRATE = LOW), the phase-align buffer is bypassed and data is passed directly to the parity check and encoder block to reduce latency.

When an input register clock with an uncontrolled phase relationship to REFCLK is selected (TXCKSEL ≠ LOW) or if data is captured on both edges of REFCLK (TXRATE = HIGH), the phase-align buffer is enabled. This buffer is used to absorb clock phase differences between the presently selected input clock and the internal character clock.

Initialization of the phase-align buffer takes place when the TXRST input is sampled LOW by two consecutive rising edges of REFCLK. When TXRST is returned HIGH, the present input clock phase relative to REFCLK↑ is set. TXRST is an asynchronous input, but is sampled internally to synchronize it to the internal transmit path state machine.

Once set, the input clock is allowed to skew in time up to half a character period in either direction relative to REFCLK↑; that is ±180°. This time shift allows the delay path of the character clock (relative to REFCLK↑) to change due to operating voltage and temperature, while not affecting the design operation.

If the phase offset, between the initialized location of the input clock and REFCLK↑, exceeds the skew handling capabilities of the phase-align buffer, an error is reported on the TXPER output. This output indicates a continuous error until the phase-align buffer is reset. While the error remains active, the transmitter outputs a continuous C0.7 character to indicate to the remote receiver that an error condition is present in the link.

In specific transmit modes, it is also possible to reset the phase-align buffer with minimal disruption of the serial data stream. When the transmit interface is configured for generation of atomic Word Sync Sequences (TXMODE[1] = MID) and a phase-align buffer error is present, the transmission of a Word Sync Sequence will recenter the phase-align buffer and clear the error condition.^[10]

Parity Support

In addition to the ten data and control bits that are captured at the transmit input register, a TXOP input is also available. This allows the CYP(V)15G0101DXB to support ODD parity checking. Parity checking is available for all operating modes (including encoder bypass). The specific mode of parity checking is controlled by the PARCTL input, and operates per Table 2.

When PARCTL = MID (open) and the encoder is enabled (TXMODE[1] ≠ LOW), only the TXD[7:0] data bits are checked for ODD parity along with the TXOP bit. When PARCTL = HIGH with the encoder enabled (or MID with the encoder bypassed), the TXD[7:0] and TXCT[1:0] inputs are checked for ODD parity along with the TXOP bit. When PARCTL = LOW, parity checking is disabled.

When parity checking and the encoder are both enabled (TXMODE[1] ≠ LOW), the detection of a parity error causes a C0.7 character of proper disparity to be passed to the transmit shifter. When the encoder is bypassed (TXMODE[1] = LOW), detection of a parity error causes a positive disparity version of a C0.7 transmission character to be passed to the transmit shifter.

Table 2. Input Register Bits Checked for Parity^[12]

| Signal Name | Transmit Parity Check Mode (PARCTL) | | | HIGH |
|-------------|-------------------------------------|-------------------|-----------------|------|
| | LOW | MID | | |
| | | TXMODE[1] = LOW | TXMODE[1] ≠ LOW | |
| TXD[0] | | X ^[11] | X | X |
| TXD[1] | | X | X | X |
| TXD[2] | | X | X | X |
| TXD[3] | | X | X | X |
| TXD[4] | | X | X | X |
| TXD[5] | | X | X | X |
| TXD[6] | | X | X | X |
| TXD[7] | | X | X | X |
| TXCT[0] | | X | | X |
| TXCT[1] | | X | | X |
| TXOP | | X | X | X |

Encoder

The character, received from the input register or phase-align buffer and parity check logic, is then passed to the encoder logic. This block interprets each character and any control bits, and outputs a 10-bit transmission character.

Depending on the configured operating mode, the generated transmission character may be

- the 10-bit pre-encoded character accepted in the input register
- the 10-bit equivalent of the eight-bit data character accepted in the input register
- the 10-bit equivalent of the eight-bit special character code accepted in the input register
- the 10-bit equivalent of the C0.7 SVS character if parity checking was enabled and a parity error was detected
- the 10-bit equivalent of the C0.7 SVS character if a phase-align buffer overflow or underflow error is present
- a character that is part of the 511-character BIST sequence
- a K28.5 character generated as an individual character or as part of the 16-character Word Sync Sequence.

The selection of the specific characters generated are controlled by the TXMODE[1:0], SCSEL, TXCT[1:0], and TXD[7:0] inputs for each character.

Notes

11. Bits marked as X are XORed together. Result must be a logic-1 for parity to be valid.
 12. Transmit path parity errors are reported on the TXPER output.

Data Encoding

Raw data, as received directly from the transmit input register, is seldom in a form suitable for transmission across a serial link. The characters must usually be processed or transformed to guarantee

- a minimum transition density (to allow the serial receive PLL to extract a clock from the data stream)
- a DC-balance in the signaling (to prevent baseline wander)
- run-length limits in the serial data (to limit the bandwidth of the link)
- the remote receiver a way of determining the correct character boundaries (framing).

When the encoder is enabled (TXMODE[1] ≠ LOW), the characters to be transmitted are converted from data or special character codes to 10-bit transmission characters (as selected by the TXCT[1:0] and SCSEL inputs), using an integrated 8B/10B encoder. When directed to encode the character as a special character code, it is encoded using the special character encoding rules listed in Table 21. When directed to encode the character as a data character, it is encoded using the data character encoding rules in Table 20.

The 8B/10B encoder is standards compliant with ANSI/NCITS ASC X3.230-1994 (fibre channel), IEEE 802.3z (gigabit ethernet), the IBM® ESCON® and FICON™, and digital video broadcast (DVB-ASI) standards for data transport.

Many of the special character codes listed in Table 21 may be generated by more than one input character. The CYP(V)15G0101DXB is designed to support two independent (but non-overlapping) special character code tables. This allows the CYP(V)15G0101DXB to operate in mixed environments with other Cypress HOTLink devices using the enhanced Cypress command code set, and the reduced command sets of other non-Cypress devices. Even when used in an environment that normally uses non-Cypress special character codes, the selective use of Cypress command codes can permit operation where running disparity and error handling must be managed.

Following conversion of each input character from eight bits to a 10-bit transmission character, it is passed to the transmit shifter and is shifted out LSB first, as required by ANSI and IEEE standards for 8B/10B coded serial data streams.

Transmit Modes

The operating mode of the transmit path is set through the TXMODE[1:0] inputs. These 3-level select inputs allow one of nine transmit modes to be selected. The transmit modes are listed in Table 3.

The encoded modes (TX modes 3 through 8) support multiple encoding tables. These encoding tables vary by the specific combinations of SCSEL, TXCT[1], and TXCT[0] that are used to control the generation of data and control characters. These multiple encoding forms allow maximum flexibility in interfacing to legacy applications, while also supporting numerous extensions in capabilities. TX Mode 0—encoder bypass

When the encoder is bypassed, the character captured from the TXD[7:0] and TXCT[1:0] inputs is passed directly to the transmit shifter without modification. If parity checking is enabled (PARCTL ≠ LOW) and a parity error is detected, the 10-bit character is replaced with the 1001111000 pattern (+C0.7 character) regardless of the running disparity of the previous character.

With the encoder bypassed, the TXCT[1:0] inputs are considered part of the data character and do not perform a control function that would otherwise modify the interpretation of the TXD[7:0] bits. The bit usage and mapping of these control bits when the encoder is bypassed is shown in Table 4.

In encoder bypass mode, the SCSEL input is ignored. All clocking modes interpret the data in the same way.

Table 3. Transmit Operating Modes

| TX Mode | | Operating Mode | | |
|-------------|--------------|----------------------------|-------------------|-------------------|
| Mode Number | TXMODE [1:0] | Word Sync Sequence Support | SCSEL Control | TXCT Function |
| 0 | LL | None | None | Encoder bypass |
| 1 | LM | None | None | Reserved for test |
| 2 | LH | None | None | Reserved for test |
| 3 | ML | Atomic | Special Character | Encoder control |
| 4 | MM | Atomic | Word Sync | Encoder control |
| 5 | MH | Atomic | None | Encoder control |
| 6 | HL | Interruptible | Special Character | Encoder control |
| 7 | HM | Interruptible | Word Sync | Encoder control |
| 8 | HH | Interruptible | None | Encoder control |

Table 4. Encoder Bypass Mode (TXMODE[1:0] = LL)

| Signal Name | Bus Weight | 10B Name |
|------------------------------|----------------|----------|
| TXD[0] (LSB) ^[13] | 2 ⁰ | a |
| TXD[1] | 2 ¹ | b |
| TXD[2] | 2 ² | c |
| TXD[3] | 2 ³ | d |
| TXD[4] | 2 ⁴ | e |
| TXD[5] | 2 ⁵ | i |
| TXD[6] | 2 ⁶ | f |
| TXD[7] | 2 ⁷ | g |
| TXCT[0] | 2 ⁸ | h |
| TXCT[1] (MSB) | 2 ⁹ | j |

Note
13. LSB is shifted out first.

TX Modes 1 and 2—Factory Test Modes

These modes enable specific factory test configurations. They are not considered normal operating modes of the device. Entry or configuration into these test modes will not damage the device.

TX Mode 3—Atomic Word Sync and SCSEL Control of Special Codes

When configured in TX Mode 3, the SCSEL input is captured along with the TXCT[1:0] data control inputs. These bits combine to control the interpretation of the TXD[7:0] bits and the characters generated by them. These bits are interpreted as listed in Table 5.

Table 5. TX Modes 3 and 6 Encoding

| SCSEL | TXCT[1] | TXCT[0] | Characters Generated |
|-------|---------|---------|---------------------------------|
| X | X | 0 | Encoded data character |
| 0 | 0 | 1 | K28.5 fill character |
| 1 | 0 | 1 | Special character code |
| X | 1 | 1 | 16-character Word Sync Sequence |

When TXCKSEL = MID or HIGH, the transmit channel captures data into its input register using the TXCLK clock.

Word Sync Sequence

When TXCT[1:0] = 11, a 16-character sequence of K28.5 characters, known as a Word Sync Sequence, is generated on the transmit channel. This sequence of K28.5 characters may start with either a positive or negative disparity K28.5 (as determined by the current running disparity and the 8B/10B coding rules). The disparity of the second and third K28.5 characters in this sequence are reversed from what normal 8B/10B coding rules would generate. The remaining K28.5 characters in the sequence follow all 8B/10B coding rules. The disparity of the generated K28.5 characters in this sequence follow a pattern of either + + - - + - + - + - + - + - or - - + + - + - + - + - + - + -.

When TXMODE[1] = MID (open, TX modes 3, 4 and 5), the generation of this character sequence is an atomic (non-interruptible) operation. Once it has been successfully started, it cannot be stopped until all 16 characters have been generated. The content of the input register is ignored for the duration of this 16-character sequence. At the end of this sequence, if the TXCT[1:0] = 11 condition is sampled again, the sequence restarts and remains uninterrupted for the following 15 character clocks.

If parity checking is enabled, the character used to start the Word Sync Sequence must also have correct ODD parity. This is true even though the contents of the TXD[7:0] bits do not directly control the generation of characters during the Word Sync Sequence. Once the sequence is started, parity is not checked on the following 15 characters in the Word Sync Sequence.

When TXMODE[1] = HIGH (TX modes 6, 7, and 8), the generation of the Word Sync Sequence becomes an interruptible operation. In TX Mode 6, this sequence is started as soon as the TXCT[1:0] = 11 condition is detected on the channel. In order for the sequence to continue, the TXCT[1:0] inputs must be sampled as 00 for the remaining 15 characters of the sequence. If at any time a sample period exists where TXCT[1:0] ≠ 00, the Word Sync Sequence is terminated, and a character representing the data and control bits is generated by the encoder. This resets the Word Sync Sequence state machine such that it will start at the beginning of the sequence at the next occurrence of TXCT[1:0] = 11.

When parity checking is enabled and TXMODE[1] = HIGH, all characters (including those in the middle of a Word Sync Sequence) must have correct parity. The detection of a character with incorrect parity during a Word Sync Sequence (regardless of the state of TXCT[1:0]) will interrupt that sequence and force generation of a C0.7 SVS character. Any interruption of the Word Sync Sequence causes the sequence to terminate.

When TXCKSEL = LOW, the input register for the transmit channel is clocked by REFCLK.^[14] When TXCKSEL = HIGH or MID, the input register for the transmit channel is clocked with TXCLK↑.

TX Mode 4—Atomic Word Sync and SCSEL Control of Word Sync Sequence Generation

When configured in TX Mode 4, the SCSEL input is captured along with the TXCT[1:0] data control inputs. These bits combine to control the interpretation of the TXD[7:0] bits and the characters generated by them. These bits are interpreted as listed in Table 6.

Table 6. TX Modes 4 and 7 Encoding

| SCSEL | TXCT[1] | TXCT[0] | Characters Generated |
|-------|---------|---------|---------------------------------|
| X | X | 0 | Encoded data character |
| 0 | 0 | 1 | K28.5 fill character |
| 0 | 1 | 1 | Special character code |
| 1 | X | 1 | 16-character Word Sync Sequence |

TX Mode 4 also supports an Atomic Word Sync Sequence. Unlike TX Mode 3, this sequence is started when both SCSEL and TXCT[0] are sampled HIGH. With the exception of the combination of control bits used to initiate the sequence, the generation and operation of this Word Sync Sequence is the same as that documented for TX Mode 3.

TX Mode 5—Atomic Word Sync, No SCSEL

When configured in TX Mode 5, the SCSEL signal is not used. The TXCT[1:0] inputs control the characters generated by the channel. The specific characters generated by these bits are listed in Table 7.

Table 7. TX Modes 5 and 8 Encoding

| SCSEL | TXCT[1] | TXCT[0] | Characters Generated |
|-------|---------|---------|---------------------------------|
| X | 0 | 0 | Encoded data character |
| X | 0 | 1 | K28.5 fill character |
| X | 1 | 0 | Special character code |
| X | 1 | 1 | 16-character Word Sync Sequence |

TX Mode 5 also has the capability of generating an Atomic Word Sync Sequence. For the sequence to be started, the TXCT[1:0] inputs must both be sampled HIGH. The generation and operation of this Word Sync Sequence is the same as that documented for TX Mode 3.

Transmit BIST

The transmit channel contains an internal pattern generator that can be used to validate both device and link operation. This generator is enabled by the BOE[1] signal, as listed in Table 8 (when the BISTLE latch enable input is HIGH). When enabled, a register in the transmit channel becomes a signature pattern generator by logically converting to a linear feedback shift register (LFSR). This LFSR generates a 511-character sequence that includes all data and special character codes, including the explicit violation symbols. This provides a predictable yet pseudo-random sequence that can be matched to an identical LFSR in the attached Receiver. If the receive channel is configured for REFCLK clocking (RXCKSEL = LOW), each pass is preceded by a 16-character Word Sync Sequence to allow elasticity buffer alignment and management of clock-frequency variations.

When the BISTLE signal is HIGH, if the BOE[1] input is LOW, the BIST generator in the transmit channel is enabled (and if BOE[0] = LOW the BIST checker in the receive channel is enabled). When BISTLE returns LOW, the values of the BOE[1:0] signals are captured in the BIST enable latch. These values remain in the BIST enable latch until BISTLE is returned high to open the latch again. A device reset (TRSTZ sampled LOW), also presets the BIST enable latch to disable BIST on both the transmit and receive channels.

All data and data-control information present at the TXD[7:0] and TXCT[1:0] inputs are ignored when BIST is active on the transmit channel.

Note

14. When REFCLK is configured for half-rate operation (TXRATE = HIGH), this input is sampled (or the outputs change) relative to both the rising and falling edges of REFCLK.

Serial Output Drivers

The serial interface output drivers use high-performance differential current mode logic (CML) to provide source-matched drivers for the transmission lines. These serial drivers accept data from the transmit shifter. These outputs have signal swings equivalent to that of standard PECL drivers, and are capable of driving AC-coupled optical modules or AC-coupled transmission lines.

When configured for local loop-back (LPEN = HIGH), the enabled serial drivers are configured to drive a static differential logic-1.

Each serial driver can be enabled or disabled through the BOE[1:0] inputs, as controlled by the OELE latch-enable signal. When OELE = HIGH, the signals present on the BOE[1:0] inputs are passed through the serial output enable latch to control the serial driver. The BOE[1:0] input with OUT1± and OUT2± driver is listed in Table 8.

Table 8. Output Enable, BIST, and Receive Channel Enable Signal Map

| BOE Input | Output Controlled (OELE) | BIST Channel Enable (BISTLE) | Receive PLL Channel Enable (RXLE) |
|-----------|--------------------------|------------------------------|-----------------------------------|
| BOE[1] | OUT2± | Transmit | X |
| BOE[0] | OUT1± | Receive | Receive |

When OELE = HIGH and BOE[x] = HIGH, the associated serial driver is enabled to drive any attached transmission line. When OELE = HIGH and BOE[x] = LOW, the associated driver is disabled and internally configured for minimum power dissipation. If both serial drivers for the channel are disabled, the internal logic for the transmit channel is also configured for lowest power operation. When OELE returns LOW, the values present on the BOE[1:0] inputs are latched in the output enable latch, and remain there until OELE returns HIGH to open the latch again. A device reset (TRSTZ sampled LOW) clears this latch and disables both serial drivers.

Note. When both serial output drivers are disabled and a driver is re-enabled, the data on the serial drivers may not meet all timing specifications for up to 200 µs.

Transmit PLL Clock Multiplier

The transmit PLL clock multiplier accepts a character-rate or half-character-rate external clock at the REFCLK input, and multiplies that clock by 10 or 20 (as selected by TXRATE) to generate a bit-rate clock for use by the transmit shifter. It also provides a character-rate clock used by the transmit path.

This clock multiplier PLL can accept a REFCLK input between 19.5 MHz and 150 MHz, however, this clock range is limited by the operating mode of the CYP(V)15G0101DXB clock multiplier (controlled by TXRATE) and by the level on the SPDSEL input.

When TXRATE=HIGH, configuring TXCKSEL = HIGH or MID is an invalid mode of operation.

SPDSEL is a 3-level select^[15] (ternary) input that selects one of three operating ranges for the serial data outputs and inputs. The operating serial signaling-rate and allowable range of REFCLK frequencies are listed in Table 9.

Table 9. Operating Speed Settings

| SPDSEL | TXRATE | REFCLK Frequency (MHz) | Signaling Rate (Mbaud) |
|------------|--------|------------------------|------------------------|
| LOW | 1 | Reserved | 195–400 |
| | 0 | 19.5–40 | |
| MID (Open) | 1 | 20–40 | 400–800 |
| | 0 | 40–80 | |
| HIGH | 1 | 40–75 | 800–1500 |
| | 0 | 80–150 | |

The REFCLK± input is a differential input with each input internally biased to 1.4 V. If the REFCLK+ input is connected to a TTL, LVTTTL, or LVCMOS clock source, the input signal is recognized when it passes through the internally biased reference point.

When both the REFCLK+ and REFCLK– inputs are connected, the clock source must be a differential clock. This can be either a differential LVPECL clock that is DC- or AC-coupled, or a differential LVTTTL or LVCMOS clock.

By connecting the REFCLK– input to an external voltage source or resistive voltage divider, it is possible to adjust the reference point of the REFCLK+ input for alternate logic levels. When doing so, it is necessary to ensure that the 0 V-differential crossing point remains within the parametric range supported by the input.

CYP(V)15G0101DXB Receive Data Path

Serial Line Receivers

Two differential line receivers, IN1± and IN2±, are available for accepting serial data streams. The active serial line receiver is selected using the INSEL input. Both serial line receivers have differential inputs, and can accommodate wire interconnect and filtering losses or transmission line attenuation greater than 16 dB. For normal operation, these inputs should receive a signal of at least $V_{DIFFS} > 100$ mV, or 200-mV peak-to-peak differential. Each line receiver can be DC- or AC-coupled to +3.3 V powered fiber-optic interface modules (any ECL/PECL logic family, not limited to 100 K PECL) or AC-coupled to +5 V-powered optical modules. The common-mode tolerance of the receivers accommodates a wide range of signal termination voltages. Each receiver provides internal DC-restoration, to the center of the receiver's common mode range, for AC-coupled signals.

Note

15. When REFCLK is configured for half-rate operation (TXRATE = HIGH), this input is sampled (or the outputs change) relative to both the rising and falling edges of REFCLK.

The local loop-back input (LPEN) allows the serial transmit data to be routed internally back to the clock and data recovery circuit. When configured for local loop-back, the transmit serial driver outputs are forced to output a differential logic-1. This prevents local diagnostic patterns from being broadcast to attached remote receivers.

Signal Detect/Link Fault

Each selected line receiver (i.e., that routed to the clock and data recovery PLL) is simultaneously monitored for

- analog amplitude above limit specified by SDASEL
- transition density greater than specified limit
- range controller reports the received data stream within normal frequency range (± 1500 ppm)^[16]
- receive channel enabled.

All of these conditions must be valid for the signal detect block to indicate a valid signal is present. This status is presented on the LFI (link fault indicator) output.

Analog Amplitude

While most signal monitors are based on fixed constants, the analog amplitude level detection is adjustable to allow operation with highly attenuated signals, or in high-noise environments. This adjustment is made through the SDASEL signal, a 3-level select^[17] (ternary) input, which sets the trip point for the detection of a valid signal at one of three levels, as listed in Table 10.

The analog signal detect monitor is active for the present line receiver, as selected by the INSEL input. When configured for local loop-back (LPEN = HIGH), the analog signal detect monitor is disabled.

Transition Density

The transition detection logic checks for the absence of any transitions spanning greater than six transmission characters (60-bits). If no transitions are present in the data received (within the referenced period), the transition detection logic asserts LFI. The LFI output remains asserted until at least one transition is detected in each of three adjacent received characters.

Table 10. Analog Amplitude Detect Valid Signal Levels^[18]

| SDASEL | Typical Signal with Peak Amplitudes Above |
|------------|---|
| LOW | 140-mV p-p differential |
| MID (Open) | 280-mV p-p differential |
| HIGH | 420-mV p-p differential |

Notes

16. REFCLK has no phase or frequency relationship with the recovered clock(s) and only acts as a centering reference to reduce clock synchronization time. REFCLK must be within ± 1500 PPM ($\pm 0.15\%$) of the remote transmitter's PLL reference (REFCLK) frequency. Although transmitting to a HOTLink II receiver necessitates the frequency difference between the transmitter and receiver reference clocks to be within ± 1500 -PPM, the stability of the crystal needs to be within the limits specified by the appropriate standard when transmitting to a remote receiver that is compliant to that standard. For example, to be IEEE 802.3z Gigabit Ethernet compliant, the frequency stability of the crystal needs to be within ± 100 PPM.
17. When REFCLK is configured for half-rate operation (TXRATE = HIGH), this input is sampled (or the outputs change) relative to both the rising and falling edges of REFCLK.
18. The peak amplitudes listed in this table are for typical waveforms that have generally 3–4 transitions for every ten bits. In a worse case environment the signals may have a sign-wave appearance (highest transition density with repeating 0101...). Signal peak amplitudes levels within this environment type could increase the values in the table above by approximately 100 mV.
19. When a disabled receive channel is reenabled, the status of the LFI output and data on the parallel outputs may be indeterminate for up to 2 ms.

Range Control

The clock/data recovery (CDR) circuit includes logic to monitor the frequency of the phase-locked loop (PLL) voltage controlled oscillator (VCO) used to sample the incoming data stream. This logic ensures that the VCO operates at, or near the rate of the incoming data stream for two primary cases:

- when the incoming data stream resumes after a time in which it has been "missing."
- when the incoming data stream is outside the acceptable frequency range.

To perform this function, the frequency of the VCO is periodically sampled and compared to the frequency of the REFCLK input. If the VCO is running at a frequency beyond ± 1500 ppm^[16] as defined by the reference clock frequency, it is periodically forced to the correct frequency (as defined by REFCLK, SPDSEL, and TXRATE) and then released in an attempt to lock to the input data stream. The sampling and relock period of the range control is calculated as follows: RANGE CONTROL SAMPLING PERIOD = (REFCLKPERIOD) \times (16000).

During the time that the range control forces the PLL VCO to run at REFCLK \times 10 (or REFCLK \times 20 when TXRATE = HIGH) rate, the LFIx output will be asserted LOW. While the PLL is attempting to re-lock to the incoming data stream, LFIx may be either HIGH or LOW (depending on other factors such as transition density and amplitude detection) and the recovered byte clock (RXCLK) may run at an incorrect rate (depending on the quality or existence of the input serial data stream). After a valid serial data stream is applied, it may take up to one RANGE CONTROL SAMPLING PERIOD before the PLL locks to the input data stream, after which LFIx should be HIGH.

Receive Channel Enabled

The CYP(V)15G0101DXB receive channel can be enabled and disabled through the BOE[0] input, as controlled by the RXLE latch-enable signal. When RXLE = HIGH, the signal present on the BOE[0] input is passed through the receive channel enable latch to control the PLL and logic of the receive channel. The BOE[1:0] input functions are listed in Table 8.

When RXLE = HIGH and BOE[0] = HIGH, the receive channel is enabled to receive and recover a serial stream from the line receiver. When RXLE = HIGH and BOE[0] = LOW, the receive channel is disabled and internally configured for minimum power dissipation. When disabled, the channel indicates a constant LFI output. When RXLE returns LOW, the values present on the BOE[1:0] inputs are latched in the Receive Channel Enable Latch, and remain there until RXLE returns HIGH to open the latch again.^[19]

Clock/Data Recovery

The extraction of a bit-rate clock and recovery of bits from a received serial stream is performed by a CDR block within the receive channel. The clock extraction function is performed by a high-performance embedded PLL that tracks the frequency of the transitions in the incoming bit stream and aligns the phase of the internal bit-rate clock to the transitions in the serial data stream.

The CDR accepts a character-rate (bit-rate ÷ 10) or half-character-rate (bit-rate ÷ 20) reference clock from the REFCLK input. This REFCLK input is used to

- ensure that the VCO (within the CDR) is operating at the correct frequency
- reduce PLL acquisition time
- limit unlocked frequency excursions of the CDR VCO when there is no input data present at the selected serial line receiver.

Regardless of the type of signal present, the CDR will attempt to recover a data stream from it. If the frequency of the recovered data stream is outside the limits of the range control monitor, the CDR will switch to track REFCLK instead of the data stream. Once the CDR output (RXCLK) frequency returns back close to REFCLK frequency, the CDR input will be switched back to track the input data stream. In case no data is present at the input, this switching behavior may result in brief RXCLK frequency excursions from REFCLK. However, the validity of the input data stream is indicated by the LFIx output. The frequency of REFCLK is required to be within ± 1500 ppm^[20] of the frequency of the clock that drives the REFCLK input of the remote transmitter to ensure a lock to the incoming data stream.

For systems using multiple or redundant connections, the $\overline{\text{LFI}}$ output can be used to select an alternate data stream. When an LFI indication is detected, external logic can toggle selection of the IN1± and IN2± inputs through the INSEL input. When a port switch takes place, it is necessary for the receive PLL to reacquire the new serial stream and frame to the incoming character boundaries.

Deserializer/Framer

Each CDR circuit extracts bits from the serial data stream and clocks these bits into the shifter/framer at the bit-clock rate. When enabled, the framer examines the data stream, looking for one or more comma or K28.5 characters at all possible bit positions. The location of these characters in the data stream are used to determine the character boundaries of all following characters.

Framing Character

The CYP(V)15G0101DXB allows selection of two combinations of framing characters to support requirements of different interfaces. The selection of the framing character is made through the FRAMCHAR input.

The specific bit combinations of these framing characters are listed in Table 11. When the specific bit combination of the selected framing character is detected by the framer, the boundaries of the characters present in the received data stream are known.

Table 11. Framing Character Selector

| FRAMCHAR | Bits Detected in Framer | |
|------------|-------------------------|---|
| | Character Name | Bits Detected |
| LOW | Reserved for test | |
| MID (Open) | Comma+ Comma– | 00111110XX ^[21] or 11000001XX |
| HIGH | –K28.5 +K28.5 | 0011111010 or 1100000101 |

Framer

The framer operates in one of three different modes, as selected by the RFMODE input. In addition, the framer itself may be enabled or disabled through the RFEN input. When RFEN = LOW, the framer is disabled, and no combination of bits in a received data stream will alter the character boundaries. When RFEN = HIGH, the framer-mode selected by RFMODE is enabled.

When RFMODE = LOW, the low-latency framer is selected. This framer operates by stretching the recovered character clock until it aligns with the received character boundaries. In this mode, the framer starts its alignment process on the first detection of the selected framing character. To reduce the impact on external circuits that make use of a recovered clock, the clock period is not stretched by more than two bit-periods in any one clock cycle. When operated with a character-rate output clock (RXRATE = LOW), the output of properly framed characters may be delayed by up to nine character-clock cycles from the detection of the selected framing character. When operated with a half-character-rate output clock (RXRATE = HIGH), the output of properly framed characters may be delayed by up to 14 character-clock cycles from the detection of the selected framing character.^[22]

Notes

20. REFCLK has no phase or frequency relationship with the recovered clock(s) and only acts as a centering reference to reduce clock synchronization time. REFCLK must be within ±1500 ppm (±0.15%) of the remote transmitter's PLL reference (REFCLK) frequency. Although transmitting to a HOTLink II receiver necessitates the frequency difference between the transmitter and receiver reference clocks to be within ±1500 ppm, the stability of the crystal needs to be within the limits specified by the appropriate standard when transmitting to a remote receiver that is compliant to that standard. For example, to be IEEE 802.3z Gigabit Ethernet compliant, the frequency stability of the crystal needs to be within ±100 ppm.
21. The standard definition of a Comma contains only seven bits. However, since all valid Comma characters within the 8B/10B character set also have the 8th bit as an inversion of the 7th bit, the compare pattern is extended to a full eight bits to reduce the possibility of a framing error.
22. When receive BIST is enabled on a channel, the low-latency framer must not be enabled. The BIST sequence contains an aliased K28.5 framing character, which would cause the receiver to update its character boundaries incorrectly.

When RFMODE = MID (open), the Cypress-mode multi-byte framer is selected. The required detection of multiple framing characters makes the link much more robust to incorrect framing due to aliased framing characters in the data stream. In this mode, the framer does not adjust the character clock boundary, but instead aligns the character to the already recovered character clock. This ensures that the recovered clock does not contain any significant phase changes or hops during normal operation or framing, and allows the recovered clock to be replicated and distributed to other external circuits or components using PLL-based clock distribution elements. In this framing mode, the character boundaries are only adjusted if the selected framing character is detected at least twice within a span of 50-bits, with both instances on identical 10-bit character boundaries.

When RFMODE = HIGH, the alternate-mode multi-byte framer is enabled. Like the Cypress-mode multi-byte framer, multiple framing characters must be detected before the character boundary is adjusted. In this mode, the framer does not adjust the character clock boundary, but instead aligns the character to the already recovered character clock. In this mode, the data stream must contain a minimum of four of the selected framing characters, received as consecutive characters, on identical 10-bit boundaries, before character framing is adjusted.

Framing is enabled when RFEN = HIGH. If RFEN = LOW, the framer is disabled. When the framer is disabled, no changes are made to the recovered character boundary, regardless of the presence of framing characters in the data stream.

10B/8B Decoder Block

The decoder logic block performs three primary functions:

- decoding the received transmission characters back into data and special character codes
- comparing generated BIST patterns with received characters to permit at-speed link and device testing
- generation of ODD parity on the decoded characters.

10B/8B Decoder

The framed parallel output of the deserializer shifter is passed to the 10B/8B decoder where, if the decoder is enabled (DECMODE ≠ LOW), it is transformed from a 10-bit transmission character back to the original data and special character codes. This block uses the 10B/8B decoder patterns in [Table 20](#) and [Table 21](#) of this data sheet. Valid data characters are indicated by a 000b bit-combination on the RXST[2:0] status bits, and special character codes are indicated by a 001b bit-combination on these same status outputs. Framing characters, invalid patterns, disparity errors, and synchronization status are presented as alternate combinations of these status bits.

The 10B/8B decoder operates in two normal modes, and can also be bypassed. The operating mode for the decoder is controlled by the DECMODE input.

When DECMODE = LOW, the decoder is bypassed and raw 10-bit characters are passed to the output register. In this mode, the receive elasticity buffers are bypassed, and RXCKSEL must be MID.

When DECMODE = MID (or open), the 10-bit transmission characters are decoded using [Table 20](#) and [Table 21](#). Received special code characters are decoded using the Cypress column of [Table 21](#).

When DECMODE = HIGH, the 10-bit transmission characters are decoded using [Table 20](#) and [Table 21](#). Received special code characters are decoded using the alternate column of [Table 21](#).

Receive BIST Operation

The receiver interface contains an internal pattern generator that can be used to validate both device and link operation. This generator is enabled by the BOE[0] signal as listed in [Table 8](#) (when the BISTLE latch enable input is HIGH). When enabled, a register in the receive channel becomes a pattern generator and checker by logically converting to a linear feedback shift register (LFSR). This LFSR generates a 511-character sequence that includes all data and special character codes, including the explicit violation symbols. This provides a predictable yet pseudo-random sequence that can be matched to an identical LFSR in the attached transmitter. If the receive channels are configured for REFCLK clocking (RXCKSEL = LOW), each pass is preceded by a 16-character Word Sync Sequence.

When synchronized with the received data stream, the receiver checks each character in the decoder with each character generated by the LFSR and indicates compare errors and BIST status at the RXST[2:0] bits of the output register.

When the BISTLE signal is HIGH, if the BOE[0] input is LOW the BIST generator/checker in the receive channel is enabled (and if BOE[1] = LOW the BIST generator in the transmit channel is enabled). When BISTLE returns LOW, the values of the BOE[1:0] signals are captured in the BIST enable latch. These values remain in the BIST enable latch until BISTLE is returned high to open the latch again. All captured signals in the BIST enable latch are set HIGH (i.e., BIST is disabled) following a device reset (TRSTZ is sampled LOW).

When BIST is first recognized as being enabled in the receiver, the LFSR is preset to the BIST-loop start-code of D0.0. This D0.0 character is sent only once per BIST loop. The status of the BIST progress and any character mismatches is presented on the RXST[2:0] status outputs.

Code rule violations or running disparity errors that occur as part of the BIST loop do not cause an error indication. RXST[2:0] indicates 010b or 100b for one character period per BIST loop to indicate loop completion. This status can be used to check test pattern progress. These same status values are presented when the decoder is bypassed and BIST is enabled on the receive channel.

The status reported on RXST[2:0] by the BIST state machine are listed in [Table 16](#). When receive BIST is enabled, the same status is reported on the receive status outputs regardless of the state of DECMODE.

The specific patterns checked by each receiver are described in detail in the Cypress application note [HOTLink Built-In Self-test](#). The sequence compared by the CYP(V)15G0101DXB is identical to that in the CY7B933 and CY7C924DX, allowing interoperable systems to be built when used at compatible serial signaling rates.

If the number of invalid characters received ever exceeds the number of valid characters by 16, the receive BIST state machine aborts the compare operations and resets the LFSR to the D0.0 state to look for the start of the BIST sequence again.

When the receive paths are configured for REFCLK clocking (RXCKSEL = LOW), each pass must be preceded by a 16-character Word Sync Sequence to allow output buffer alignment and management of clock frequency variations. This is automatically generated by the transmitter when its local RXCKSEL = LOW.

The BIST state machine requires the characters to be correctly framed for it to detect the BIST sequence. If the low-latency framer is enabled (RFMODE = LOW), the framer will misalign to an aliased framing character within the BIST sequence. If the alternate-mode multi-byte framer is enabled (RFMODE = HIGH) and the receiver outputs are clocked relative to a recovered clock (RXCKSEL = MID), it is necessary to frame the receiver before BIST is enabled. If the receiver outputs are clocked relative to REFCLK (RXCKSEL = LOW), the transmitter precedes every 511 character BIST sequence with a 16-character Word Sync Sequence.

Receive Elasticity Buffer

The receive channel contains an elasticity buffer that is designed to support multiple clocking modes. This buffer allows data to be read using an elasticity buffer read-clock that is asynchronous in both frequency and phase from the elasticity buffer write clock, or to use a read clock that is frequency coherent but with uncontrolled phase relative to the elasticity buffer write clock.

The elasticity buffer is 10 characters deep, and supports a 12-bit-wide data path. It is capable of supporting a decoded character, three status bits, and a parity bit for each character present in the buffer. The write clock for this buffer is always the recovered clock for the read channel.

The read clock for the elasticity buffer can be set to character-rate REFCLK (RXCKSEL = LOW and DECMODE ≠ LOW). The write clock for the elasticity buffer is always recovered clock.

When RXCKSEL = LOW, the receive channel is clocked by REFCLK. The RXCLK± and RXCLKC+ outputs present buffered and delayed forms of REFCLK. In this mode, the receive elasticity buffer is enabled. For REFCLK clocking, the elasticity buffer must be able to insert K28.5 characters and delete framing characters as appropriate. The elasticity buffer is bypassed whenever the decoder is bypassed (DECMODE = LOW). When the decoder and elasticity buffer are bypassed, RXCKSELx must be set to MID. When RXCKSEL = MID (or open), the receive channel output register is clocked by the recovered clock.

The insertion of a K28.5 or deletion of a framing character can occur at any time. However, the actual timing on these insertions and deletions is controlled in part by the how the transmitter sends its data. Insertion of a K28.5 character can only occur when the receiver has a framing character in the elasticity buffer. Likewise, to delete a framing character, one must also be present in the elasticity buffer. To prevent an elasticity buffer overflow or underflow in the receive channel, a minimum density of framing characters must be present in the received data stream.

Prior to reception of valid data, at least one Word Sync Sequence (or at least four framing characters) must be received to allow the receive elasticity buffer to be centered. The elasticity buffer may

also be centered by a device reset operation initiated through the TRSTZ input. However, following such an event, the CYP(V)15G0101DXB will normally require a framing event before it will correctly decode characters.

Receive Modes

The operating mode of the receive path is set through the RXMODE input. The 'Reserved for test' setting (RXMODE = M) is not allowed, even if the receiver is not being used, as it will stop normal function of the device. When the decoder is disabled, the RXMODE setting is ignored as long as it is not a test mode. These modes determine the RXST status reporting. The different receive modes are listed in Table 12.

Table 12. Receive Operating Modes

| RX Mode | | RXST Status Reporting |
|-------------|--------|-----------------------|
| Mode Number | RXMODE | |
| 0 | L | Status A |
| 1 | M | Reserved for test |
| 2 | H | Status B |

Power Control

The CYP(V)15G0101DXB supports user control of the powered up or down state of the transmit and receive channel. The receive channel is controlled by the RXLE signal and the values present on the BOE[1:0] bus. The transmit channel is controlled by the OELE signal and the values present on the BOE[1:0] bus. If either the transmit or the receive channel is not used, then powering down the unused channel will save power and reduce system heat generation. Controlling system power dissipation will improve the system performance.

Receive Channel

When RXLE = HIGH, the signal on the BOE[0] input directly controls the power enable for the receive PLL and the analog circuit. When BOE[0] = HIGH, the receive channel and its analog circuits are active. When BOE[0] = LOW, the receive channel and its analog circuits are powered down. When RXLE returns LOW, the values present on the BOE[1:0] inputs are latched in the receive channel enable latch. When a disabled receive channel is re-enabled, the status of the LFI output and data on the parallel outputs for the receive channel may be indeterminate for up to 2 ms.

Transmit Channel

When OELE = HIGH, the signals on the BOE[1:0] inputs directly control the power enables for the serial drivers. When a BOE[1:0] input is HIGH, the associated serial driver is enabled. When a BOE[1:0] input is LOW, the associated serial driver is disabled. When both serial drivers are powered down, the logic in the entire transmit channel is also powered down. When OELE returns LOW, the values present on the BOE[1:0] inputs are latched in the output enable latch.

Device Reset State

When the CYP(V)15G0101DXB is reset by assertion of $\overline{\text{TRSTZ}}$, both the transmit enable and receive enable latches are cleared, and the BIST enable latch is preset. In this state, the transmit and receive channels are disabled, and BIST is disabled.

Following a device reset, it is necessary to enable the transmit and receive channels for normal operation. This can be done by sequencing the appropriate values on the BOE[1:0] inputs while the OELE and RXLE signals are raised and lowered. For systems that do not require dynamic control of power, or want the part to power-up in a fixed configuration, it is also possible to strap the RXLE and OELE control signals HIGH to permanently enable their associated latches. Connection of the associated BOE[1:0] signals to a stable HIGH will then enable the transmit and receive channels as soon as the TRSTZ signal is deasserted.

Output Bus

The receive channel presents a 12-signal output bus consisting of

- an eight-bit data bus
- a three-bit status bus
- a parity bit.

The bit assignments of the Data and Status are dependent on the setting of DECMODE. This mapping is shown in Table 13.

Table 13. Output Register Bit Assignments^[23]

| Signal Name | DECMODE = LOW | DECMODE = MID or HIGH |
|---------------|---------------|-----------------------|
| RXST[2] (LSB) | COMDET | RXST[2] |
| RXST[1] | DOUT[0] | RXST[1] |
| RXST[0] | DOUT[1] | RXST[0] |
| RXD[0] | DOUT[2] | RXD[0] |
| RXD[1] | DOUT[3] | RXD[1] |
| RXD[2] | DOUT[4] | RXD[2] |
| RXD[3] | DOUT[5] | RXD[3] |
| RXD[4] | DOUT[6] | RXD[4] |
| RXD[5] | DOUT[7] | RXD[5] |
| RXD[6] | DOUT[8] | RXD[6] |
| RXD[7] (MSB) | DOUT[9] | RXD[7] |

When the 10B/8B decoder is bypassed (DECMODE = LOW), the framed 10-bit character is presented to the receiver output register, along with a status output (COMDET) indicating if the

character in the output register is one of the selected framing characters. The bit usage and mapping of the external signals to the raw 10B transmission character is shown in Table 14.

Table 14. Decoder Bypass Mode (DECMODE = LOW)

| Signal Name | Bus Weight | 10B Name |
|---------------|----------------|----------|
| RXST[2] (LSB) | COMDET | |
| RXST[1] | 2 ⁰ | a |
| RXST[0] | 2 ¹ | b |
| RXD[0] | 2 ² | c |
| RXD[1] | 2 ³ | d |
| RXD[2] | 2 ⁴ | e |
| RXD[3] | 2 ⁵ | i |
| RXD[4] | 2 ⁶ | f |
| RXD[5] | 2 ⁷ | g |
| RXD[6] | 2 ⁸ | h |
| RXD[7] (MSB) | 2 ⁹ | j |

The COMDET output is HIGH when the character in the output register contains the selected framing character at the proper character boundary, and LOW for all other bit combinations.

When the low-latency framer and half-rate receive port clocking is also enabled (RFMODE = LOW, RXRATE = HIGH, and RXCKSEL = MID), the framer will stretch the recovered clock to the nearest 20-bit boundary such that the rising edge of RXCLK+ occurs when COMDET = HIGH in the output register.

When the Cypress or alternate-mode framer is enabled and half-rate receive port clocking is also enabled (RFMODE ≠ LOW and RXRATE = HIGH), the output clock is not modified when framing is detected, but a single pipeline stage may be added or subtracted from the data stream by the framer logic such that the rising edge of RXCLK+ occurs when COMDET = HIGH in the output register. This adjustment only occurs when the framer is enabled (RFEN = HIGH). When the framer is disabled, the clock boundaries are not adjusted, and COMDET may be asserted during the rising edge of RXCLK- (if an odd number of characters were received following the initial framing).

Note

23. The RXOP output is also driven from the Output Register, but its interpretation is under the separate control of PARCTL.

Parity Generation

In addition to the eleven data and status bits that are presented, an RXOP parity output is also available. This allows the CYP(V)15G0101DXB to support ODD parity generation. To handle a wide range of system environments, the CYP(V)15G0101DXB supports different forms of parity generation (in addition to no parity). When the decoder is enabled (DECMODE \neq LOW), parity can be generated on

- the RXD[7:0] character
- the RXD[7:0] character and RXST[2:0] status.

When the decoder is bypassed (DECMODE = LOW), parity can be generated on

- the RXD[7:0] and RXST[1:0] bits
- the RXD[7:0] and RXST[2:0] bits.

These modes differ in the number of bits which are included in the parity calculation. For all cases, only ODD parity is provided which ensures that at least one bit of the data bus is always a logic-1. Those bits covered by parity generation are listed in [Table 15](#).

Parity generation is enabled through the 3-level select PARCTL input. When PARCTL = LOW, parity checking is disabled, and the RXOP output is disabled (high Z).

Table 15. Output Register Parity Generation

| Signal Name | Receive Parity Generate Mode (PARCTL) | | | |
|-------------|---------------------------------------|---------------|--------------------|-------------------|
| | LOW ^[24] | MID | | HIGH |
| | | DECMODE = LOW | DECMODE \neq LOW | |
| RXST[2] | | | | X ^[25] |
| RXST[1] | | X | | X |
| RXST[0] | | X | | X |
| RXD[0] | | X | X | X |
| RXD[1] | | X | X | X |
| RXD[2] | | X | X | X |
| RXD[3] | | X | X | X |
| RXD[4] | | X | X | X |
| RXD[5] | | X | X | X |
| RXD[6] | | X | X | X |
| RXD[7] | | X | X | X |

When PARCTL = MID (open) and the decoder is enabled (DECMODE \neq LOW), ODD parity is generated for the received and decoded character in the RXD[7:0] signals and is presented on the RXOP output.

When PARCTL = MID (open) and the decoder is bypassed (DECMODE = LOW), ODD parity is generated for the received and decoded character in the RXD[7:0] and RXST[1:0] bit positions.

When PARCTL = HIGH, ODD parity is generated for the TXD[7:0] and the RXST[2:0] status bits.

Receive Status Bits

When the 10B/8B decoder is enabled (DECMODE \neq LOW), each character presented at the output register includes three associated status bits. These bits are used to identify

- if the contents of the data bus are valid
- the type of character present
- the state of receive BIST operations (regardless of the state of DECMODE)
- character violations.

These conditions normally overlap; for example, a valid data character received with incorrect running disparity is not reported as a valid data character. It is instead reported as a decoder violation of some specific type. This implies a hierarchy or priority level to the various status bit combinations. The hierarchy and value of each status is listed in [Table 16](#).

Within these status decodes, there are three forms of status reporting. The two normal or data status reporting modes (Type A and Type B) are selectable through the RXMODE input. These status types allow compatibility with legacy systems, while allowing full reporting in new systems. The third status type is used for reporting receive BIST status and progress.

BIST Status State Machine

When the receive path is enabled to look for and compare the received data stream with the BIST pattern, the RXST[2:0] bits identify the present state of the BIST compare operation.

The BIST state machine has multiple states, as shown in [Figure 2 on page 24](#) and [Table 16](#). When the receive PLL detects an out-of-lock condition, the BIST state is forced to the Start-of-BIST state, regardless of the present state of the BIST state machine. If the number of detected errors ever exceeds the number of valid matches by greater than 16, the state machine is forced to the WAIT_FOR_BIST state where it monitors the interface for the first character (D0.0) of the next BIST sequence. Also, if the elasticity buffer ever hits and overflow/underflow condition, the status is forced to the BIST_START until the buffer is re-centered (approximately nine character periods).

To ensure compatibility between the source and destination systems when operating in BIST, the sending and receiving ends of the BIST sequence must use the same clock setup (RXCKSEL = MID or RXCKSEL = LOW).

Notes

24. Receive path parity output driver (RXOP) is disabled (high Z) when PARCTL = LOW.

25. When the decoder is bypassed (DECMODE = LOW) and BIST is not enabled (Receive BIST latch output is HIGH), RXST[2] is driven to a logic-0, except when the character in the output buffer is a framing character.

JTAG Support

The CYP(V)15G0101DXB contains a JTAG port to allow system level diagnosis of device interconnect. Of the available JTAG modes, only boundary scan is supported. This capability is present only on the LVTTTL inputs, LVTTTL outputs and the REFCLK± clock input. The high-speed serial inputs and outputs are not part of the JTAG test chain.

JTAG ID

The JTAG device ID for the CYP(V)15G0101DXB is "1C804069"x.

3-Level Select Inputs

Each 3-level select input reports as two bits in the scan register. These bits report the LOW, MID, and HIGH state of the associated input as 00, 10, and 11, respectively.

Table 16. Receive Character Status Bits

| RXST[2:0] | Priority | Description | | |
|-----------|----------|--|---------------|--|
| | | Type-A Status | Type-B Status | Receive BIST Status (Receive BIST = Enabled) |
| 000 | 7 | Normal character received. The valid data character on the output bus meets all the formatting requirements of data characters listed in Table 20 . | | BIST data compare. Character compared correctly |
| 001 | 7 | Special code detected. The valid special character on the output bus meets all the formatting requirements of the special code characters listed in Table 21 , but is not the presently selected framing character or a decoder violation indication. | | BIST command compare. Character compared correctly |
| 010 | 2 | Receive elasticity buffer Underrun/Overrun error. The receive buffer was not able to add/drop a K28.5 or framing character. | RESERVED | BIST last good. Last character of BIST sequence detected and valid. |
| 011 | 5 | Framing character detected. This indicates that a character matching the patterns identified as a framing character (as selected by FRAMCHAR) was detected. The decoded value of this character is present on the output bus. | | RESERVED |
| 100 | 4 | Codeword violation. The character on the output bus is a C0.7. This indicates that the received character cannot be decoded into any valid character. | | BIST last bad. Last character of BIST sequence detected invalid. |
| 101 | 1 | PLL out of lock. This indicates a PLL out of lock condition. | | BIST start. Receive BIST is enabled on this channel, but character compares have not yet commenced. This also indicates a PLL out of lock condition, and elasticity buffer overflow/underflow conditions. |
| 110 | 6 | Running disparity error. The character on the output bus is a C4.7, C1.7, or C2.7. | | BIST error. While comparing characters, a mismatch was found in one or more of the decoded character bits. |
| 111 | 3 | RESERVED | | BIST wait. The receiver is comparing characters. but has not yet found the start of BIST character to enable the LFSR. |

Figure 2. Receive BIST State Machine

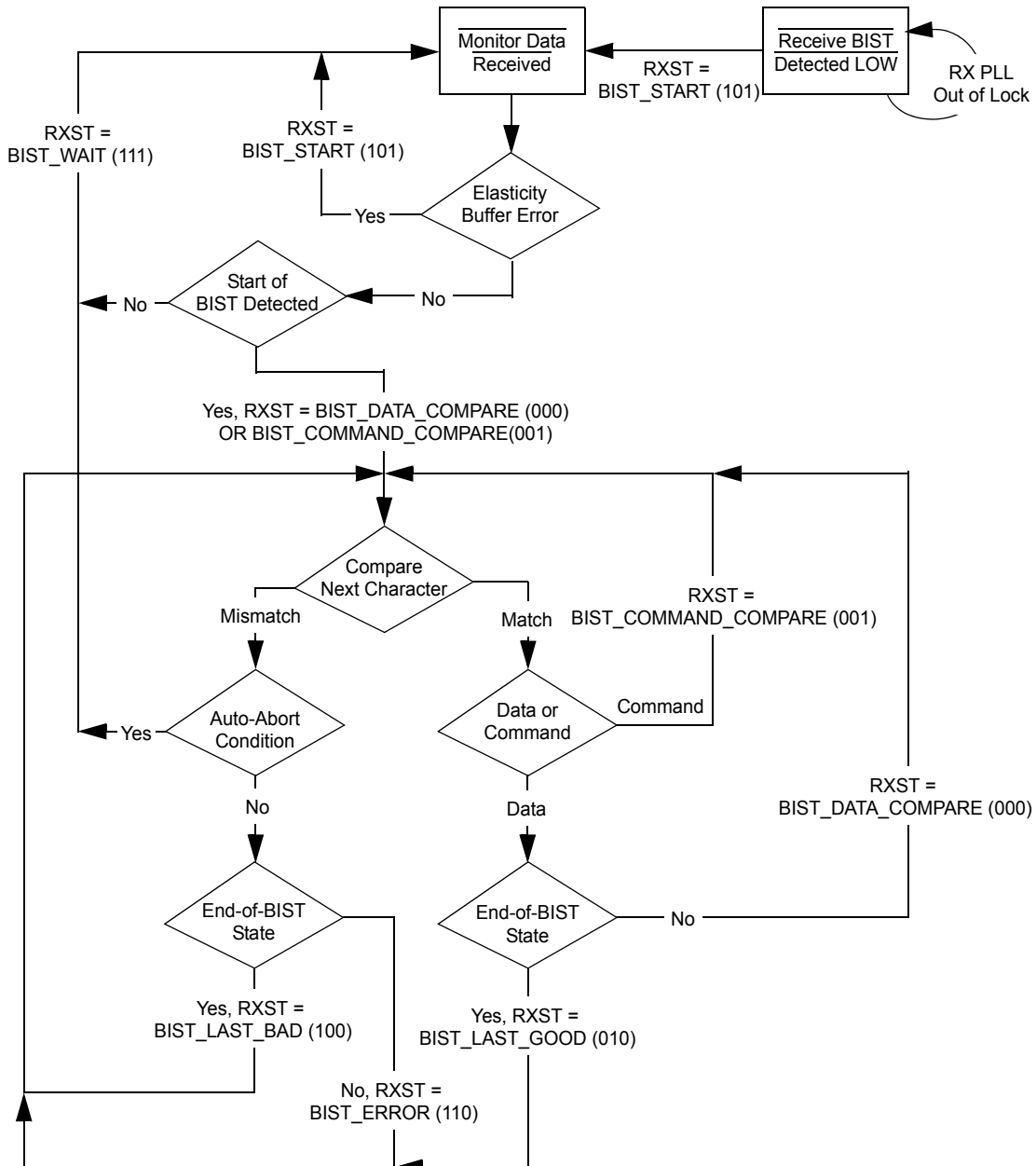

Maximum Ratings

Exceeding maximum ratings may shorten the useful life of the device. User guidelines are not tested.

| | |
|---|----------------------------|
| Storage temperature | -65 °C to +150 °C |
| Ambient temperature with power applied | -55 °C to +125 °C |
| Supply voltage to ground potential | -0.5 V to +3.8 V |
| DC voltage applied to LVTTTL outputs in high Z State..... | -0.5 V to $V_{CC} + 0.5$ V |
| Output current into LVTTTL outputs (LOW)..... | 60 mA |
| DC input voltage | -0.5 V to $V_{CC} + 0.5$ V |

Static discharge voltage..... > 2000 V
 (per MIL-STD-883, method 3015)

Latch-up current

Power-up Requirements

The CYP(V)15G0101DXB requires one power-supply. The voltage on any input or I/O pin cannot exceed the power pin during power-up.

Operating Range

| Range | Ambient Temperature | V_{CC} |
|------------|---------------------|-------------|
| Commercial | 0 °C to +70 °C | +3.3 V ± 5% |
| Industrial | -40 °C to +85 °C | +3.3 V ± 5% |

DC Electrical Characteristics

Over the Operating Range

| Parameter | Description | Test Conditions | Min | Max | Unit |
|--|--|--|----------------------|----------------------|------|
| LVTTTL-compatible Outputs | | | | | |
| V_{OHT} | Output HIGH voltage | $I_{OH} = -4$ mA, $V_{CC} = \text{Min}$ | 2.4 | V_{CC} | V |
| V_{OLT} | Output LOW voltage | $I_{OL} = 4$ mA, $V_{CC} = \text{Min}$ | 0 | 0.4 | V |
| I_{OST} | Output short circuit current | $V_{OUT} = 0V^{[26]}$ | -20 | -100 | mA |
| I_{OZL} | High Z output leakage current | | -20 | 20 | µA |
| LVTTTL-compatible Inputs | | | | | |
| V_{IHT} | Input HIGH voltage | | 2.0 | $V_{CC} + 0.3$ | V |
| V_{ILT} | Input LOW voltage | | -0.5 | 0.8 | V |
| I_{IHT} | Input HIGH current | REFCLK Input, $V_{IN} = V_{CC}$ | - | 1.5 | mA |
| | | Other Inputs, $V_{IN} = V_{CC}$ | - | +40 | µA |
| I_{ILT} | Input LOW current | REFCLK Input, $V_{IN} = 0.0$ V | - | -1.5 | mA |
| | | Other Inputs, $V_{IN} = 0.0$ V | - | -40 | µA |
| I_{IHPDT} | Input HIGH current with internal pull-down | $V_{IN} = V_{CC}$ | - | +200 | µA |
| I_{ILPUT} | Input LOW current with internal pull-up | $V_{IN} = 0.0$ V | - | -200 | µA |
| LVDIFF Inputs: REFCLK± | | | | | |
| $V_{DIFF}^{[27]}$ | Input differential voltage | | 400 | V_{CC} | mV |
| V_{IHHP} | Highest input HIGH voltage | | 1.2 | V_{CC} | V |
| V_{ILLP} | Lowest input LOW voltage | | 0.0 | $V_{CC} / 2$ | V |
| $V_{COMREF}^{[28]}$ | Common mode range | | 1.0 | $V_{CC} - 1.2$ | V |
| 3-Level Inputs | | | | | |
| V_{IHH} | 3-level input HIGH voltage | $\text{Min} \leq V_{CC} \leq \text{Max}$ | $0.87 \times V_{CC}$ | V_{CC} | V |
| V_{IMM} | 3-level input MID voltage | $\text{Min} \leq V_{CC} \leq \text{Max}$ | $0.47 \times V_{CC}$ | $0.53 \times V_{CC}$ | V |
| V_{ILL} | 3-level input LOW voltage | $\text{Min} \leq V_{CC} \leq \text{Max}$ | 0.0 | $0.13 \times V_{CC}$ | V |
| I_{IHH} | Input HIGH current | $V_{IN} = V_{CC}$ | - | 200 | µA |
| I_{IMM} | Input MID current | $V_{IN} = V_{CC}/2$ | -50 | 50 | µA |
| I_{ILL} | Input LOW current | $V_{IN} = \text{GND}$ | - | -200 | µA |
| Differential CML Serial Outputs: OUT1±, OUT2± | | | | | |
| V_{OHC} | Output HIGH voltage (V_{CC} referenced) | 100 Ω differential load | $V_{CC} - 0.5$ | $V_{CC} - 0.2$ | V |
| | | 150 Ω differential load | $V_{CC} - 0.5$ | $V_{CC} - 0.2$ | V |

Notes

26. Tested one output at a time, output shorted for less than one second, less than 10% duty cycle.

27. This is the minimum difference in voltage between the true and complement inputs required to ensure detection of a logic-1 or logic-0. A logic-1 exists when the true (+) input is more positive than the complement (-) input. A logic-0 exists when the complement (-) input is more positive than true (+) input.

28. The common mode range defines the allowable range of REFCLK+ and REFCLK- when REFCLK+ = REFCLK-. This marks the zero-crossing between the true and complement inputs as the signal switches between a logic-1 and a logic-0.

DC Electrical Characteristics

Over the Operating Range (continued)

| Parameter | Description | Test Conditions | Min | Max | Unit |
|---|---|--|------------------------|------------------------|------|
| V _{OLC} | Output LOW voltage (V _{CC} referenced) | 100 Ω differential load | V _{CC} - 1.4 | V _{CC} - 0.7 | V |
| | | 150 Ω differential load | V _{CC} - 1.4 | V _{CC} - 0.7 | V |
| V _{ODIF} | Output differential voltage (OUT+) - (OUT-) | 100 Ω differential load | 450 | 900 | mV |
| | | 150 Ω differential load | 560 | 1000 | mV |
| Differential Serial Line Receiver Inputs: IN1±, IN2± | | | | | |
| V _{DIFFS} [29] | Input differential voltage (IN+) - (IN-) | | 100 | 1200 | mV |
| V _{IHE} | Highest input HIGH voltage | | - | V _{CC} | V |
| V _{ILE} | Lowest input LOW voltage | | V _{CC} - 2.0 | - | V |
| I _{IHE} | Input HIGH current | V _{IN} = V _{IHE} Max | - | 1350 | μA |
| I _{ILE} | Input LOW current | V _{IN} = V _{ILE} Min | -700 | - | μA |
| V _{COM} [30, 31] | Common mode input range | | V _{CC} - 1.95 | V _{CC} - 0.05 | V |

| Power Supply | | | Typ [33] | Max [32] | Unit |
|-----------------|---------------------------------------|------------|----------|----------|------|
| I _{CC} | Power supply current REFCLK= Max | Commercial | 390 | 500 | mA |
| | | Industrial | | 510 | mA |
| I _{CC} | Power supply current REFCLK = 125 MHz | Commercial | 390 | 500 | mA |
| | | Industrial | | 510 | mA |

AC Test Loads and Waveforms

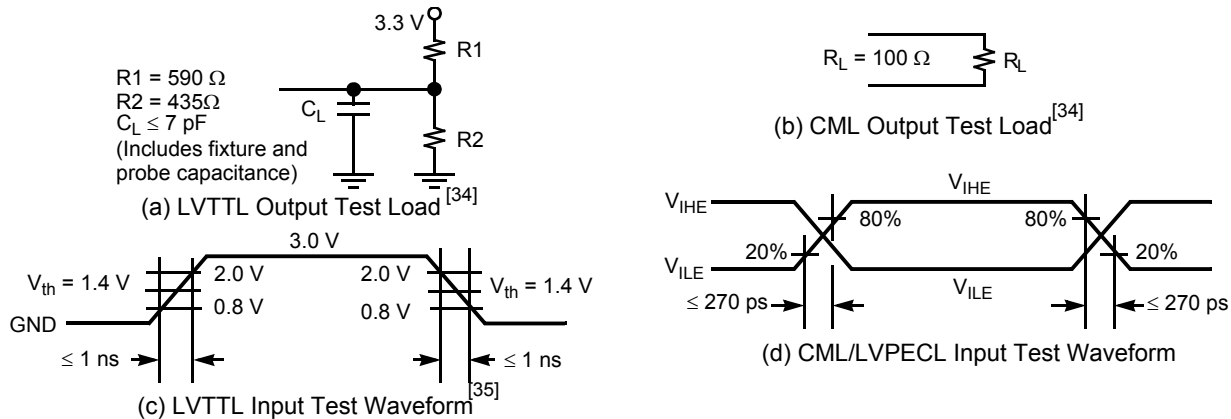

Notes

29. This is the minimum difference in voltage between the true and complement inputs required to ensure detection of a logic-1 or logic-0. A logic-1 exists when the true (+) input is more positive than the complement (-) input. A logic-0 exists when the complement (-) input is more positive than true (+) input.
30. The common mode range defines the allowable range of INPUT+ and INPUT- when INPUT+ = INPUT-. This marks the zero-crossing between the true and complement inputs as the signal switches between a logic-1 and a logic-0.
31. Not applicable for AC-coupled interfaces. For AC-coupled interfaces, V_{DIFFS} requirement still needs to be satisfied.
32. Maximum I_{CC} is measured with V_{CC} = MAX, with all Serial Drivers enabled, parallel outputs unloaded, sending a alternating 01 pattern to the Serial Input Receiver.
33. Typical I_{CC} is measured under similar conditions except with V_{CC} = 3.3V, T_A = 25°C, parallel outputs unloaded, RXCKSEL = MID, and with one Serial Line Driver sending a continuous alternating 01 pattern to the Serial Input Receiver.
34. Cypress uses constant current (ATE) load configurations and forcing functions. This figure is for reference only. 5pF differential load reflects tester capacitance, and is recommended at low data rates only.
35. The LVTTTL switching threshold is 1.4V. All timing references are made relative to the point where the signal edges crosses this threshold voltage.

CYP(V)15G0101DXB AC Characteristics

Over the Operating Range

| Parameter | Description | Min | Max | Unit |
|--|--|----------------------|--------|------|
| Transmitter LVTTTL Switching Characteristics | | | | |
| f_{TS} | TXCLK clock frequency | 19.5 | 150 | MHz |
| t_{TXCLK} | TXCLK period | 6.66 | 51.28 | ns |
| $t_{TXCLKH}^{[36]}$ | TXCLK HIGH time | 2.2 | – | ns |
| $t_{TXCLKL}^{[36]}$ | TXCLK LOW time | 2.2 | – | ns |
| $t_{TXCLKR}^{[36, 37, 38]}$ | TXCLK rise time | 0.2 | 1.7 | ns |
| $t_{TXCLKF}^{[36, 37, 38]}$ | TXCLK fall time | 0.2 | 1.7 | ns |
| t_{TXDS} | Transmit data det-up time to TXCLK \uparrow (TXCKSEL \neq LOW) | 1.7 | – | ns |
| t_{TXDH} | Transmit data hold time from TXCLK \uparrow (TXCKSEL \neq LOW) | 0.8 | – | ns |
| f_{TOS} | TXCLKO clock frequency = 1x or 2x REFCLK frequency | 19.5 | 150 | MHz |
| t_{TXCLKO} | TXCLKO period | 6.66 | 51.28 | ns |
| $t_{TXCLKOD+}$ | TXCLKO+ duty cycle with 60% HIGH time | –1.0 | +0.5 | ns |
| $t_{TXCLKOD-}$ | TXCLKO– duty cycle with 40% HIGH time | –0.5 | +1.0 | ns |
| Receiver LVTTTL Switching Characteristics | | | | |
| f_{RS} | RXCLK clock output frequency | 9.75 | 150 | MHz |
| t_{RXCLKP} | RXCLK period | 6.66 | 102.56 | ns |
| t_{RXCLKH} | RXCLK HIGH time (RXRATE = LOW) | 2.33 ^[36] | 26.64 | ns |
| | RXCLK HIGH time (RXRATE = HIGH) | 5.66 | 52.28 | ns |
| t_{RXCLKL} | RXCLK LOW time (RXRATE = LOW) | 2.33 ^[36] | 26.64 | ns |
| | RXCLK LOW time (RXRATE = HIGH) | 5.66 | 52.28 | ns |
| t_{RXCLKD} | RXCLK duty cycle centered at 50% | –1.0 | +1.0 | ns |
| $t_{RXCLKR}^{[36]}$ | RXCLK rise time | 0.3 | 1.2 | ns |
| $t_{RXCLKF}^{[36]}$ | RXCLK fall time | 0.3 | 1.2 | ns |
| $t_{RXDV-}^{[39]}$ | Status and data valid time to RXCLK (RXCKSEL = MID) | 5UI – 1.5 | – | ns |
| | Status and data valid time to RXCLK (HALF RATE RECOVERED CLOCK) | 5UI – 1.0 | – | ns |
| $t_{RXDV+}^{[39]}$ | Status and data valid time from RXCLK (RXCKSEL = MID) | 5UI – 1.8 | – | ns |
| | Status and data valid time from RXCLK (HALF RATE RECOVERED CLOCK) | 5UI – 2.3 | – | ns |
| REFCLK Switching Characteristics Over the Operating Range | | | | |
| f_{REF} | REFCLK clock frequency | 19.5 | 150 | MHz |
| t_{REFCLK} | REFCLK period | 6.6 | 51.28 | ns |
| t_{REFH} | REFCLK HIGH time (TXRATE = HIGH) | 5.9 | – | ns |
| | REFCLK HIGH time (TXRATE = LOW) | 2.9 ^[36] | – | ns |
| t_{REFL} | REFCLK LOW time (TXRATE = HIGH) | 5.9 | – | ns |
| | REFCLK LOW time (TXRATE = LOW) | 2.9 ^[36] | – | ns |
| $t_{REFD}^{[40]}$ | REFCLK duty cycle | 30 | 70 | % |
| $t_{REFR}^{[36, 37, 38]}$ | REFCLK rise time (20% – 80%) | – | 2 | ns |
| $t_{REFF}^{[36, 37, 38]}$ | REFCLK fall time (20% – 80%) | – | 2 | ns |
| t_{TREFDS} | Transmit data setup time to REFCLK (TXCKSEL = LOW) | 1.7 | – | ns |
| t_{TREFDH} | Transmit data hold time from REFCLK (TXCKSEL = LOW) | 0.8 | – | ns |

Notes

36. Tested initially and after any design or process changes that may affect these parameters, but not 100% tested.

37. The ratio of rise time to falling time must not vary by greater than 2:1.

38. For a given operating frequency, neither rise or fall specification can be greater than 20% of the clock-cycle period or the data sheet maximum time.

39. Parallel data output specifications are only valid if all inputs or outputs are loaded with similar DC and AC loads.

40. The duty cycle specification is a simultaneous condition with the t_{REFH} and t_{REFL} parameters. This means that at faster character rates the REFCLK duty cycle cannot be as large as 30%–70%.

CYP(V)15G0101DXB AC Characteristics (continued)

Over the Operating Range

| Parameter | Description | Min | Max | Unit | |
|---|---|---|-------|--------------------|------|
| $t_{RREFDA}^{[43]}$ | Receive data access time from REFCLK (RXCKSEL = LOW) | – | 9.5 | ns | |
| t_{RREFDV} | Receive data valid time from REFCLK (RXCKSEL = LOW) | 2.5 | – | ns | |
| t_{REFDV-} | Received data valid time to RXCLK (RXCKSEL = LOW) | 10UI – 4.7 | – | ns | |
| t_{REFDV+} | Received data valid time from RXCLK (RXCKSEL = LOW) | 0.5 | – | ns | |
| $t_{REFCDV-}$ | Received data valid time to RXCLKC (RXCKSEL = LOW) | 10UI – 4.3 | – | ns | |
| $t_{REFCDV+}$ | Received data valid time from RXCLKC (RXCKSEL = LOW) | –0.2 | – | ns | |
| $t_{REFRX}^{[41, 42]}$ | REFCLK frequency referenced to extracted received clock frequency | –1500 | +1500 | ppm | |
| Transmit Serial Outputs and TX PLL Characteristics | | | | | |
| t_B | Bit time | | 5100 | 666 | ps |
| $t_{RISE}^{[42]}$ | CML output rise time 20%–80% (CML test load) | SPDSEL = HIGH | 60 | 270 | ps |
| | | SPDSEL = MID | 100 | 500 | ps |
| | | SPDSEL = LOW | 180 | 1000 | ps |
| $t_{FALL}^{[42]}$ | CML output fall time 80%–20% (CML test load) | SPDSEL = HIGH | 60 | 270 | ps |
| | | SPDSEL = MID | 100 | 500 | ps |
| | | SPDSEL = LOW | 180 | 1000 | ps |
| $t_{DJ}^{[42, 44, 46]}$ | Deterministic Jitter (peak-peak) | IEEE 802.3z ^[47] | – | 25 | ps |
| $t_{RJ}^{[42, 45, 46]}$ | Random Jitter (σ) | IEEE 802.3z ^[47] | – | 11 | ps |
| t_{TXLOCK} | Transmit PLL lock to REFCLK | – | 200 | us | |
| Receive Serial Inputs and CDR PLL Characteristics | | | | | |
| t_{RXLOCK} | Receive PLL lock to input data stream (cold start) | – | 376K | UI ^[48] | |
| | Receive PLL lock to input data stream | – | 376K | UI | |
| $t_{RXUNLOCK}$ | Receive PLL unlock rate | – | 46 | UI | |
| $t_{JTOL}^{[46]}$ | Total jitter tolerance | IEEE 802.3z ^[47] | 600 | – | ps |
| $t_{DJTOL}^{[46]}$ | Deterministic jitter tolerance | IEEE 802.3z ^[47] | 370 | – | ps |
| Capacitance^[42] | | | | | |
| Parameter | Description | Test Conditions | | Max | Unit |
| C_{INTTL} | TTL input capacitance | $T_A = 25^\circ\text{C}$, $f_0 = 1\text{ MHz}$, $V_{CC} = 3.3\text{ V}$ | | 7 | pF |
| C_{INPECL} | PECL input capacitance | $T_A = 25^\circ\text{C}$, $f_0 = 1\text{ MHz}$, $V_{CC} = 3.3\text{ V}$ | | 4 | pF |

Notes

41. REFCLK has no phase or frequency relationship with the recovered clock(s) and only acts as a centering reference to reduce clock synchronization time. REFCLK must be within ± 1500 ppm ($\pm 0.15\%$) of the remote transmitter's PLL reference (REFCLK) frequency. Although transmitting to a HOTLink II receiver necessitates the frequency difference between the transmitter and receiver reference clocks to be within ± 1500 ppm, the stability of the crystal needs to be within the limits specified by the appropriate standard when transmitting to a remote receiver that is compliant to that standard. For example, to be IEEE 802.3z Gigabit Ethernet compliant, the frequency stability of the crystal needs to be within ± 100 ppm.
42. Tested initially and after any design or process changes that may affect these parameters, but not 100% tested.
43. Since this timing parameter is greater than the minimum time period of REFCLK it sets an upper limit to the frequency in which REFCLKx can be used to clock the receive data out of the output register. For predictable timing, users can use this parameter only if REFCLK period is greater than sum of t_{RREFDA} and set-up time of the upstream device. When this condition is not true, RXCLKC \pm or RXCLKA \pm (a buffered or delayed version of REFCLK when RXCKSELx = LOW) could be used to clock the receive data out of the device.
44. While sending continuous K28.5s, outputs loaded to a balanced 100 Ω load, measured at the cross point of the differential outputs over the operating range.
45. While sending continuous K28.7s, after 100,000 samples measured at the cross point of differential outputs, time referenced to REFCLK input, over the operating range.
46. Total jitter is calculated at an assumed BER of $1E - 12$. Hence: Total Jitter (t_j) = ($t_{RJ} * 14$) + t_{DJ} .
47. Also meets all Jitter Generation and Jitter Tolerance requirements as specified by SMPTE 259M, SMPTE 292M, CPRI, ESCON, FICON, Fibre Channel and DVB-ASI.
48. Receiver UI (Unit Interval) is calculated as $1/(f_{REF} * 20)$ (when RXRATE = HIGH) or $1/(f_{REF} * 10)$ (when RXRATE = LOW) if no data is being received, or $1/(f_{REF} * 20)$ (when RXRATE = HIGH) or $1/(f_{REF} * 10)$ (when RXRATE = LOW) of the remote transmitter if data is being received. In an operating link this is equivalent to t_B .

Switching Waveforms for the HOTLink II Transmitter

Transmit Interface Write Timing TXCKSEL ≠ LOW

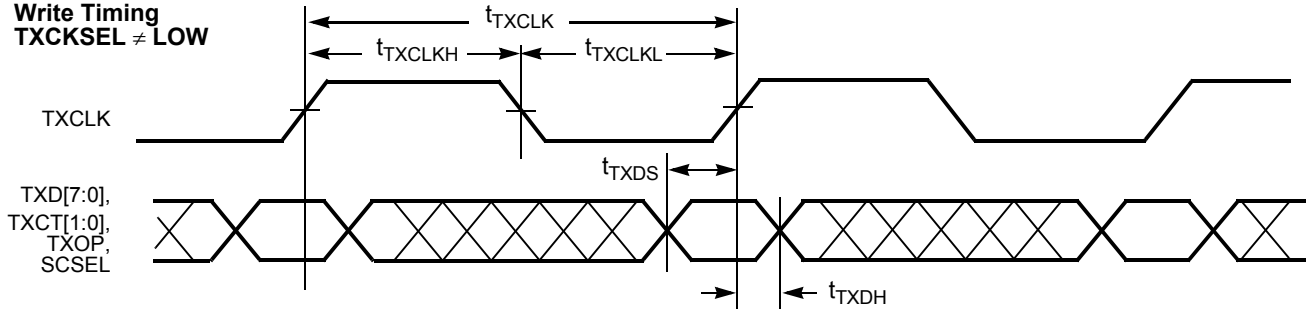

Transmit Interface Write Timing TXCKSEL = LOW TXRATE = LOW

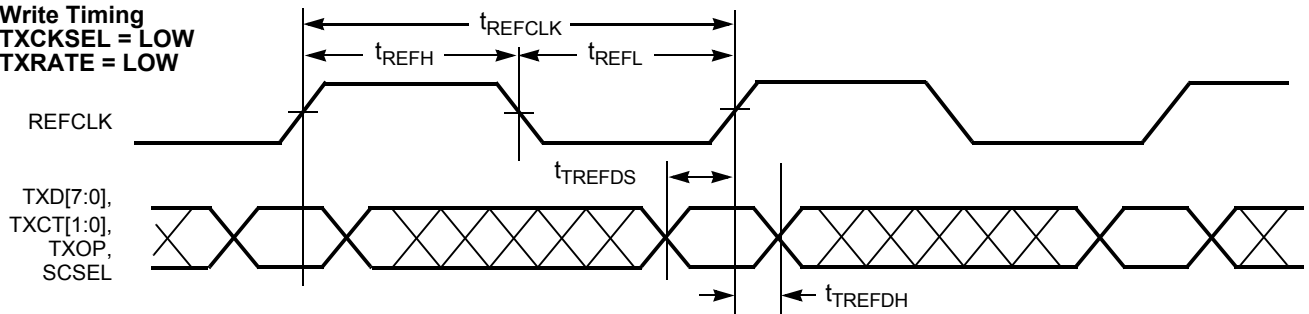

Transmit Interface Write Timing TXCKSEL = LOW TXRATE = HIGH

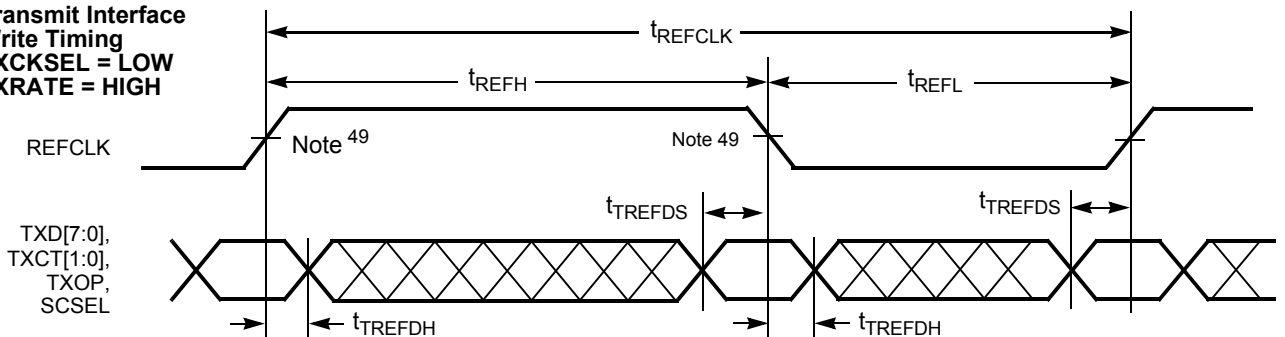

Transmit Interface TXCLKO Timing TXCKSEL = LOW TXRATE = HIGH

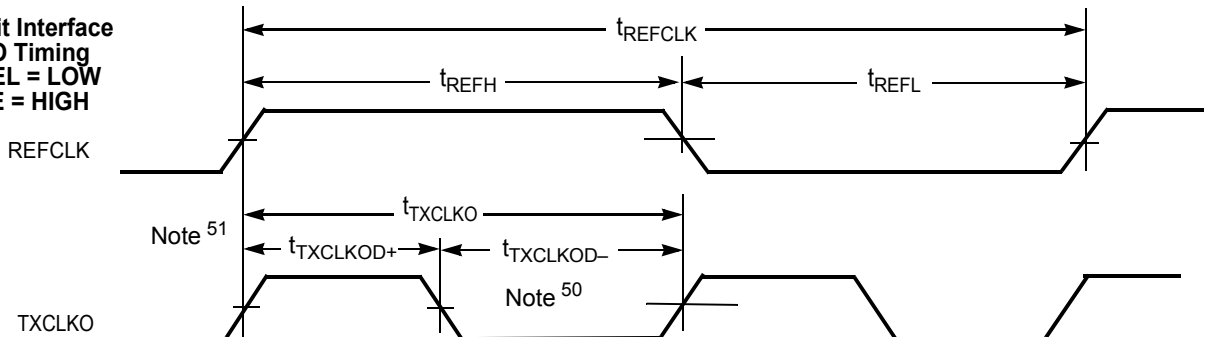

Notes

49. When REFCLK is configured for half-rate operation (TXRATE = HIGH) and data is captured using REFCLK instead of TXCLK clock (TXCKSEL = LOW), data is captured using both the rising and falling edges of REFCLK.
50. The TXCLKO output is at twice the rate of REFCLK when TXRATE = HIGH and same rate as REFCLK when TXRATE = LOW. TXCLKO does not follow the duty cycle of REFCLK.
51. The rising edge of TXCLKO output has no direct phase relationship to the REFCLK input.

**Transmit Interface
TXCLKO Timing
TXCKSEL = LOW
TXRATE = LOW**

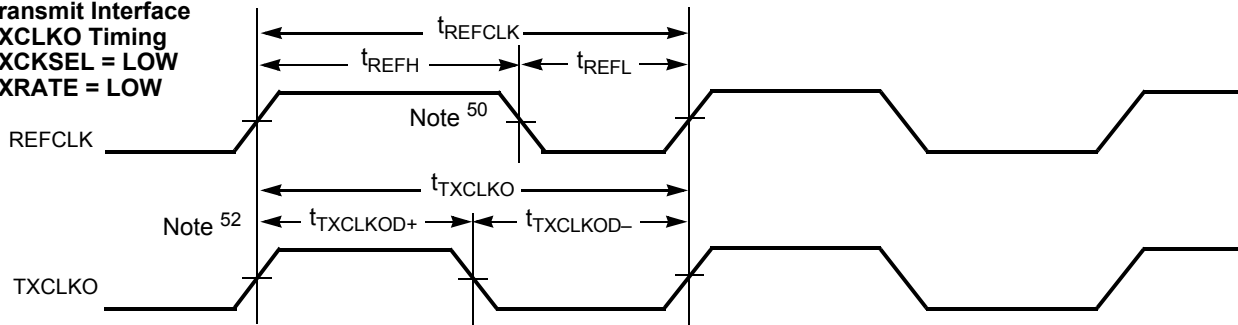

**Receive Interface
Read Timing
RXCKSEL = LOW
TXRATE = LOW**

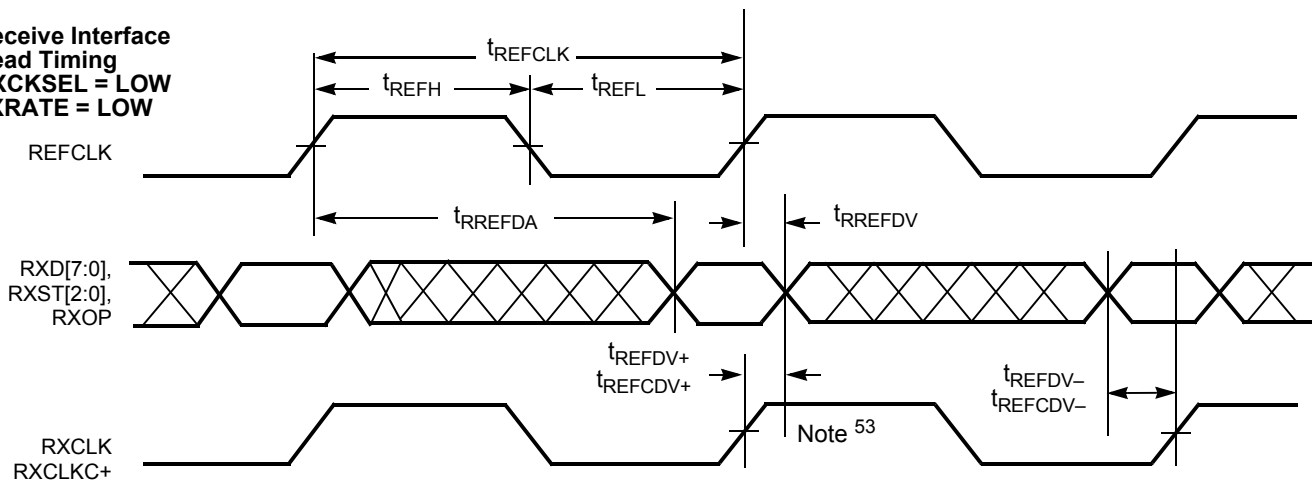

**Receive Interface
Read Timing
RXCKSEL = LOW
TXRATE = HIGH**

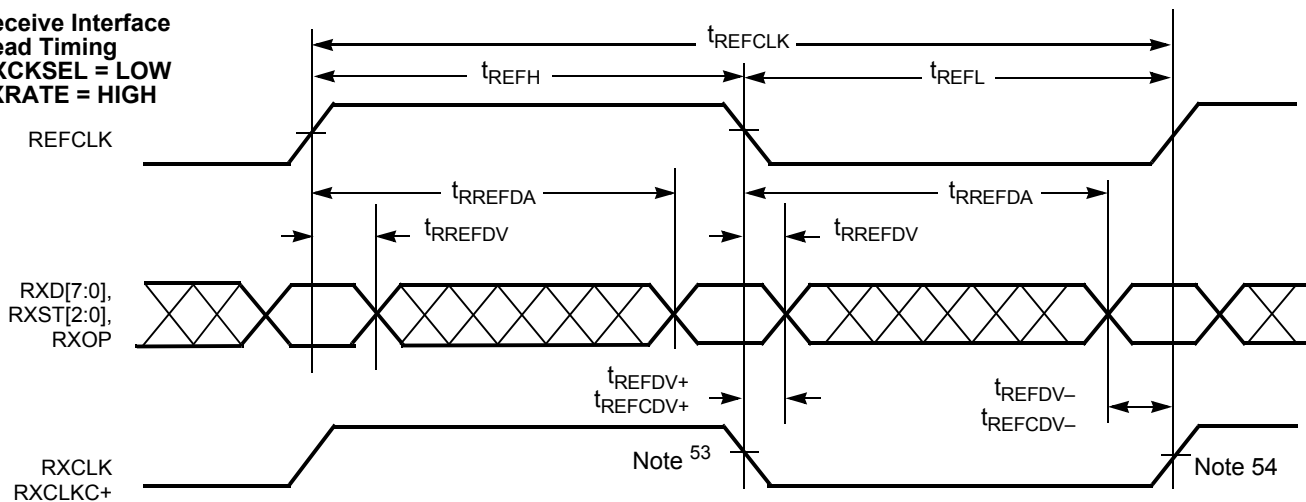

Notes

- 52. The rising edge of TXCLKO output has no direct phase relationship to the REFCLK input.
- 53. RXCLK and RXCLK+ are delayed versions of REFCLK when RXCKSEL = LOW, and are different in phase from each other.
- 54. When operated with a half-rate REFCLK, the setup and hold specifications for data relative to RXCLK are relative to both rising and falling edges of the clock output

**Receive Interface
 Read Timing
 RXCKSEL = MID
 RXRATE = LOW**

**Receive Interface
 Read Timing
 RXCKSEL = MID
 RXRATE = HIGH**

Table 17. Package Coordinate Signal Allocation

| Ball ID | Signal Name | Signal Type | Ball ID | Signal Name | Signal Type | Ball ID | Signal Name | Signal Type |
|---------|-------------|----------------|---------|-------------|----------------|---------|-------------|--------------|
| A1 | VCC | POWER | D5 | GND | GROUND | G9 | TXCLKO+ | LVTTTL OUT |
| A2 | IN2+ | CML IN | D6 | GND | GROUND | G10 | TXCLKO- | LVTTTL OUT |
| A3 | VCC | POWER | D7 | GND | GROUND | H1 | RXD[0] | LVTTTL OUT |
| A4 | OUT2- | CML OUT | D8 | TMS | LVTTTL IN PU | H2 | RXD[2] | LVTTTL OUT |
| A5 | RXMODE | 3-LEVEL SEL | D9 | TRSTZ | LVTTTL IN PU | H3 | RXD[6] | LVTTTL OUT |
| A6 | TXMODE[1] | 3-LEVEL SEL | D10 | TDI | LVTTTL IN PU | H4 | LF1 | LVTTTL OUT |
| A7 | IN1+ | CML IN | E1 | BISTLE | LVTTTL IN PU | H5 | TXCT[1] | LVTTTL IN |
| A8 | VCC | POWER | E2 | DECMODE | 3-LEVEL SEL | H6 | TXD[6] | LVTTTL IN |
| A9 | OUT1- | CML OUT | E3 | OELE | LVTTTL IN PU | H7 | TXD[3] | LVTTTL IN |
| A10 | VCC | POWER | E4 | GND | GROUND | H8 | TXCLK | LVTTTL IN PD |
| B1 | VCC | POWER | E5 | GND | GROUND | H9 | TXRST | LVTTTL IN PU |
| B2 | IN2- | CML IN | E6 | GND | GROUND | H10 | #NC | NO CONNECT |
| B3 | TDO | LVTTTL 3-S OUT | E7 | GND | GROUND | J1 | VCC | POWER |
| B4 | OUT2+ | CML OUT | E8 | TCLK | LVTTTL IN PD | J2 | RXD[3] | LVTTTL OUT |
| B5 | TXRATE | LVTTTL IN PD | E9 | RXCKSEL | 3-LEVEL SEL | J3 | RXD[7] | LVTTTL OUT |
| B6 | TXMODE[0] | 3-LEVEL SEL | E10 | TXCKSEL | 3-LEVEL SEL | J4 | RXCLK- | LVTTTL OUT |
| B7 | IN1- | CML IN | F1 | RXST[2] | LVTTTL OUT | J5 | TXCT[0] | LVTTTL IN |
| B8 | #NC | NO CONNECT | F2 | RXST[1] | LVTTTL OUT | J6 | TXD[5] | LVTTTL IN |
| B9 | OUT1+ | CML OUT | F3 | RXST[0] | LVTTTL OUT | J7 | TXD[2] | LVTTTL IN |
| B10 | VCC | POWER | F4 | GND | GROUND | J8 | TXD[0] | LVTTTL IN |
| C1 | RFEN | LVTTTL IN PD | F5 | GND | GROUND | J9 | #NC | NO CONNECT |
| C2 | LPEN | LVTTTL IN PD | F6 | GND | GROUND | J10 | VCC | POWER |
| C3 | RXLE | LVTTTL IN PU | F7 | GND | GROUND | K1 | VCC | POWER |
| C4 | RXCLKC+ | LVTTTL 3-S OUT | F8 | TXPER | LVTTTL OUT | K2 | RXD[4] | LVTTTL OUT |
| C5 | RXRATE | LVTTTL IN PD | F9 | REFCLK- | PECL IN | K3 | VCC | POWER |
| C6 | SDASEL | 3-LEVEL SEL | F10 | REFCLK+ | PECL IN | K4 | RXCLK+ | LVTTTL OUT |
| C7 | SPDSEL | 3-LEVEL SEL | G1 | RXOP | LVTTTL 3-S OUT | K5 | TXD[7] | LVTTTL IN |
| C8 | PARCTL | 3-LEVEL SEL | G2 | RXD[1] | LVTTTL OUT | K6 | TXD[4] | LVTTTL IN |
| C9 | RFMODE | 3-LEVEL SEL | G3 | RXD[5] | LVTTTL OUT | K7 | TXD[1] | LVTTTL IN |
| C10 | INSEL | LVTTTL IN | G4 | GND | GROUND | K8 | VCC | POWER |
| D1 | BOE[0] | LVTTTL IN PU | G5 | GND | GROUND | K9 | SCSEL | LVTTTL IN PD |
| D2 | BOE[1] | LVTTTL IN PU | G6 | GND | GROUND | K10 | VCC | POWER |
| D3 | FRAMCHAR | 3-LEVEL SEL | G7 | GND | GROUND | | | |
| D4 | GND | GROUND | G8 | TXOP | LVTTTL IN PU | | | |

X3.230 Codes and Notation Conventions

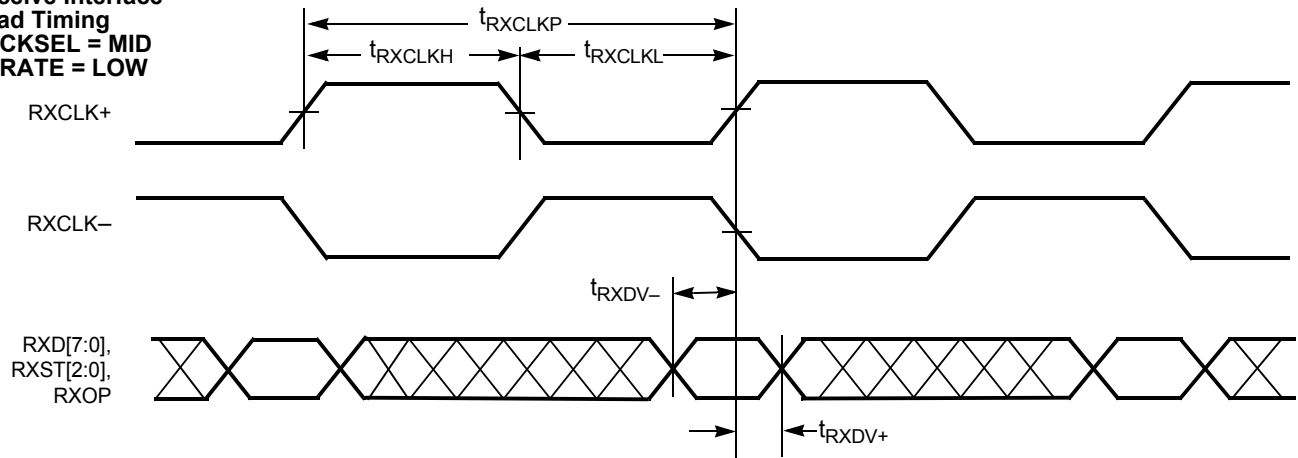
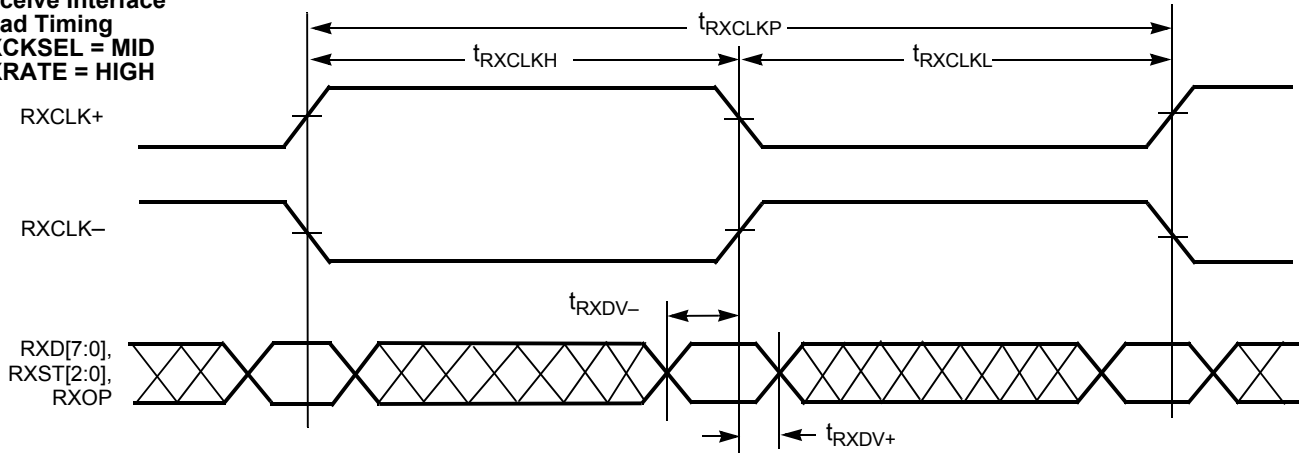
Information to be transmitted over a serial link is encoded eight bits at a time into a 10-bit Transmission Character and then sent serially, bit by bit. Information received over a serial link is collected ten bits at a time, and those Transmission Characters that are used for data characters are decoded into the correct eight-bit codes. The 10-bit Transmission Code supports all 256 eight-bit combinations. Some of the remaining Transmission Characters (Special Characters) are used for functions other than data transmission.

The primary use of a Transmission Code is to improve the transmission characteristics of a serial link. The encoding defined by the Transmission Code ensures that sufficient transitions are present in the serial bit stream to make clock recovery possible at the Receiver. Such encoding also greatly increases the likelihood of detecting any single or multiple bit errors that may occur during transmission and reception of information. In addition, some Special Characters of the Transmission Code selected by Fibre Channel Standard contain a distinct and easily recognizable bit pattern that assists the receiver in achieving character alignment on the incoming bit stream.

Notation Conventions

The documentation for the 8B/10B Transmission Code uses letter notation for the bits in an eight-bit byte. Fibre Channel Standard notation uses a bit notation of A, B, C, D, E, F, G, H for the eight-bit byte for the raw eight-bit data, and the letters a, b, c, d, e, i, f, g, h, j for encoded 10-bit data. There is a correspondence between bit A and bit a, B and b, C and c, D and d, E and e, F and f, G and g, and H and h. Bits i and j are derived, respectively, from (A,B,C,D,E) and (F,G,H).

The bit labeled A in the description of the 8B/10B Transmission Code corresponds to bit 0 in the numbering scheme of the FC-2 specification, B corresponds to bit 1, as shown below.

FC-2 bit designation—76543210
HOTLink D/Q designation—76543210
8B/10B bit designation—HGFEDCBA

To clarify this correspondence, the following example shows the conversion from an FC-2 Valid Data Byte to a Transmission Character.

```
FC-2   45H
      Bits: 7654 3210
           0100 0101
```

Converted to 8B/10B notation, note that the order of bits has been reversed):

```
Data Byte Name   D5.2
      Bits: ABCDE FGH
           10100 010
```

Translated to a transmission Character in the 8B/10B Transmission Code:

```
Bits: abcdei fghj
      101001 0101
```

Each valid Transmission Character of the 8B/10B Transmission Code has been given a name using the following convention: cxx.y, where c is used to show whether the Transmission Character is a Data Character (c is set to D, and SC/D = LOW) or a Special Character (c is set to K, and SC/D = HIGH). When

c is set to D, xx is the decimal value of the binary number composed of the bits E, D, C, B, and A in that order, and the y is the decimal value of the binary number composed of the bits H, G, and F in that order. When c is set to K, xx and y are derived by comparing the encoded bit patterns of the Special Character to those patterns derived from encoded Valid Data bytes and selecting the names of the patterns most similar to the encoded bit patterns of the Special Character.

Under the above conventions, the Transmission Character used for the examples above, is referred to by the name D5.2. The Special Character K29.7 is so named because the first six bits (abcdei) of this character make up a bit pattern similar to that resulting from the encoding of the unencoded 11101 pattern (29), and because the second four bits (fghj) make up a bit pattern similar to that resulting from the encoding of the unencoded 111 pattern (7). This definition of the 10-bit Transmission Code is based on the following references.

A.X. Widmer and P.A. Franaszek. "A DC-Balanced, Partitioned-Block, 8B/10B Transmission Code" IBM Journal of Research and Development, 27, No. 5: 440-451 (September, 1983).

U.S. Patent 4,486,739. Peter A. Franaszek and Albert X. Widmer. "Byte-Oriented DC Balanced (0.4) 8B/10B Partitioned Block Transmission Code" (December 4, 1984).

Fibre Channel Physical and Signaling Interface (ANSI X3.230-1994 ANSI FC-PH Standard).

IBM Enterprise Systems Architecture/390 ESCON I/O Interface (document number SA22-7202).

8B/10B Transmission Code

The following information describes how the tables are used for both generating valid Transmission Characters (encoding) and checking the validity of received Transmission Characters (decoding). It also specifies the ordering rules to be followed when transmitting the bits within a character and the characters within any higher-level constructs specified by a standard.

Transmission Order

Within the definition of the 8B/10B Transmission Code, the bit positions of the Transmission Characters are labeled a, b, c, d, e, i, f, g, h, j. Bit "a" is transmitted first followed by bits b, c, d, e, i, f, g, h, and j in that order.

Note that bit i is transmitted between bit e and bit f, rather than in alphabetical order.

Valid and Invalid Transmission Characters

The following tables define the valid Data Characters and valid Special Characters (K characters), respectively. The tables are used for both generating valid Transmission Characters and checking the validity of received Transmission Characters. In the tables, each Valid-Data-byte or Special-Character-code entry has two columns that represent two Transmission Characters. The two columns correspond to the current value of the running disparity. Running disparity is a binary parameter with either a negative (-) or positive (+) value.

After powering on, the Transmitter may assume either a positive or negative value for its initial running disparity. Upon transmission of any Transmission Character, the transmitter will select the proper version of the Transmission Character based on the current running disparity value, and the Transmitter

calculates a new value for its running disparity based on the contents of the transmitted character. Special Character codes C1.7 and C2.7 can be used to force the transmission of a specific Special Character with a specific running disparity as required for some special sequences in X3.230.

After powering on, the Receiver may assume either a positive or negative value for its initial running disparity. Upon reception of any Transmission Character, the Receiver decides whether the Transmission Character is valid or invalid according to the following rules and tables and calculates a new value for its Running Disparity based on the contents of the received character.

The following rules for running disparity are used to calculate the new running-disparity value for Transmission Characters that have been transmitted (Transmitter's running disparity) and that have been received (Receiver's running disparity).

Running disparity for a Transmission Character is calculated from sub-blocks, where the first six bits (abcdei) form one sub-block and the second four bits (fghj) form the other sub-block. Running disparity at the beginning of the six-bit sub-block is the running disparity at the end of the previous Transmission Character. Running disparity at the beginning of the four-bit sub-block is the running disparity at the end of the six-bit sub-block. Running disparity at the end of the Transmission Character is the running disparity at the end of the four-bit sub-block.

Running disparity for the sub-blocks is calculated as follows:

1. Running disparity at the end of any sub-block is positive if the sub-block contains more ones than zeros. It is also positive at the end of the six-bit sub-block if the six-bit sub-block is 000111, and it is positive at the end of the four-bit sub-block if the four-bit sub-block is 0011.
2. Running disparity at the end of any sub-block is negative if the sub-block contains more zeros than ones. It is also negative at the end of the six-bit sub-block if the six-bit sub-block is 111000, and it is negative at the end of the four-bit sub-block if the four-bit sub-block is 1100.
3. Otherwise, running disparity at the end of the sub-block is the same as at the beginning of the sub-block.

Use of the Tables for Generating Transmission Characters

The appropriate entry in the table is found for the Valid Data byte or the Special Character byte for which a Transmission Character is to be generated (encoded). The current value of the Transmitter's running disparity is used to select the Transmission Character from its corresponding column. For each Transmission Character transmitted, a new value of the running

disparity is calculated. This new value is used as the Transmitter's current running disparity for the next Valid Data byte or Special Character byte to be encoded and transmitted. [Table 18](#) shows naming notations and examples of valid transmission characters.

Use of the Tables for Checking the Validity of Received Transmission Characters

The column corresponding to the current value of the Receiver's running disparity is searched for the received Transmission Character. If the received Transmission Character is found in the proper column, then the Transmission Character is valid and the Data byte or Special Character code is determined (decoded). If the received Transmission Character is not found in that column, then the Transmission Character is invalid. This is called a code violation. Independent of the Transmission Character's validity, the received Transmission Character is used to calculate a new value of running disparity. The new value is used as the Receiver's current running disparity for the next received Transmission Character.

Table 18. Valid Transmission Characters

| Byte Name | Data | | Hex Value |
|-----------|-------------------------------------|-------|-----------|
| | D _{IN} or Q _{OUT} | | |
| | 765 | 43210 | |
| D0.0 | 000 | 00000 | 00 |
| D1.0 | 000 | 00001 | 01 |
| D2.0 | 000 | 00010 | 02 |
| . | . | . | . |
| . | . | . | . |
| D5.2 | 010 | 00101 | 45 |
| . | . | . | . |
| . | . | . | . |
| D30.7 | 111 | 11110 | FE |
| D31.7 | 111 | 11111 | FF |

Detection of a code violation does not necessarily show that the Transmission Character in which the code violation was detected is in error. Code violations may result from a prior error that altered the running disparity of the bit stream which did not result in a detectable error at the Transmission Character in which the error occurred. [Table 19](#) shows an example of this behavior.

Table 19. Code Violations Resulting from Prior Errors

| | RD | Character | RD | Character | RD | Character | RD |
|----------------------------|----|-------------|----|-------------|----|----------------|----|
| Transmitted data character | – | D21.1 | – | D10.2 | – | D23.5 | + |
| Transmitted bit stream | – | 101010 1001 | – | 010101 0101 | – | 111010 1010 | + |
| Bit stream after error | – | 101010 1011 | + | 010101 0101 | + | 111010 1010 | + |
| Decoded data character | – | D21.0 | + | D10.2 | + | Code Violation | + |

Table 20. Valid Data Characters (TXCTx[0] = 0, RXSTx[2:0] = 000)

| Data Byte Name | Bits | Current RD- | Current RD+ | Data Byte Name | Bits | Current RD- | Current RD+ |
|----------------|-----------|-------------|-------------|----------------|-----------|-------------|-------------|
| | HGF EDCBA | abcdei fghj | abcdei fghj | | HGF EDCBA | abcdei fghj | abcdei fghj |
| D0.0 | 000 00000 | 100111 0100 | 011000 1011 | D0.1 | 001 00000 | 100111 1001 | 011000 1001 |
| D1.0 | 000 00001 | 011101 0100 | 100010 1011 | D1.1 | 001 00001 | 011101 1001 | 100010 1001 |
| D2.0 | 000 00010 | 101101 0100 | 010010 1011 | D2.1 | 001 00010 | 101101 1001 | 010010 1001 |
| D3.0 | 000 00011 | 110001 1011 | 110001 0100 | D3.1 | 001 00011 | 110001 1001 | 110001 1001 |
| D4.0 | 000 00100 | 110101 0100 | 001010 1011 | D4.1 | 001 00100 | 110101 1001 | 001010 1001 |
| D5.0 | 000 00101 | 101001 1011 | 101001 0100 | D5.1 | 001 00101 | 101001 1001 | 101001 1001 |
| D6.0 | 000 00110 | 011001 1011 | 011001 0100 | D6.1 | 001 00110 | 011001 1001 | 011001 1001 |
| D7.0 | 000 00111 | 111000 1011 | 000111 0100 | D7.1 | 001 00111 | 111000 1001 | 000111 1001 |
| D8.0 | 000 01000 | 111001 0100 | 000110 1011 | D8.1 | 001 01000 | 111001 1001 | 000110 1001 |
| D9.0 | 000 01001 | 100101 1011 | 100101 0100 | D9.1 | 001 01001 | 100101 1001 | 100101 1001 |
| D10.0 | 000 01010 | 010101 1011 | 010101 0100 | D10.1 | 001 01010 | 010101 1001 | 010101 1001 |
| D11.0 | 000 01011 | 110100 1011 | 110100 0100 | D11.1 | 001 01011 | 110100 1001 | 110100 1001 |
| D12.0 | 000 01100 | 001101 1011 | 001101 0100 | D12.1 | 001 01100 | 001101 1001 | 001101 1001 |
| D13.0 | 000 01101 | 101100 1011 | 101100 0100 | D13.1 | 001 01101 | 101100 1001 | 101100 1001 |
| D14.0 | 000 01110 | 011100 1011 | 011100 0100 | D14.1 | 001 01110 | 011100 1001 | 011100 1001 |
| D15.0 | 000 01111 | 010111 0100 | 101000 1011 | D15.1 | 001 01111 | 010111 1001 | 101000 1001 |
| D16.0 | 000 10000 | 011011 0100 | 100100 1011 | D16.1 | 001 10000 | 011011 1001 | 100100 1001 |
| D17.0 | 000 10001 | 100011 1011 | 100011 0100 | D17.1 | 001 10001 | 100011 1001 | 100011 1001 |
| D18.0 | 000 10010 | 010011 1011 | 010011 0100 | D18.1 | 001 10010 | 010011 1001 | 010011 1001 |
| D19.0 | 000 10011 | 110010 1011 | 110010 0100 | D19.1 | 001 10011 | 110010 1001 | 110010 1001 |
| D20.0 | 000 10100 | 001011 1011 | 001011 0100 | D20.1 | 001 10100 | 001011 1001 | 001011 1001 |
| D21.0 | 000 10101 | 101010 1011 | 101010 0100 | D21.1 | 001 10101 | 101010 1001 | 101010 1001 |
| D22.0 | 000 10110 | 011010 1011 | 011010 0100 | D22.1 | 001 10110 | 011010 1001 | 011010 1001 |
| D23.0 | 000 10111 | 111010 0100 | 000101 1011 | D23.1 | 001 10111 | 111010 1001 | 000101 1001 |
| D24.0 | 000 11000 | 110011 0100 | 001100 1011 | D24.1 | 001 11000 | 110011 1001 | 001100 1001 |
| D25.0 | 000 11001 | 100110 1011 | 100110 0100 | D25.1 | 001 11001 | 100110 1001 | 100110 1001 |
| D26.0 | 000 11010 | 010110 1011 | 010110 0100 | D26.1 | 001 11010 | 010110 1001 | 010110 1001 |
| D27.0 | 000 11011 | 110110 0100 | 001001 1011 | D27.1 | 001 11011 | 110110 1001 | 001001 1001 |
| D28.0 | 000 11100 | 001110 1011 | 001110 0100 | D28.1 | 001 11100 | 001110 1001 | 001110 1001 |
| D29.0 | 000 11101 | 101110 0100 | 010001 1011 | D29.1 | 001 11101 | 101110 1001 | 010001 1001 |
| D30.0 | 000 11110 | 011110 0100 | 100001 1011 | D30.1 | 001 11110 | 011110 1001 | 100001 1001 |
| D31.0 | 000 11111 | 101011 0100 | 010100 1011 | D31.1 | 001 11111 | 101011 1001 | 010100 1001 |
| D0.2 | 010 00000 | 100111 0101 | 011000 0101 | D0.3 | 011 00000 | 100111 0011 | 011000 1100 |
| D1.2 | 010 00001 | 011101 0101 | 100010 0101 | D1.3 | 011 00001 | 011101 0011 | 100010 1100 |
| D2.2 | 010 00010 | 101101 0101 | 010010 0101 | D2.3 | 011 00010 | 101101 0011 | 010010 1100 |

Table 20. Valid Data Characters (TXCTx[0] = 0, RXSTx[2:0] = 000) (continued)

| Data Byte Name | Bits | Current RD- | Current RD+ | Data Byte Name | Bits | Current RD- | Current RD+ |
|----------------|-----------|-------------|-------------|----------------|-----------|-------------|-------------|
| | HGF EDCBA | abcdei fghj | abcdei fghj | | HGF EDCBA | abcdei fghj | abcdei fghj |
| D3.2 | 010 00011 | 110001 0101 | 110001 0101 | D3.3 | 011 00011 | 110001 1100 | 110001 0011 |
| D4.2 | 010 00100 | 110101 0101 | 001010 0101 | D4.3 | 011 00100 | 110101 0011 | 001010 1100 |
| D5.2 | 010 00101 | 101001 0101 | 101001 0101 | D5.3 | 011 00101 | 101001 1100 | 101001 0011 |
| D6.2 | 010 00110 | 011001 0101 | 011001 0101 | D6.3 | 011 00110 | 011001 1100 | 011001 0011 |
| D7.2 | 010 00111 | 111000 0101 | 000111 0101 | D7.3 | 011 00111 | 111000 1100 | 000111 0011 |
| D8.2 | 010 01000 | 111001 0101 | 000110 0101 | D8.3 | 011 01000 | 111001 0011 | 000110 1100 |
| D9.2 | 010 01001 | 100101 0101 | 100101 0101 | D9.3 | 011 01001 | 100101 1100 | 100101 0011 |
| D10.2 | 010 01010 | 010101 0101 | 010101 0101 | D10.3 | 011 01010 | 010101 1100 | 010101 0011 |
| D11.2 | 010 01011 | 110100 0101 | 110100 0101 | D11.3 | 011 01011 | 110100 1100 | 110100 0011 |
| D12.2 | 010 01100 | 001101 0101 | 001101 0101 | D12.3 | 011 01100 | 001101 1100 | 001101 0011 |
| D13.2 | 010 01101 | 101100 0101 | 101100 0101 | D13.3 | 011 01101 | 101100 1100 | 101100 0011 |
| D14.2 | 010 01110 | 011100 0101 | 011100 0101 | D14.3 | 011 01110 | 011100 1100 | 011100 0011 |
| D15.2 | 010 01111 | 010111 0101 | 101000 0101 | D15.3 | 011 01111 | 010111 0011 | 101000 1100 |
| D16.2 | 010 10000 | 011011 0101 | 100100 0101 | D16.3 | 011 10000 | 011011 0011 | 100100 1100 |
| D17.2 | 010 10001 | 100011 0101 | 100011 0101 | D17.3 | 011 10001 | 100011 1100 | 100011 0011 |
| D18.2 | 010 10010 | 010011 0101 | 010011 0101 | D18.3 | 011 10010 | 010011 1100 | 010011 0011 |
| D19.2 | 010 10011 | 110010 0101 | 110010 0101 | D19.3 | 011 10011 | 110010 1100 | 110010 0011 |
| D20.2 | 010 10100 | 001011 0101 | 001011 0101 | D20.3 | 011 10100 | 001011 1100 | 001011 0011 |
| D21.2 | 010 10101 | 101010 0101 | 101010 0101 | D21.3 | 011 10101 | 101010 1100 | 101010 0011 |
| D22.2 | 010 10110 | 011010 0101 | 011010 0101 | D22.3 | 011 10110 | 011010 1100 | 011010 0011 |
| D23.2 | 010 10111 | 111010 0101 | 000101 0101 | D23.3 | 011 10111 | 111010 0011 | 000101 1100 |
| D24.2 | 010 11000 | 110011 0101 | 001100 0101 | D24.3 | 011 11000 | 110011 0011 | 001100 1100 |
| D25.2 | 010 11001 | 100110 0101 | 100110 0101 | D25.3 | 011 11001 | 100110 1100 | 100110 0011 |
| D26.2 | 010 11010 | 010110 0101 | 010110 0101 | D26.3 | 011 11010 | 010110 1100 | 010110 0011 |
| D27.2 | 010 11011 | 110110 0101 | 001001 0101 | D27.3 | 011 11011 | 110110 0011 | 001001 1100 |
| D28.2 | 010 11100 | 001110 0101 | 001110 0101 | D28.3 | 011 11100 | 001110 1100 | 001110 0011 |
| D29.2 | 010 11101 | 101110 0101 | 010001 0101 | D29.3 | 011 11101 | 101110 0011 | 010001 1100 |
| D30.2 | 010 11110 | 011110 0101 | 100001 0101 | D30.3 | 011 11110 | 011110 0011 | 100001 1100 |
| D31.2 | 010 11111 | 101011 0101 | 010100 0101 | D31.3 | 011 11111 | 101011 0011 | 010100 1100 |
| D0.4 | 100 00000 | 100111 0010 | 011000 1101 | D0.5 | 101 00000 | 100111 1010 | 011000 1010 |
| D1.4 | 100 00001 | 011101 0010 | 100010 1101 | D1.5 | 101 00001 | 011101 1010 | 100010 1010 |
| D2.4 | 100 00010 | 101101 0010 | 010010 1101 | D2.5 | 101 00010 | 101101 1010 | 010010 1010 |
| D3.4 | 100 00011 | 110001 1101 | 110001 0010 | D3.5 | 101 00011 | 110001 1010 | 110001 1010 |
| D4.4 | 100 00100 | 110101 0010 | 001010 1101 | D4.5 | 101 00100 | 110101 1010 | 001010 1010 |
| D5.4 | 100 00101 | 101001 1101 | 101001 0010 | D5.5 | 101 00101 | 101001 1010 | 101001 1010 |
| D6.4 | 100 00110 | 011001 1101 | 011001 0010 | D6.5 | 101 00110 | 011001 1010 | 011001 1010 |

Table 20. Valid Data Characters (TXCTx[0] = 0, RXSTx[2:0] = 000) (continued)

| Data Byte Name | Bits | Current RD- | Current RD+ | Data Byte Name | Bits | Current RD- | Current RD+ |
|----------------|-----------|-------------|-------------|----------------|-----------|-------------|-------------|
| | HGF EDCBA | abcdei fghj | abcdei fghj | | HGF EDCBA | abcdei fghj | abcdei fghj |
| D7.4 | 100 00111 | 111000 1101 | 000111 0010 | D7.5 | 101 00111 | 111000 1010 | 000111 1010 |
| D8.4 | 100 01000 | 111001 0010 | 000110 1101 | D8.5 | 101 01000 | 111001 1010 | 000110 1010 |
| D9.4 | 100 01001 | 100101 1101 | 100101 0010 | D9.5 | 101 01001 | 100101 1010 | 100101 1010 |
| D10.4 | 100 01010 | 010101 1101 | 010101 0010 | D10.5 | 101 01010 | 010101 1010 | 010101 1010 |
| D11.4 | 100 01011 | 110100 1101 | 110100 0010 | D11.5 | 101 01011 | 110100 1010 | 110100 1010 |
| D12.4 | 100 01100 | 001101 1101 | 001101 0010 | D12.5 | 101 01100 | 001101 1010 | 001101 1010 |
| D13.4 | 100 01101 | 101100 1101 | 101100 0010 | D13.5 | 101 01101 | 101100 1010 | 101100 1010 |
| D14.4 | 100 01110 | 011100 1101 | 011100 0010 | D14.5 | 101 01110 | 011100 1010 | 011100 1010 |
| D15.4 | 100 01111 | 010111 0010 | 101000 1101 | D15.5 | 101 01111 | 010111 1010 | 101000 1010 |
| D16.4 | 100 10000 | 011011 0010 | 100100 1101 | D16.5 | 101 10000 | 011011 1010 | 100100 1010 |
| D17.4 | 100 10001 | 100011 1101 | 100011 0010 | D17.5 | 101 10001 | 100011 1010 | 100011 1010 |
| D18.4 | 100 10010 | 010011 1101 | 010011 0010 | D18.5 | 101 10010 | 010011 1010 | 010011 1010 |
| D19.4 | 100 10011 | 110010 1101 | 110010 0010 | D19.5 | 101 10011 | 110010 1010 | 110010 1010 |
| D20.4 | 100 10100 | 001011 1101 | 001011 0010 | D20.5 | 101 10100 | 001011 1010 | 001011 1010 |
| D21.4 | 100 10101 | 101010 1101 | 101010 0010 | D21.5 | 101 10101 | 101010 1010 | 101010 1010 |
| D22.4 | 100 10110 | 011010 1101 | 011010 0010 | D22.5 | 101 10110 | 011010 1010 | 011010 1010 |
| D23.4 | 100 10111 | 111010 0010 | 000101 1101 | D23.5 | 101 10111 | 111010 1010 | 000101 1010 |
| D24.4 | 100 11000 | 110011 0010 | 001100 1101 | D24.5 | 101 11000 | 110011 1010 | 001100 1010 |
| D25.4 | 100 11001 | 100110 1101 | 100110 0010 | D25.5 | 101 11001 | 100110 1010 | 100110 1010 |
| D26.4 | 100 11010 | 010110 1101 | 010110 0010 | D26.5 | 101 11010 | 010110 1010 | 010110 1010 |
| D27.4 | 100 11011 | 110110 0010 | 001001 1101 | D27.5 | 101 11011 | 110110 1010 | 001001 1010 |
| D28.4 | 100 11100 | 001110 1101 | 001110 0010 | D28.5 | 101 11100 | 001110 1010 | 001110 1010 |
| D29.4 | 100 11101 | 101110 0010 | 010001 1101 | D29.5 | 101 11101 | 101110 1010 | 010001 1010 |
| D30.4 | 100 11110 | 011110 0010 | 100001 1101 | D30.5 | 101 11110 | 011110 1010 | 100001 1010 |
| D31.4 | 100 11111 | 101011 0010 | 010100 1101 | D31.5 | 101 11111 | 101011 1010 | 010100 1010 |
| D0.6 | 110 00000 | 100111 0110 | 011000 0110 | D0.7 | 111 00000 | 100111 0001 | 011000 1110 |
| D1.6 | 110 00001 | 011101 0110 | 100010 0110 | D1.7 | 111 00001 | 011101 0001 | 100010 1110 |
| D2.6 | 110 00010 | 101101 0110 | 010010 0110 | D2.7 | 111 00010 | 101101 0001 | 010010 1110 |
| D3.6 | 110 00011 | 110001 0110 | 110001 0110 | D3.7 | 111 00011 | 110001 1110 | 110001 0001 |
| D4.6 | 110 00100 | 110101 0110 | 001010 0110 | D4.7 | 111 00100 | 110101 0001 | 001010 1110 |
| D5.6 | 110 00101 | 101001 0110 | 101001 0110 | D5.7 | 111 00101 | 101001 1110 | 101001 0001 |
| D6.6 | 110 00110 | 011001 0110 | 011001 0110 | D6.7 | 111 00110 | 011001 1110 | 011001 0001 |
| D7.6 | 110 00111 | 111000 0110 | 000111 0110 | D7.7 | 111 00111 | 111000 1110 | 000111 0001 |
| D8.6 | 110 01000 | 111001 0110 | 000110 0110 | D8.7 | 111 01000 | 111001 0001 | 000110 1110 |
| D9.6 | 110 01001 | 100101 0110 | 100101 0110 | D9.7 | 111 01001 | 100101 1110 | 100101 0001 |
| D10.6 | 110 01010 | 010101 0110 | 010101 0110 | D10.7 | 111 01010 | 010101 1110 | 010101 0001 |

Table 20. Valid Data Characters (TXCTx[0] = 0, RXSTx[2:0] = 000) (continued)

| Data Byte Name | Bits | Current RD- | Current RD+ | Data Byte Name | Bits | Current RD- | Current RD+ |
|----------------|-----------|-------------|-------------|----------------|-----------|-------------|-------------|
| | HGF EDCBA | abcdei fghj | abcdei fghj | | HGF EDCBA | abcdei fghj | abcdei fghj |
| D11.6 | 110 01011 | 110100 0110 | 110100 0110 | D11.7 | 111 01011 | 110100 1110 | 110100 1000 |
| D12.6 | 110 01100 | 001101 0110 | 001101 0110 | D12.7 | 111 01100 | 001101 1110 | 001101 0001 |
| D13.6 | 110 01101 | 101100 0110 | 101100 0110 | D13.7 | 111 01101 | 101100 1110 | 101100 1000 |
| D14.6 | 110 01110 | 011100 0110 | 011100 0110 | D14.7 | 111 01110 | 011100 1110 | 011100 1000 |
| D15.6 | 110 01111 | 010111 0110 | 101000 0110 | D15.7 | 111 01111 | 010111 0001 | 101000 1110 |
| D16.6 | 110 10000 | 011011 0110 | 100100 0110 | D16.7 | 111 10000 | 011011 0001 | 100100 1110 |
| D17.6 | 110 10001 | 100011 0110 | 100011 0110 | D17.7 | 111 10001 | 100011 0111 | 100011 0001 |
| D18.6 | 110 10010 | 010011 0110 | 010011 0110 | D18.7 | 111 10010 | 010011 0111 | 010011 0001 |
| D19.6 | 110 10011 | 110010 0110 | 110010 0110 | D19.7 | 111 10011 | 110010 1110 | 110010 0001 |
| D20.6 | 110 10100 | 001011 0110 | 001011 0110 | D20.7 | 111 10100 | 001011 0111 | 001011 0001 |
| D21.6 | 110 10101 | 101010 0110 | 101010 0110 | D21.7 | 111 10101 | 101010 1110 | 101010 0001 |
| D22.6 | 110 10110 | 011010 0110 | 011010 0110 | D22.7 | 111 10110 | 011010 1110 | 011010 0001 |
| D23.6 | 110 10111 | 111010 0110 | 000101 0110 | D23.7 | 111 10111 | 111010 0001 | 000101 1110 |
| D24.6 | 110 11000 | 110011 0110 | 001100 0110 | D24.7 | 111 11000 | 110011 0001 | 001100 1110 |
| D25.6 | 110 11001 | 100110 0110 | 100110 0110 | D25.7 | 111 11001 | 100110 1110 | 100110 0001 |
| D26.6 | 110 11010 | 010110 0110 | 010110 0110 | D26.7 | 111 11010 | 010110 1110 | 010110 0001 |
| D27.6 | 110 11011 | 110110 0110 | 001001 0110 | D27.7 | 111 11011 | 110110 0001 | 001001 1110 |
| D28.6 | 110 11100 | 001110 0110 | 001110 0110 | D28.7 | 111 11100 | 001110 1110 | 001110 0001 |
| D29.6 | 110 11101 | 101110 0110 | 010001 0110 | D29.7 | 111 11101 | 101110 0001 | 010001 1110 |
| D30.6 | 110 11110 | 011110 0110 | 100001 0110 | D30.7 | 111 11110 | 011110 0001 | 100001 1110 |
| D31.6 | 110 11111 | 101011 0110 | 010100 0110 | D31.7 | 111 11111 | 101011 0001 | 010100 1110 |

Table 21. Valid Special Character Codes and Sequences (TXCTx = Special Character Code or RXSTx[2:0] = 001)^[55,56]

| S.C. Code Name | S.C. Byte Name | | | | | Current RD– abcdei fghj | Current RD+ abcdei fghj |
|---|--------------------------------|----------------|--------------------------------|---------------------------|----------------|----------------------------|----------------------------|
| | Cypress | | | Alternate | | | |
| | S.C. Byte Name ^[57] | Bits HGF EDCBA | S.C. Byte Name ^[57] | Bits HGF EDCBA | | | |
| K28.0 | C0.0 (C00) | 000 00000 | C28.0 (C1C) | 000 11100 | 001111 0100 | 110000 1011 | |
| K28.1 ^[58] | C1.0 (C01) | 000 00001 | C28.1 (C3C) | 001 11100 | 001111 1001 | 110000 0110 | |
| K28.2 ^[58] | C2.0 (C02) | 000 00010 | C28.2 (C5C) | 010 11100 | 001111 0101 | 110000 1010 | |
| K28.3 | C3.0 (C03) | 000 00011 | C28.3 (C7C) | 011 11100 | 001111 0011 | 110000 1100 | |
| K28.4 ^[58] | C4.0 (C04) | 000 00100 | C28.4 (C9C) | 100 11100 | 001111 0010 | 110000 1101 | |
| K28.5 ^[58, 59] | C5.0 (C05) | 000 00101 | C28.5 (CBC) | 101 11100 | 001111 1010 | 110000 0101 | |
| K28.6 ^[58] | C6.0 (C06) | 000 00110 | C28.6 (CDC) | 110 11100 | 001111 0110 | 110000 1001 | |
| K28.7 ^[58, 60] | C7.0 (C07) | 000 00111 | C28.7 (CFC) | 111 11100 | 001111 1000 | 110000 0111 | |
| K23.7 | C8.0 (C08) | 000 01000 | C23.7 (CF7) | 111 10111 | 111010 1000 | 000101 0111 | |
| K27.7 | C9.0 (C09) | 000 01001 | C27.7 (CFB) | 111 11011 | 110110 1000 | 001001 0111 | |
| K29.7 | C10.0 (C0A) | 000 01010 | C29.7 (CFD) | 111 11101 | 101110 1000 | 010001 0111 | |
| K30.7 | C11.0 (C0B) | 000 01011 | C30.7 (CFE) | 111 11110 | 011110 1000 | 100001 0111 | |
| End of Frame Sequence | | | | | | | |
| EOFxx ^[61] | C2.1 (C22) | 001 00010 | C2.1 (C22) | 001 00010 | –K28.5,Dn.xxx0 | +K28.5,Dn.xxx1 | |
| Code Rule Violation and SVS Tx Pattern | | | | | | | |
| Exception ^[60, 62] | C0.7 (CE0) | 111 00000 | C0.7 (CE0) | 111 00000 ^[66] | 100111 1000 | 011000 0111 | |
| –K28.5 ^[63] | C1.7 (CE1) | 111 00001 | C1.7 (CE1) | 111 00001 ^[66] | 001111 1010 | 001111 1010 | |
| +K28.5 ^[64] | C2.7 (CE2) | 111 00010 | C2.7 (CE2) | 111 00010 ^[66] | 110000 0101 | 110000 0101 | |
| Running Disparity Violation Pattern | | | | | | | |
| Exception ^[65] | C4.7 (CE4) | 111 00100 | C4.7 (CE4) | 111 00100 ^[66] | 110111 0101 | 001000 1010 | |

Notes

55. All codes not shown are reserved.
56. Notation for Special Character Code Name is consistent with Fibre Channel and ESCON naming conventions. Special Character Code Name is intended to describe binary information present on I/O pins. Common usage for the name can either be in the form used for describing Data patterns (i.e., C0.0 through C31.7), or in hex notation (i.e., Cnn where nn = the specified value between 00 and FF).
57. Both the Cypress and alternate encodings may be used for data transmission to generate specific Special Character Codes. The decoding process for received characters generates Cypress codes or Alternate codes as selected by the DECMODE configuration input.
58. These characters are used for control of ESCON interfaces. They can be sent as embedded commands or other markers when not operating using ESCON protocols.
59. The K28.5 character is used for framing operations by the receiver. It is also the pad or fill character transmitted to maintain the serial link when no user data is available.
60. Care must be taken when using this Special Character code. When a K28.7(C7.0) or SVS(C0.7) is followed by a D11.x or D20.x, an alias K28.5 sync character is created. These sequences can cause erroneous framing and should be avoided while RFEN = HIGH.
61. C2.1 = Transmit either –K28.5+ or +K28.5– as determined by Current RD and modify the Transmission Character that follows, by setting its least significant bit to 1 or 0. If Current RD at the start of the following character is plus (+) the LSB is set to 0, and if Current RD is minus (–) the LSB becomes 1. This modification allows construction of X3.230 “EOF” frame delimiters wherein the second data byte is determined by the Current RD. For example, to send “EOFdt” the controller could issue the sequence C2.1–D21.4– D21.4–D21.4, and the HOTLink Transmitter will send either K28.5–D21.4–D21.4–D21.4 or K28.5–D21.5– D21.4–D21.4 based on Current RD. Likewise to send “EOFdti” the controller could issue the sequence C2.1–D10.4–D21.4–D21.4, and the HOTLink Transmitter will send either K28.5–D10.4–D21.4– D21.4 or K28.5–D10.5–D21.4– D21.4 based on Current RD. The receiver will never output this Special Character, since K28.5 is decoded as C5.0, C1.7, or C2.7, and the subsequent bytes are decoded as data.
62. C0.7 = Transmit a deliberate code rule violation. The code chosen for this function follows the normal Running Disparity rules. The receiver will only output this Special Character if the Transmission Character being decoded is not found in the tables.
63. C1.7 = Transmit Negative K28.5 (–K28.5+) disregarding Current RD. The receiver will only output this Special Character if K28.5 is received with the wrong running disparity. The receiver will output C1.7 if –K28.5 is received with RD+, otherwise K28.5 is decoded as C5.0 or C2.7.
64. C2.7 = Transmit Positive K28.5 (+K28.5–) disregarding Current RD. The receiver will only output this Special Character if K28.5 is received with the wrong running disparity. The receiver will output C2.7 if +K28.5 is received with RD–, otherwise K28.5 is decoded as C5.0 or C1.7.
65. C4.7 = Transmit a deliberate code rule violation to indicate a Running Disparity violation. The receiver will only output this Special Character if the Transmission Character being decoded is found in the tables, but Running Disparity does not match. This might indicate that an error occurred in a prior byte.
66. Supported only for data transmission. The receive status for these conditions will be reported by specific combinations of receive status bits.

Ordering Information

| Speed | Ordering Code | Package Name | Package Type | Operating Range |
|----------|--------------------|--------------|-----------------------------|-----------------|
| Standard | CYP15G0101DXB-BBXC | BB100 | Pb-free 100-ball Grid Array | Commercial |
| Standard | CYP15G0101DXB-BBXI | BB100 | Pb-free 100-ball Grid Array | Industrial |
| Standard | CYV15G0101DXB-BBXC | BB100 | Pb-free 100-ball Grid Array | Commercial |

Ordering Code Definitions

CY X15G0101 DXB - BB X X

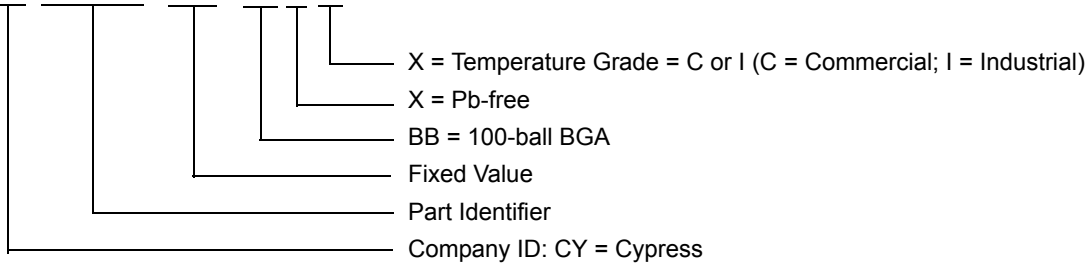

Package Diagram

Figure 3. 100-ball Thin BGA (11 × 11 × 1.4 mm) BB100 Package Outline, 51-85107

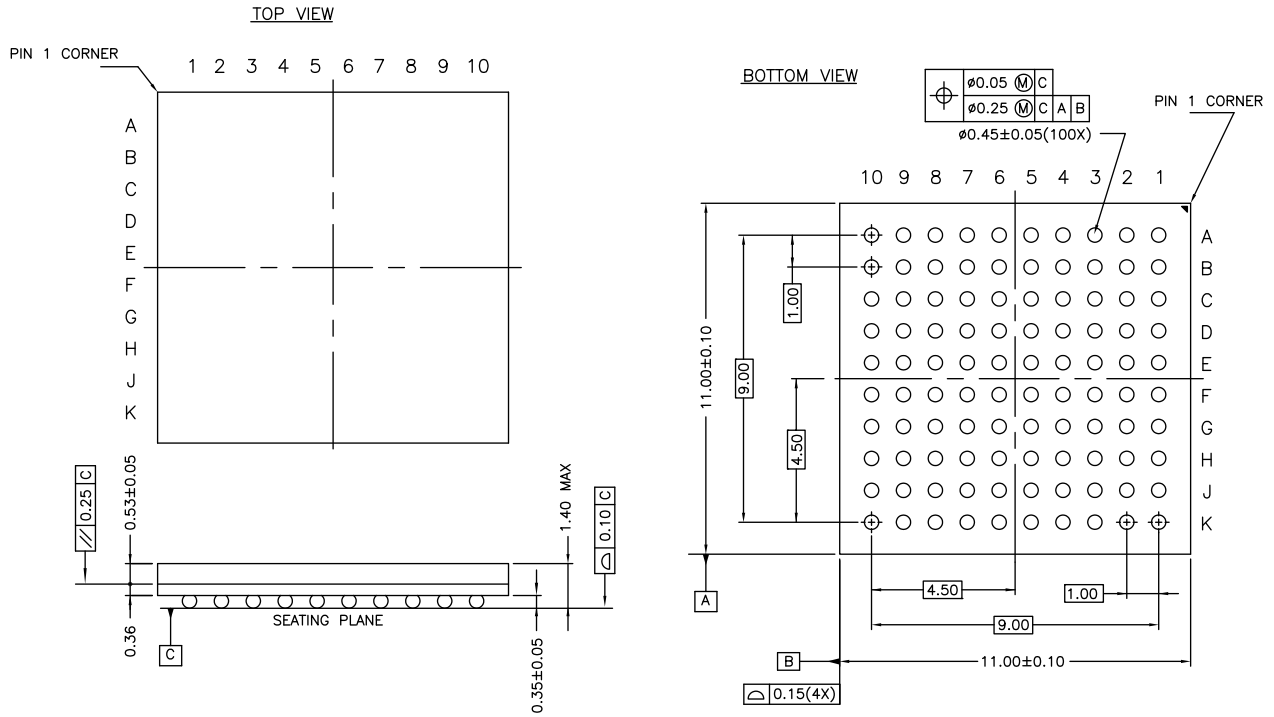

Package Weight – Refer to PMDD spec

51-85107 *E

Acronyms

Table 22. Acronyms Used in this Datasheet

| Acronym | Description |
|---------|-------------------------|
| BGA | ball grid array |
| BIST | built-in self test |
| I/O | input/output |
| JTAG | joint test action group |
| PLL | phase-locked loop |
| TMS | test mode select |
| TDO | test data out |
| TDI | test data in |

Document Conventions

Units of Measure

Table 23. Units of Measure

| Symbol | Unit of Measure |
|--------|-----------------|
| °C | degree Celsius |
| kΩ | kilohm |
| μA | microampere |
| μs | microsecond |
| mA | milliampere |
| ms | millisecond |
| mV | millivolt |
| nA | nanoampere |
| Ω | ohm |
| pF | picofarad |
| V | volt |
| W | watt |

Document History Page

| Document Title: CYP15G0101DXB/CYV15G0101DXB, Single-channel HOTLink II™ Transceiver | | | | |
|---|--------|-----------------|-----------------|---|
| Document Number: 38-02031 | | | | |
| Revision | ECN | Submission Date | Orig. of Change | Description of Change |
| ** | 113123 | 05/20/02 | TPS | New Data Sheet |
| *A | 119704 | 10/30/02 | LNLM | Changed TXPER description Changed TXCLKO description Changed RXCKSEL to include RXCLKC+ Removed disparity reference from RFMODE Removed the LOW setting for FRAMCHAR and related references Removed references to ATM transport Changed the I _{OST} boundary values Changed V _{ODIF} and V _{OLC} for CML output Changed the t _{TXCLKR} and t _{TXCLKF} min. values Changed t _{TXDS} , t _{TXDH} , t _{TREFFDS} , and t _{TREFFDH} Changed t _{REFDV-} , t _{REFCDV-} , and t _{REFCDV+} Changed the JTAG ID from 0C804069 to 1C804069 Added a section for characterization and standards compliance Changed I/O type of RXCLKC in I/O coordinates table |
| *B | 122209 | 12/28/02 | RBI | Minor Change Document Control corrected Document History Page |
| *C | 122546 | 02/13/03 | CGX | Changed Minimum tRISE/tFALL for CML Changed tRXLOCK Changed tDJ, tRJ Changed tJTOL Changed tTXLOCK Changed tRXCLKH, tRXCLKL Changed tTXCLKOD+, tTXCLKOD- Changed Power Specs Changed verbiage...Paragraph: Clock/Data Recovery Changed verbiage...Paragraph: Range Control Added Power-up Requirements |
| *D | 124994 | 04/15/03 | POT | Changed CYP15G0101DXB to CYP(V)15G0101DXB type corresponding to the Video-compliant parts Reduced the lower limit of the serial signaling rate from 200 Mbaud to 195 Mbaud and changed the associated specifications accordingly |
| *E | 128366 | 7/3/03 | PDS | Revised the value of t _{REFADV} , t _{REFADV+} and t _{REFCDV+} |
| *F | 128835 | 7/31/03 | KKV | Minor change: corrections due to editorial error - old file used for *E revision (reestablishing *D changes) |
| *G | 131898 | 12/10/03 | PDS | When TXCKSEL = MID or HIGH, TXRATE = HIGH is an invalid mode. Made appropriate changes to reflect this invalid condition Removed requirement of AC coupling for Serial I/Os for interfacing with LVPECL I/Os Changed LFI to Asynchronous output Expanded the CDR Range Controller's permissible frequency offset between incoming serial signaling rate and Reference clock from ±200-PPM to ±1500-PPM (changed parameter t _{REFRX}) |
| *H | 211461 | See ECN | KKV | Minor change: Package diagram isn't legible in pdf |
| *I | 230621 | See ECN | LAR | Updated package information in features list to reflect correct package |
| *J | 338721 | See ECN | SUA | Added CYW15G0101DXB part number for OBSAI RP3 compliance to support operating data rate upto 1540 MBaud. Made changes to reflect OBSAI RP3 and CPR compliance. Added Pb-Free Package option for all parts listed in the datasheet. Changed MBd to MBaud in SPDSEL pin description |

Document History Page *(continued)*

| Document Title: CYP15G0101DXB/CYV15G0101DXB, Single-channel HOTLink II™ Transceiver Document Number: 38-02031 | | | | |
|--|---------|-----------------|-----------------|--|
| Revision | ECN | Submission Date | Orig. of Change | Description of Change |
| *K | 2898355 | 03/24/2010 | CGX | Removed inactive parts from Ordering Information. Updated Packaging Information. |
| *L | 3053045 | 10/08/2010 | CGX | Updated Ordering Information and added Ordering Code Definitions . Added Acronyms and Document Conventions . Minor edits and updated in new template. |
| *M | 3243269 | 04/28/2011 | SAAC | Removed the following part numbers from the Ordering Information on page 40 since the parts are no longer active. (CDT 98703) a) CYP15G0101DXB-BBI b) CYV15G0101DXB-BBI c) CYW15G0101DXB-BBXI Removed all references to the part CYW15G0101DXB from the datasheet (CDT 98703). |
| *N | 3589088 | 04/17/2012 | SAAC | Removed the part number CYP15G0101DXB-BBC from the Ordering Information on page 40 as the part is no longer active. Updated Package Diagram 51-85107 (from Rev *C to *D). |
| *O | 4749016 | 04/30/2015 | YLIU | Updated Package Diagram : spec 51-85107 – Changed revision from *D to *E. Updated to new template. Completing Sunset Review. |
| *P | 5962424 | 11/09/2017 | AESATMP8 | Updated logo and Copyright. |

Sales, Solutions, and Legal Information

Worldwide Sales and Design Support

Cypress maintains a worldwide network of offices, solution centers, manufacturer's representatives, and distributors. To find the office closest to you, visit us at [Cypress Locations](#).

Products

| | |
|-------------------------------|--|
| ARM® Cortex® Microcontrollers | cypress.com/arm |
| Automotive | cypress.com/automotive |
| Clocks & Buffers | cypress.com/clocks |
| Interface | cypress.com/interface |
| Internet of Things | cypress.com/iot |
| Memory | cypress.com/memory |
| Microcontrollers | cypress.com/mcu |
| PSoC | cypress.com/psoc |
| Power Management ICs | cypress.com/pmhc |
| Touch Sensing | cypress.com/touch |
| USB Controllers | cypress.com/usb |
| Wireless Connectivity | cypress.com/wireless |

PSoC® Solutions

[PSoC 1](#) | [PSoC 3](#) | [PSoC 4](#) | [PSoC 5LP](#) | [PSoC 6](#)

Cypress Developer Community

[Forums](#) | [WICED IOT Forums](#) | [Projects](#) | [Video](#) | [Blogs](#) | [Training](#) | [Components](#)

Technical Support

cypress.com/support

© Cypress Semiconductor Corporation, 2002-2017. This document is the property of Cypress Semiconductor Corporation and its subsidiaries, including Spansion LLC ("Cypress"). This document, including any software or firmware included or referenced in this document ("Software"), is owned by Cypress under the intellectual property laws and treaties of the United States and other countries worldwide. Cypress reserves all rights under such laws and treaties and does not, except as specifically stated in this paragraph, grant any license under its patents, copyrights, trademarks, or other intellectual property rights. If the Software is not accompanied by a license agreement and you do not otherwise have a written agreement with Cypress governing the use of the Software, then Cypress hereby grants you a personal, non-exclusive, nontransferable license (without the right to sublicense) (1) under its copyright rights in the Software (a) for Software provided in source code form, to modify and reproduce the Software solely for use with Cypress hardware products, only internally within your organization, and (b) to distribute the Software in binary code form externally to end users (either directly or indirectly through resellers and distributors), solely for use on Cypress hardware product units, and (2) under those claims of Cypress's patents that are infringed by the Software (as provided by Cypress, unmodified) to make, use, distribute, and import the Software solely for use with Cypress hardware products. Any other use, reproduction, modification, translation, or compilation of the Software is prohibited.

TO THE EXTENT PERMITTED BY APPLICABLE LAW, CYPRESS MAKES NO WARRANTY OF ANY KIND, EXPRESS OR IMPLIED, WITH REGARD TO THIS DOCUMENT OR ANY SOFTWARE OR ACCOMPANYING HARDWARE, INCLUDING, BUT NOT LIMITED TO, THE IMPLIED WARRANTIES OF MERCHANTABILITY AND FITNESS FOR A PARTICULAR PURPOSE. To the extent permitted by applicable law, Cypress reserves the right to make changes to this document without further notice. Cypress does not assume any liability arising out of the application or use of any product or circuit described in this document. Any information provided in this document, including any sample design information or programming code, is provided only for reference purposes. It is the responsibility of the user of this document to properly design, program, and test the functionality and safety of any application made of this information and any resulting product. Cypress products are not designed, intended, or authorized for use as critical components in systems designed or intended for the operation of weapons, weapons systems, nuclear installations, life-support devices or systems, other medical devices or systems (including resuscitation equipment and surgical implants), pollution control or hazardous substances management, or other uses where the failure of the device or system could cause personal injury, death, or property damage ("Unintended Uses"). A critical component is any component of a device or system whose failure to perform can be reasonably expected to cause the failure of the device or system, or to affect its safety or effectiveness. Cypress is not liable, in whole or in part, and you shall and hereby do release Cypress from any claim, damage, or other liability arising from or related to all Unintended Uses of Cypress products. You shall indemnify and hold Cypress harmless from and against all claims, costs, damages, and other liabilities, including claims for personal injury or death, arising from or related to any Unintended Uses of Cypress products.

Cypress, the Cypress logo, Spansion, the Spansion logo, and combinations thereof, WICED, PSoC, CapSense, EZ-USB, F-RAM, and Traveo are trademarks or registered trademarks of Cypress in the United States and other countries. For a more complete list of Cypress trademarks, visit cypress.com. Other names and brands may be claimed as property of their respective owners.

Компания «Океан Электроники» предлагает заключение долгосрочных отношений при поставках импортных электронных компонентов на взаимовыгодных условиях!

Наши преимущества:

- Поставка оригинальных импортных электронных компонентов напрямую с производств Америки, Европы и Азии, а так же с крупнейших складов мира;
- Широкая линейка поставок активных и пассивных импортных электронных компонентов (более 30 млн. наименований);
- Поставка сложных, дефицитных, либо снятых с производства позиций;
- Оперативные сроки поставки под заказ (от 5 рабочих дней);
- Экспресс доставка в любую точку России;
- Помощь Конструкторского Отдела и консультации квалифицированных инженеров;
- Техническая поддержка проекта, помощь в подборе аналогов, поставка прототипов;
- Поставка электронных компонентов под контролем ВП;
- Система менеджмента качества сертифицирована по Международному стандарту ISO 9001;
- При необходимости вся продукция военного и аэрокосмического назначения проходит испытания и сертификацию в лаборатории (по согласованию с заказчиком);
- Поставка специализированных компонентов военного и аэрокосмического уровня качества (Xilinx, Altera, Analog Devices, Intersil, Interpoint, Microsemi, Actel, Aeroflex, Peregrine, VPT, Syfer, Eurofarad, Texas Instruments, MS Kennedy, Miteq, Cobham, E2V, MA-COM, Hittite, Mini-Circuits, General Dynamics и др.);

Компания «Океан Электроники» является официальным дистрибьютором и эксклюзивным представителем в России одного из крупнейших производителей разъемов военного и аэрокосмического назначения «JONHON», а так же официальным дистрибьютором и эксклюзивным представителем в России производителя высокотехнологичных и надежных решений для передачи СВЧ сигналов «FORSTAR».



JONHON

«JONHON» (основан в 1970 г.)

Разъемы специального, военного и аэрокосмического назначения:

(Применяются в военной, авиационной, аэрокосмической, морской, железнодорожной, горно- и нефтедобывающей отраслях промышленности)

«FORSTAR» (основан в 1998 г.)

ВЧ соединители, коаксиальные кабели, кабельные сборки и микроволновые компоненты:

(Применяются в телекоммуникациях гражданского и специального назначения, в средствах связи, РЛС, а так же военной, авиационной и аэрокосмической отраслях промышленности).



Телефон: 8 (812) 309-75-97 (многоканальный)

Факс: 8 (812) 320-03-32

Электронная почта: ocean@oceanchips.ru

Web: <http://oceanchips.ru/>

Адрес: 198099, г. Санкт-Петербург, ул. Калинина, д. 2, корп. 4, лит. А