

Description

The 87016I is a low skew, 1:16 LVCMOS/LVTTL Clock Generator. The device has four banks of four outputs and each bank can be independently selected for $\div 1$ or $\div 2$ frequency operation. Each bank also has its own power supply pins so that the banks can operate at the following different voltage levels: 3.3V, 2.5V, and 1.8V. The low impedance LVCMOS/LVTTL outputs are designed to drive 50 Ω series or parallel terminated transmission lines.

The divide select inputs, DIV_SELA:DIV_SELD, control the output frequency of each bank. The output banks can be independently selected for $\div 1$ or $\div 2$ operation. The bank enable inputs, CLK_ENA:CLK_END, support enabling and disabling each bank of outputs individually. The CLK_ENA:CLK_END circuitry has a synchronizer to prevent runt pulses when enabling or disabling the clock outputs. The master reset input, MR/OE, resets the $\div 1/\div 2$ flip flops and also controls the active and high impedance states of all outputs. This pin has an internal pull-up resistor and is normally used only for test purposes or in systems which use low power modes.

The 87016I is characterized to operate with the core at 3.3V or 2.5V and the banks at 3.3V, 2.5V, or 1.8V. Guaranteed bank, output, and part-to-part skew characteristics make the 87016I ideal for those clock applications demanding well-defined performance and repeatability.

Features

- Sixteen LVCMOS/LVTTL outputs (4 banks of 4 outputs)
- Selectable differential CLK1/CLK1 or LVCMOS/LVTTL clock input
- CLK1, CLK1 pair can accept the following differential input levels: LVPECL, LVDS, LVHSTL, SSTL, HCSL
- CLK0 supports the following input types: LVCMOS, LVTTL
- Maximum output frequency: 250MHz
- Independent bank control for $\div 1$ or $\div 2$ operation
- Independent output bank voltage settings for 3.3V, 2.5V, or 1.8V operation
- Asynchronous clock enable/disable
- Output skew: 170ps (maximum)
- Bank skew: 50ps (maximum)
- Part-to-Part Skew: 800ps (maximum)
- Supply modes:
Core/Output
3.3V/3.3V
3.3V/2.5V
3.3V/1.8V
2.5V/2.5V
2.5V/1.8V
- -40°C to 85°C ambient operating temperature
- Lead-free packaging

Block Diagram

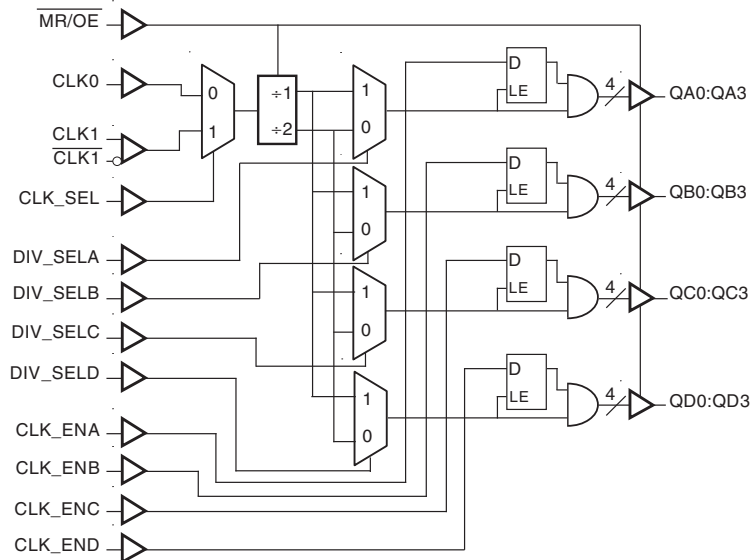

Pin Assignment

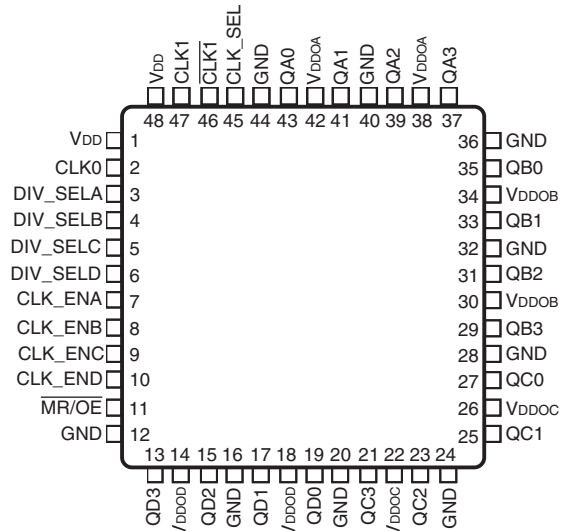

87016I

48-Lead LQFP

7mm x 7mm x 1.4mm package body

Y Package

Top View

Table 1. Pin Descriptions

Number	Name	Type		Description
1, 48	V _{DD}	Power		Positive supply pins.
2	CLK0	Input	Pulldown	Single-ended clock input. LVCMOS/LVTTL interface levels.
3	DIV_SELA	Input	Pullup	Controls frequency division for Bank A outputs. See Table 3. LVCMOS / LVTTL interface levels.
4	DIV_SELB	Input	Pullup	Controls frequency division for Bank B outputs. See Table 3. LVCMOS / LVTTL interface levels.
5	DIV_SELC	Input	Pullup	Controls frequency division for Bank C outputs. See Table 3. LVCMOS / LVTTL interface levels.
6	DIV_SELD	Input	Pullup	Controls frequency division for Bank D outputs. See Table 3. LVCMOS / LVTTL interface levels.
7	CLK_ENA	Input	Pullup	Output enable for Bank A outputs. Active HIGH. If pin is LOW, outputs drive low. LVCMOS/LVTTL interface levels. See Table 3.
8	CLK_ENB	Input	Pullup	Output enable for Bank A outputs. Active HIGH. If pin is LOW, outputs drive low. LVCMOS/LVTTL interface levels. See Table 3.
9	CLK_ENC	Input	Pullup	Output enable for Bank A outputs. Active HIGH. If pin is LOW, outputs drive low. LVCMOS/LVTTL interface levels. See Table 3.
10	CLK_END	Input	Pullup	Output enable for Bank A outputs. Active HIGH. If pin is LOW, outputs drive low. LVCMOS/LVTTL interface levels. See Table 3.
11	$\overline{\text{MR/OE}}$	Input	Pullup	Master reset. When LOW, resets the $\pm 1/\pm 2$ flip flops and sets the outputs to high impedance. LVCMOS / LVTTL interface levels.
12, 16, 20, 24, 28, 32, 36, 40, 44	GND	Power		Power supply ground
13, 15, 17, 19	QD3, QD2, QD1, QD0	Output		Bank D single-ended clock outputs. LVCMOS/LVTTL interface levels.
14, 18	V _{DDOD}	Power		Bank D output supply pins.
21, 23, 25, 27	QC3, QC2, QC1, QC0	Output		Bank C single-ended clock outputs. LVCMOS/LVTTL interface levels.
22, 26	V _{DDOC}	Power		Bank C output supply pins.
29, 31, 33, 35	QB3, QB2, QB1, QB0	Output		Bank C single-ended clock outputs. LVCMOS/LVTTL interface levels.
30, 34	V _{DDOB}	Power		Bank B output supply pins.
37, 39, 41, 43	QA3, QA2, QA1, QA0	Output		Bank A single-ended clock outputs. LVCMOS/LVTTL interface levels.
38, 42	V _{DDOA}	Power		Bank B output supply pins.
45	CLK_SEL	Input	Pulldown	Clock select input. When HIGH, selects CLK1, $\overline{\text{CLK1}}$ inputs. When LOW, selects CLK0 input. LVCMOS / LVTTL interface levels.
46	$\overline{\text{CLK1}}$	Input	Pullup	Inverting differential clock input.
47	CLK1	Input	Pulldown	Non-inverting differential clock input.

NOTE: Pullup and Pulldown refer to internal input resistors. See Table 2, *Pin Characteristics*, for typical values.

Table 2. Pin Characteristics

Symbol	Parameter	Test Conditions	Minimum	Typical	Maximum	Units
C_{IN}	Input Capacitance			4		pF
R_{PULLUP}	Input Pullup Resistor			51		k Ω
$R_{PULLDOWN}$	Input Pulldown Resistor			51		k Ω
C_{PD}	Power Dissipation Capacitance (per output); NOTE 1	$V_{DD}, V_{DDOx} = 3.465V$			18	pF
		$V_{DD}, V_{DDOx} = 2.625V$			12	pF
		$V_{DD} = 3.465V,$ $V_{DDOx} = 2.625V$			20	pF
		$V_{DD} = 3.465V,$ $V_{DDOx} = 1.89V$			30	pF
		$V_{DD} = 2.625V,$ $V_{DDOx} = 1.89V$			14	pF
R_{OUT}	Output Impedance		5	7	12	Ω

NOTE 1: V_{DDOx} denotes $V_{DDOA}, V_{DDOB}, V_{DDOC}, V_{DDOD}$.

Function Tables

Table 3. Function Table

Inputs			Outputs	
$\overline{MR/OE}$	CLK_ENx	DIV_SELx	Bank [A:D]	Qx Frequency
0	X	X	Hi-Z	N/A
1	1	0	Active	fIN/2
1	1	1	Active	fIN
1	0	X	LOW	N/A

Absolute Maximum Ratings

NOTE: Stresses beyond those listed under *Absolute Maximum Ratings* may cause permanent damage to the device. These ratings are stress specifications only. Functional operation of product at these conditions or any conditions beyond those listed in the *DC Characteristics* or *AC Characteristics* is not implied. Exposure to absolute maximum rating conditions for extended periods may affect product reliability.

Item	Rating
Supply Voltage, V_{CC}	4.6V
Inputs, V_I	-0.5V to $V_{DD} + 0.5V$
Outputs, V_O	-0.5V to $V_{DD_{Ox}} + 0.5V$
Package Thermal Impedance, θ_{JA}	47.9°C/W (0 lfpm)
Storage Temperature, T_{STG}	-65°C to 150°C

DC Electrical Characteristics

Table 4A. Power Supply DC Characteristics, $V_{DD} = 3.3V \pm 5\%$, $V_{DDOx} = 3.3V \pm 5\%$, $2.5V \pm 5\%$, $1.8V \pm 5\%$, $T_A = -40^\circ C$ to $85^\circ C$

Symbol	Parameter	Test Conditions	Minimum	Typical	Maximum	Units
V_{DD}	Positive Supply Voltage		3.135	3.3	3.465	V
V_{DDOA} , V_{DDOB} , V_{DDOC} , V_{DDOD}	Output Supply Voltage		3.135	3.3	3.465	V
			2.375	2.5	2.625	V
			1.71	1.8	1.89	V
I_{DD}	Power Supply Current				100	mA
I_{DDOA} , I_{DDOB} , I_{DDOC} , I_{DDOD}	Output Supply Current				15	mA

Table 4B. Power Supply DC Characteristics, $V_{DD} = 2.5V \pm 5\%$, $V_{DDOx} = 2.5V \pm 5\%$, $1.8V \pm 5\%$, $T_A = -40^\circ C$ to $85^\circ C$

Symbol	Parameter	Test Conditions	Minimum	Typical	Maximum	Units
V_{DD}	Positive Supply Voltage		2.375	2.5	2.625	V
V_{DDOA} , V_{DDOB} , V_{DDOC} , V_{DDOD}	Output Supply Voltage		2.375	2.5	2.625	V
			1.71	1.8	1.89	V
I_{DD}	Power Supply Current				95	mA
I_{DDOA} , I_{DDOB} , I_{DDOC} , I_{DDOD}	Output Supply Current				8	mA

Table 4C. LVCMOS/LVTTL DC Characteristics, $T_A = -40^{\circ}\text{C}$ to 85°C

Symbol	Parameter		Test Conditions	Minimum	Typical	Maximum	Units
V_{IH}	Input High Voltage		$V_{DD} = 3.465\text{V}$	2		$V_{DD} + 0.3$	V
			$V_{DD} = 2.625\text{V}$	1.7		$V_{DD} + 0.3$	V
V_{IL}	Input Low Voltage		$V_{DD} = 3.465\text{V}$	-0.3		0.8	V
			$V_{DD} = 2.625\text{V}$	-0.3		0.7	V
I_{IH}	Input High Current	CLK0, CLK_SEL	$V_{DD} = V_{IN} = 3.465\text{V}$ or 2.625V			150	μA
		CLK_EN[A:D], DIV_SEL[A:D], MR/OE	$V_{DD} = V_{IN} = 3.465\text{V}$ or 2.625V			5	μA
I_{IL}	Input Low Current	CLK0, CLK_SEL	$V_{DD} = 3.465\text{V}$ or 2.625V , $V_{IN} = 0\text{V}$	-5			μA
		CLK_EN[A:D], DIV_SEL[A:D], MR/OE	$V_{DD} = 3.465\text{V}$ or 2.625V , $V_{IN} = 0\text{V}$	-150			μA
V_{OH}	Output High Voltage; NOTE 1		$V_{DDOX} = 3.3\text{V} \pm 5\%$	2.6			V
			$V_{DDOX} = 2.5\text{V} \pm 5\%$	1.8			V
			$V_{DDOX} = 1.8\text{V} \pm 5\%$; $I_{OH} = -2\text{mA}$	$V_{DDOX} - 0.45$			V
V_{OL}	Output Low Voltage; NOTE 1		$V_{DDOX} = 3.3\text{V} \pm 5\%$			0.5	V
			$V_{DDOX} = 2.5\text{V} \pm 5\%$			0.5	V
			$V_{DDOX} = 1.8\text{V} \pm 5\%$; $I_{OH} = 2\text{mA}$			0.45	V
I_{OZL}	Output Hi-Z Current Low			-5			μA
I_{OZH}	Output Hi-Z Current High					5	μA

NOTE 1: Outputs terminated with 50Ω to $V_{DDOX}/2$. See Parameter Measurement Information, *Output Load Test Circuit diagrams*.

Table 4D. Differential DC Characteristics, $T_A = -40^{\circ}\text{C}$ to 85°C

Symbol	Parameter		Test Conditions	Minimum	Typical	Maximum	Units
I_{IH}	Input High Current	$\overline{\text{CLK1}}$	$V_{DD} = V_{IN} = 3.465\text{V}$ or 2.625V			5	μA
		CLK1	$V_{DD} = V_{IN} = 3.465\text{V}$ or 2.625V			150	μA
I_{IL}	Input Low Current	$\overline{\text{CLK1}}$	$V_{DD} = 3.465\text{V}$ or 2.625V , $V_{IN} = 0\text{V}$	-150			μA
		CLK1	$V_{DD} = 3.465\text{V}$ or 2.625V , $V_{IN} = 0\text{V}$	-5			μA
V_{PP}	Peak-to-Peak Voltage			0.15		1.3	V
V_{CMR}	Common Mode Input Voltage; NOTE 1, 2			GND + 0.5		$V_{DD} - 0.85$	V

NOTE 1: Common mode input voltage is defined as V_{IH} .

NOTE 2: For single-ended applications, the maximum input voltage for CLK1, $\overline{\text{CLK1}}$ is $V_{DD} + 0.3\text{V}$.

AC Electrical Characteristics

Table 5A. AC Characteristics, $V_{DD} = V_{DDOx} = 3.3V \pm 5\%$, $T_A = -40^{\circ}C$ to $85^{\circ}C$

Parameter	Symbol	Test Conditions	Minimum	Typical	Maximum	Units
f_{MAX}	Output Frequency				250	MHz
t_{PLH}	Propagation Delay, Low to High	CLK0; NOTE 1A	2.8	3.4	3.9	ns
		CLK1/ $\overline{CLK1}$; NOTE 1B	2.75	3.4	4.1	ns
$t_{sk(b)}$	Bank Skew; NOTE 2, 6	Measured on the Rising Edge			50	ps
$t_{sk(o)}$	Output Skew; NOTE 3, 6	Measured on the Rising Edge			170	ps
$t_{sk(pp)}$	Part-to-Part Skew; NOTE 4, 6				800	ps
t_R / t_F	Output Rise/Fall Time; NOTE 5	20% to 80%	200		700	ps
odc	Output Duty Cycle	$f < 175MHz$	45		55	%
		$f \geq 175MHz$	40		60	%
t_{EN}	Output Enable Time; NOTE 5				10	ns
t_{DIS}	Output Disable Time; NOTE 5				10	ns

All parameters measured at 250MHz unless noted otherwise.

NOTE 1A: Measured from the $V_{DD}/2$ of the input to $V_{DDOx}/2$ of the output.

NOTE 1B: Measured from the differential input crossing point to $V_{DDOx}/2$ of the output.

NOTE 2: Defined as skew within a bank with equal load conditions.

NOTE 3: Defined as skew between outputs at the same supply voltage and with equal load conditions. Measured at $V_{DDOx}/2$.

NOTE 4: Defined as skew between outputs on different devices operating at the same supply voltages and with equal load conditions. Using the same type of input on each device, the output is measured at $V_{DDOx}/2$.

NOTE 5: These parameters are guaranteed by characterization. Not tested in production.

NOTE 6: This parameter is defined in accordance with JEDEC Standard 65.

Table 5B. AC Characteristics, $V_{DD} = V_{DDOx} = 2.5V \pm 5\%$, $T_A = -40^{\circ}C$ to $85^{\circ}C$

Parameter	Symbol	Test Conditions	Minimum	Typical	Maximum	Units
f_{MAX}	Output Frequency				250	MHz
t_{PLH}	Propagation Delay, Low to High	CLK0; NOTE 1A	2.9	3.8	4.7	ns
		CLK1/ $\overline{CLK1}$; NOTE 1B	3.0	3.6	4.3	ns
$t_{sk(b)}$	Bank Skew; NOTE 2, 6	Measured on the Rising Edge			70	ps
$t_{sk(o)}$	Output Skew; NOTE 3, 6	Measured on the Rising Edge			210	ps
$t_{sk(pp)}$	Part-to-Part Skew; NOTE 4, 6				800	ps
t_R / t_F	Output Rise/Fall Time; NOTE 5	20% to 80%	150		700	ps
odc	Output Duty Cycle	$f \leq 125MHz$	40		60	%
t_{pw}	Output Pulse Width	$f > 125MHz$	$t_{Period}/2 - 800$		$t_{Period}/2 + 800$	ps
t_{EN}	Output Enable Time; NOTE 5				10	ns
t_{DIS}	Output Disable Time; NOTE 5				10	ns

For NOTES, please see above, Table 5A.

Table 5C. AC Characteristics, $V_{DD} = 3.3V \pm 5\%$, $V_{DDOx} = 2.5V \pm 5\%$, $T_A = -40^{\circ}C$ to $85^{\circ}C$

Parameter	Symbol	Test Conditions	Minimum	Typical	Maximum	Units
f_{MAX}	Output Frequency				250	MHz
t_{pLH}	Propagation Delay, Low to High	CLK0; NOTE 1A	2.9	3.5	4.0	ns
		CLK1/ $\overline{CLK1}$; NOTE 1B	3.0	3.5	4.0	ns
$t_{sk(b)}$	Bank Skew; NOTE 2, 6	Measured on the Rising Edge			50	ps
$t_{sk(o)}$	Output Skew; NOTE 3, 6	Measured on the Rising Edge			170	ps
$t_{sk(pp)}$	Part-to-Part Skew; NOTE 4, 6				800	ps
t_R / t_F	Output Rise/Fall Time; NOTE 5	20% to 80%	200		700	ps
odc	Output Duty Cycle	$f < 175MHz$	45		55	%
		$f \geq 175MHz$	40		60	%
t_{EN}	Output Enable Time; NOTE 5				10	ns
t_{DIS}	Output Disable Time; NOTE 5				10	ns

All parameters measured at 250MHz unless noted otherwise.

NOTE 1A: Measured from the $V_{DD}/2$ of the input to $V_{DDOx}/2$ of the output.

NOTE 1B: Measured from the differential input crossing point to $V_{DDOx}/2$ of the output.

NOTE 2: Defined as skew within a bank with equal load conditions.

NOTE 3: Defined as skew between outputs at the same supply voltage and with equal load conditions. Measured at $V_{DDOx}/2$.

NOTE 4: Defined as skew between outputs on different devices operating at the same supply voltages and with equal load conditions. Using the same type of input on each device, the output is measured at $V_{DDOx}/2$.

NOTE 5: These parameters are guaranteed by characterization. Not tested in production.

NOTE 6: This parameter is defined in accordance with JEDEC Standard 65.

Table 5D. AC Characteristics, $V_{DD} = 3.3V \pm 5\%$, $V_{DDOx} = 1.8V \pm 5\%$, $T_A = -40^{\circ}C$ to $85^{\circ}C$

Parameter	Symbol	Test Conditions	Minimum	Typical	Maximum	Units
f_{MAX}	Output Frequency				250	MHz
t_{pLH}	Propagation Delay, Low to High	CLK0; NOTE 1A	3.0	3.9	4.7	ns
		CLK1/ $\overline{CLK1}$; NOTE 1B	3.0	3.9	4.7	ns
$t_{sk(b)}$	Bank Skew; NOTE 2, 6	Measured on the Rising Edge			50	ps
$t_{sk(o)}$	Output Skew; NOTE 3, 6	Measured on the Rising Edge			170	ps
$t_{sk(pp)}$	Part-to-Part Skew; NOTE 4, 6				800	ps
t_R / t_F	Output Rise/Fall Time; NOTE 5	20% to 80%	200		700	ps
odc	Output Duty Cycle	$f < 175MHz$	45		55	%
		$f \geq 175MHz$	40		60	%
t_{EN}	Output Enable Time; NOTE 5				10	ns
t_{DIS}	Output Disable Time; NOTE 5				10	ns

For NOTES, please see above, Table 5C.

Table 5E. AC Characteristics, $V_{DD} = 2.5V \pm 5\%$, $V_{DDOX} = 1.8V \pm 5\%$, $T_A = -40^\circ C$ to $85^\circ C$

Parameter	Symbol	Test Conditions	Minimum	Typical	Maximum	Units
f_{MAX}	Output Frequency				250	MHz
t_{PLH}	Propagation Delay, Low to High	CLK0; NOTE 1A	3.1	4.1	5.2	ns
		CLK1/ $\overline{CLK1}$; NOTE 1B	3.0	3.9	4.7	ns
$t_{sk(b)}$	Bank Skew; NOTE 2, 6	Measured on the Rising Edge			70	ps
$t_{sk(o)}$	Output Skew; NOTE 3, 6	Measured on the Rising Edge			210	ps
$t_{sk(pp)}$	Part-to-Part Skew; NOTE 4, 6				800	ps
t_R / t_F	Output Rise/Fall Time; NOTE 5	20% to 80%	150		700	ps
odc	Output Duty Cycle	$f < 175MHz$	45		55	%
		$f \geq 175MHz$	40		60	%
t_{EN}	Output Enable Time; NOTE 5				10	ns
t_{DIS}	Output Disable Time; NOTE 5				10	ns

All parameters measured at 250MHz unless noted otherwise.

NOTE 1A: Measured from the $V_{DD}/2$ of the input to $V_{DDOX}/2$ of the output.

NOTE 1B: Measured from the differential input crossing point to $V_{DDOX}/2$ of the output.

NOTE 2: Defined as skew within a bank with equal load conditions.

NOTE 3: Defined as skew between outputs at the same supply voltage and with equal load conditions. Measured at $V_{DDOX}/2$.

NOTE 4: Defined as skew between outputs on different devices operating at the same supply voltages and with equal load conditions. Using the same type of input on each device, the output is measured at $V_{DDOX}/2$.

NOTE 5: These parameters are guaranteed by characterization. Not tested in production.

NOTE 6: This parameter is defined in accordance with JEDEC Standard 65.

Parameter Measurement Information

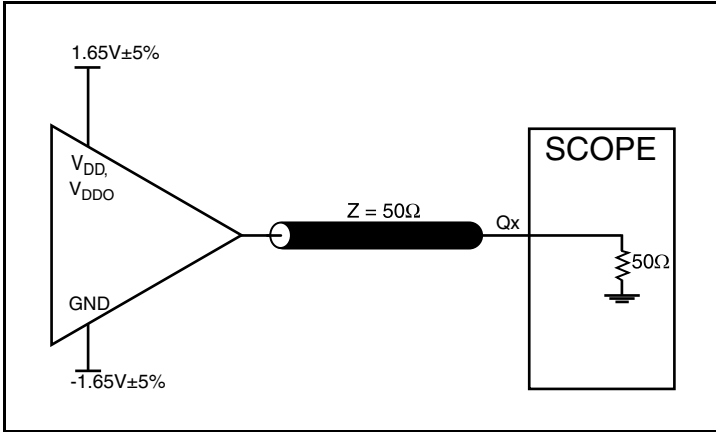

3.3V Core/3.3V LVCMOS Output Load Test Circuit

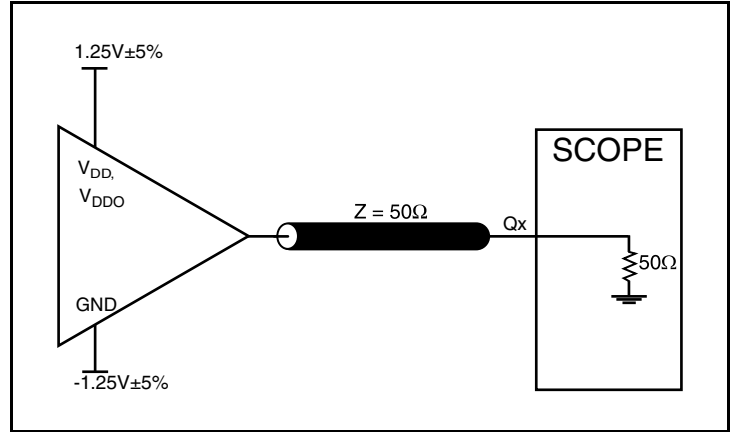

2.5V Core/2.5V LVCMOS Output Load Test Circuit

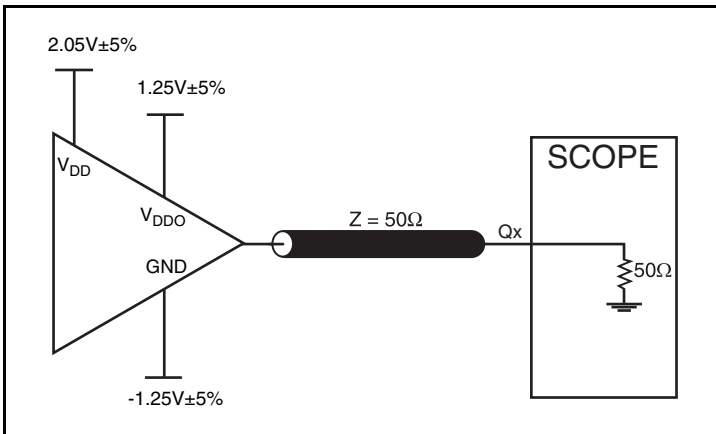

3.3V Core/2.5V LVCMOS Output Load Test Circuit

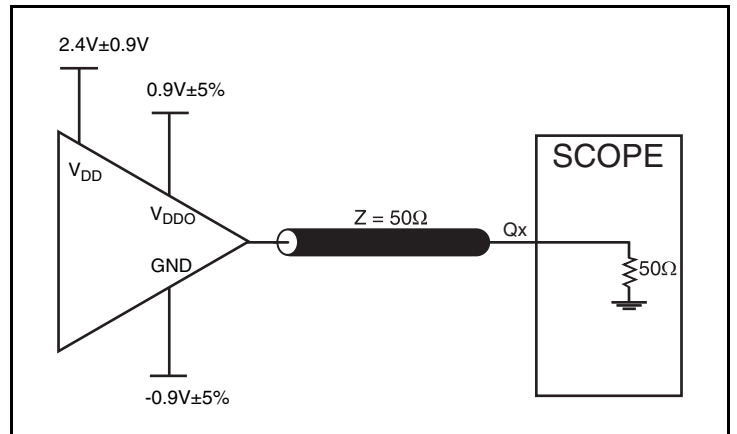

3.3V Core/1.8V LVCMOS Output Load Test Circuit

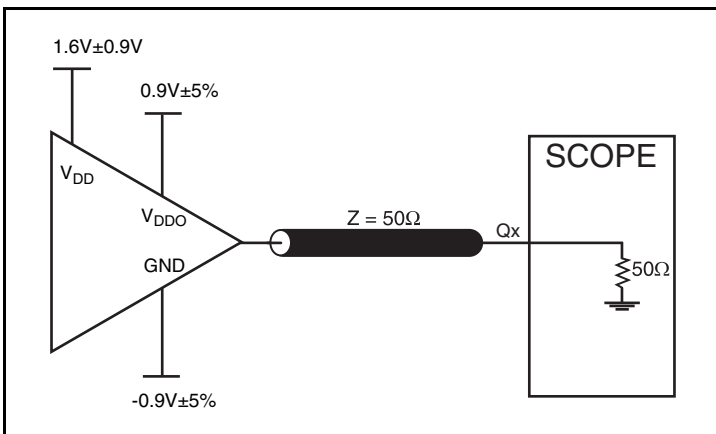

2.5V Core/1.8V LVCMOS Output Load Test Circuit

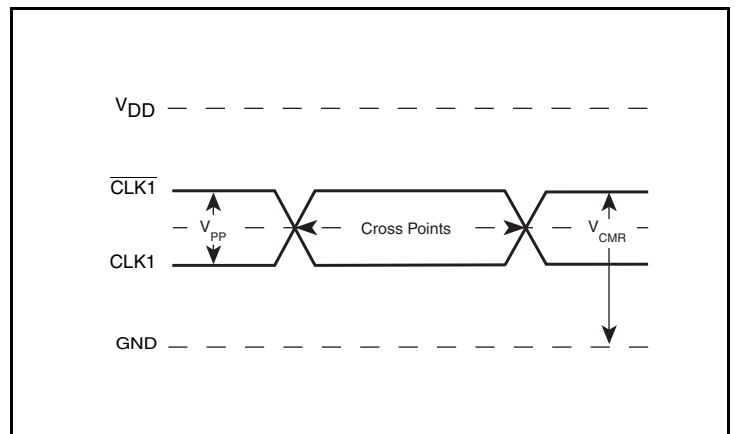

Differential Input Level

Parameter Measurement Information, continued

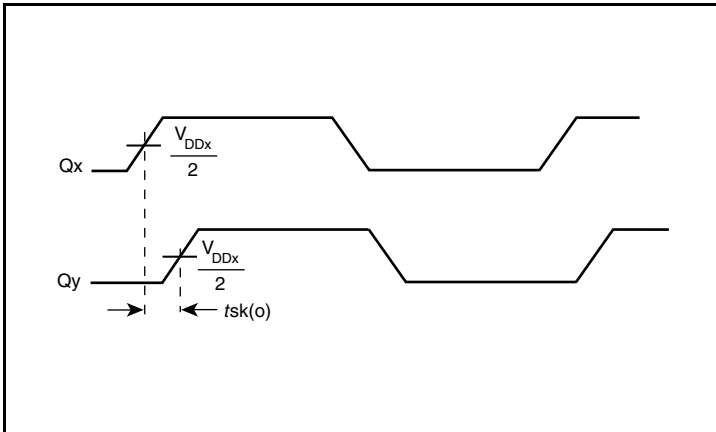

Output Skew

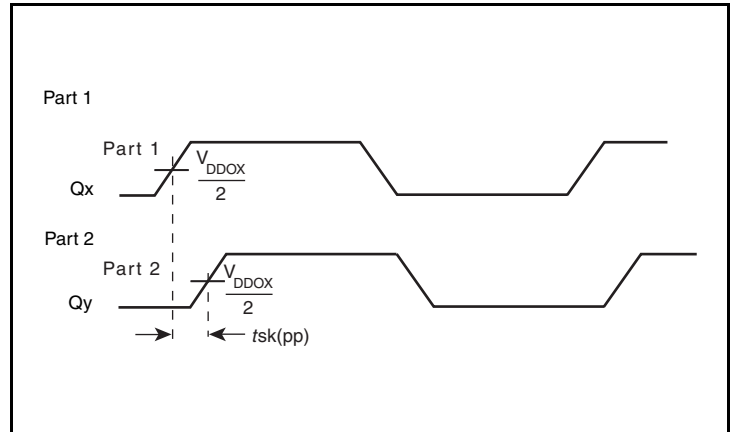

Part-to-Part Skew

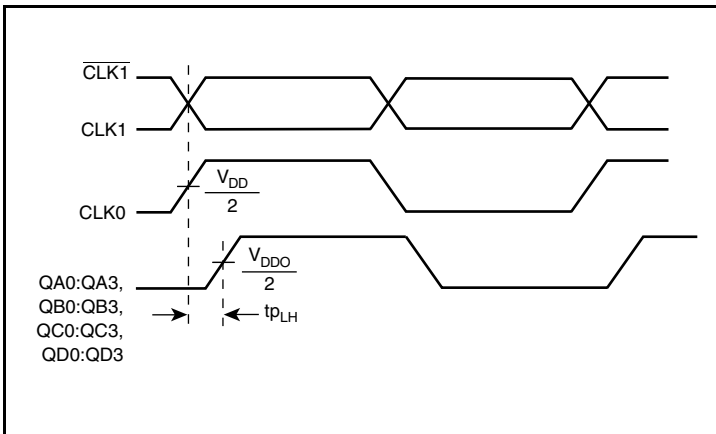

Propagation Delay

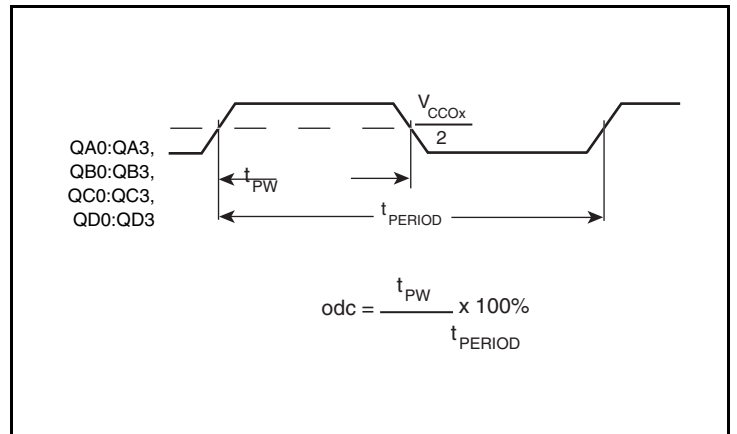

Output Duty Cycle/Pulse Width/Period

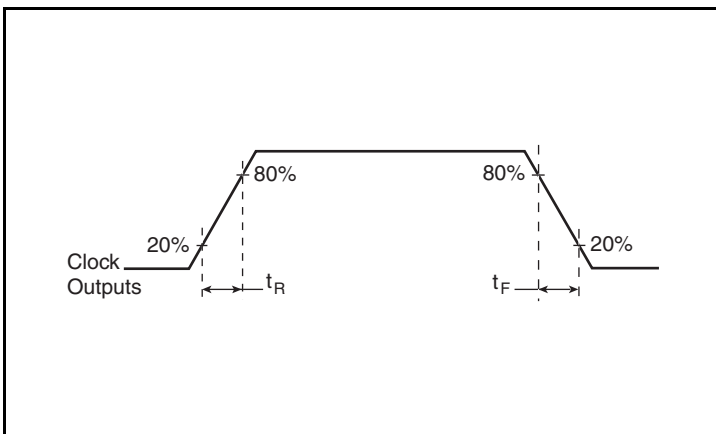

Output Rise/Fall Time

Application Information

Wiring the Differential Input to Accept Single Ended Levels

Figure 1 shows how the differential input can be wired to accept single ended levels. The reference voltage $V_{REF} = V_{DD}/2$ is generated by the bias resistors R1, R2 and C1. This bias circuit should be located as close as possible to the input pin. The ratio of R1 and R2 might need to be adjusted to position the V_{REF} in the center of the input voltage swing. For example, if the input clock swing is only 2.5V and $V_{DD} = 3.3V$, V_{REF} should be 1.25V and $R2/R1 = 0.609$.

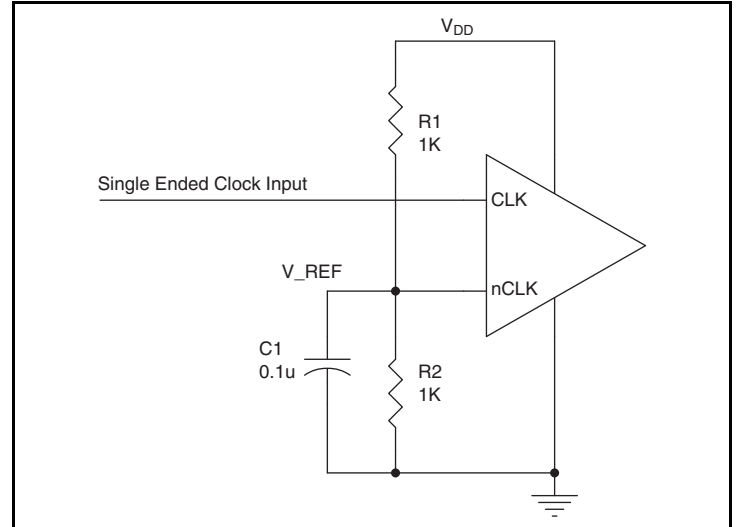

Figure 1. Single-Ended Signal Driving Differential Input

Recommendations for Unused Input and Output Pins

Inputs:

CLK/ $\overline{\text{CLK}}$ Inputs:

For applications not requiring the use of the differential input, both CLK and $\overline{\text{CLK}}$ can be left floating. Though not required, but for additional protection, a 1k Ω resistor can be tied from CLK to ground.

CLK Input:

For applications not requiring the use of a clock input, it can be left floating. Though not required, but for additional protection, a 1k Ω resistor can be tied from the CLK input to ground.

LVC MOS Control Pins:

All control pins have internal pull-ups or pull-downs; additional resistance is not required but can be added for additional protection. A 1k Ω resistor can be used.

Outputs:

LVC MOS Outputs:

All unused LVC MOS output can be left floating. There should be no trace attached.

Differential Clock Input Interface

The CLK/ $\overline{\text{CLK}}$ accepts LVDS, LVPECL, LVHSTL, SSTL, HCSL and other differential signals. Both signals must meet the V_{PP} and V_{CMR} input requirements. Figures 2A to 2E show interface examples for the CLK/ $\overline{\text{CLK}}$ input driven by the most common driver types. The input interfaces suggested here are examples only. Please consult with the

vendor of the driver component to confirm the driver termination requirements. For example, in Figure 2A, the input termination applies for IDT LVHSTL drivers. If you are using an LVHSTL driver from another vendor, use their termination recommendation.

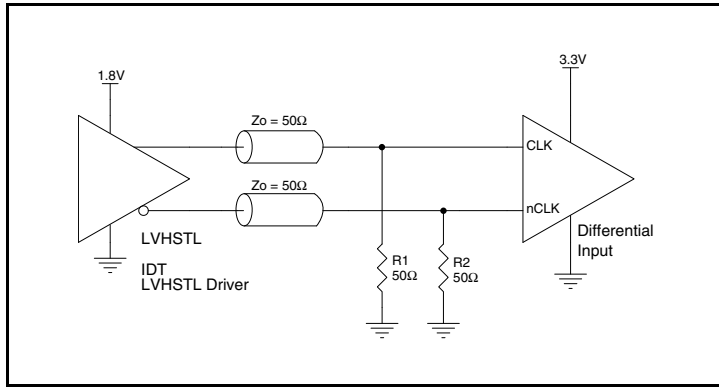

Figure 2A. CLK/ $\overline{\text{CLK}}$ Input Driven by an IDT LVHSTL Driver

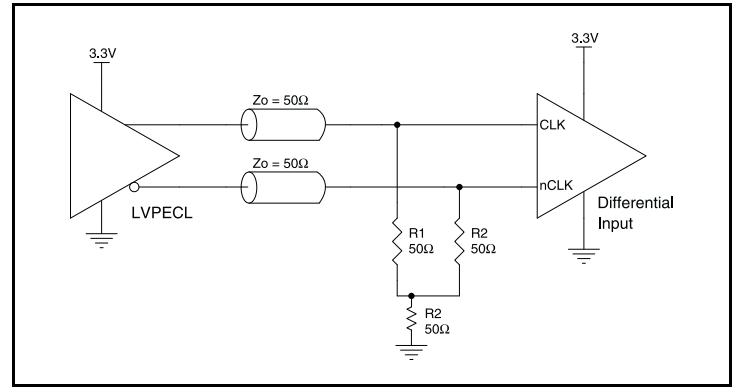

Figure 2B. CLK/ $\overline{\text{CLK}}$ Input Driven by a 3.3V LVPECL Driver

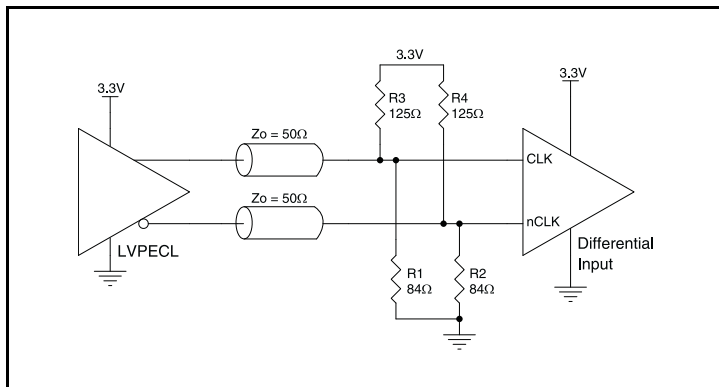

Figure 2C. CLK/ $\overline{\text{CLK}}$ Input Driven by a 3.3V LVPECL Driver

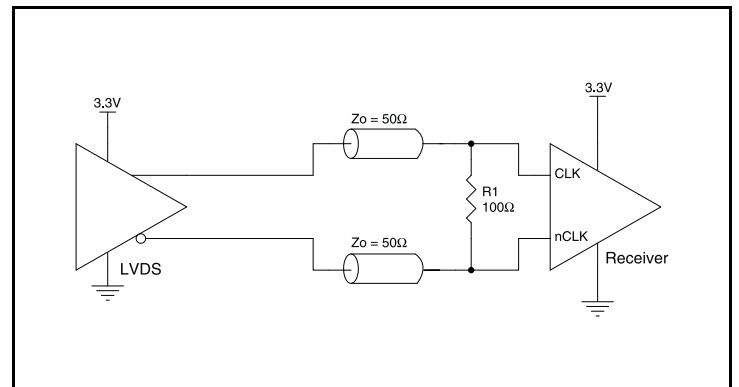

Figure 2D. CLK/ $\overline{\text{CLK}}$ Input Driven by a 3.3V LVDS Driver

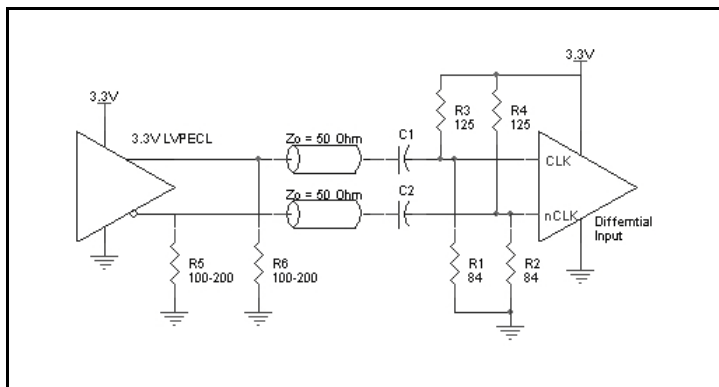

Figure 2E. CLK/ $\overline{\text{CLK}}$ Input Driven by a 3.3V LVPECL Driver with AC Couple

Reliability Information

Table 6. θ_{JA} vs. Air Flow Table for a 48 Lead LQFP

θ_{JA} vs. Air Flow			
Linear Feet per Minute	0	200	500
Single-Layer PCB, JEDEC Standard Test Boards	67.8°C/W	55.9°C/W	50.1°C/W
Multi-Layer PCB, JEDEC Standard Test Boards	47.9°C/W	42.1°C/W	39.4°C/W

NOTE: Most modern PCB design use multi-layered boards. The data in the second row pertains to most designs.

Transistor Count

The transistor count for 870161 is: 2034

Package Outline and Package Dimension

Package Outline - Y Suffix for 48 Lead LQFP

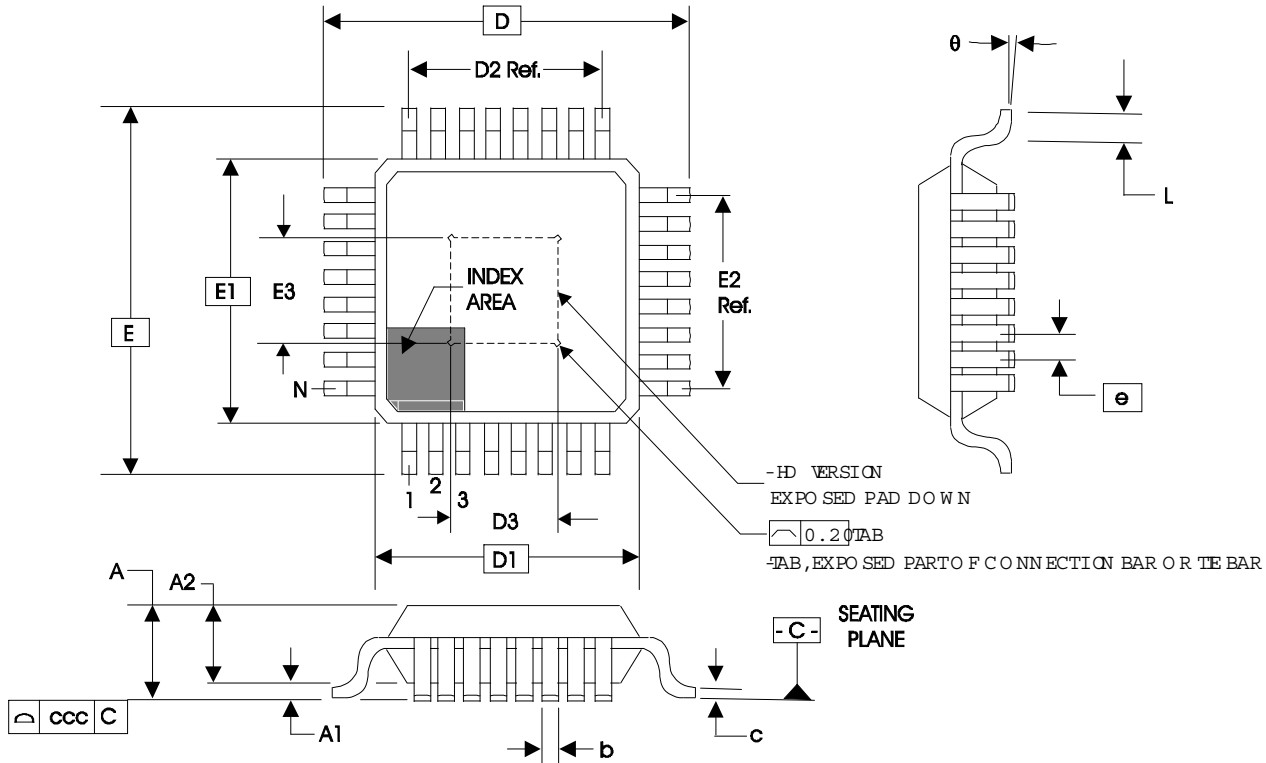

Table 7. Package Dimensions for 48 Lead LQFP

JEDEC Variation: ABC - HD			
All Dimensions in Millimeters			
Symbol	Minimum	Nominal	Maximum
N	48		
A			1.20
A1	0.05	0.10	0.15
A2	0.95	1.00	1.05
b	0.17	0.22	0.27
c	0.09		0.20
D & E	9.00 Basic		
D1 & E1	7.00 Basic		
D2 & E2	5.50 Ref.		
D3 & E3	2.0		7.0
e	0.5 Basic		
L	0.45	0.60	0.75
theta	0°		7°
ccc			0.08

Reference Document: JEDEC Publication 95, MS-026

Ordering Information

Table 8. Ordering Information

Part/Order Number	Marking	Package	Shipping Packaging	Temperature
ICS87016AYILF	ICS87016AYIL	"Lead-Free" 48 Lead LQFP	Tray	-40°C to 85°C
ICS87016AYILFT	ICS87016AYIL	"Lead-Free" 48 Lead LQFP	Tape & Reel	-40°C to 85°C

Revision History Sheet

Rev	Table	Page	Description of Change	Date
B		1	Features Section - added 2.5V/2.5V and 2.5V/1.8V to supply mode bullet. Added lead-free bullet	3/30/07
	T2	3	Pin Characteristics Table - added 2.5V/2.5V and 2.5V/1.8V to C_{PD} .	
	T4B	4	Added 2.5V Power Supply DC Characteristics Table.	
	T4C	5	LVC MOS DC Characteristics Table - added 2.5V to V_{IH}/V_{IL} .	
	T4D	5	Differential DC Characteristics Table - added 2.5V to I_{IH}/I_{IL} .	
	T5B	6	Added 2.5V Power Supply DC Characteristics Table.	
	T5E	8	Added 2.5V/1.8V Power Supply DC Characteristics Table.	
		9	Parameter Measurement Information - added <i>2.5V Core/2.5V Output Load Test Circuit</i> and <i>2.5V Core/1.8V Output Load Test Circuit diagrams</i> .	
		11	Added <i>Recommendations for Unused Input and Output Pins</i> .	
		15	Ordering Information Table - added lead-free Order/Part Number.	
C	T5B	6	2.5V AC Characteristics Table - changed <i>Output Duty Cycle</i> test condition and limits. Added Output Pulse Width.	5/25/07
C	T8	15	Remove leaded parts from Ordering Information table	11/15/12
C	4C	5	Corrected typo, VOH: $V_{DD} - 0.45$ to $V_{DDOX} - 0.45$	3/28/13
C	T8	15	Ordering Information - updated part marking. Updated data sheet format.	3/23/15



Corporate Headquarters
6024 Silver Creek Valley Road
San Jose, CA 95138 USA

Sales
1-800-345-7015 or 408-284-8200
Fax: 408-284-2775
www.IDT.com

Tech Support
email: clocks@idt.com

DISCLAIMER Integrated Device Technology, Inc. (IDT) and its subsidiaries reserve the right to modify the products and/or specifications described herein at any time and at IDT's sole discretion. All information in this document, including descriptions of product features and performance, is subject to change without notice. Performance specifications and the operating parameters of the described products are determined in the independent state and are not guaranteed to perform the same way when installed in customer products. The information contained herein is provided without representation or warranty of any kind, whether express or implied, including, but not limited to, the suitability of IDT's products for any particular purpose, an implied warranty of merchantability, or non-infringement of the intellectual property rights of others. This document is presented only as a guide and does not convey any license under intellectual property rights of IDT or any third parties.

IDT's products are not intended for use in applications involving extreme environmental conditions or in life support systems or similar devices where the failure or malfunction of an IDT product can be reasonably expected to significantly affect the health or safety of users. Anyone using an IDT product in such a manner does so at their own risk, absent an express, written agreement by IDT.

While the information presented herein has been checked for both accuracy and reliability, Integrated Device Technology (IDT) assumes no responsibility for either its use or for the infringement of any patents or other rights of third parties, which would result from its use. No other circuits, patents, or licenses are implied. This product is intended for use in normal commercial applications. Any other applications, such as those requiring extended temperature ranges, high reliability or other extraordinary environmental requirements are not recommended without additional processing by IDT. IDT reserves the right to change any circuitry or specifications without notice. IDT does not authorize or warrant any IDT product for use in life support devices or critical medical instruments.

Integrated Device Technology, IDT and the IDT logo are registered trademarks of IDT. Product specification subject to change without notice. Other trademarks and service marks used herein, including protected names, logos and designs, are the property of IDT or their respective third party owners.

Copyright ©2015 Integrated Device Technology, Inc.. All rights reserved.

Компания «Океан Электроники» предлагает заключение долгосрочных отношений при поставках импортных электронных компонентов на взаимовыгодных условиях!

Наши преимущества:

- Поставка оригинальных импортных электронных компонентов напрямую с производств Америки, Европы и Азии, а так же с крупнейших складов мира;
- Широкая линейка поставок активных и пассивных импортных электронных компонентов (более 30 млн. наименований);
- Поставка сложных, дефицитных, либо снятых с производства позиций;
- Оперативные сроки поставки под заказ (от 5 рабочих дней);
- Экспресс доставка в любую точку России;
- Помощь Конструкторского Отдела и консультации квалифицированных инженеров;
- Техническая поддержка проекта, помощь в подборе аналогов, поставка прототипов;
- Поставка электронных компонентов под контролем ВП;
- Система менеджмента качества сертифицирована по Международному стандарту ISO 9001;
- При необходимости вся продукция военного и аэрокосмического назначения проходит испытания и сертификацию в лаборатории (по согласованию с заказчиком);
- Поставка специализированных компонентов военного и аэрокосмического уровня качества (Xilinx, Altera, Analog Devices, Intersil, Interpoint, Microsemi, Actel, Aeroflex, Peregrine, VPT, Syfer, Eurofarad, Texas Instruments, MS Kennedy, Miteq, Cobham, E2V, MA-COM, Hittite, Mini-Circuits, General Dynamics и др.);

Компания «Океан Электроники» является официальным дистрибьютором и эксклюзивным представителем в России одного из крупнейших производителей разъемов военного и аэрокосмического назначения «JONHON», а так же официальным дистрибьютором и эксклюзивным представителем в России производителя высокотехнологичных и надежных решений для передачи СВЧ сигналов «FORSTAR».



JONHON

«JONHON» (основан в 1970 г.)

Разъемы специального, военного и аэрокосмического назначения:

(Применяются в военной, авиационной, аэрокосмической, морской, железнодорожной, горно- и нефтедобывающей отраслях промышленности)

«FORSTAR» (основан в 1998 г.)

ВЧ соединители, коаксиальные кабели, кабельные сборки и микроволновые компоненты:

(Применяются в телекоммуникациях гражданского и специального назначения, в средствах связи, РЛС, а так же военной, авиационной и аэрокосмической отраслях промышленности).



Телефон: 8 (812) 309-75-97 (многоканальный)

Факс: 8 (812) 320-03-32

Электронная почта: ocean@oceanchips.ru

Web: <http://oceanchips.ru/>

Адрес: 198099, г. Санкт-Петербург, ул. Калинина, д. 2, корп. 4, лит. А