

# MAX8814

## 28V Linear Li+ Battery Charger with Smart Autoboot Assistant

### General Description

The MAX8814 intelligent, stand-alone constant-current, constant-voltage (CCCV), thermally regulated linear charger is designed for charging a single-cell lithium-ion (Li+) battery.

The MAX8814 controls the charging sequence from the prequalification state through constant-current fast-charge and the final constant voltage charge. The IC achieves high flexibility by providing an adjustable fast-charge current through an external resistor. It also features a booting assistant circuit that distinguishes input sources and battery connection, and provides an output signal (ABO) for system booting.

The device operates over the extended temperature range (-40°C to +85°C), and is available in an 8-pin thermally enhanced 2mm x 2mm TDFN package (0.8mm max height).

### Applications

- Smartphones
- Portable Music Players
- Digital Still Cameras
- USB Appliances
- Charging Cradles and Docks
- Bluetooth® Equipment

### Benefits and Features

- Reduces External Components and Total Cost
  - Integrated Current-Sensing Circuit, MOSFET Pass Element, and Thermally Regulation Circuitry
  - No Reverse Blocking Diode Required
- Guarantees Safe and Accurate Battery Charging
  - Proprietary Die Temperature Regulation Control (+115°C) Allows Maximum Charging Current Without Damaging the IC
  - 4.25V to 28V Input Voltage Range with Over-Voltage Protection Above +7V to Protect Against Unqualified or Faulty AC Adapters
  - Soft-Start Limits Inrush Current
- Integrated System Features for Compact Designs
  - Programmable Fast-Charge Current: 1A<sub>RMS</sub> Max
  - Charge-Current Monitor for Fuel Gauging (ISET)
  - Input Power-Source Detection Output (POK) and Charge-Enable Input (EN)
  - Output for Autobooting (ABO)
- Reduce Power Dissipation
  - Low Dropout Voltage (300mV at 500mA)

### Ordering Information

PART	TEMP RANGE	PIN-PACKAGE	TOP MARK
MAX8814ETA+	-40°C to +85°C	8 TDFN (2mm x 2mm)	ABI

+Denotes a lead-free and RoHS-compliant package.

### Typical Operating Circuit

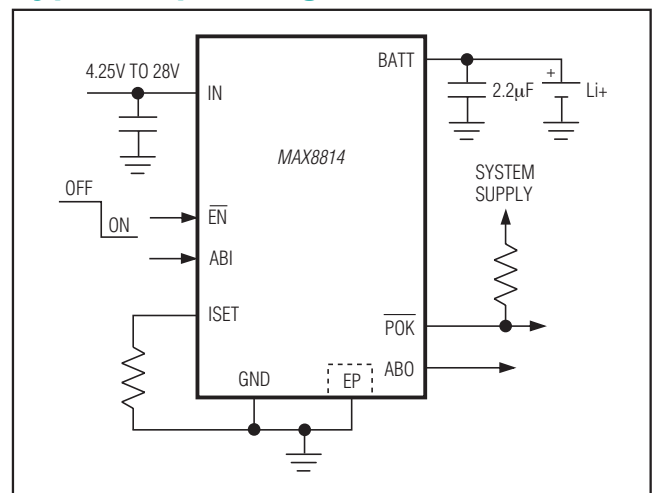

Bluetooth is a registered trademark of Bluetooth SIG.

Pin Configuration appears at end of data sheet.

## Absolute Maximum Ratings

IN to GND	-0.3V to +30V
ABI, BATT, $\overline{EN}$ , POK to GND	-0.3V to +6V
ABO to GND	-0.3V to ( $V_{BATT} + 0.3V$ )
ISET to GND	-0.3V to +4V
IN to BATT Continuous Current	1A <sub>RMS</sub>
Continuous Power Dissipation ( $T_A = +70^\circ\text{C}$ )	
8-Pin TDFN (derate 11.9mW/°C above +70°C)	
(multilayer PCB)	953.5mW

BATT Short-Circuit Duration	Continuous
Operating Temperature Range	-40°C to +85°C
Junction Temperature	+150°C
Storage Temperature Range	-65°C to +150°C
Lead Temperature (soldering, 10s)	+300°C

Stresses beyond those listed under "Absolute Maximum Ratings" may cause permanent damage to the device. These are stress ratings only, and functional operation of the device at these or any other conditions beyond those indicated in the operational sections of the specifications is not implied. Exposure to absolute maximum rating conditions for extended periods may affect device reliability.

## Electrical Characteristics

( $V_{IN} = 5V$ ,  $V_{BATT} = 4V$ ,  $R_{POK} = 1M\Omega$  to BATT,  $\overline{EN} = 0V$ ,  $R_{ISET} = 2.8k\Omega$  to GND,  $C_{BATT} = 2.2\mu F$ ,  $T_A = -40^\circ\text{C}$  to  $+85^\circ\text{C}$ , unless otherwise noted. Typical values are at  $T_A = +25^\circ\text{C}$ .) (Note 1)

PARAMETER	CONDITIONS		MIN	TYP	MAX	UNITS
Input Voltage Range			0		28	V
Input Operating Voltage Range			4.25		6.80	V
Power-OK Threshold	$V_{IN} - V_{BATT}$ , 10mV hysteresis (typ)	$V_{IN}$ rising		40		mV
		$V_{IN}$ falling		30		
Overvoltage-Lockout Trip Threshold	$V_{IN}$ rising, 100mV hysteresis (typ)		6.8	7	7.5	V
IN Input Current	Constant-current charging mode ( $I_{BATT} = 0A$ )			0.8	1.35	mA
	IC disabled ( $V_{\overline{EN}} = 5V$ )			0.23	0.50	
	$V_{IN} = 4V$ , $V_{BATT} = 4.2V$	$T_A = +25^\circ\text{C}$		0.021	0.065	
		$T_A = +85^\circ\text{C}$		0.021		
BATT Input Current	$V_{IN} = 0$ to 4V, $V_{BATT} = 4.2V$			1	10	$\mu A$
	IC disabled			3		
Battery Regulation Voltage	$I_{BATT} = 0A$	$T_A = 0^\circ\text{C}$ to $+85^\circ\text{C}$	4.179	4.200	4.221	V
		$T_A = -40^\circ\text{C}$ to $+85^\circ\text{C}$	4.158	4.200	4.242	
Minimum BATT Bypass Capacitance				2.2		$\mu F$
Fast-Charge Current	$V_{BATT} = 3.5V$	$T_A = 0^\circ\text{C}$ to $+85^\circ\text{C}$	524	570	616	mA
		$T_A = -40^\circ\text{C}$ to $+85^\circ\text{C}$	485	570	656	
	$V_{BATT} = 3.5V$ , $R_{ISET} = 14k\Omega$	$T_A = 0^\circ\text{C}$ to $+85^\circ\text{C}$	89	107	125	
		$T_A = -40^\circ\text{C}$ to $+85^\circ\text{C}$	80	107	134	
Prequalification Charge Current	Percentage of the fast-charge current, $V_{BATT} = 2.2V$ , $T_A = 0^\circ\text{C}$ to $+85^\circ\text{C}$		4	10	15	%
Die Temperature Regulation Threshold				+115		$^\circ\text{C}$
$V_{BATT}$ Prequalification Threshold Voltage	$V_{BATT}$ rising, 100mV hysteresis (typ)		2.3	2.5	2.7	V
Current-Sense Amplifier Gain ( $I_{BATT}$ to $I_{SET}$ )	$I_{BATT} = 570mA$			877.2		$\mu A/A$

### Electrical Characteristics (continued)

( $V_{IN} = 5V$ ,  $V_{BATT} = 4V$ ,  $R_{\overline{POK}} = 1M\Omega$  to BATT,  $\overline{EN} = 0V$ ,  $R_{ISET} = 2.8k\Omega$  to GND,  $C_{BATT} = 2.2\mu F$ ,  $T_A = -40^\circ C$  to  $+85^\circ C$ , unless other-

PARAMETER	CONDITIONS	MIN	TYP	MAX	UNITS
Regulator Dropout Voltage ( $V_{IN} - V_{BATT}$ )	$V_{BATT} = 4.1V$ , $I_{BATT} = 425mA$		240	500	mV
$\overline{EN}$ Logic-Input Low Voltage	$4.25V < V_{IN} < 6.5V$			0.4	V
$\overline{EN}$ Logic-Input High Voltage	$4.25V < V_{IN} < 6.5V$	1.3			V
$\overline{EN}$ and ABI Internal Pulldown Resistance		100	200	400	$k\Omega$
ABI Logic-Input Low Voltage	$V_{IN} = 0V$			0.4	V
ABI Logic-Input High Voltage	$V_{IN} = 0V$	1.3			V
ABO Output Low Voltage	$I_{ABO} (SINK) = 1mA$			0.4	V
ABO Output High Voltage	$I_{ABO} (SOURCE) = 1mA$	$V_{BATT} - 0.4V$			V
$\overline{POK}$ Output Low Voltage	$I_{\overline{POK}} = 5mA$			0.4	V
$\overline{POK}$ Output High Leakage Current	$V_{\overline{POK}} = 5.5V$	$T_A = +25^\circ C$	0.001	1	$\mu A$
		$T_A = +85^\circ C$	0.002		

**Note 1:** Specifications are 100% production tested at  $T_A = +25^\circ C$ . Limits over the operating temperature range are guaranteed by design and characterization.

### Typical Operating Characteristics

( $V_{IN} = 5V$ ,  $V_{BATT} = 4V$ ,  $R_{\overline{POK}} = 1M\Omega$  to BATT,  $\overline{EN} = 0V$ ,  $R_{ISET} = 2.8k\Omega$  to GND,  $C_{BATT} = 2.2\mu F$ ,  $T_A = -40^\circ C$  to  $+85^\circ C$ , unless other-

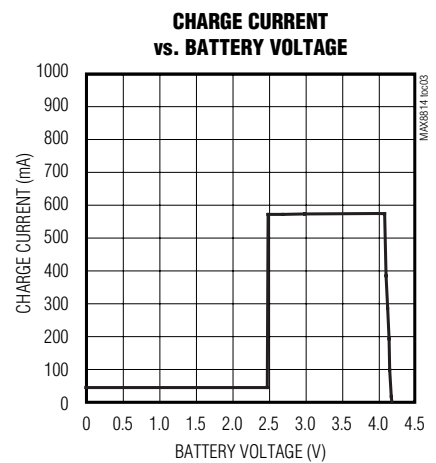
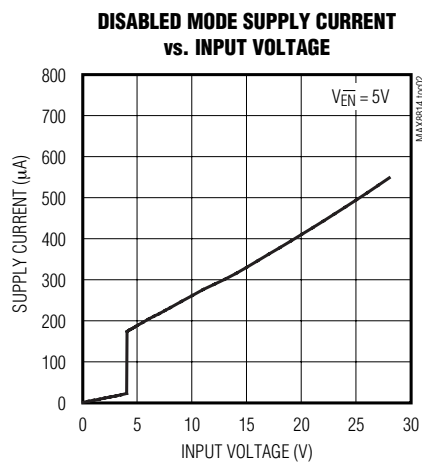
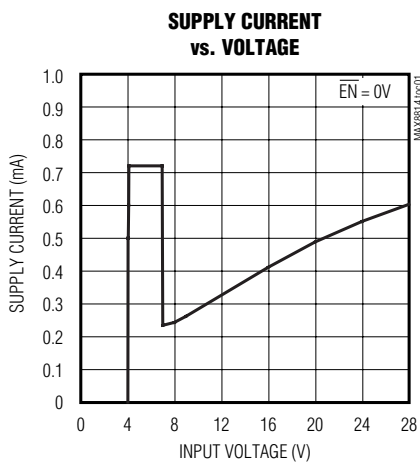

Package Information (continued)

( $V_{IN} = 5V$ ,  $V_{BATT} = 4V$ ,  $R_{POK} = 1M\Omega$  to BATT,  $\overline{EN} = 0V$ ,  $R_{ISET} = 2.8k\Omega$  to GND,  $C_{BATT} = 2.2\mu F$ ,  $T_A = -40^\circ C$  to  $+85^\circ C$ , unless otherwise noted. Typical values are at  $T_A = +25^\circ C$ .)

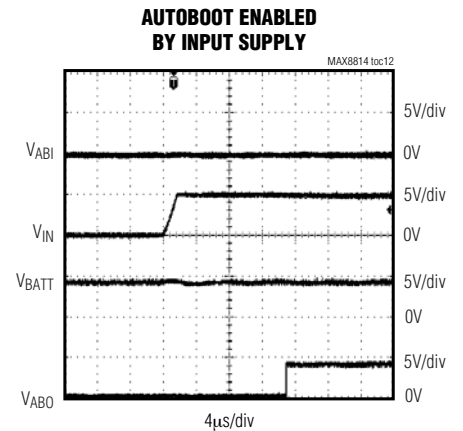
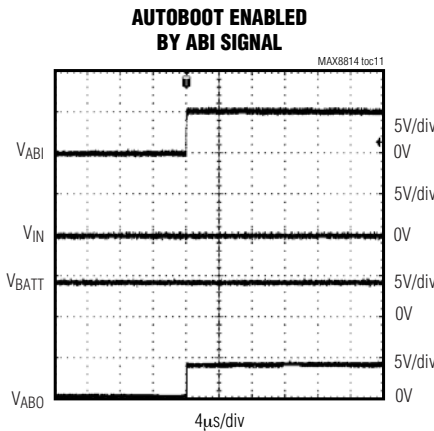
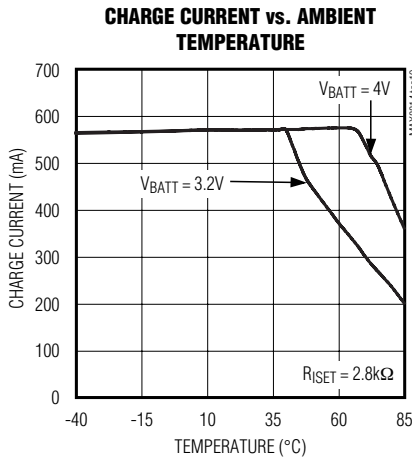
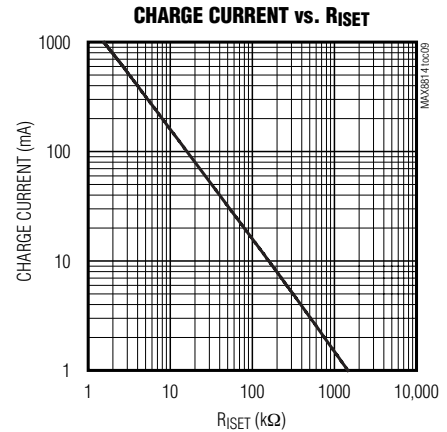
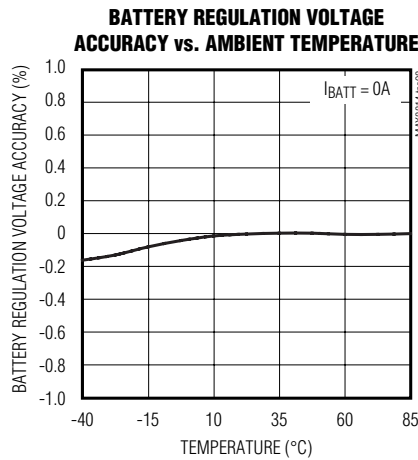
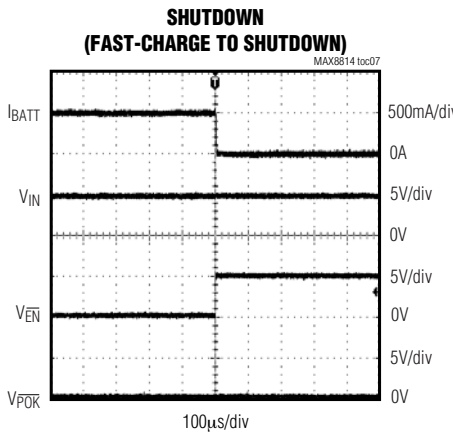
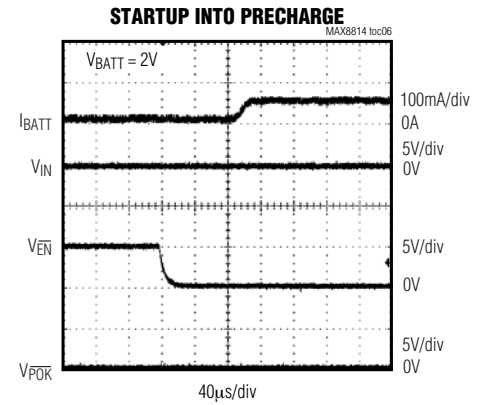
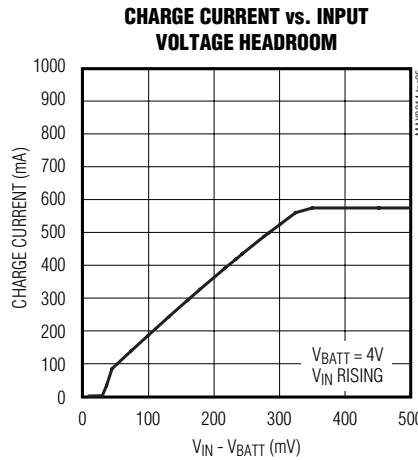
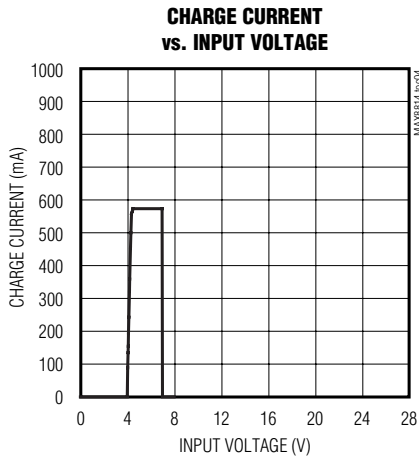

## Pin Description

PIN	NAME	FUNCTION
1	IN	Input Supply Voltage. Bypass IN to GND with a 1 $\mu$ F or larger ceramic capacitor to minimize line noise and maximize input transient rejection.
2	GND	Ground. Connect GND and the exposed paddle to a large copper ground plane for maximum power dissipation. Connect GND to the exposed paddle directly under the IC.
3	ISET	Charge-Current Program and Fast-Charge Current Monitor. Output current from ISET is 877.2 $\mu$ A per ampere of battery charging current. Set the charging current by connecting a resistor (R2 in Figure 3) from ISET to GND. $I_{FAST-CHARGE} = 1596V / R_{ISET}$ . To configure the MAX8814 as a USB charger, see Figure 4.
4	ABI	Autobooting External Input. See the <i>Autobooting Assistant</i> section and Table 1 for autobooting conditions. ABI is pulled to GND through an internal 200k $\Omega$ resistor.
5	ABO	Autobooting Logic Output. See the <i>Autobooting Assistant</i> section and Table 1 for autobooting conditions.
6	$\overline{EN}$	Logic-Level Enable Input. Drive $\overline{EN}$ high to disable charger. Drive $\overline{EN}$ low or leave unconnected for normal operation. $\overline{EN}$ has an internal 200k $\Omega$ pulldown resistor.
7	$\overline{POK}$	Input-Voltage Status Indicator. Connect a 1M $\Omega$ pullup resistor from $\overline{POK}$ to an external system supply. $\overline{POK}$ is an open-drain output that asserts low when $V_{IN} > 4.25V$ and $(V_{IN} - V_{BATT}) \geq 40mV$ . If $V_{BATT} \geq (V_{IN} - 40mV)$ , the IC is shut down and $\overline{POK}$ becomes high impedance.
8	BATT	Battery Connection. Bypass BATT to GND with a minimum of 2.2 $\mu$ F of capacitor.
—	EP	Exposed Paddle. Connect the exposed paddle to a large ground plane for maximum power dissipation. Connect GND to the exposed paddle directly under the IC.



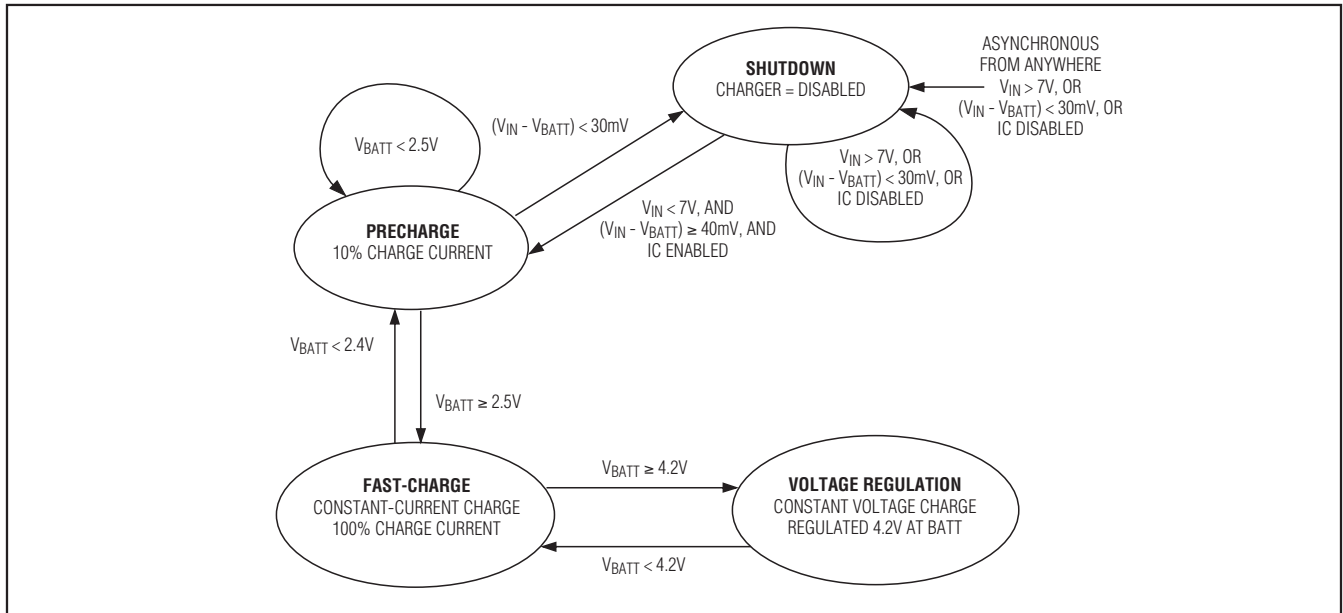

Figure 2. Charge-State Diagram

### Charger Enable Input

The MAX8814 contains an active-low logic input ( $\overline{\text{EN}}$ ) used to enable the charger. Drive  $\overline{\text{EN}}$  low, leave unconnected, or connect to GND to enable the charger-control circuitry. Drive  $\overline{\text{EN}}$  high to disable the charger-control circuitry.  $\overline{\text{EN}}$  has an internal 200k $\Omega$  pull-down resistor.

### $\overline{\text{POK}}$ Output

The open-drain  $\overline{\text{POK}}$  output asserts low when  $V_{\text{IN}} \geq 4.25\text{V}$  and  $(V_{\text{IN}} - V_{\text{BATT}}) \geq 40\text{mV}$  (typ,  $V_{\text{IN}}$  rising).  $\overline{\text{POK}}$  requires an external pullup resistor (1M $\Omega$  typ) to an external power supply.  $\overline{\text{POK}}$  is high impedance when  $V_{\text{BATT}} \geq (V_{\text{IN}} - 40\text{mV})$ .

### Autobooting Assistant

The MAX8814 contains an autobooting assistant circuit that generates an enable signal for system booting (ABO). The booting assistant functions as an internal “OR” gate (Figure 1). The first input is dependent on the input voltage ( $V_{\text{IN}}$ ), and the second input is an external signal applied to ABI. The first input ( $\overline{\text{POK}}$ ) is driven high once  $V_{\text{IN}} \geq 4.25\text{V}$  and  $(V_{\text{IN}} - V_{\text{BATT}}) \geq 40\text{mV}$  (typ,  $V_{\text{IN}}$  rising).

The second input signal (ABI) is driven by an external source. ABI enables an autoboot signal (ABO high) when a battery is connected at BATT and is independent

Table 1. ABO and POK States

ABI	BATT	$\overline{\text{POK}}$	CHARGER STATE	ABO
Low	Present	Hi-Z	Shutdown	Low
High	Present	Hi-Z	Shutdown	High
X	Not present	Low	Fast-charge/voltage regulation	High
X	Present	Low	Fast-charge/voltage regulation	High

X = Don't care.

of  $\overline{\text{POK}}$ . If  $\overline{\text{POK}}$  is pulled low, the booting assistant always drives ABO high, regardless of ABI (see Table 1). ABI is pulled to GND through an internal 200k $\Omega$  resistor. If ABI is driven externally, a RC filter (R1 and C2 of Figure 3) is required for ESD protection and noise filtering. If ABI is supplied by a system's internal GPIO, or logic, the RC filter is not required.

### Soft-Start

The soft-start algorithm activates when entering fast-charge mode. In the MAX8814, when the prequalification state is complete ( $V_{\text{BATT}} \geq 2.5\text{V}$ ), the charging current ramps up in 250 $\mu\text{s}$  to the full charging current. This reduces the inrush current on the input supply.

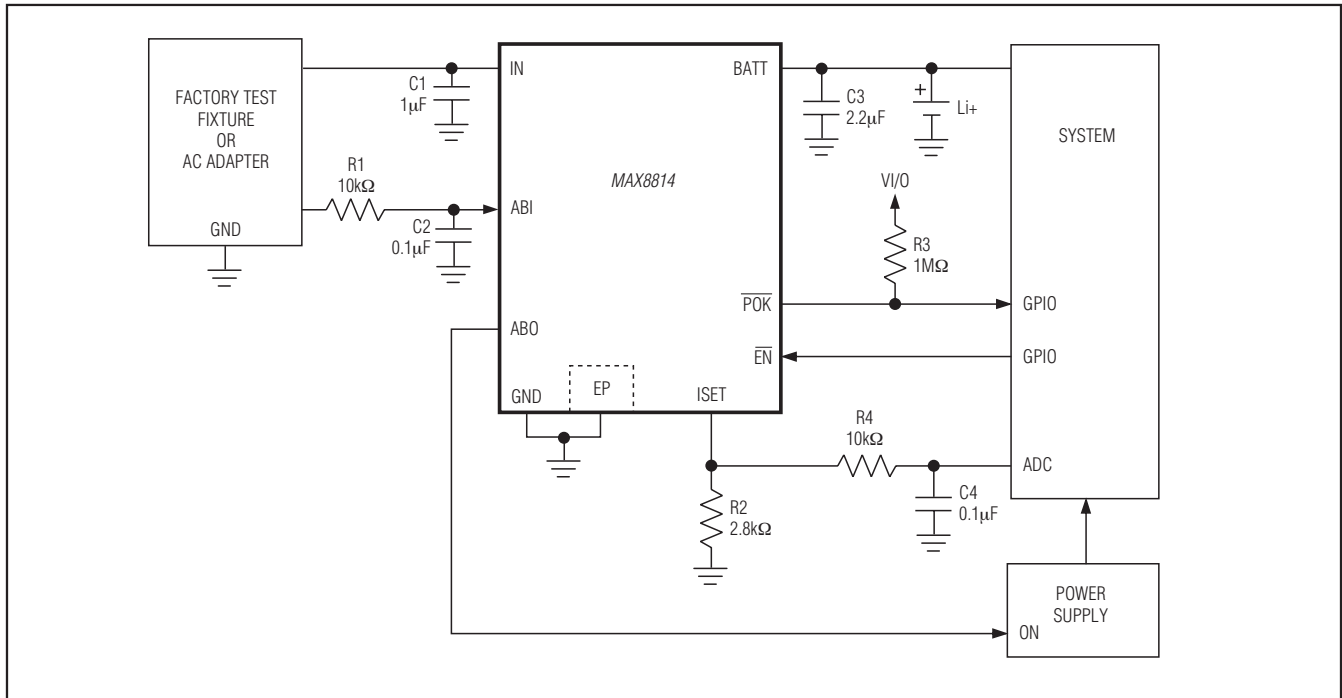

Figure 3. Microprocessor-Interfaced Li+ Battery Charger

## Applications Information

### Charge-Current Selection

The maximum charging current is programmed by an external resistor connected from ISET to GND ( $R_{ISET}$ ). Calculate  $R_{ISET}$  as follows:

$$R_{ISET} = \frac{1596V}{I_{FAST-CHARGE}}$$

where  $I_{FAST-CHARGE}$  is in amperes and  $R_{ISET}$  is in ohms. ISET can be used to monitor the fast-charge current level. The output current from ISET is 877.2µA per ampere of charging current. The output voltage at ISET is proportional to the charging current:

$$V_{ISET} = \frac{I_{CHARGE} \times R_{ISET}}{1140}$$

The voltage at ISET is nominally 1.4V at the selected fast-charge current and falls with charging current as the cell becomes fully charged or as the thermal-regulation circuitry activates.

### Capacitor Selection

Connect a ceramic capacitor from BATT to GND for proper stability. Use a 2.2µF X5R ceramic capacitor for most applications. Connect a 1µF ceramic capacitor from IN to GND. Use a larger input bypass capacitor for high charging currents to reduce supply noise.

### Thermal Considerations

The MAX8814 is available in a thermally enhanced TDFN package with an exposed paddle. Connect the exposed paddle to a large copper ground plane to provide a thermal contact between the device and the circuit board for increased power dissipation. The exposed paddle transfers heat away from the device, allowing the IC to charge the battery with maximum current, while minimizing the increase in die temperature.

### DC Input Sources

The MAX8814 operates from a well-regulated DC source. The full charging input voltage range is 4.25V to 7V. The device can withstand up to 28V on the input without damage to the IC. If  $V_{IN}$  is greater than 7V, the internal overvoltage-protection circuitry disables charging until the input falls below 7V. An appropriate power supply must provide at least 4.25V at the desired peak charging current.



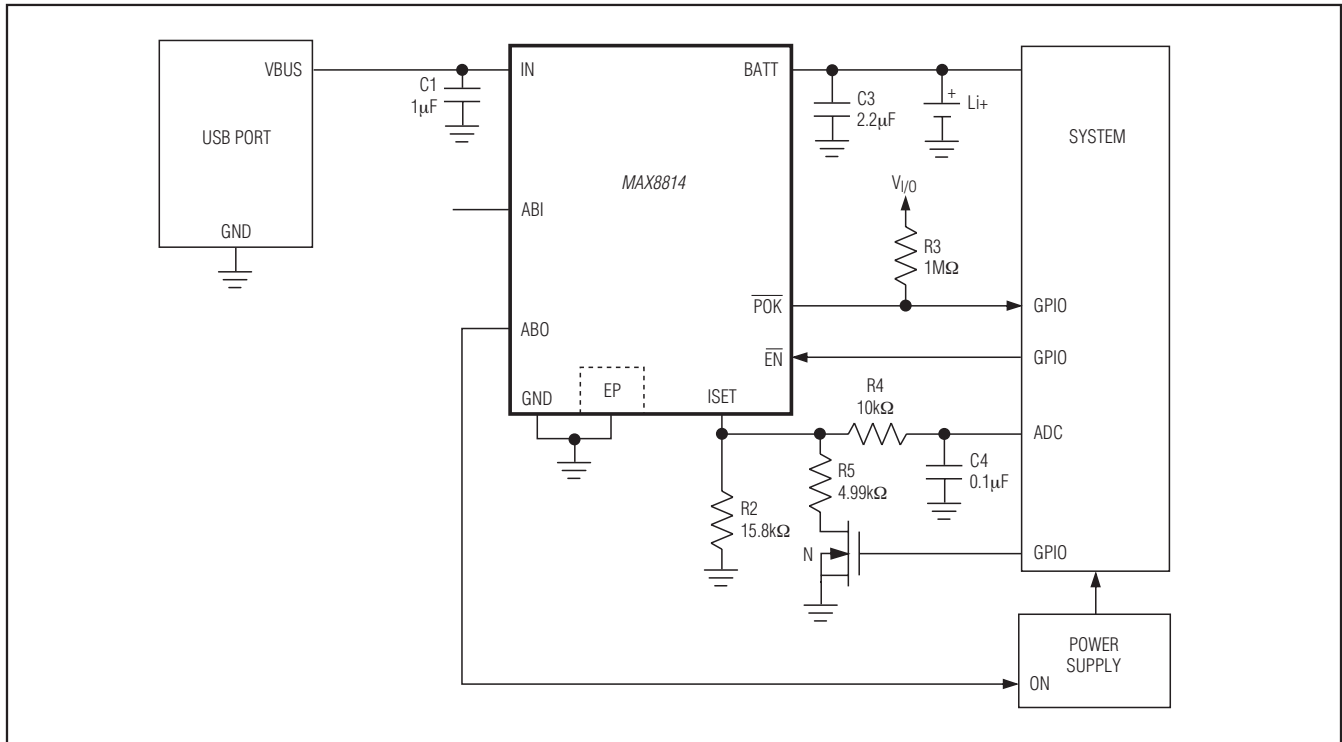

Figure 4. USB Battery Charger

## Application Circuits

### Microprocessor-Interfaced Charger

Figure 3 shows the MAX8814 as a microprocessor-cooperated Li+ battery charger. The MAX8814 begins charging the battery when  $\overline{EN}$  is low. The microprocessor can drive  $\overline{EN}$  high to disable the charger. The MAX8814 generates a  $\overline{POK}$  signal to indicate the presence of an input supply. By monitoring  $V_{ISET}$ , the system can measure the charging current and decide when to terminate the charge.

### USB-Powered Li-Ion Charger

The universal serial bus (USB) provides a high-speed serial communication port as well as power for the remote device. The MAX8814 can be configured to charge a battery at the highest current possible from the host port. Figure 4 shows the MAX8814 as a USB battery charger. To make the circuit compatible with either 100mA or 500mA USB ports, the circuit initializes at 100mA charging current. The microprocessor then enumerates the host to determine its current capability. If the host port is capable, the charging current is increased to 425mA to avoid exceeding the 500mA USB specification.

## Layout and Bypassing

Place the input and output capacitors as close as possible to the IC. Provide a large copper ground plane to allow the exposed paddle to sink heat away from the IC. Connect the battery to BATT as close as possible to the IC to provide accurate battery voltage sensing. Make all high-current traces short and wide to minimize voltage drops. A sample layout is available in the MAX8814 Evaluation Kit to speed designs.

## Chip Information

PROCESS: BiCMOS

### Pin Configuration

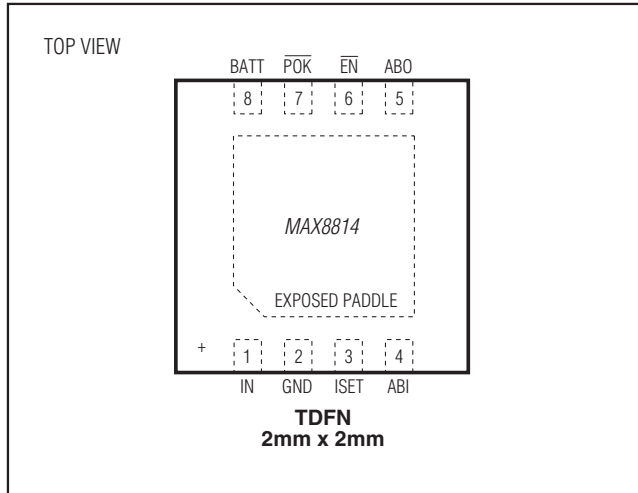

### Package Information

For the latest package outline information and land patterns (footprints), go to [www.maximintegrated.com/packages](http://www.maximintegrated.com/packages). Note that a "+", "#", or "-" in the package code indicates RoHS status only. Package drawings may show a different suffix character, but the drawing pertains to the package regardless of RoHS status.

PACKAGE TYPE	PACKAGE CODE	DOCUMENT NO.
8 TDFN	T822+2	<a href="#">21-0168</a>

## Revision History

REVISION NUMBER	REVISION DATE	DESCRIPTION	PAGES CHANGED
0	10/07	Initial release	—
1	2/08	Changed OVP (min) to 6.8V from 6.5V with 6 sigma without silicon change	2
2	3/08	Changed Input Operating Voltage maximum range from 6.8V to 6.5V.	1
3	5/15	Revised <i>General Description</i> and <i>Benefits and Features</i> section	1

For pricing, delivery, and ordering information, please contact Maxim Direct at 1-888-629-4642, or visit Maxim Integrated's website at [www.maximintegrated.com](http://www.maximintegrated.com).

Maxim Integrated cannot assume responsibility for use of any circuitry other than circuitry entirely embodied in a Maxim Integrated product. No circuit patent licenses are implied. Maxim Integrated reserves the right to change the circuitry and specifications without notice at any time. The parametric values (min and max limits) shown in the Electrical Characteristics table are guaranteed. Other parametric values quoted in this data sheet are provided for guidance.

Компания «Океан Электроники» предлагает заключение долгосрочных отношений при поставках импортных электронных компонентов на взаимовыгодных условиях!

Наши преимущества:

- Поставка оригинальных импортных электронных компонентов напрямую с производств Америки, Европы и Азии, а так же с крупнейших складов мира;
- Широкая линейка поставок активных и пассивных импортных электронных компонентов (более 30 млн. наименований);
- Поставка сложных, дефицитных, либо снятых с производства позиций;
- Оперативные сроки поставки под заказ (от 5 рабочих дней);
- Экспресс доставка в любую точку России;
- Помощь Конструкторского Отдела и консультации квалифицированных инженеров;
- Техническая поддержка проекта, помощь в подборе аналогов, поставка прототипов;
- Поставка электронных компонентов под контролем ВП;
- Система менеджмента качества сертифицирована по Международному стандарту ISO 9001;
- При необходимости вся продукция военного и аэрокосмического назначения проходит испытания и сертификацию в лаборатории (по согласованию с заказчиком);
- Поставка специализированных компонентов военного и аэрокосмического уровня качества (Xilinx, Altera, Analog Devices, Intersil, Interpoint, Microsemi, Actel, Aeroflex, Peregrine, VPT, Syfer, Eurofarad, Texas Instruments, MS Kennedy, Miteq, Cobham, E2V, MA-COM, Hittite, Mini-Circuits, General Dynamics и др.);

Компания «Океан Электроники» является официальным дистрибьютором и эксклюзивным представителем в России одного из крупнейших производителей разъемов военного и аэрокосмического назначения «JONHON», а так же официальным дистрибьютором и эксклюзивным представителем в России производителя высокотехнологичных и надежных решений для передачи СВЧ сигналов «FORSTAR».



## JONHON

«JONHON» (основан в 1970 г.)

Разъемы специального, военного и аэрокосмического назначения:

(Применяются в военной, авиационной, аэрокосмической, морской, железнодорожной, горно- и нефтедобывающей отраслях промышленности)

«FORSTAR» (основан в 1998 г.)

ВЧ соединители, коаксиальные кабели, кабельные сборки и микроволновые компоненты:

(Применяются в телекоммуникациях гражданского и специального назначения, в средствах связи, РЛС, а так же военной, авиационной и аэрокосмической отраслях промышленности).



Телефон: 8 (812) 309-75-97 (многоканальный)

Факс: 8 (812) 320-03-32

Электронная почта: [ocean@oceanchips.ru](mailto:ocean@oceanchips.ru)

Web: <http://oceanchips.ru/>

Адрес: 198099, г. Санкт-Петербург, ул. Калинина, д. 2, корп. 4, лит. А