

QUICK START GUIDE FOR DEMONSTRATION CIRCUIT 658 MULTI-OUTPUT DC/DC CONVERTER POWERED BY 2-CELL, USB OR WALL ADAPTER

LTC3456

DESCRIPTION

Demonstration Circuit 658 is a complete power management system using the LTC3456 for portable applications powered by a wall adapter, a USB port or a 2-cell alkaline battery, in that order of priority. DC658 provides three outputs: a 1.8V, 200mA core supply, a 3.3V, 150mA main supply, and a 3.3V, 50mA Hot Swap supply. All outputs are discharged to ground during shutdown.

The 1.8V output switcher is a high efficiency, 1MHz fixed frequency synchronous buck regulator. The 3.3V output switcher is a high efficiency, 1MHz fixed frequency synchronous buck regulator (when powered from a wall adapter or a USB port), or a synchronous boost regulator (when powered from a 2-cell alkaline battery).

When using a long wire connection to the input source (a wall adapter or a USB port), there can be large voltage transients during initial plug-in due to the stray wiring inductance. This voltage spike can be large enough to damage the LTC3456. C7, R16, C8, and R20 are used to damp the possible voltage transients. Please refer to Application Note 88 for details. Since the battery is usually assembled close to the circuit and its series resistance also provides damping for the resonant tank, C11 at the battery input is mainly intended for demo board evaluations when a bench power supply is used to simulate the battery voltage.

Design files for this circuit board are available. Call the LTC factory.

Table 1. Performance Summary ($T_A = 25^\circ\text{C}$ unless otherwise noted)

PARAMETER	CONDITION	VALUE
Battery Input Voltage Range		2V to 3.2V
USB Input Voltage Range		4.35V to 5.5V
Wall Adapter Input Voltage Range		4.5V to 5.5V
Core Output Voltage	$V_{BAT} = 2.4V, I_{OUT1} = 0\text{mA to } 200\text{mA}$	1.8V $\pm 4\%$
Typical Output Ripple (Core)	$V_{BAT} = 2.4V, I_{OUT1} = 200\text{mA}$ (20MHz BW)	5mV _{PP}
Main Output Voltage	$V_{BAT} = 2.4V, I_{OUT2} = 0\text{mA to } 150\text{mA}$	3.27V $\pm 4\%$
Typical Output Ripple (Main)	$V_{BAT} = 2.4V, I_{OUT2} = 150\text{mA}$ (20MHz BW)	25mV _{PP}
Hot Swap Output Voltage	$V_{BAT} = 2.4V, I_{OUT3} = 0\text{mA to } 50\text{mA}$	3.27V $\pm 4\%$
Typical Output Ripple (Main)	$V_{BAT} = 2.4V, I_{OUT3} = 50\text{mA}$ (20MHz BW)	8mV _{PP}
Typical Switching Frequency (All Switchers)		1MHz
Efficiency (Fixed Frequency Mode)	$V_{BAT} = 2.4V, I_{OUT1} = 200\text{mA}, I_{OUT2} = 150\text{mA}, I_{OUT3} = 50\text{mA}$	88% Typical
USB maximum current in 500mA mode	USB voltage is 5V, USB Active and 500mA mode	500mA (max)
USB maximum current in 100mA mode	USB voltage is 5V, USB Active and 100mA mode	100mA (max)

QUICK START PROCEDURE

Demonstration circuit 658 is easy to set up to evaluate the performance of the LTC3456. Refer to Figure 1 for proper measurement equipment setup and follow the procedure below:

NOTE: When measuring the input or output voltage ripple, care must be taken to avoid a long ground lead on the oscilloscope probe. Measure the input or output voltage ripple by touching the probe tip directly across the Vin or Vout and GND terminals. See Figure 2 for proper scope probe technique.

BATTERY POWERED OPERATION

1. Set both the wall adapter input voltage and USB input voltage to zero. The circuit is now powered from the battery input. If a bench power supply is used, set the voltage between 2V and 3.2V.
2. Push ON button to start the converter. Note that the Reset LED goes on for 262msec. This simulates the reset signal that the LTC3456 provides to the micro-processor during initial power up.
3. When powered by the battery, the Burst Mode can be selected to improve light load efficiency by use of the Mode jumper (JP1). Once selected, each switcher will automatically enter into Burst Mode operation when its load current falls below a predetermined value.
4. Check for the proper output voltages.

NOTE: If any output is not in regulation, temporarily disconnect the load at the output to make sure that the load current is not set too high. The MAIN (Vout2) and HOT SWAP (Vout3) outputs will be turned off when the CORE output (Vout1) goes out of regulation.

5. Once the proper output voltages are established, adjust the load currents within the operating range and observe the output voltage regulation, ripple voltage, efficiency and other parameters.
6. Pushing the OFF button turns off the converter.

USB POWERED OPERATION

7. Place the USB SUSPEND jumper in the USB active position. Place the USB CURRENT jumper in the 500mA position. Keep the wall adapter input voltage at zero. Set the USB input voltage above 4.35V. (The EXT PWR LED goes on when the USB pin voltage is greater than 4.1V)

NOTE: Make sure that the USB input voltage does not exceed 5.5V.

8. Repeat 4 and 5 to evaluate the circuit operation. When powered by the USB input, the converter always operates in forced PWM mode regardless of the status of the MODE pin.

AC WALL ADAPTER POWERED OPERATION

9. Ramp up the wall adapter voltage. When the wall adapter voltage exceeds 4.5V, the converter will switch over from USB input to be powered by the wall adapter.

NOTE: Make sure that the wall adapter input voltage does not exceed 5.5V.

10. Repeat 4 and 5 to evaluate the circuit operation. When powered by the wall adapter, the converter always operates in forced PWM mode regardless of the status of the MODE pin.

QUICK START GUIDE FOR DEMONSTRATION CIRCUIT 658

MULTI-OUTPUT DC/DC CONVERTER POWERED BY 2-CELL, USB OR WALL ADAPTER

GRAPHICS

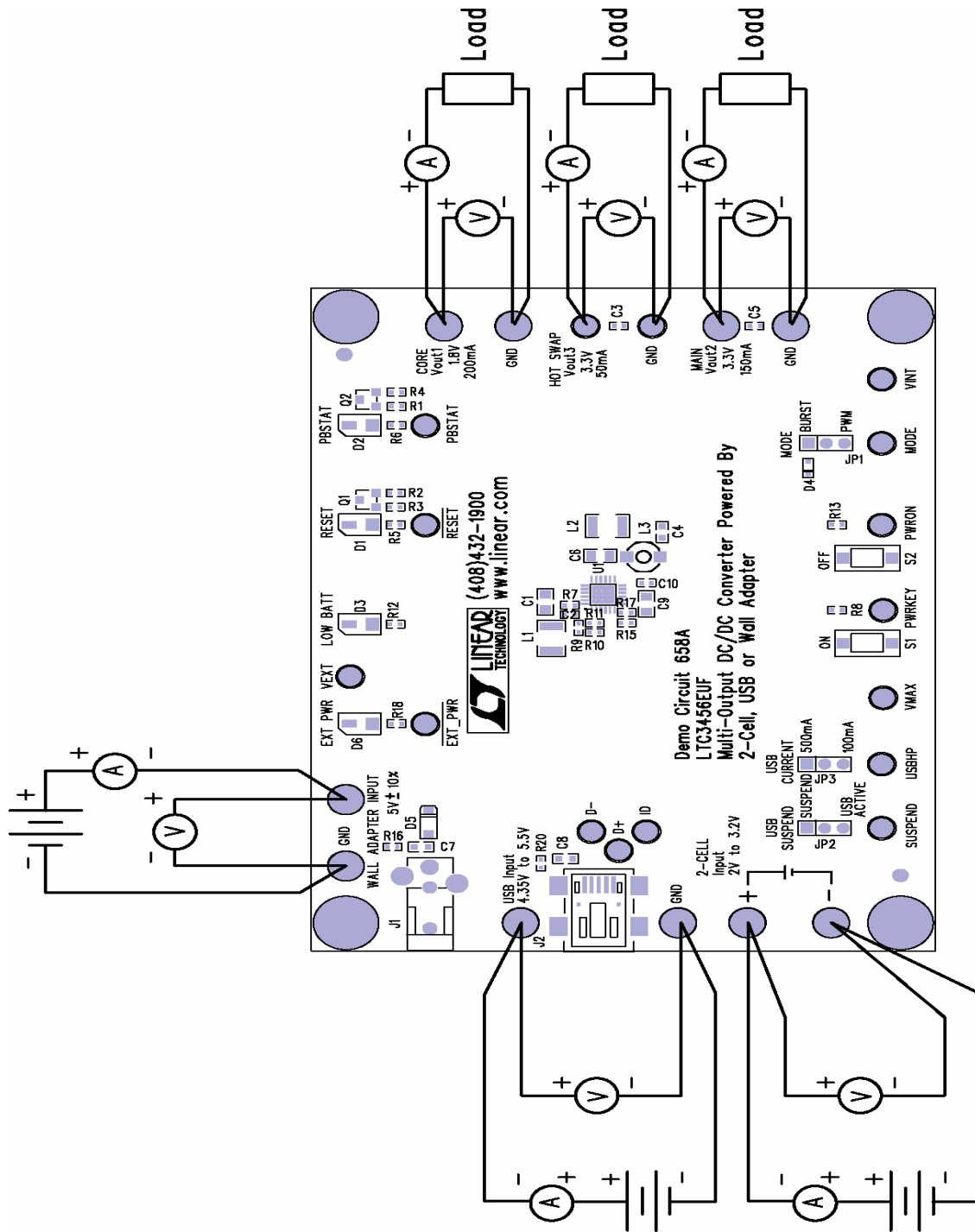

Figure 1. Proper Measurement Equipment Setup

QUICK START GUIDE FOR DEMONSTRATION CIRCUIT 658

MULTI-OUTPUT DC/DC CONVERTER POWERED BY 2-CELL, USB OR WALL ADAPTER

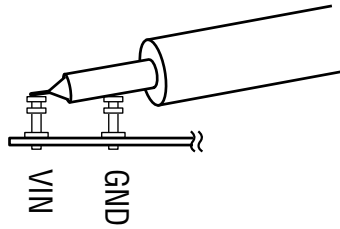
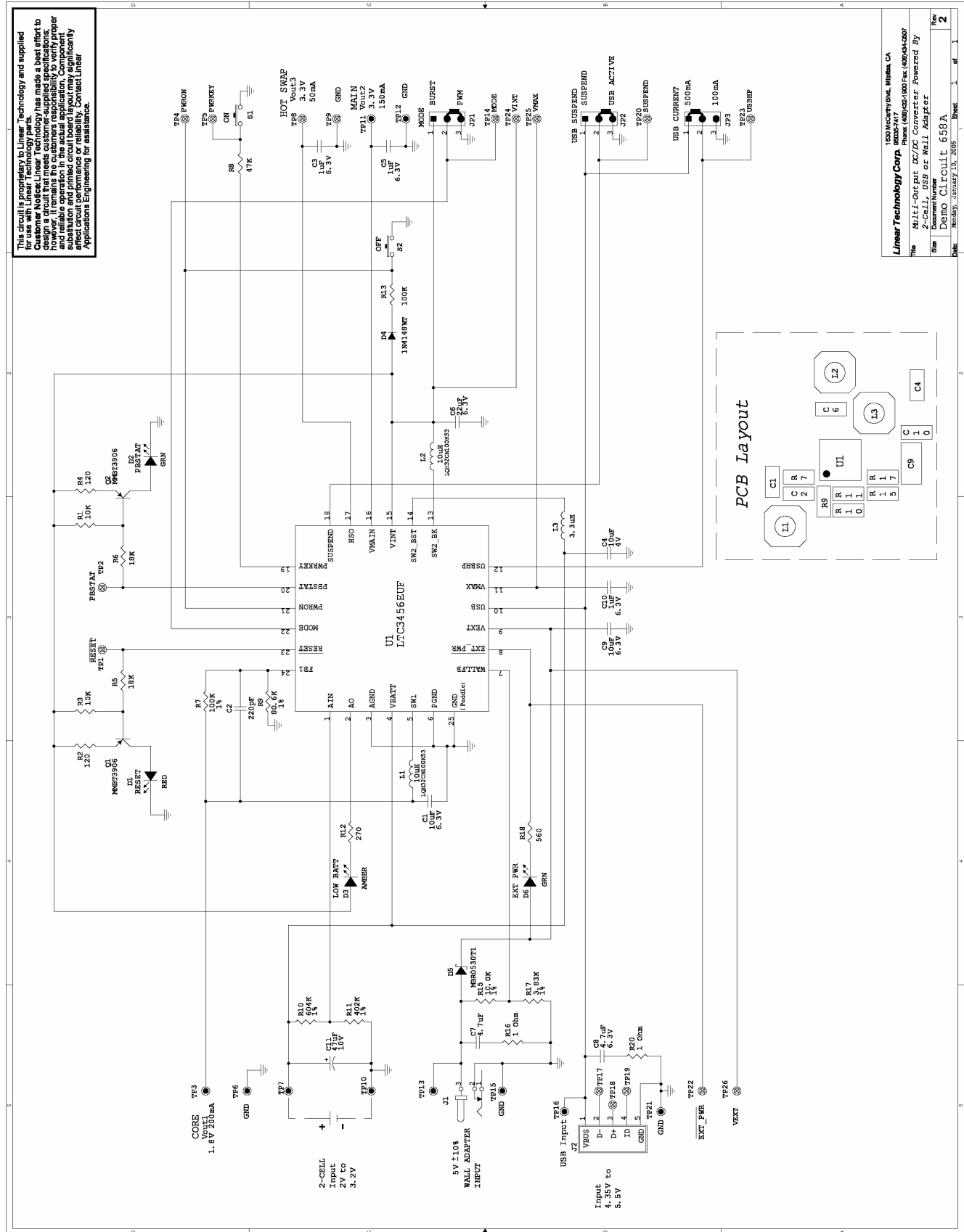

Figure 2. Measuring Input or Output Ripple

QUICK START GUIDE FOR DEMONSTRATION CIRCUIT 658

MULTI-OUTPUT DC/DC CONVERTER POWERED BY 2-CELL, USB OR WALL ADAPTER



Компания «Океан Электроники» предлагает заключение долгосрочных отношений при поставках импортных электронных компонентов на взаимовыгодных условиях!

Наши преимущества:

- Поставка оригинальных импортных электронных компонентов напрямую с производств Америки, Европы и Азии, а так же с крупнейших складов мира;
- Широкая линейка поставок активных и пассивных импортных электронных компонентов (более 30 млн. наименований);
- Поставка сложных, дефицитных, либо снятых с производства позиций;
- Оперативные сроки поставки под заказ (от 5 рабочих дней);
- Экспресс доставка в любую точку России;
- Помощь Конструкторского Отдела и консультации квалифицированных инженеров;
- Техническая поддержка проекта, помощь в подборе аналогов, поставка прототипов;
- Поставка электронных компонентов под контролем ВП;
- Система менеджмента качества сертифицирована по Международному стандарту ISO 9001;
- При необходимости вся продукция военного и аэрокосмического назначения проходит испытания и сертификацию в лаборатории (по согласованию с заказчиком);
- Поставка специализированных компонентов военного и аэрокосмического уровня качества (Xilinx, Altera, Analog Devices, Intersil, Interpoint, Microsemi, Actel, Aeroflex, Peregrine, VPT, Syfer, Eurofarad, Texas Instruments, MS Kennedy, Miteq, Cobham, E2V, MA-COM, Hittite, Mini-Circuits, General Dynamics и др.);

Компания «Океан Электроники» является официальным дистрибьютором и эксклюзивным представителем в России одного из крупнейших производителей разъемов военного и аэрокосмического назначения «**JONHON**», а так же официальным дистрибьютором и эксклюзивным представителем в России производителя высокотехнологичных и надежных решений для передачи СВЧ сигналов «**FORSTAR**».



JONHON

«**JONHON**» (основан в 1970 г.)

Разъемы специального, военного и аэрокосмического назначения:

(Применяются в военной, авиационной, аэрокосмической, морской, железнодорожной, горно- и нефтедобывающей отраслях промышленности)

«**FORSTAR**» (основан в 1998 г.)

ВЧ соединители, коаксиальные кабели,
кабельные сборки и микроволновые компоненты:

(Применяются в телекоммуникациях гражданского и специального назначения, в средствах связи, РЛС, а так же военной, авиационной и аэрокосмической отраслях промышленности).



Телефон: 8 (812) 309-75-97 (многоканальный)

Факс: 8 (812) 320-03-32

Электронная почта: ocean@oceanchips.ru

Web: <http://oceanchips.ru/>

Адрес: 198099, г. Санкт-Петербург, ул. Калинина, д. 2, корп. 4, лит. А