

High Efficiency USB Power Manager + Dual Buck + Boost + Buck-Boost DC/DC

DESCRIPTION

Demonstration Circuit 1306 is a High Efficiency USB Power Manager plus Dual Buck plus Multi-Output Power Supply featuring the LTC[®]3586. The LTC3586 integrates a high efficiency USB Li-Ion battery charger with PowerPath control and four general purpose switching regulators, all in one chip. The PowerPath manager includes a synchronous switching low voltage input regulator, a full-featured battery charger and an ideal diode. Designed specifically for USB applications, the LTC3586's low voltage switching regulator automatically limits its input current to a maximum of either 1x (for USB 100mA), 5x (for USB 500mA) or 10x for wall-powered applications (1A). The switching input stage provides power to VOUT where power sharing between the application circuit and the battery charger is managed.

Unlike linear PowerPath controllers, the LTC3586's switching input stage can use nearly all of the 0.5W or 2.5W available from the USB port with minimal power dissipation. This feature allows the LTC3586 to provide more power to the application and eases thermal issues in constrained applications. An ideal diode ensures that system power is available from the battery when the input current limit is reached or if the USB or wall supply is removed. The LTC3586 includes two 400mA buck regulators, one 1A buck-boost regulator and one 800mA boost regulator for a variety of handheld applications.

Design files for this circuit board are available. Call the LTC factory.

 LTC, LTM, LT, Burst Mode, are registered trademarks of Linear Technology Corporation. All other trademarks are the property of their respective owners.

TABLE 1. Typical Specifications (25°C)

Input Voltage Range: V _{CC}	4.35V to 5.5V
VOUT	3.4V to 4.7V, 1.5A (Max)
LDO3V3	3.1V to 3.5V, 25mA (Max) Buck
VOUT1	1.16V to 1.26V, 400mA (Max) Buck
VOUT2	1.69V to 1.90V, 400mA (Max) Buck
VOUT3	3.13V to 3.51, 1.0A (Max) Buck-Boost
VOUT4	4.74V to 5.26V 800mA (Max) Boost

OPERATING PRINCIPLES

The LTC3586 is a highly integrated power management IC which includes a high efficiency switch mode PowerPath controller, a battery charger, an ideal diode, an always-on LDO, two 400mA buck switching regulators, a 1A buck-boost switching regulator, and an 800mA boost switching regulator. All of the regulators can be independently controlled via ENABLE pins.

Designed specifically for USB applications, the PowerPath controller incorporates a precision average input current buck switching regulator to make maximum use of the allowable USB power. Because power is conserved, the LTC3586 allows the load current on VOUT to exceed the current drawn by the USB port without exceeding the USB load specifications.

The PowerPath switching regulator and battery charger communicate to ensure that the input current never violates the USB specifications.

The ideal diode from BAT to VOUT guarantees that ample power is always available to VOUT even if there is insufficient or absent power at VBUS.

An “always on” LDO provides a regulated 3.3V from available power at VOUT. Drawing very little quiescent current, this LDO will be on at all times and can be used to supply up to 20mA.

Along with constant frequency PWM mode, the buck and the buck-boost switching regulators have a low power burst mode setting for significantly reduced quiescent current under light load conditions.

QUICK START PROCEDURE

Using short twisted pair leads for any power connections and with all loads and power supplies off, refer to Figure 1 for the proper measurement and equipment setup. The Battery should not be connected to the circuit until told to do so in the procedure below.

When measuring the input or output voltage ripple, care must be taken to avoid a long ground lead on the oscilloscope probe. Measure the input or output voltage ripple by touching the probe tip directly across the VCC or VOUT and GND terminals. See Figure 2 for proper scope probe technique.

1. Jumper, PS and LOAD Settings to start:

JP1 (NTC) = INT	PS1 = OFF
JP2 (ILIM0) = 0	PS2 = NC
JP3 (ILIM1) = 0	LOAD1 = OFF
JP4 (MODE) = 0	LOAD2 = OFF
JP5 (EN1) = OFF	LOAD3 = OFF
JP6 (EN2) = OFF	LOAD4 = OFF
JP7 (EN3) = OFF	LOAD5 = OFF
JP8 (EN4) = OFF	LOAD6 = OFF
NC: Not Connected	

2. Turn on PS1 and slowly increase voltage until the voltage at VBUS is 4.35V while monitoring input current. If input current exceeds 200mA turn off PS1 and look for shorts.
3. Turn on LOAD1 and LOAD2. Set LOAD1 on LDO3V3 to 5mA and LOAD2 on VOUT to 50mA in constant current mode.

4. Verify the DC voltage levels on LDO3V3 as ~3.3V, VOUT as ~4.5V and BAT as ~4.3V.
5. Continue to increase PS1 until the voltage at VBUS is 5.0V and verify the DC voltages on LDO3V3 as ~3.3V, VOUT as ~4.5V and BAT as ~4.3V.
6. Set LOAD1 to 25mA and increase LOAD2 while monitoring the input current. Verify the input limit current of ~100mA when VOUT drops below 3.4V.
7. A. Repeat with JP3 (ILIM1) and JP2 (ILIM0) in the 1 position. Verify the input limit current of ~500mA
B. Repeat with JP3 (ILIM1) in the 0 position and JP2 (ILIM0) in the 1 position. Verify the input limit current of ~900mA
8. Set LOAD1 to 1mA and LOAD2 to 0mA then set JP3 (ILIM1) to the 1 position and JP2 (ILIM0) to the 0 position. Verify the DC voltage levels on LDO3V3 as <0.5V, VOUT as < 1.0V and BAT as <VOUT.
9. Set JP3 (ILIM1) in the 0 position and JP2 (ILIM0) in the 1 position.
10. Set LOAD1 to 25mA and LOAD2 to 750mA while monitoring the input current. Verify the DC output voltage on LDO3V3 as 3.3V, VOUT as 4.3V and BAT as VOUT- ~0.3V.
11. Adjust LOAD2 until I_{in} is 500mA. Verify the DC voltage levels at NTC as ~2.5V, CLPROG as ~0.7V and PROG of <10mV. Verify that the FAULT and CHRG LEDs are off.
12. Adjust LOAD1 to 5mA and LOAD2 to 50mA. Set jumper JP5 (EN1) to ON position and adjust LOAD3 to 50mA. Verify the DC voltage level on VOUT1 as ~1.2V.
13. Increase LOAD3 to 400mA and verify the DC voltage level as 1.2V. Adjust LOAD3 to 50mA.
14. Set jumpers JP5 (EN1) to the OFF position, JP6 (EN2) to the ON position and adjust LOAD4 to 50mA. Verify the DC voltage on VOUT2 of ~1.8V.
15. Increase LOAD4 to 400mA and verify the DC voltage level on VOUT2 as ~1.8V. Adjust LOAD4 to 50mA.
16. Set jumpers JP6 (EN2) to the OFF position, JP7 (EN3) to the ON position and adjust LOAD5 to 50mA. Verify the DC voltage level VOUT3 as ~3.3V.
17. Increase LOAD5 to 750mA and verify the DC voltage level on VOUT3 as ~3.3V. Adjust LOAD5 to 50mA.
18. Set jumpers JP7 (EN3) to the OFF position, JP8 (EN4) to the ON position and adjust LOAD6 to 50mA. Verify the DC voltage level on VOUT4 as ~5.0V.
19. Increase LOAD6 to 600mA and verify the input current, the DC voltage level on VOUT4 as ~5.0V. Adjust LOAD6 to 50mA.
20. Set jumper JP8 (EN4) to the OFF position.
21. Turn on PS2 and adjust until the voltage at BAT is 3.6V. Verify the I_{in} from PS1 is ~450mA and the charging current going into PS2 is ~500mA. Verify that the CHRG LED is ON. Verify the DC voltage on VOUT is ~3.9V and VPROG is ~1.0V.
22. Adjust PS2 until the voltage at BAT is 4.3V. Verify the I_{in} from PS1 is ~65mA and charging current going into PS2 is <10mA. Verify that the CHRG LED is OFF. Verify the DC voltage on VOUT is ~4.6V and VPROG is <10mV.

23. Set Jumpers

JP5 (EN1) = ON

JP6 (EN2) = ON

JP7 (EN3) = ON

JP8 (EN4) = ON

Verify LOAD1 is set to 5mA and LOAD2 – LOAD5 are set to 50mA. Verify that LDO3V3, VOUT, VOUT1, VOUT2, VOUT3 and VOUT4 are enabled.

24. Using a jumper wire short the FAULT turret to a GND turret. Verify that LDO3V3 and VOUT are enabled and that VOUT1, VOUT2, VOUT3 and VOUT4 outputs are disabled. Remove the short.

25. Turn PS1 and PS2 off, wait 15 seconds and turn PS2 on and then turn PS1 on. Verify that LDO3V3, VOUT, VOUT1, VOUT2, VOUT3 and VOUT4 are enabled.

26. Verify PS2 is set at 4.3V. Adjust PS1 to 4.2V. Verify DC voltage levels on LDO3V3, VOUT, VOUT1, VOUT2, VOUT3 and VOUT4 are enabled. Verify the current is sourced from PS2. Set PS2 to 3.8V.

27. Set jumper JP1 (NTC) to EXT. Connect a 51K resistor between the NTC turret and a GND turret. The CHRG LED will blink slowly at a 1.5 Hz rate and verify that the charging current going into PS2 is ~0mA.

28. Set jumper JP1 (NTC) to EXT. Connect a 330K resistor between the NTC turret and a GND turret. The CHRG LED will blink slowly at a 1.5 Hz rate and verify that the charging current going into PS2 is ~0mA.

29. Set jumper JP1 to INT.

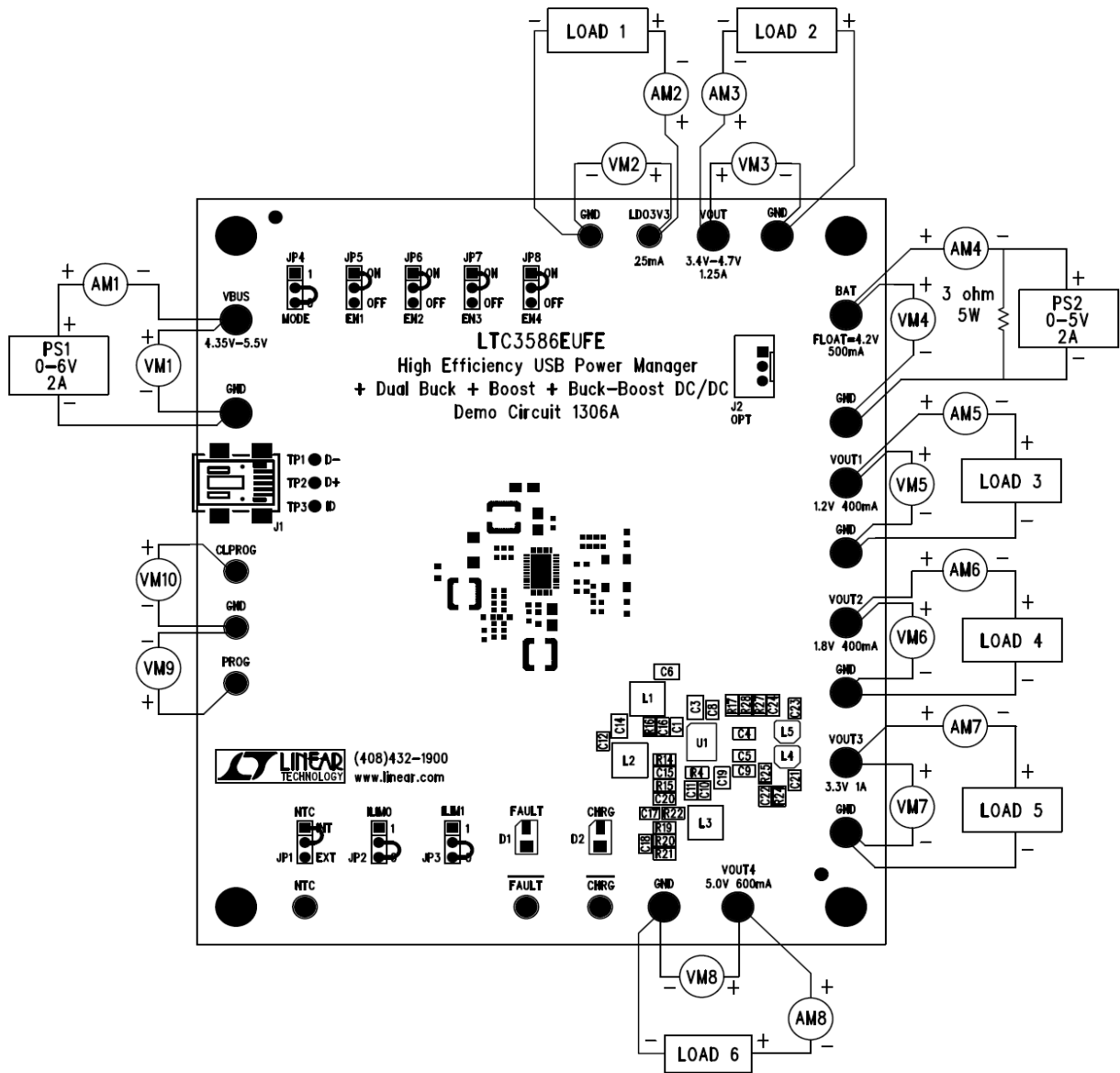

Figure 1. Proper Measurement Equipment Setup

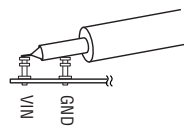

Figure 2. Measuring Input or Output Ripple

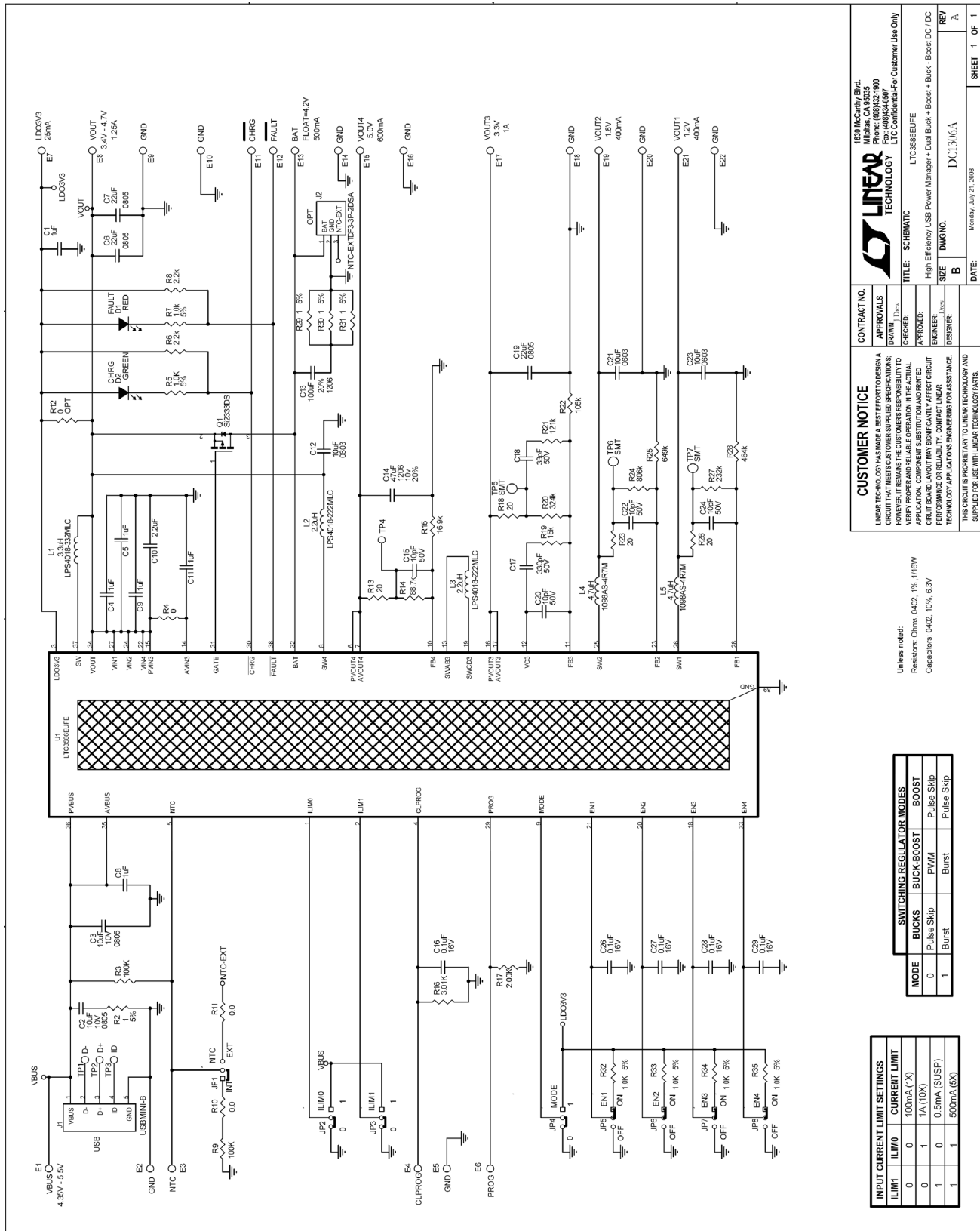

Figure 3. Circuit Schematic

Item	Qty	Reference - Des	Part Description	Manufacturer, Part #
REQUIRED CIRCUIT COMPONENTS:				
1	1	C3	CAP, CHIP X5R, 10uF, 10V, 0805	MURATA, GRM21BR61A106KE19
2	3	C12,C21,C23	CAP, CHIP,X5R, 10uF, 6.3V, 0603	TDK, C1608X5R0J106M
3	6	C1, C4,C5,C8,C9,C11	CAP, CHIP,X5R, 1uF, 6.3V, 0402	TDK, C1005X5R0J105M
4	1	C10	CAP, CHIP,X5R, 2.2uF, 6.3V, 0603	TDK, C1608X5R0J225M
5	3	C6,C7,C19	CAP, CHIP, X5R, 22uF, 6.3V, 0805	TAIYO YUDEN, JMK212BJ226MG-T
6	1	C14	CAP, CHIP, X5R, 47uF, 10V, 1206	TAIYO YUDEN, LMK316BJ476ML-T
7	4	C15,C20,C22,C24	CAP, CHIP, COG, 10pF, 50v, 0402	AVX, 04025A100KAT
8	1	C18	CAP, CHIP, COG, 33pF, 50v, 0402	AVX, 04025A330KAT
9	1	C17	CAP, CHIP, COG, 330pF, 50v, 0402	AVX, 04025A331KAT
10	5	C16,C26,C27,C28, C29	CAP, CHIP, X5R, 0.1uF, 16V, 0402	TDK, C1005X5R1C104K
11	2	L2,L3	INDUCTOR, 2.2uH, 0.070 Ohms, 2.3A	COILCRAFT, LPS4018-222MLC
12	1	L1	INDUCTOR, 3.3uH, 0.080 Ohms, 2.0A	COILCRAFT, LPS4018-332MLC
13	2	L4,L5	INDUCTOR, 4.7uH, 0.155 Ohms, 0.88A	TOKO, 1098AS-4R7M
14	1	R17	RES, 0402, 2.0K OHMS, 1%, 1/16w	VISHAY, CRCW04022K00FKED
15	2	R6,R8	RES, 0402, 2.2K OHMS, 1%, 1/16w	VISHAY, CRCW04022K20FKED
16	1	R16	RES, 0402, 3.01K OHMS, 1%, 1/16w	VISHAY, CRCW04023K01FKED
17	1	R19	RES, 0402, 15K OHMS, 1%, 1/16w	VISHAY, CRCW040215K0FKED
18	1	R15	RES, 0402, 16.9K OHMS, 1%, 1/16w	VISHAY, CRCW040216K9FNED
19	1	R27	RES, 0402, 232K OHMS, 1%, 1/16w	VISHAY, CRCW0402232KFKED
20	1	R20	RES, 0402, 324K OHMS, 1%, 1/16w	VISHAY, CRCW0402324KFKED
21	1	R28	RES, 0402, 464K OHMS, 1%, 1/16w	VISHAY, CRCW0402464KFKED
22	1	R25	RES, 0402, 649K OHMS, 1%, 1/16w	VISHAY, CRCW0402649KFKED
23	1	R24	RES, 0402, 806K OHMS, 1%, 1/16w	VISHAY, CRCW0402806KFKED
24	1	R14	RES, 0402, 88.7K OHMS, 1%, 1/16w	VISHAY, CRCW0402887KFKED
25	1	R21	RES, 0402, 121K OHMS, 1%, 1/16w	VISHAY, CRCW0402121KFKED
26	1	R22	RES, 0402, 105K OHMS, 1%, 1/16w	VISHAY, CRCW0402105KFKED
27	3	R4,R10,R11	RES, 0402, 0.0 Ohms, 1/16w	VISHAY, CRCW04020000FKED
28	2	R3,R9	RES, 0402, 100K Ohms, 1%, 1/16w	VISHAY, CRCW0402100KFKED
29	4	R32,R33,R34,R35	RES, 0402, 1K OHM, 5%, 1/16w	VISHAY, CRCW04021K00JNED
30	1	Q1	MOSFET PCHAN., 12v	VISHAY SILICONIX, SI2333DS
31	1	U1	High Efficiency USB Power Manager + Dual Buck + Boost + Buck-Boost DC/DC	LINEAR TECH, LTC3586EUFE
ADDITIONAL COMPONENTS FOR DEMO BOARD ONLY				
1	1	C2	CAP, CHIP, X5R, 10uF, 10V, 0805	MURATA, GRM21BR61A106KE19
2	1	C13	CAP, CHIP, X5R, 100uF, 6.3V, 1206	MURATA, GRM31CR60J107ME39L
3	1	D1	LED, RED	PANASONIC, LN1251-C-TR
4	1	D2	LED, GRN	PANASONIC, LN1351-C-TR
5	2	R5,R7	RES, 0402, 1K OHM, 5%, 1/16w	VISHAY, CRCW04021K00JNED
6	4	R13,R18,R23,R26	RES, 0402, 20 OHM, 1%, 1/16w	VISHAY, CRCW040220R0FKED
7	4	R2,R29,R30,R31	RES, 0402, 1 OHM, 5%, 1/16w	VISHAY, CRCW04021R00JNED
OPTIONAL COMPONENTS FOR DEMO BOARD ONLY:				
1	0	R12	RES, 0402, 0.0 Ohms, 1/16w	VISHAY, CRCW04020000FKED
HARDWARE FOR DEMO BOARD ONLY:				
1	8	JP1,JP2,JP3, JP4, JP5,JP6,JP7,JP8	HEADER,3 PINS, 2mm	SAMTEC, TMM-103-02-L-S
2	8	JP1,JP2,JP3, JP4, JP5,JP6,JP7,JP8	SHUNT, 2mm	SAMTEC, 2SN-BK-G
3	1	J1	CONN, USB MINI-A	TYCO, 440247-1
4	1	J2	HEADER,3 PINS	HIROSE ELECTRIC, DF3A-3P-2DSA
5	14	E1,E2,E8,E9,E13,E14, E15,E16,E17,E18,E19,E20,E21,E22	TURRET, 0.09 DIA	MILL-MAX, 2501-2
6	8	E3,E4,E5,E6,E7, E10, E11,E12	TURRET, 0.061 DIA	MILL-MAX, 2308-2
7	4		STAND-OFF, NYLON 0.375" tall (SNAP ON)	KEYSTONE, 8832 (SNAP ON)

Figure 4. Bill of Materials

Компания «Океан Электроники» предлагает заключение долгосрочных отношений при поставках импортных электронных компонентов на взаимовыгодных условиях!

Наши преимущества:

- Поставка оригинальных импортных электронных компонентов напрямую с производств Америки, Европы и Азии, а так же с крупнейших складов мира;
- Широкая линейка поставок активных и пассивных импортных электронных компонентов (более 30 млн. наименований);
- Поставка сложных, дефицитных, либо снятых с производства позиций;
- Оперативные сроки поставки под заказ (от 5 рабочих дней);
- Экспресс доставка в любую точку России;
- Помощь Конструкторского Отдела и консультации квалифицированных инженеров;
- Техническая поддержка проекта, помощь в подборе аналогов, поставка прототипов;
- Поставка электронных компонентов под контролем ВП;
- Система менеджмента качества сертифицирована по Международному стандарту ISO 9001;
- При необходимости вся продукция военного и аэрокосмического назначения проходит испытания и сертификацию в лаборатории (по согласованию с заказчиком);
- Поставка специализированных компонентов военного и аэрокосмического уровня качества (Xilinx, Altera, Analog Devices, Intersil, Interpoint, Microsemi, Actel, Aeroflex, Peregrine, VPT, Syfer, Eurofarad, Texas Instruments, MS Kennedy, Miteq, Cobham, E2V, MA-COM, Hittite, Mini-Circuits, General Dynamics и др.);

Компания «Океан Электроники» является официальным дистрибьютором и эксклюзивным представителем в России одного из крупнейших производителей разъемов военного и аэрокосмического назначения «JONHON», а так же официальным дистрибьютором и эксклюзивным представителем в России производителя высокотехнологичных и надежных решений для передачи СВЧ сигналов «FORSTAR».



JONHON

«JONHON» (основан в 1970 г.)

Разъемы специального, военного и аэрокосмического назначения:

(Применяются в военной, авиационной, аэрокосмической, морской, железнодорожной, горно- и нефтедобывающей отраслях промышленности)

«FORSTAR» (основан в 1998 г.)

ВЧ соединители, коаксиальные кабели, кабельные сборки и микроволновые компоненты:

(Применяются в телекоммуникациях гражданского и специального назначения, в средствах связи, РЛС, а так же военной, авиационной и аэрокосмической отраслях промышленности).



Телефон: 8 (812) 309-75-97 (многоканальный)

Факс: 8 (812) 320-03-32

Электронная почта: ocean@oceanchips.ru

Web: <http://oceanchips.ru/>

Адрес: 198099, г. Санкт-Петербург, ул. Калинина, д. 2, корп. 4, лит. А