

INTRODUCTION

Amphenol is a leading designer, manufacture and marketer of interconnection solutions since 1972. Amphenol is the first Company in India who started manufacturing high performance connectors. These expertise and capabilities enables us to turn your interconnection problems to solutions

Amphenol Back Shells and Accessories are developed for environmental protection needs of circular connectors. These are designed to meet the requirements of military standards. The Military numbers indicated in this catalogue are for reference only.

This catalogue describes the standard and special purpose designs used in Military and industrial circular connectors meeting the following specifications.

MIL-C-5015
MIL-C-26482
MIL-C-38999
MIL-C-55116

Index

Contents	Page
Series 62 IN	2
Series MS/97/97B	10
Series MS347 & MS Crimp	17
Series 38999	24
Series 164	31

SERIES 62IN

These are the accessories compatible with miniature circular bayonet-coupled connectors according to MIL-C-26482 Series 1. The standard finishes of these accessories are Cadmium with olive drab chromate. Other alternate finishes are also available on request.

62IN-584	Grommet seal & nut
62IN-585	Grommet seal & nut with Strain Relief Clamp
62IN-720	Clamp for Unscreened jacketed cable
62IN-776	General duty shell
62IN-736	Cap with chain for single hole mounting Receptacle
62IN-737	Cap with chain for cable Receptacle
62IN-738	Cap with chain for flange mounting Receptacle
62IN-742	Cap with chain for plug
62IN-810	Cap with Chord for plug
62IN-812	Cap with Chord fo flange Receptacle
62IN-813	Cap with Chord for single hole mount Receptacle
62IN-814	Cap with Chord for cable Receptacle
62IN-760	Flange mounting gasket
62IN-pg	PG Adapter

62IN - 584 - XX - XXS or P

Grommet seal and nut provides an environmental for the exposed solder buckets in the open back class T shells.

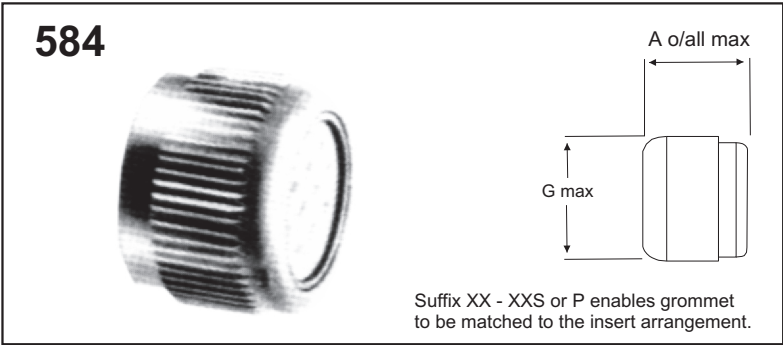

Shell Size	A	G max
08	13.84	14.25
10	13.84	17.43
12	13.84	20.60
14	13.84	23.78
16	13.84	26.95
18	13.84	30.13
20	13.84	33.30
22	13.84	36.75
24	12.73	39.65

62IN - 585 XX- XXS or P

Grommet and nut with strain relief clamp. The clamp prevents the flexing of the wires in the immediate vicinity of the risers, so avoiding the risk of leaks.

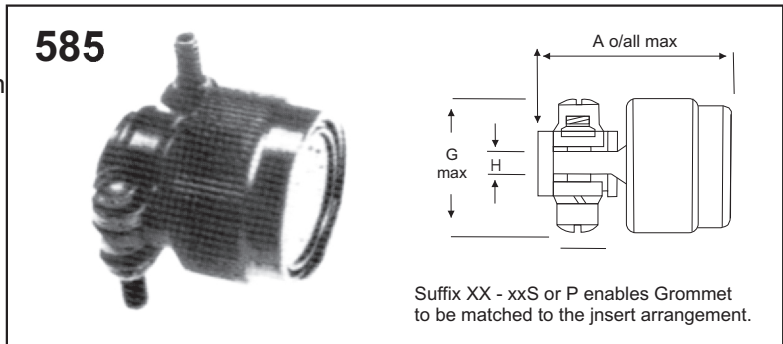

Shell Size	A max	G max	H max
08	25.17	21.03	4.09
10	25.17	22.63	4.90
12	25.17	25.81	8.05
14	24.51	28.98	9.65
16	28.07	36.22	16.00
18	28.07	36.22	16.00
20	32.64	36.22	16.00
22	32.64	39.80	19.18
24	34.88	44.07	20.45

62IN - 720 - XX

Clamp for unscreened jacketed cable
No grommet is supplied, for use with
50T, 51T and 56T styles.

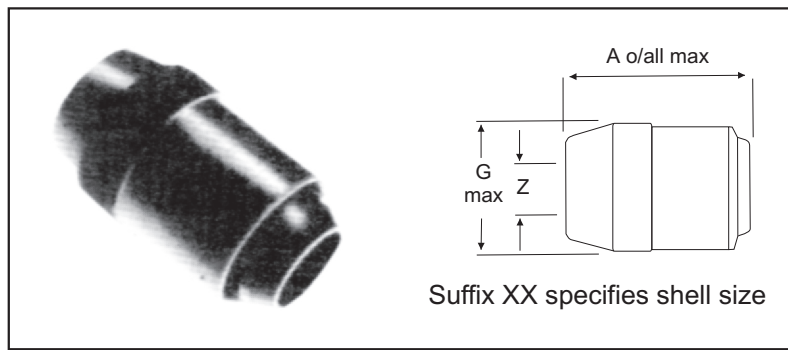

Shell Size	A max	G max	Z	
			closed	free
08	27.56	14.25	4.28	5.84
10	26.92	17.43	5.21	7.93
12	29.46	20.60	8.59	11.23
14	34.54	23.78	10.57	13.69
16	40.26	26.95	13.97	15.65
18	45.34	30.13	15.24	17.57
20	50.32	33.30	16.13	18.98
22	55.39	36.75	17.02	21.49
24	56.28	39.65	18.80	22.71

62IN -776

General duty shell to accept conduit,
AN 3057 or
MS 3057 A cable clamps and heat
shrink sleeves.

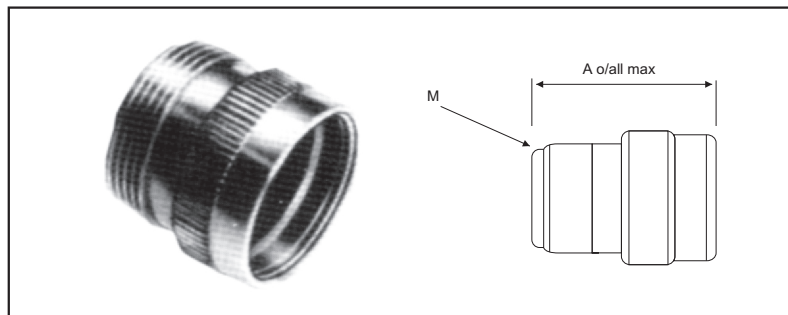

Shell Size	A Max	M Thred
08	23.80	1/2 - 28 UNEF
10	23.80	5/8 - 24 NEF
12	23.8	3/4 - 20 UNEF
14	23.80	7/8 - 20 UNEF
16	23.8	1 -20 UNEF
18	23.80	1.3/16 -18 NEF
20	23.8	1.3/16 - 18 NEF
22	23.80	1.7/16 - 18 NEF
24	23.8	1.7/16 - 18 NEF

62IN - 736
 Cap and chains for single hole
 mounting receptacles

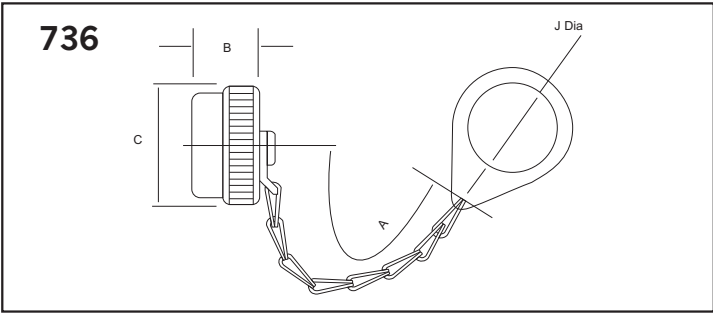

Shell Size	A -6.35	B -0.13	C DIA MAX	J + 0.127
08	76.2	13.23	18.64	14.68
10	76.2	13.23	21.82	17.86
12	88.9	13.23	25.4	22.63
14	88.9	13.23	28.57	25.81
16	88.9	13.23	31.75	29.39
18	88.9	13.23	34.92	32.16
20	101.6	13.23	38.1	35.33
22	101.6	13.23	41.27	38.51
24	101.6	14.12	44.45	41.68

62IN - 737
 Caps and chains for cable
 mounting receptacles

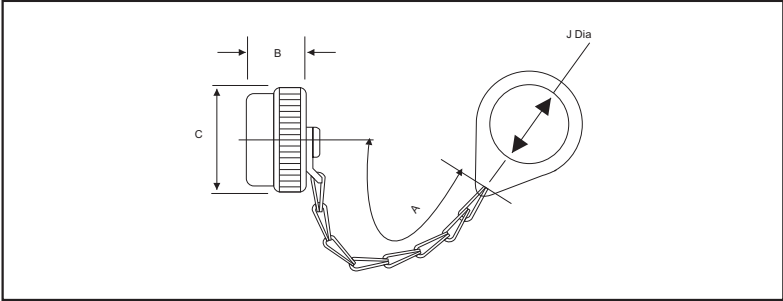

Shell Size	A -6.35	B -0.13	C DIA MAX	J - 0.127
08	76.2	15.21	18.64	11.63
10	76.2	15.21	21.82	14.81
12	88.9	15.21	25.4	17.98
14	88.9	15.21	28.57	22.76
16	88.9	15.21	31.75	25.93
18	88.9	15.21	34.92	29.11
20	101.6	15.21	38.1	32.28
22	101.6	15.21	41.27	35.46
24	101.6	15.21	44.45	38.63

62IN - 736

Caps and chains for flange mounting receptacles.

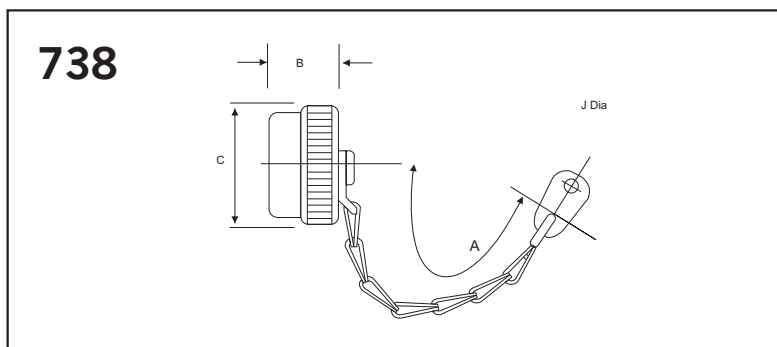

Shell Size	A - 6.35	B - 0.13	C dia max	J -0.127
08	76.2	13.23	18.64	3.18
10	76.2	13.23	21.82	3.18
12	88.9	13.23	25.4	3.18
14	88.9	13.23	28.57	3.18
16	88.9	13.23	31.75	3.18
18	88.9	13.23	34.92	3.18
20	101.6	13.23	38.1	3.18
22	101.6	13.23	41.27	3.18
24	101.6	14.12	44.45	3.86

62IN - 742

Caps and chains for plugs.

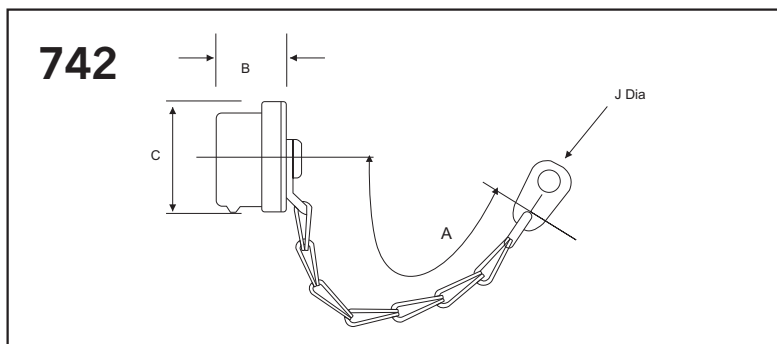

Shell Size	A - 6.35	B - 0.13	C dia max	J -0.127
08	76.2	13.25	18.26	3.18
10	76.2	13.25	21.43	3.18
12	88.9	13.25	25.4	3.18
14	88.9	13.25	28.57	3.18
16	88.9	13.25	31.75	3.18
18	88.9	13.25	34.92	3.18
20	101.6	14.83	38.1	3.18
22	101.6	14.83	41.27	3.18
24	101.6	15.67	44.45	3.86

62IN - 810
Caps and cords for plugs

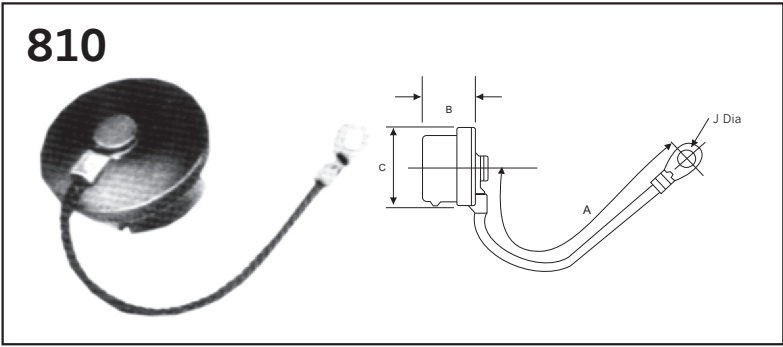

Shell Size	A - 6.35	B - 0.13	C dia max	J -0.8
08	76.2	13.25	18.26	3.68
10	76.2	13.25	21.43	3.68
12	88.9	13.25	25.4	3.68
14	88.9	13.25	28.57	3.68
16	88.9	13.25	31.75	3.68
20	101.6	14.83	38.1	3.68
22	101.6	14.83	41.27	3.68
24	101.6	15.67	44.45	4.34

62IN - 812
Caps and cords for flange mounting receptacles.

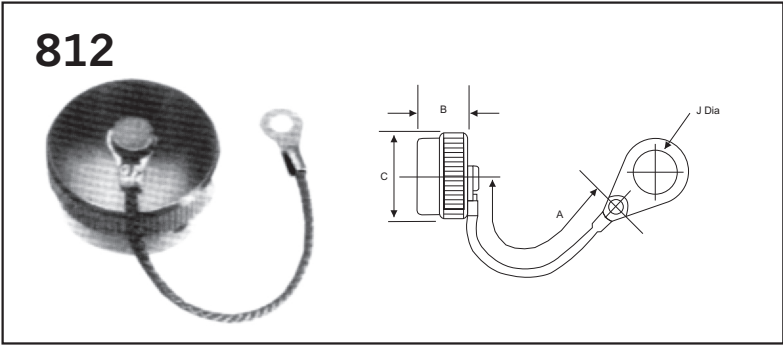

Shell Size	A - 6.35	B - 0.13	C dia max	J -0.08
08	76.2	13.23	18.64	3.68
10	76.2	13.23	21.82	3.68
12	88.9	13.23	25.4	3.68
14	88.9	13.23	28.57	3.68
16	88.9	13.23	31.75	3.68
18	88.9	13.23	34.92	3.68
20	101.6	13.23	38.1	3.68
22	101.6	13.23	41.27	3.68
24	101.6	14.12	44.45	4.34

62IN - 813

Caps and cords for single hole mounting receptacles.

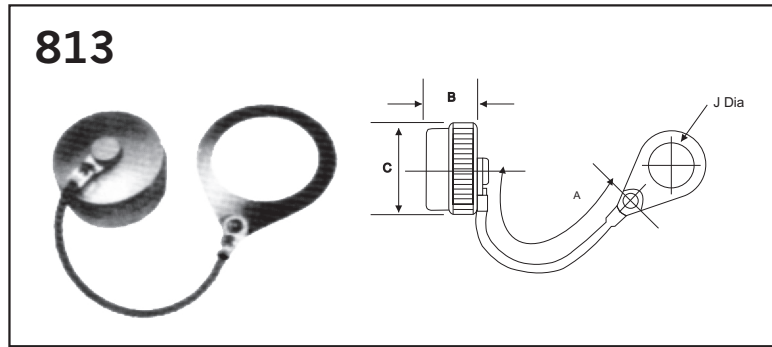

Shell Size	A - 6.35	B - 0.13	C dia max	J -0.25
08	76.2	13.23	18.64	14.68
10	76.2	13.23	21.82	17.86
12	88.9	13.23	25.4	22.63
14	88.9	13.23	28.57	25.81
16	88.9	13.23	31.75	29.39
18	88.9	13.23	34.92	32.15
20	101.6	13.23	38.1	35.33
22	101.6	13.23	41.27	38.51
24	101.6	14.12	44.45	41.68

62IN - 814

Caps and cords for cable mounting receptacles.

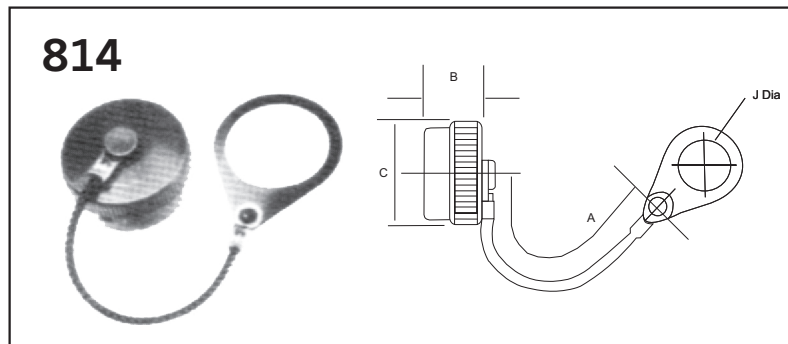

Shell Size	A - 6.35	B - 0.13	C dia max	J -0.25
08	76.2	13.23	18.26	11.50
10	76.2	13.23	21.43	14.64
12	88.9	13.23	25.4	17.85
14	88.9	13.23	28.57	22.63
16	88.9	13.23	31.75	25.80
18	88.9	13.23	34.92	28.98
20	101.6	13.23	38.1	32.15
22	101.6	13.23	41.27	35.33
24	101.6	14.12	44.45	38.50

62IN - 760

Flange mounting gasket for box mounting and hermetic receptacles.

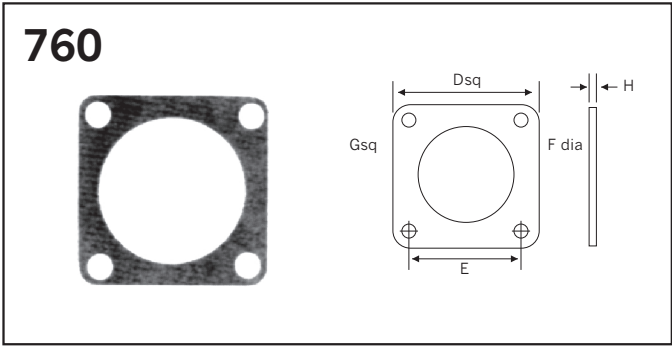

Shell Size	D ±0.254	E ±0.254	F ±0.20	G +0.254	H
08	20.62	15.08	12.90	3.30	1.06/0.40
10	23.82	18.26	16.07	3.30	1.06/0.40
12	26.18	20.65	19.25	3.30	1.06/0.40
14	28.57	23.01	22.42	3.30	1.06/0.40
16	30.96	24.61	25.60	3.30	1.06/0.40
18	33.32	27.00	28.77	3.30	1.06/0.40
20	36.52	29.36	31.95	3.30	1.06/0.40
22	39.70	31.75	35.13	3.30	1.06/0.40
24	42.87	34.92	38.30	3.96	1.06/0.40

PG Adapter

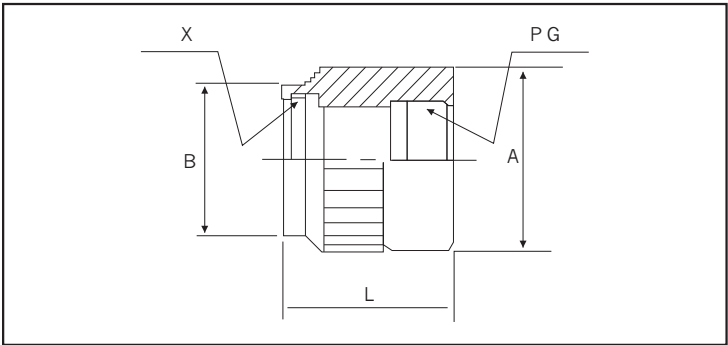

Part No.	For Shell Size	X Thread in inches	A	B	L	PG Thread
62IN08-PG7	8	13.23	16.50	14.50	20.00	PG7
62IN10-PG9	10	13.23	22.00	17.70	20.00	PG9
62IN12-PG9	12	13.23	22.00	21.00	20.00	PG9
62IN14-PG13.5	14	13.23	28.00	23.50	25.00	PG13.5
62IN16-PG9	16	13.23	29.00	27.80	30.00	PG9
62IN20-PG21	20	13.23	35.00	34.00	40.00	PG21

SERIES MS/97/97B

These are the accessories compatible with Threaded-coupled connectors according to MIL-C-5015. The standard finishes of these accessories are Black anodic. Other alternate finishes are also available on request.

MS-3057	Cable Clamp
MS-3420	Telescopic Bush - Neoprene
MS-25042	Cap for Plug
MS-25043	Cap for Receptacle
97B-25042	Cap for Plug
97B-25043	Cap for Receptacle
MS-PG	Pg Adapter
MS-52000	Flange Gasket
MS-3105	Dummy Receptacle
MS	Strain Relief Backshell
MS	Right Angle Backshell

Cable clamp
MS-3057
 Use MS-3420 sleeves

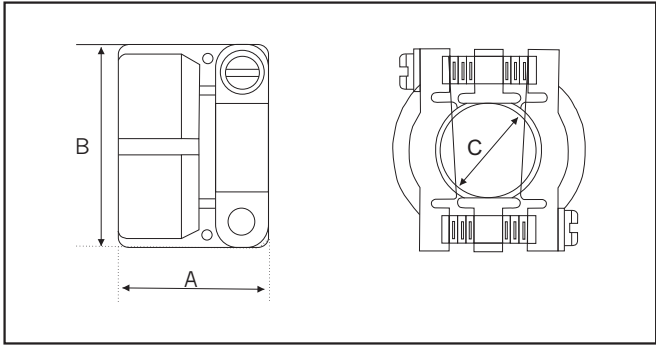

All Dimensions are in mm

Part number	Shell Size	Max OD of cable	A	B	C	Thread in inches
MS-3057-4A	10SL,12S	7.94	20.90	21.39	7.94	5/8-24
MS-3057-6A	14,14S	11.11	21.27	25.27	11.11	3/4-20
MS-3057-8A	16,16S	14.29	23.37	28.45	14.29	7/8-20
MS-3057-10A	18	15.87	23.37	30.89	15.87	1-20
MS-3057-12A	20,22	19.05	23.54	35.64	19.05	1 3/16-18
MS-3057-16A	24,28	23.81	25.78	42.75	23.81	1 7/16-18
MS-3057-20A	32	31.70	28.00	51.00	31.70	1 3/4-18
MS-3057-24A	36	34.92	29.36	57.02	34.92	2-18

Neoprene sleeve
MS-3420
 Rubber bushing Protects wire bundles and unjacketed cable from possible damage by cable clamp.

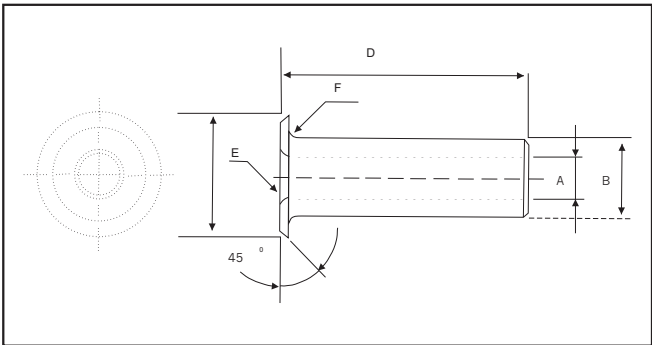

All Dimensions are in mm

Part number	A	B	c	D	E Rad in inches	F Rad in inches
MS-3420-3	3.30	5.33	9.50	73.02	1/32	1/32
MS-3420-4	5.59	7.67	12.70	69.85	1/32	1/32
MS-3420-6	7.92	10.84	15.59	66.67	1/32	1/16
MS-3420-8	11.10	14.02	18.77	63.50	1/16	1/16
MS-3420-10	14.27	15.62	21.94	60.32	1/16	1/16
MS-3420-12	15.87	18.80	26.90	57.15	1/16	1/16
MS-3420-16	19.05	23.54	26.36	53.97	1/16	1/16
MS-3420-20	23.80	31.50	40.41	50.80	1/16	1/16
MS-3420-24	31.75	34.67	46.79	47.62	1/16	1/16

Protective cap for MS and 97 series MS-25042

For Plugs

Has external threads and used on all plugs where a coupling ring is provided

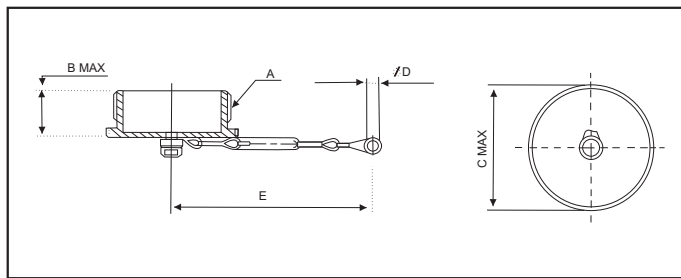

All Dimensions are in mm

MS Part number	For connector size	A Thread in inches	B	C	D	E
MS 25042-10-1	MS 10S-1-SL	5/8-24	16.67	17.4	4	102
MS 25042-12-1	MS 12-12S	3/4-20	21.4	20.6	4	115
MS 25042-14-1	MS 14-14S	7/8-20	21.4	23.7	4	115
MS 25042-16-1	MS 16-16S	1-20	21.4	26.9	4	115
MS 25042-18-1	MS 18	1 1/8-18	21.4	30	4	115
MS 25042-20-1	MS 20	1 1/4-18	21.4	33	4.8	127
MS 25042-22-1	MS 22	1 3/8-18	21.4	36.4	4.8	127
MS 25042-24-1	MS 24	1 1/2-18	21.4	39.6	4.8	140
MS 25042-28-1	MS 28	1 3/4-18	21.4	46	4.8	197
MS 25042-32-1	MS 32	2 1/4-18	21.4	52	5.6	197
MS 25042-36-1	MS 36	2 1/4-186	21.4	58.7	5.6	197
MS 25042-40-1	MS 40	2 1/2-16	21.4	65	5.6	-SLS-197

Protective cap for MS & 97 series MS-25043

For receptacles

Has internal threads & is used on all receptacles. Gasket is provided in the dust cap forming a watertight seal.

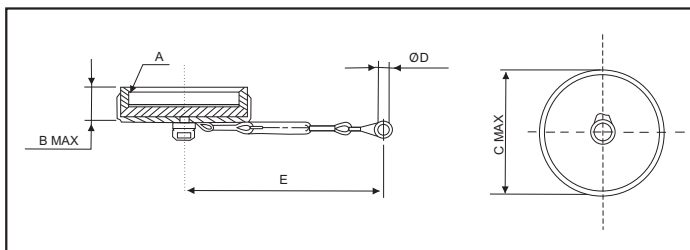

All Dimensions are in mm

MS Part number	For connector size	A Thread in inches	B	C	D	E
MS 25043-10-1	MS 10S-1-SL	5/8-24	11-11	20.7	3.6	102
MS 25043-12-1	MS 12-12S	3/4-20	11-11	25.4	3.6	115
MS 25043-14-1	MS 14-14S	7/8-20	11-11	28.6	3.6	115
MS 25043-16-1	MS 16-16S	1-20	11-11	30.2	3.6	115
MS 25043-18-1	MS 18	1 1/8-18	11-11	34.1	3.6	115
MS 25043-20-1	MS 20	1 1/4-18	11-11	37.3	4.4	127
MS 25043-22-1	MS 22	1 3/8-18	11-11	40.4	4.4	127
MS 25043-24-1	MS 24	1 1/2-18	11-11	43.6	4.4	140
MS 25043-28-1	MS 28	1 3/4-18	12-7	50	4.4	197
MS 25043-32-1	MS 32	2 -18	12-7	56.3	4.8	197
MS 25043-36-1	MS 36	2 1/4-18	12-7	62.7	4.8	197
MS 25043-40-1	MS 40	2 1/2-16	12-7	69	4.8	197

- Notes :
1. For protective caps without chain or with nylon cord, contact factory
 2. Standard - black anodised finish. For alternatives, contact factory.
 3. Standard - straight For diamond knurling on caps, contact factory.

Protective cap for 97B series 97B-25042

For Plugs

Has external grooves and is used on all plugs

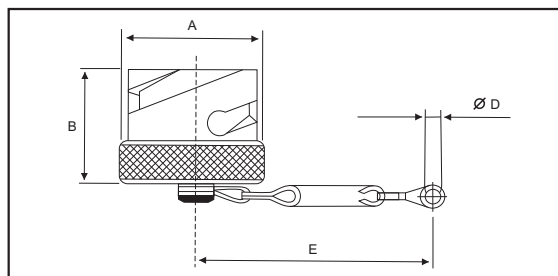

All Dimensions are in mm

Part number	For connector size	A Max	B	D	E
97B 25042-10SL	10SL	23.00	24.00	4.20	102
97B 25042-14S	14S	30.00	24.00	4.20	115
97B 25042-16S	16S	32.50	24.00	4.20	115
97B 25042-16	16	32.50	33.00	4.70	115
97B 25042-18	18	36.40	39.00	4.70	115
97B 25042-20	20	40.50	33.00	4.70	127
97B 25042-22	22	43.50	33.00	4.70	127
97B 25042-24	24	46.50	44.00	4.70	140
97B 25042-28	28	54.00	33.00	5.60	197
97B 25042-32	32	60.00	46.00	5.60	197
97B 25042-36	36	66.20	46.00	5.60	197
97B 25042-40	40	73.00	33.00	5.60	197

Protective cap for 97B series 97B-25043

For receptacles

Has internal bayonet pins and is used on all receptacles.

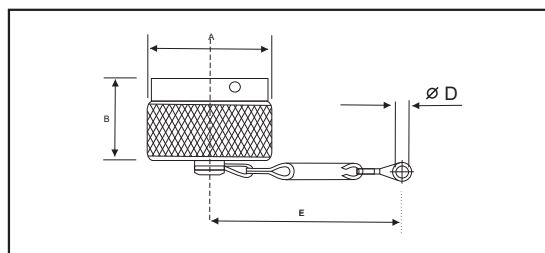

All Dimensions are in mm

Part number	For connector size	A Max	B	D	E
97B 25043-10SL	10SL	23.00	15.50	4.20	102
97B 25043-14S	14S	30.00	15.50	4.20	115
97B 25043-16S	16S	32.50	15.50	4.20	115
97B 25043-16	16	32.50	21.20	4.20	115
97B 25043-18	18	37.00	21.20	4.20	115
97B 25043-20	20	40.50	21.20	4.70	127
97B 25043-22	22	43.50	21.20	4.70	127
97B 25043-24	24	47.50	21.20	4.70	140
97B 25043-28	28	54.00	21.20	5.60	197
97B 25043-32	32	60.50	21.20	5.60	197
97B 25043-36	36	67.00	21.20	5.60	197
97B 25043-40	40	73.00	21.20	5.60	197

- Notes :
1. For protective caps without chain or with nylon cord, contact factory
 2. Standard - black anodised finish. For alternatives, contact factory.
 3. Standard - straight For diamond knurling on caps, contact factory.

PG Adapter

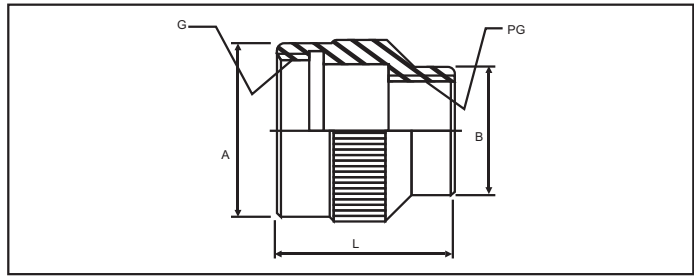

All Dimensions are in mm

Shell Size	G Thread in inches	PG 9			PG 11			PG13			PG16			PG21			PG29			PG36			
		A	B	L	A	B	L	A	B	L	A	B	L	A	B	L	A	B	L	A	B	L	
10SL	5/8-24																						
12S	11/16-24																						
14	3/4-20				23	23	30	23	23	30													
16	7/8-20				25	25	30				25	25	30										
18	1-20	30	21	26	30	26	37				30	28	37										
20	1 1/8-18				35	26	40				35	28	40	35	35	40							
22	1 1/4-18										35	28	40	35	35	40							
24	1 3/8-18													38	35	40	40	40	40				
28	1 5/8-18													45	37	45	45	45	45				
36	2 1/8-18																57	44	55	57	57	55	

Notes : For ordering information on flat gaskets and PG adaptors,contact factory.

Flange Gasket MS-52000

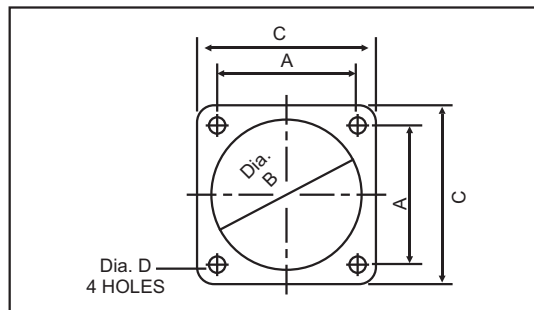

All Dimensions are in mm

Part number	For connector Size	A Max	B	D	E
MS-101000	10SL	18.26	15.90	25.40	4.35
MS-108686	12S & 12	20.62	19.05	27.80	4.35
MS-101001	14S & 14	23.01	22.20	30.15	4.35
MS-101002	16S & 16	24.61	25.40	32.50	4.35
MS-101003	18	27.00	28.57	34.90	5.15
MS-101004	20	29.36	31.75	38.10	5.15
MS-101005	22	31.75	34.90	41.20	5.15
MS-108687	24	34.90	38.10	44.45	5.15
MS-101006	28	39.70	44.45	50.80	5.15
MS-108688	32	44.45	50.80	57.15	5.55
MS-101007	36	49.22	55.57	63.50	5.55

Notes : The dash number also indicates shell size.

Dummy receptacle
MS-3105

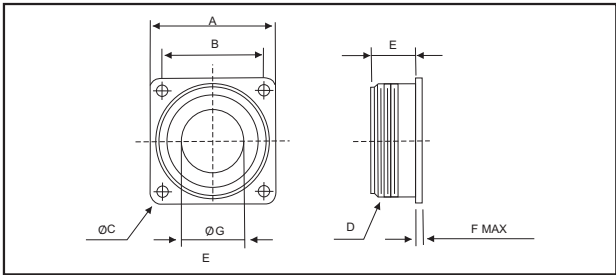

All Dimensions are in mm

Part number (see note)	A	B	C	D Thread in inches	E	F	G
MS-3105-10S	25.4	18.26	3.05	5/8-24	14-27	3.96	8.20
MS-3105-12S	27.79	20.62	3.05	3/4-20	14-27	3.96	11.43
MS-3105-12	27.789	20.62	3.05	3/4-20	19-05	3.96	11.43
MS-3105-14S	30.17	23.01	3.05	7/8-20	14-27	3.96	13.36
MS-3105-14	30.17	23.01	3.05	7/8-20	19.05	3.96	13.36
MS-3105-16S	32.54	24.61	3.05	1-20	14.27	3.96	16.41
MS-3105-16	32.54	24.61	3.05	1-20	19.05	3.96	16.41
MS-3105-18	34.92	26.97	3.05	1 1/8-18	19.05	5.16	18.03
MS-3105-20	38.10	29.36	3.05	1 1/4-18	19.05	5.16	23.54
MS-3105-22	41.27	31.75	3.05	1 3/8-18	19.05	5.16	25.93
MS-3105-24	44.45	34.92	3.73	1 1/2-18	20.62	5.16	29.21
MS-3105-28	50.8	39.67	3.73	1 3/4-18	20.62	5.16	34.67
MS-3105-36	63.5	49.22	4.39	2 1/4-16	22.22	9.11	46.56

Notes : The dash number also indicates shell size.

Strain Relief Backshell Class E and F

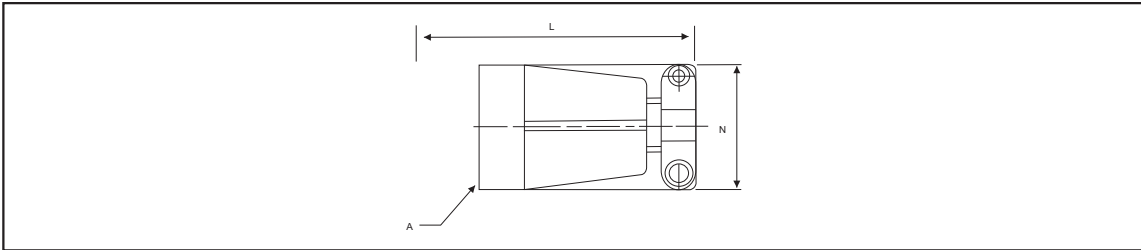

All Dimensions are in mm

Part number	A	A Thread Class 2B in inches	L max for MS/97	L max for 97B	N max
MS-108155	10SL	5/8-24 NEF	54.07	59.10	21.97
MS-108156	12S	11/16-24NEF	54.07	---	21.97
MS-108157	14S	3/4-20 UNEF	55.90	61.34	25.15
MS-108158	16S	7/8-20 UNEF	55.90	62.86	28.45
MS-108158	16	7/8-20UNEF	64.41		28.45
MS-108159	18	1-20 UNEF	65.94	71.10	30.76
MS-108160	20	1 1/8-24 NS	67.41	72.55	37.29
MS-108161	22	1 1/4-18 NEF	67.41	72.55	37.29
MS-108162	24	1 3/8-18NEF	73.28	76.82	44.45
MS-108163	28	1 5/8-18 NEF	73.28	77.82	44.45
MS-108164	32	1 29/32-18 NS	74.75		52.22
MS-108165	36	2 1/16-20 UNS	74.75	77.64	57.15

Standard finish is cadmium Olive drab

Right Angle Backshell

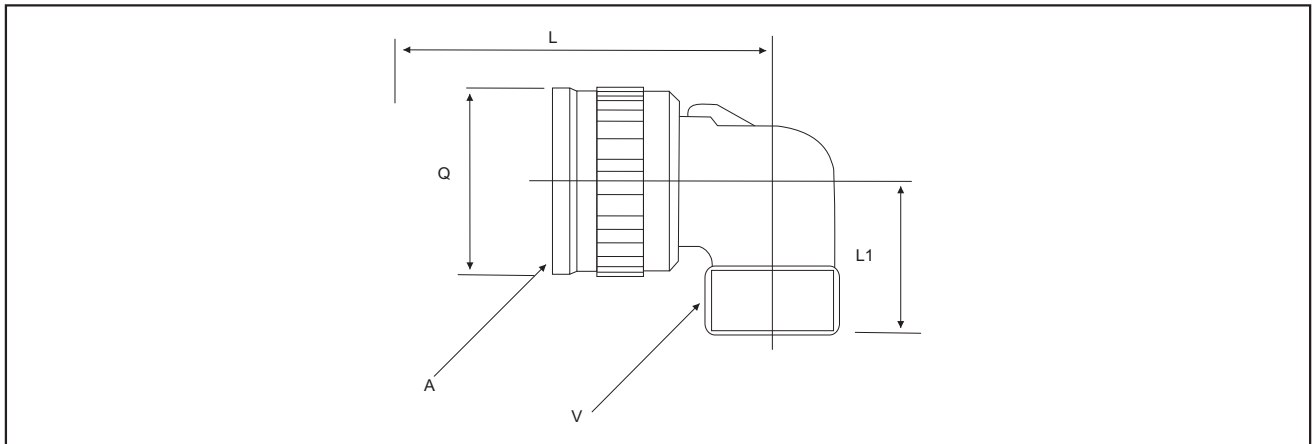

All Dimensions are in mm

Part number	Connector Size	A Thread Class 2B in inches	L max for MS/97	L max for 97B	L 1 max	L 1 max	V Thread in inches
MS-108917	10SL	5/8-24 NEF	37.60	45.00	25.00	22.22	5/8-24 UNEF
MS-108918	12S	11/16-24 NEF	37.80	---	25.00	25.40	5/8-24 UNEF
MS-108918	12	11/16-24 NEF	47.30	---	25.00	25.40	5/8-24 UNEF
MS-108919	14S	3/4-20NEF	39.40	47.00	27.00	28.57	3/4-20UNEF
MS-108919	14	3/4-20 UNEF	48.90	---	27.00	28.57	3/4-20 UNEF
MS-108920	16S	7/8-20 UNEF	42.60	48.00	28.00	31.75	7/8-20 UNEF
MS-108920	16	7/8-20UNEF	52.10	57.00	28.00	31.75	7/8-20UNEF
MS-108921	18	1-20 UNEF	53.70	58.00	31.00	34.13	1-20 UNEF
MS-108922	20	1 1/8-24 NS	58.80	61.00	34.00	37.30	1 3/16-18 NS
MS-108923	22	1 1/4-18 NEF	58.80	61.00	34.00	40.48	1 3/16-18 UNEF
MS-108924	24	1 3/8-18NEF	63.60	66.00	37.00	43.66	1 7/16-18 UNEF
MS-108925	28	1 5/8-18 NEF	63.60	66.00	39.00	50.00	1 7/16-18 UNEF
MS-108926	32	1 29/32-18 NS	69.60	72.00	45.00	56.50	1 3/4-18 UNS
MS-108927	36	2 1/16-20 UNS	72.80	75.00	48.00	62.71	2-18 UNS

Standard finish is cadmium Olive drab

Note : Both versions, straight and diamond knurling available on back accessories. For details, contact factory.

SERIES MS347 & MS CRIMP

These are the accessories compatible with connectors according to MIL-C-26482 Series 2 & MIL-C-5015 Crimp type. The standard finishes of these accessories are Cadmium with olive drab chromate. Other alternate finishes are also available on request.

M85049/26-1 Straight Shield Termination

M85049/26-2 Shielding Ring

M85049/31 Straight Back Shell

M85049/34 Straight Adapter

M85049/52-1 Straight SR Clamp

M85049/60-1 Shrink Boot Adapter

Straight Shield Termination M85049/26-1

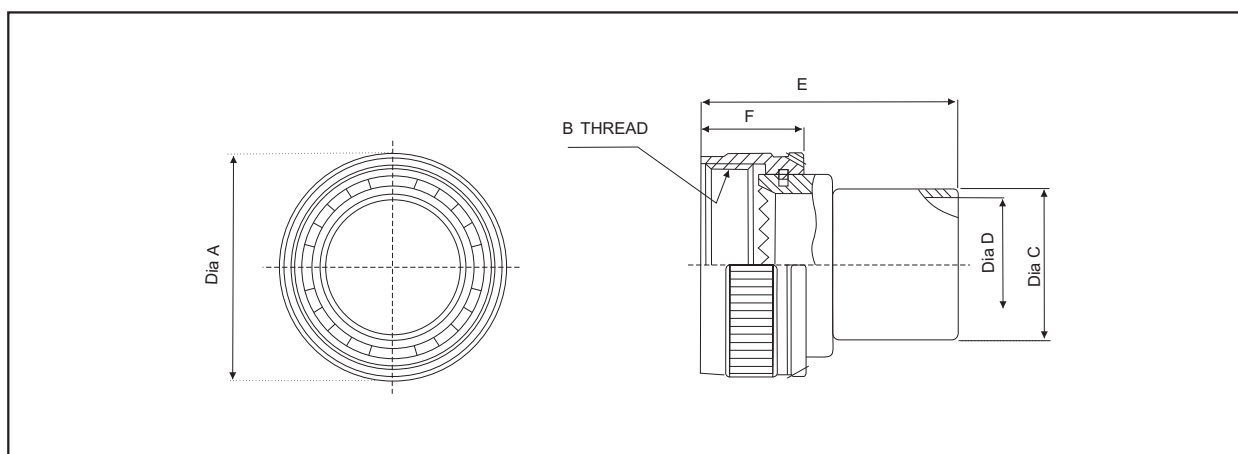
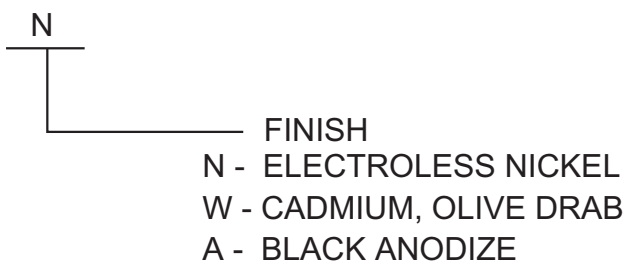
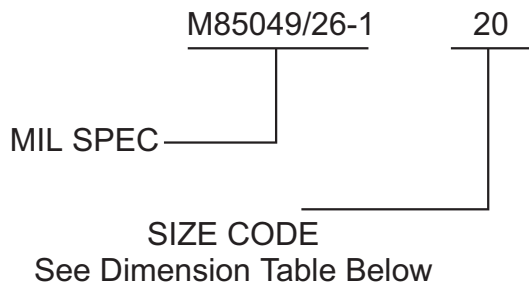

Size Code	MIL-C-26482 Series 2	MIL-C-5015 Crimp	A dia	B Thread Class 28	C dia	D dia	E	F
8	8	85	15.68	1/2-20UNE	8.56	6.35	32.44	13.72
10	10	10S,10SL	18.65	5/8-24UNEF	12.40	8.26	32.44	13.72
12	12	12S & 12	21.80	3/4-20UNEF	12.70	10.67	32.44	13.72
14	14	14S & 14	25.00	7/8-20UNEF	15.75	13.72	32.44	13.72
16	16	16S & 16	28.25	1-20UNEF	19.05	17.02	32.44	13.72
18	18	18	30.94	1-1/16-18UNEF	22.36	20.05	32.44	13.72
20	20	20	34.17	1-3/16-18UNEF	25.44	23.22	32.44	13.72
22	22	22	37.29	1-5/16-18UNEF	28.45	26.40	32.44	13.72
24	24	24	40.47	1-7/16-18UNEF	30.28	28.25	32.44	13.72
28		28	50.10	1-3/4-18UNS	39.25	35.29	36.66	17.84
32		32	56.37	2-18UNS	45.60	41.53	36.66	17.84
36		36	62.72	2.1/46UN	51.95	47.00	36.66	17.84

Shielding Ring
M85049/26-2

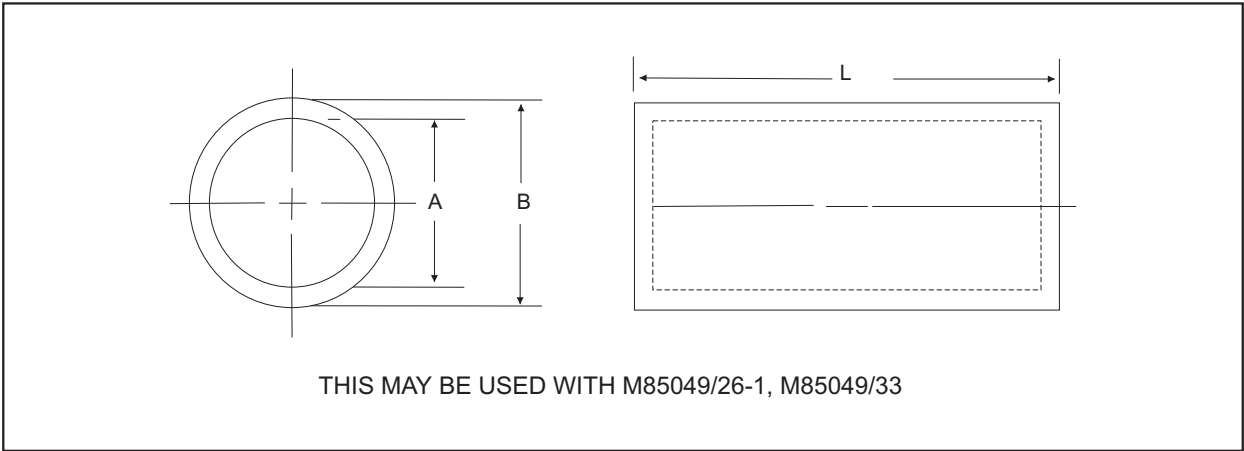
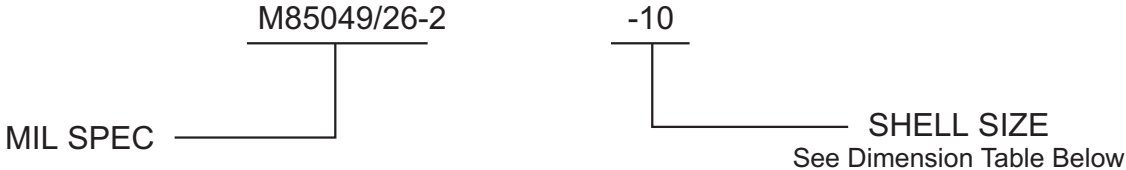

Size Code	Colour Code	A dia		B dia		L -0.20
		min	Max	Min	Max	
8	GREEN	10.16	10.42	12.40	11.64	6.35
10	RED	14.86	15.12	16.77	17.28	
12						
14	BLUE	17.91	18.17	19.82	20.32	
16	GRAY	21.21	21.47	23.12	23.63	
18	BROWN	25.53	25.79	27.44	27.94	
20	GREEN	28.58	28.83	30.48	30.99	
22	PINK	31.63	31.88	33.53	34.04	
24						
28	RED	42.30	42.55	44.20	44.71	
32	GRAY	48.65	48.90	50.55	51.05	
36	GREEN	55.00	55.25	56.90	57.41	

STANDARD MATERIAL IS COPPER AND FINISH TIN PLATING CONSULT FACTORY FOR ANY VARIATIONS

Straight Back Shell M85049/31

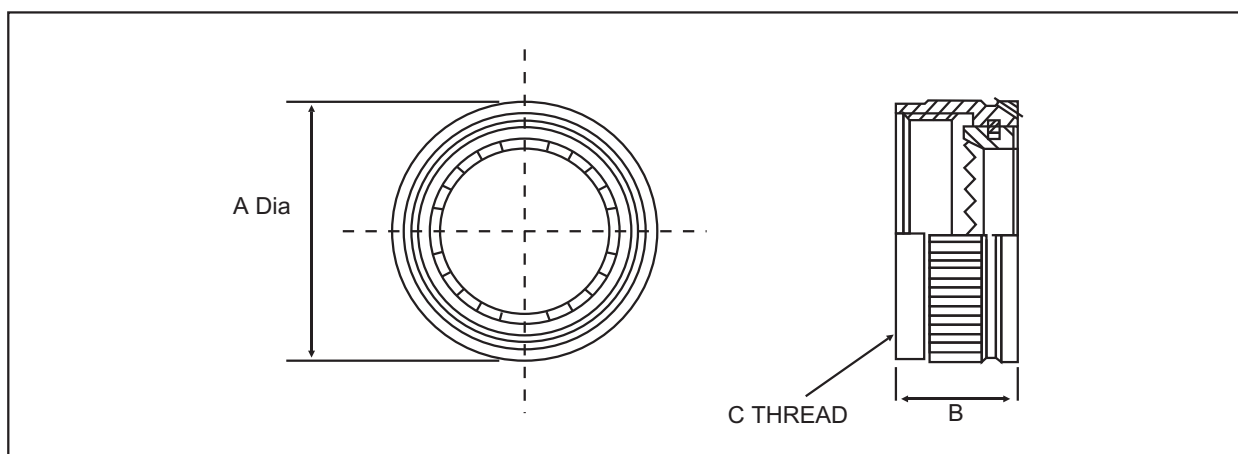
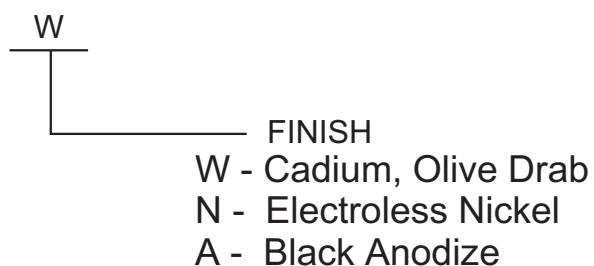
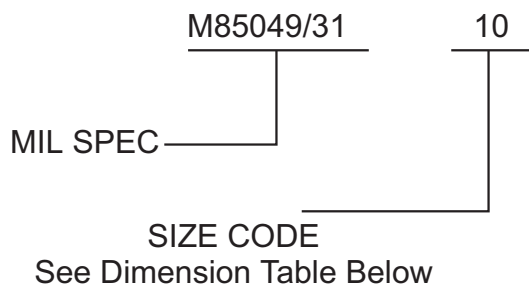

Size Code	Connector Shell Size		A	B	C Thread Class 2B
	MIL-C-26482 Series 2	MIL-C-5015 Series 2			
8	8	8S	15.67	13.72	1/2-20 UNF
10	10	10S, 10SL	18.64	13.72	5/8-24 UNEF
12	12	12S & 12	21.79	13.72	3/4-20 UNEF
14	14	14S & 14	24.99	13.72	7/8-20 UNEF
16	16	16S & 16	28.24	13.72	1-20 UNEF
18	18	18	30.94	13.72	1-1/16-18 UNEF
20	20	20	34.16	13.72	1-3/16-18 UNEF
22	22	22	37.29	13.72	1-5/16-18 UNEF
24	24	24	40.46	13.72	1-7/16-18 UNEF
28		28	50.01	17.83	1-3/4-18 UNS
32		32	56.36	17.83	2-18 UNS
36		36	62.71	17.83	2-1/4-16 UN

Straight Adapter
 For MS3114, MS3124 & MS 3474 Receptacles

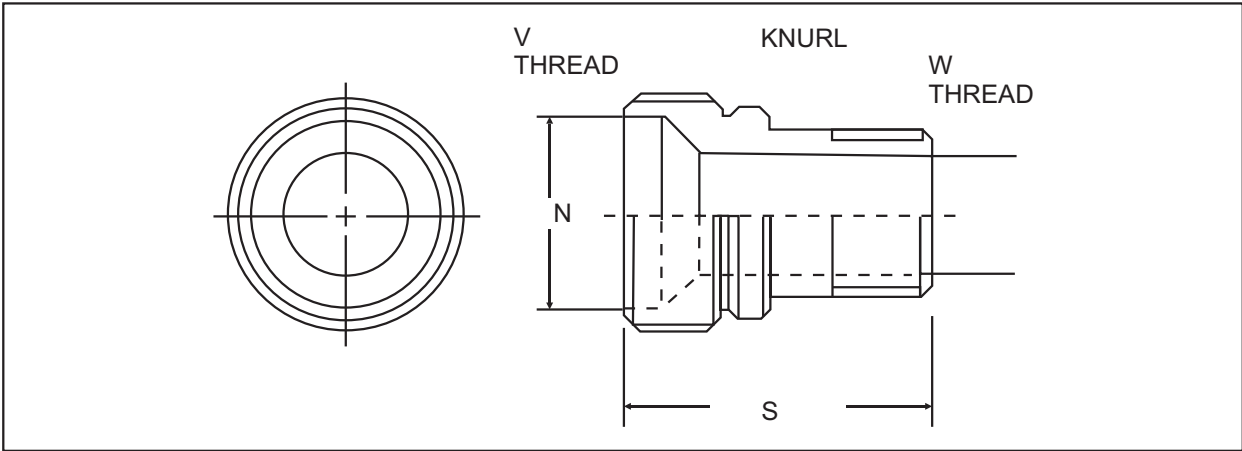
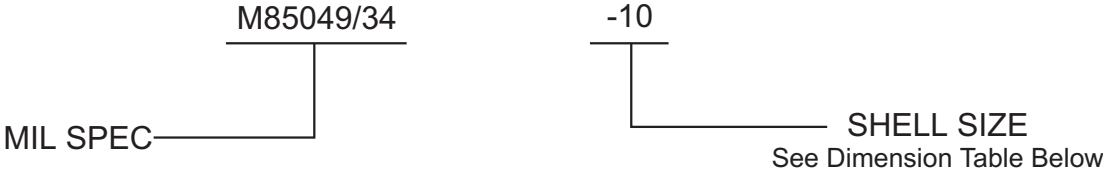

Size Code	F dia + 0.13 -0.02	N dia + 0.25 - 0.27	S max	Thread UNEF Class2 A	
				V	W
8	8.18	12.7	20.63	5/8-24	7/16-28
10	11.16	15.47	20.63	3/4-20	9/16-24
12	14.33	18.65	20.63	7/8-20	13/16-24
14	16.97	21.82	20.63	1-20	13/16-20
16	20.15	24.62	20.63	1-1/8-18	15/16-20
18	23.12	28.16	20.63	1-1/4-18	1-1/16-18
20	26.04	30.97	23.02	1-3/8-18	1-3/16-18
22	29.22	34.14	23.02	1-1/2-18	1-5/16-18
24	32.39	37.32	23.79	1-5/8-18	1-7/16-18

STANDARD FINISH IS CADMIUM OLIVE DRAB FOR OTHER FINISHES CONSULT FACTORY

Straight Strain Relief M85049/52-1

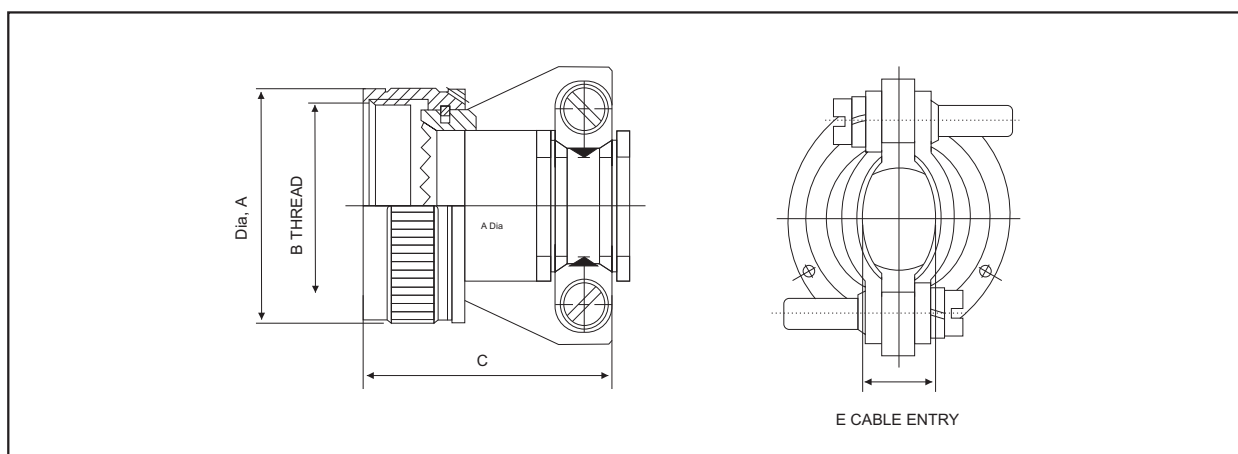
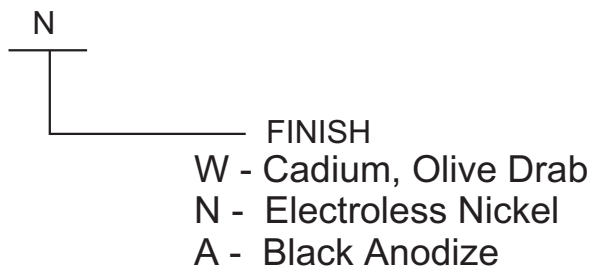
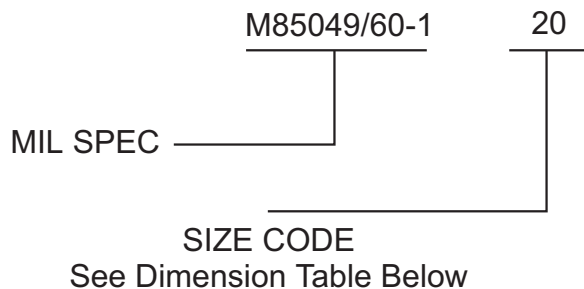

Size Code	For Connector Shell Size (REF)		A max	B Thread Class 2 B	C	E Cable Entry	
	MIL-C-26482 Series	MIL-C-5015 Crimp				Max	Min
8	8	8 S	15.67	1/2-20 UNF	22.61	5.18	3.17
10	10	10S, 10SL	18.64	5/8-24 UNEF	25.40	7.26	4.74
12	12	12S & 12	21.79	3/4-20 UNEF	28.57	10.56	7.39
14	14	14S & 14	24.99	7/8-20 UNEF	28.57	12.09	8.91
16	16	16S & 16	28.24	1-20UNEF	31.75	15.90	12.72
18	18	18	30.93	1-1/16 -18UNEF	38.10	17.93	13.15
20	20	20	34.16	1-3/16 -18UNEF	41.27	21.10	14.75
22	22	22	37.29	1-5/16 -18UNEF	44.45	24.28	16.35
24	24	24	40.46	1-7/16 -18UNEF	47.62	27.47	17.93
28		28	50.01	1-3/4 -18UNS	55.54	30.10	19.05
32		32	56.36	2 -18UNS	60.32	31.75	22.22
36		36	62.71	2-1/4 -16UNS	69.85	34.92	23.82

Shrink Boot Adapter
 For MS3114, MS3124 & MS3474 Receptacles

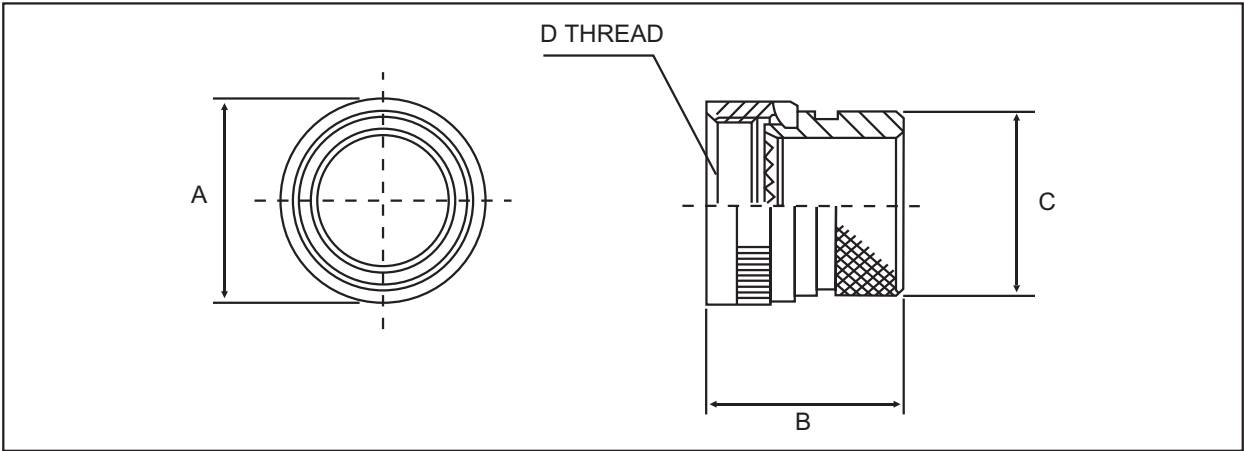
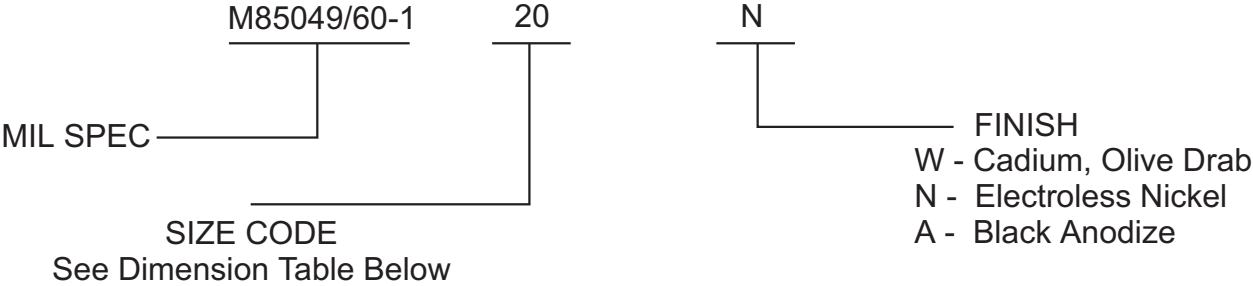

Size Code	Connector Shell Size		A Dia	B	C Dia	D Thread Class2 B
	MIL-C-26482 Series 2 M83723 SR I & III	MIL-C-5015 Crimp				
-8	8	8 S	15.67	28.57	13.53	1/2-20UNF
-10	10	10S, 10SL	18.64	28.57	15.36	5/8-24 UNEF
-12	12	12S & 12	21.79	28.57	19.65	3/4-20 UNEF
-14	14	14S & 14	24.99	28.57	21.28	7/8-20 UNEF
-16	16	16S & 16	28.24	28.57	24.46	1-20 UNEF
-18	18	18	30.93	28.57	26.46	1-1/16-18 UNEF
-20	20	20	34.16	28.57	30.91	1-3/16-18 UNEF
-22	22	22	34-28	28.57	34.41	1-5/16-18 UNEF
-24	24	24	40.46	28.57	36.65	1-7/16-18 UNEF
-28		28	50.01	32.68	43.40	1-3/4-18 UNEF
-32		32	56.36	36.80	48.74	2-18 UNEF
-36		36	62.7	36.80	55.09	2 1/4-16 UNEF

STANDARD FINISH IS CADMIUM OLIVE DRAB FOR OTHER FINISHES CONSULT FACTORY

SERIES - D38999

These are the accessories compatible with connectors according to MIL-C-38999 Series 3. The standard finishes of these accessories are Cadmium with olive drab chromate. Other alternate finishes are also available on request.

M85049/14	Back Shell
M85049/33-2	Straight Shield Termination
M85049/35	Straight Adapter
M85049/38	Straight Strain Relief
M85049/58	Plotting Boot Ring
M85049/69	Shrink Boot Adapter

Back Shell
M85049/14

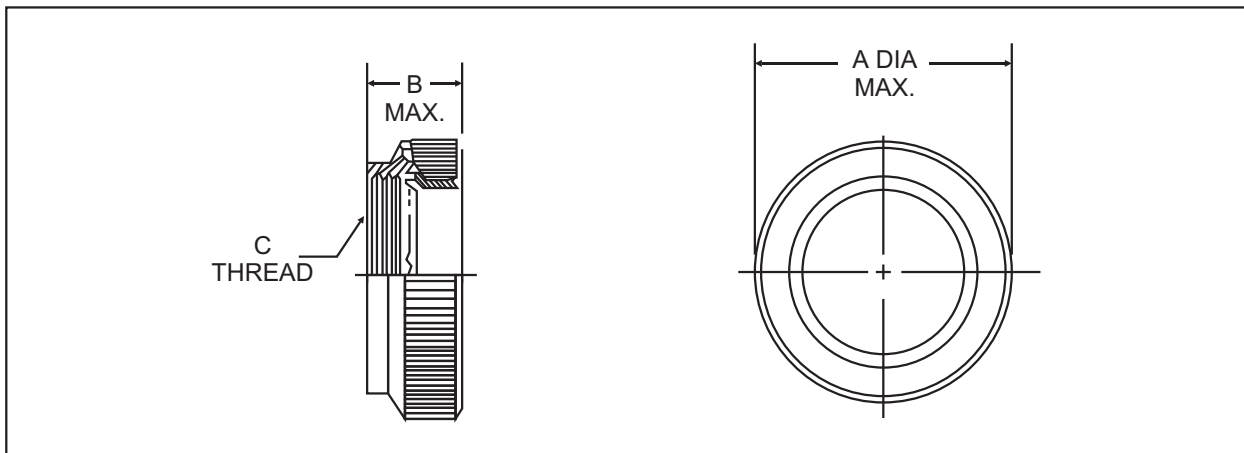
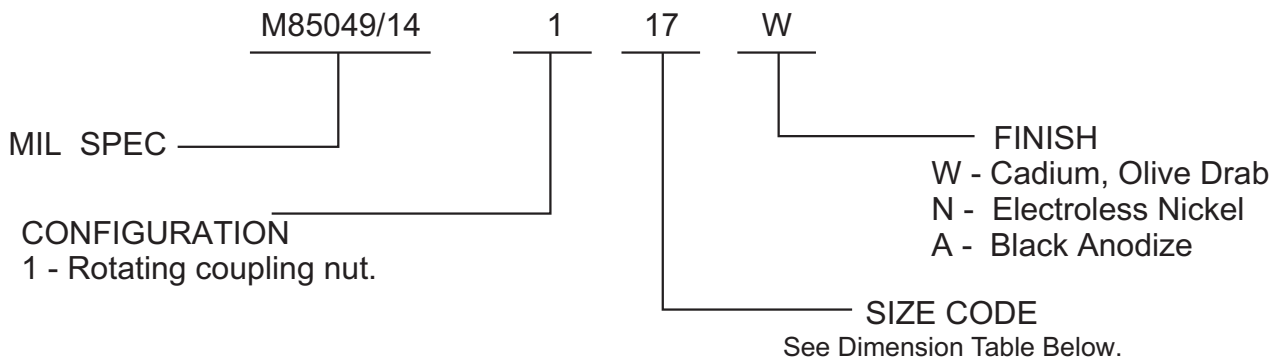

Size Code	M85049 Self Locking Only		C Thread Metric RH Class 6H
	A max	B max	
9	21.79	16.76	M12 x 1.0-0.10R
11	24.99	16.76	M15 x 1.0-0.10R
13	29.38	16.76	M18 x 1.0-0.10R
15	32.48	16.76	M22 x 1.0-0.10R
17	35.71	16.76	M25 x 1.0-0.10R
19	38.50	16.76	M28 x 1.0-0.10R
21	41.70	16.76	M31 x 1.0-0.10R
23	44.90	16.76	M34 x 1.0-0.10R
25	47.98	16.76	M37 x 1.0-0.10R

Straight Shield Termination M85049/33

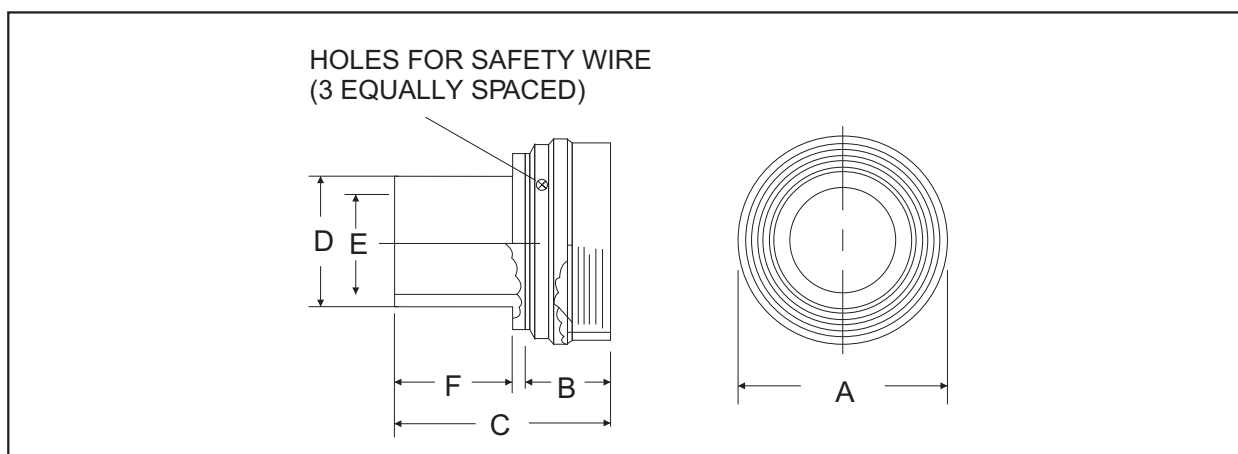
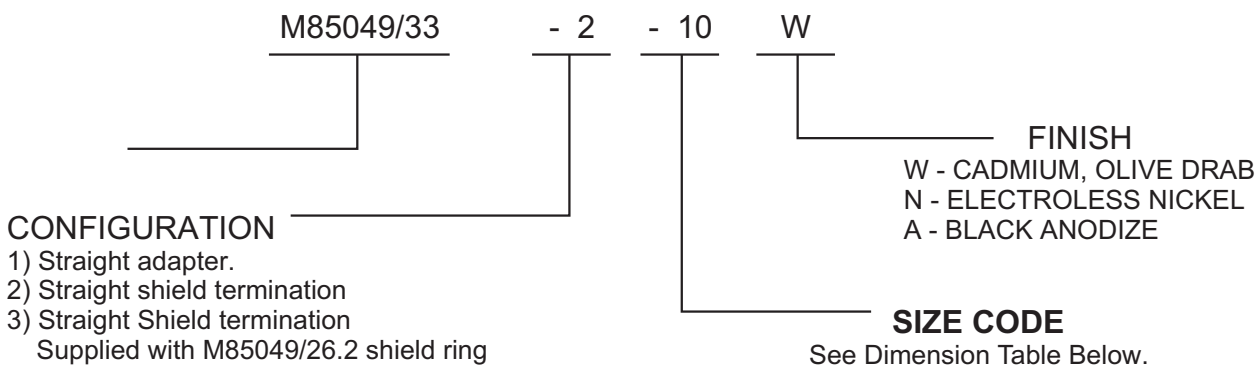

Size Code	MIL-C-3899 Shell Size		A dia max	B max	C max	D dia max	F min	USE M85049/26-2 Crimp Ring
	Series I	Series II						
8	9	8	19.05	13.72	28.88	8.82	6.74	8
10	11	10	21.59	13.72	28.88	12.65	8.72	10
12	13	12	25.40	13.72	28.88	12.83	11.10	12
14	15	14	27.94	13.72	28.88	16.00	14.28	14
16	17	16	31.75	13.72	28.88	19.31	17.45	16
18	19	18	35.56	13.72	28.88	22.61	20.63	18
20	21	20	38.10	13.72	28.88	25.66	23.80	20
22	23	22	41.91	13.72	28.88	28.71	26.57	12
24	25	24	43.18	13.72	28.88	30.54	28.58	24

**Straight Adapter
M 85049/35**

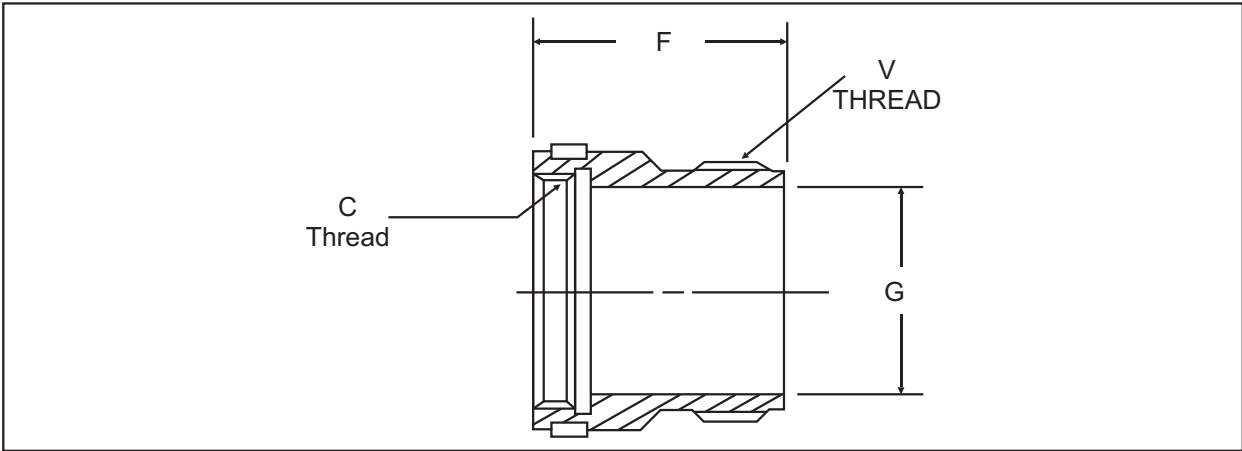
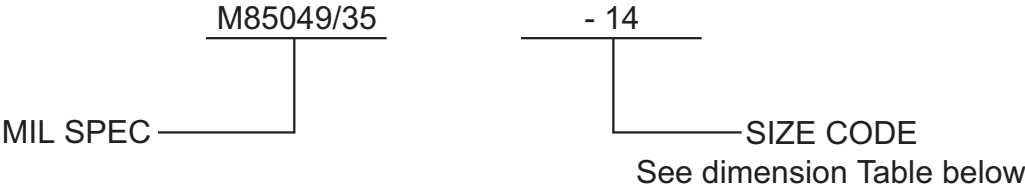

Size code	MIL-C-38999 Shell Size		C Thread Class 2B UNEF	F max	G min dia	V Thread Class 2A UNEF
	Series 11	Series 1				
8	8	9	7/16-28	17.48	7.14	1/2-28
10	10	11	9/16-24		10.32	5/8-24
12	12	13	11/16-20		13.49	3/4-20
14	14	15	13/16-20		16.67	7/8-20
16	16	17	15/16-20		19.83	1-20
18	18	19	1 1/16-18		19.05	22,23
20	20	21	1 3/16-18	25.40		
22	22	23	1 5/16-18	28.58		1 7/16-18
24	24	25	1 7/16-18	31.57		

Straight Strain Relief M 85049/38

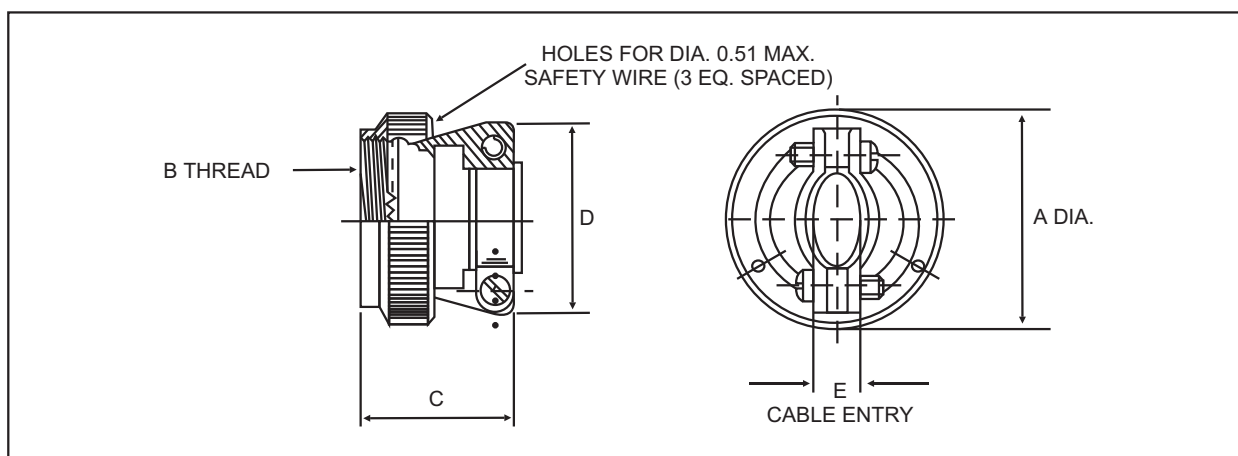
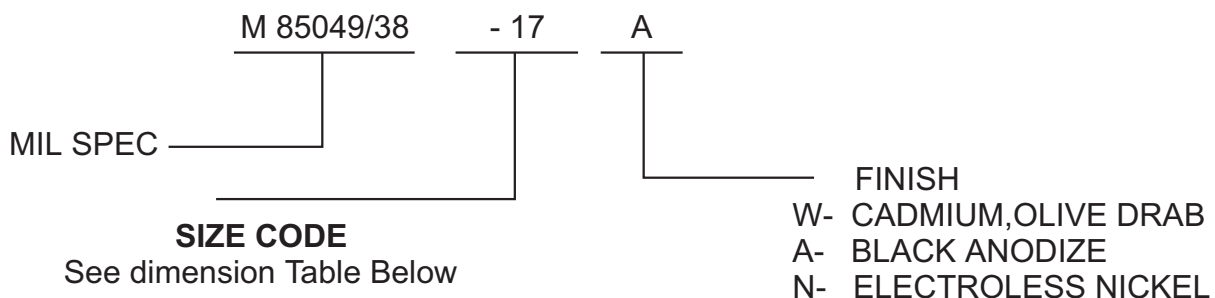

Shell Size	A max	B Metric R. H. Thread Class 6H	C max	D max	E Cable Clamp	
					max	min
9	21.79	M12-1.0-0.100R	27.9	21.6	5.94	2.49
11	24.99	M15-1.0-0.100R	27.9	22.9	5.94	3.89
13	29.39	M18-1.0-0.100R	30.5	27.9	8.83	4.83
15	32.49	M22-1.0-0.100R	31.8	29.2	11.61	6.60
17	35.71	M25-1.0-0.100R	34.3	33.0	16.10	7.19
19	38.50	M28-1.0-0.100R	40.6	38.1	15.60	8.26
21	41.70	M31-1.0-0.100R	43.2	40.6	17.73	8.71
23	44.91	M34-1.0-0.100R	47.0	43.2	20.90	9.68
25	47.98	M37-1.0-0.100R	49.5	45.7	21.67	10.62

**Potting Boot Ring
M85049/58**

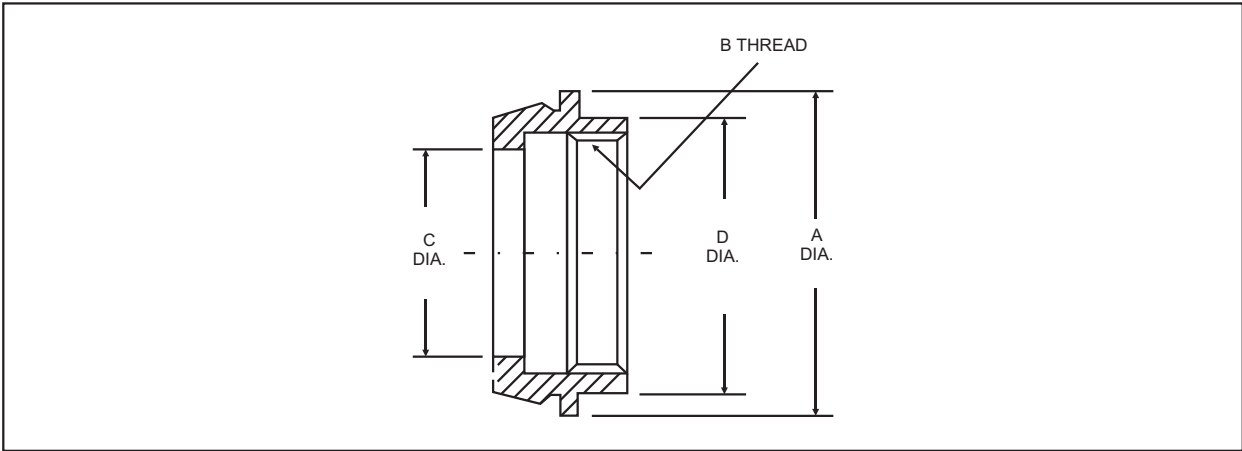
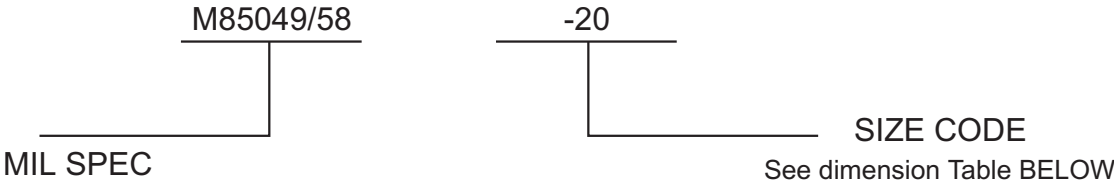

Size Code	MIL - C-38999 Shell Size		A max dia	B Thread UNEF Class 2B	C +.005 dia	D +.005 dia
	Series I	Series II				
8	9	8	15.24	7/16-28	8.74	12.70
10	11	10	18.54	9/16-24	11.99	15.88
12	13	12	21.59	11/16-24	14.89	19.05
14	15	14	24.80	13/16-20	18.06	22.23
16	17	16	28.00	15/16-20	21.24	25.40
18	19	18	31.15	1-1/16-18	23.93	28.58
20	21	20	34.35	1-3/16-18	27.11	31.75
22	23	22	37.50	1-5/16-18	30.28	34.93
24	25	24	40.70	1-7/16-18	33.46	38.10

STANDARD FINISH IS CADMIUM OLIVE DRAB FOR OTHER FINISHES CONSULT FACTORY

Shrink Boot Adapter M85049/69

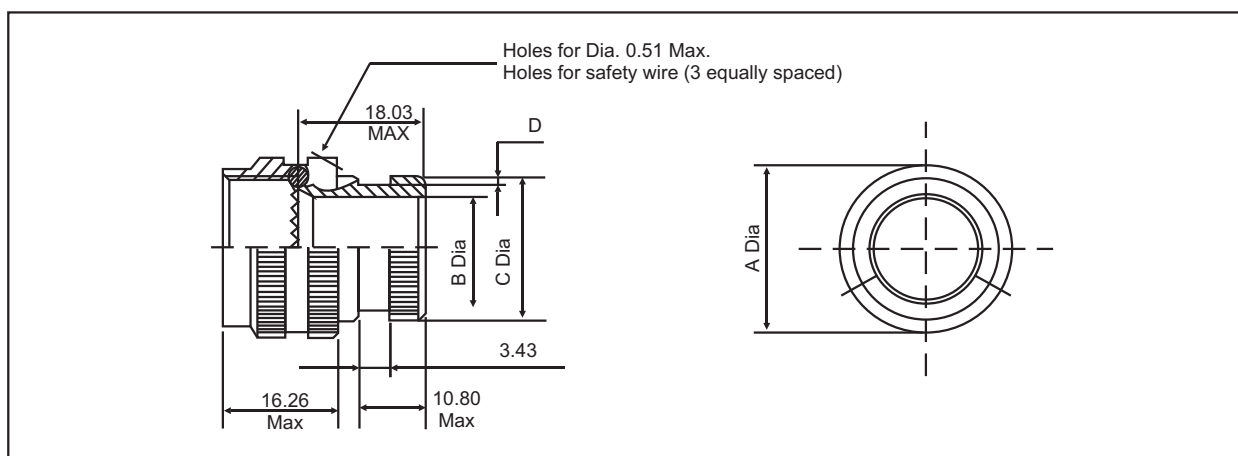
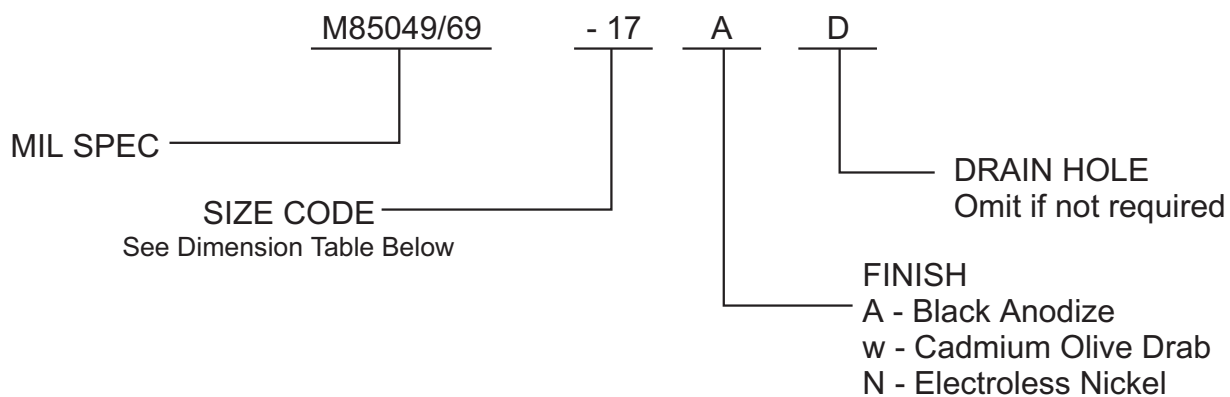

Size Code	A Dia max	B max	C dia max	D +.00 -0.20
9	19.1	6.35	13.54	1.12
11	21.6	9.52	15.37	1.12
13	25.4	12.70	19.66	1.12
15	29.20	15.88	21.29	1.12
17	31.8	19.05	24.46	1.12
19	35.6	20.62	26.47	1.12
21	39.40	23.80	30.91	1.75
23	41.9	26.97	34.42	1.75
25	47.00	30.18	36.65	1.75

SERIES 164

These are accessories compatible with connectors to MIL-C-55116. The standard finishes of these accessories are Cadmium with olive drab chromate. Other alternate finishes are also available on request.

164-895	Cap for receptacles
164-896	Cap for plug
164-377	Cap for 10 pin Receptacle

Accessories

Cap and chain

These cap and chain assemblies are used with 5 and 6 pin connectors as protective covers giving additional protection against moisture, dust and sand. The caps are manufactured from aluminum and black anodized. The chain is manufactured from stainless steel and is passivated.

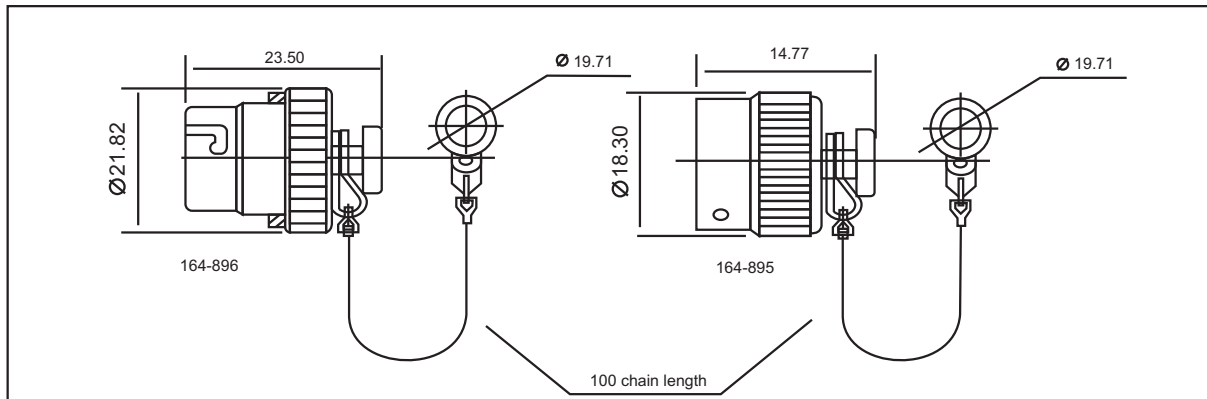

All Dimensions are in mm

Part Number	For Connector
164-895	164-183
164-896	164-229

Cap and chain for ten pin waterproof audio receptacles (U-79 / U) Part No. 164-377

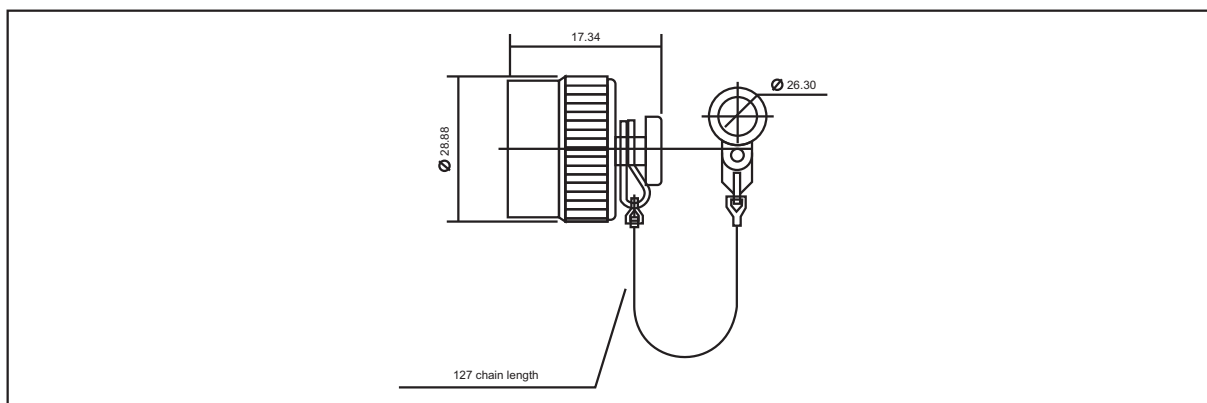

Special accessories

Please contact factory with specifications and drawings. Amphenol has in-house capability to meet and custom build your special accessories requirements for circular connectors.

Notice :

All information, including illustrations given herein is believed to be accurate at the time printing. In Lieu of design advances. Amphenol reserves the right to change specifications without notice. This publication ACR 91/00-01 supersedes all existing Amphenol literature on backshells & accessories for circular connectors.

Компания «Океан Электроники» предлагает заключение долгосрочных отношений при поставках импортных электронных компонентов на взаимовыгодных условиях!

Наши преимущества:

- Поставка оригинальных импортных электронных компонентов напрямую с производств Америки, Европы и Азии, а так же с крупнейших складов мира;
- Широкая линейка поставок активных и пассивных импортных электронных компонентов (более 30 млн. наименований);
- Поставка сложных, дефицитных, либо снятых с производства позиций;
- Оперативные сроки поставки под заказ (от 5 рабочих дней);
- Экспресс доставка в любую точку России;
- Помощь Конструкторского Отдела и консультации квалифицированных инженеров;
- Техническая поддержка проекта, помощь в подборе аналогов, поставка прототипов;
- Поставка электронных компонентов под контролем ВП;
- Система менеджмента качества сертифицирована по Международному стандарту ISO 9001;
- При необходимости вся продукция военного и аэрокосмического назначения проходит испытания и сертификацию в лаборатории (по согласованию с заказчиком);
- Поставка специализированных компонентов военного и аэрокосмического уровня качества (Xilinx, Altera, Analog Devices, Intersil, Interpoint, Microsemi, Actel, Aeroflex, Peregrine, VPT, Syfer, Eurofarad, Texas Instruments, MS Kennedy, Miteq, Cobham, E2V, MA-COM, Hittite, Mini-Circuits, General Dynamics и др.);

Компания «Океан Электроники» является официальным дистрибьютором и эксклюзивным представителем в России одного из крупнейших производителей разъемов военного и аэрокосмического назначения «JONHON», а так же официальным дистрибьютором и эксклюзивным представителем в России производителя высокотехнологичных и надежных решений для передачи СВЧ сигналов «FORSTAR».



JONHON

«JONHON» (основан в 1970 г.)

Разъемы специального, военного и аэрокосмического назначения:

(Применяются в военной, авиационной, аэрокосмической, морской, железнодорожной, горно- и нефтедобывающей отраслях промышленности)

«FORSTAR» (основан в 1998 г.)

ВЧ соединители, коаксиальные кабели,
кабельные сборки и микроволновые компоненты:

(Применяются в телекоммуникациях гражданского и специального назначения, в средствах связи, РЛС, а так же военной, авиационной и аэрокосмической отраслях промышленности).



Телефон: 8 (812) 309-75-97 (многоканальный)

Факс: 8 (812) 320-03-32

Электронная почта: ocean@oceanchips.ru

Web: <http://oceanchips.ru/>

Адрес: 198099, г. Санкт-Петербург, ул. Калинина, д. 2, корп. 4, лит. А