

36 Mb (1M x 36 & 2M x 18) QUAD (Burst of 2) Synchronous SRAMs



JANUARY 2010

Features

- 1M x 36 or 2M x 18.
- On-chip delay-locked loop (DLL) for wide data valid window.
- Separate read and write ports with concurrent read and write operations.
- Synchronous pipeline read with early write operation.
- Double data rate (DDR) interface for read and write input ports.
- Fixed 2-bit burst for read and write operations.
- Clock stop support.
- Two input clocks (K and \bar{K}) for address and control registering at rising edges only.
- Two input clocks (C and \bar{C}) for data output control.
- Two echo clocks (CQ and \bar{CQ}) that are delivered simultaneously with data.
- +1.8V core power supply and 1.5, 1.8V V_{DDQ} , used with 0.75, 0.9V V_{REF}
- HSTL input and output levels.
- Registered addresses, write and read controls, byte writes, data in, and data outputs.
- Full data coherency.
- Boundary scan using limited set of JTAG 1149.1 functions.
- Byte write capability.
- Fine ball grid array (FBGA) package
 - 15mm x 17mm body size
 - 1mm pitch
 - 165-ball (11 x 15) array
- Programmable impedance output drivers via 5x user-supplied precision resistor.

Description

The 36Mb IS61QDB21Mx36 and IS61QDB22Mx18 are synchronous, high-performance CMOS static random access memory (SRAM) devices. These SRAMs have separate I/Os, eliminating the need for high-speed bus turnaround. The rising edge of K clock initiates the read/write operation, and all internal operations are self-timed. Refer to the *Timing Reference Diagram for Truth Table* on page 8 for a description of the basic operations of these SRAMs.

The input address bus operates at double data rate. The following are registered internally on the rising edge of the K clock:

- Read address
- Read enable
- Write enable
- Byte writes
- Data-in for early writes

The following are registered on the rising edge of the \bar{K} clock:

- Write address
- Byte writes
- Data-in for second burst addresses

Byte writes can change with the corresponding data-in to enable or disable writes on a per-byte basis. An internal write buffer enables the data-ins to be registered half a cycle earlier than the write address. The first data-in burst is clocked at the same time as the write command signal, and the second burst is timed to the following rising edge of the \bar{K} clock.

During the burst read operation, the data-outs from the first burst are updated from output registers off the second rising edge of the \bar{C} clock (1.5 cycles later). The data-outs from the second burst are updated with the third rising edge of the C clock. The K and \bar{K} clocks are used to time the data-outs whenever the C and \bar{C} clocks are tied high.

The device is operated with a single +1.8V power supply and is compatible with HSTL I/O interfaces.

36 Mb (1M x 36 & 2M x 18) QUAD (Burst of 2) Synchronous SRAMs



x36 FBGA Pinout (Top View)

	1	2	3	4	5	6	7	8	9	10	11
A	$\overline{\text{CQ}}$	V _{SS} /SA	NC/SA*	$\overline{\text{W}}$	$\overline{\text{BW}}_2$	$\overline{\text{K}}$	$\overline{\text{BW}}_1$	$\overline{\text{R}}$	SA	V _{SS} /SA	CQ
B	Q27	Q18	D18	SA	$\overline{\text{BW}}_3$	K	$\overline{\text{BW}}_0$	SA	D17	Q17	Q8
C	D27	Q28	D19	V _{SS}	SA	SA	SA	V _{SS}	D16	Q7	D8
D	D28	D20	Q19	V _{SS}	V _{SS}	V _{SS}	V _{SS}	V _{SS}	Q16	D15	D7
E	Q29	D29	Q20	V _{DDQ}	V _{SS}	V _{SS}	V _{SS}	V _{DDQ}	Q15	D6	Q6
F	Q30	Q21	D21	V _{DDQ}	V _{DD}	V _{SS}	V _{DD}	V _{DDQ}	D14	Q14	Q5
G	D30	D22	Q22	V _{DDQ}	V _{DD}	V _{SS}	V _{DD}	V _{DDQ}	Q13	D13	D5
H	$\overline{\text{Doff}}$	V _{REF}	V _{DDQ}	V _{DDQ}	V _{DD}	V _{SS}	V _{DD}	V _{DDQ}	V _{DDQ}	V _{REF}	ZQ
J	D31	Q31	D23	V _{DDQ}	V _{DD}	V _{SS}	V _{DD}	V _{DDQ}	D12	Q4	D4
K	Q32	D32	Q23	V _{DDQ}	V _{DD}	V _{SS}	V _{DD}	V _{DDQ}	Q12	D3	Q3
L	Q33	Q24	D24	V _{DDQ}	V _{SS}	V _{SS}	V _{SS}	V _{DDQ}	D11	Q11	Q2
M	D33	Q34	D25	V _{SS}	V _{SS}	V _{SS}	V _{SS}	V _{SS}	D10	Q1	D2
N	D34	D26	Q25	V _{SS}	SA	SA	SA	V _{SS}	Q10	D9	D1
P	Q35	D35	Q26	SA	SA	C	SA	SA	Q9	D0	Q0
R	TDO	TCK	SA	SA	SA	$\overline{\text{C}}$	SA	SA	SA	TMS	TDI

Note: The following pins are reserved for higher densities: A3 for 64Mb, 10A for 144Mb, and 2A for 288Mb.

x18 FBGA Pinout (Top View)

	1	2	3	4	5	6	7	8	9	10	11
A	$\overline{\text{CQ}}$	V _{SS} /SA*	SA	$\overline{\text{W}}$	$\overline{\text{BW}}_1$	$\overline{\text{K}}$	NC	$\overline{\text{R}}$	SA	V _{SS} /SA*	CQ
B	NC	Q9	D9	SA	NC	K	$\overline{\text{BW}}_0$	SA	NC	NC	Q8
C	NC	NC	D10	V _{SS}	SA	SA	SA	V _{SS}	NC	Q7	D8
D	NC	D11	Q10	V _{SS}	V _{SS}	V _{SS}	V _{SS}	V _{SS}	NC	NC	D7
E	NC	NC	Q11	V _{DDQ}	V _{SS}	V _{SS}	V _{SS}	V _{DDQ}	NC	D6	Q6
F	NC	Q12	D12	V _{DDQ}	V _{DD}	V _{SS}	V _{DD}	V _{DDQ}	NC	NC	Q5
G	NC	D13	Q13	V _{DDQ}	V _{DD}	V _{SS}	V _{DD}	V _{DDQ}	NC	NC	D5
H	$\overline{\text{Doff}}$	V _{REF}	V _{DDQ}	V _{DDQ}	V _{DD}	V _{SS}	V _{DD}	V _{DDQ}	V _{DDQ}	V _{REF}	ZQ
J	NC	NC	D14	V _{DDQ}	V _{DD}	V _{SS}	V _{DD}	V _{DDQ}	NC	Q4	D4
K	NC	NC	Q14	V _{DDQ}	V _{DD}	V _{SS}	V _{DD}	V _{DDQ}	NC	D3	Q3
L	NC	Q15	D15	V _{DDQ}	V _{SS}	V _{SS}	V _{SS}	V _{DDQ}	NC	NC	Q2
M	NC	NC	D16	V _{SS}	V _{SS}	V _{SS}	V _{SS}	V _{SS}	NC	Q1	D2
N	NC	D17	Q16	V _{SS}	SA	SA	SA	V _{SS}	NC	NC	D1
P	NC	NC	Q17	SA	SA	C	SA	SA	NC	D0	Q0
R	TDO	TCK	SA	SA	SA	$\overline{\text{C}}$	SA	SA	SA	TMS	TDI

Note: The following pins are reserved for higher densities: 10A for 72Mb and 2A for 144Mb.

36 Mb (1M x 36 & 2M x 18) QUAD (Burst of 2) Synchronous SRAMs



Pin Description

Symbol	Pin Number	Description
K, \bar{K}	6B, 6A	Input clock.
C, \bar{C}	6P, 6R	Input clock for output data control.
CQ, \bar{CQ}	11A, 1A	Output echo clock.
\bar{D} off	1H	DLL disable when low.
SA	9A, 4B, 8B, 5C, 6C, 7C, 5N, 6N, 7N, 4P, 5P, 7P, 8P, 3R, 4R, 5R, 7R, 8R, 9R	1M x 36 address inputs.
SA	3A, 9A, 4B, 8B, 5C, 6C, 7C, 5N, 6N, 7N, 4P, 5P, 7P, 8P, 3R, 4R, 5R, 7R, 8R, 9R	2M x 18 address inputs.
D0–D8 D9–D17 D18–D26 D27–D35	10P, 11N, 11M, 10K, 11J, 11G, 10E, 11D, 11C 10N, 9M, 9L, 9J, 10G, 9F, 10D, 9C, 9B 3B, 3C, 2D, 3F, 2G, 3J, 3L, 3M, 2N 1C, 1D, 2E, 1G, 1J, 2K, 1M, 1N, 2P	1M x 36 data inputs.
Q0–Q8 Q9–Q17 Q18–Q26 Q27–Q35	11P, 10M, 11L, 11K, 10J, 11F, 11E, 10C, 11B 9P, 9N, 10L, 9K, 9G, 10F, 9E, 9D, 10B 2B, 3D, 3E, 2F, 3G, 3K, 2L, 3N, 3P 1B, 2C, 1E, 1F, 2J, 1K, 1L, 2M, 1P	1M x 36 data outputs.
D0–D8 D9–D17	10P, 11N, 11M, 10K, 11J, 11G, 10E, 11D, 11C 3B, 3C, 2D, 3F, 2G, 3J, 3L, 3M, 2N	2M x 18 data inputs.
Q0–Q8 Q9–Q17	11P, 10M, 11L, 11K, 10J, 11F, 11E, 10C, 11B 2B, 3D, 3E, 2F, 3G, 3K, 2L, 3N, 3P	2M x 18 data outputs.
\bar{W}	4A	Write control, active low.
\bar{R}	8A	Read control, active low.
$\bar{BW}_0, \bar{BW}_1, \bar{BW}_2, \bar{BW}_3$	7B, 7A, 5A, 5B	1M x 36 byte write control, active low.
\bar{BW}_0, \bar{BW}_1	7B, 5A	2M x 18 byte write control, active low.
V _{REF}	2H, 10H	Input reference level.
V _{DD}	5F, 7F, 5G, 7G, 5H, 7H, 5J, 7J, 5K, 7K	Power supply.
V _{DDQ}	4E, 8E, 4F, 8F, 4G, 8G, 3H, 4H, 8H, 9H, 4J, 8J, 4K, 8K, 4L, 8L	Output power supply.
V _{SS}	2A, 10A, 4C, 8C, 4D, 5D, 6D, 7D, 8D, 5E, 6E, 7E, 6F, 6G, 6H, 6J, 6K, 5L, 6L, 7L, 4M, 5M, 6M, 7M, 8M, 4N, 8N	Power supply.
ZQ	11H	Output driver impedance control.
TMS, TDI, TCK	10R, 11R, 2R	IEEE 1149.1 test inputs (1.8V LVTTTL levels).
TDO	1R	IEEE 1149.1 test output (1.8V LVTTTL level).
NC	3A	1Mx36
NC	7A, 1B, 5B, 9B, 10B, 1C, 2C, 9C, 1D, 9D, 10D, 1E, 2E, 9E, 1F, 9F, 10F, 1G, 9G, 10G, 1J, 2J, 9J, 1K, 2K, 9K, 1L, 9L, 10L, 1M, 2M, 9M, 1N, 9N, 10N, 1P, 2P, 9P	2Mx18

Block Diagram

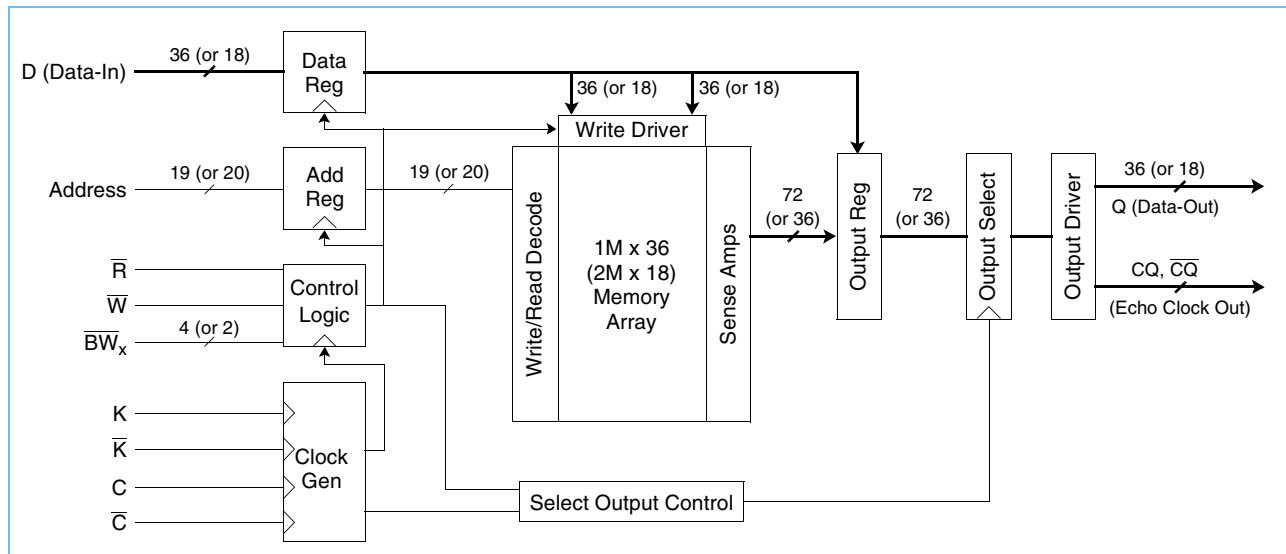

SRAM Features

Read Operations

The SRAM operates continuously in a burst-of-two mode. Read cycles are started by registering \bar{R} in active low state at the rising edge of the K clock. A second set of clocks, C and \bar{C} , are used to control the timing to the outputs. A set of free-running echo clocks, CQ and \bar{CQ} , are produced internally with timings identical to the data-outs. The echo clocks can be used as data capture clocks by the receiver device.

When the C and \bar{C} clocks are connected high, the K and \bar{K} clocks assume the function of those clocks. In this case, the data corresponding to the first address is clocked 1.5 cycles later by the rising edge of the \bar{K} clock. The data corresponding to the second burst is clocked 2 cycles later by the following rising edge of the K clock.

A NOP operation (\bar{R} is high) does not terminate the previous read.

Write Operations

Write operations can also be initiated at every rising edge of the K clock whenever \bar{W} is low. The write address is provided 0.5 cycles later, registered by the rising edge of \bar{K} . Again, the write always occurs in bursts of two.

The write data is provided in an 'early write' mode; that is, the data-in corresponding to the first address of the burst, is presented 0.5 cycles earlier or at the rising edge of the preceding K clock. The data-in corresponding to the second write burst address follows next, registered by the rising edge of \bar{K} .

The data-in provided for writing is initially kept in write buffers. The information on these buffers is written into the array on the following write cycle. A read cycle to the last write address produces data from the write buffers. Similarly, a read address followed by the same write address produces the latest write data. The SRAM maintains data coherency.

During a write, the byte writes independently control which byte of any of the two burst addresses is written (see *X18/X36 Write Truth Tables* on page 9 and *Timing Reference Diagram for Truth Table* on page 8).

Whenever a write is disabled (\overline{W} is high at the rising edge of K), data is not written into the memory.

RQ Programmable Impedance

An external resistor, RQ, must be connected between the ZQ pin on the SRAM and V_{SS} to enable the SRAM to adjust its output driver impedance. The value of RQ must be 5x the value of the intended line impedance driven by the SRAM. For example, an RQ of 250 Ω results in a driver impedance of 50 Ω . The allowable range of RQ to guarantee impedance matching is between 175 Ω and 350 Ω , with the tolerance described in *Programmable Impedance Output Driver DC Electrical Characteristics* on page 13. The RQ resistor should be placed less than two inches away from the ZQ ball on the SRAM module. The capacitance of the loaded ZQ trace must be less than 3 pF.

The ZQ pin can also be directly connected to V_{DDQ} to obtain a minimum impedance setting. ZQ must never be connected to V_{SS} .

Programmable Impedance and Power-Up Requirements

Periodic readjustment of the output driver impedance is necessary as the impedance is greatly affected by drifts in supply voltage and temperature. At power-up, the driver impedance is in the middle of allowable impedances values. The final impedance value is achieved within 1024 clock cycles.

Clock Consideration

This device uses an internal DLL for maximum output data valid window. It can be placed in a stopped-clock mode to minimize power and requires only 1024 cycles to restart.

No clocks can be issued until V_{DD} reaches its allowable operating range.

Single Clock Mode

This device can be also operated in single-clock mode. In this case, C and \overline{C} are both connected high at power-up and must never change. Under this condition, K and \overline{K} will control the output timings.

Either clock pair must have both polarities switching and must never connect to V_{REF} , as they are not differential clocks

Depth Expansion

Separate input and output ports enable easy depth expansion, as each port can be selected and deselected independently. Read and write operations can occur simultaneously without affecting each other. Also, all pending read and write transactions are always completed prior to deselecting the corresponding port.

In the following application example, the second pair of C and \overline{C} clocks is delayed such that the return data meets the data setup and hold times at the bus master.

Application Example

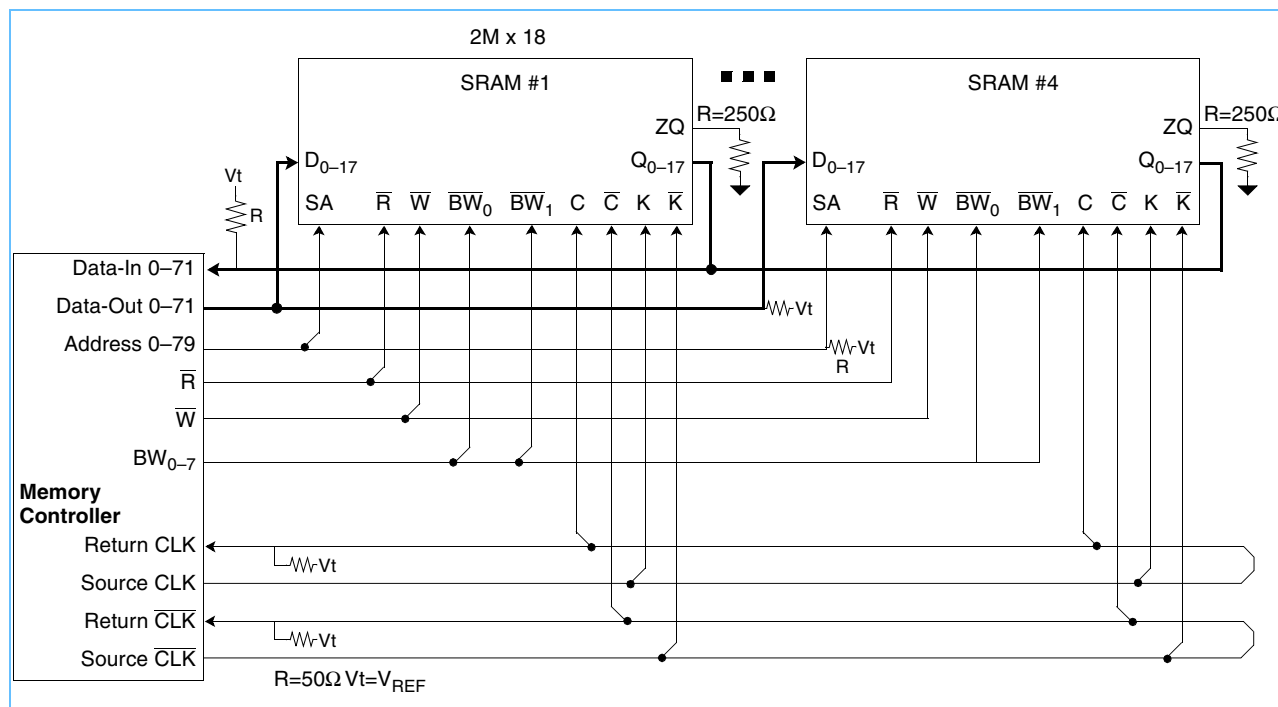

Power-Up and Power-Down Sequences

The following sequence is used for power-up:

1. The power supply inputs must be applied in the following order while keeping $\overline{\text{Doff}}$ in LOW logic state:
 - 1) VDD
 - 2) VDDQ
 - 3) VREF
2. Start applying stable clock inputs (K, $\overline{\text{K}}$, C, and $\overline{\text{C}}$).
3. After clock signals have stabilized, change $\overline{\text{Doff}}$ to HIGH logic state.
4. Once the $\overline{\text{Doff}}$ is switched to HIGH logic state, wait an additional 1024 clock cycles to lock the DLL.

NOTES:

1. The power-down sequence must be done in reverse of the power-up sequence.
2. VDDQ can be allowed to exceed VDD by no more than 0.6V.
3. VREF can be applied concurrently with VDDQ.

State Diagram

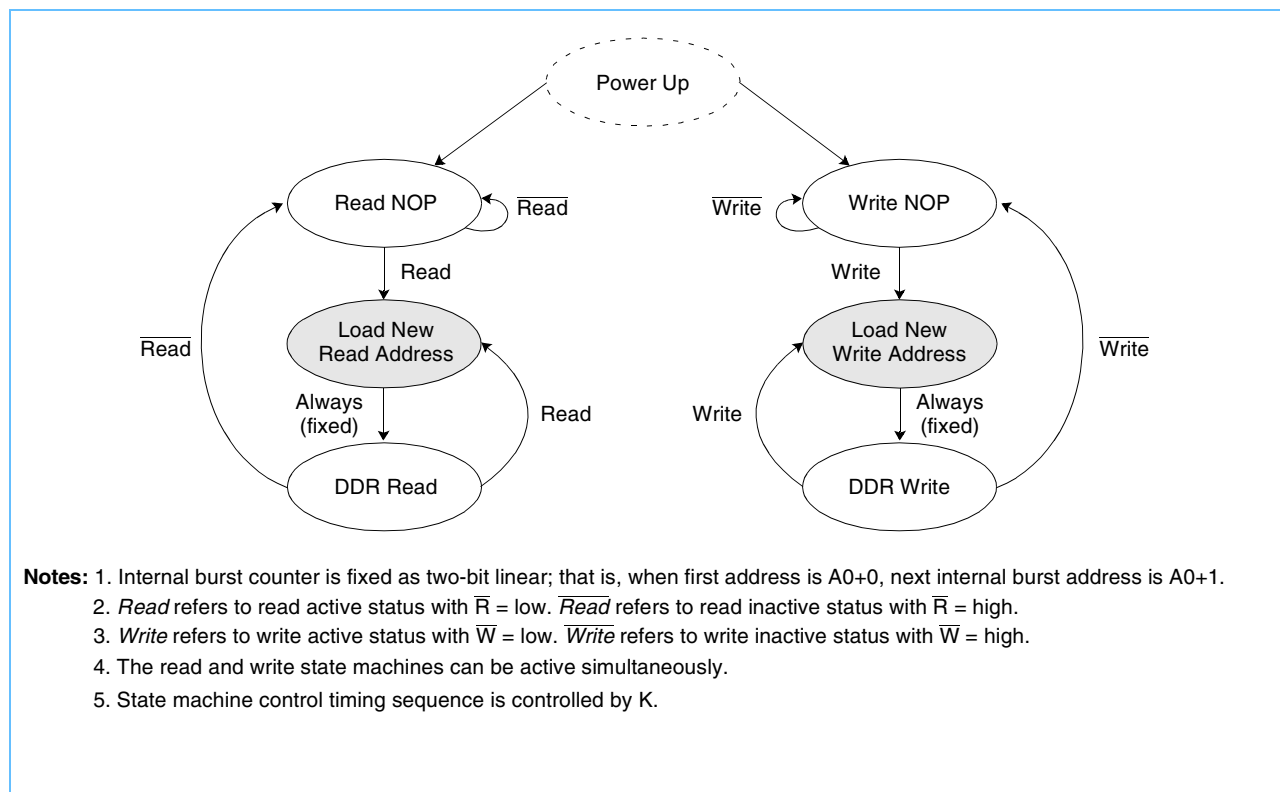

The *Timing Reference Diagram for Truth Table* on page 8 is helpful in understanding the clock and write truth tables, as it shows the cycle relationship between clocks, address, data in, data out, and controls. All read and write commands are issued at the beginning of cycle “t”.



Timing Reference Diagram for Truth Table

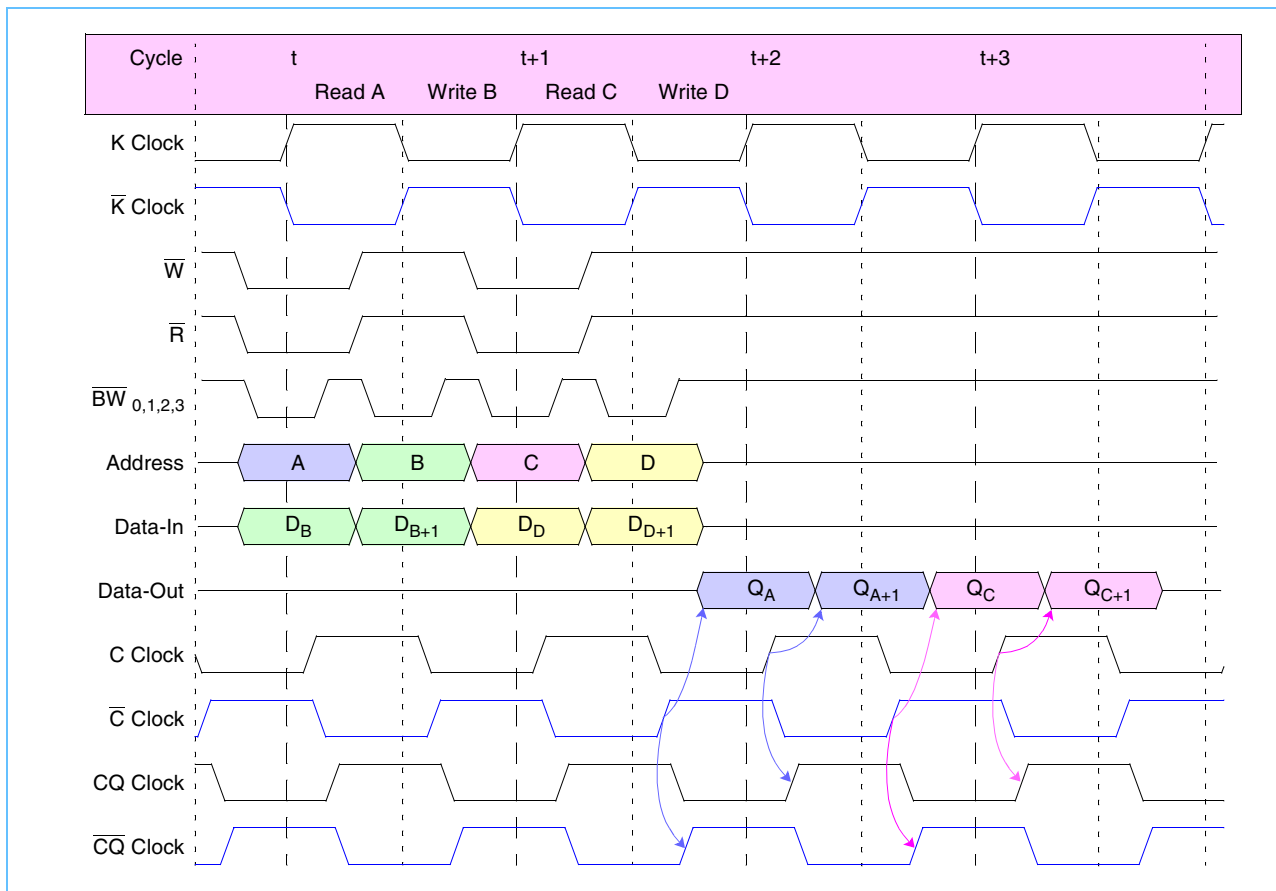

Clock Truth Table (Use the following table with the *Timing Reference Diagram for Truth Table*.)

Mode	Clock	Controls		Data-In		Data-Out	
	K	R-bar	W-bar	D _B	D _{B+1}	Q _A	Q _{A+1}
Stop Clock	Stop	X	X	Previous state	Previous State	Previous state	Previous state
No Operation (NOP)	L→H	H	H	X	X	High-Z	High-Z
Read A	L→H	L	X	X	X	D out at C-bar (t + 1.5)	D out at C (t + 2)
Write B	L→H	X	L	D in at K (t)	D in at K-bar (t + 0.5)	X	X

Notes:

1. The internal burst counter is always fixed as two-bit.
2. X = don't care; H = logic "1"; L = logic "0".
3. A read operation is started when control signal R-bar is active low
4. A write operation is started when control signal W-bar is active low. Before entering into the stop clock, all pending read and write commands must be completed.
5. For timing definitions, refer to the *AC Characteristics* on page 15-16. Signals must have AC specifications at timings indicated in parenthesis with respect to switching clocks K, K-bar, C, and C-bar.

X36 Write Truth Table Use the following table with the *Timing Reference Diagram for Truth Table* on page 8.

Operation	K(t)	\bar{K} (t + 0.5)	\overline{BW}_0	\overline{BW}_1	\overline{BW}_2	\overline{BW}_3	D _B	D _{B+1}
Write Byte 0	L→H		L	H	H	H	D0-8 (t)	
Write Byte 1	L→H		H	L	H	H	D9-17 (t)	
Write Byte 2	L→H		H	H	L	H	D18-26 (t)	
Write Byte 3	L→H		H	H	H	L	D27-35 (t)	
Write All Bytes	L→H		L	L	L	L	D0-35 (t)	
Abort Write	L→H		H	H	H	H	Don't care	
Write Byte 0		L→H	L	H	H	H		D0-8 (t + 0.5)
Write Byte 1		L→H	H	L	H	H		D9-17 (t + 0.5)
Write Byte 2		L→H	H	H	L	H		D18-26 (t + 0.5)
Write Byte 3		L→H	H	H	H	L		D27-35 (t + 0.5)
Write All Bytes		L→H	L	L	L	L		D0-35 (t + 0.5)
Abort Write		L→H	H	H	H	H		Don't care

Notes;

1. For all cases, \overline{W} must be active low during the rising edge of K occurring at time t.
2. For timing definitions, refer to the *AC Characteristics* on page 15-16. Signals must have AC specifications with respect to switching clocks K and \bar{K} .

X18 Write Truth Table (Use this table with the *Timing Reference Diagram for Truth Table* on page 8.)

Operation	K(t)	\bar{K} (t + 0.5)	\overline{BW}_0	\overline{BW}_1	D _B	D _{B+1}
Write Byte 0 on B	L→H		L	H	D0–8 (t)	
Write Byte 1 on B	L→H		H	L	D9–17 (t)	
Write All Bytes on B	L→H		L	L	D0–17 (t)	
Abort Write on B	L→H		H	H	Don't care	
Write Byte 1 on B+1		L→H	L	H		D0–8(t + 0.5)
Write Byte 2 on B+1		L→H	H	L		D9–17(t + 0.5)
Write All Bytes on B+1		L→H	L	L		D0–17(t + 0.5)
Abort Write on B+1		L→H	H	H		Don't care

Notes;

1. Refer to *Timing Reference Diagram for Truth Table* on page 8. Cycle time starts at n and is referenced to the K clock.
2. For all cases, \overline{W} must be active low during the rising edge of K occurring at t.
3. For timing definitions, refer to the *AC Characteristics* on page 15-16. Signals must have AC specs with respect to switching clocks K and \bar{K} .



Absolute Maximum Ratings

Item	Symbol	Rating	Units
Power supply voltage	VDD	-0.5 to 2.6	V
Output power supply voltage	VDDQ	-0.5 to 2.6	V
Input voltage	VIN	-0.5 to 2.6	V
Data out voltage	VDOUT	-0.5 to 2.6	V
Junction temperature	TJ	110	°C
Storage temperature	TSTG	-55 to +125	°C

Note: Stresses greater than those listed in this table can cause permanent damage to the device. This is a stress rating only and functional operation of the device at these or any other conditions above those indicated in the operational sections of this datasheet is not implied. Exposure to absolute maximum rating conditions for extended periods may affect reliability.

Operating Temperature Range

Range	Symbol	Rating	Unit
Commercial	TA	0 to 70	°C
Industrial	TA	-40 to +85	°C

Recommended DC Operating Conditions (Over the operating temperature)

Parameter	Symbol	Minimum	Typical	Maximum	Units	Notes
Supply voltage	V_{DD}	1.8 - 5%		1.8 + 5%	V	1
Output driver supply voltage	V_{DDQ}	1.4		1.9	V	1
Input high voltage	V_{IH}	$V_{REF} + 0.1$		$V_{DDQ} + 0.3$	V	1, 2
Input low voltage	V_{IL}	-0.3		$V_{REF} - 0.1$	V	1, 3
Input reference voltage	V_{REF}	0.68		0.95	V	1, 5
Clocks signal voltage	V_{IN-CLK}	-0.3		$V_{DDQ} + 0.3$	V	1, 4

1. All voltages are referenced to V_{SS} . All V_{DD} , V_{DDQ} , and V_{SS} pins must be connected.
2. $V_{IH}(\text{Max})$ AC = See *Overshoot and Undershoot Timings*.
3. $V_{IL}(\text{Min})$ AC = See *Overshoot and Undershoot Timings*.
4. V_{IN-CLK} specifies the maximum allowable DC excursions of each clock (K, \bar{K} , C, and \bar{C}).
5. Peak-to-peak AC component superimposed on V_{REF} may not exceed 5% of V_{REF} .

Overshoot and Undershoot Timings

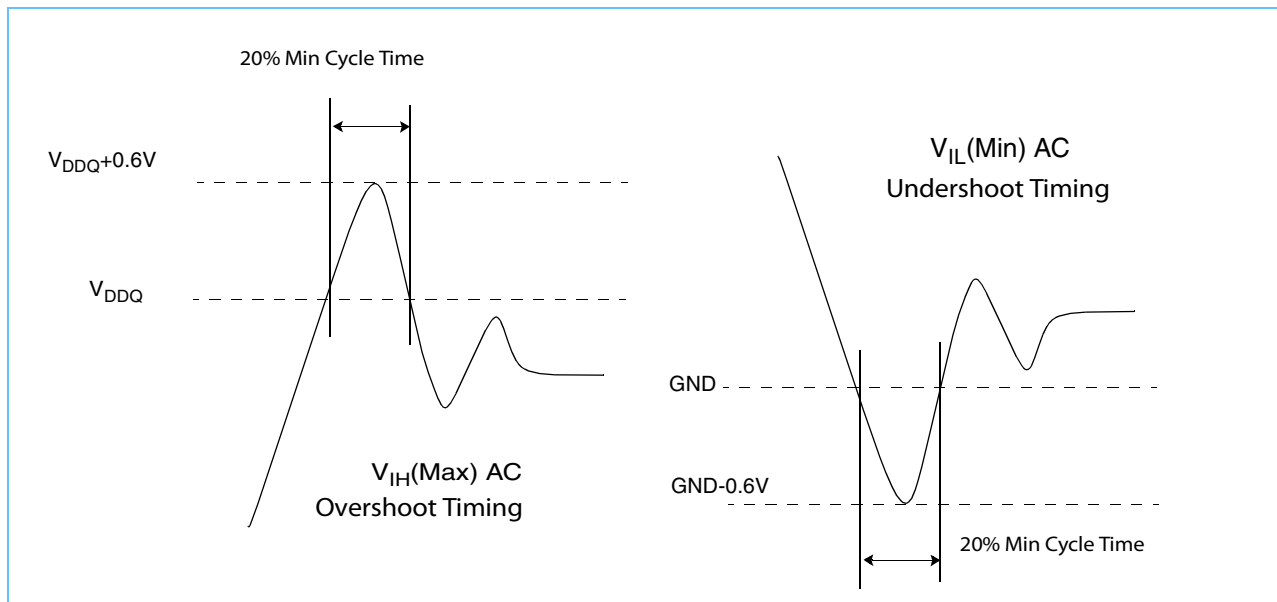

PBGA Thermal Characteristics

Item	Symbol	Rating	Units
Thermal resistance junction to ambient (airflow = 1m/s)	$R_{\theta JA}$	20.4	$^{\circ}\text{C/W}$
Thermal resistance junction to case	$R_{\theta JC}$	4.0	$^{\circ}\text{C/W}$
Thermal resistance junction to pins	$R_{\theta JB}$	3.23	$^{\circ}\text{C/W}$

Capacitance ($V_{DD} = 1.8V -5\%, +5\%$, $f = 1MHz$. Over the operating temperature range.)

Parameter	Symbol	Test Condition	Maximum	Units
Input capacitance	C_{IN}	$V_{IN} = 0V$	4	pF
Data-in capacitance (D0–D35)	C_{DIN}	$V_{DIN} = 0V$	4	pF
Data-out capacitance (Q0–Q35)	C_{OUT}	$V_{OUT} = 0V$	4	pF
Clocks Capacitance (K, \bar{K} , C, \bar{C})				

DC Electrical Characteristics ($V_{DD} = 1.8V -5\%, +5\%$. Over the operating temperature range.)

Parameter	Symbol	Minimum	Maximum	Units	Notes
x36 average power supply operating current ($I_{OUT} = 0$, $V_{IN} = V_{IH}$ or V_{IL})	I_{DD30}	—	800	mA	1, 3
	I_{DD40}^1	—	700		
	I_{DD50}	—	600		
x18 average power supply operating current ($I_{OUT} = 0$, $V_{IN} = V_{IH}$ or V_{IL})	I_{DD30}	—	800	mA	1, 3
	I_{DD40}^1	—	700		
	I_{DD50}	—	600		
Power supply standby current ($R = V_{IH}$, $W = V_{IH}$. All other inputs = V_{IH} or V_{IH} , $I_{IH} = 0$)	I_{SBSS}	—	200	mA	1
Input leakage current, any input (except JTAG) ($V_{IN} = V_{SS}$ or V_{DD})	I_{LI}	-2	+2	uA	
Output leakage current ($V_{OUT} = V_{SS}$ or V_{DDQ} ; Q in High-Z)	I_{LO}	-5	+5	uA	
Output "high" level voltage ($I_{OH} = -6mA$)	V_{OH}	$V_{DDQ} - 0.4$	V_{DDQ}	V	2, 4
Output "low" level voltage ($I_{OL} = +6mA$)	V_{OL}	V_{SS}	$V_{SS} + 0.4$	V	2, 4
JTAG leakage current ($V_{IN} = V_{SS}$ or V_{DD})	I_{LJTAG}	-100	+100	uA	5

1. I_{OUT} = chip output current.
2. Minimum impedance output driver.
3. The numeric suffix indicates the part operating at speed, as indicated in *AC Characteristics* on page 15-16 (that is, I_{DD25} indicates 2.5ns cycle time).
4. JEDEC Standard JESD8-6 Class 1 compatible.
5. For JTAG inputs only.

Typical AC Input Characteristics

Item	Symbol	Minimum	Maximum	Notes
AC input logic high	$V_{IH} (ac)$	$V_{REF} + 0.2$		1, 2, 3, 4
AC input logic low	$V_{IL} (ac)$		$V_{REF} - 0.2$	1, 2, 3, 4
Clock input logic high (K, \bar{K} , C, \bar{C})	$V_{IH-CLK} (ac)$	$V_{REF} + 0.2$		1, 2, 3
Clock input logic low (K, \bar{K} , C, \bar{C})	$V_{IL-CLK} (ac)$		$V_{REF} - 0.2$	1, 2, 3

1. The peak-to-peak AC component superimposed on V_{REF} may not exceed 5% of the DC component of V_{REF} .
2. Performance is a function of V_{IH} and V_{IL} levels to clock inputs.
3. See the *AC Input Definition* diagram.
4. See the *AC Input Definition* diagram. The signals should swing monotonically with no steps rail-to-rail with input signals never ringing back past $V_{IH} (AC)$ and $V_{IL} (AC)$ during the input setup and input hold window. $V_{IH} (AC)$ and $V_{IL} (AC)$ are used for timing purposes only.

AC Input Definition

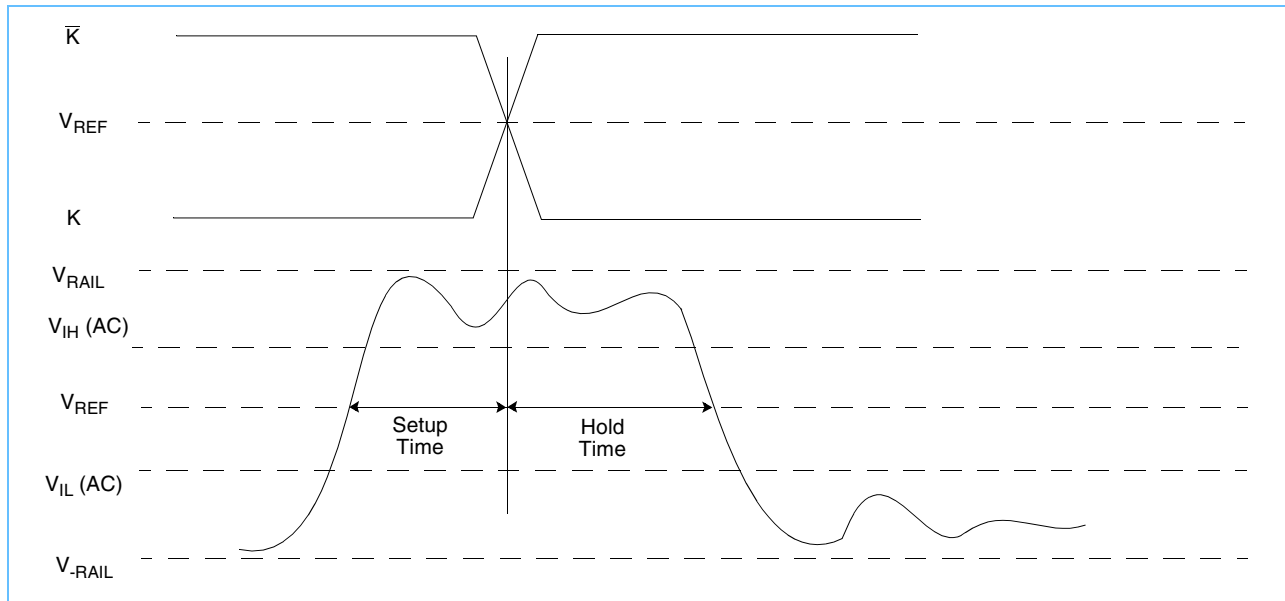

Programmable Impedance Output Driver DC Electrical Characteristics

($V_{DD} = 1.8V -5\%, +5\%$, $V_{DDQ} = 1.5, 1.8V$. Over the operating temperature range.)

Parameter	Symbol	Minimum	Maximum	Units	Notes
Output "high" level voltage	V_{OH}	$V_{DDQ} / 2$	V_{DDQ}	V	1, 3
Output "low" level voltage	V_{OL}	V_{SS}	$V_{DDQ} / 2$	V	2, 3

1. $I_{OH} = \left(\frac{V_{DDQ}}{2} \right) / \left(\frac{RQ}{5} \right) \pm 15\%$ @ $V_{OH} = V_{DDQ} / 2$ For: $175\Omega \leq RQ \leq 350\Omega$
2. $I_{OL} = \left(\frac{V_{DDQ}}{2} \right) / \left(\frac{RQ}{5} \right) \pm 15\%$ @ $V_{OL} = V_{DDQ} / 2$ For: $175\Omega \leq RQ \leq 350\Omega$
3. Parameter tested with $RQ = 250\Omega$ and $V_{DDQ} = 1.5V$.

AC Test Conditions ($V_{DD} = 1.8V -5\%, +5\%$, $V_{DDQ} = 1.5, 1.8V$. Over the operating temperature range.)

Parameter	Symbol	Conditions	Units	Notes
Output driver supply voltage	V_{DDQ}	1.5, 1.8	V	
Input high level	V_{IH}	1.25	V	
Input Low Level	V_{IL}	0.25	V	
Input reference voltage	V_{REF}	0.75	V	
Input rise time	T_R	0.35	ns	
Input fall time	T_F	0.35	ns	
Output timing reference level		$V_{DDQ}/2$	V	
Output load conditions				1, 2
1. See AC Test Loading. 2. Parameter tested with $R_Q = 250$ and $V_{DDQ} = 1.5V$.				

AC Test Loading

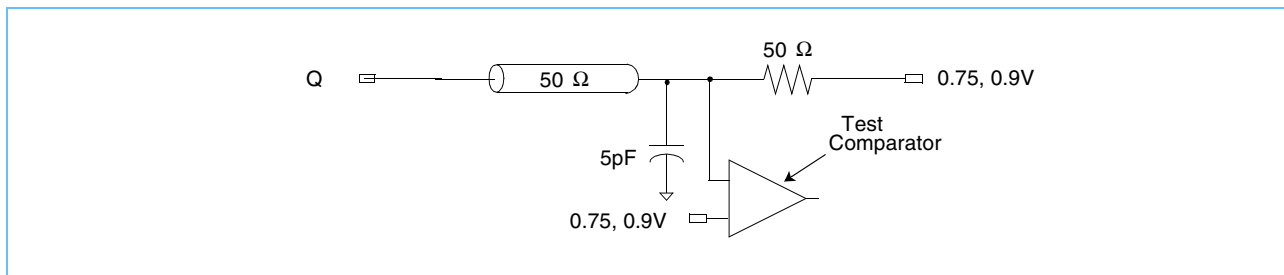

36 Mb (1M x 36 & 2M x 18) QUAD (Burst of 2) Synchronous SRAMs



AC Characteristics ($V_{DD} = 1.8V -5\%, +5\%$. Over the operating temperature range.)

Parameter	Symbol	30 (300MHz)		Units	Notes
		Min	Max		
Clock					
Cycle time (K, \bar{K} , C, \bar{C})	t_{KHKH}	3.3	7.5	ns	
Clock phase jitter (K, \bar{K} , C, \bar{C})	t_{KC-VAR}		0.12	ns	
Clock high pulse (K, \bar{K} , C, \bar{C})	t_{KHKL}	1.32		ns	
Clock low pulse (K, \bar{K} , C, \bar{C})	t_{KLKH}	1.32		ns	
Clock to \bar{clock} ($K_H > \bar{K}_H, C_H > \bar{C}_H$)	$t_{KH\bar{K}H}$	1.35		ns	
Clock to data clock ($K_H > C_H, \bar{K}_H > \bar{C}_H$)	t_{KHCH}	0.0	1.35	ns	
DLL lock (K, C)	$t_{KC-lock}$	1024		cycle	
K static to DLL reset	$t_{KC-reset}$	30		ns	
Output Times					
C, \bar{C} high to output valid	t_{CHQV}		0.40	ns	1, 3
C, \bar{C} high to output hold	t_{CHQX}	-0.40		ns	1, 3
C, \bar{C} high to echo clock valid	t_{CHCQV}		0.35	ns	3
C, \bar{C} high to echo clock hold	t_{CHCQX}	-0.35		ns	3
CQ, $\bar{C}\bar{Q}$ high to output valid	t_{CQHQV}		0.25	ns	1, 3
CQ, $\bar{C}\bar{Q}$ high to output hold	t_{CQHQX}	-0.25		ns	1, 3
C high to output high-Z	t_{CHQZ}		0.33	ns	1, 3
C high to output low-Z	t_{CHQX1}	-0.33		ns	1, 3
Setup Times					
Address valid to K, \bar{K} rising edge	t_{AVKH}	0.33	—	ns	2
Control inputs valid to K rising edge	t_{IVKH}	0.33	—	ns	2
Data-in valid to K, \bar{K} rising edge	t_{DVKH}	0.33	—	ns	2
Hold Times					
K rising edge to address hold	t_{KHAX}	0.33	—	ns	2
K rising edge to control inputs hold	t_{KHIX}	0.33	—	ns	2
K, \bar{K} rising edge to data-in hold	t_{KHDX}	0.33	—	ns	2

1. See AC Test Loading on page 14.
2. During normal operation, V_{IH} , V_{IL} , T_{RISE} , and T_{FALL} of inputs must be within 20% of V_{IH} , V_{IL} , T_{RISE} , and T_{FALL} of clock.
3. If C, \bar{C} are tied high, then K, \bar{K} become the references for C, \bar{C} timing parameters.

AC Characteristics ($V_{DD} = 1.8V -5\%, +5\%$. Over the operating temperature range.)

Parameter	Symbol	40 (250MHz)		50 ⁴ (200MHz)		Units	Notes
		Min	Max	Min	Max		
Clock							
Cycle time (K, \bar{K} , C, \bar{C})	t_{KHKH}	4.0	7.5	5.0	7.5	ns	
Clock phase jitter (K, \bar{K} , C, \bar{C})	t_{KC-VAR}		0.2		0.2	ns	
Clock high pulse (K, \bar{K} , C, \bar{C})	t_{KHKL}	1.6		2.0		ns	
Clock low pulse (K, \bar{K} , C, \bar{C})	t_{KLKH}	1.6		2.0		ns	
Clock to clock ($K_H > \bar{K}_H$, $C_H > \bar{C}_H$)	$t_{KH\bar{K}H}$	1.8		2.2		ns	
Clock to data clock ($K_H > C_H$, $\bar{K}_H > \bar{C}_H$)	t_{KHCH}	0.0	1.35	0.0	1.35	ns	
DLL lock (K, C)	$t_{KC-lock}$	1024		1024		cycle	
K static to DLL reset	$t_{KC-reset}$	30		30		ns	
Output Times							
C, \bar{C} high to output valid	t_{CHQV}		0.45		0.45	ns	1, 3
C, \bar{C} high to output hold	t_{CHQX}	-0.45		-0.45		ns	1, 3
C, \bar{C} high to echo clock valid	t_{CHCQV}		0.40		0.4	ns	3
C, \bar{C} high to echo clock hold	t_{CHCQX}	-0.40		-0.40		ns	3
CQ, $\bar{C}\bar{Q}$ High to output valid	t_{CQHQV}		0.30		0.40	ns	1, 3
CQ, $\bar{C}\bar{Q}$ high to output hold	t_{CQHQX}	-0.30		-0.40		ns	1, 3
C High to output high-Z	t_{CHQZ}		0.35		0.38	ns	1, 3
C High to output low-Z	t_{CHQX1}	-0.35		-0.38		ns	1, 3
Setup Times							
Address valid to K, \bar{K} rising edge	t_{AVKH}	0.35	—	0.4	—	ns	2
Control inputs valid to K rising edge	t_{IVKH}	0.35	—	0.4	—	ns	2
Data-in valid to K, \bar{K} rising edge	t_{DVKH}	0.35	—	0.4	—	ns	2
Hold Times							
K rising edge to address hold	t_{KHAX}	0.35	—	0.4	—	ns	2
K rising edge to Control Inputs Hold	t_{KHIX}	0.35	—	0.4	—	ns	2
K, \bar{K} rising edge to data-in hold	t_{KHDX}	0.35	—	0.4	—	ns	2

1. See *AC Test Loading* on page 14.
2. During normal operation, V_{IH} , V_{IL} , T_{RISE} , and T_{FALL} of inputs must be within 20% of V_{IH} , V_{IL} , T_{RISE} , and T_{FALL} of clock.
3. If C, \bar{C} are tied high, then K, \bar{K} become the references for C, \bar{C} timing parameters.

Read and Deselect Cycles Timing Diagram

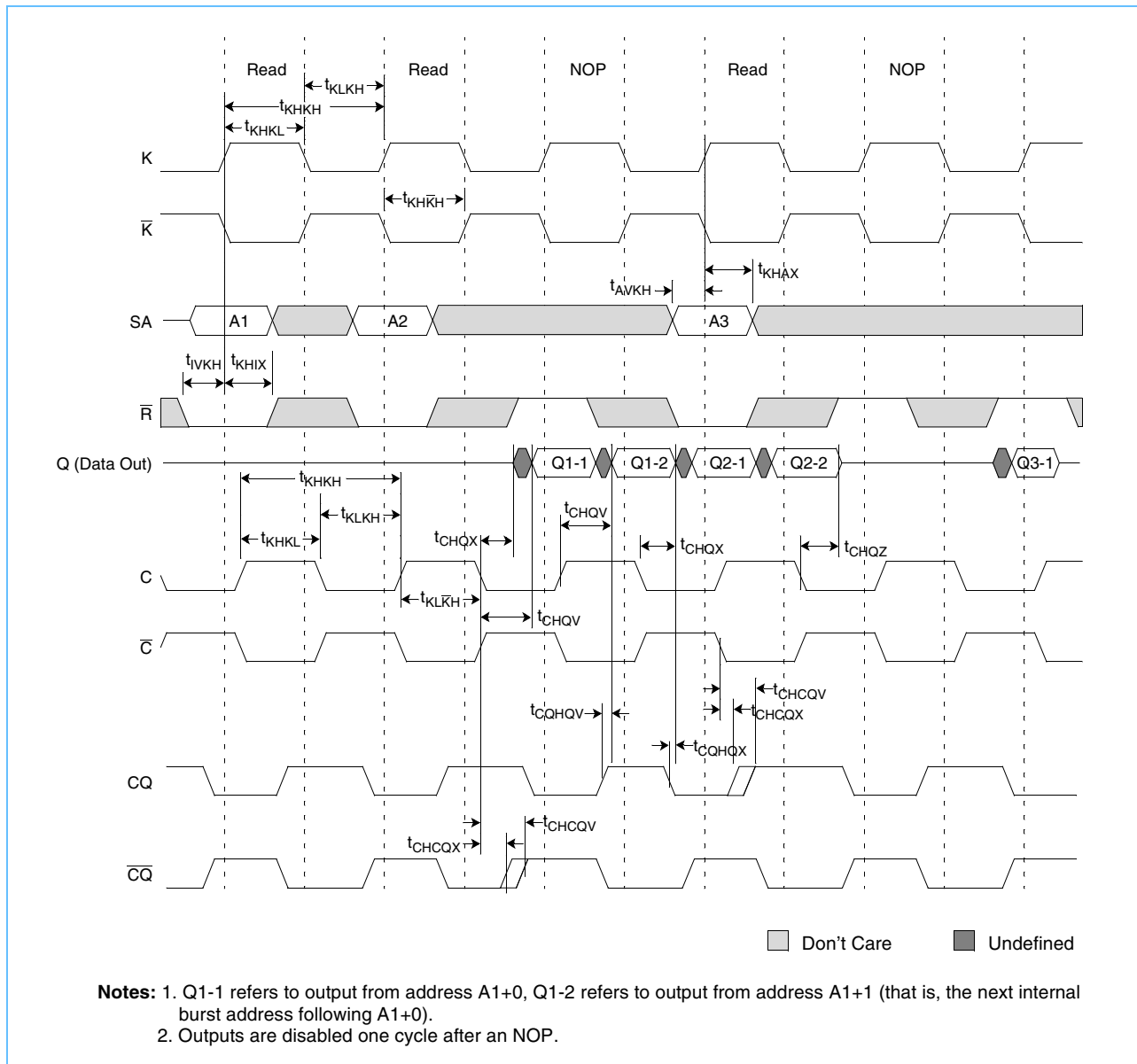

Write and NOP Timing Diagram

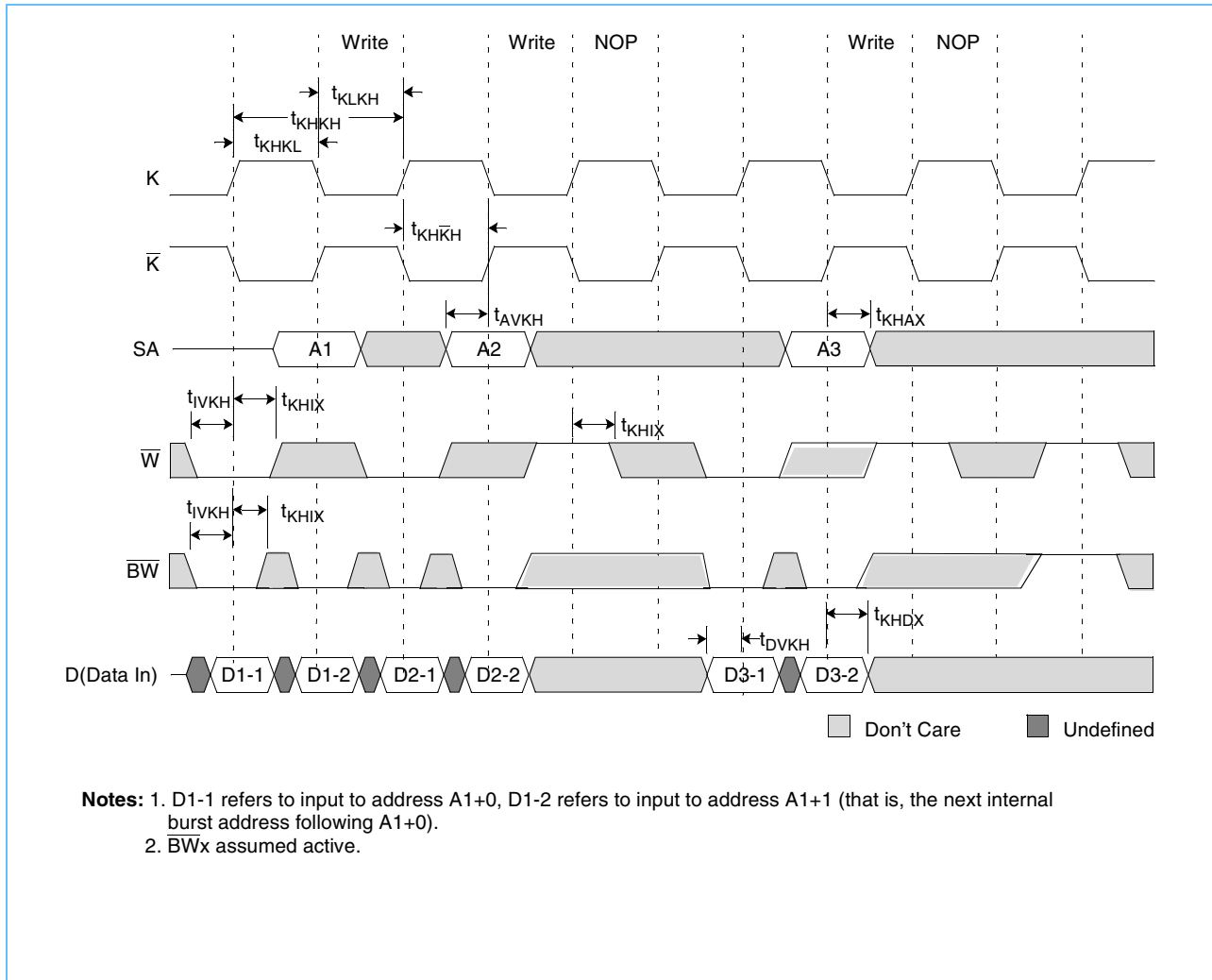

Read, Write, and NOP Timing Diagram

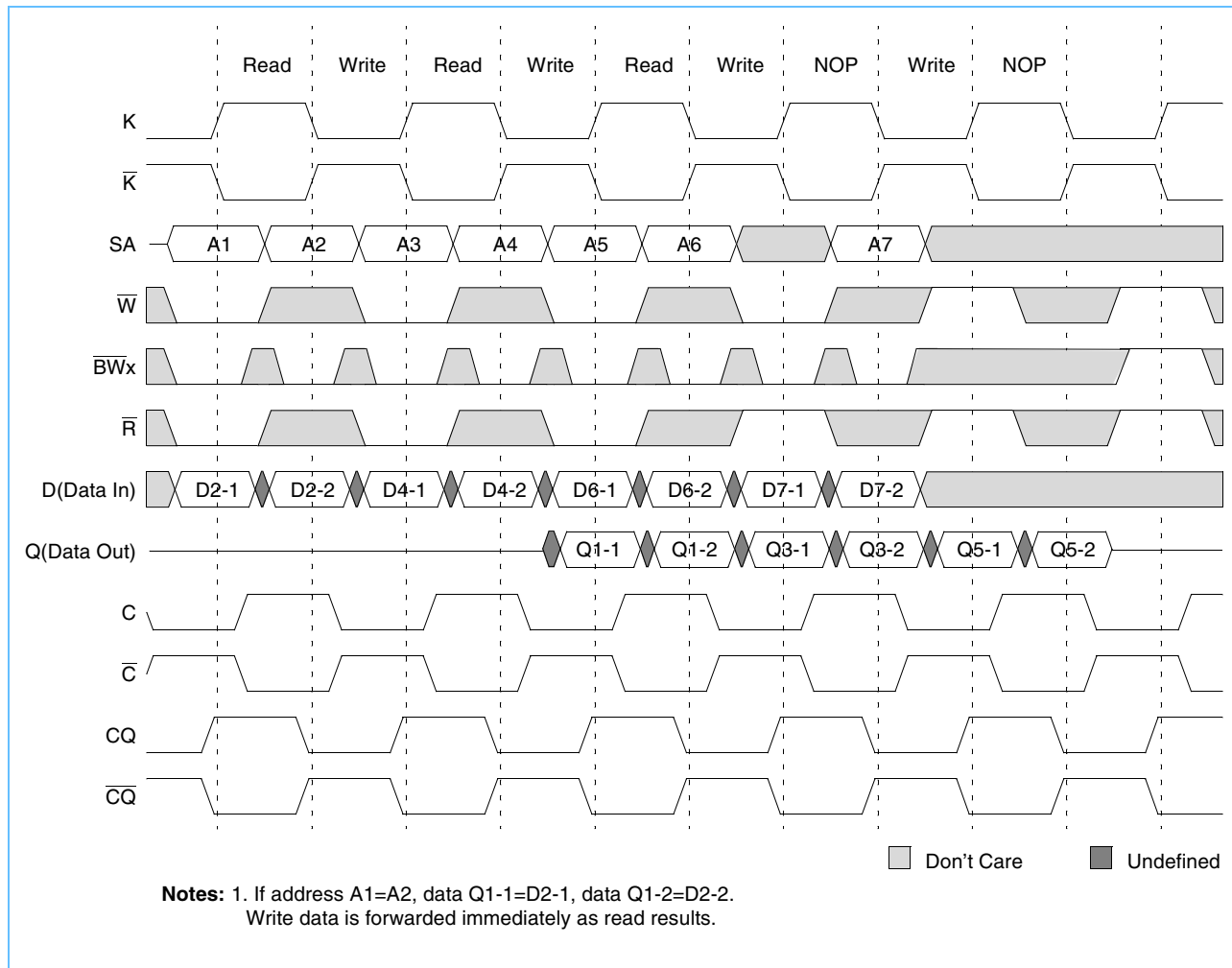

IEEE 1149.1 TAP and Boundary Scan

The SRAM provides a limited set of JTAG functions to test the interconnection between SRAM I/Os and printed circuit board traces or other components. There is no multiplexer in the path from I/O pins to the RAM core.

In conformance with IEEE Standard 1149.1, the SRAM contains a TAP controller, instruction register, boundary scan register, bypass register, and ID register.

The TAP controller has a standard 16-state machine that resets internally on power-up. Therefore, a TRST signal is not required.

Signal List

- TCK: test clock
- TMS: test mode select
- TDI: test data-in
- TDO: test data-out

JTAG DC Operating Characteristics (Over the operating temperature range.) Operates with JEDEC Standard 8-5 (1.8V) logic signal levels

Parameter	Symbol	Minimum	Typical	Maximum	Units	Notes
JTAG input high voltage	V_{IH1}	1.3	—	$V_{DD}+0.3$	V	1
JTAG input low voltage	V_{IL1}	-0.3	—	0.5	V	1
JTAG output high level	V_{OH1}	$V_{DD}-0.4$	—	V_{DD}	V	1, 2
JTAG output low level	V_{OL1}	V_{SS}	—	0.4	V	1, 3

1. All JTAG inputs and outputs are LVTTTL-compatible.
 2. $I_{OH1} \geq -12\text{mA}$
 3. $I_{OL1} \geq +12\text{mA}$.

JTAG AC Test Conditions ($V_{DD} = 1.8\text{V} -5\%, +5\%$. Over the operating temperature range)

Parameter	Symbol	Conditions	Units
Input pulse high level	V_{IH1}	1.3	V
Input pulse low level	V_{IL1}	0.5	V
Input rise time	T_{R1}	1.0	ns
Input fall time	T_{F1}	1.0	ns
Input and output timing reference level		0.9	V

JTAG AC Characteristics ($V_{DD} = 1.8V -5\%, +5\%$. Over the operating temperature range.)

Parameter	Symbol	Minimum	Maximum	Units	Notes
TCK cycle time	t_{THTH}	20	—	ns	
TCK high pulse width	t_{THTL}	7	—	ns	
TCK low pulse width	t_{TLTH}	7	—	ns	
TMS setup	t_{MVTH}	4	—	ns	
TMS hold	t_{THMX}	4	—	ns	
TDI setup	t_{DVTH}	4	—	ns	
TDI hold	t_{THDX}	4	—	ns	
TCK low to valid data	t_{TLOV}	—	7	ns	1

1. See AC Test Loading on page 14.

JTAG Timing Diagram

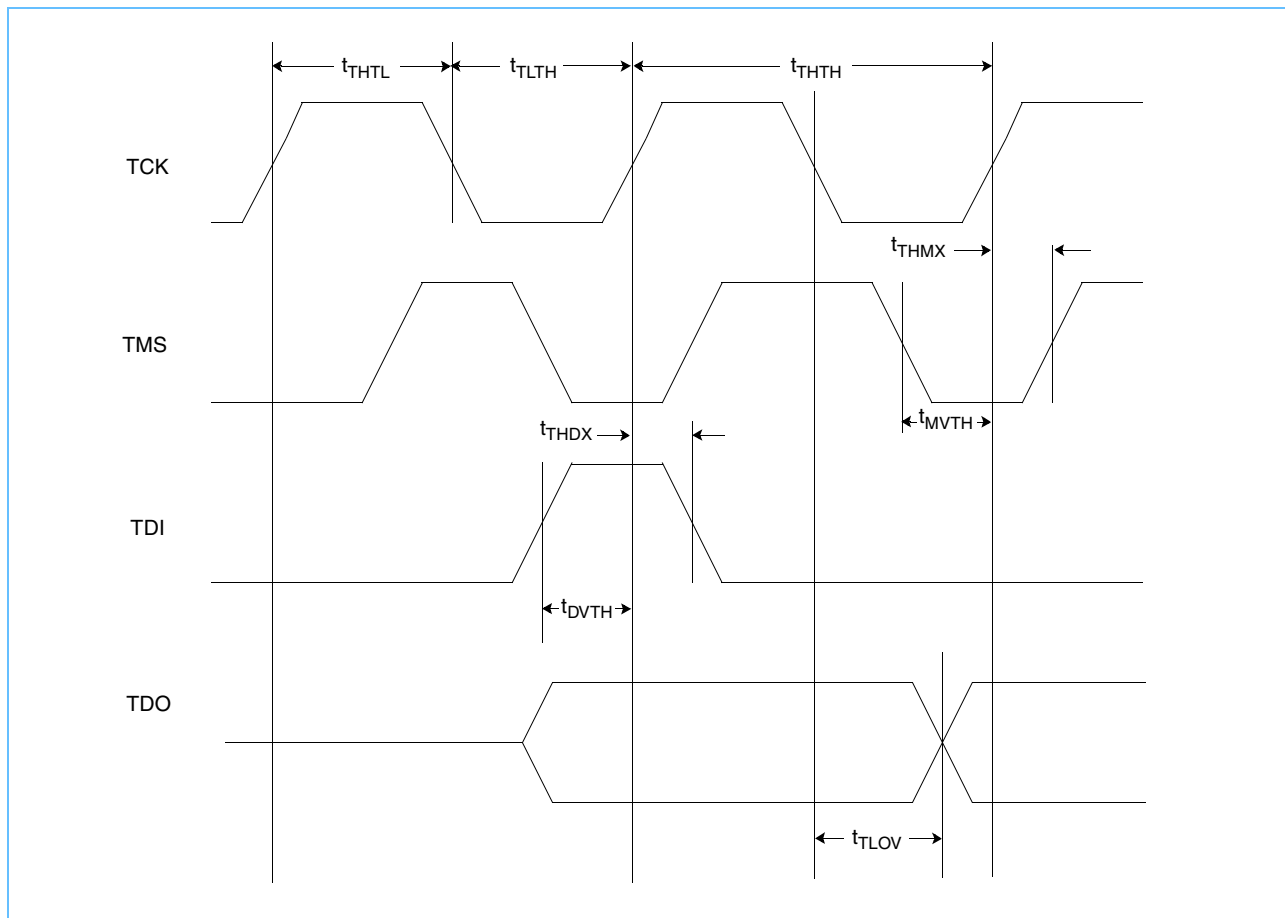



Scan Register Definition

Register Name	Bit Size x18 or x36
Instruction	3
Bypass	1
ID	32
Boundary Scan	109

ID Register Definition

Part	Field Bit Number and Description			
	Revision Number (31:29)	Part Configuration (28:12)	JEDEC Code (11:1)	Start Bit (0)
2M x 18	000	00def0wx0t0q0b0s0	000 101 001 00	1
1M x 36	000	00def0wx0t0q0b0s0	000 101 001 00	1

Part Configuration Definition:

def = 010 for 36Mb
 wx = 11 for x36, 10 for x18
 t = 1 for DLL, 0 for non-DLL
 q = 1 for QDB2, 0 for DDR
 b = 1 for burst of 4, 0 for burst of 2
 s = 1 for separate I/O, 0 for common I/O

Instruction Set

Code	Instruction	TDO Output	Notes
000	EXTEST	Boundary Scan Register	2,6
001	IDCODE	32-bit Identification Register	
010	SAMPLE-Z	Boundary Scan Register	1, 2
011	PRIVATE	Do not use	5
100	SAMPLE	Boundary Scan Register	4
101	PRIVATE	Do not use	5
110	PRIVATE	Do not use	5
111	BYPASS	Bypass Register	3

1. Places Qs in high-Z in order to sample all input data, regardless of other SRAM inputs.
2. TDI is sampled as an input to the first ID register to allow for the serial shift of the external TDI data.
3. BYPASS register is initiated to V_{SS} when BYPASS instruction is invoked. The BYPASS register also holds the last serially loaded TDI when exiting the shift-DR state.
4. SAMPLE instruction does not place DQs in high-Z.
5. This instruction is reserved. Invoking this instruction will cause improper SRAM functionality.
6. This EXTEST is not IEEE 1149.1-compliant. By default, it places Q in high-Z. If the internal register on the scan chain is set high, Q will be updated with information loaded via a previous SAMPLE instruction. The actual transfer occurs during the update IR state after EXTEST is loaded. The value of the internal register can be changed during SAMPLE and EXTEST only.

List of IEEE 1149.1 Standard Violations

- 7.2.1.b, e
- 7.7.1.a-f
- 10.1.1.b, e
- 10.7.1.a-d
- 6.1.1.d

JTAG Block Diagram

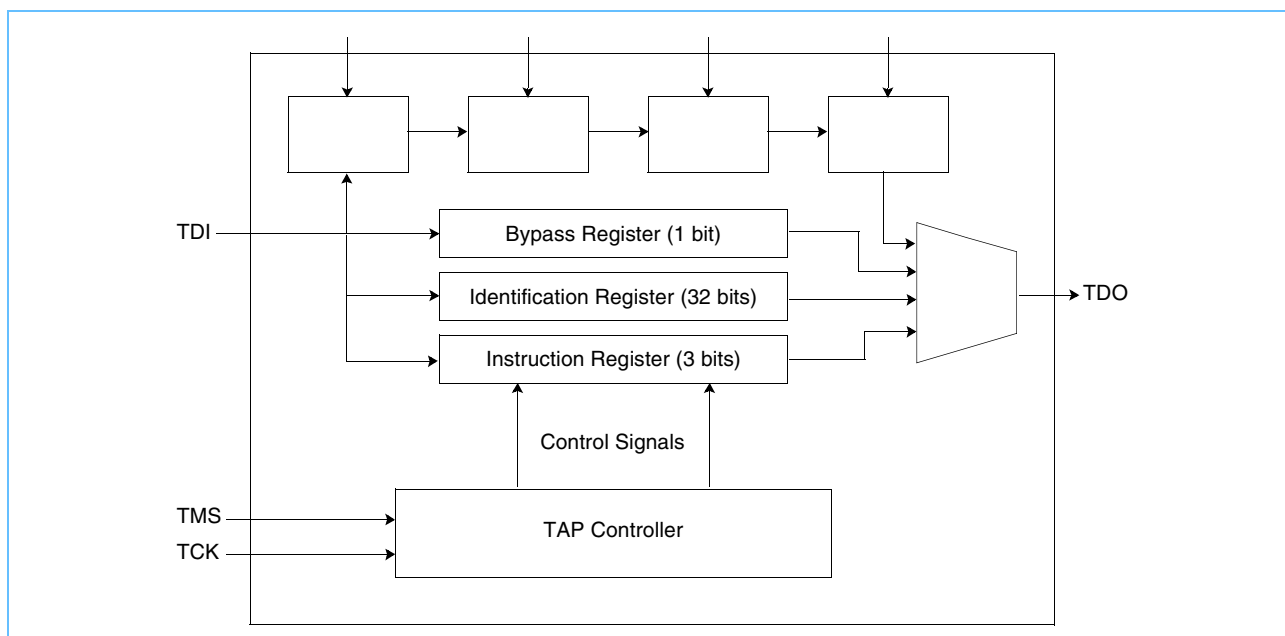

TAP Controller State Machine



36 Mb (1M x 36 & 2M x 18) QUAD (Burst of 2) Synchronous SRAMs



Order	Pin ID
1	6R
2	6P
3	6N
4	7P
5	7N
6	7R
7	8R
8	8P
9	9R
10	11P
11	10P
12	10N
13	9P
14	10M
15	11N
16	9M
17	9N
18	11L
19	11M
20	9L
21	10L
22	11K
23	10K
24	9J
25	9K
26	10J
27	11J
28	11H
29	10G
30	9G
31	11F
32	11G
33	9F
34	10F
35	11E
36	10E

Order	Pin ID
37	10D
37	9E
39	10C
40	11D
41	9C
42	9D
43	11B
44	11C
45	9B
46	10B
47	11A
48	10A
49	9A
50	8B
51	7C
52	6C
53	8A
54	7A
55	7B
56	6B
57	6A
58	5B
59	5A
60	4A
61	5C
62	4B
63	3A
64	2A
65	1A
66	2B
67	3B
68	1C
69	1B
70	3D
71	3C
72	1D

Order	Pin ID
73	2C
74	3E
75	2D
76	2E
77	1E
78	2F
79	3F
80	1G
81	1F
82	3G
83	2G
84	1H
85	1J
86	2J
87	3K
88	3J
89	2K
90	1K
91	2L
92	3L
93	1M
94	1L
95	3N
96	3M
97	1N
98	2M
99	3P
100	2N
101	2P
102	1P
103	3R
104	4R
105	4P
106	5P
107	5N
108	5R
109	Internal

Note:

- 1) NC pins as defined on *FBGA pinouts* on page 2 are read as "don't cares".
- 2) State of Internal pin (#109) is loaded via JTAG

36 Mb (1M x 36 & 2M x 18)
 QUAD (Burst of 2) Synchronous SRAMs

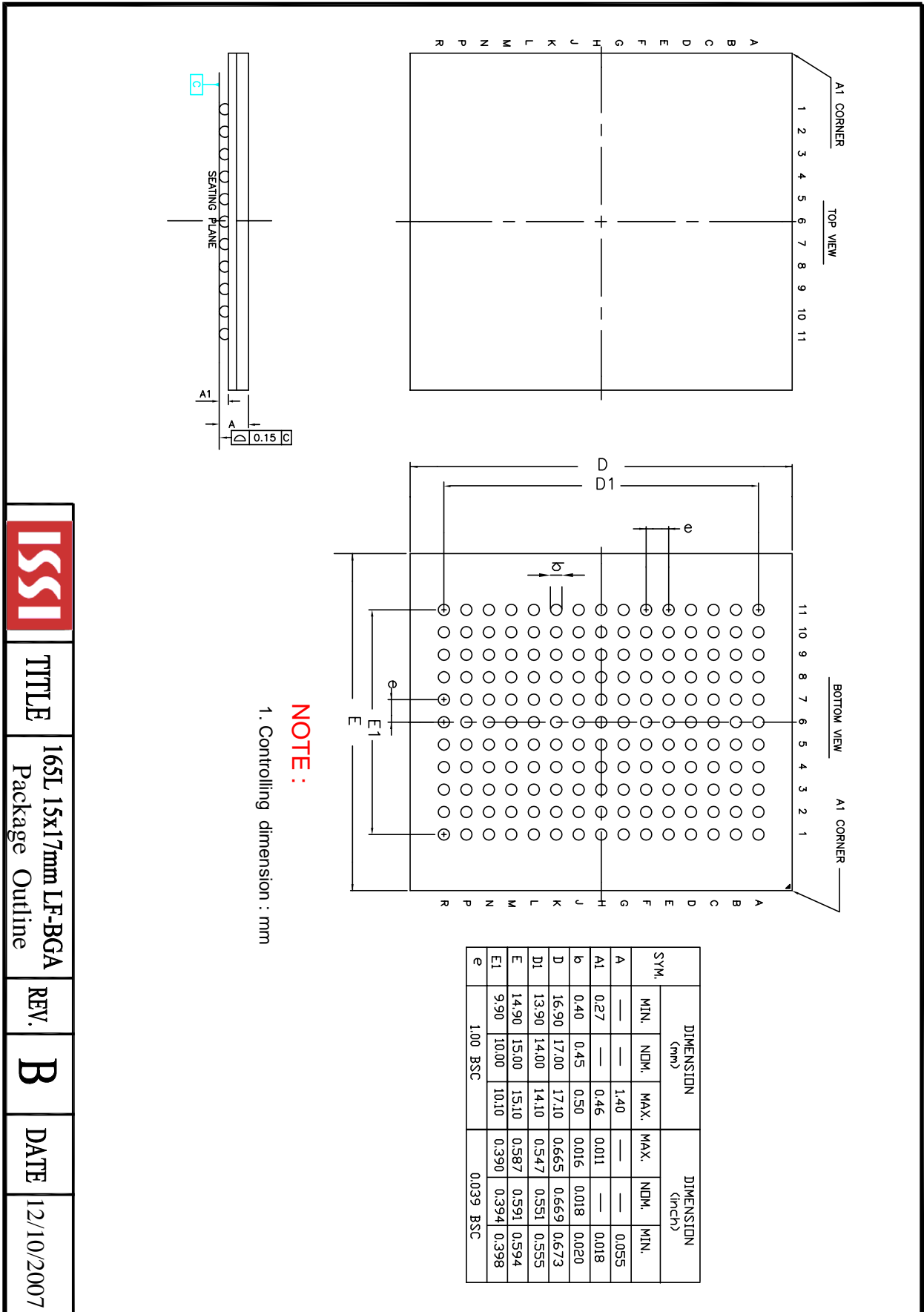

NOTE :
 1. Controlling dimension : mm

SYM.	DIMENSION (mm)			DIMENSION (inches)		
	MIN.	NOM.	MAX.	MAX.	NOM.	MIN.
A	—	—	1.40	—	—	0.055
A1	0.27	—	0.46	0.011	—	0.018
b	0.40	0.45	0.50	0.016	0.018	0.020
D	16.90	17.00	17.10	0.665	0.669	0.673
D1	13.90	14.00	14.10	0.547	0.551	0.555
E	14.90	15.00	15.10	0.587	0.591	0.594
E1	9.90	10.00	10.10	0.390	0.394	0.398
e	1.00 BSC			0.039 BSC		



TITLE

165L 15x17mm LF-BGA
 Package Outline

REV.

B

DATE

12/10/2007

**36 Mb (1M x 36 & 2M x 18)
QUAD (Burst of 2) Synchronous SRAMs**



ORDERING INFORMATION:

Commercial Range: 0°C to +70°C

Speed	Order Part No.	Organization	Package
300 MHz	IS61QDB21M36-300M3	1Mx36	165 BGA
	IS61QDB21M36-300M3L	1Mx36	165 BGA, Lead-free
	IS61QDB22M18-300M3	2Mx18	165 BGA
	IS61QDB22M18-300M3L	2Mx18	165 BGA, Lead-free
250 MHz	IS61QDB21M36-250M3	1Mx36	165 BGA
	IS61QDB21M36-250M3L	1Mx36	165 BGA, Lead-free
	IS61QDB22M18-250M3	2Mx18	165 BGA
	IS61QDB22M18-250M3L	2Mx18	165 BGA, Lead-free

Industrial Range: -40°C to +85°C

Speed	Order Part No.	Organization	Package
300 MHz	IS61QDB21M36-300M3I	1Mx36	165 BGA
	IS61QDB21M36-300M3LI	1Mx36	165 BGA, Lead-free
	IS61QDB22M18-300M3I	2Mx18	165 BGA
	IS61QDB22M18-300M3LI	2Mx18	165 BGA, Lead-free
250 MHz	IS61QDB21M36-250M3I	1Mx36	165 BGA
	IS61QDB21M36-250M3LI	1Mx36	165 BGA, Lead-free
	IS61QDB22M18-250M3I	2Mx18	165 BGA
	IS61QDB22M18-250M3LI	2Mx18	165 BGA, Lead-free

Speed	Top Mark	Order Part No.	Org.	Package
200 MHz	IS61QDB22M18-250M3	U757A-200M3I*	2Mx18	165 BGA
	IS61QDB22M18-250M3L	U757A-200M3LI*	2Mx18	165 BGA, Lead-free
	IS61QDB21M36-250M3	U757D-200M3I*	1Mx36	165 BGA
	IS61QDB21M36-250M3L	U757D-200M3LI*	1Mx36	165 BGA, Lead-free

Note:

* These parts are fully tested to Industrial temperature, even though the top mark is Commercial. By ordering these parts, the customer will receive parts that are tested to the Industrial Temperature of -40°C to +85°C. The speed will be 200MHz at -40°C to +85°C.

Компания «Океан Электроники» предлагает заключение долгосрочных отношений при поставках импортных электронных компонентов на взаимовыгодных условиях!

Наши преимущества:

- Поставка оригинальных импортных электронных компонентов напрямую с производств Америки, Европы и Азии, а так же с крупнейших складов мира;
- Широкая линейка поставок активных и пассивных импортных электронных компонентов (более 30 млн. наименований);
- Поставка сложных, дефицитных, либо снятых с производства позиций;
- Оперативные сроки поставки под заказ (от 5 рабочих дней);
- Экспресс доставка в любую точку России;
- Помощь Конструкторского Отдела и консультации квалифицированных инженеров;
- Техническая поддержка проекта, помощь в подборе аналогов, поставка прототипов;
- Поставка электронных компонентов под контролем ВП;
- Система менеджмента качества сертифицирована по Международному стандарту ISO 9001;
- При необходимости вся продукция военного и аэрокосмического назначения проходит испытания и сертификацию в лаборатории (по согласованию с заказчиком);
- Поставка специализированных компонентов военного и аэрокосмического уровня качества (Xilinx, Altera, Analog Devices, Intersil, Interpoint, Microsemi, Actel, Aeroflex, Peregrine, VPT, Syfer, Eurofarad, Texas Instruments, MS Kennedy, Miteq, Cobham, E2V, MA-COM, Hittite, Mini-Circuits, General Dynamics и др.);

Компания «Океан Электроники» является официальным дистрибьютором и эксклюзивным представителем в России одного из крупнейших производителей разъемов военного и аэрокосмического назначения «JONHON», а так же официальным дистрибьютором и эксклюзивным представителем в России производителя высокотехнологичных и надежных решений для передачи СВЧ сигналов «FORSTAR».



JONHON

«JONHON» (основан в 1970 г.)

Разъемы специального, военного и аэрокосмического назначения:

(Применяются в военной, авиационной, аэрокосмической, морской, железнодорожной, горно- и нефтедобывающей отраслях промышленности)

«FORSTAR» (основан в 1998 г.)

ВЧ соединители, коаксиальные кабели, кабельные сборки и микроволновые компоненты:

(Применяются в телекоммуникациях гражданского и специального назначения, в средствах связи, РЛС, а так же военной, авиационной и аэрокосмической отраслях промышленности).



Телефон: 8 (812) 309-75-97 (многоканальный)

Факс: 8 (812) 320-03-32

Электронная почта: ocean@oceanchips.ru

Web: <http://oceanchips.ru/>

Адрес: 198099, г. Санкт-Петербург, ул. Калинина, д. 2, корп. 4, лит. А