

25 W mono BTL class-D audio amplifier

Datasheet - production data

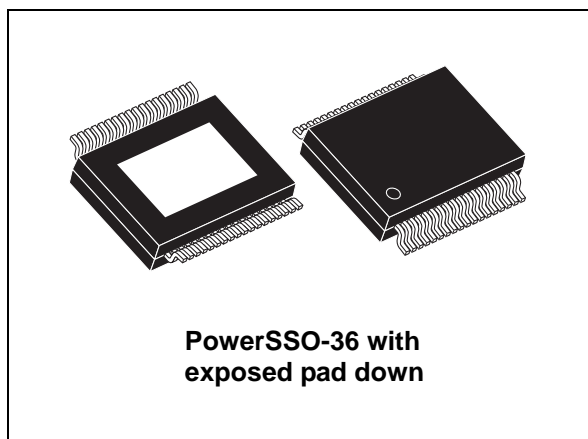

Description

The TDA7491MV is a mono BTL class-D audio amplifier with single power supply designed for LCD TVs and monitors.

Thanks to the high efficiency and an exposed-pad-down (EPD) package no heatsink is required.

Furthermore, the filterless operation allows a reduction in the external component count.

The TDA7491MV is pin to pin compatible with the TDA7491P, TDA7491LP and TDA7491HV for the left channel.

Features

- 20 W continuous output power: $R_L = 8 \Omega$, THD = 10% at $V_{CC} = 18 V$
- 25 W continuous output power: $R_L = 6 \Omega$, THD = 10% at $V_{CC} = 16 V$
- Wide range single supply operation (5 V - 18 V)
- High efficiency ($\eta = 90\%$)
- Four selectable, fixed gain settings of nominally 20 dB, 26 dB, 30 dB and 32 dB
- Differential inputs minimize common-mode noise
- Filterless operation
- No 'pop' at turn-on/off
- Standby and mute features
- Short-circuit protection
- Thermal overload protection
- Externally synchronizable

Table 1. Device summary

Order code	Operating temp. range	Package	Packaging
TDA7491MV13TR	- 40 to 85 °C	PowerSSO-36 EPD	Tape and reel

Contents

- 1 Device block diagram 5**
- 2 Pin description 6**
 - 2.1 Pin out 6
 - 2.2 Pin list 7
- 3 Electrical specifications 8**
 - 3.1 Absolute maximum ratings 8
 - 3.2 Thermal data 8
 - 3.3 Electrical specifications 8
- 4 Characterization curves 11**
 - 4.1 Test board 16
- 5 Package mechanical data 17**
- 6 Applications circuit 19**
 - 6.1 Compatibility with TDA7491 stereo BTL family 19
- 7 Application information 20**
 - 7.1 Mode selection 20
 - 7.2 Gain setting 21
 - 7.3 Input resistance and capacitance 21
 - 7.4 Internal and external clocks 22
 - 7.4.1 Master mode (internal clock) 22
 - 7.4.2 Slave mode (external clock) 22
 - 7.5 Filterless modulation 23
 - 7.6 Output low-pass filter 24
 - 7.7 Protection function 25
 - 7.8 Diagnostic output 25
 - 7.9 Heatsink requirements 26
- 8 Revision history 27**

List of tables

Table 1.	Device summary	1
Table 2.	Pin description list	7
Table 3.	Absolute maximum ratings	8
Table 4.	Thermal data	8
Table 5.	Electrical specifications	8
Table 6.	PowerSSO-36 EPD dimensions	18
Table 7.	Mode settings	20
Table 8.	Gain settings	21
Table 9.	How to set up SYNCLK	22
Table 10.	Document revision history	27

List of figures

Figure 1.	Internal block diagram	5
Figure 2.	Pin connection (top view, PCB view)	6
Figure 3.	Output power vs. supply voltage	11
Figure 4.	THD vs output power (1 kHz)	11
Figure 5.	THD vs. output power (100 Hz)	12
Figure 6.	THD vs. frequency	12
Figure 7.	Frequency response	12
Figure 8.	FFT (0 dB)	13
Figure 9.	FFT (-60 dB)	13
Figure 10.	Closed-loop gain vs. frequency	13
Figure 11.	Power dissipation and efficiency vs. output power	14
Figure 12.	Attenuation vs. mute voltage	14
Figure 13.	Current consumption vs. voltage on pin STBY	14
Figure 14.	Attenuation vs. voltage on pin STBY	15
Figure 15.	Power supply rejection ratio vs. frequency	15
Figure 16.	Test board (TDA7491HV) layout	16
Figure 17.	PowerSSO-36 EPD outline drawing	17
Figure 18.	Applications circuit for class-D amplifier	19
Figure 19.	Standby and mute circuits	20
Figure 20.	Turn-on/off sequence for minimizing speaker “pop”	20
Figure 21.	Device input circuit and frequency response	21
Figure 22.	Master and slave connection	22
Figure 23.	Unipolar PWM output	23
Figure 24.	Typical LC filter for a 8 Ω speaker	24
Figure 25.	Typical LC filter for a 4 Ω speaker	24
Figure 26.	Behavior of pin DIAG for various protection conditions	25
Figure 27.	Power derating curves for PCB used as heatsink	26

1 Device block diagram

Figure 1 shows the block diagram of the TDA7491MV.

Figure 1. Internal block diagram

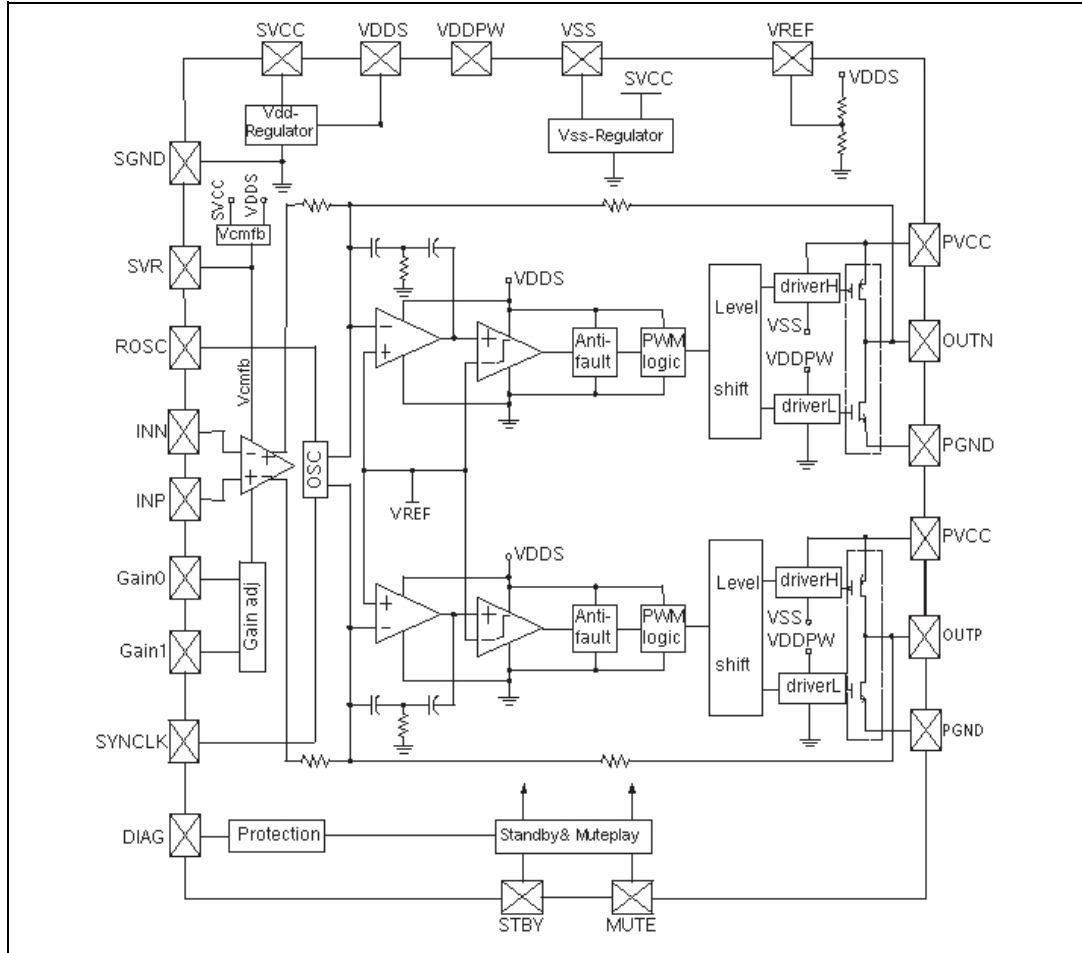

2 Pin description

2.1 Pin out

Figure 2. Pin connection (top view, PCB view)

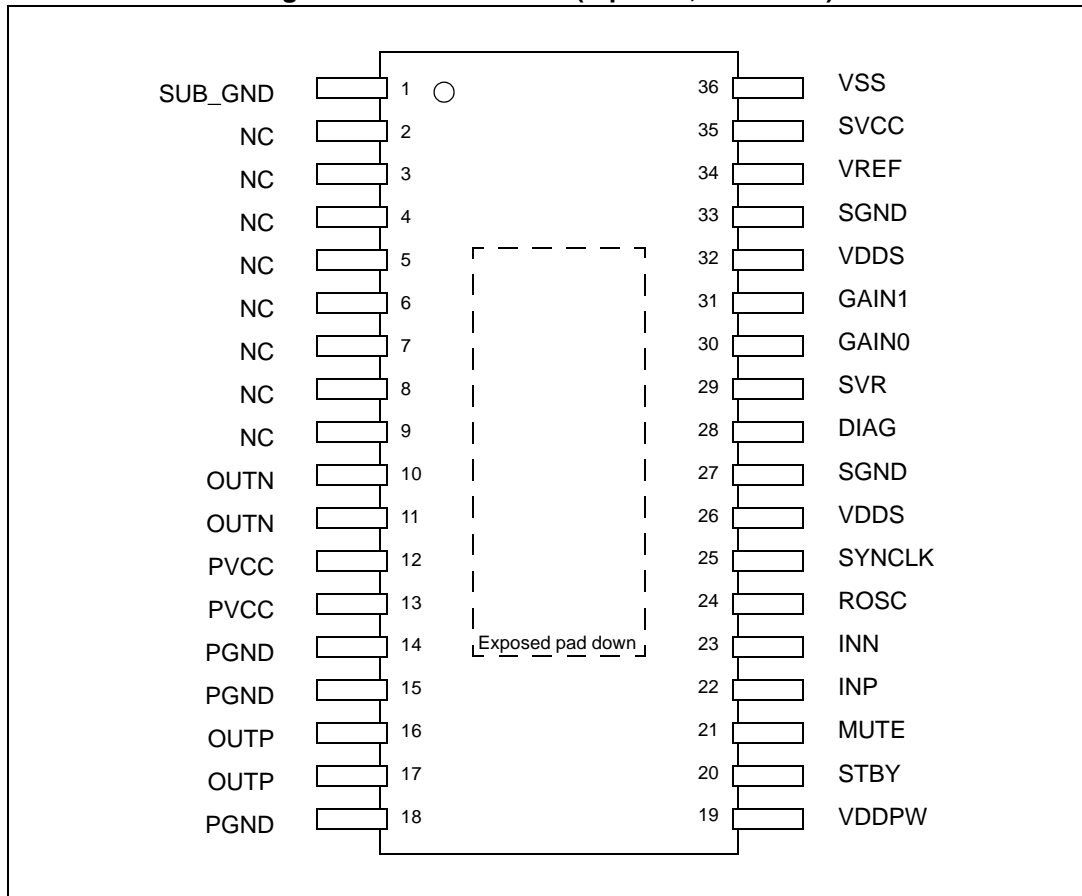

2.2 Pin list

Table 2. Pin description list

Pin n°	Name	Type	Description
1	SUB_GND	POWER	Connect to the frame
2, 3	NC	-	No internal connection
4, 5	NC	-	No internal connection
6, 7	NC	-	No internal connection
8, 9	NC	-	No internal connection
10,11	OUTN	OUT	Negative PWM output
12,13	PVCC	POWER	Power supply
14,15	PGND	POWER	Power stage ground
16,17	OUTP	OUT	Positive PWM output
18	PGND	POWER	Power stage ground
19	VDDPW	OUT	3.3 V (nominal) regulator output referred to ground for power stage
20	STBY	INPUT	Standby mode control
21	MUTE	INPUT	Mute mode control
22	INP	INPUT	Positive differential input
23	INN	INPUT	Negative differential input
24	ROSC	OUT	Master oscillator frequency-setting pin
25	SYNCLCK	IN/OUT	Clock in/out for external oscillator
26	VDDS	OUT	3.3 V (nominal) regulator output referred to ground for signal blocks
27	SGND	POWER	Signal ground
28	DIAG	OUT	Open-drain diagnostic output
29	SVR	OUT	Supply voltage rejection
30	GAIN0	INPUT	Gain setting input 1
31	GAIN1	INPUT	Gain setting input 2
32	VDDS	POWER	To be connected to VDDS (pin 26)
33	SGND	POWER	Signal ground
34	VREF	OUT	Half VDDS (nominal) referred to ground
35	SVCC	POWER	Signal power supply
36	VSS	OUT	3.3 V (nominal) regulator output referred to power supply

3 Electrical specifications

3.1 Absolute maximum ratings

Table 3. Absolute maximum ratings

Symbol	Parameter	Value	Unit
V_{CC}	DC supply voltage for pins PVCCA, PVCCB, SVCC	24	V
T_{op}	Operating temperature	-40 to 85	°C
T_j	Junction temperature	-40 to 150	°C
T_{stg}	Storage temperature	-40 to 150	°C

3.2 Thermal data

Table 4. Thermal data

Symbol	Parameter	Min.	Typ.	Max.	Unit
$R_{th\ j-case}$	Thermal resistance, junction to case	-	2	3	°C/W
$R_{th\ j-amb}$	Thermal resistance, junction to ambient (mounted on recommended PCB) ⁽¹⁾	-	24	-	

1. FR4 with vias to copper area of 9 cm² (see also [Section 7.9: Heatsink requirements on page 26](#)).

3.3 Electrical specifications

Unless otherwise stated, the results in [Table 5](#) below are given for the conditions:

$V_{CC} = 18\text{ V}$, R_L (load) = 8 Ω , $R_{OSC} = R3 = 39\text{ k}\Omega$, $C8 = 100\text{ nF}$, $f = 1\text{ kHz}$, $G_V = 20\text{ dB}$, and $T_{amb} = 25\text{ °C}$.

Table 5. Electrical specifications

Symbol	Parameter	Condition	Min.	Typ.	Max.	Unit
V_{CC}	Supply voltage for pins PVCC, SVCC	-	5	-	18	V
I_q	Total quiescent	Without LC filter	-	26	35	mA
I_{qSTBY}	Quiescent current in standby	-	-	2.5	5.0	μA
V_{OS}	Output offset voltage	Play mode	-150	-	150	mV
V_{OS}	Output offset voltage	Mute mode	-60	-	60	mV
I_{OCP}	Overcurrent protection threshold	$R_L = 0\ \Omega$	3	5	-	A
T_j	Junction temperature at thermal shutdown	-	-	150	-	°C
R_i	Input resistance	Differential input	55	60	-	k Ω
V_{OVP}	Overvoltage protection threshold	-	19	21	-	V

Table 5. Electrical specifications (continued)

Symbol	Parameter	Condition	Min.	Typ.	Max.	Unit
V_{UVP}	Undervoltage protection threshold	-	-	-	4	V
R_{dsON}	Power transistor on resistance	High side	-	0.2	-	Ω
		Low side	-	0.2	-	
P_o	Output power	THD = 10%	-	20	-	W
		THD = 1%	-	16	-	
P_o	Output power	$R_L = 8 \Omega$, THD = 10% $V_{\text{CC}} = 12 \text{ V}$	-	9.5	-	W
		$R_L = 8 \Omega$, THD = 1% $V_{\text{CC}} = 12 \text{ V}$	-	7.2	-	
P_o	Output power	$R_L = 6 \Omega$, THD = 10% $V_{\text{CC}} = 16 \text{ V}$	-	20	-	W
		$R_L = 6 \Omega$, THD = 1% $V_{\text{CC}} = 16 \text{ V}$	-	16	-	
P_D	Dissipated power	$P_o = 20 \text{ W}$ THD = 10%	-	2.0	-	W
η	Efficiency	$P_o = 20 \text{ W}$	80	90	-	%
THD	Total harmonic distortion	$P_o = 1 \text{ W}$	-	0.1	0.2	%
G_V	Closed loop gain	GAIN0 = L, GAIN1 = L	18	20	22	dB
		GAIN0 = L, GAIN1 = H	24	26	28	
		GAIN0 = H, GAIN1 = L	28	30	32	
		GAIN0 = H, GAIN1 = H	30	32	34	
ΔG_V	Gain matching	-	-1	-	1	dB
eN	Total input noise	A Curve, $G_V = 20 \text{ dB}$	-	20	-	μV
		$f = 22 \text{ Hz to } 22 \text{ kHz}$	-	25	35	
SVRR	Supply voltage rejection ratio	$f_r = 100 \text{ Hz}$, $V_r = 0.5 \text{ V}$, $C_{\text{SVR}} = 10 \mu\text{F}$	40	50	-	dB
T_r , T_f	Rise and fall times	-	-	50	-	ns
f_{SW}	Switching frequency	Internal oscillator	290	310	330	kHz
f_{SWR}	Output switching frequency	With internal oscillator ⁽¹⁾	250	-	-	kHz
		With external oscillator ⁽²⁾	250	-	-	
V_{inH}	Digital input high (H)	-	2.3	-	-	V
V_{inL}	Digital input low (L)		-	-	0.8	
A_{MUTE}	Mute attenuation	$V_{\text{MUTE}} = 1 \text{ V}$	60	80	-	dB

Table 5. Electrical specifications (continued)

Symbol	Parameter	Condition	Min.	Typ.	Max.	Unit
Function mode	Standby, mute and play modes	$V_{STBY} < 0.5 \text{ V}$, $V_{MUTE} = X$	Standby			-
		$V_{STBY} > 2.5 \text{ V}$, $V_{MUTE} < 0.8 \text{ V}$	Mute			-
		$V_{STBY} > 2.5 \text{ V}$, $V_{MUTE} > 2.5 \text{ V}$	Play			-

- $f_{SW} = 10^6 / ((16 * R_{OSC} + 182) * 4)$ kHz, $f_{SYNCLK} = 2 * f_{SW}$ with $R3 = 39 \text{ k}\Omega$ (see [Figure 18](#).)
- $f_{SW} = f_{SYNCLK} / 2$ with the frequency of the external oscillator.

4 Characterization curves

The following characterization curves were made using the TDA7491MV demo board. The LC filter for the 8-Ω load uses components of 33 μH and 220 nF.

All other test conditions are given along side the corresponding curves.

Figure 3. Output power vs. supply voltage

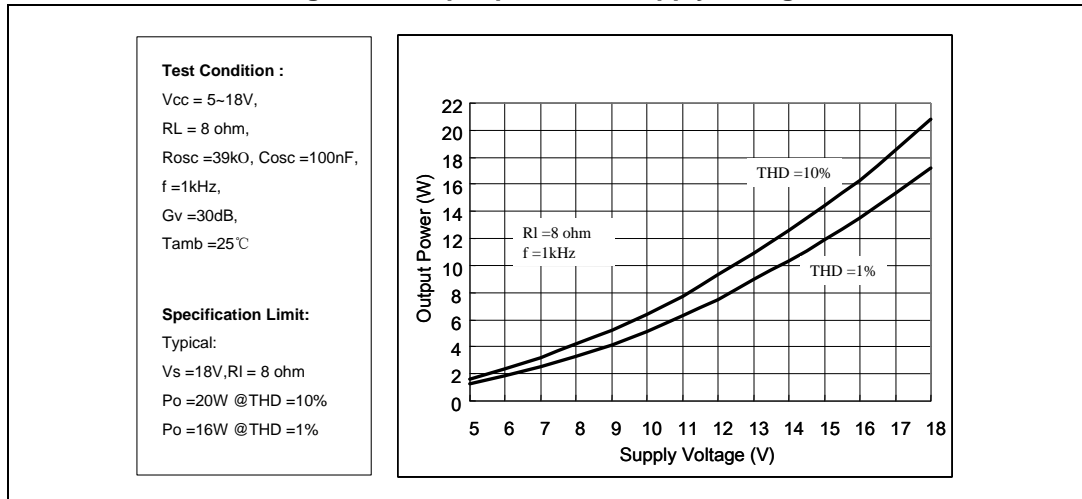

Figure 4. THD vs output power (1 kHz)

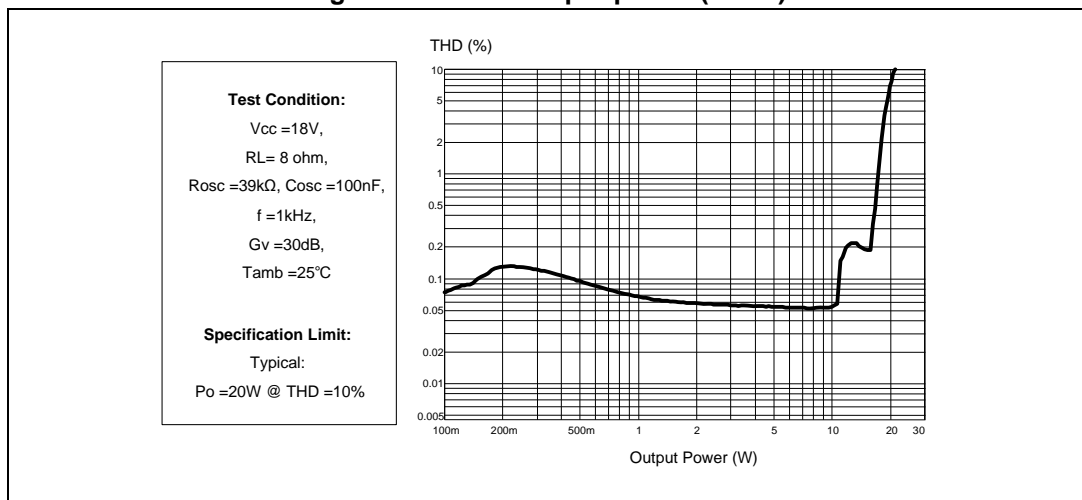

Figure 5. THD vs. output power (100 Hz)

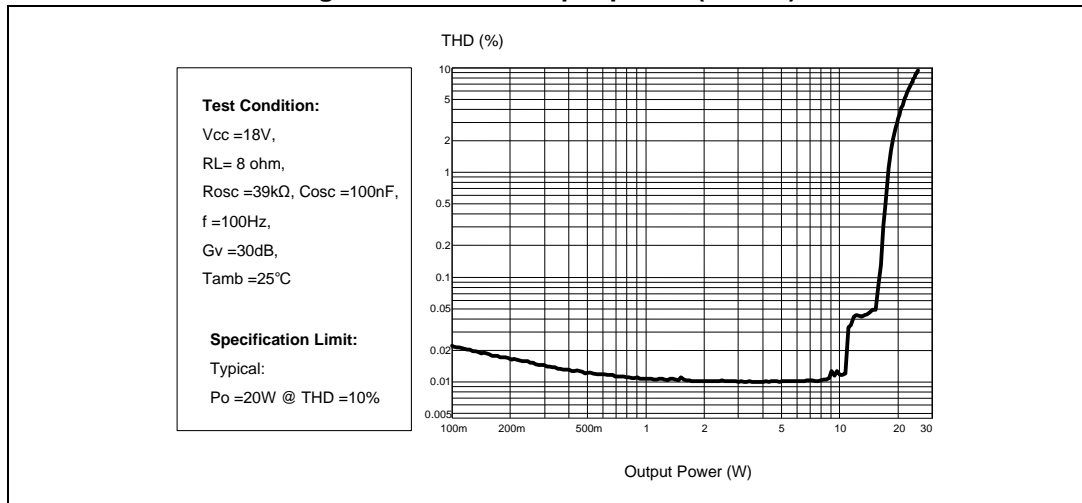

Figure 6. THD vs. frequency

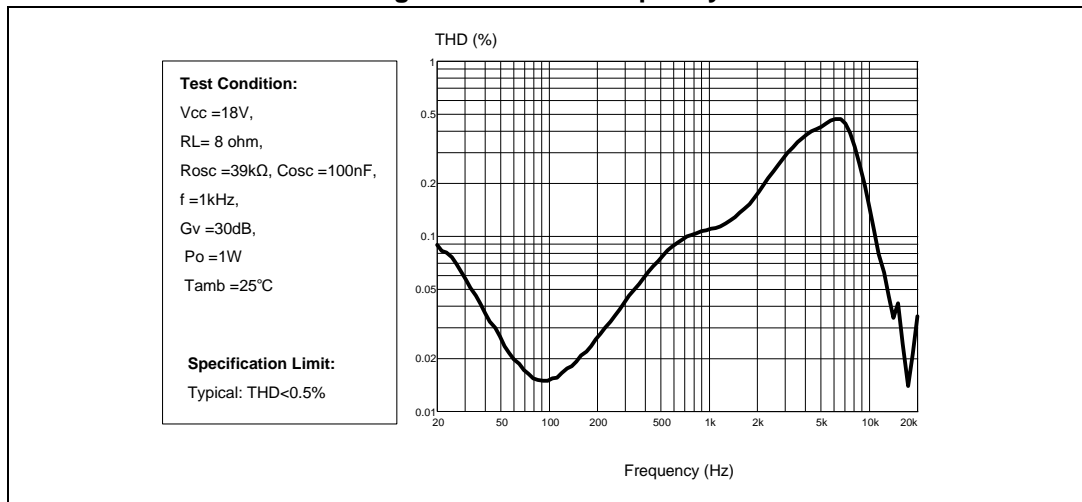

Figure 7. Frequency response

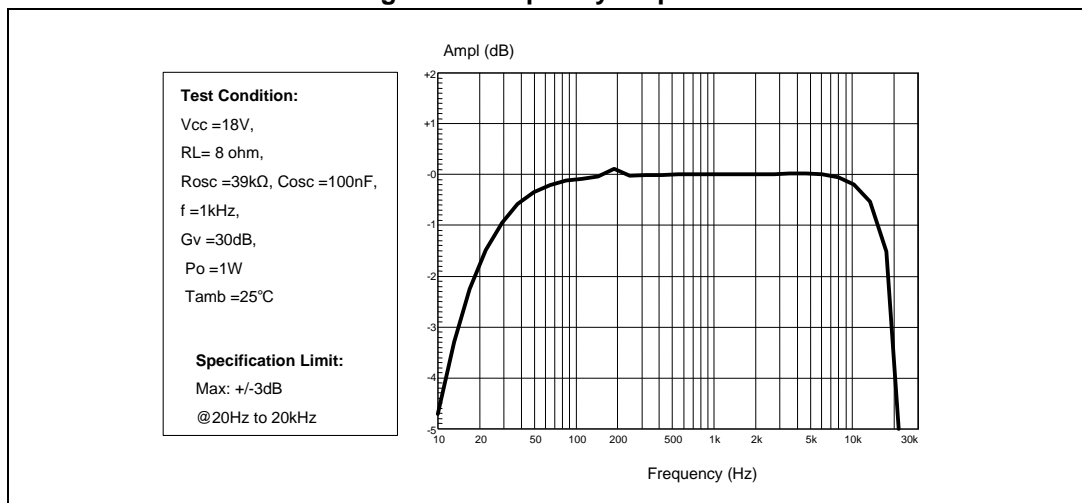

Figure 8. FFT (0 dB)

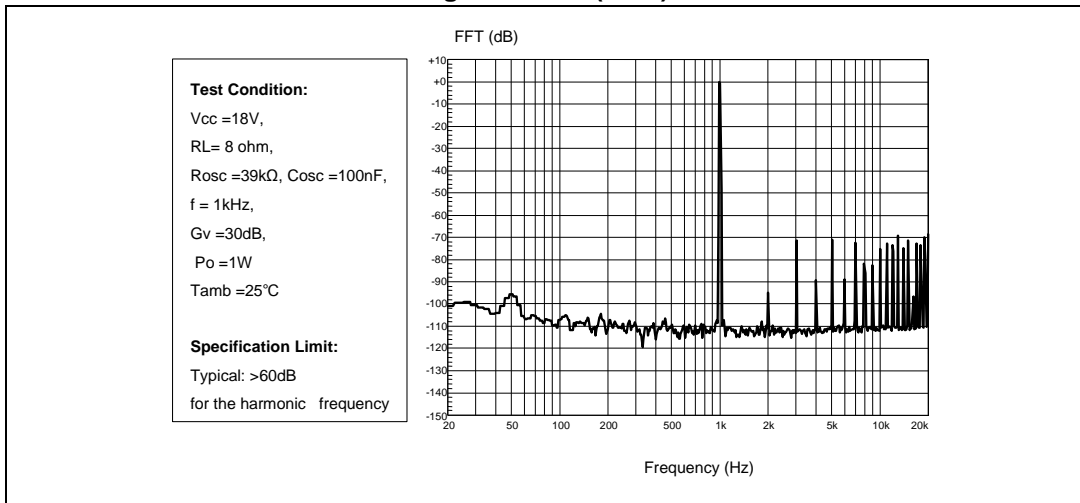

Figure 9. FFT (-60 dB)

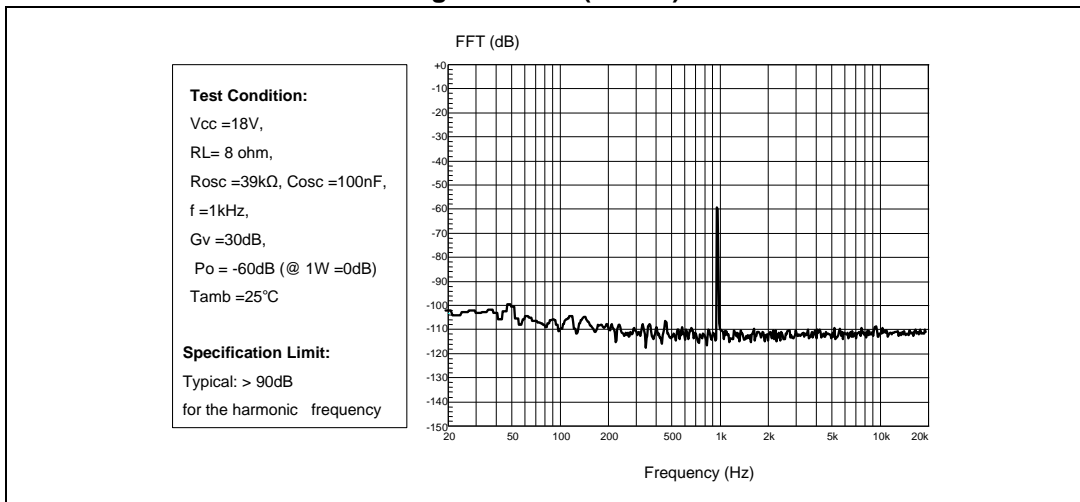

Figure 10. Closed-loop gain vs. frequency

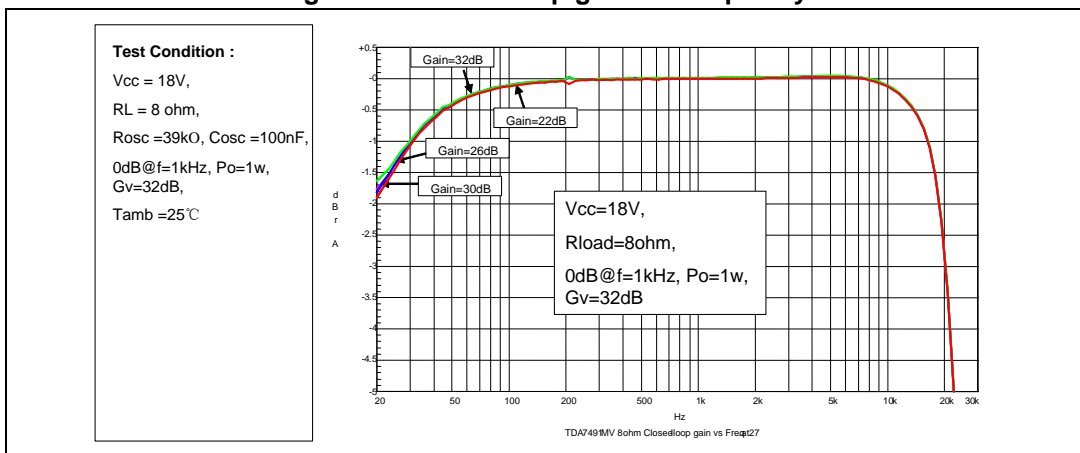

Figure 11. Power dissipation and efficiency vs. output power

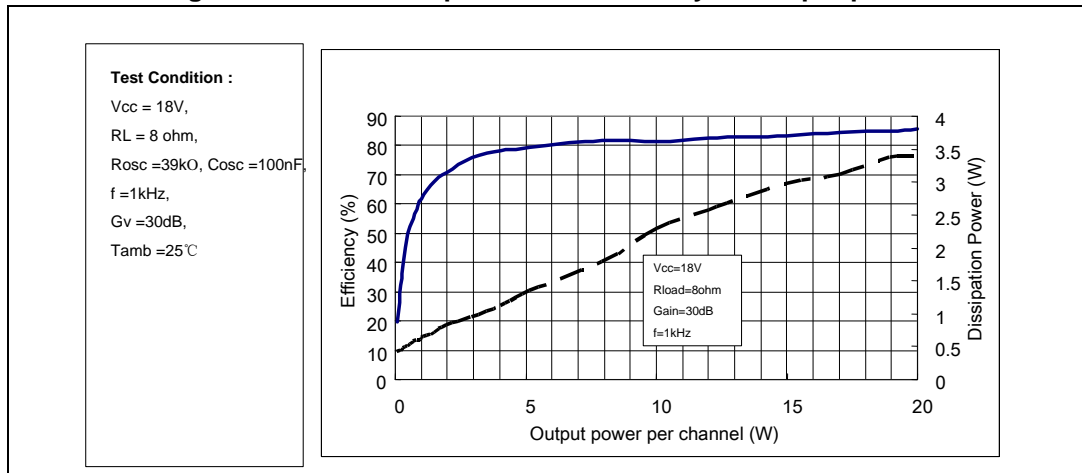

Figure 12. Attenuation vs. mute voltage

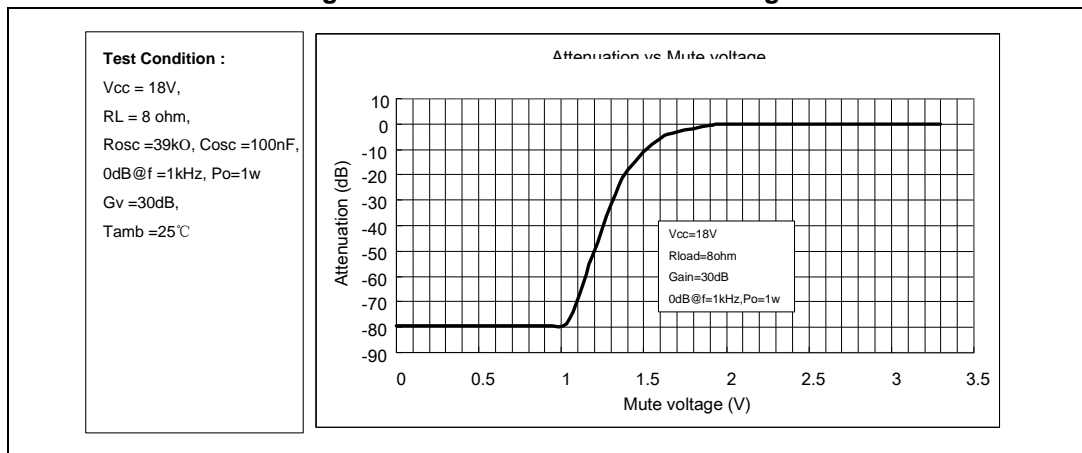

Figure 13. Current consumption vs. voltage on pin STBY

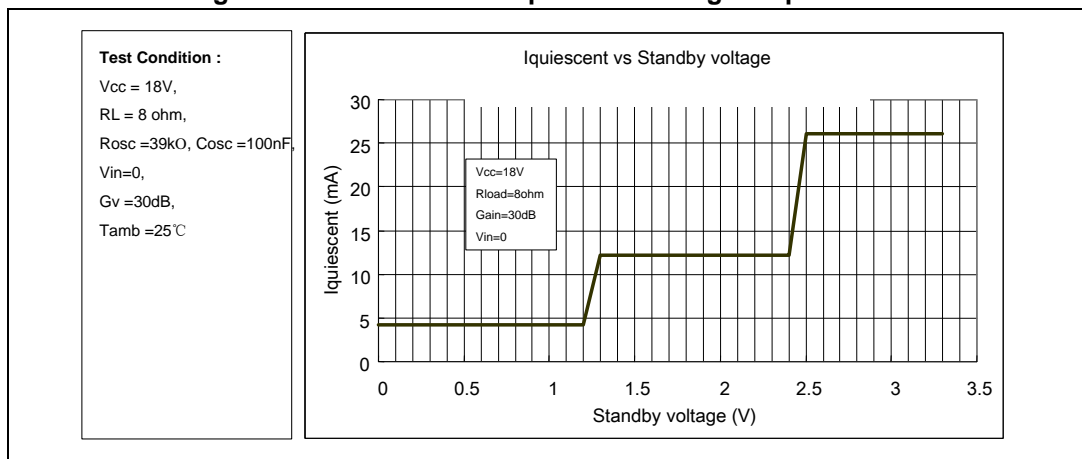

Figure 14. Attenuation vs. voltage on pin STBY

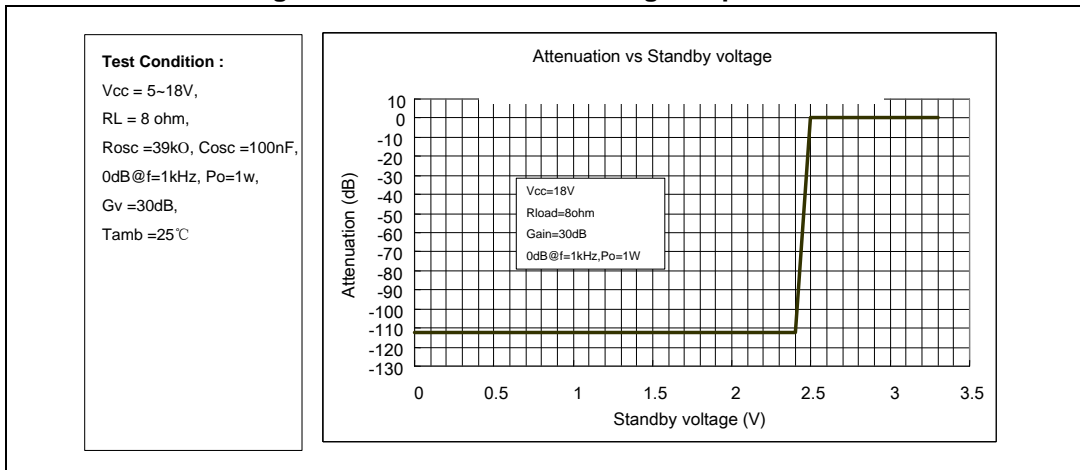
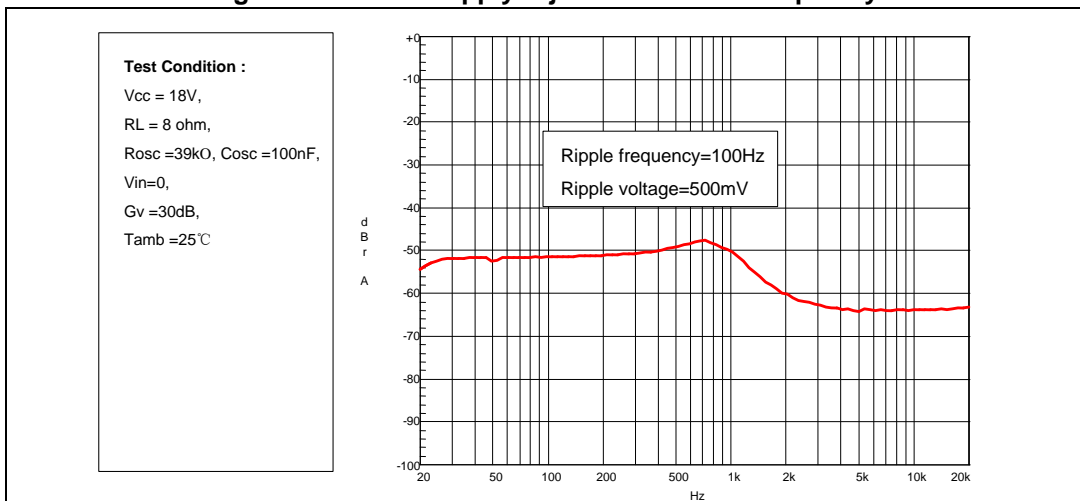

Figure 15. Power supply rejection ratio vs. frequency



5 Package mechanical data

The TDA7491MV comes in a 36-pin PowerSSO package with exposed pad down.

[Figure 17](#) below shows the package outline and [Table 6](#) gives the dimensions.

Figure 17. PowerSSO-36 EPD outline drawing

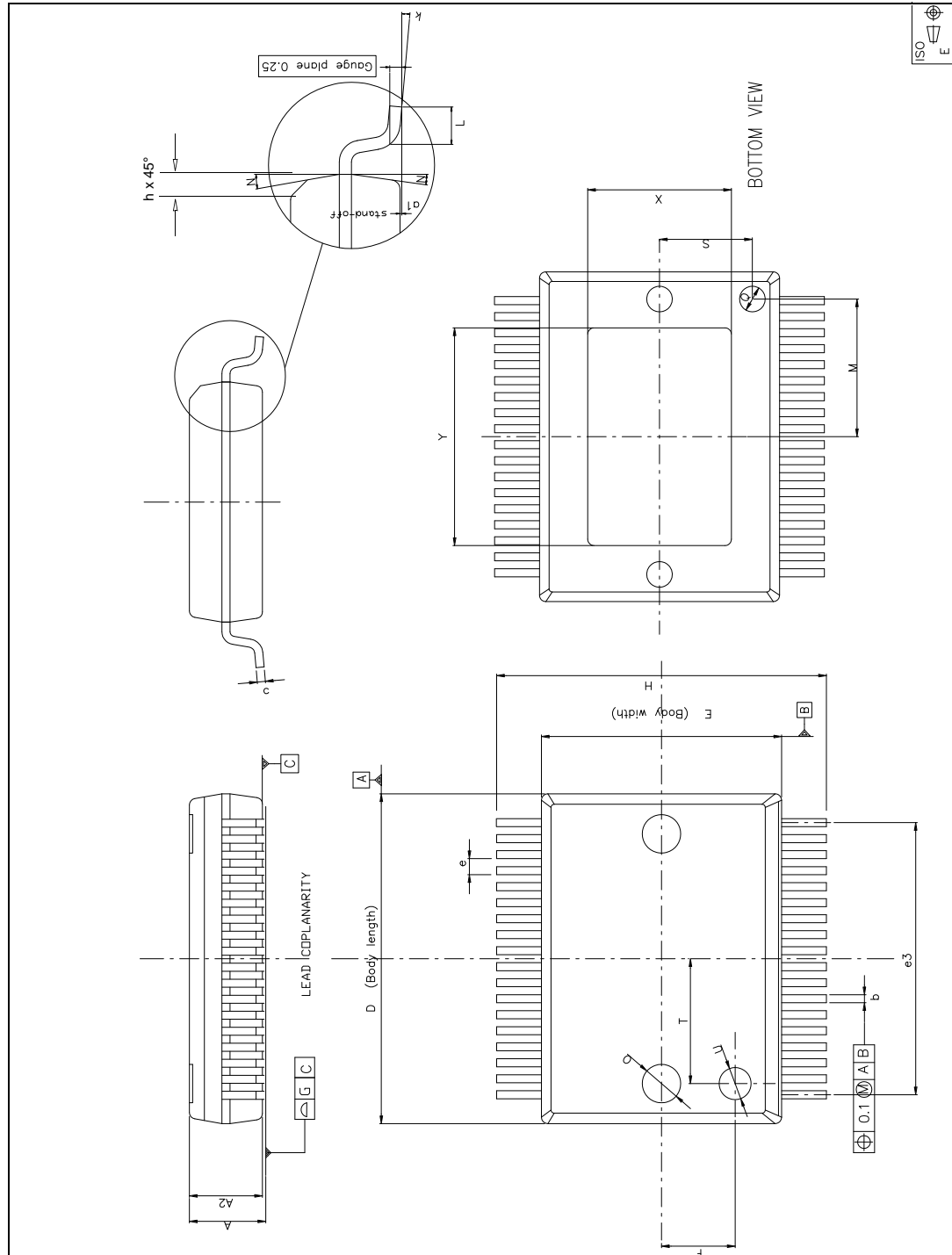

Table 6. PowerSSO-36 EPD dimensions

Symbol	Dimensions in mm			Dimensions in inches		
	Min.	Typ.	Max.	Min.	Typ.	Max.
A	2.15	-	2.47	0.085	-	0.097
A2	2.15	-	2.40	0.085	-	0.094
a1	0.00	-	0.10	0.000	-	0.004
b	0.18	-	0.36	0.007	-	0.014
c	0.23	-	0.32	0.009	-	0.013
D	10.10	-	10.50	0.398	-	0.413
E	7.40	-	7.60	0.291	-	0.299
e	-	0.5	-	-	0.020	-
e3	-	8.5	-	-	0.335	-
F	-	2.3	-	-	0.091	-
G	-	-	0.10	-	-	0.004
H	10.10	-	10.50	0.398	-	0.413
h	-	-	0.40	-	-	0.016
k	0	-	8 degrees	0	-	8 degrees
L	0.60	-	1.00	0.024	-	0.039
M	-	4.30	-	-	0.169	-
N	-	-	10 degrees	-	-	10 degrees
O	-	1.20	-	-	0.047	-
Q	-	0.80	-	-	0.031	-
S	-	2.90	-	-	0.114	-
T	-	3.65	-	-	0.144	-
U	-	1.00	-	-	0.039	-
X	4.10	-	4.70	0.161	-	0.185
Y	6.50	-	7.10	0.256	-	0.280

In order to meet environmental requirements, ST offers these devices in different grades of ECOPACK[®] packages, depending on their level of environmental compliance. ECOPACK[®] specifications, grade definitions and product status are available at: www.st.com. ECOPACK[®] is an ST trademark.

6 Applications circuit

Figure 18. Applications circuit for class-D amplifier

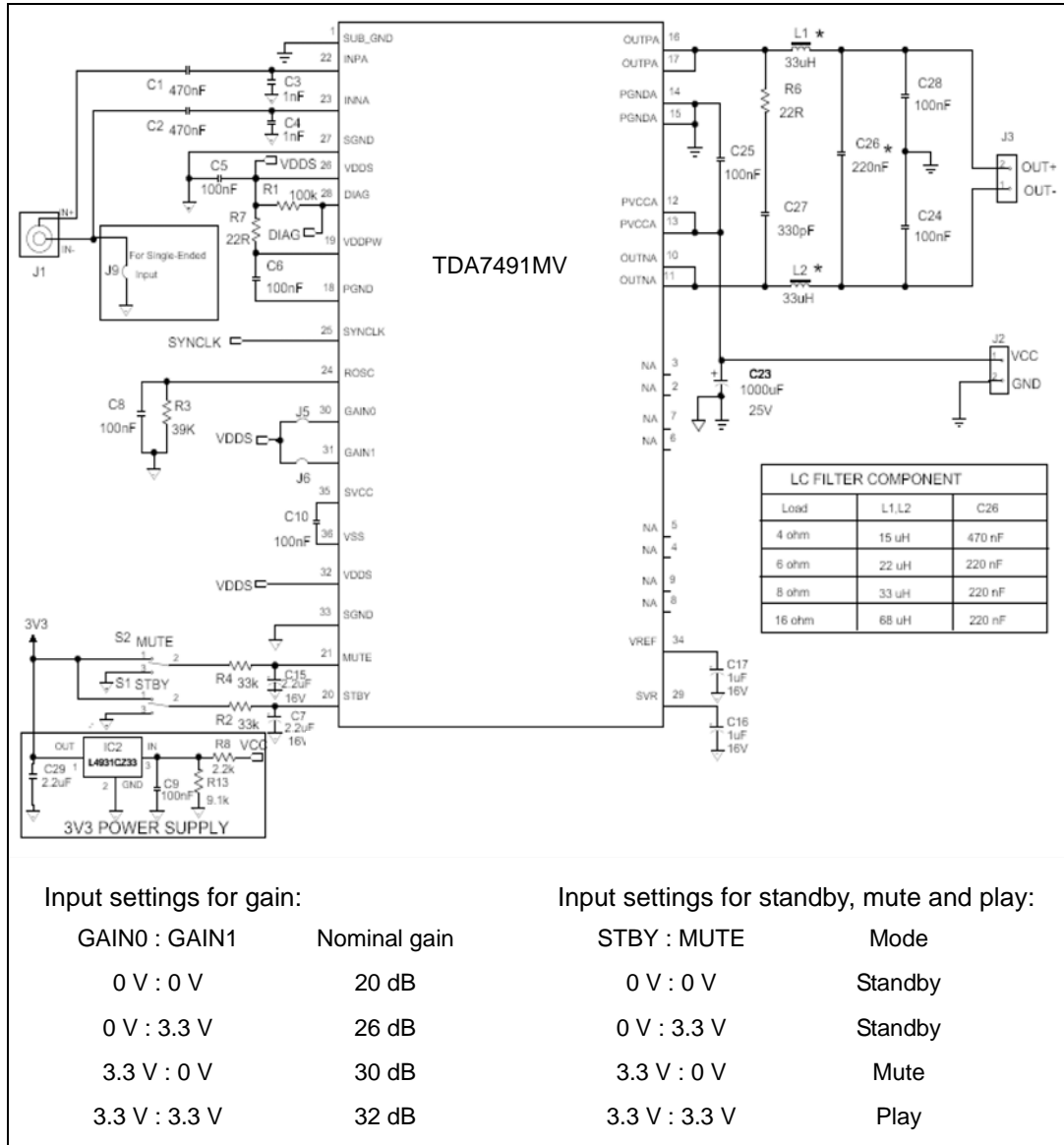

6.1 Compatibility with TDA7491 stereo BTL family

TDA7491MV mono BTL analog class-D amplifier is derived from the TDA7491 stereo analog class-D BTL family. TDA7491MV has only the left channel of the stereo BTL family.

In order to guarantee the pin to pin compatibility when moving the application from stereo to mono, it is necessary to connect the right channel inputs (pins 32 and 33 of TDA7491 BTL family) to V_{CC} and GND, that is, pin 32 to VDDA and pin 33 to SGND.

7 Application information

7.1 Mode selection

The three operating modes of the TDA7491MV are set by the two inputs STBY (pin 20) and MUTE (pin 21).

- Standby mode: all circuits are turned off, very low current consumption.
- Mute mode: inputs are connected to ground and the positive and negative PWM outputs are at 50% duty cycle.
- Play mode: the amplifiers are active.

The protection functions of the TDA7491MV are realized by pulling down the voltages of the STBY and MUTE inputs shown in *Figure 19*. The input current of the corresponding pins must be limited to 200 μ A.

Table 7. Mode settings

Mode Selection	STBY	MUTE
Standby	L ⁽¹⁾	X (don't care)
Mute	H ⁽¹⁾	L
Play	H	H

1. Drive levels defined in *Table 5: Electrical specifications on page 8*

Figure 19. Standby and mute circuits

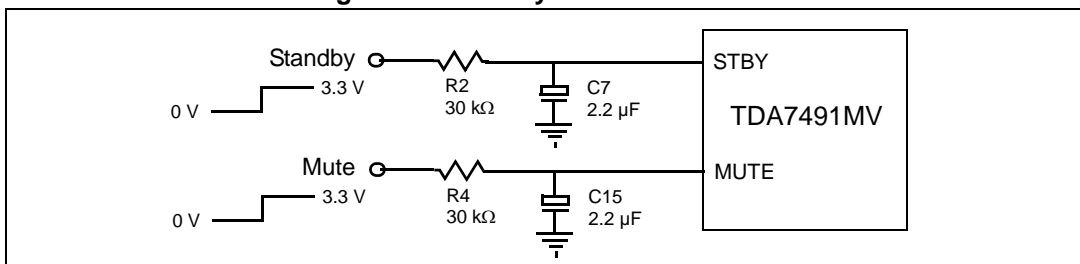
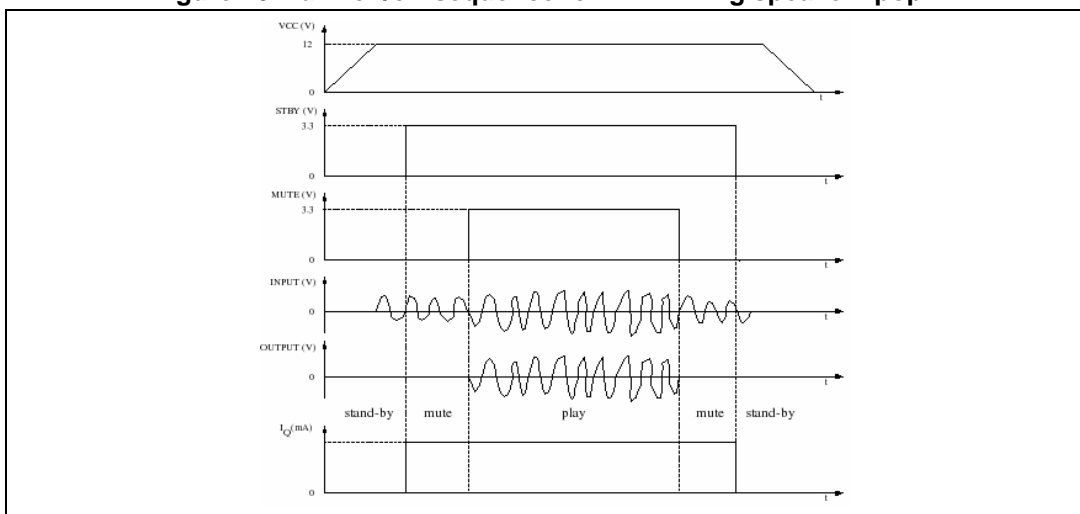

Figure 20. Turn-on/off sequence for minimizing speaker “pop”



7.2 Gain setting

The gain of the TDA7491MV is set by the two inputs, GAIN0 (pin 30) and GAIN1 (pin 31). Internally, the gain is set by changing the feedback resistors of the amplifier.

Table 8. Gain settings

GAIN0	GAIN1	Nominal gain, G_v (dB)
0	0	20
0	1	26
1	0	30
1	1	32

7.3 Input resistance and capacitance

The input impedance is set by an internal resistor $R_i = 60\text{ k}\Omega$ (typical). An input capacitor (C_i) is required to couple the AC input signal.

The equivalent circuit and frequency response of the input components are shown in [Figure 21](#). For $C_i = 220\text{ nF}$ the high-pass filter cut-off frequency is below 20 Hz:

$$f_c = 1 / (2 * \pi * R_i * C_i)$$

Figure 21. Device input circuit and frequency response

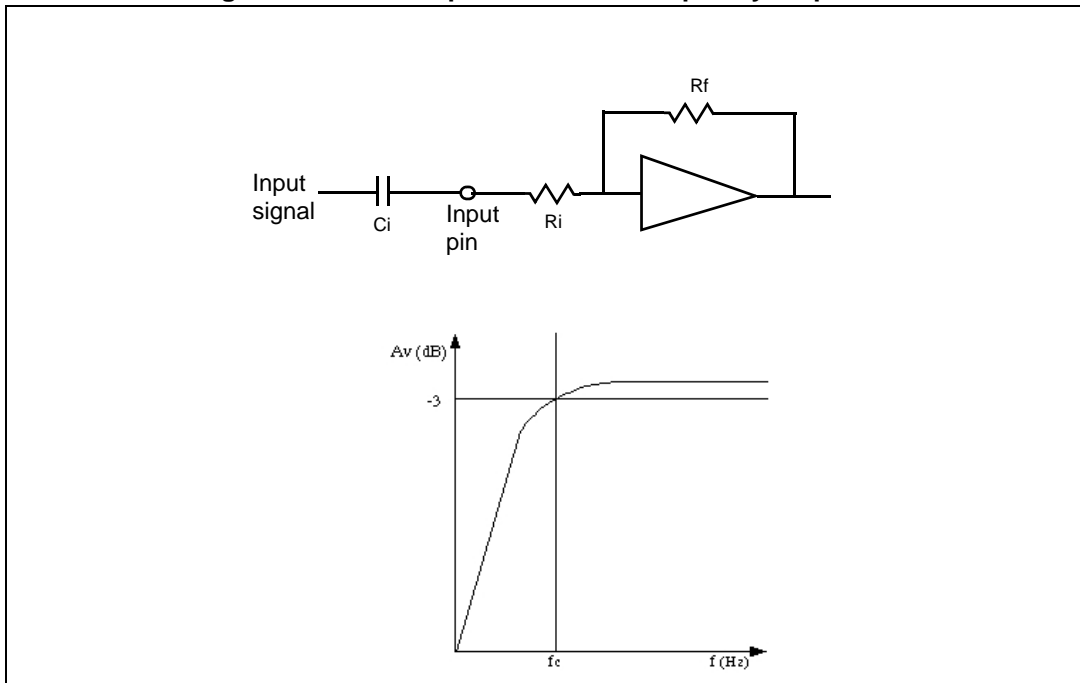

7.4 Internal and external clocks

The clock of the class-D amplifier can be generated internally or can be driven by an external source.

If two or more class-D amplifiers are used in the same system, it is recommended that all devices operate at the same clock frequency. This can be implemented by using one TDA7491MV as master clock, while the other devices are in slave mode (that is, externally clocked). The clock interconnect is via pin SYNCLK of each device. As explained below, SYNCLK is an output in master mode and an input in slave mode.

7.4.1 Master mode (internal clock)

Using the internal oscillator, the output switching frequency, f_{SW} , is controlled by the resistor, R_{OSC} , connected to pin ROSC:

$$f_{SW} = 10^6 / ((16 * R_{OSC} + 182) * 4) \text{ kHz}$$

where R_{OSC} is in $k\Omega$.

In master mode, pin SYNCLK is used as a clock output pin, whose frequency is:

$$f_{SYNCLK} = 2 * f_{SW}$$

For master mode to operate correctly then resistor R_{OSC} must be less than $60 k\Omega$ as given below in [Table 9](#).

7.4.2 Slave mode (external clock)

In order to accept an external clock input the pin ROSC must be left open, that is, floating. This forces pin SYNCLK to be internally configured as an input as given in [Table 9](#).

The output switching frequency of the slave devices is:

$$f_{SW} = f_{SYNCLK} / 2$$

Table 9. How to set up SYNCLK

Mode	ROSC	SYNCLK
Master	$R_{OSC} < 60 k\Omega$	Output
Slave	Floating (not connected)	Input

Figure 22. Master and slave connection

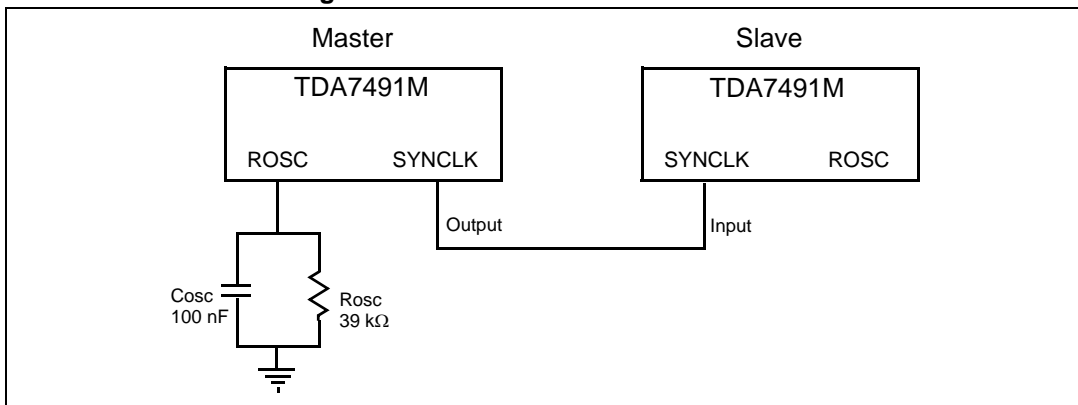

7.5 Filterless modulation

The output modulation scheme of the BTL is called unipolar pulse width modulation (PWM). The differential output voltages change between 0 V and $+V_{CC}$ and between 0 V and $-V_{CC}$. This is in contrast to the traditional bipolar PWM outputs which change between $+V_{CC}$ and $-V_{CC}$.

An advantage of this scheme is that it effectively doubles the switching frequency of the differential output waveform. The OUTP and OUTN are in the same phase when the input is zero, then the switching current is low and the loss in the load is small. In practice, a short delay is introduced between these two outputs in order to avoid the BTL output switching at the same time.

TDA7491MV can be used without a filter before the speaker, because the frequency of the TDA7491MV output is beyond the audio frequency, the audio signal can be recovered by the inherent inductance of the speaker and natural filter of the human ear.

Figure 23. Unipolar PWM output

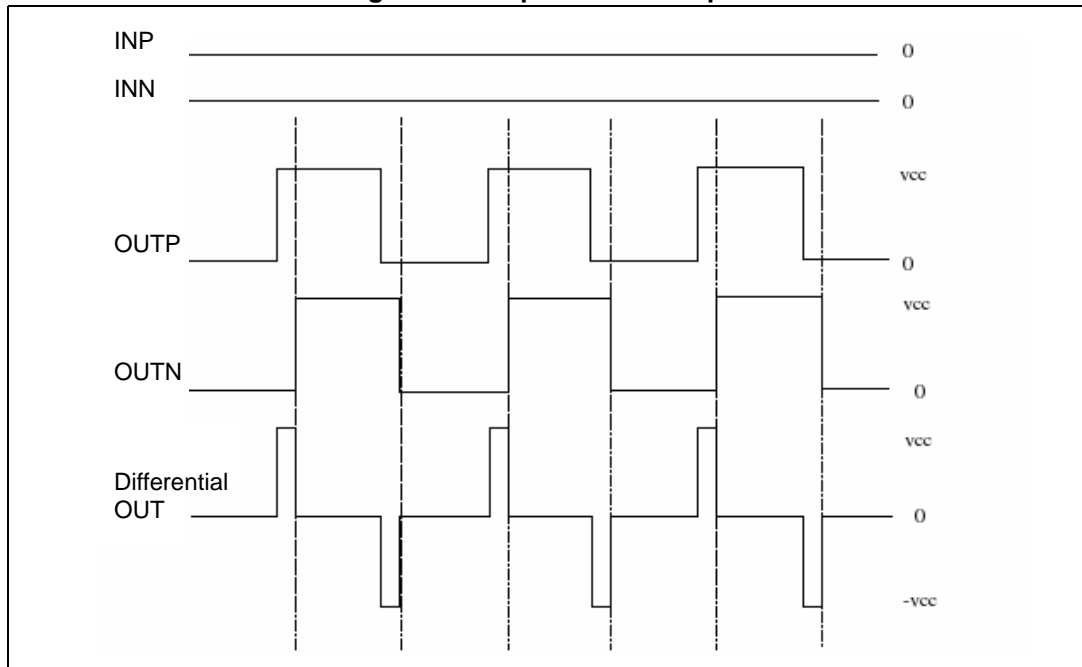

7.6 Output low-pass filter

To avoid EMI problems, it may be necessary to use a low-pass filter before the speaker. The cutoff frequency should be larger than 22 kHz and much lower than the output switching frequency. It is necessary to choose the L-C component values depending on the loud speaker impedance. Some typical values, which give a cut-off frequency of 27 kHz, are shown in [Figure 24](#) and [Figure 25](#) below.

Figure 24. Typical LC filter for a 8 Ω speaker

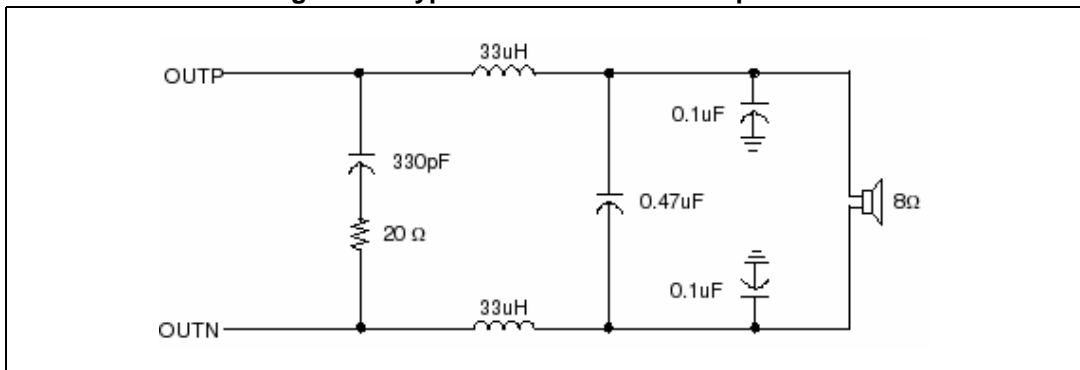
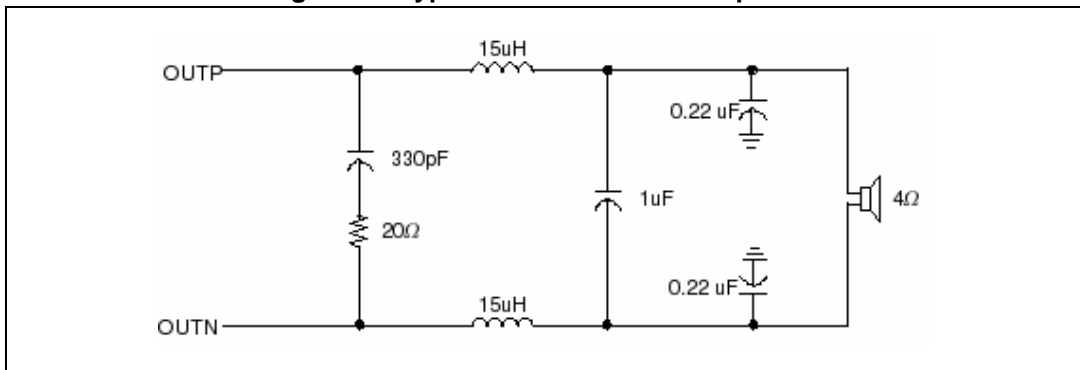

Figure 25. Typical LC filter for a 4 Ω speaker



7.7 Protection function

The TDA7491MV is fully protected against overvoltage, undervoltage, overcurrent and thermal overloads as explained here.

Overvoltage protection (OVP)

If the supply voltage exceeds the value for V_{OVP} given in [Table 5: Electrical specifications on page 8](#) the overvoltage protection is activated which forces the outputs to the high-impedance state. When the supply voltage drops to below the threshold value the device restarts.

Undervoltage protection (UVP)

If the supply voltage drops below the value for V_{UVP} given in [Table 5: Electrical specifications on page 8](#) the undervoltage protection is activated which forces the outputs to the high-impedance state. When the supply voltage recovers the device restarts.

Overcurrent protection (OCP)

If the output current exceeds the value for I_{OCP} given in [Table 5: Electrical specifications on page 8](#) the overcurrent protection is activated which forces the outputs to the high-impedance state. Periodically, the device attempts to restart. If the overcurrent condition is still present then the OCP remains active. The restart time, T_{OC} , is determined by the R-C components connected to pin STBY.

Thermal protection (OTP)

If the junction temperature, T_j , reaches 145 °C (nominal), the device goes to mute mode and the positive and negative PWM outputs are forced to 50% duty cycle. If the junction temperature exceeds the value for T_j given in [Table 5: Electrical specifications on page 8](#) the device shuts down and the output is forced to the high impedance state. When the device cools sufficiently the device restarts.

7.8 Diagnostic output

The output pin DIAG is an open drain transistor. When the protection is activated it is in the high-impedance state. The pin can be connected to a power supply (< 18 V) by a pull-up resistor whose value is limited by the maximum sinking current (200 μ A) of the pin.

Figure 26. Behavior of pin DIAG for various protection conditions

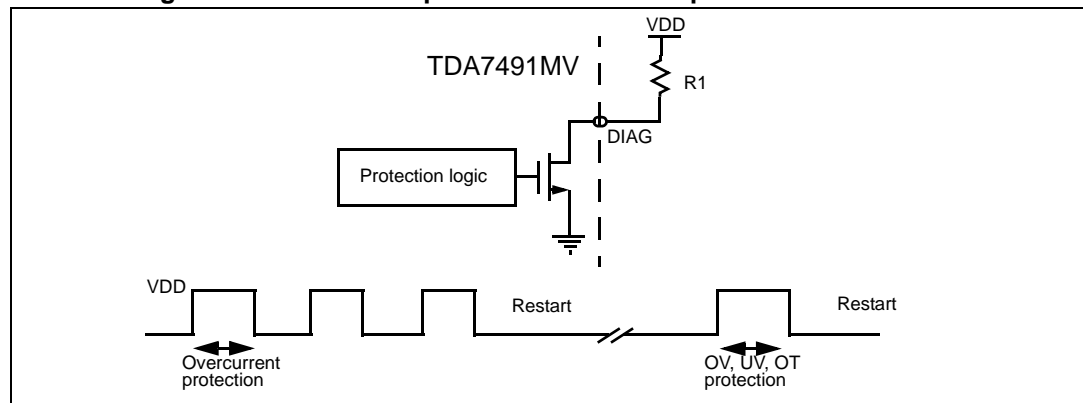

7.9 Heatsink requirements

A thermal resistance of 24 °C/W can be obtained using the PCB copper ground layer with 16 vias connecting it to the contact area for the exposed pad. Ensure that the copper ground area is a nominal 9 cm² for 24 °C/W.

Figure 27 shows the derating curves for copper areas of 4 cm² and 9 cm².

As with most amplifiers, the power dissipated within the device depends primarily on the supply voltage, the load impedance and the output modulation level.

The maximum estimated power dissipation for the TDA7491MV is less than 4 W. When properly mounted on the above PCB the junction temperature could increase by 96 °C. However, with a musical program the dissipated power is about 40% less, leading to a temperature increase of around 60 °C. Even at the maximum recommended ambient temperature for consumer applications of 50 °C there is still a clear safety margin before the maximum junction temperature (150 °C) is reached.

Figure 27. Power derating curves for PCB used as heatsink

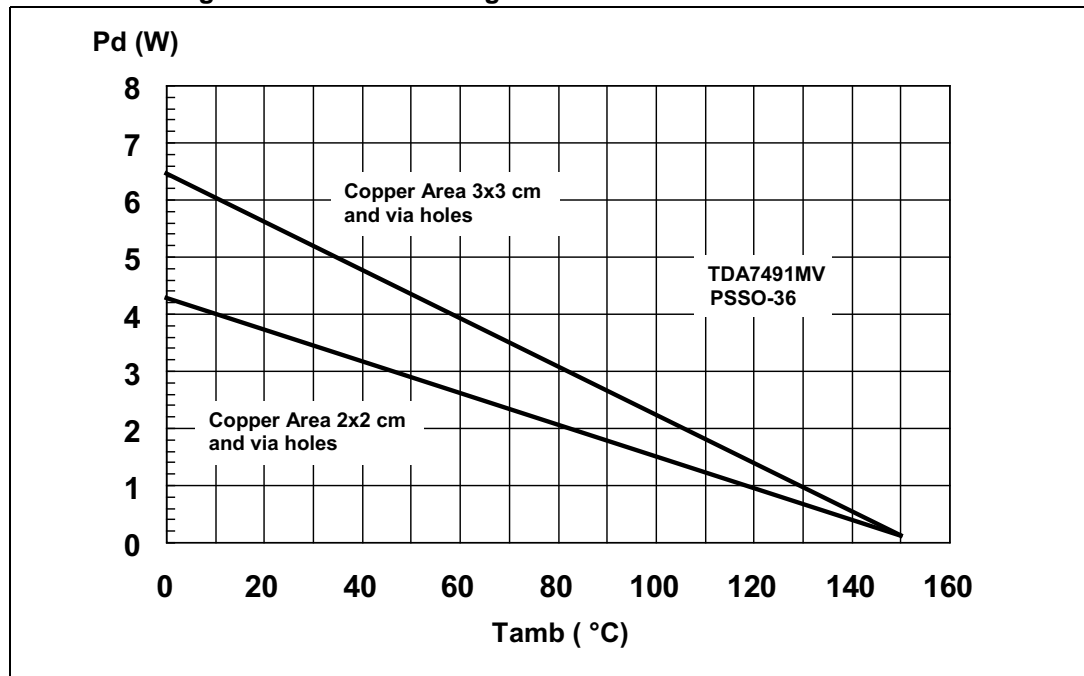

8 Revision history

Table 10. Document revision history

Date	Revision	Changes
21-Oct-2008	1	Initial release.
29-May-2009	2	<p>Updated text concerning oscillator R and C in Section 3.3: Electrical specifications on page 8</p> <p>Updated test condition for I_q, added V_{UV_P}, updated STBY and MUTE voltages and rectified several anomalies in Table 5: Electrical specifications on page 8</p> <p>Updated equation for f_{SW} on page 10 and on page 22</p> <p>Updated Figure 16: Test board (TDA7491HV) layout on page 16</p> <p>Updated Figure 17: PowerSSO-36 EPD outline drawing on page 17 and Table 6: PowerSSO-36 EPD dimensions on page 18</p> <p>Updated Figure 18: Applications circuit for class-D amplifier on page 19</p>
20-Feb-2014	3	Updated order code Table 1 on page 1
21-Mar-2014	4	Updated operating temperature range from 0 to 70 °C in - 40 to 85 °C Table 1 on page 1 and Table 3 on page 8

Please Read Carefully:

Information in this document is provided solely in connection with ST products. STMicroelectronics NV and its subsidiaries ("ST") reserve the right to make changes, corrections, modifications or improvements, to this document, and the products and services described herein at any time, without notice.

All ST products are sold pursuant to ST's terms and conditions of sale.

Purchasers are solely responsible for the choice, selection and use of the ST products and services described herein, and ST assumes no liability whatsoever relating to the choice, selection or use of the ST products and services described herein.

No license, express or implied, by estoppel or otherwise, to any intellectual property rights is granted under this document. If any part of this document refers to any third party products or services it shall not be deemed a license grant by ST for the use of such third party products or services, or any intellectual property contained therein or considered as a warranty covering the use in any manner whatsoever of such third party products or services or any intellectual property contained therein.

UNLESS OTHERWISE SET FORTH IN ST'S TERMS AND CONDITIONS OF SALE ST DISCLAIMS ANY EXPRESS OR IMPLIED WARRANTY WITH RESPECT TO THE USE AND/OR SALE OF ST PRODUCTS INCLUDING WITHOUT LIMITATION IMPLIED WARRANTIES OF MERCHANTABILITY, FITNESS FOR A PARTICULAR PURPOSE (AND THEIR EQUIVALENTS UNDER THE LAWS OF ANY JURISDICTION), OR INFRINGEMENT OF ANY PATENT, COPYRIGHT OR OTHER INTELLECTUAL PROPERTY RIGHT.

ST PRODUCTS ARE NOT DESIGNED OR AUTHORIZED FOR USE IN: (A) SAFETY CRITICAL APPLICATIONS SUCH AS LIFE SUPPORTING, ACTIVE IMPLANTED DEVICES OR SYSTEMS WITH PRODUCT FUNCTIONAL SAFETY REQUIREMENTS; (B) AERONAUTIC APPLICATIONS; (C) AUTOMOTIVE APPLICATIONS OR ENVIRONMENTS, AND/OR (D) AEROSPACE APPLICATIONS OR ENVIRONMENTS. WHERE ST PRODUCTS ARE NOT DESIGNED FOR SUCH USE, THE PURCHASER SHALL USE PRODUCTS AT PURCHASER'S SOLE RISK, EVEN IF ST HAS BEEN INFORMED IN WRITING OF SUCH USAGE, UNLESS A PRODUCT IS EXPRESSLY DESIGNATED BY ST AS BEING INTENDED FOR "AUTOMOTIVE, AUTOMOTIVE SAFETY OR MEDICAL" INDUSTRY DOMAINS ACCORDING TO ST PRODUCT DESIGN SPECIFICATIONS. PRODUCTS FORMALLY ESCC, QML OR JAN QUALIFIED ARE DEEMED SUITABLE FOR USE IN AEROSPACE BY THE CORRESPONDING GOVERNMENTAL AGENCY.

Resale of ST products with provisions different from the statements and/or technical features set forth in this document shall immediately void any warranty granted by ST for the ST product or service described herein and shall not create or extend in any manner whatsoever, any liability of ST.

ST and the ST logo are trademarks or registered trademarks of ST in various countries.

Information in this document supersedes and replaces all information previously supplied.

The ST logo is a registered trademark of STMicroelectronics. All other names are the property of their respective owners.

© 2014 STMicroelectronics - All rights reserved

STMicroelectronics group of companies

Australia - Belgium - Brazil - Canada - China - Czech Republic - Finland - France - Germany - Hong Kong - India - Israel - Italy - Japan - Malaysia - Malta - Morocco - Philippines - Singapore - Spain - Sweden - Switzerland - United Kingdom - United States of America

www.st.com

Компания «Океан Электроники» предлагает заключение долгосрочных отношений при поставках импортных электронных компонентов на взаимовыгодных условиях!

Наши преимущества:

- Поставка оригинальных импортных электронных компонентов напрямую с производств Америки, Европы и Азии, а так же с крупнейших складов мира;
- Широкая линейка поставок активных и пассивных импортных электронных компонентов (более 30 млн. наименований);
- Поставка сложных, дефицитных, либо снятых с производства позиций;
- Оперативные сроки поставки под заказ (от 5 рабочих дней);
- Экспресс доставка в любую точку России;
- Помощь Конструкторского Отдела и консультации квалифицированных инженеров;
- Техническая поддержка проекта, помощь в подборе аналогов, поставка прототипов;
- Поставка электронных компонентов под контролем ВП;
- Система менеджмента качества сертифицирована по Международному стандарту ISO 9001;
- При необходимости вся продукция военного и аэрокосмического назначения проходит испытания и сертификацию в лаборатории (по согласованию с заказчиком);
- Поставка специализированных компонентов военного и аэрокосмического уровня качества (Xilinx, Altera, Analog Devices, Intersil, Interpoint, Microsemi, Actel, Aeroflex, Peregrine, VPT, Syfer, Eurofarad, Texas Instruments, MS Kennedy, Miteq, Cobham, E2V, MA-COM, Hittite, Mini-Circuits, General Dynamics и др.);

Компания «Океан Электроники» является официальным дистрибьютором и эксклюзивным представителем в России одного из крупнейших производителей разъемов военного и аэрокосмического назначения «**JONHON**», а так же официальным дистрибьютором и эксклюзивным представителем в России производителя высокотехнологичных и надежных решений для передачи СВЧ сигналов «**FORSTAR**».



JONHON

«**JONHON**» (основан в 1970 г.)

Разъемы специального, военного и аэрокосмического назначения:

(Применяются в военной, авиационной, аэрокосмической, морской, железнодорожной, горно- и нефтедобывающей отраслях промышленности)

«**FORSTAR**» (основан в 1998 г.)

ВЧ соединители, коаксиальные кабели,
кабельные сборки и микроволновые компоненты:

(Применяются в телекоммуникациях гражданского и специального назначения, в средствах связи, РЛС, а так же военной, авиационной и аэрокосмической отраслях промышленности).



Телефон: 8 (812) 309-75-97 (многоканальный)

Факс: 8 (812) 320-03-32

Электронная почта: ocean@oceanchips.ru

Web: <http://oceanchips.ru/>

Адрес: 198099, г. Санкт-Петербург, ул. Калинина, д. 2, корп. 4, лит. А