

V-EA Miniature Circuit Breakers/Manual Motor Controllers

UL listed and CSA certified V-EA Manual Motor Controllers are horsepower rated and suitable as Motor Disconnect. They can also be used for AC General Use, AC Resistance, AC Discharge Lamps and AC Incandescent Lamps.

<i>Miniature Circuit Breaker/Manual Motor Controller Trip Curve Selection Guide</i>	...6-7
<i>B-Trip Characteristics</i>	...8-9
<i>C-Trip Characteristics</i>	...10-11
<i>D-Trip Characteristics</i>	...12-13
<i>E-Trip Characteristics</i>	...14-15
<i>G-Trip Characteristics</i>	...16-17
<i>Z-Trip Characteristics</i>	...18-19
<i>Horsepower Rating Tables</i>	...20
<i>V-EA Internal Resistance</i>	...21
<i>Line Current Frequency Effects on Trip Curve</i>	...21
<i>Mechanical Endurance Ratings</i>	...21
<i>Short Circuit Ratings for V-EA Manual Motor Controllers</i>	...22
<i>Temperature Effects on Trip Curves</i>	...22
<i>Installation Recommendations</i>	...24
<i>V-EA Dimensions</i>	...25
<i>Nonmetallic Enclosure for MCBs</i>	...25

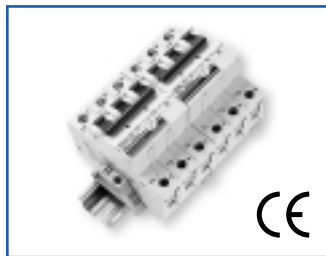

MA Three Phase Adjustable Trip Miniature Circuit Breakers/Manual Motor Controllers

UL listed MA Three Phase Adjustable Manual Motor Controllers have an adjustable thermal trip unit and are especially suitable for high inrush applications, such as transformers, motors, etc.

<i>Ordering and Technical Information</i>	...26-27
---	----------

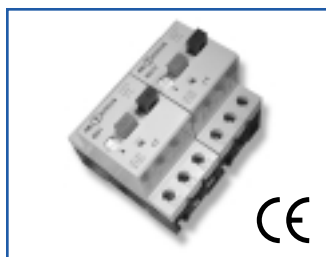

MS Three Phase Adjustable Trip Economy Manual Motor Controller

UL listed MS Three Phase Adjustable Manual Motor Controller is an economical alternative to the MA series. A wide range of accessories which includes: door mounting kit and enclosure, emergency stop attachments, etc.

<i>Ordering and Technical Information</i>	...28-29
---	----------

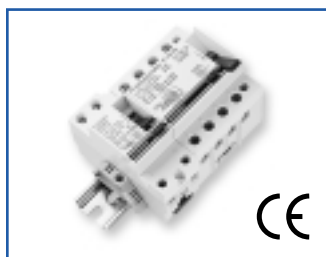

FI Earth Leakage Circuit Breakers

Compact DIN Rail mount FI Earth Leakage Circuit Breakers detect and interrupt ground faults. They are VDE approved for the European system of protecting people, animals, equipment and property from dangerous line-to-ground and shock hazard currents. US applications include ground fault protection of equipment (GFPE), especially when high distributed capacitance or other leakages cause excessive nuisance trips at lower fault currents.

<i>Ordering and Technical Information</i>	...30-31
---	----------

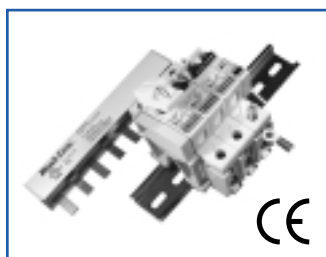

V-EA and MA Miniature Circuit Breaker Accessories

Expand control and monitoring capabilities.

- Shunt Trip
- Undervoltage Trip
- Auxiliary Switch
- Lock-Out
- Cooling Spacer
- Busbar Systems

<i>Accessories</i>	...32-33
--------------------	----------

<i>Busbars</i>	...34-37
<i>The Altech UL508 Solution</i>	...4-5
<i>Standard Terms and Conditions of Sale</i>	...38

Competitors UL1077 Offering

Single Motor Installation

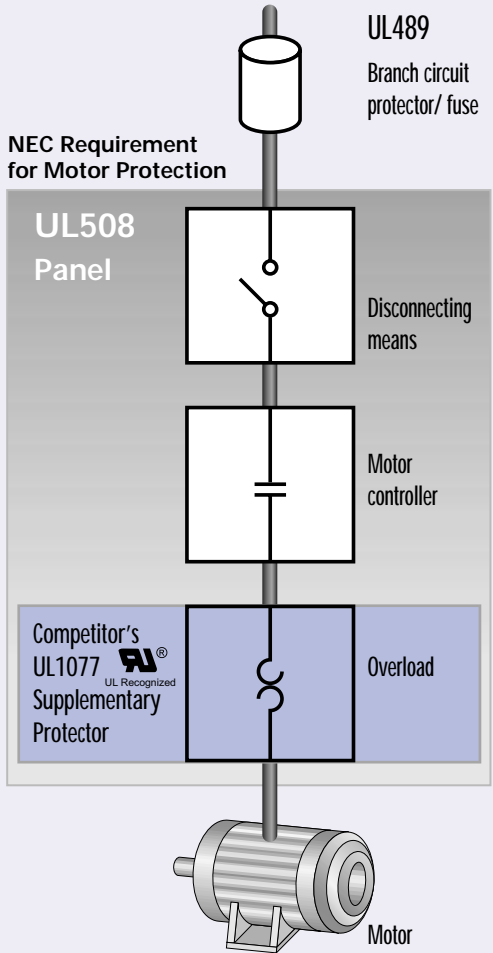

Single Motor Installation

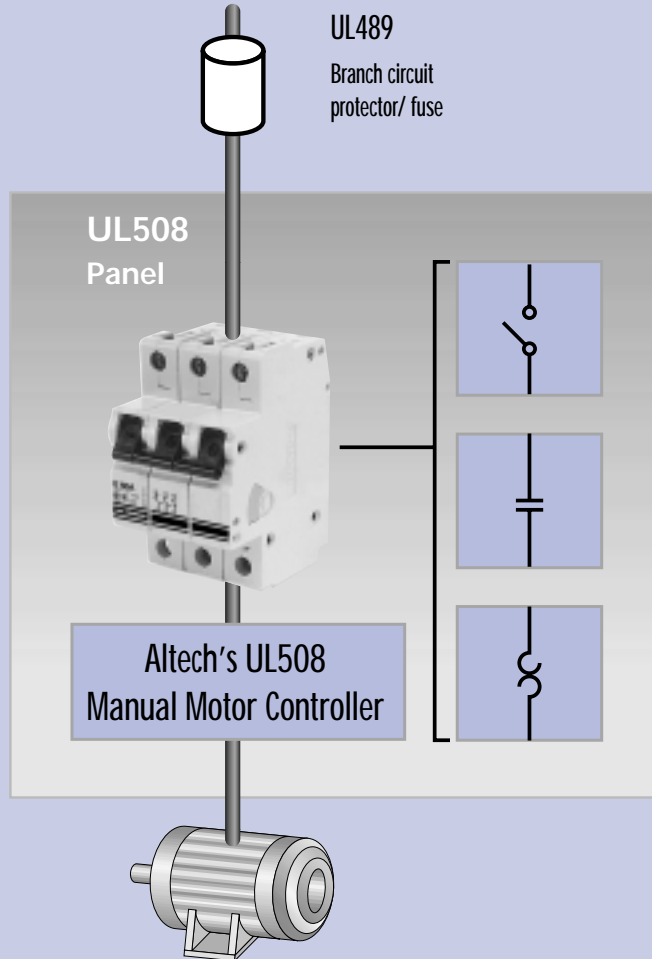

Altech's UL Listed Manual Motor Controllers

General

Altech's manual motor controller is UL listed. The UL Listed mark on the MCB is the manufacturer's representation that samples of the complete product have been tested by UL to be used for most common industrial applications. This superior UL mark allows for field installation without the need for UL investigation.

A competitor's UL recognized component mark on the MCB means that the component alone meets the requirements for a limited, specific use. These MCBs are not intended for separate installation in the field, they are intended for use as a component of complete equipment submitted to UL for investigation.

The **Altech**[®] UL508 Solutions Save money and panel space!

Motor Group Installation

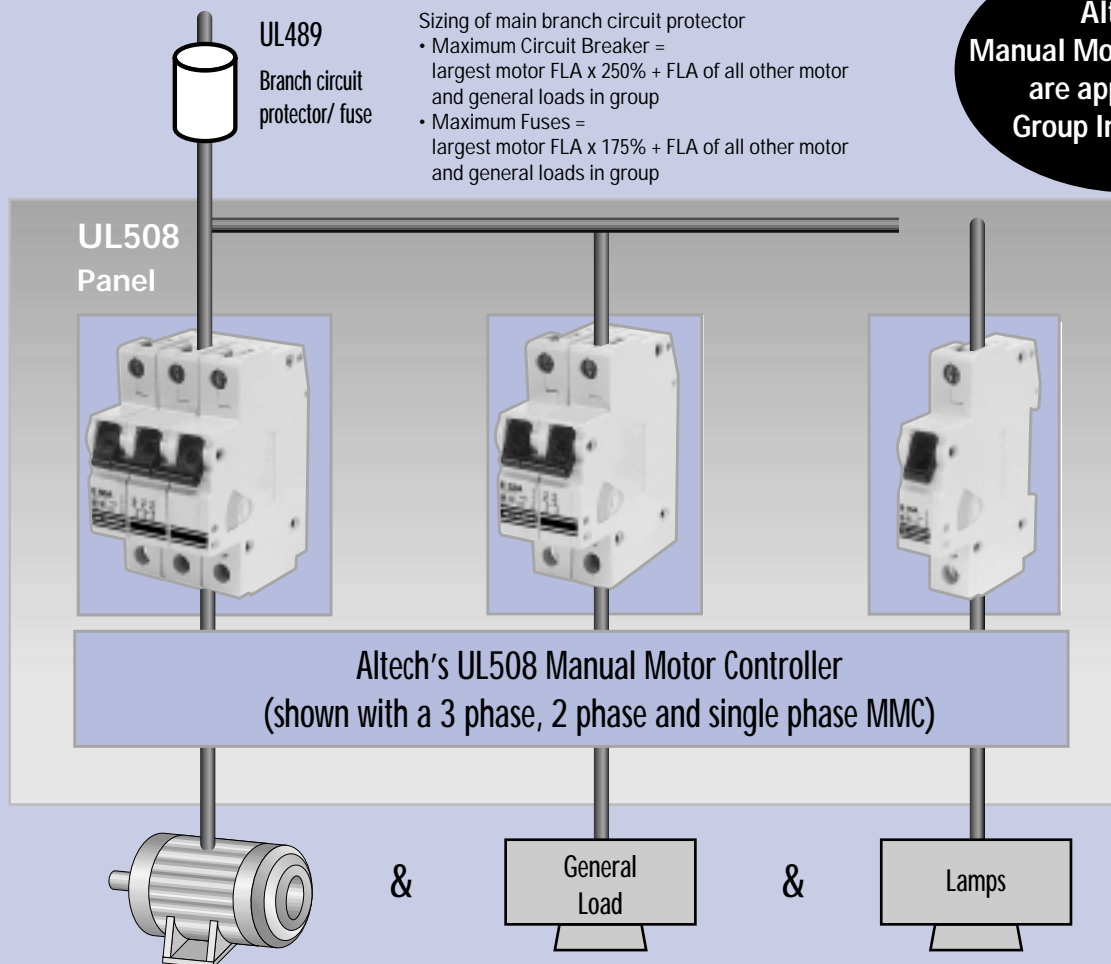

Altech's
Manual Motor Controllers
are approved for
Group Installations

Field Installations

A licensed electrician can install UL508 Manual Motor Controllers for the following uses:

- AC Motor Starting (Across the line)
- AC General Use
- AC Resistance
- AC Discharge Lamps (Ballast)
- AC Incandescent Lamps (Tungsten)

Motor Branch Circuit Uses

(in accordance with NEC[®] Section 430)

UL508 Manual Motor Controller

- Disconnect Means/ Disconnect Switch
- Controller and Overload Protection Combination
- Controller and Disconnect Means Combination

UL 1077 supplementary protector

- None

Interchangeability

A UL Listed Manual Motor Controller can be used in place of UL 1077 Recognized supplementary protector, where UL allowed to use a supplementary protector for a specific application.

However a UL Recognized supplementary protector cannot be used in place of UL Listed Manual Motor Controller for a specific application.

V-EA MINIATURE CIRCUIT BREAKER/MANUAL MOTOR CONTROLLER TRIP CURVE SELECTION GUIDE



Warning!

This information should only be used as a selection guide. The use of a Miniature Circuit Breaker/Manual Motor Controller in an application with a certain Trip-Characteristic always requires prototype testing! It is the responsibility of the circuit design engineer to select the appropriate Miniature Circuit Breaker/Manual Motor Controller for his specific application.

Trip-Characteristics*

Applications

Characteristic Trip Boundaries				Lighting	Wiring Protection	Business Equipment	Appliances	Control Circuits	Transformers	Power Supplies
Thermal Trip		Magnetic Trip								
Must not Trip >100ms	Must Trip <1hr	Must not Trip >100ms	Must Trip at 100ms							
B-Characteristics				Pages 8-9	Pages 8-9	Pages 8-9	Pages 8-9	Pages 8-9		
1.13xRC	1.45xRC	3xRC	5xRC							
C-Characteristics				Pages 10-11	Pages 10-11	Pages 10-11	Pages 10-11	Pages 10-11		
1.13xRC	1.45xRC	5xRC	10xRC							
D-Characteristics									Pages 12-13	Pages 12-13
1.13xRC	1.45xRC	10xRC	16xRC							
E-Characteristics										
1.05xRC	1.35xRC	14xRC	18xRC							
G-Characteristics				Pages 16-17	Pages 16-17				Pages 16-17	Pages 16-17
1.05xRC	1.35xRC	8xRC	10xRC							
Z-Characteristics										
1.05xRC	1.35xRC	2xRC	3xRC							

*The value of each characteristic is shown vertically beneath its corresponding heading.

TIME VERSUS CURRENT TRIP CURVE

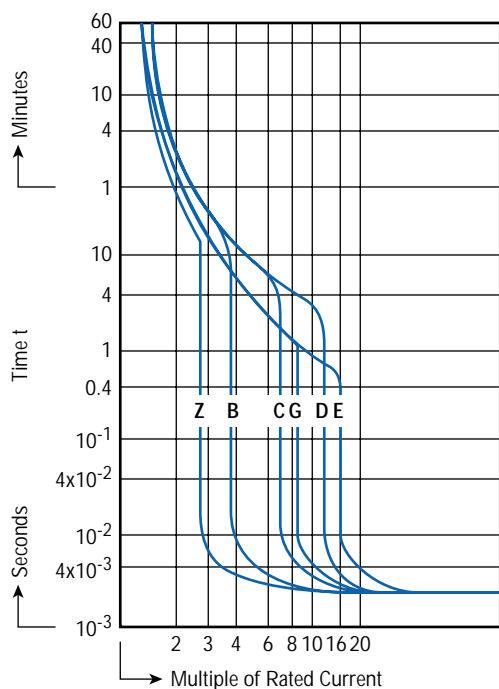

For the exact trip curve, please refer to appropriate catalog pages.

Approvals/Standards:



USA



Canada



Germany



Europe



International

Applications

Heaters	Motors				General Electronics	Solenoid	Semi-conductors	Components/ devices with low surge-current and short circuit withstand capabilities	Reactive Load
	General	Low Inrush	High Inrush	High Efficiency					
					Pages 8-9				
		Pages 10-11							
Pages 12-13			Pages 12-13						Pages 12-13
				Pages 14-15					
	Pages 16-17	Pages 16-17				Pages 16-17			
					Pages 18-19		Pages 18-19	Pages 18-19	



508 listed

UL file E137938



C22.2 No.14 certified

CSA file LR104391

Manual Motor Controller "Suitable as Motor Disconnect"

- AC Motor Starting, Across the Line
- AC General Use
- AC Resistance
- AC Discharge Lamps (Ballast)
- AC Incandescent Lamps (Tungsten)

B-TRIP CHARACTERISTICS

Application Examples:

Business equipment, wiring protection, lighting, appliances, control circuits, some motors and some electronic applications. Relatively long thermal trip delay but low magnetic trip point.

Type Designation

2 B N U 60
(a) **(b)** **(c)** **(d)** **(e)**

- (a)** = Number of Poles
- (b)** = Trip Characteristic
- (c)** = Blank: without neutral pole
= N: with neutral pole
- (d)** = U: UL/CSA version
= R: ring tongue terminals, UL/CSA version
= Blank: European version
- (e)** = Rated Current

Approvals:



Voltage Rating®

Interrupting Capacity (UL/CSA - Ratings)

Group Short Circuit (UL/CSA - Ratings)

Interrupting Capacity (VDE - Ratings)

Mechanical Endurance

Calibration Temperature

Standard Pack and Weight

Terminal Size Acceptability

Terminal Torque

Basic Dimensions (Elevation View)

- ❶ Not European standard rating.
- ❷ Please refer to page 21 for specific applications.
- ❸ DC rating (Manufacturer's self certification): One pole 48VDC, two pole series 125VDC
- * VDE pending

ONE POLE



1B



ONE POLE PLUS NEUTRAL



2BN



Rated Current	Type/ Cat. No.	Approvals	Type/ Cat. No.	Approvals
0.3A	NA		NA	
0.5A	NA		NA	
0.75A	NA		NA	
0.8A❶	NA		NA	
1.0A	1BU1	UL SF	2BNU1	UL SF
1.6A	1BU1.6	UL SF	2BNU1.6	UL SF
2.0A	1BU2	UL SF	2BNU2	UL SF
2.5A	1BU2.5	UL SF	2BNU2.5	UL SF
3.0A	1BU3	UL SF	2BNU3	UL SF
3.5A	1BU3.5	UL SF	2BNU3.5	UL SF
4.0A	1BU4	UL SF	2BNU4	UL SF
5.0A	1BU5	UL SF	2BNU5	UL SF
6.0A	1BU6	UL SF ⚠	2BNU6	UL SF ⚠
8.0A	NA		NA	
10A	1BU10	UL SF ⚠	2BNU10	UL SF ⚠
12A❶	NA		NA	
12.5A	NA		NA	
13A	1BU13	UL SF ⚠	2BNU13	UL SF ⚠
15A❶	1BU15	UL SF	2BNU15	UL SF
16A	1BU16	UL SF ⚠	2BNU16	UL SF ⚠
20A	1BU20	UL SF ⚠	2BNU20	UL SF ⚠
25A	1BU25	UL SF ⚠	2BNU25	UL SF ⚠
30A❶	1BU30	UL SF	2BNU30	UL SF
32A	1BU32	UL SF ⚠*	2BNU32	UL SF ⚠*
40A	1BU40	UL SF ⚠*	2BNU40	UL SF ⚠*
50A	1BU50	UL SF ⚠*	2BNU50	UL SF ⚠*
60A❶	1BU60	UL SF	2BNU60	UL SF
63A	1BU63	⚠*	2BNU63	⚠*
277VAC			277VAC	
0.3-60A (RC): 10kA with UL-listed RK5 back-up fuse or MCCB			0.3-60A (RC): 10kA with UL-listed RK5 back-up fuse or MCCB	
0.3-10A (RC): 10kA; 13-60A (RC): 5kA no branch circuit protection required			0.3-10A (RC): 10kA; 13-60A (RC): 5kA no branch circuit protection required	
0.3-63A (RC): 10kA			0.3-63A (RC): 10kA	
10000 ON/OFF operations❷			10000 ON/OFF operations❷	
40°C (104°F)			40°C (104°F)	
10/0.3A - 32A = 1.4kg (3.1 lb.) 40A - 63A = 1.6kg (3.5 lb.)			5/0.3A - 32A = 1.3kg (2.9 lb.) 40A - 63A = 1.45kg (3.2 lb.)	
Top: 18-3 AWG; Bottom: 18-2 AWG			Top: 18-3 AWG; Bottom: 18-2 AWG	
20 lb.in.			20 lb.in.	

TWO POLE



2B



THREE POLE



3B



Basic Dimensions (side view)

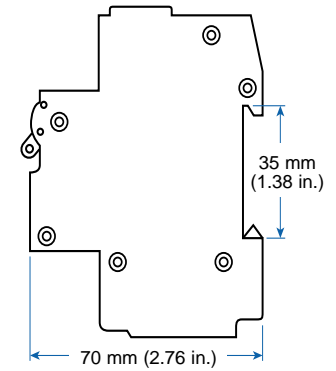

Rated Current	Type/ Cat. No.	Approvals
0.3A	NA	
0.5A	NA	
0.75A	NA	
0.8A ^①	NA	
1.0A	2BU1	UL
1.6A	2BU1.6	UL
2.0A	2BU2	UL
2.5A	2BU2.5	UL
3.0A	2BU3	UL
3.5A	2BU3.5	UL
4.0A	2BU4	UL
5.0A	2BU5	UL
6.0A	2BU6	UL
8.0A	NA	
10A	2BU10	UL
12A ^①	NA	
12.5A	NA	
13A	2BU13	UL
15A ^①	2BU15	UL
16A	2BU16	UL
20A	2BU20	UL
25A	2BU25	UL
30A ^①	2BU30	UL
32A	2BU32	UL
40A	2BU40	UL
50A	2BU50	UL
60A ^①	2BU60	UL
63A	2BU63	UL

480Y/277VAC

0.3-60A (RC): 10kA with UL-listed RK5 back-up fuse or MCCB

0.3-10A (RC): 10kA; 13-60A (RC): 5kA no branch circuit protection required

0.3-63A (RC): 10kA

10000 ON/OFF operations^②

40°C (104°F)

5/1.4kg (3.1 lb.)

Top: 18-3 AWG; Bottom: 18-2 AWG

20 lb.in.

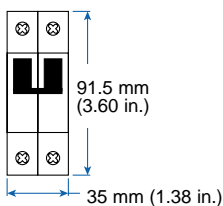

Type/ Cat. No.	Approvals
NA	
NA	
NA	
NA	
3BU1	UL
3BU1.6	UL
3BU2	UL
3BU2.5	UL
3BU3	UL
3BU3.5	UL
3BU4	UL
3BU5	UL
3BU6	UL
NA	
3BU10	UL
NA	
NA	
3BU13	UL
3BU15	UL
3BU16	UL
3BU20	UL
3BU25	UL
3BU30	UL
3BU32	UL
3BU40	UL
3BU50	UL
3BU60	UL
3BU63	UL

480Y/277VAC

0.3-60A (RC): 10kA with UL-listed RK5 back-up fuse or MCCB

0.3-10A (RC): 10kA; 13-60A (RC): 5kA no branch circuit protection required

0.3-63A (RC): 10kA

10000 ON/OFF operations^②

40°C (104°F)

4/1.68kg (3.7 lb.)

Top: 18-3 AWG; Bottom: 18-2 AWG

20 lb.in.

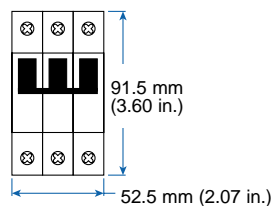

V-EA-B Trip 6.0A Through 10A Rated Current

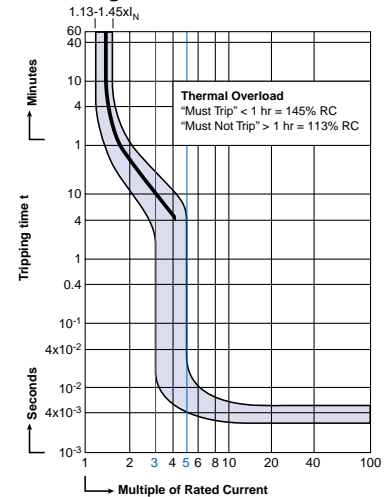

V-EA-B Trip 13A Through 63A Rated Current

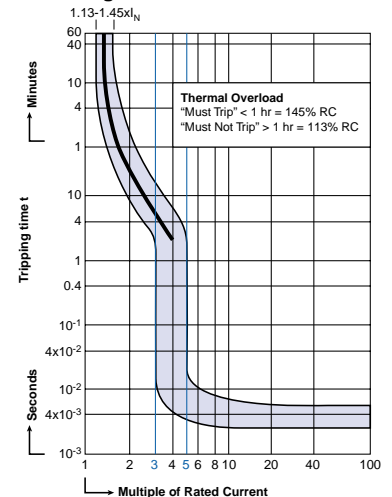

“B” Magnetic Trip Parameters

Rated current 0.3A to 63A.

1. Hold for a minimum of 100ms at surge of 3 times rated current.
2. Trip in under 100ms at 5 times rated current.

NB: Trip curves shown comply with North American standards. For trip curves according to European standards please consult Altech.

C-TRIP CHARACTERISTICS

Application Examples:

Low inrush motors, lighting, wiring protection, appliances, business equipment, and control circuit applications. Relatively long thermal trip delay and medium magnetic trip point.

Type Designation

$\frac{2}{(a)}$ $\frac{C}{(b)}$ $\frac{N}{(c)}$ $\frac{U}{(d)}$ $\frac{60}{(e)}$

- (a) = Number of Poles
- (b) = Trip Characteristic
- (c) = Blank: without neutral pole
= N: with neutral pole
- (d) = U: UL/CSA version
= R: ring tongue terminals, UL/CSA version
= Blank: European version
- (e) = Rated Current

Approvals:



Voltage Rating[Ⓞ]

Interrupting Capacity (UL/CSA - Ratings)

Group Short Circuit (UL/CSA - Ratings)

Interrupting Capacity (VDE - Ratings)

Mechanical Endurance

Calibration Temperature

Standard Pack and Weight

Terminal Size Acceptability

Terminal Torque

Basic Dimensions (Elevation View)

- Ⓛ Not European standard rating.
- Ⓜ Please refer to page 21 for specific applications.
- Ⓨ DC rating (Manufacturer's self certification): One pole 48VDC, two pole series 125VDC
- * VDE pending

ONE POLE



1C

ONE POLE PLUS NEUTRAL



2CN

Rated Current	Type/ Cat. No.	Approvals	Type/ Cat. No.	Approvals
0.3A	1CU03	UL SP Ⓨ	2CNU03	UL SP Ⓨ
0.5A	1CU05	UL SP Ⓨ	2CNU05	UL SP Ⓨ
0.75A	1CU075	UL SP Ⓨ	2CNU075	UL SP Ⓨ
0.8A [Ⓛ]	NA		NA	
1.0A	1CU1	UL SP Ⓨ	2CNU1	UL SP Ⓨ
1.6A	1CU1.6	UL SP Ⓨ	2CNU1.6	UL SP Ⓨ
2.0A	1CU2	UL SP Ⓨ	2CNU2	UL SP Ⓨ
2.5A	1CU2.5	UL SP Ⓨ	2CNU2.5	UL SP Ⓨ
3.0A	1CU3	UL SP Ⓨ	2CNU3	UL SP Ⓨ
3.5A	1CU3.5	UL SP Ⓨ	2CNU3.5	UL SP Ⓨ
4.0A	1CU4	UL SP Ⓨ	2CNU4	UL SP Ⓨ
5.0A	1CU5	UL SP Ⓨ	2CNU5	UL SP Ⓨ
6.0A	1CU6	UL SP Ⓨ	2CNU6	UL SP Ⓨ
8.0A	1CU8	UL SP Ⓨ	2CNU8	UL SP Ⓨ
10A	1CU10	UL SP Ⓨ	2CNU10	UL SP Ⓨ
12A [Ⓛ]	NA		NA	
12.5A	NA		NA	
13A	1CU13	UL SP Ⓨ	2CNU13	UL SP Ⓨ
15A [Ⓛ]	1CU15	UL SP	2CNU15	UL SP
16A	1CU16	UL SP Ⓨ	2CNU16	UL SP Ⓨ
20A	1CU20	UL SP Ⓨ	2CNU20	UL SP Ⓨ
25A	1CU25	UL SP Ⓨ	2CNU25	UL SP Ⓨ
30A [Ⓛ]	1CU30	UL SP	2CNU30	UL SP
32A	1CU32	UL SP Ⓨ *	2CNU32	UL SP Ⓨ *
40A	1CU40	UL SP Ⓨ *	2CNU40	UL SP Ⓨ *
50A	1CU50	UL SP Ⓨ *	2CNU50	UL SP Ⓨ *
60A [Ⓛ]	1CU60	UL SP	2CNU60	UL SP
63A	1CU63	Ⓨ *	2CNU63	Ⓨ *
277VAC			277VAC	
Interrupting Capacity (UL/CSA - Ratings)	0.3-60A (RC): 10kA with UL-listed RK5 back-up fuse or MCCB		0.3-60A (RC): 10kA with UL-listed RK5 back-up fuse or MCCB	
Group Short Circuit (UL/CSA - Ratings)	0.3-10A (RC): 10kA; 13-60A (RC): 5kA no branch circuit protection required		0.3-10A (RC): 10kA; 13-60A (RC): 5kA no branch circuit protection required	
Interrupting Capacity (VDE - Ratings)	0.3-63A (RC): 10kA		0.3-63A (RC): 10kA	
Mechanical Endurance	10000 ON/OFF operations [Ⓜ]		10000 ON/OFF operations [Ⓜ]	
Calibration Temperature	40°C (104°F)		40°C (104°F)	
Standard Pack and Weight	10/0.3A - 32A = 1.4kg (3.1 lb.) 40A - 63A = 1.6kg (3.5 lb.)		5/0.3A - 32A = 1.3kg (2.9 lb.) 40A - 63A = 1.45kg (3.2 lb.)	
Terminal Size Acceptability	Top: 18-3 AWG; Bottom: 18-2 AWG		Top: 18-3 AWG; Bottom: 18-2 AWG	
Terminal Torque	20 lb.in.		20 lb.in.	
Basic Dimensions (Elevation View)				

TWO POLE



2C



THREE POLE



3C



Basic Dimensions (side view)

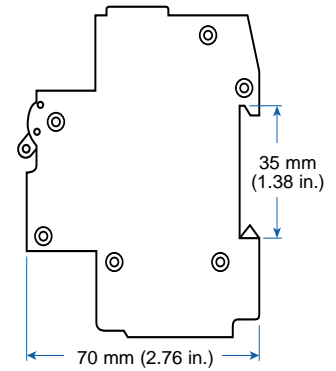

Rated Current **Type/ Cat. No.** **Approvals**

0.3A	2CU03	UL, IEC, CSA
0.5A	2CU05	UL, IEC, CSA
0.75A	2CU075	UL, IEC, CSA
0.8A	NA	
1.0A	2CU1	UL, IEC, CSA
1.6A	2CU1.6	UL, IEC, CSA
2.0A	2CU2	UL, IEC, CSA
2.5A	2CU2.5	UL, IEC, CSA
3.0A	2CU3	UL, IEC, CSA
3.5A	2CU3.5	UL, IEC, CSA
4.0A	2CU4	UL, IEC, CSA
5.0A	2CU5	UL, IEC, CSA
6.0A	2CU6	UL, IEC, CSA
8.0A	2CU8	UL, IEC, CSA
10A	2CU10	UL, IEC, CSA
12A	NA	
12.5A	NA	
13A	2CU13	UL, IEC, CSA
15A	2CU15	UL, IEC, CSA
16A	2CU16	UL, IEC, CSA
20A	2CU20	UL, IEC, CSA
25A	2CU25	UL, IEC, CSA
30A	2CU30	UL, IEC, CSA
32A	2CU32	UL, IEC, CSA*
40A	2CU40	UL, IEC, CSA*
50A	2CU50	UL, IEC, CSA*
60A	2CU60	UL, IEC, CSA
63A	2CU63	UL, IEC, CSA*

480Y/277VAC

0.3-60A (RC): 10kA with UL-listed RK5 back-up fuse or MCCB

0.3-10A (RC): 10kA; 13-60A (RC): 5kA no branch circuit protection required

0.3-63A (RC): 10kA

10000 ON/OFF operations[®]

40°C (104°F)

5/1.4kg (3.1 lb.)

Top: 18-3 AWG; Bottom: 18-2 AWG
20 lb.in.

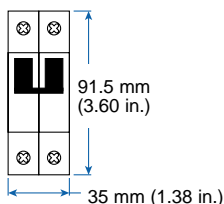

Type/ Cat. No. **Approvals**

3CU03	UL, IEC, CSA
3CU05	UL, IEC, CSA
3CU075	UL, IEC, CSA
NA	
3CU1	UL, IEC, CSA
3CU1.6	UL, IEC, CSA
3CU2	UL, IEC, CSA
3CU2.5	UL, IEC, CSA
3CU3	UL, IEC, CSA
3CU3.5	UL, IEC, CSA
3CU4	UL, IEC, CSA
3CU5	UL, IEC, CSA
3CU6	UL, IEC, CSA
3CU8	UL, IEC, CSA
3CU10	UL, IEC, CSA
NA	
NA	
3CU13	UL, IEC, CSA
3CU15	UL, IEC, CSA
3CU16	UL, IEC, CSA
3CU20	UL, IEC, CSA
3CU25	UL, IEC, CSA
3CU30	UL, IEC, CSA
3CU32	UL, IEC, CSA*
3CU40	UL, IEC, CSA*
3CU50	UL, IEC, CSA*
3CU60	UL, IEC, CSA
3CU63	UL, IEC, CSA*

480Y/277VAC

0.3-60A (RC): 10kA with UL-listed RK5 back-up fuse or MCCB

0.3-10A (RC): 10kA; 13-60A (RC): 5kA no branch circuit protection required

0.3-63A (RC): 10kA

10000 ON/OFF operations[®]

40°C (104°F)

4/1.68kg (3.7 lb.)

Top: 18-3 AWG; Bottom: 18-2 AWG
20 lb.in.

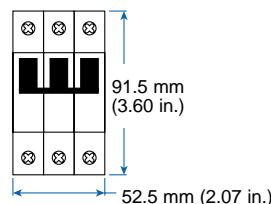

V-EA-C Trip 0.3A Through 10A Rated Current

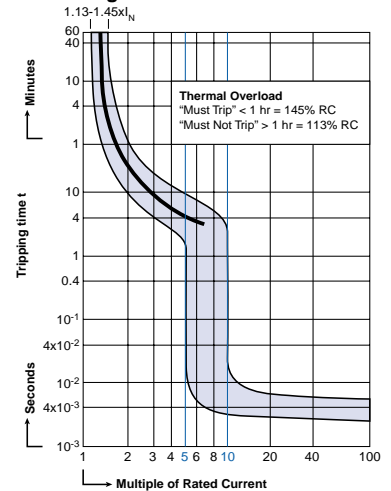

V-EA-C Trip 13A Through 63A Rated Current

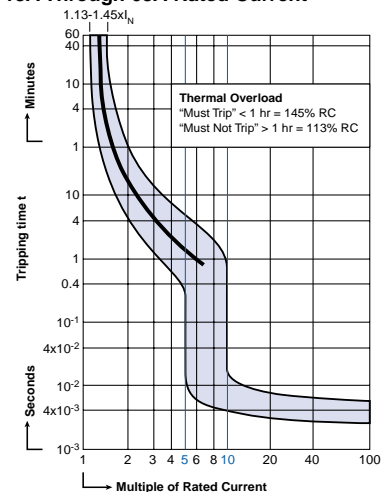

"C" Magnetic Trip Parameters Rated current 0.3A to 63A.

1. Hold for a minimum of 100ms at surge of 5 times rated current.
2. Trip in under 100ms at 10 times rated current.

NB: Trip curves shown comply with North American standards. For trip curves according to European standards please consult Altech.

D-TRIP CHARACTERISTICS

Application Examples:

High inrush motors, transformers, power supplies, heaters and reactive loads. Relatively long thermal trip delay and very high magnetic trip point.

Prototype testing is recommended in motor applications where the relatively long thermal trip delay may not provide adequate motor overload protection. Motor-integral overload protectors are recommended, with the V-EA-D providing disconnect, backup thermal protection and additional short circuit and energy let-through protection.

Type Designation

$\frac{2}{(a)}$ $\frac{D}{(b)}$ $\frac{N}{(c)}$ $\frac{U}{(d)}$ $\frac{60}{(e)}$

- (a) = Number of Poles
- (b) = Trip Characteristic
- (c) = Blank: without neutral pole
= N: with neutral pole
- (d) = U: UL/CSA version
= R: ring tongue terminals, UL/CSA version
= Blank: European version
- (e) = Rated Current

Approvals:



Voltage Rating[®]

Interrupting Capacity (UL/CSA - Ratings)

Group Short Circuit (UL/CSA - Ratings)

Interrupting Capacity (VDE - Ratings)

Mechanical Endurance

Calibration Temperature

Standard Pack and Weight

Terminal Size Acceptability

Terminal Torque

Basic Dimensions (Elevation View)

- ① Not European standard rating.
- ② Please refer to page 21 for specific applications.
- ③ DC rating (Manufacturer's self certification): One pole 48VDC, two pole series 125VDC
- * VDE pending

ONE POLE



1D

Rated Current	Type/ Cat. No.	Approvals
0.3A	1DU03	UL SF
0.5A	1DU05	UL SF
0.75A	1DU075	UL SF
0.8A ^①	NA	
1.0A	1DU1	UL SF
1.6A	1DU1.6	UL SF
2.0A	1DU2	UL SF
2.5A	1DU2.5	UL SF
3.0A	1DU3	UL SF
3.5A	1DU3.5	UL SF
4.0A	1DU4	UL SF
5.0A	1DU5	UL SF
6.0A	1DU6	UL SF
8.0A	1DU8	UL SF
10A	1DU10	UL SF
12A ^①	NA	
12.5A	NA	
13A	1DU13	UL SF
15A ^①	1DU15	UL SF
16A	1DU16	UL SF
20A	1DU20	UL SF
25A	1DU25	UL SF
30A ^①	1DU30	UL SF
32A	1DU32	UL SF *
40A	1DU40	UL SF *
50A	1DU50	UL SF *
60A ^①	1DU60	UL SF
63A	1DU63	UL SF *

277VAC

0.3-60A (RC): 10kA with UL-listed RK5 back-up fuse or MCCB

0.3-10A (RC): 10kA; 13-60A (RC): 5kA
no branch circuit protection required

0.3-63A (RC): 10kA

10000 ON/OFF operations^②

40°C (104°F)

10/0.3A - 32A = 1.4kg (3.1 lb.)
40A - 63A = 1.6kg (3.5 lb.)

Top: 18-3 AWG; Bottom: 18-2 AWG

20 lb.in.

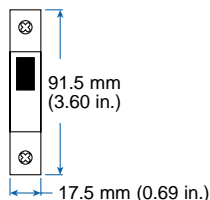

ONE POLE PLUS NEUTRAL



2DN

Type/ Cat. No.	Approvals
2DNU03	UL SF
2DNU05	UL SF
2DNU075	UL SF
NA	
2DNU1	UL SF
2DNU1.6	UL SF
2DNU2	UL SF
2DNU2.5	UL SF
2DNU3	UL SF
2DNU3.5	UL SF
2DNU4	UL SF
2DNU5	UL SF
2DNU6	UL SF
2DNU8	UL SF
2DNU10	UL SF
NA	
NA	
2DNU13	UL SF
2DNU15	UL SF
2DNU16	UL SF
2DNU20	UL SF
2DNU25	UL SF
2DNU30	UL SF
2DNU32	UL SF *
2DNU40	UL SF *
2DNU50	UL SF *
2DNU60	UL SF
2DNU63	UL SF *

277VAC

0.3-60A (RC): 10kA with UL-listed RK5 back-up fuse or MCCB

0.3-10A (RC): 10kA; 13-60A (RC): 5kA
no branch circuit protection required

0.3-63A (RC): 10kA

10000 ON/OFF operations^②

40°C (104°F)

5/0.3A - 32A = 1.3kg (2.9 lb.)
40A - 63A = 1.45kg (3.2 lb.)

Top: 18-3 AWG; Bottom: 18-2 AWG

20 lb.in.

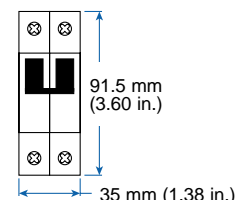

TWO POLE



2D

THREE POLE



3D

Basic Dimensions (side view)

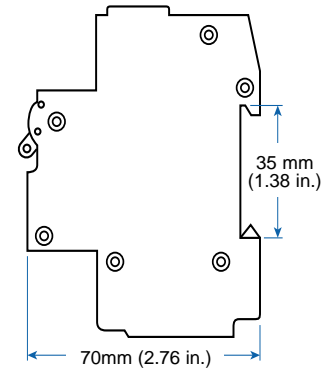

Rated Current	Type/ Cat. No.	Approvals
0.3A	2DU03	UL SF
0.5A	2DU05	UL SF
0.75A	2DU075	UL SF
0.8A	NA	
1.0A	2DU1	UL SF
1.6A	2DU1.6	UL SF
2.0A	2DU2	UL SF
2.5A	2DU2.5	UL SF
3.0A	2DU3	UL SF
3.5A	2DU3.5	UL SF
4.0A	2DU4	UL SF
5.0A	2DU5	UL SF
6.0A	2DU6	UL SF
8.0A	2DU8	UL SF
10A	2DU10	UL SF
12A	NA	
12.5A	NA	
13A	2DU13	UL SF
15A	2DU15	UL SF
16A	2DU16	UL SF
20A	2DU20	UL SF
25A	2DU25	UL SF
30A	2DU30	UL SF
32A	2DU32	UL SF *
40A	2DU40	UL SF *
50A	2DU50	UL SF *
60A	2DU60	UL SF
63A	2DU63	UL SF *

Type/ Cat. No.	Approvals
3DU03	UL SF
3DU05	UL SF
3DU075	UL SF
NA	
3DU1	UL SF
3DU1.6	UL SF
3DU2	UL SF
3DU2.5	UL SF
3DU3	UL SF
3DU3.5	UL SF
3DU4	UL SF
3DU5	UL SF
3DU6	UL SF
3DU8	UL SF
3DU10	UL SF
NA	
NA	
3DU13	UL SF
3DU15	UL SF
3DU16	UL SF
3DU20	UL SF
3DU25	UL SF
3DU30	UL SF
3DU32	UL SF *
3DU40	UL SF *
3DU50	UL SF *
3DU60	UL SF
3DU63	UL SF *

480Y/277VAC

0.3-60A (RC): 10kA with UL-listed RK5 back-up fuse or MCCB

0.3-10A (RC): 10kA; 13-60A (RC): 5kA no branch circuit protection required

0.3-63A (RC): 10kA

10000 ON/OFF operations²

40°C (104°F)

5/1.4kg (3.1 lb.)

Top: 18-3 AWG; Bottom: 18-2 AWG

20 lb.in.

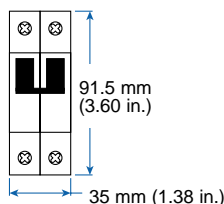

480Y/277VAC

0.3-60A (RC): 10kA with UL-listed RK5 back-up fuse or MCCB

0.3-10A (RC): 10kA; 13-60A (RC): 5kA no branch circuit protection required

0.3-63A (RC): 10kA

10000 ON/OFF operations²

40°C (104°F)

4/1.68kg (3.7 lb.)

Top: 18-3 AWG; Bottom: 18-2 AWG

20 lb.in.

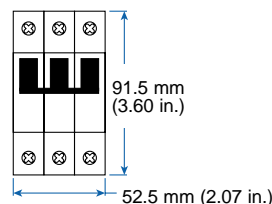

V-EA-D Trip 0.3A Through 10A Rated Current

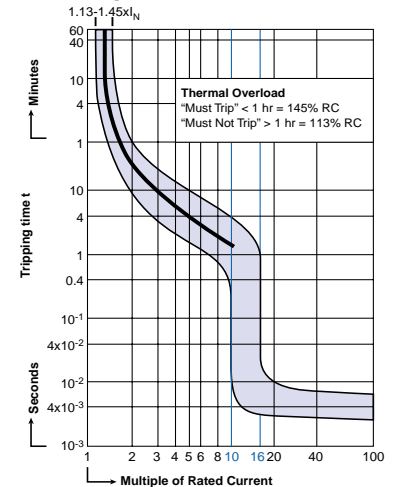

V-EA-D Trip 13A Through 63A Rated Current

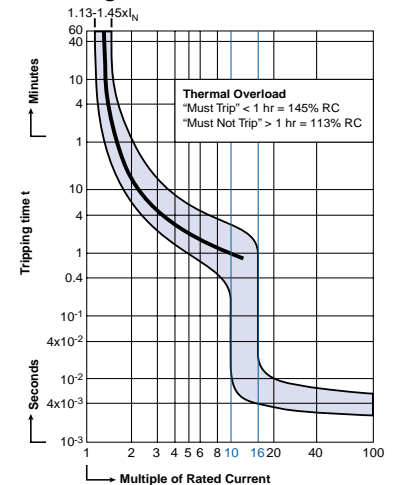

"D" Magnetic Trip Parameters

Rated current 0.3A to 63A.

1. Hold for a minimum of 100ms at surge of 10 times rated current.
2. Trip in under 100ms at 16 times rated current.

NB: Trip curves shown comply with North American standards. For trip curves according to European standards please consult Altech.

E-TRIP CHARACTERISTICS

Application Examples:

High efficiency motors, which have exceedingly high inrush currents. Relatively short thermal trip delays and very high magnetic trip points.

Prototype testing is recommended. The V-EA-E is the result of continuous research and improvement of our G- and D-Trip circuit breakers. It combines the short thermal trip delay of the G-Trip and an even higher magnetic trip point than the D-Trip.

Therefore, the V-EA-E provides adequate motor overload and short circuit protection.

Type Designation

2 E N U 60
(a) **(b)** **(c)** **(d)** **(e)**

- (a)** = Number of Poles
- (b)** = Trip Characteristic
- (c)** = Blank: without neutral pole
 = N: with neutral pole
- (d)** = U: UL/CSA version
 = R: ring tongue terminals, UL/CSA version
 = Blank: European version
- (e)** = Rated Current

Approvals:



UL508 Listed

Voltage Rating[®]

Interrupting Capacity (UL/CSA - Ratings)

Group Short Circuit (UL/CSA - Ratings)

Interrupting Capacity (VDE - Ratings)

Mechanical Endurance

Calibration Temperature

Standard Pack and Weight

Terminal Size Acceptability

Terminal Torque

Basic Dimensions (Elevation View)

- ^① Not European standard rating.
- ^② Please refer to page 21 for specific applications.
- ^③ DC rating (Manufacturer's self certification): One pole 48VDC, two pole series 125VDC

ONE POLE



1E

Rated Current	Type/ Cat. No.	Approvals
0.3A	1EU03	UL SP
0.5A	1EU05	UL SP
0.75A	1EU075	UL SP
0.8A ^①	NA	
1.0A	1EU1	UL SP
1.6A	1EU1.6	UL SP
2.0A	1EU2	UL SP
2.5A	1EU2.5	UL SP
3.0A	1EU3	UL SP
3.5A	1EU3.5	UL SP
4.0A	1EU4	UL SP
5.0A	1EU5	UL SP
6.0A	1EU6	UL SP
8.0A	1EU8	UL SP
10A	1EU10	UL SP
12A ^①	1EU12	UL SP
12.5A	1EU125	UL SP
13A	1EU13	UL SP
15A ^①	1EU15	UL SP
16A	1EU16	UL SP
20A	1EU20	UL SP
25A	1EU25	UL SP
30A ^①	1EU30	UL SP
32A	1EU32	UL SP
40A	1EU40	UL SP
50A	1EU50	UL SP
60A ^①	1EU60	UL SP
63A	1EU63	UL SP

277VAC

0.3-60A (RC): 10kA with UL-listed RK5 back-up fuse or MCCB

0.3-10A (RC): 10kA; 12-60A (RC): 5kA no branch circuit protection required

0.3-63A (RC): 10kA

10000 ON/OFF operations^②

40°C (104°F)

10/0.3A - 32A = 1.4kg (3.1 lb.)
 40A - 63A = 1.6kg (3.5 lb.)

Top: 18-3 AWG; Bottom: 18-2 AWG

20 lb.in.

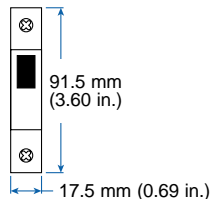

ONE POLE PLUS NEUTRAL



2EN

Type/ Cat. No.	Approvals
2ENU03	UL SP
2ENU05	UL SP
2ENU075	UL SP
NA	
2ENU1	UL SP
2ENU1.6	UL SP
2ENU2	UL SP
2ENU2.5	UL SP
2ENU3	UL SP
2ENU3.5	UL SP
2ENU4	UL SP
2ENU5	UL SP
2ENU6	UL SP
2ENU8	UL SP
2ENU10	UL SP
2ENU12	UL SP
2ENU125	UL SP
2ENU13	UL SP
2ENU15	UL SP
2ENU16	UL SP
2ENU20	UL SP
2ENU25	UL SP
2ENU30	UL SP
2ENU32	UL SP
2ENU40	UL SP
2ENU50	UL SP
2ENU60	UL SP
2ENU63	UL SP

277VAC

0.3-60A (RC): 10kA with UL-listed RK5 back-up fuse or MCCB

0.3-10A (RC): 10kA; 12-60A (RC): 5kA no branch circuit protection required

0.3-63A (RC): 10kA

10000 ON/OFF operations^②

40°C (104°F)

5/0.3A - 32A = 1.3kg (2.9 lb.)
 40A - 63A = 1.45kg (3.2 lb.)

Top: 18-3 AWG; Bottom: 18-2 AWG

20 lb.in.

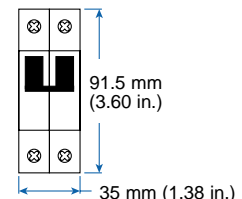

TWO POLE



THREE POLE



Basic Dimensions (side view)

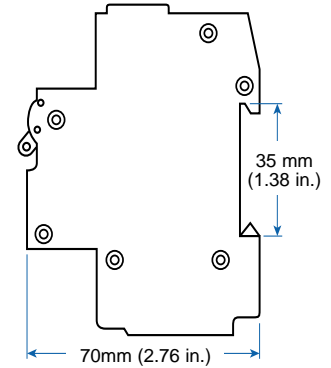

Rated Current	Type/ Cat. No.	Approvals
0.3A	2EU03	UL Ⓢ
0.5A	2EU05	UL Ⓢ
0.75A	2EU075	UL Ⓢ
0.8A	NA	
1.0A	2EU1	UL Ⓢ
1.6A	2EU1.6	UL Ⓢ
2.0A	2EU2	UL Ⓢ
2.5A	2EU2.5	UL Ⓢ
3.0A	2EU3	UL Ⓢ
3.5A	2EU3.5	UL Ⓢ
4.0A	2EU4	UL Ⓢ
5.0A	2EU5	UL Ⓢ
6.0A	2EU6	UL Ⓢ
8.0A	2EU8	UL Ⓢ
10A	2EU10	UL Ⓢ
12A	2EU12	UL Ⓢ
12.5A	2EU125	UL Ⓢ
13A	2EU13	UL Ⓢ
15A	2EU15	UL Ⓢ
16A	2EU16	UL Ⓢ
20A	2EU20	UL Ⓢ
25A	2EU25	UL Ⓢ
30A	2EU30	UL Ⓢ
32A	2EU32	UL Ⓢ
40A	2EU40	UL Ⓢ
50A	2EU50	UL Ⓢ
60A	2EU60	UL Ⓢ
63A	2EU63	UL Ⓢ

Type/ Cat. No.	Approvals
3EU03	UL Ⓢ
3EU05	UL Ⓢ
3EU075	UL Ⓢ
NA	
3EU1	UL Ⓢ
3EU1.6	UL Ⓢ
3EU2	UL Ⓢ
3EU2.5	UL Ⓢ
3EU3	UL Ⓢ
3EU3.5	UL Ⓢ
3EU4	UL Ⓢ
3EU5	UL Ⓢ
3EU6	UL Ⓢ
3EU8	UL Ⓢ
3EU10	UL Ⓢ
3EU12	UL Ⓢ
3EU125	UL Ⓢ
3EU13	UL Ⓢ
3EU15	UL Ⓢ
3EU16	UL Ⓢ
3EU20	UL Ⓢ
3EU25	UL Ⓢ
3EU30	UL Ⓢ
3EU32	UL Ⓢ
3EU40	UL Ⓢ
3EU50	UL Ⓢ
3EU60	UL Ⓢ
3EU63	UL Ⓢ

480Y/277VAC

0.3-60A (RC): 10kA with UL-listed RK5 back-up fuse or MCCB

0.3-10A (RC): 10kA; 12-60A (RC): 5kA no branch circuit protection required

0.3-63A (RC): 10kA

10000 ON/OFF operations[Ⓢ]

40°C (104°F)

5/1.4kg (3.1 lb.)

Top: 18-3 AWG; Bottom: 18-2 AWG

20 lb.in.

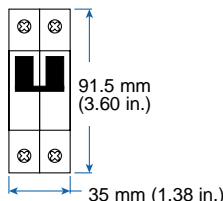

480Y/277VAC

0.3-60A (RC): 10kA with UL-listed RK5 back-up fuse or MCCB

0.3-10A (RC): 10kA; 12-60A (RC): 5kA no branch circuit protection required

0.3-63A (RC): 10kA

10000 ON/OFF operations[Ⓢ]

40°C (104°F)

4/1.68kg (3.7 lb.)

Top: 18-3 AWG; Bottom: 18-2 AWG

20 lb.in.

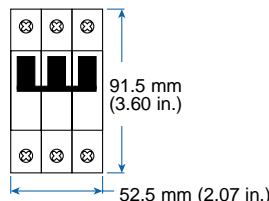

V-EA-E Trip 0.3A Through 10A Rated Current

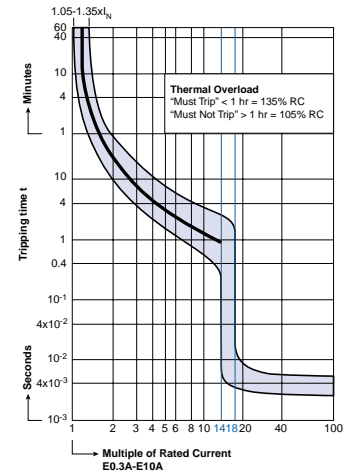

V-EA-E Trip 12A Through 60A Rated Current

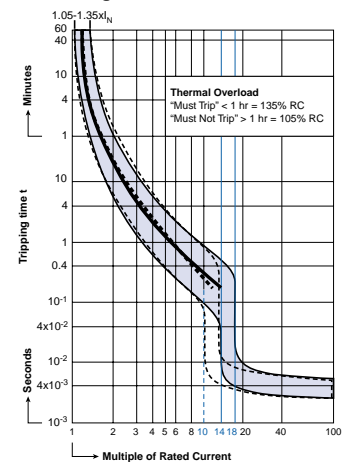

"E" Magnetic Trip Parameters

Rated Current, 0.3A to 50A (———), 60/63A (- - - - -).

Magnetic Trip:

1. Hold for a minimum of 100ms at surge of 14 times (60A, 10 times) rated current.
2. Trip in under 100ms at 18 times (60A, 14 times) rated current.

NB: Trip curves shown comply with North American standards. For trip curves according to European standards please consult Altech.

G-TRIP CHARACTERISTICS

Application Examples:

General industrial, including motors, some transformers, solenoids, control circuits, lighting and wiring. Meets the US trip norms with relatively short thermal trip delay and high magnetic trip point.

Type Designation

2 G N U 60
(a) (b) (c) (d) (e)

- (a) = Number of Poles
- (b) = Trip Characteristic
- (c) = Blank: without neutral pole
= N: with neutral pole
- (d) = U: UL/CSA version
= R: ring tongue terminals, UL/CSA version
= Blank: European version
- (e) = Rated Current

Approvals:



Voltage Rating[®]

Interrupting Capacity (UL/CSA - Ratings)

Group Short Circuit (UL/CSA - Ratings)

Interrupting Capacity (VDE - Ratings)

Mechanical Endurance

Calibration Temperature

Standard Pack and Weight

Terminal Size Acceptability

Terminal Torque

Basic Dimensions (Elevation View)

- ❶ Not European standard rating.
- ❷ Please refer to page 21 for specific applications.
- ❸ DC rating (Manufacturer's self certification): One pole 48VDC, two pole series 125VDC
- * AC Motor Starting, Across-the-line approval pending

ONE POLE



1G

Rated Current	Type/ Cat. No.	Approvals
0.3A	1GU03	UL Ⓢ
0.5A	1GU05	UL Ⓢ
0.75A	NA	
0.8A❶	1GU08	UL Ⓢ
1.0A	1GU1	UL Ⓢ
1.6A	1GU1.6	UL Ⓢ
2.0A	1GU2	UL Ⓢ
2.5A	1GU2.5	UL Ⓢ
3.0A	1GU3	UL Ⓢ
3.5A	1GU3.5	UL Ⓢ
4.0A	1GU4	UL Ⓢ
5.0A	1GU5	UL Ⓢ
6.0A	1GU6	UL Ⓢ
8.0A	1GU8	UL Ⓢ
10A	1GU10	UL Ⓢ
12A❶	1GU12	UL Ⓢ
12.5A	1GU125	UL Ⓢ
13A	1GU13	UL Ⓢ
15A❶	1GU15	UL Ⓢ
16A	1GU16	UL Ⓢ
20A	1GU20	UL Ⓢ
25A	1GU25	UL Ⓢ
30A❶	1GU30	UL Ⓢ
32A	1GU32	UL Ⓢ
40A	1GU40	UL Ⓢ
50A	1GU50	UL Ⓢ
60A❶	1GU60	UL Ⓢ
63A	1GU63	

277VAC

0.3-60A (RC): 10kA with UL-listed RK5 back-up fuse or MCCB

0.3-10A (RC): 10kA; 12-60A (RC): 5kA no branch circuit protection required

0.3-63A (RC): 10kA

10000 ON/OFF operations^❸

40°C (104°F)

10/0.3A - 32A = 1.4kg (3.1 lb.)
40A - 63A = 1.6kg (3.5 lb.)

Top: 18-3 AWG; Bottom: 18-2 AWG

20 lb.in.

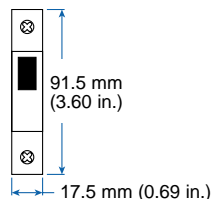

ONE POLE PLUS NEUTRAL



2GN

Type/ Cat. No.	Approvals
2GNU03	UL Ⓢ
2GNU05	UL Ⓢ
NA	
2GNU08	UL Ⓢ
2GNU1	UL Ⓢ
2GNU1.6	UL Ⓢ
2GNU2	UL Ⓢ
2GNU2.5	UL Ⓢ
2GNU3	UL Ⓢ
2GNU3.5	UL Ⓢ
2GNU4	UL Ⓢ
2GNU5	UL Ⓢ
2GNU6	UL Ⓢ
2GNU8	UL Ⓢ
2GNU10	UL Ⓢ
2GNU12	UL Ⓢ
2GNU125	UL Ⓢ
2GNU13	UL Ⓢ
2GNU15	UL Ⓢ
2GNU16	UL Ⓢ
2GNU20	UL Ⓢ
2GNU25	UL Ⓢ
2GNU30	UL Ⓢ
2GNU32	UL Ⓢ
2GNU40	UL Ⓢ
2GNU50	UL Ⓢ
2GNU60	UL Ⓢ
2GNU63	

277VAC

0.3-60A (RC): 10kA with UL-listed RK5 back-up fuse or MCCB

0.3-10A (RC): 10kA; 12-60A (RC): 5kA no branch circuit protection required

0.3-63A (RC): 10kA

10000 ON/OFF operations^❸

40°C (104°F)

5/0.3A - 32A = 1.3kg (2.9 lb.)
40A - 63A = 1.45kg (3.2 lb.)

Top: 18-3 AWG; Bottom: 18-2 AWG

20 lb.in.

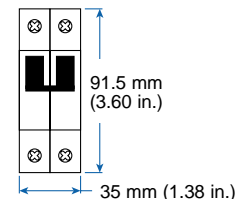

TWO POLE



2G

THREE POLE



3G

Basic Dimensions (side view)

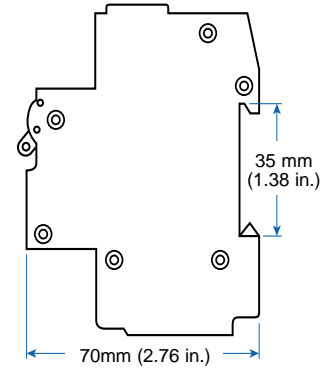

Rated Current **Type/ Cat. No.** **Approvals**

0.3A	2GU03	UL SF
0.5A	2GU05	UL SF
0.75A	NA	
0.8A	2GU08	UL SF
1.0A	2GU1	UL SF
1.6A	2GU1.6	UL SF
2.0A	2GU2	UL SF
2.5A	2GU2.5	UL SF
3.0A	2GU3	UL SF
3.5A	2GU3.5	UL SF
4.0A	2GU4	UL SF
5.0A	2GU5	UL SF
6.0A	2GU6	UL SF
8.0A	2GU8	UL SF
10A	2GU10	UL SF
12A	2GU12	UL SF *
12.5A	2GU125	UL SF *
13A	2GU13	UL SF *
15A	2GU15	UL SF *
16A	2GU16	UL SF *
20A	2GU20	UL SF *
25A	2GU25	UL SF *
30A	2GU30	UL SF *
32A	2GU32	UL SF *
40A	2GU40	UL SF *
50A	2GU50	UL SF *
60A	2GU60	UL SF *
63A	2GU63	UL SF *

Type/ Cat. No. **Approvals**

3GU03	UL SF
3GU05	UL SF
NA	
3GU08	UL SF
3GU1	UL SF
3GU1.6	UL SF
3GU2	UL SF
3GU2.5	UL SF
3GU3	UL SF
3GU3.5	UL SF
3GU4	UL SF
3GU5	UL SF
3GU6	UL SF
3GU8	UL SF
3GU10	UL SF
3GU12	UL SF *
3GU125	UL SF *
3GU13	UL SF *
3GU15	UL SF *
3GU16	UL SF *
3GU20	UL SF *
3GU25	UL SF *
3GU30	UL SF *
3GU32	UL SF *
3GU40	UL SF *
3GU50	UL SF *
3GU60	UL SF *
3GU63	UL SF *

480Y/277VAC

0.3-60A (RC): 10kA with UL-listed RK5 back-up fuse or MCCB

0.3-10A (RC): 10kA; 12-60A (RC): 5kA no branch circuit protection required

0.3-63A (RC): 10kA

10000 ON/OFF operations[Ⓜ]

40°C (104°F)

5/1.4kg (3.1 lb.)

Top: 18-3 AWG; Bottom: 18-2 AWG

20 lb.in.

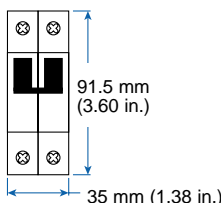

480Y/277VAC

0.3-60A (RC): 10kA with UL-listed RK5 back-up fuse or MCCB

0.3-10A (RC): 10kA; 12-60A (RC): 5kA no branch circuit protection required

0.3-63A (RC): 10kA

10000 ON/OFF operations[Ⓜ]

40°C (104°F)

4/1.68kg (3.7 lb.)

Top: 18-3 AWG; Bottom: 18-2 AWG

20 lb.in.

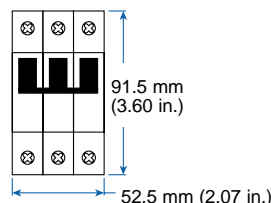

V-EA-G Trip 0.3A Through 10A Rated Current

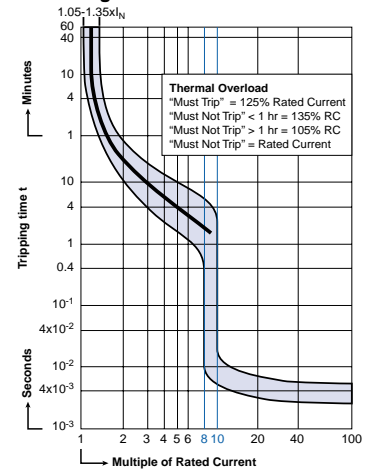

V-EA-G Trip 12A Through 63A Rated Current

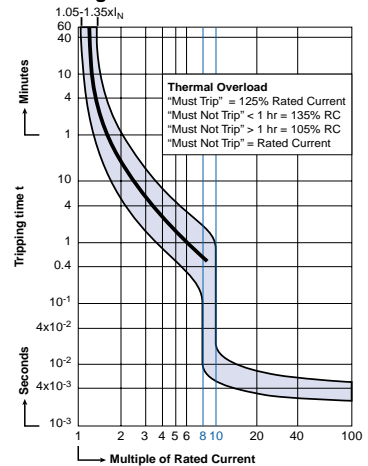

"G" Magnetic Trip Parameters Rated Current, 0.3A to 63A.

Magnetic Trip:

1. Hold for a minimum of 100ms at surge of 8 times rated current.
2. Trip in under 100ms at 10 times rated current.

NB: Trip curves shown comply with North American standards. For trip curves according to European standards please consult Altech.

Z-TRIP CHARACTERISTICS

Application Examples:

Semiconductors, components which fail-short (vs. fail-open), and components/devices with low surge-current and short circuit withstand capabilities. Relatively short thermal delay and very low magnetic trip point.

Type Designation

2 Z N U 30
(a) **(b)** **(c)** **(d)** **(e)**

- (a)** = Number of Poles
- (b)** = Trip Characteristic
- (c)** = Blank: without neutral pole
= N: with neutral pole
- (d)** = U: UL/CSA version
= R: ring tongue terminals, UL/CSA version
= Blank: European version
- (e)** = Rated Current

Approvals:



Voltage Rating[®]

Interrupting Capacity (UL/CSA - Ratings)

Group Short Circuit (UL/CSA - Ratings)

Interrupting Capacity (VDE - Ratings)

Mechanical Endurance

Calibration Temperature

Standard Pack and Weight

Terminal Size Acceptability

Terminal Torque

Basic Dimensions (Elevation View)

- ^① Not European standard rating.
- ^② Please refer to page 21 for specific applications.
- ^③ DC rating (Manufacturer's self certification):
One pole 48VDC, two pole series 125VDC
- * UL and CSA Pending

ONE POLE



1Z

Rated Current	Type/ Cat. No.	Approvals
0.3A	1ZU03	UL Ⓢ
0.5A	1ZU05	UL Ⓢ
0.75A	1ZU075	UL Ⓢ
0.8A ^①	NA	
1.0A	1ZU1	UL Ⓢ
1.6A	1ZU1.6	UL Ⓢ
2.0A	1ZU2	UL Ⓢ
2.5A	1ZU2.5	UL Ⓢ
3.0A	1ZU3	UL Ⓢ
3.5A	1ZU3.5	UL Ⓢ
4.0A	1ZU4	UL Ⓢ
5.0A	1ZU5	UL Ⓢ
6.0A	1ZU6	UL Ⓢ
8.0A	1ZU8	UL Ⓢ
10A	1ZU10	UL Ⓢ
12A ^①	1ZU12	UL Ⓢ
12.5A	1ZU125	UL Ⓢ
13A	1ZU13	UL Ⓢ
15A ^①	1ZU15	UL Ⓢ
16A	1ZU16	UL Ⓢ
20A	1ZU20	UL Ⓢ
25A	1ZU25	UL Ⓢ
30A ^①	1ZU30	UL Ⓢ
32A	1ZU32	UL Ⓢ
40A	1ZU40	UL Ⓢ *
50A	1ZU50	UL Ⓢ *
60A ^①	NA	
63A	NA	

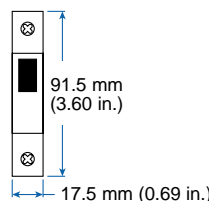

ONE POLE PLUS NEUTRAL



2ZN

Type/ Cat. No.	Approvals
2ZNU03	UL Ⓢ
2ZNU05	UL Ⓢ
2ZNU075	UL Ⓢ
NA	
2ZNU1	UL Ⓢ
2ZNU1.6	UL Ⓢ
2ZNU2	UL Ⓢ
2ZNU2.5	UL Ⓢ
2ZNU3	UL Ⓢ
2ZNU3.5	UL Ⓢ
2ZNU4	UL Ⓢ
2ZNU5	UL Ⓢ
2ZNU6	UL Ⓢ
2ZNU8	UL Ⓢ
2ZNU10	UL Ⓢ
2ZNU12	UL Ⓢ
2ZNU125	UL Ⓢ
2ZNU13	UL Ⓢ
2ZNU15	UL Ⓢ
2ZNU16	UL Ⓢ
2ZNU20	UL Ⓢ
2ZNU25	UL Ⓢ
2ZNU30	UL Ⓢ
2ZNU32	UL Ⓢ
2ZNU40	UL Ⓢ *
2ZNU50	UL Ⓢ *
NA	
NA	

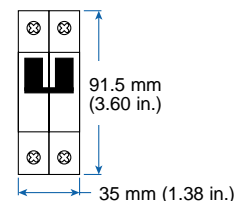

TWO POLE



2Z

THREE POLE



3Z

Basic Dimensions (side view)

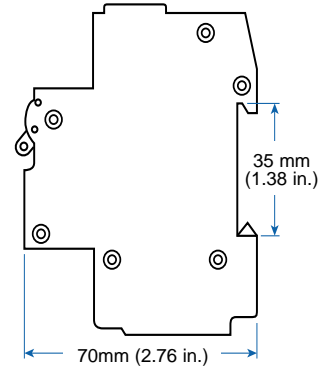

Rated Current	Type/ Cat. No.	Approvals
---------------	-------------------	-----------

0.3A	2ZU03	UL ☞
0.5A	2ZU05	UL ☞
0.75A	2ZU075	UL ☞
0.8A	NA	
1.0A	2ZU1	UL ☞
1.6A	2ZU1.6	UL ☞
2.0A	2ZU2	UL ☞
2.5A	2ZU2.5	UL ☞
3.0A	2ZU3	UL ☞
3.5A	2ZU3.5	UL ☞
4.0A	2ZU4	UL ☞
5.0A	2ZU5	UL ☞
6.0A	2ZU6	UL ☞
8.0A	2ZU8	UL ☞
10A	2ZU10	UL ☞
12A	2ZU12	UL ☞
12.5A	2ZU125	UL ☞
13A	2ZU13	UL ☞
15A	2ZU15	UL ☞
16A	2ZU16	UL ☞
20A	2ZU20	UL ☞
25A	2ZU25	UL ☞
30A	2ZU30	UL ☞
32A	2ZU32	UL ☞
40A	2ZU40	UL ☞ *
50A	2ZU50	UL ☞ *
60A	NA	
63A	NA	

Type/ Cat. No.	Approvals
-------------------	-----------

3ZU03	UL ☞
3ZU05	UL ☞
3ZU075	UL ☞
NA	
3ZU1	UL ☞
3ZU1.6	UL ☞
3ZU2	UL ☞
3ZU2.5	UL ☞
3ZU3	UL ☞
3ZU3.5	UL ☞
3ZU4	UL ☞
3ZU5	UL ☞
3ZU6	UL ☞
3ZU8	UL ☞
3ZU10	UL ☞
3ZU12	UL ☞
3ZU125	UL ☞
3ZU13	UL ☞
3ZU15	UL ☞
3ZU16	UL ☞
3ZU20	UL ☞
3ZU25	UL ☞
3ZU30	UL ☞
3ZU32	UL ☞
3ZU40	UL ☞ *
3ZU50	UL ☞ *
NA	
NA	

480Y/277VAC

0.3-32A (RC): 10kA with UL-listed RK5 back-up fuse or MCCB
 0.3-10A (RC): 10kA; 12-32A (RC): 5kA no branch circuit protection required
 0.3-32A (RC): 10kA
 10000 ON/OFF operations[Ⓜ]
 40°C (104°F)
 5/1.4kg (3.1 lb.)

Top: 18-3 AWG; Bottom: 18-2 AWG
 20 lb.in.

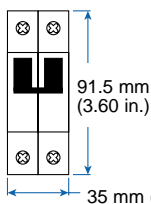

480Y/277VAC

0.3-32A (RC): 10kA with UL-listed RK5 back-up fuse or MCCB
 0.3-10A (RC): 10kA; 12-32A (RC): 5kA no branch circuit protection required
 0.3-32A (RC): 10kA
 10000 ON/OFF operations[Ⓜ]
 40°C (104°F)
 4/1.68kg (3.7 lb.)

Top: 18-3 AWG; Bottom: 18-2 AWG
 20 lb.in.

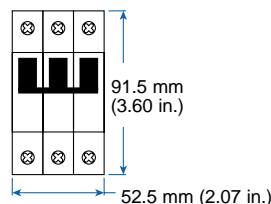

V-EA-Z Trip 0.3A Through 10A Rated Current

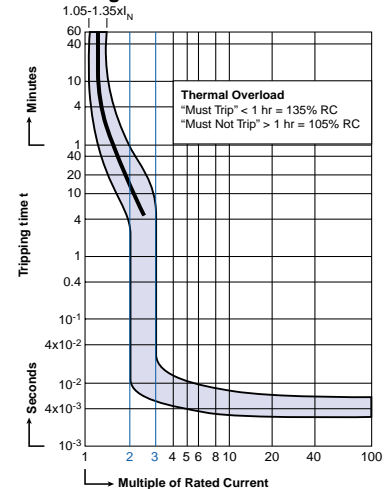

V-EA-Z Trip 12.5A Through 32A Rated Current

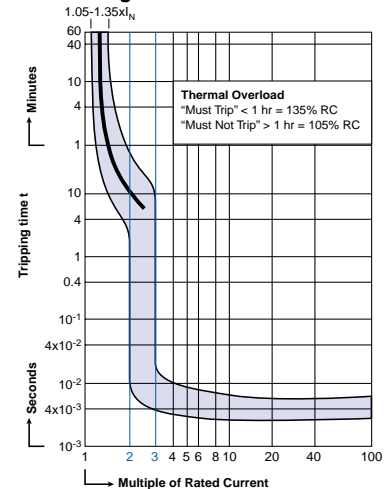

"Z" Trip Parameters

Rated Current, 0.3A to 32A.

Magnetic Trip:

1. Hold for a minimum of 100ms at 2 times rated current.
2. Trip in under 100ms at 3 times rated current.

NB: Trip curves shown comply with North American standards. For trip curves according to European standards please consult Altech.

Table HP 1: AMPERE RATINGS & HORSEPOWER RATING 1 PHASE

			FLA & LRC CONVERTED TO TABLE HORSEPOWER (SEE NOTE #2) USE FLA & LRC RATINGS WHERE NO HP RATING IS GIVEN					
			NOMINAL CIRCUIT VOLTAGE					
V-EA RATED	MOTOR NAMEPLATE	MOTOR NAMEPLATE	110-120 VAC	200 VAC	208 VAC	220-240 VAC	265 VAC	277 VAC
CURRENT (SEE NOTE #1)	FLA RATING	STARTING/LRC RATING						
0.30A 0.50A 0.75A	0.30A 0.50A 0.75A	1.80A 3.00A 4.35A						
0.80A 1.0A 1.6A	0.80A 1.0A 1.6A	4.8A 6.0A 9.6A						
2.0A 2.5A 3.0A	2.0A 2.5A 3.0A	12.0A 15.0A 18.0A		1/6hp 1/6hp	1/6hp 1/6hp	1/6hp 1/6hp 1/4hp	1/6hp 1/6hp 1/4hp	1/6hp 1/4hp 1/3hp
3.5A 4.0A	3.5A 4.0A	21.0A 24.0A		1/4hp 1/4hp	1/4hp 1/3hp	1/4hp 1/3hp	1/3hp 1/3hp	1/3hp 1/3hp
5.0A 6.0A 8.0A	5.0A 6.0A 8.0A	30.0A 36.0A 48.0A	1/6hp 1/4hp 1/3hp	1/3hp 1/2hp 3/4hp	1/2hp 1/2hp 3/4hp	1/2hp 1/2hp 1hp	1/2hp 3/4hp 1hp	1/2hp 3/4hp 1hp
10.0A	10.0A	60.0A	1/2hp	1hp	1hp	1 1/2hp	1 1/2hp	2hp
12.0A 12.5A	12.0A 12.5A	72.0A 75.0A	1/2hp 1/2hp	1 1/2hp 1 1/2hp	1 1/2hp 1 1/2hp	2hp 2hp	2hp 2hp	2hp 2hp
13.0A 15.0A 16.0A	13.0A 15.0A 16.0A	78.0A 90.0A 96.0A	1/2hp 3/4hp 1hp	1 1/2hp 2hp 2hp	1 1/2hp 2hp 2hp	2hp 2hp 2hp	2hp 3hp 3hp	2hp 3hp 3hp
20.0A 25.0A	20.0A 25.0A	120.0A 150.0A	1 1/2hp 2hp	3hp 3hp	3hp 3hp	3hp 3hp	3hp 5hp	3hp 5hp
30.0A	30.0A	180.0A	2hp	3hp	3hp	5hp	5hp	5hp
32.0A	32.0A	192.0A	2hp	3hp	5hp	5hp	5hp	5hp
40.0A	40.0A	240.0A	3hp	5hp	7 1/2hp	7 1/2hp	7 1/2hp	7 1/2hp
50.0A 60.0A	50.0A 60.0A	300.0A 360.0A	3hp 5hp	7 1/2hp 10hp	10hp 10hp	10hp 10hp	10hp 10hp	10hp 15hp

NOTE #1: For AC motor circuit nameplate full load current, AC general-use loads, AC resistance loads, AC incandescent lamp (tungsten) loads, AC electric discharge lamp (ballast) loads.
NOTE #2: Conversions per UL508® Table 45.2 and NFPA-70: National Electrical Code® 1999 Tables 430-148 and 430-151A.

Table HP 2: AMPERE RATING & HORSEPOWER RATING 3 PHASE & 2 PHASE - 4 WIRE

FLA & LRC RATINGS CONVERTED TO TABLE HORSEPOWER (SEE NOTE #2) USE FLA & LRC RATINGS WHERE NO HP IS LISTED													
V-EA RATED CURRENT (SEE NOTE #1)	MOTOR NAMEPLATE FLA RATING	MOTOR NAMEPLATE STARTING/LRC RATING	110-120 VAC		200 VAC		208 VAC		220-240 VAC (SEE NOTE #3)		440-480 VAC		
			Motor Design		Motor Design		Motor Design		Motor Design		Motor Design		
			B, C, D	E	B, C, D	E	B, C, D	E	B, C, D	E	B, C, D	E	
0.30A 0.50A 0.75A	0.30A 0.50A 0.75A	3.0A 5.0A 7.5A											
0.80A 1.0A 1.6A	0.80A 1.0A 1.6A	8.0A 10.0A 16.0A										1/2hp	1/2hp
2.0A 2.5A 3.0A	2.0A 2.5A 3.0A	20.0A 25.0A 30.0A			1/2hp 1/2hp	1/2hp 1/2hp	1/2hp 1/2hp	1/2hp 1/2hp	1/2hp 1/2hp	1/2hp 1/2hp		1/2hp 1hp 1 1/2hp	3/4hp 1hp 1 1/2hp
3.5A 4.0A	3.5A 4.0A	35.0A 40.0A			1/2hp 3/4hp	1/2hp 3/4hp	3/4hp 3/4hp	3/4hp 3/4hp	3/4hp 3/4hp	3/4hp 3/4hp		2hp 2hp	2hp 2hp
5.0A 6.0A 8.0A	5.0A 6.0A 8.0A	42.0A 50.4A 67.2A	1/2hp 1/2hp 3/4hp	1/2hp 1/2hp 3/4hp	1hp 1hp 2hp	1hp 1hp 2hp	1hp 1hp 2hp	1hp 1hp 2hp	1hp 1 1/2hp 2hp	1hp 1 1/2hp 2hp		3hp 3hp 5hp	3hp 3hp 5hp
10.0A 12.0A 12.5A	10.0A 12.0A 12.5A	84.0A 100.8A 105.0A	1hp 1 1/2hp 1 1/2hp	1hp 1 1/2hp 1 1/2hp	2hp 3hp 3hp	2hp 3hp 3hp	2hp 3hp 3hp	2hp 3hp 3hp	3hp 3hp 3hp	3hp 3hp 3hp		5hp 7 1/2hp 7 1/2hp	5hp 7 1/2hp 7 1/2hp
13.0A 15.0A 16.0A	13.0A 15.0A 16.0A	109.2A 126.0A 134.4A	1 1/2hp 2hp 2hp	1 1/2hp 2hp 2hp	3hp 3hp 3hp	3hp 3hp 3hp	3hp 3hp 3hp	3hp 3hp 3hp	3hp 3hp 5hp	3hp 3hp 5hp		7 1/2hp 10hp 10hp	7 1/2hp 10hp 10hp
20.0A 25.0A	20.0A 25.0A	168.0A 210.0A	3hp 3hp	3hp 3hp	5hp 5hp	5hp 5hp	5hp 7 1/2hp	5hp 7 1/2hp	5hp 7 1/2hp	5hp 7 1/2hp		10hp 15hp	10hp 15hp
30.0A	30.0A	252.0A	5hp	5hp	5hp	5hp	7 1/2hp	7 1/2hp	10hp	10hp		20hp	20hp
32.0A	32.0A	268.8A	5hp	5hp	5hp	5hp	10hp	10hp	10hp	10hp		20hp	20hp
40.0A	40.0A	226.0A	5hp	5hp	10hp	7 1/2hp	10hp	7 1/2hp	10hp	10hp		30hp	20hp
50.0A 60.0A	50.0A 60.0A	282.5A 339.0A	7 1/2hp 10hp	7 1/2hp 10hp	15hp 15hp	10hp 10hp	15hp 20hp	10hp 10hp	15hp 20hp	10hp 15hp		30hp 40hp	25hp 30hp

NOTE #1: For AC motor circuit nameplate full load current, AC general-use loads, AC resistance loads, AC incandescent lamp (tungsten) loads, AC electric discharge lamp (ballast) loads.
NOTE #2: Conversions per UL508® proposed Tables 45.2 and 45.4 and NFPA-70: National Electrical Code® 1999 Tables 430-149, 430-150 and 430-151B.

V-EA INTERNAL RESISTANCE

Rated Current (Amp)	Trip Characteristic					
	B (Ohms)	C (Ohms)	D (Ohms)	E (Ohms)	G (Ohms)	Z (Ohms)
0.3	—	16.8620	16.8620	14.52000	16.8620	31.5060
0.5	—	6.8540	6.0009	5.92000	6.8540	10.2460
0.75/0.8	—	3.0540	3.0540	2.70000	3.0540	5.3920
1.0	—	1.7000	1.7560	1.48000	1.7560	2.6910
1.6	—	0.5870	0.5870	0.57400	0.5870	0.9440
2.0	—	0.4190	0.4190	0.40500	0.4190	0.8900
2.5	—	0.2950	0.2950	0.26900	0.2950	0.4290
3.0	—	0.2020	0.2020	0.18600	0.2020	0.3460
3.5	—	0.1390	0.1390	0.13900	0.1390	0.1790
4.0	—	0.1090	0.1090	0.10600	0.1090	0.1620
5.0	—	0.0654	0.0654	0.05900	0.0654	0.1050
6.0	0.0528	0.0528	0.0491	0.04600	0.0491	0.0823
8.0	—	0.0278	0.0240	0.03040	0.0333	0.0371
10	0.0216	0.0216	0.0187	0.02020	0.0211	0.0278
12/12.5	—	—	—	0.00724	0.0084	0.0151
13	0.0113	0.0084	0.0085	0.00724	0.0084	0.0151
15/16	0.0085	0.0085	0.0076	0.00731	0.0076	0.0114
20	0.0067	0.0067	0.0064	0.00582	0.0064	0.0075
25	0.0050	0.0050	0.0041	0.00411	0.0046	0.0050
30/32	0.0032	0.0032	0.0027	0.00272	0.0030	0.0032
40	0.0025	0.0025	0.0022	0.00212	0.0022	—
50	0.0019	0.0019	0.0018	0.00184	0.0019	—
60/63	0.0018	0.0018	0.0017	0.00172	0.00179	—

Resistances listed are “hot” values, as opposed to cold start values. Operating voltage drop across the V-EA and power loss per pole can be approximated with basic formulas:

$$V_{DROP} = I_{OPERATING} \times R_{TABLE}$$

$$P_{LOSS P/P} = I_{OPERATING}^2 \times R_{TABLE}$$

Voltage drops should be reviewed when V-EAs with high internal resistance are used (e.g., load voltage minimums). Power loss should be reviewed when V-EAs with high rated currents are used (e.g., enclosure heating).

The listed V-EA internal resistance values should not be used in calculations of available short-circuit current downstream of the V-EA. The dynamic impedance of the V-EA under short-circuit conditions can vary significantly from internal resistance values in normal operation.

LINE CURRENT FREQUENCY EFFECTS ON TRIP CURVES

Frequency Effects on Magnetic Trip Curves					
Trip Curve	Trip Zone At	Trip Zone At	Trip Zone At	Trip Zone At	Trip Zone At
	16 2/3 - 60Hz (x RC)	100 Hz (x RC)	200 Hz (x RC)	400 Hz (x RC)	DC (x RC)
Z	2 - 3	2.2 - 3.3	2.4 - 3.6	2.8 - 4.2	3.0 - 4.5
B	3 - 5	3.3 - 5.5	3.6 - 6.0	4.2 - 7.0	4.5 - 7.5
C	5 - 10	5.5 - 11.0	6.0 - 12	7.0 - 14.0	7.5 - 15.0
G	8 - 10	8.8 - 11.0	9.6 - 12.0	11.2 - 14.0	12.0 - 15.0
D	10 - 16	11.0 - 17.6	12.0 - 19.2	14.0 - 22.4	15.0 - 24.0
E	14 - 18	15.4 - 19.8	16.8 - 21.6	19.6 - 25.2	21.0 - 27.0

The thermal trip is not affected by the frequency of the line current. The magnetic trip is within the trip zone of the characteristic curve for frequencies from 16 2/3 to 60Hz. At lower and higher frequencies, the magnetic trip will be delayed longer than indicated by the characteristic curve, roughly as follows:

At 100Hz: Mag. Trip Current = 1.1 x curve current

At 200Hz: Mag. Trip Current = 1.2 x curve current

At 400Hz: Mag. Trip Current = 1.4 x curve current

At DC: Mag. Trip Current = 1.5 x curve current

For example, at 16 2/3 - 60 Hz the magnetic trip zone for the “G” characteristic is 8 to 10 times the rated current of the specific V-EA (i.e., hold for at least 100ms at 8 x RC, trip in less than 100ms at 10 x RC). With a 400Hz current, a magnetic trip at 10 x RC would be greatly delayed (thermal would likely trip first), as the magnetic trip zone is now 11.2 to 14 x RC. If a quicker magnetic trip is required with 400Hz, the “B” or “C” characteristic should be considered.

MECHANICAL ENDURANCE RATINGS (ON/OFF OPERATIONS)

Application	2 x (1.15 x RC)	2 x RC	RC	No Load	Total
AC General Use	—	6000	—	4000	10000
AC Motor Starting Across the Line	1000	—	5000	4000	10000
AC Incandescent Lamps (Tungsten)	—	—	6000	4000	10000
AC Electrical Discharge Lamps (Ballast)	—	6000	—	4000	10000
AC Resistance	—	6000	—	4000	10000

Manufacturers self certification	20000 ON/OFF operations with no load
---	--------------------------------------

SHORT CIRCUIT RATINGS FOR V-EA MANUAL MOTOR CONTROLLER

Trip Curve	Amp Range	Backup Protection	UL-Listed RK5-Fuse up to 10kA	UL-Listed MCCB up to 10kA	No BCP Required up to:
all	0.3 - 10A		4xRC* min 15A, max 70A	4xRC* min 15A, max 70A	10kA
all	12 - 30/32A		4xRC* max 125A	4xRC* max 125A	5kA
all	40 - 50A		4xRC* max 200A	4xRC* max 200A	5kA
all	60 / 63A		4xRC* max 250A	4xRC* max 250A	5kA

*up to nearest rated current

TEMPERATURE CORRECTION CURVE

Ambient Temperature and Adjacent Mounting/Loading Adjustment

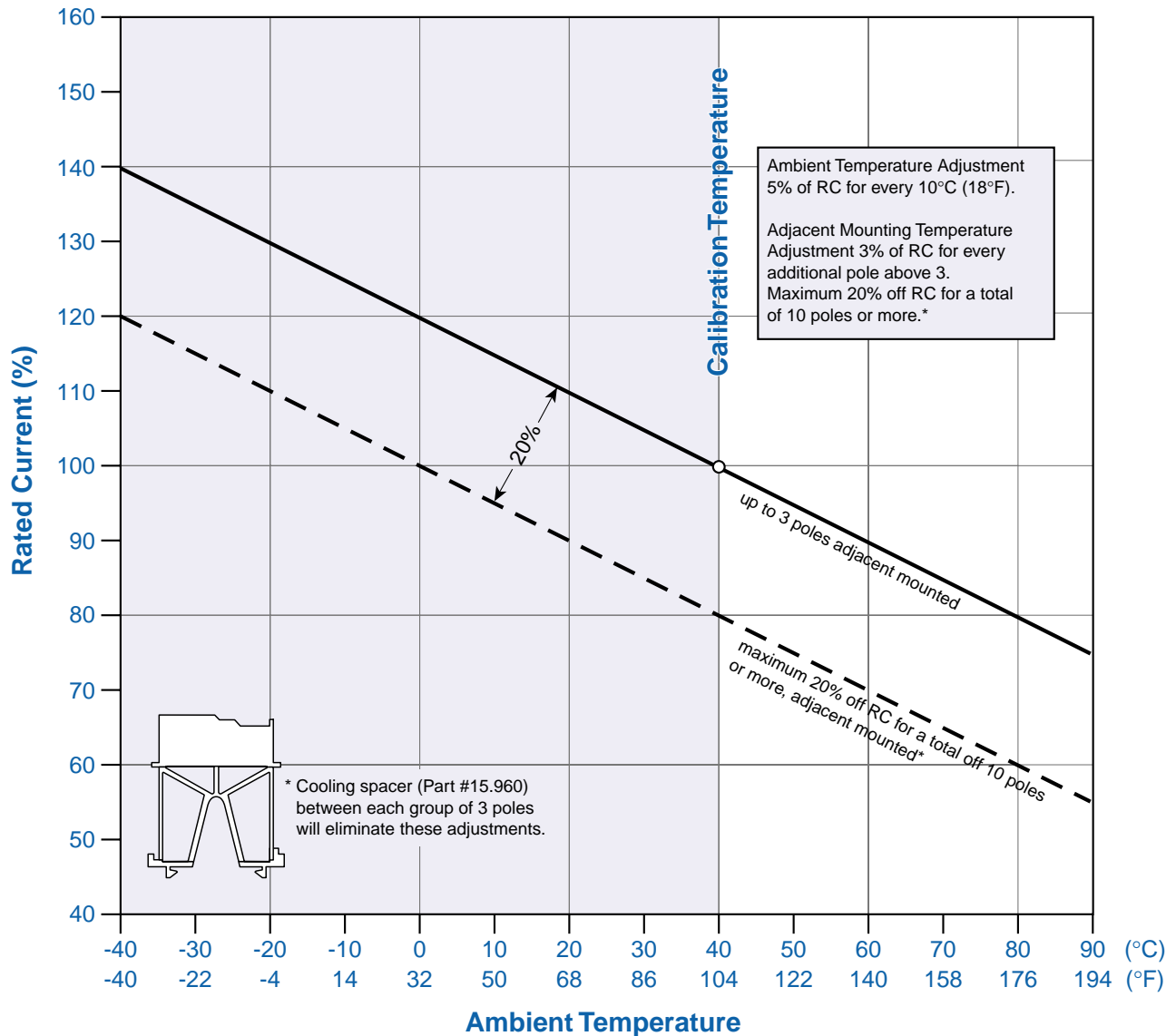

CUT-AWAY VIEWS OF V-EA MINIATURE CIRCUIT BREAKER

Shown in “on” position

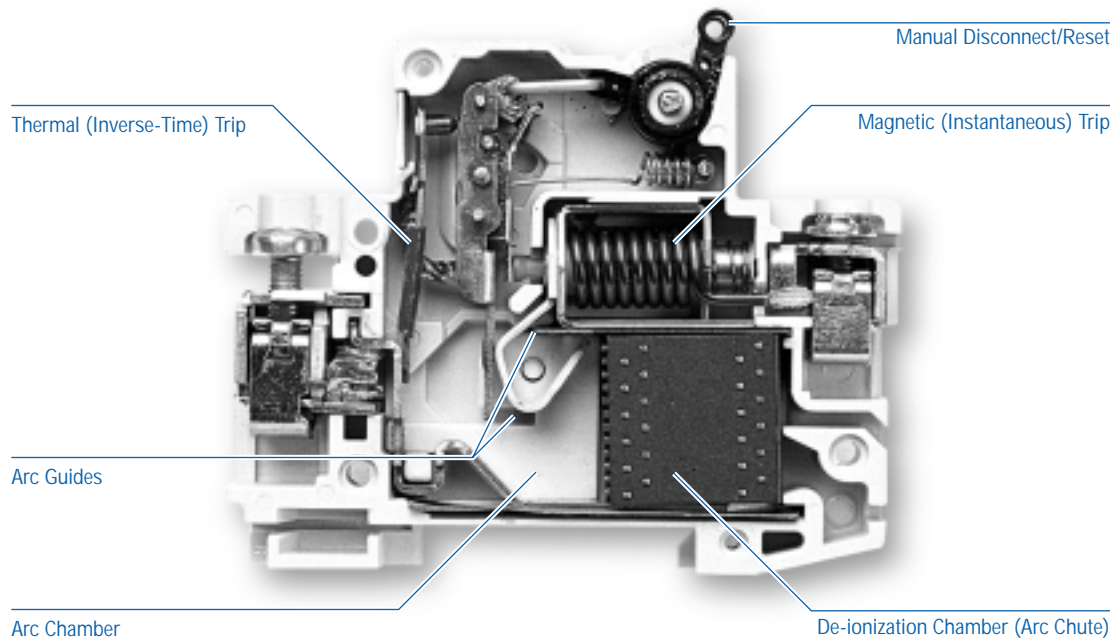

Shown in “off” position

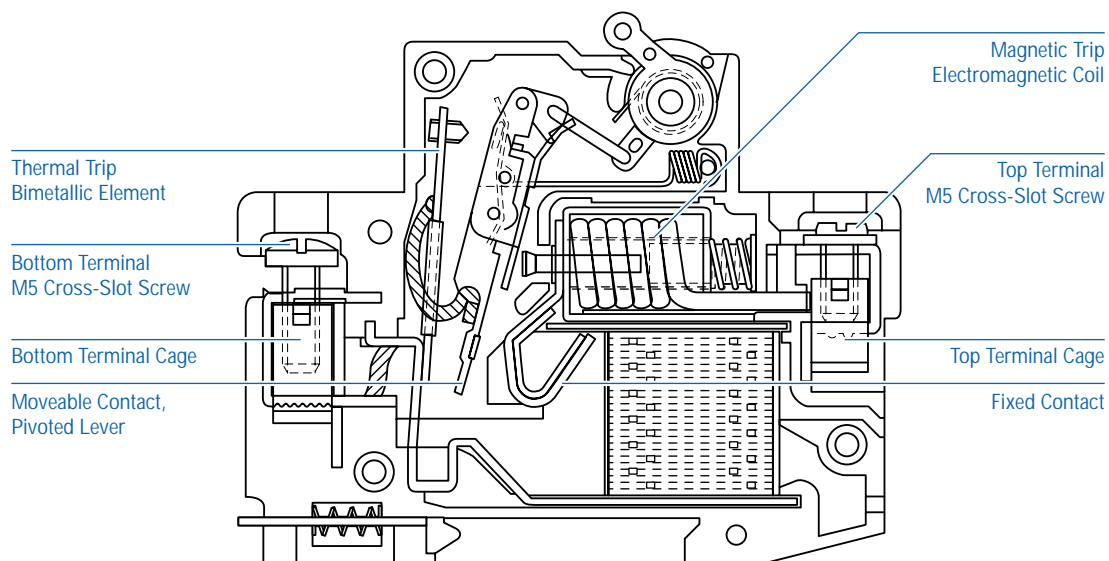

INSTALLATION RECOMMENDATIONS

INTRODUCTION

The V-EA* easily snaps onto a readily available, international standard 35mm DIN Rail. Mounting can be in any position from full horizontal to full vertical without affecting performance.

All housings are the same size regardless of rated current, simplifying layout and modifications.

Line power feed can be to either top or bottom terminals. This provides flexibility to power distribution enclosure entry (top, bottom, sides) and internal raceway runs (e.g., power in one horizontal raceway can feed both the row above and the row below).

Minimal free space is required to remove or replace the V-EAs, and with standard housing and terminal sizes, ratings can be changed or multi-poles can replace multi-single pole or vice-versa. To obtain the highest density mounting arrangement without serious problems from heat build-up, see "Temperature Correction Curve" (page 22).

Altech and our distributors are pleased to quote custom rail assemblies. Multi-function assemblies can include cut-to-order DIN Rail, mounted V-EA and MA circuit breakers, FI Earth Leakage breakers, lightning/surge protectors, interface modules (cable fan-out, relays, I/O, power supply, etc.), terminal blocks with marking tags, and other control components to meet your specifications. Order assemblies with only one part number or even your drawing number.

DIN Rail Information

Mounting rails are internationally standardized and are available in several sizes with or without perforations. Zinc-plated yellow chromated steel is standard. Copper and aluminum DIN Rails are also available. Please contact Altech for your DIN Rail needs.

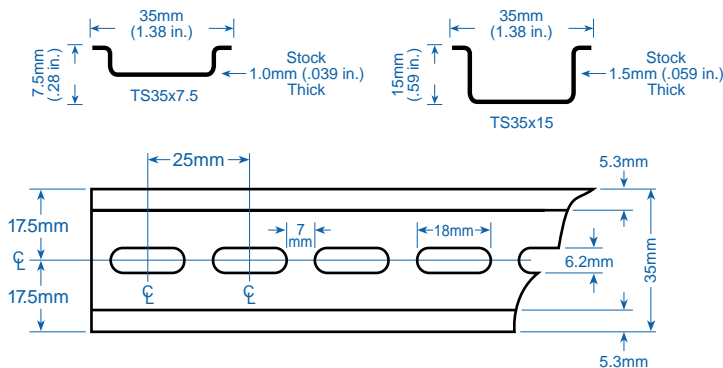

TS35 DIN Rail Perforations Dimensions $\pm 0.1\text{mm}$ (.003 in.)

SNAP-ON MOUNTING

1. Place the upper lip of the V-EA* under the upper lip of the rail.
2. Press down on bottom terminal area until the V-EA* spring-loaded clip snaps under lower lip of the rail.



* V-EA miniature circuit breaker handling is representative for MA circuit breakers and FI Earth Leakage circuit breakers.

EASY REMOVAL

Removal, One Pole

1. Insert tip of 4mm or less straight blade screwdriver into the slot of the metal retaining clip.
2. Brace the shank of the screwdriver against the terminal side of the V-EA* and gently lever the clip away from the DIN rail.
3. When the clip moves out, continue rotating screwdriver and V-EA* up and off of the bottom of the DIN rail lip.
4. Grasp V-EA* and lift upwards to disengage from the top lip of the rail, then remove.

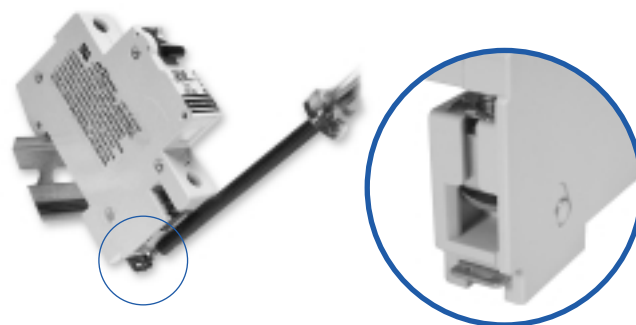

WIRING

- Field wiring terminal size acceptability:
Top: 18-3 AWG
Bottom: 18-2 AWG
- Use 75°C insulation copper conductors only, loaded to 60°C ampacity.
- Wire conductor stripping length:
Top Terminals: 11.5mm (approximately 7/16")
Bottom Terminals: 12.5mm (approximately 1/2")
- For terminal screws, we recommend a #2 Phillips or Posidriv screwdriver. Terminals are also readily accessible to battery operated screwdrivers. Please contact Altech for tool and ordering information.
- Terminal tightening torque is rule-of-thumb 20 lb.in.



V-EA DIMENSIONS

General

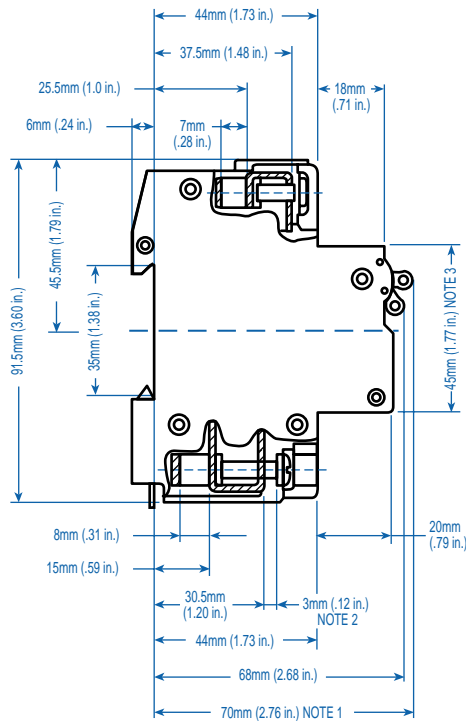

Mounting in Enclosure

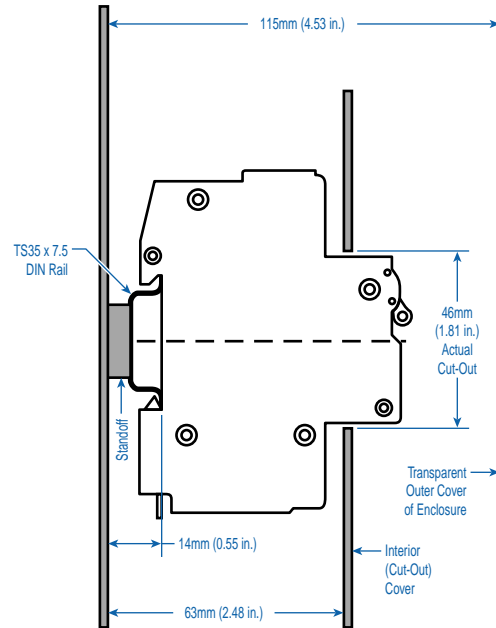

For note information see section below.

Not Shown: Width of Face (Thickness)
 One Pole 17.5mm (.69 in.)
 Two Pole 35mm (1.38 in.)
 Three Pole 52.5mm (2.07 in.)

ALTECH/SPELSBERG EK/AK NONMETALLIC ENCLOSURES FOR MCBS

NOTE 1: For totally enclosing the V-EA, the minimum interior depth of the enclosure is 70mm plus DIN Rail depth (7.5 or 15mm) plus any rail mounting stand-off depth.

NOTE 2: Fork lugs with a thickness up to 3mm can be inserted in the lower terminals under the head of the captive M5 (i.e. 5mm diameter to outside of threads) terminal screw.

NOTE 3A: The V-EA's raised face is sized to fit through standard European enclosure cut-outs, which allow sight and operation of the trip/reset handle but keep all wiring covered. As shown in Fig. 1, Altech/Spelsberg AK/EK nonmetallic enclosures are ready-made for this attractive and efficient packaging approach.

NOTE 3B: The V-EA was successfully short-circuit tested in TYPE 1 metal enclosures with the V-EA face extending through a 46mm cut-out in the cover. Typical applications include:

- V-EA on 35mm wide by 15mm deep DIN Rail, mounted to back wall of a 3 inch deep enclosure with no back panel.
- V-EA on 35mm wide by 7.5mm deep DIN Rail, mounted to the back panel of a 3 inch deep enclosure with panel.

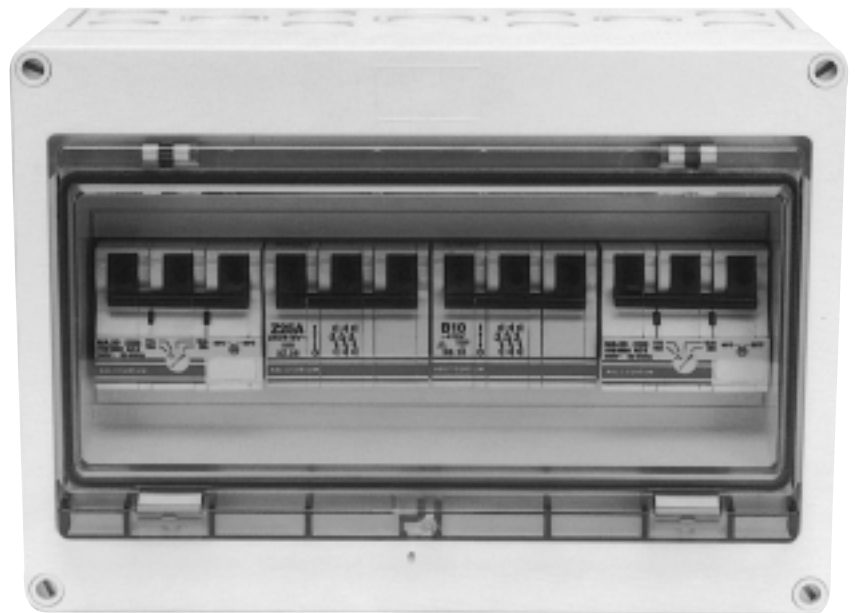

Fig 1. Altech/Spelsberg EK/AK nonmetallic enclosure with Altech/ABL Sursum V-EA and MA Circuit Breakers installed.

MA Three Phase Adjustable Trip Miniature Circuit Breakers/ Manual Motor Controllers



UL508 listed



CAN/CSA-C22.2 No.14 certified



The MA was designed to handle the high inrush loads of 3 phase transformers, power supplies, motors, etc. The MA protects wiring and equipment from damage caused by the three major classes of over-current, yet greatly reduces the number of nuisance trips in high starting and inrush current circuits.

An IEC device with excellent ratings under a UL listing at 480Y/277V (including group ratings) and at 500V under international standards, the Altech/ Sursum MA provides short and long term cost effective circuit protection for USA and/or export applications. The short term advantages include: (1) adjustable thermal trip allows finalization of initial designs before procurement of the load equipment is complete; (2) snap-on mounting for readily available, internationally standardized DIN Rail saves panel layout design time as well as installation and change labor; (3) large cage-clamp terminals with screws suitable to power screwdrivers, simplifies and speeds wiring; (4) convenient switched disconnect during factory testing and/or initial start-up saves time and aggravation. The key long term advantage is customer satisfaction and proven over-current protection of wiring and equipment (and the lack of rework/repair costs).

Type Designation

MA RT
(a) (b) (c) (d)

- (a) = MA - Manual Motor Controller
- (b) = Rated Current
- (c) = U - US Housing
- (d) = Blank - Standard Terminal
RT - Ring-tongue Terminal

Voltage Rating	480Y/277VAC
AIC (Interrupt Capacity)	0.16A-2.5A: 42kA; 4.0A-16A: 14kA; 20A-40A: 10kA
Standard Short Circuit Withstand Rating (UL/CSA Ratings)	0.16A-2.5A: 42kA; 4.0A-16A: 14kA
Group Short Circuit Ratings (UL/CSA Ratings)	see above
Typical Life	6000 on/off operations with 2xRC
Calibration Temperature	25°C, +0°, -5° (77°F, +0° -9°)
Standard Pack and Weight	1/450g (1.0 lb.)
Terminal Size Acceptability	Top/Bottom: 18-3 AWG

Type and Rated Current	Cat. No.	FLA Dial Adjustment Markings	GROUP SHORT CIRCUIT RATING AT 480VAC ^a (and BCP size)	3Ø HORSEPOWER RATINGS AT NOMINAL LINE VOLTAGE (See Note for HEA Definition)				
				110-120V HP (HEA)	200V HP (HEA)	208V HP (HEA)	220-240V HP (HEA)	460-480V HP (HEA)
MA0.16U	15.901U	0.1/ 0.12/0.14/0.16	42kARMS symmetrical (max. 1200A MCCB or RK5)					
MA0.25U	15.902U	0.16/0.19/0.22/0.25						
MA0.40U	15.903U	0.25/0.30/0.35/0.40						
MA0.63U	15.904U	0.40/0.48/0.56/0.63						
MA1.0U	15.905U	0.63/0.75/0.87/1.0						
MA1.6U	15.906U	1.0/1.2/1.4/1.6						
MA2.5U	15.907U	1.6/1.9/2.2/2.5	14kARMS symmetrical (max. 350A MCCB or RK5)					
MA4.0U	15.908U	2.5/3.0/3.5/4.0		1/2 (4.0)	3/4 (3.2)	3/4 (3.1)	1 (3.6)	2 (3.42)
MA6.3U	15.909U	4.0/4.8/5.6/6.3		3/4 (5.6)	1 1/2 (6.0)	1 1/2 (5.7)	1 1/2 (5.2)	3 (4.8)
MA10U	15.910U	6.3/7.5/8.7/10		1 (7.2)	2 (7.8)	2 (7.5)	3 (9.6)	5 (7.6)
MA16U	15.911U	10/12/14/16		2 (13.6)	3 (11.0)	3 (10.6)	5 (15.2)	10 (14.0)
MA20U	15.912U	16/17/18.5/20		3 (19.2)	5 (17.5)	5 (16.7)	5 (15.2)	10 (14.0)
MA25U	15.913U	20/21.5/23/25		3 (19.2)	5 (17.5)	7 1/2 (24.2)	7 1/2 (22.0)	15 (21.0)
MA32U	15.914U	25/27/30/32		5 (30.4)	7 1/2 (25.0)	7 1/2 (24.2)	10 (28.0)	20 (27.0)
MA40U	15.915U	32/34/37/40		5 (30.4)	10 (32.0)	10 (31.0)	10 (28.0)	25 (34.0)

Note: **HEA - Horsepower Equivalent Amperes**, the nominal amperage assigned to standard motor horsepower ratings in design guide tables such as NFPA-70 Tables 430-148, 430-149, 430-150; UL1077 Table 16.2; CSA - C22.2 No. 235-M89 Tables 44 and 45; CSA-C22.2 No. 14-M91 Table 19, etc. Multiply HEA values (in parenthesis) by 1.1 if power factor is 90%, and by 1.2 if power factor is 80%.

^a The standard-circuit short-circuit rating is 14kA for all types. Group ratings can be used in a standard circuit (e.g., MA1.0U at 42kA), but a higher standard rating cannot be used in a group circuit (e.g., MA40U at 14kA only in standard circuit.)

DIMENSIONS

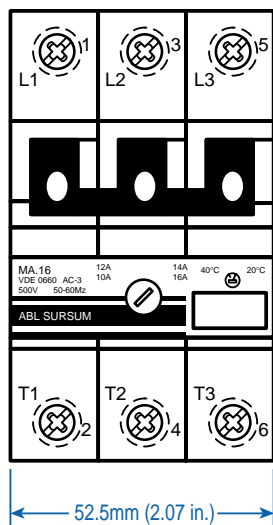
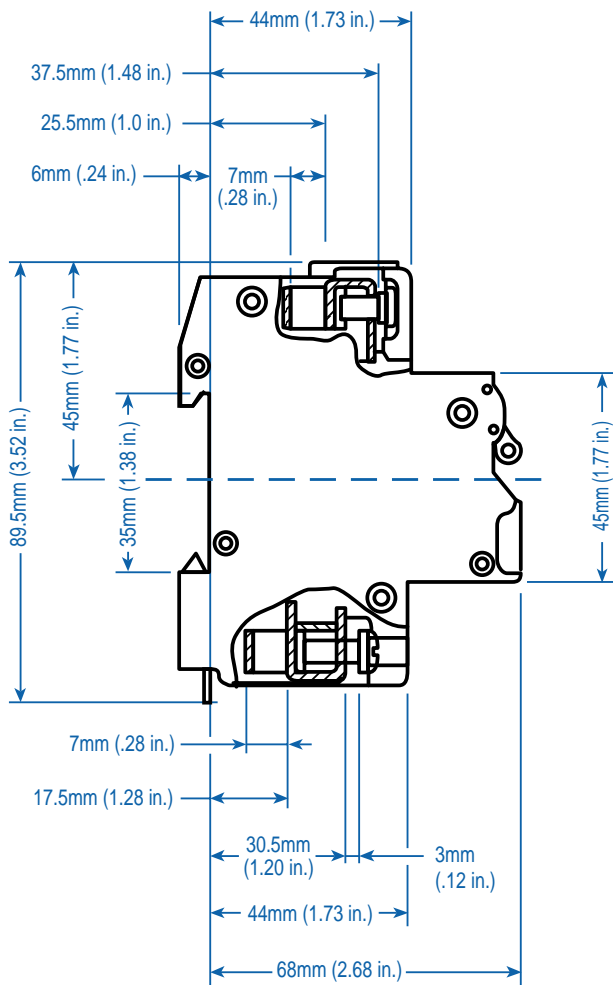

TRIP CHARACTERISTICS MAU

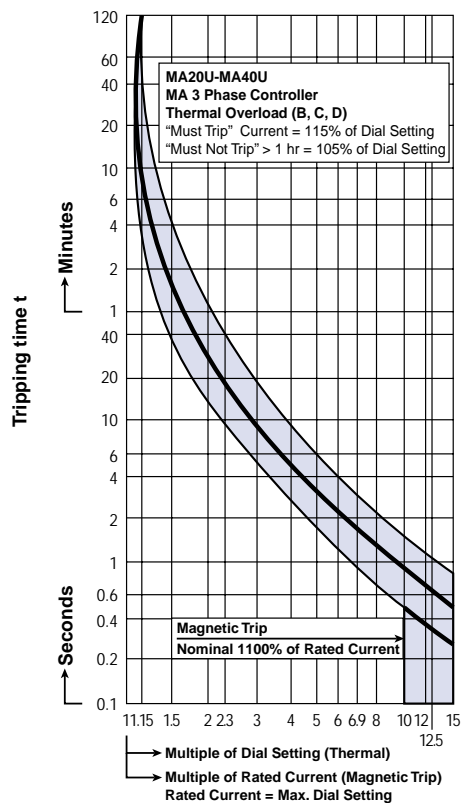
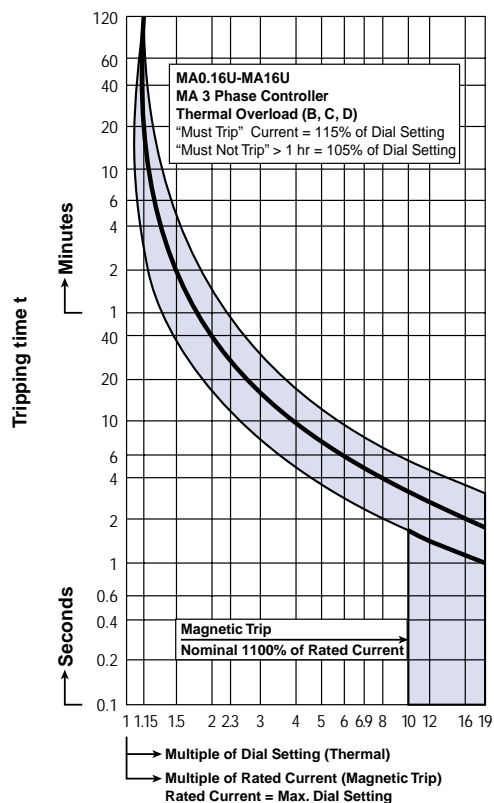

MA/USA Manual Motor Controller

MS Three Phase Adjustable Trip Economy Manual Motor Controllers

with overload and short circuit protection,
phase failure sensitivity according to
IEC 947-4-1, DIN VDE 0660 Part 102

Due to its high breaking capacity with high current limitation the MS Manual Motor Controllers provide an optimum of protection for electrical motors as well as for other consumer units up to 25 amps. They are equipped with phase failure sensitivity, isolating and main switch functions; 13 ranges are covering nominal rated currents from 0.1 up to 25 amps.

The MS's are temperature compensated; the trip current of the magnetic part is $12 \times I_n$. The Manual Motor Controllers are built in accordance with IEC 947.



Type Designation

MS 016

(a) (b)

(a) = MS - Manual Motor Controller

(b) = Rated Current

Type/ Cat. No.	Rated Current	Overload release adjustment/FLA (A)	Instantaneous setting (A)	3Ø Horsepower Rating									
				115V	200V	230V	480V	600V					
MS016	0.16	0.1 - 0.16	1.92	Ampere rated for motor circuits having a full-load-amperage (FLA) not exceeding the MS's general purpose rated current and a locked rotor current not exceeding 6 times the MS's rated current.									
MS025	0.25	0.16 - 0.25	3										
MS04	0.4	0.25 - 0.4	4.8										
MS063	0.63	0.4 - 0.63	7.6										
MS1	1.0	0.63 - 1	12										
MS1.6	1.6	1 - 16	19.2										
MS2.5	2.5	1.6 - 2.5	30						1/2hp	1/2hp	1hp	11/2hp	
MS4	4.0	2.5 - 4	48						1/2hp	3/4hp	1hp	2hp	3hp
MS6.3	6.3	4 - 6.3	75.6						3/4hp	11/2hp	11/2hp	3hp	5hp
MS10	10.0	6.3 - 10	120						1hp	2hp	3hp	5hp	71/2hp
MS16	16.0	10 - 16	192	2hp	3hp	5hp	10hp	10hp					
MS20	20.0	16 - 20	240	3hp	5hp	71/2hp	15hp	-					
MS25	25.0	20 - 25	300	3hp	5hp	71/2hp	15hp	-					

Maximum Voltage	600V AC (MS20 and MS25, 480V AC)
Interrupting Capacity (UL/CSA Rating)	5kA
Group Short Circuit (UL/CSA - Ratings)	5kA
Interrupting Capacity (VDE - Ratings)	0.16-6.3A: Self protected 10-25A: 6kA
Mechanical Endurance	10000 on/off operations
Standard Pack and Weight	1/250g (0.55lb)
Terminal Size Acceptability	14-10AWG
Terminal Torque	1.8Nm (16lb. in.)

Dimensions

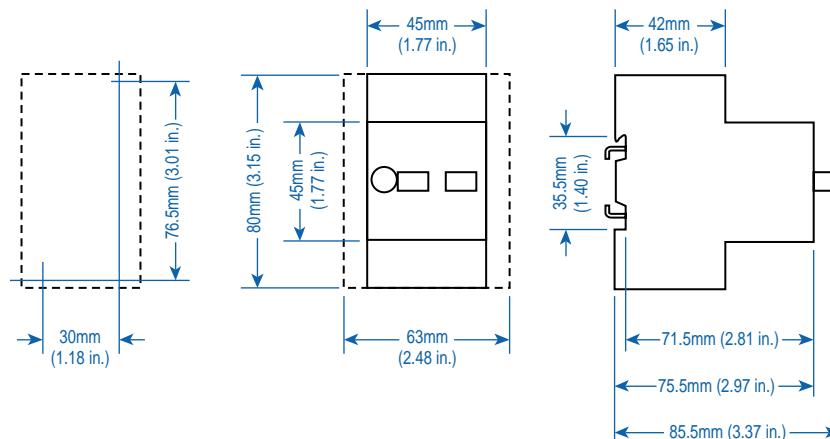

Accessories

MS Three Phase Adjustable Trip Economy Manual Motor Controllers

Auxiliary contact blocks for side mounting (3.5A/230VAC; 2A/400V AC)



Width mm	Contacts	Type/ Cat. No.	Weight	Std. Pk.
9	2NO	HMS20	40	10
9	1NO + 1NC	HMS11	40	10
9	1NO	HMS10	35	10
9	2NC	HMS02	40	10
9	1NC	HMS01	35	10



Insulated Enclosure IP 55
with integrated PE(N) terminal top and bottom each 2 metric knock-outs

Type/ Cat. No.	Weight g/pc.	Std. Pk.
MS.G55	240	1



Emergency-Stop
twist or key to release, red on yellow background

Release Type	Type/ Cat. No.	Weight g/pc.	Std. Pk.
Twist	MS.PV	60	5
Key	MS.PS2	65	5



Flush Mounting Enclosure IP55
with integrated PE(N) terminal

Type/ Cat. No.	Weight g/pc.	Std. Pk.
MS.F55	170	1



Indicator Light
with neon bulb, nominal rated voltage: 220 - 240V or 380 - 440V

Color	Type/ Cat. No.	Weight g/pc.	Std. Pk.
		220-240V	380-440V
trans	MS.SLW2	MS.SLW3	10 5
green	MS.SLG2	MS.SLG3	10 5
red	MS.SLR2	MS.SLR3	10 5
yellow	MS.SLJ2	MS.SLJ3	10 5

Busbar



Busbar 63A	Type/Cat. No.			
	for 2 MS	for 3 MS	for 4 MS	for 5 MS
no spacing	G45-14-2	G45-14-3	G45-14-4	G45-14-5

with auxiliary switch (1/2 pole) spacing	G54-14-2	G54-14-3	G54-14-4	G54-14-5
--	----------	----------	----------	----------



Power Feed Block

Type/ Cat. No.	Rating (A)	Std. Pk.
GE2-14	63A	1

FI Earth Leakage Circuit Breakers

FI compact Earth Leakage Circuit Breakers detect and interrupt earth (ground) faults. They are VDE approved for the European system of protecting people, animals, equipment and property from dangerous line-to-ground and shock hazard currents.

US applications include ground-fault protection of equipment (GFPE) using the 10mA and 30mA fault current ratings, especially when high distributed capacitance or other leakages cause excessive nuisance trips at lower fault currents. Applications for the 300mA rating are equipment protection and fire prevention, limiting the energy of a fault to less than the minimum ignition energy for many materials.

Type Designation

FI (a) (b) • (c)

- (a) = 2-2 pole; 4-4 pole
- (b) = 1-16A; 2-25A; 3-40A; 4-63A
- (c) = 01 - 10mA
= 03 - 30mA
= 30 - 300mA



FI 2



FI 4^a

Maximum Rated Line Current	Fault Trip Current	Type	Cat. No.		Fault Trip Current	Type	Cat. No.	
16A	10mA	FI 21.01	15.921					
25A	30mA	FI 22.03	15.922		30mA	FI 42.03	15.926	
25A	300mA	FI 22.30	15.924		300mA	FI 42.30	15.929	
40A	30mA	FI 23.03	15.923		30mA	FI 43.03	15.927	
40A	300mA	FI 23.30	15.925		300mA	FI 43.30	15.930	
63A					30mA	FI 44.03	15.928	
63A					300mA	FI 44.30	15.931	
Earth Leakage Circuit Breaker with Auxiliary Contacts^b					Earth Leakage Circuit Breaker with Auxiliary Contacts^b			
25A	30mA	FI 22.03Y	15.932		30mA	FI 42.03Y	15.933	
40A	30mA	FI 23.03Y	15.934		30mA	FI 43.03Y	15.935	
63A					30mA	FI 44.03Y	15.936	

Voltage Rating (maximum)	240VAC, 50/60Hz (VDE: 125/220VAC, 50Hz)	415VAC, 50/60Hz (400Hz available on request) (VDE: 220/380VAC, 50Hz)
Short Circuit Capacity	Up to rated current (RC) 40A = 1.5kA, RC 63A = 2kA. 10kA in combination with series fuse of European Operation Class gL/gG: RC 16A = 63A fuse, RC 20/40A = 80A fuse, RC 63A = 100A fuse.	
Fault Trip Current Calibration	FI trips are calibrated at less than fault trip current for ensured safety (Typical trip range between 66.6-83.3% fault trip current, e.g., typical trip at 20-25mA for fault RC of 30mA)	
Typical Life	Fully functional after 4,000 operations to DIN/VDE 0664 (CEE27) and 16000 additional fault current trips.	
Standard Pack and Weight	1/290g (0.64 lb.); 1/390g (0.86 lb.) with auxiliary contact	1/450g (1.0 lb.) 1/550g (1.21 lb.) with auxiliary contact
Terminal Size Acceptability	16-6 AWG	14-3 AWG
Equivalent Circuit		

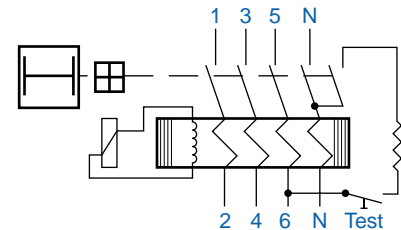
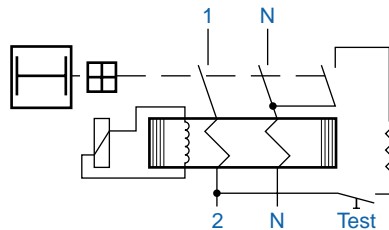

^a For 2-Phase applications, terminal 5 and 6 (next to Neutral terminals) must be connected to one phase for the test circuit to be operable.

^b Provided with mounted Auxiliary Switch, one N.O., one N.C. isolated feedthrough contact (Form X double make and Y double break), which adds 9mm (.35 in.) to the width dimension.

Note: If the power system has a marked conductor, it must connect through the FI and not be grounded at any point downstream.

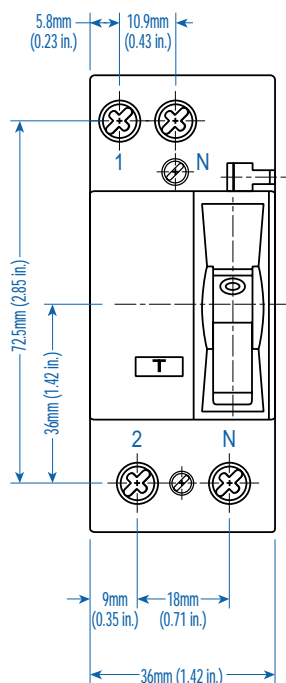

FI 2

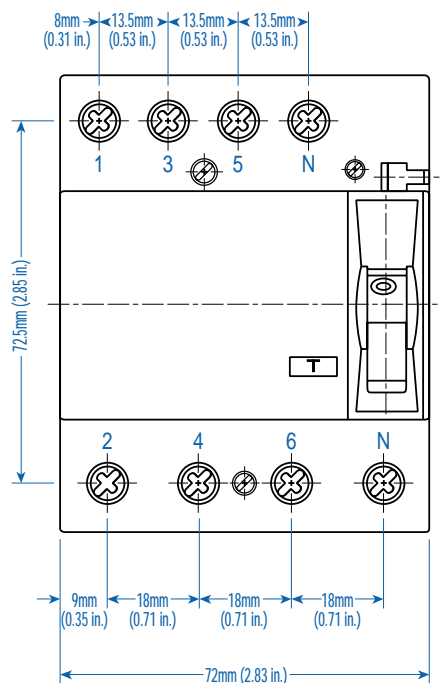

FI 4

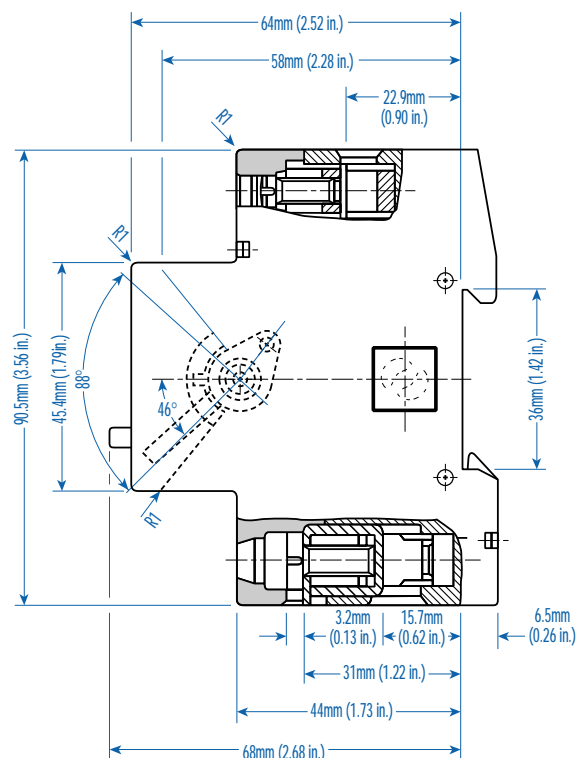

FI 2 and FI 4

Temperature Range	Environmental Information marked with "Snowflake" approval for -25°C to 40°C (-13°F to 104°F) ambient temperature. (Temperature effect on RC: for every 10°C temperature rise above 40°C decrease RC by 7%.)
Fluctuating Climate Conditions	To maximum 45°C, 95% relative humidity.
Electrical Shock Protection	Uninsulated electrically live parts within 30mm of the operating handle are "finger safe" (terminal screw heads) and uninsulated live parts within 100mm of the operating handle are "back-of-hand safe" (terminals).
Impact/Shock Protection	15g with impact force half-cycle sinusoidal and 11ms duration, 18 impacts total with 6 on each principal axis (3 impacts each face). FI is DIN Rail mounted during the test, and electrically loaded with 25% of Fault RC. Successful testing required no trip during the test, no damage and no loosened parts.
Vibration/Seismic Resistance	5g, at frequency of 55Hz to 2,000Hz, applied for 35 ± 5 minutes along each of the three principal axes, plus 5 minutes of application at every established critical resonant frequency. FI is DIN Rail mounted during the test, and loaded with 25% Fault RC. To pass, the FI did not trip at 25% Fault RC, but did trip between each of the principal axis tests when the fault current was raised to 125% Fault RC, and there was no damage and no loosened parts. Suitable for machinery and mobile vehicle applications.
Housing Class	Ingress Protection (IP) Class 40; internal working components and live parts (excluding terminals) are protected against ingress of solid objects greater than 1mm diameter (class 4-), but have no protection from ingress of water (class-0).
Non-Sinusoidal Fault	The FI is tested and approval stamped for tripping sensitivity to non-sinusoidal fault currents, which become zero or almost zero within one cycle of the line frequency. Waveforms and allowed trip-current ranges are as follows: <ul style="list-style-type: none"> 1. AC Sinusoidal Fault - 0.5-1.0 times Fault RC 2a. Pulsating DC Fault; Positive and Negative Half-Waves - 0.35-1.4 times Fault RC 2b. Phased Half-Wave, 90° - 0.25-1.4 times Fault RC Phased Half-Wave, 135° - 0.11-1.4 times Fault RC 3. Pulsating DC on 6mA DC (continuous) Base - Max. 1.4 times Fault RC + 6mA
Insulation Category	At VDE rated voltage, suitable for Class C environments with relatively high dust and moisture levels and little HVAC control, e.g., industrial, commercial, agricultural; on machine tools, hoists, warehouse equipment, etc.; in boiler rooms, unheated storage, covered shipping/receiving, open workshops, etc.

V-EA and MA Circuit Breaker Accessories

Accessories can be factory or field mounted on V-EA miniature circuit breakers and MA motor protection switches for enhanced control and monitoring capabilities. Field mounting kits include all necessary parts and instructions. Accessories can be gang mounted on a single breaker (the Auxiliary Switch in the outside position). The mounting arrangement links the internal latch-pins for the tripping mechanisms, ensuring simultaneous trips. Handles are linked to simplify manual resetting.



FA

Shunt Trip

Type/ Cat. No.	Trip/Coil		
	Voltage AC/DC	Max. Coil Current	Approvals
FA12U	12V	1.3A	UL Ⓢ
FA24U	24V	0.6A	UL Ⓢ
FA48U	48-72V	0.2A	UL Ⓢ
FA110U^a	110V	0.25A	UL Ⓢ
FA110U^a	220V	0.5A	UL Ⓢ
FA110U^a	380VAC	0.8A	UL Ⓢ

Std.Pk.: 1
Unit Weight: 120 grams (0.27 lb.)
Width: 17.5mm (.689in.)

Coil actuated, the FA Shunt Trip allows electrical remote tripping of a breaker. It is trip-free and the housing and terminal specifications are the same as for V-EA miniature circuit breakers. The Shunt Trip contains its own contacts which break the tripping power circuit when tripped. It is available with trip-coils in most standard control voltages. The device is UL and CSA listed for general use.



UA

Undervoltage Trip

Type/ Cat. No.	Line Voltage 60Hz*
UA120	120VAC
UA208	208VAC
UA240	240VAC
UA277	277VAC
UA415	415VAC
UA480	480VAC

Std.Pk.: 1
Unit Weight: 70 grams (0.16 lb.)
Width: 17.5mm (.689in.)

Re-power your system under controlled conditions following a power loss or serious undervoltage. Altech/Sursum UA Undervoltage Trips are coupled to the tripping latch pins of the V-EA or MA to which they are attached, reliably producing trips at the drop-out voltage and preventing resetting when less than 85% line voltage is present. The Undervoltage Trip is provided with at least 6-inch pigtailed of stranded fixture wire for hook-up to the V-EA or MA line terminals.

- Reset-Hold Voltage = 0.85 x Ve
- Drop-Out Voltage = 0.35 to 0.7 x Ve

* Please consult Altech for your 50Hz application needs.

^aOne device with wide voltage range.



H

Auxiliary Switch

Type/ Cat. No.	Approvals	For Use With:
H11U	UL Ⓢ	V-EA, MA
HF111		FI

Std. Pk.: 1
Unit Weight: 45 grams (0.12 lb.)
Width: 9mm (.354in.)

Contact Ratings	
H11U	HF111
10A / 220V AC	6A / 230V AC
3A / 110V DC or pulsed	—
1A / 220V DC or pulsed	1A / 220V DC or pulsed
Wire Size (max.)	
4mm ² (12 AWG)	4mm ² (12 AWG)

Two isolated, feedthrough Form X and Y contacts are provided: one with the same form as the breaker (HS designation, closed auxiliary contacts when breaker is on and breaker contacts are closed); and one with the opposite form as the breaker (HO designation, closed auxiliary contacts when breaker is tripped and breaker contacts are open). Upper level terminals are metal-stamped "HS" and lower level terminals are stamped "HO", providing clear identification for drawings and physical wiring (line/load on either terminal).

Altech/Sursum H Auxiliary Switch is suitable for logic interrogation and for use as a two-circuit Form C contact. It can also function as an auxiliary switch for control circuits. The H11U is UL and CSA listed for general use.



Lock-out ① Cat. No. EASS

Prevent inadvertent resetting of the V-EA or MA during maintenance. Fits 1/4" pad lock.

Ring Tongue Terminals

Available for VE-A and MA series. Please specify when ordering and refer to type designation.

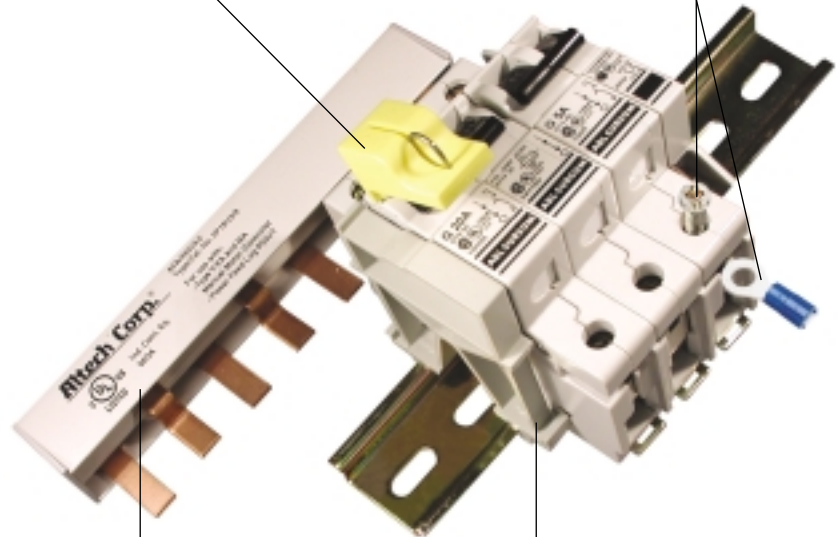

Busbar Systems

Please see pgs. 32-35 for your busbar needs.

Cooling Spacer

Cat. No. 15.960

See also Correction Curve, pg. 22.



- ① V-EA and MA can also be locked in the on and off position by simply using a common lead or meter seal, which gets fed through the hole in the handle and a corresponding hole in the case housing.

Altech Busbar Systems

The Altech Busbar system is an innovative way to jumper up to 57 poles of Altech Miniature Circuit Breakers (MCB)/ Manual Motor Controllers (MMC).

The advantages of this jumper system are:

- Installation time savings
- Panel space savings
- Less or no maintenance
- High electrical ratings
- Customers can cut the busbar without losing the UL approval

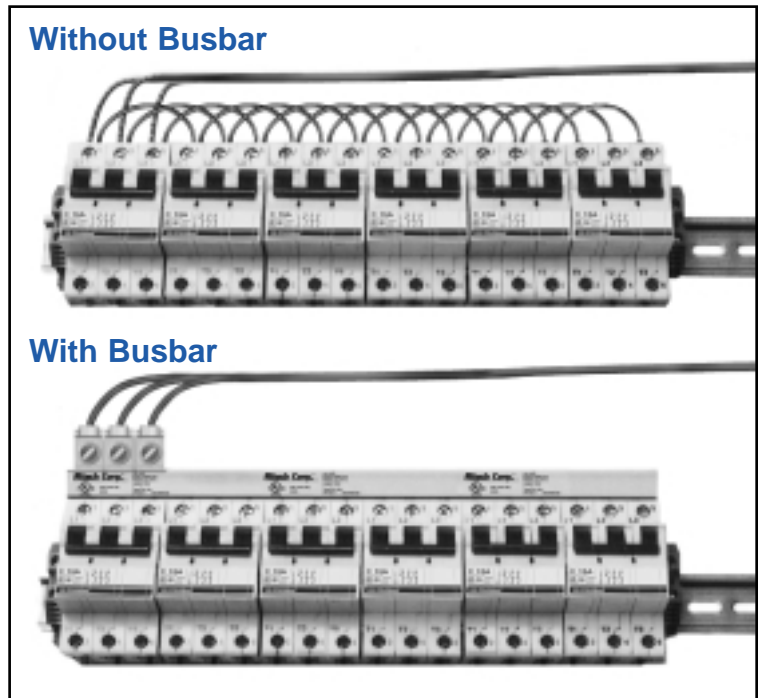

Two Power Feed Methods

START/ END Feed Method

Rated current per phase

	L1	L2	L3
18mm ² :	80A	80A	80A
25mm ² :	100A	100A	100A

CENTER/ MIDDLE Feed Method

Rated current per power feed block

	L1	L2	L3
18mm ² :	160A	160A	160A
25mm ² :	200A	200A	200A

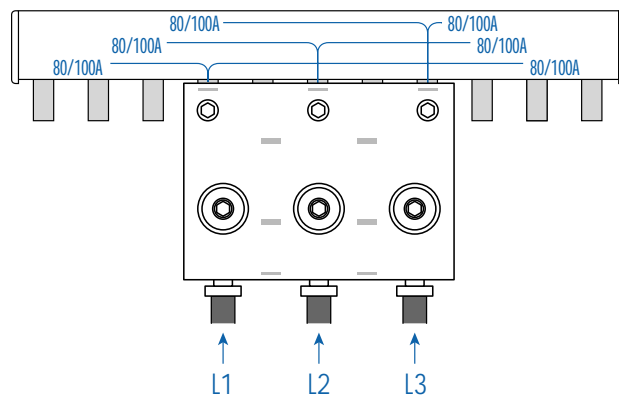
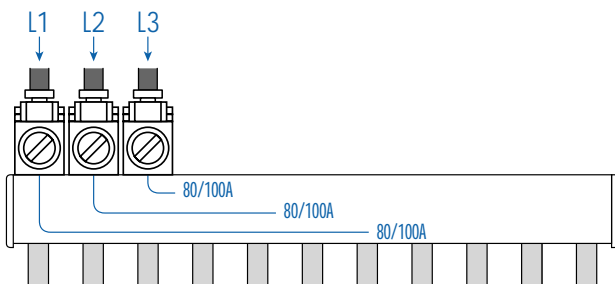

Power Feed Devices

Application examples:

Easy connection of the power supply wires to the busbar/MCB. Power Feed Devices ensures permanent connection.

Type Designation

$\frac{P}{(c)}$ $\frac{50}{(b)}$ $\frac{U}{(c)}$ $\frac{T}{(d)}$

- (a) = Power Feed lug/block
- (b) = 50mm² or 95mm² cross-section area
- (c) = USA and Canadian design basics
- (d) = T-Terminal connection
B-Busbar connection

Power Feed Lug

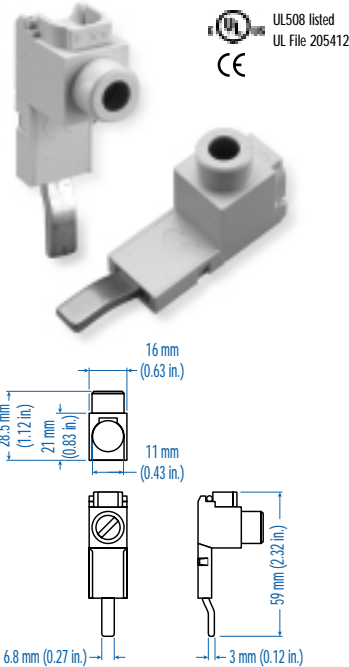

Power Feed Block*

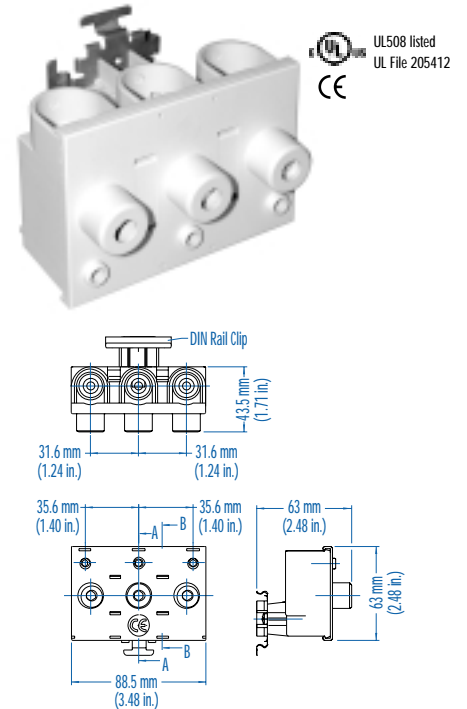

Type/Cat. No.	P50UT	P95UB
Electrical Ratings	115A/480VAC	200A/480VAC
Terminal Site Acceptability	10-1/0 AWG	1-4/0 AWG
Recommended/Required Torque	5.6Nm (50lb. in.)	19.5Nm (175lb. in.)
Material of Lug	MS58 Brass	MS58 Brass
Insulation Material	Zytel FR 72G25-V Plastic	Zytel FR 72G25-V Plastic
For use with	18 and 25mm ² 1-3 phase Busbar	18 and 25mm ² 3 phase Busbar

Assembly Instructions

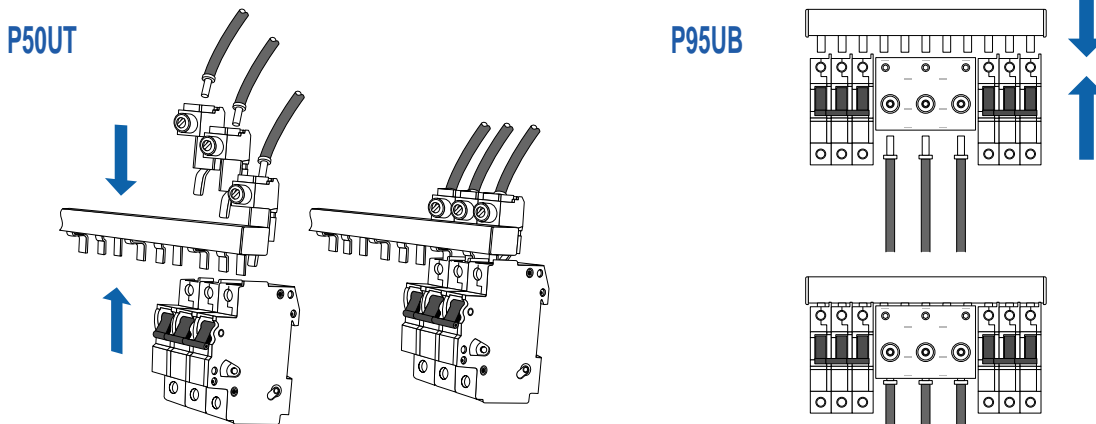

The power feed lugs (Cat. # P50UT) fit together with the lugs of the busbar in the terminals of the MCB/MA.

Miscellaneous Accessories

End Caps



18/25CAP3P

18/25mm² 2&3 phase Busbar

Insulation Caps



BRS5

18/25mm² 1-3 phase Busbar

Type/Cat. No:

For use with:

BUSBAR ORDERING INFORMATION

1 PHASE



For choosing the proper busbar, please consider the following specifications:

1. Number of phases
2. Number of devices / MMCs
3. Number of poles/number of pins
4. Sum of out going device currents ①

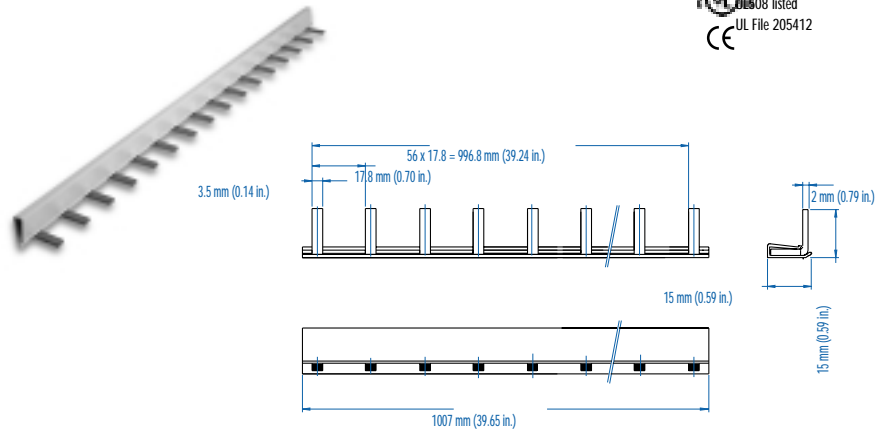

Type/Cat. No. Designation:

$\frac{3}{(a)}$ $\frac{P}{(b)}$ $\frac{25}{(c)}$ $\frac{U}{(d)}$ $\frac{3}{(e)}$ $\frac{H}{(f)}$ / $\frac{\quad}{(g)}$

(a) = Number of transverse copper strips inserted. (Can be 1, 2 or 3 for 1, 2 or 3 phases)

(b) = Pin version

(c) = 18mm² or 25mm² cross-section area

(d) = USA and Canadian design basics

(e) = 1 or 3 track insulation

(f) = Blank - No Spacing
H-Auxiliary Switch (1/2 pole) spacing

(g) = Total number of pins

Technical Specifications:

- Material of Busbar: E-Cu58 F25 Copper
- Insulation Track Material: Bergamid B700 Plastic (130°)
- Electrical Ratings:
 - 18mm²: 80A/480VAC
 - 25mm²: 100A/480VAC
- Manufactured according to VDE 0660 Part 100 and 502, VDE 0606, VDE 0659

18mm ² Type/Cat. No.	No. of Pins ②	No. of MMC to Jumper	Length/ mm
1P18U1/2	2	2x1 pole	32
1P18U1/4	4	4x1 pole	68
1P18U1/8	8	8x1 pole	144
1P18U1/12	12	12x1 pole	208
1P18U1/24	24	24x1 pole	420
1P18U1/36	36	36x1 pole	638
1P18U1/48	48	48x1 pole	852
1P18U1/57	57	57x1 pole	1009

1 PHASE

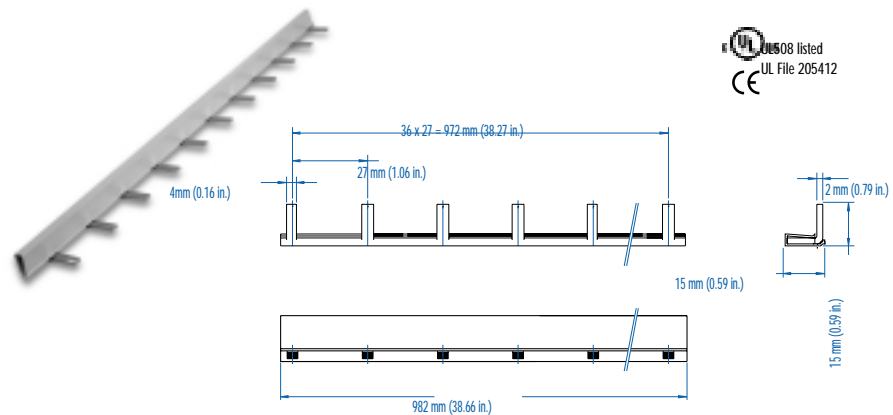

With Auxiliary Switch (1/2 pole) Spacing ③

18mm ² Type/Cat. No.	No. of Pins ②	No. of MMC to Jumper	Length/ mm
1P18U1H/2	2	2x1 pole	48
1P18U1H/4	4	4x1 pole	102
1P18U1H/8	8	8x1 pole	206
1P18U1H/12	12	12x1 pole	314
1P18U1H/18	18	18x1 pole	472
1P18U1H/24	24	24x1 pole	640
1P18U1H/30	30	30x1 pole	804
1P18U1H/37	37	37x1 pole	982

NOTES:

- ① Do not exceed the busbars rated current.
- ② For additional pin configurations, please consult Altech.

③ For one pole spacing busbars, please consult Altech.

2 PHASE

3 PHASE

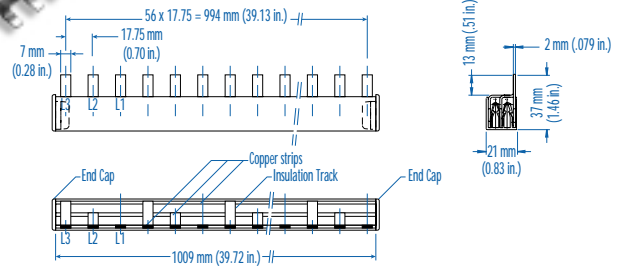
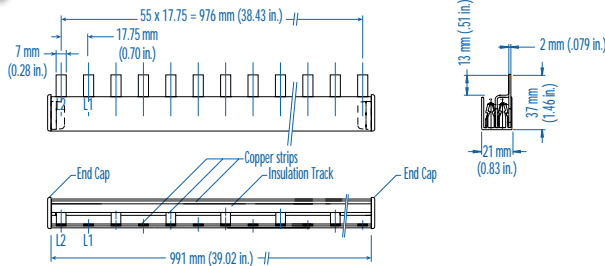
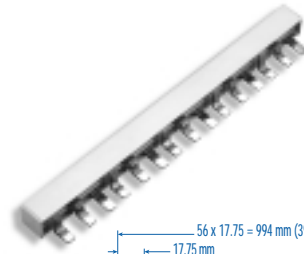
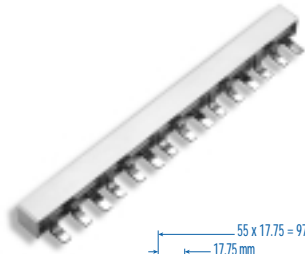

18mm ² Type/Cat. No.	25mm ² Type/Cat. No.	No. of Pins @	No. of MMC to Jumper	Length/ mm
2P18U3/4	2P25U3/4	4	2x2 pole	65
2P18U3/8	2P25U3/8	8	4x2 pole	137
2P18U3/12	2P25U3/12	12	6x2 pole	208
2P18U3/18	2P25U3/18	18	9x2 pole	315
2P18U3/24	2P25U3/24	24	12x2 pole	421
2P18U3/36	2P25U3/36	36	18x2 pole	635
2P18U3/48	2P25U3/48	48	24x2 pole	849
2P18U3/56	2P25U3/56	56	28x2 pole	991

18mm ² Type/Cat. No.	25mm ² Type/Cat. No.	No. of Pins @	No. of MMC to Jumper	Length/ mm
3P18U3/6	3P25U3/6	6	2x3 pole	101
3P18U3/9	3P25U3/9	9	3x3 pole	154
3P18U3/12	3P25U3/12	12	4x3 pole	208
3P18U3/18	3P25U3/18	18	6x3 pole	315
3P18U3/24	3P25U3/24	24	8x3 pole	421
3P18U3/36	3P25U3/36	36	12x3 pole	635
3P18U3/48	3P25U3/48	48	16x3 pole	849
3P18U3/57	3P25U3/57	57	19x3 pole	1009

2 PHASE

3 PHASE

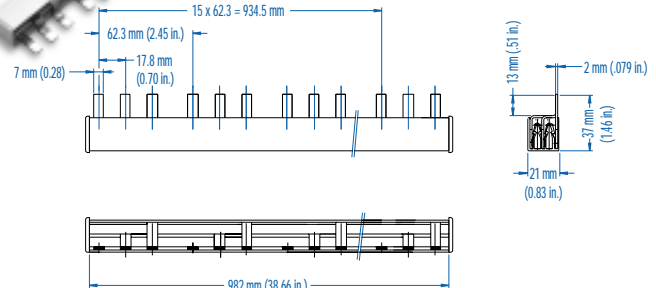
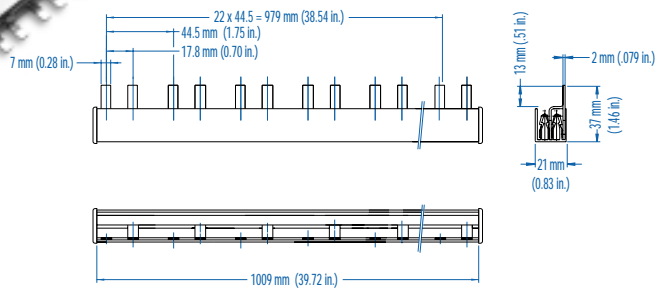
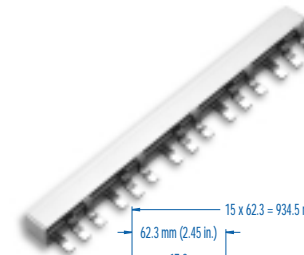
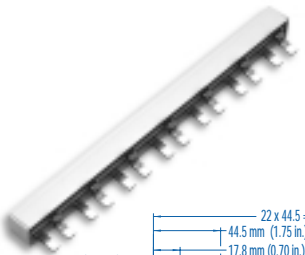

With Auxiliary Switch (1/2 pole) Spacing Ⓢ

With Auxiliary Switch (1/2 pole) Spacing Ⓢ

18mm ² Type/Cat. No.	25mm ² Type/Cat. No.	No. of Pins @	No. of MMC to Jumper	Length/ mm
2P18U3H/4	2P25U3H/4	4	2x2 pole	74
2P18U3H/8	2P25U3H/8	8	4x2 pole	164
2P18U3H/12	2P25U3H/12	12	6x2 pole	253
2P18U3H/18	2P25U3H/18	18	9x2 pole	386
2P18U3H/24	2P25U3H/24	24	12x2 pole	520
2P18U3H/36	2P25U3H/36	36	18x2 pole	787
2P18U3H/46	2P25U3H/46	46	23x2 pole	1009

18mm ² Type/Cat. No.	25mm ² Type/Cat. No.	No. of Pins @	No. of MMC to Jumper	Length/ mm
3P18U3H/6	3P25U3H/6	6	2x3 pole	110
3P18U3H/9	3P25U3H/9	9	3x3 pole	172
3P18U3H/12	3P25U3H/12	12	4x3 pole	235
3P18U3H/18	3P25U3H/18	18	6x3 pole	359
3P18U3H/24	3P25U3H/24	24	8x3 pole	484
3P18U3H/36	3P25U3H/36	36	12x3 pole	733
3P18U3H/48	3P25U3H/48	48	16x3 pole	982

Ⓢ For one pole spacing busbars, please consult Altech.

Ⓢ For one pole spacing busbars, please consult Altech.

Компания «Океан Электроники» предлагает заключение долгосрочных отношений при поставках импортных электронных компонентов на взаимовыгодных условиях!

Наши преимущества:

- Поставка оригинальных импортных электронных компонентов напрямую с производств Америки, Европы и Азии, а так же с крупнейших складов мира;
- Широкая линейка поставок активных и пассивных импортных электронных компонентов (более 30 млн. наименований);
- Поставка сложных, дефицитных, либо снятых с производства позиций;
- Оперативные сроки поставки под заказ (от 5 рабочих дней);
- Экспресс доставка в любую точку России;
- Помощь Конструкторского Отдела и консультации квалифицированных инженеров;
- Техническая поддержка проекта, помощь в подборе аналогов, поставка прототипов;
- Поставка электронных компонентов под контролем ВП;
- Система менеджмента качества сертифицирована по Международному стандарту ISO 9001;
- При необходимости вся продукция военного и аэрокосмического назначения проходит испытания и сертификацию в лаборатории (по согласованию с заказчиком);
- Поставка специализированных компонентов военного и аэрокосмического уровня качества (Xilinx, Altera, Analog Devices, Intersil, Interpoint, Microsemi, Actel, Aeroflex, Peregrine, VPT, Syfer, Eurofarad, Texas Instruments, MS Kennedy, Miteq, Cobham, E2V, MA-COM, Hittite, Mini-Circuits, General Dynamics и др.);

Компания «Океан Электроники» является официальным дистрибьютором и эксклюзивным представителем в России одного из крупнейших производителей разъемов военного и аэрокосмического назначения «JONHON», а так же официальным дистрибьютором и эксклюзивным представителем в России производителя высокотехнологичных и надежных решений для передачи СВЧ сигналов «FORSTAR».



JONHON

«JONHON» (основан в 1970 г.)

Разъемы специального, военного и аэрокосмического назначения:

(Применяются в военной, авиационной, аэрокосмической, морской, железнодорожной, горно- и нефтедобывающей отраслях промышленности)

«FORSTAR» (основан в 1998 г.)

ВЧ соединители, коаксиальные кабели, кабельные сборки и микроволновые компоненты:

(Применяются в телекоммуникациях гражданского и специального назначения, в средствах связи, РЛС, а так же военной, авиационной и аэрокосмической отраслях промышленности).



Телефон: 8 (812) 309-75-97 (многоканальный)

Факс: 8 (812) 320-03-32

Электронная почта: ocean@oceanchips.ru

Web: <http://oceanchips.ru/>

Адрес: 198099, г. Санкт-Петербург, ул. Калинина, д. 2, корп. 4, лит. А