

MAX34565

12V Hot-Plug Switch in TDFN Package

General Description

The MAX34565 is a hot-plug controller for 12V power rails. It is a completely integrated solution including the required power-pass MOSFET device for 12V supplies. During hot-plug, the device controls the supply output voltage ramp (dV/dt) and limits the current at a user-controlled level. The device also limits the output voltage to protect downstream devices from overvoltage events. The MAX34565 is offered in a latching version.

Applications

RAID/Hard Drives	PCI/PCI Express®
Servers	InfiniBand™/SM
Switches/Routers	Base Stations

Features

- ◆ Completely Integrated Hot-Plug Functionality for 12V Power Rails
- ◆ On-Board Power MOSFET
- ◆ No High Power R_{SENSE} Resistor Needed
- ◆ Adjustable Current Limit
- ◆ Adjustable Output Voltage Slew Rate
- ◆ Thermal Fault Indication
- ◆ Output Overvoltage Limiting
- ◆ On-Board Thermal Protection
- ◆ On-Board Charge Pump
- ◆ Latching Version

Ordering Information appears at end of data sheet.

Functional Diagram

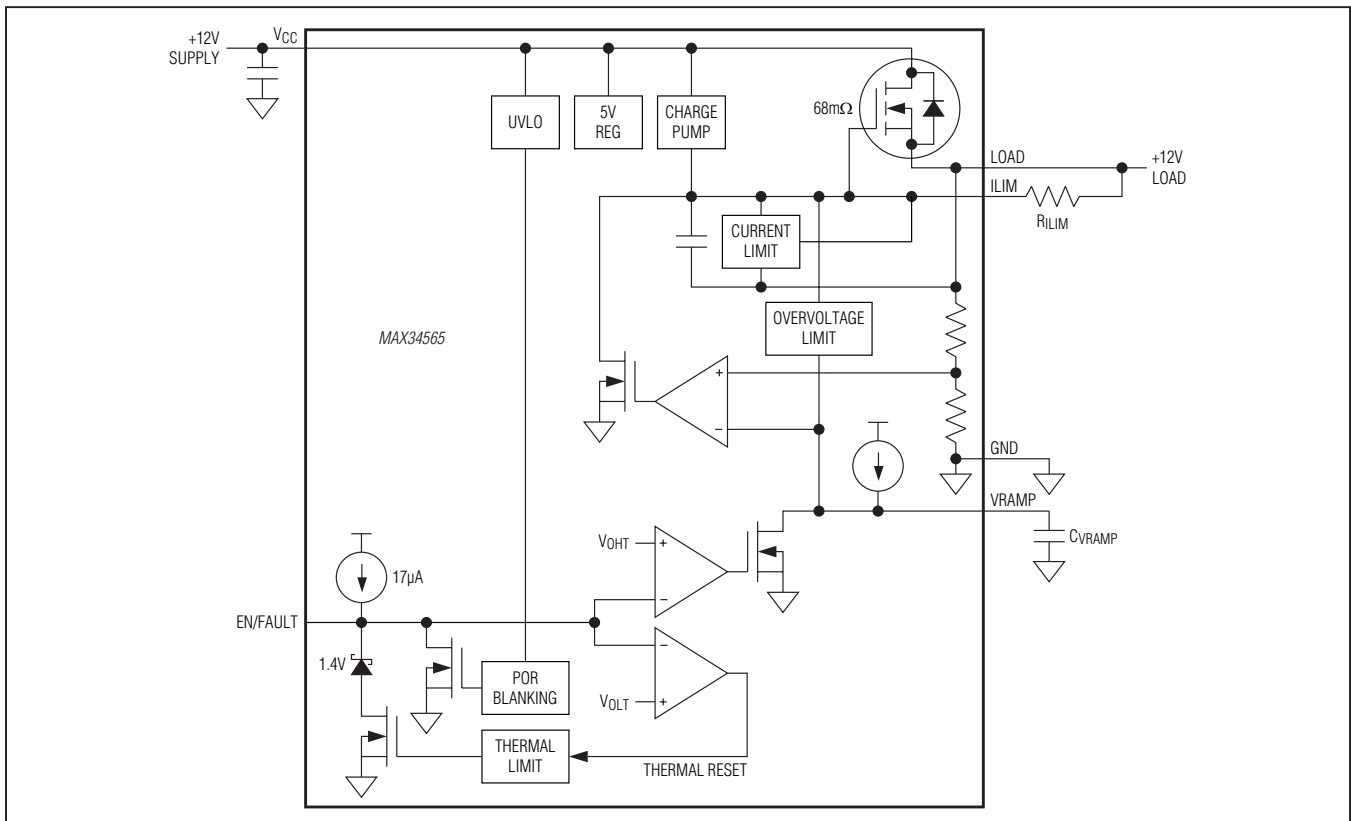

PCI Express is a registered service mark of PCI-SIG Corp.

InfiniBand is a trademark and service mark of InfiniBand Trade Association.

For related parts and recommended products to use with this part, refer to: www.maxim-ic.com/MAX34565.related

For pricing, delivery, and ordering information, please contact Maxim Direct at 1-888-629-4642, or visit Maxim's website at www.maxim-ic.com.

12V Hot-Plug Switch in TDFN Package

ABSOLUTE MAXIMUM RATINGS

(All voltages relative to GND.)

Voltage Range on V_{CC}

Continuous -0.3V to +18V

1ms -0.3V to +22V

Voltage Range on I_{LIM}, VRAMP -0.3V to (V_{CC} + 0.3V),
not to exceed +18V

Voltage on EN/FAULT -0.3V to +6V

12V Drain Current (T_A = +25°C, 0.5sq in. pad) .. 3.6A (continuous)

Continuous Power Dissipation (T_A = +70°C)

TDFN (derate at 24.4mW/°C above +70°C)..... 1951.2mW

Operating Junction Temperature -40°C to +150°C

Storage Temperature Range -55°C to +150°C

Lead Temperature (soldering, 10s) +300°C

Soldering Temperature (reflow) +260°C

Stresses beyond those listed under "Absolute Maximum Ratings" may cause permanent damage to the device. These are stress ratings only, and functional operation of the device at these or any other conditions beyond those indicated in the operational sections of the specifications is not implied. Exposure to absolute maximum rating conditions for extended periods may affect device reliability.

RECOMMENDED OPERATING CONDITIONS

(T_J = -40°C to +150°C, unless otherwise noted.)

PARAMETER	SYMBOL	CONDITIONS	MIN	TYP	MAX	UNITS
V _{CC} Voltage	V _{CC}	(Notes 1, 2)	9	12	13.2	V
R _{ILIM} Value	R _{ILIM}		12		30	Ω
EN/FAULT Low Level (LOAD Disabled)	V _{OLT}				0.80	V
EN/FAULT High Level (LOAD Enabled)	V _{OHT}		3.3			V

ELECTRICAL CHARACTERISTICS

(V_{CC} = 12V, T_J = +25°C, unless otherwise noted.)

PARAMETER	SYMBOL	CONDITIONS	MIN	TYP	MAX	UNITS
Supply Current	I _{CC}	(Note 3)		1.6	2.25	mA
UVLO Rising	V _{UR}		7.5	8.0	8.5	V
UVLO Falling	V _{UF}		6.5	7.0	7.5	V
UVLO Hysteresis	V _{UH}			1		V
On-Resistance	R _{ON}			68	88	mΩ
MOSFET Output Capacitance	C _{OUT}			400		pF
Shutdown Junction Temperature	T _{SHDN}	(Note 4)	+140	+155	+175	°C
Thermal Hysteresis	T _{HYS}			40		°C
Overvoltage Clamp	V _{OVC}		13.5	15	16.5	V
Power-On Short-Circuit Current Limit (Kelvin Sense)	I _{SCL}	R _{ILIM} = 15.4Ω (Note 4)	2.75	3.44	4.25	A
		R _{ILIM} = 24.9Ω		2.1		A
Operating Overload Current Limit (Kelvin Sense)	I _{OVL}	R _{ILIM} = 15.4Ω		4.6		A
		R _{ILIM} = 24.9Ω		3.5		A
VRAMP Time (0V to 12V)	t _{VRAMP}	C _{VRAMP} = 270pF		7		ms
		C _{VRAMP} = 470pF		12		ms
		C _{VRAMP} = 1000pF		25		ms

12V Hot-Plug Switch in TDFN Package

ELECTRICAL CHARACTERISTICS (continued)

($V_{CC} = 12V$, $T_J = +25^\circ C$, unless otherwise noted.)

PARAMETER	SYMBOL	CONDITIONS	MIN	TYP	MAX	UNITS
EN/FAULT Fault Output Voltage	V_{FAULT}		0.82		1.95	V

Note 1: All voltages are referenced to ground. Currents entering the device are specified positive, and currents exiting the device are negative.

Note 2: This supply range guarantees that the LOAD voltage is not clamped by the overvoltage limit.

Note 3: Supply current specified with no load on the LOAD pin.

Note 4: Guaranteed by design; not production tested.

Typical Operating Characteristics

($V_{CC} = 12V$, $T_J = +25^\circ C$, unless otherwise noted.)

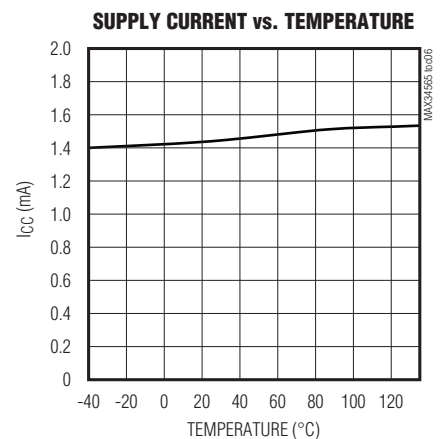
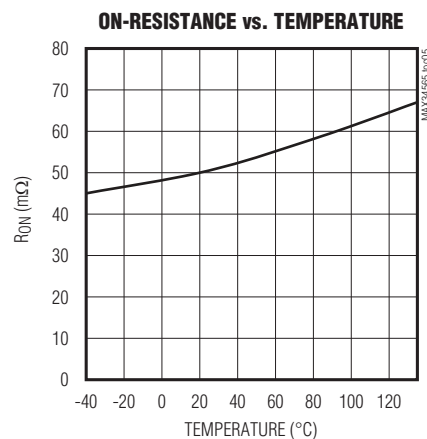
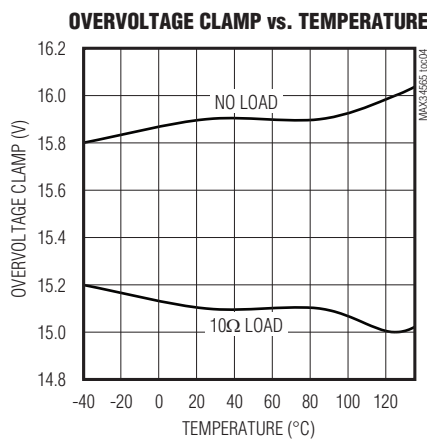
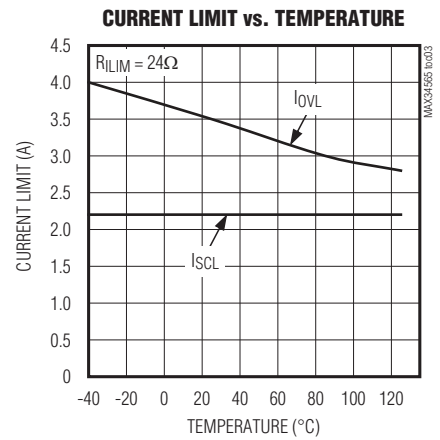
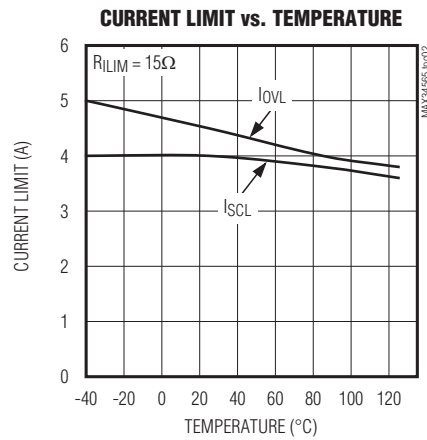
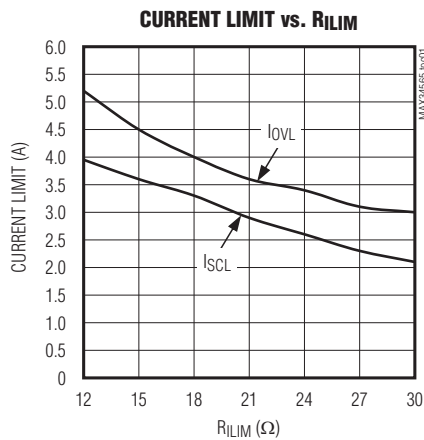

12V Hot-Plug Switch in TDFN Package

Typical Operating Characteristics (continued)

($V_{CC} = 12V$, $T_J = +25^\circ C$, unless otherwise noted.)

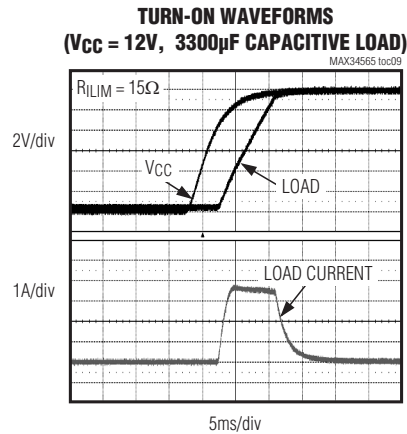
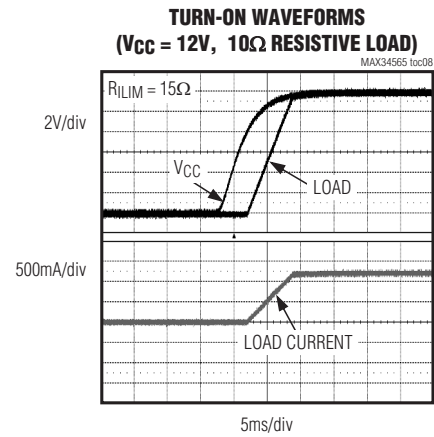
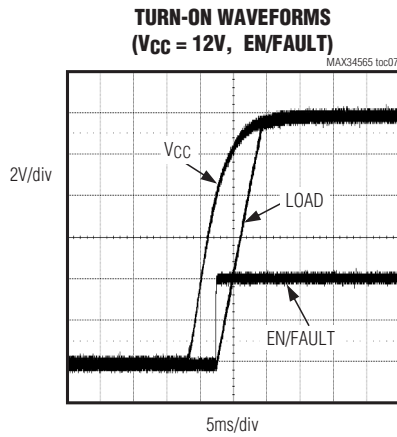

12V Hot-Plug Switch in TDFN Package

Pin Configuration

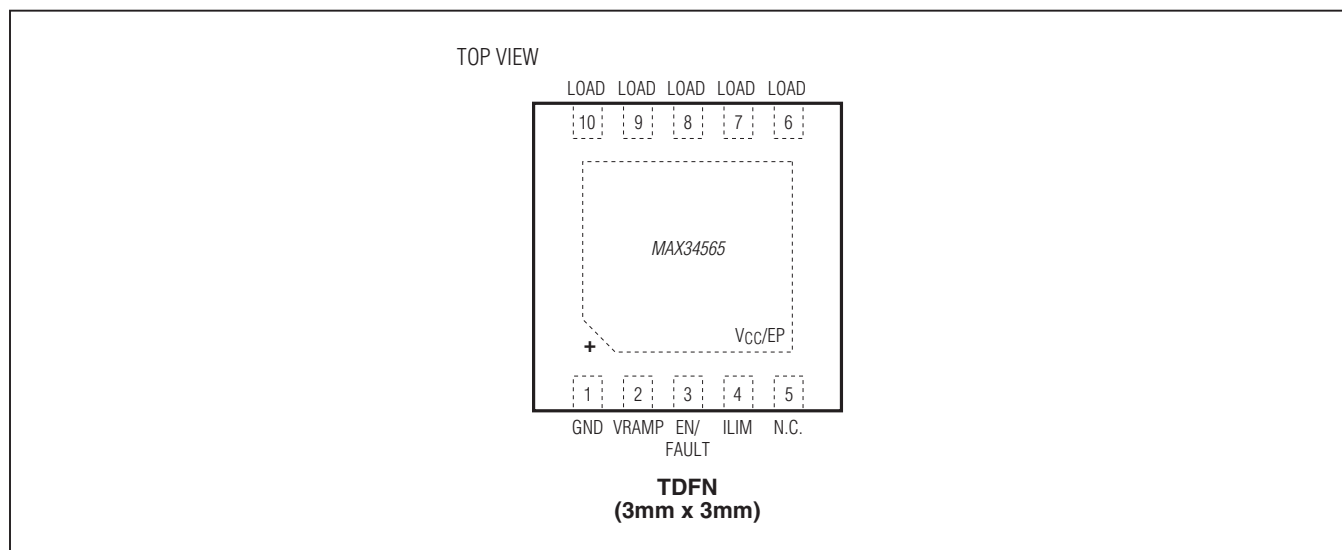

Pin Description

PIN	NAME	FUNCTION
1	GND	Ground Connection
2	VRAMP	Voltage Ramp Control. A capacitor connected to this pin determines the voltage ramp of the LOAD output during turn-on according to the equation $t_{VRAMP} = 25E6 \times C_{VRAMP}$ for voltage ramp from 0 to 12V. This pin can be left open circuit for a minimum ramp time.
3	EN/FAULT	Enable/Fault. This pin is a multiple function digital input-output pin. When this pin is externally pulled low, the MOSFET is turned off. When this pin is left open or not externally driven, the internal pullup reference pulls the input high, and the MOSFET is allowed to turn on. Note: Do not use an external pullup on this pin. If the device experiences a thermal fault, this pin becomes an output that is pulled internally to a mid-level voltage, V_{FAULT} .
4	ILIM	Supply Current Limit Adjust. A resistor from this pin to LOAD determines the current limit for the pass connection.
5	N.C.	No Connection. Do not connect any signal to this pin.
6	LOAD	Load Output. N-channel power MOSFET source connection.
7		
8		
9		
10		
—	V_{CC}/EP	12V Supply Input/Exposed Pad. Power-supply input and n-channel power MOSFET drain connection. Should be connected to a large trace or plane. The EP also acts as a heatsink, and can dissipate heat from the device.

12V Hot-Plug Switch in TDFN Package

Detailed Description

The MAX34565 is a self-contained hot-plug switch intended to be used on +12V power buses to limit through current and to control the power-up output-voltage ramp. The device begins to operate when V_{CC} exceeds the undervoltage lockout level, V_{UR} . At this level, the enable circuit and EN/FAULT pin become active. Once the device has been enabled by exceeding V_{OLT} on the EN/FAULT pin, a gate voltage is applied to the power MOSFET, allowing current to begin flowing from the V_{CC} pad to LOAD.

The device contains an on-board $68m\Omega$ n-channel power MOSFET that is actively closed-loop controlled to ensure that an adjustable current limit is not exceeded. The maximum allowable current through the device is determined by an external resistor connected to the ILIM pin.

The device also contains the ability to control the power-up output-voltage ramp. A capacitor connected to the VRAMP pin sets the desired voltage ramp rate. The output voltage is unconditionally clamped to keep input overvoltage stresses from harming the load. The device has an on-board temperature sensor with hysteresis. If operating conditions cause the device to exceed an internal thermal limit, the device unconditionally shuts down and latches off while waiting for a power-on reset. In the event of thermal shutdown, the device drives the EN/FAULT pin to an intermediate voltage, V_{FAULT} .

Undervoltage Lockout

When voltage is applied to V_{CC} , the undervoltage lockout rising limit, V_{UR} , must be exceeded before the MOSFET circuit is enabled. When the voltage on V_{CC} drops below V_{UF} , the current through the MOSFET is blocked. Note that to allow current to pass through to the LOAD pins, V_{CC} must exceed V_{UR} and the voltage on EN/FAULT must exceed V_{OHT} .

Enable/Fault Function (EN/FAULT)

The EN/FAULT pin can be used to control the output of the device and to indicate that a thermal fault has occurred. The voltage level of the EN/FAULT pin is compared to two internal sources: voltage on limit (V_{OHT}) and voltage off limit (V_{OLT}). When V_{CC} is above V_{UR} and the voltage level on EN/FAULT exceeds V_{OHT} , the voltage ramp circuit turns on, enabling the device's output. When the voltage on EN/FAULT is below V_{OLT} ,

the device's output is disabled. If the internal temperature of the device exceeds T_{SHDN} , a thermal fault occurs and the device drives EN/FAULT to V_{FAULT} . See [Figure 1](#) for the EN/FAULT signal levels.

An open-drain device should be connected to the EN/FAULT pin for proper operation. Because the device pulls EN/FAULT to V_{FAULT} (a three-state condition) in the event of thermal shutdown, this pin should not be connected to an external pullup device. See [Figure 2](#) for a typical application circuit.

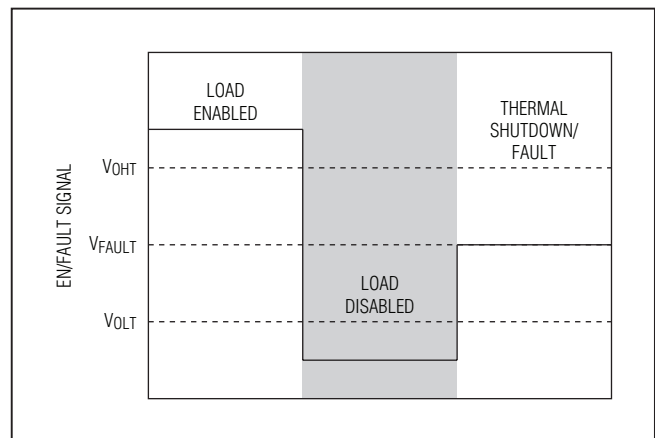

Figure 1. EN/FAULT Signal Levels

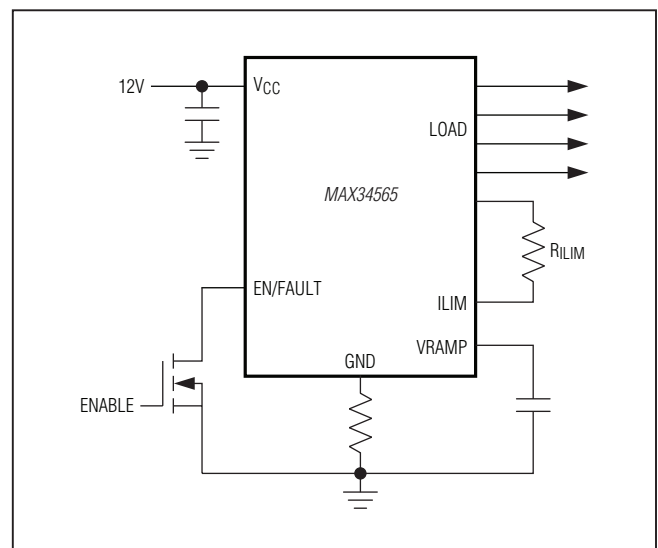

Figure 2. Typical Application Circuit

12V Hot-Plug Switch in TDFN Package

Output-Voltage Ramp (VRAMP)

The voltage ramp circuit uses an operational amplifier to control the gate bias of the n-channel power MOSFET. When the voltage on EN/FAULT is below V_{OLT} , a FET is used to keep C_{VRAMP} discharged, which forces the output voltage to GND. Once the voltage on EN/FAULT is above V_{OHT} , an internal current source begins to charge the external capacitor, C_{VRAMP} , connected to the VRAMP pin. The amplifier controls the gate of the power MOSFET so that the LOAD output voltage divided by two tracks the rising voltage level of C_{VRAMP} . The output voltage continues to ramp until it reaches either the input V_{CC} level or the overvoltage clamp limits.

Overvoltage Limit

The overvoltage-limiting clamp monitors the VRAMP voltage level compared to an internal voltage reference. When the voltage on VRAMP exceeds $V_{OVC}/2$, the gate voltage of the n-channel power MOSFET is reduced, limiting the voltage on LOAD to V_{OVC} even as V_{CC} increases. If the device is in overvoltage for an extended period of time, the device may overheat and enter thermal shutdown. This is caused by the power created by the voltage drop across the power MOSFET and the load current.

Current Limit

The load current is continuously monitored during the initial voltage ramping (I_{SCL}) and during normal operation (I_{OVL}). If the current exceeds the current limit that is set by the external resistance at ILIM, the gate voltage of the power MOSFET is decreased, reducing the output current to the set current limit. Current is limited by the device comparing the voltage difference between the LOAD and ILIM pins to an internal reference voltage. When the output power is initially ramping up, the current limit is I_{SCL} . Once the voltage ramping is complete, the current limit is I_{OVL} . The lower I_{SCL} current limit protects the source if there is a dead short on initial power-up. If the high current is maintained, the device will heat up and the internal temperature will eventually reach T_{SHDN} . The device act as a fuse and automatically disable the current flowing to the load when the temperature of the power MOSFET has exceeded the shutdown junction temperature, T_{SHDN} .

Direct and Kelvin Current Sensing

The current limit circuit can be biased in one of two ways: direct sensing or Kelvin sensing. Using direct sensing, the sense resistor is connected between the ILIM pin and the LOAD pins (Figure 3). Because the bond wires of all five LOAD pins are in parallel, the on-resistance is slightly lower. Using Kelvin sensing, only one of the LOAD pins is connected to the ILIM pin through the sense resistor (Figure 4). Using this circuit, the voltage on the die is sensed, negating any impact of the bond wire resistance. Because four LOAD pins are connected in parallel, the on-resistance is slightly higher.

Thermal Shutdown

The device enters a thermal shutdown state when the temperature of the power MOSFET reaches or exceeds T_{SHDN} , approximately $+155^{\circ}\text{C}$. When T_{SHDN} is exceeded, the thermal-limiting circuitry disables the device using the enable circuitry. The EN/FAULT pin is driven to V_{FAULT} . The device is offered in two different versions: an autoretry version and a latching version.

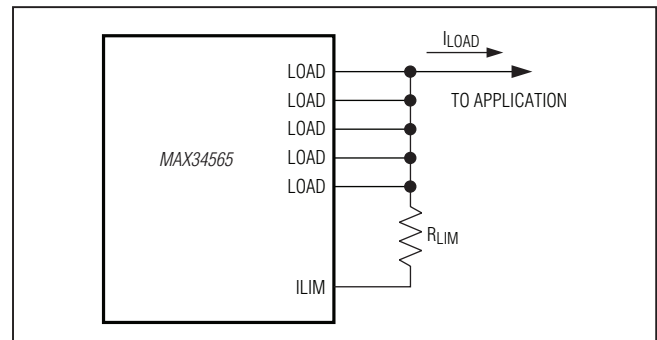

Figure 3. Direct Sensing Circuit

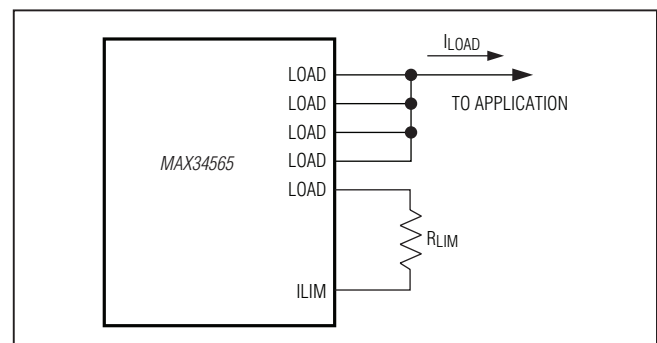

Figure 4. Kelvin Sensing Circuit

12V Hot-Plug Switch in TDFN Package

Latchoff Version

Once the latchoff version has entered thermal shutdown, it does not attempt to turn back on. The only way to turn this device back on is to cycle the power to the device. When power is reapplied to the V_{CC} pad, the junction temperature needs to be less than T_{SHDN} for the device to be enabled.

Applications Information

Exposed Pad (V_{CC})

The exposed pad is the voltage supply pin for the device and should be connected to a large trace or plane. The exposed pad also acts as a heatsink, and can dissipate heat from the device.

Decoupling Capacitors

It is of utmost importance to properly bypass the device's supply pins. A decoupling capacitor absorbs the energy stored in the supply and board parasitic inductance when the FET is turned off, thereby reducing the magnitude of overshoot of V_{CC} . This can be accomplished by using a high-quality (low ESR, low ESL) ceramic capacitor soldered directly between the V_{CC} and GND connections. Any series resistance with this bypass capacitor lowers its effectiveness and is not recommended. A minimum 0.5 μ F ceramic capacitor is required (Figure 5). However, depending on the parasitic inductances present in the end application, a larger capacitor could be necessary.

Current Limiting Resistor

A small resistor (2 Ω to 10 Ω) in series with the GND pin of the device limits current flow during momentary reverse avalanche break down, and consequently limits total parasitic charge injected into the device (Figure 5). If this method is used, it is imperative that the bypass capacitor be directly across chip V_{CC} and ground connections, though not through this resistor.

LOAD and ILIM Connections

Small parasitic resistances in the bond wires of the LOAD pins and in the traces connected to the LOAD pins can result in a voltage offset while current is flowing. Since the voltage drop across R_{ILIM} is used to set the I_{SCL} and I_{OVL} limits, this induced offset can increase the value of I_{SCL} and I_{OVL} from the specified values for any given

R_{ILIM} . To greatly reduce this offset, it is recommended that one of the LOAD pins have a dedicated connection to ILIM through R_{ILIM} , and not be used to pass the LOAD current, I_{LOAD} (Figure 6). This would leave four LOAD pins to pass I_{LOAD} , which should be sufficient. Because there is only a small amount of current passed from this lone LOAD pin to ILIM, there is a negligible voltage offset applied to the internal comparator. This method is the best way to attain an accurate current limit for I_{LOAD} .

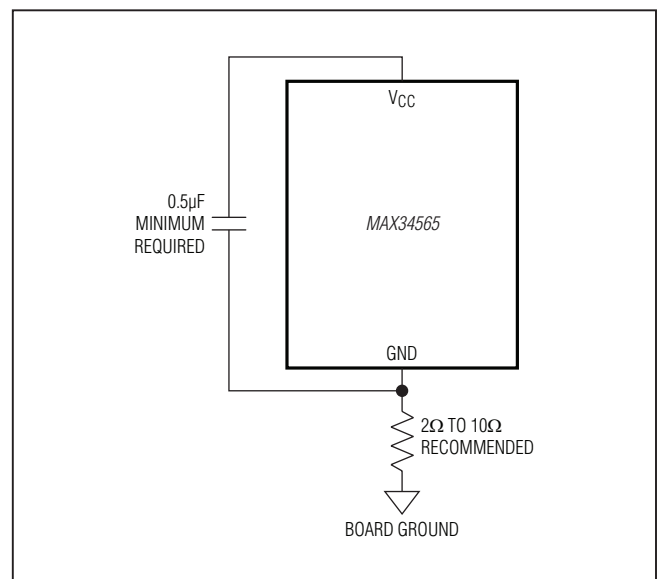

Figure 5. Power Conditioning Circuit

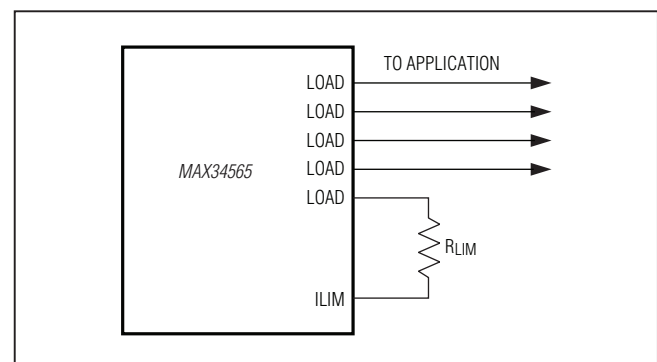

Figure 6. LOAD and ILIM Connections

MAX34565

12V Hot-Plug Switch in TDFN Package

Ordering Information

PART	TEMP RANGE	THERMAL SHUTDOWN	PIN-PACKAGE
MAX34565ETB+	-40°C to +150°C	Latchoff	10 TDFN-EP*
MAX34565ETB+T	-40°C to +150°C	Latchoff	10 TDFN-EP*

+Denotes a lead(Pb)-free/RoHS-compliant package.

T = Tape and reel.

*EP = Exposed pad.

Package Information

For the latest package outline information and land patterns (footprints), go to www.maxim-ic.com/packages. Note that a "+", "#", or "-" in the package code indicates RoHS status only. Package drawings may show a different suffix character, but the drawing pertains to the package regardless of RoHS status.

PACKAGE TYPE	PACKAGE CODE	OUTLINE NO.	LAND PATTERN NO.
10 TDFN-EP	T1033+2	21-0137	90-0061

MAX34565

12V Hot-Plug Switch in TDFN Package

Revision History

REVISION NUMBER	REVISION DATE	DESCRIPTION	PAGES CHANGED
0	12/11	Initial release	—

Maxim cannot assume responsibility for use of any circuitry other than circuitry entirely embodied in a Maxim product. No circuit patent licenses are implied. Maxim reserves the right to change the circuitry and specifications without notice at any time. The parametric values (min and max limits) shown in the Electrical Characteristics table are guaranteed. Other parametric values quoted in this data sheet are provided for guidance.

Maxim Integrated Products, Inc. 160 Rio Robles, San Jose, CA 95134 USA 1-408-601-1000 _____ 10

Компания «Океан Электроники» предлагает заключение долгосрочных отношений при поставках импортных электронных компонентов на взаимовыгодных условиях!

Наши преимущества:

- Поставка оригинальных импортных электронных компонентов напрямую с производств Америки, Европы и Азии, а так же с крупнейших складов мира;
- Широкая линейка поставок активных и пассивных импортных электронных компонентов (более 30 млн. наименований);
- Поставка сложных, дефицитных, либо снятых с производства позиций;
- Оперативные сроки поставки под заказ (от 5 рабочих дней);
- Экспресс доставка в любую точку России;
- Помощь Конструкторского Отдела и консультации квалифицированных инженеров;
- Техническая поддержка проекта, помощь в подборе аналогов, поставка прототипов;
- Поставка электронных компонентов под контролем ВП;
- Система менеджмента качества сертифицирована по Международному стандарту ISO 9001;
- При необходимости вся продукция военного и аэрокосмического назначения проходит испытания и сертификацию в лаборатории (по согласованию с заказчиком);
- Поставка специализированных компонентов военного и аэрокосмического уровня качества (Xilinx, Altera, Analog Devices, Intersil, Interpoint, Microsemi, Actel, Aeroflex, Peregrine, VPT, Syfer, Eurofarad, Texas Instruments, MS Kennedy, Miteq, Cobham, E2V, MA-COM, Hittite, Mini-Circuits, General Dynamics и др.);

Компания «Океан Электроники» является официальным дистрибьютором и эксклюзивным представителем в России одного из крупнейших производителей разъемов военного и аэрокосмического назначения «JONHON», а так же официальным дистрибьютором и эксклюзивным представителем в России производителя высокотехнологичных и надежных решений для передачи СВЧ сигналов «FORSTAR».



JONHON

«JONHON» (основан в 1970 г.)

Разъемы специального, военного и аэрокосмического назначения:

(Применяются в военной, авиационной, аэрокосмической, морской, железнодорожной, горно- и нефтедобывающей отраслях промышленности)

«FORSTAR» (основан в 1998 г.)

ВЧ соединители, коаксиальные кабели, кабельные сборки и микроволновые компоненты:

(Применяются в телекоммуникациях гражданского и специального назначения, в средствах связи, РЛС, а так же военной, авиационной и аэрокосмической отраслях промышленности).



Телефон: 8 (812) 309-75-97 (многоканальный)

Факс: 8 (812) 320-03-32

Электронная почта: ocean@oceanchips.ru

Web: <http://oceanchips.ru/>

Адрес: 198099, г. Санкт-Петербург, ул. Калинина, д. 2, корп. 4, лит. А