

EVALUATION KIT  
AVAILABLE

# MAXIM

## Low-Cost Automotive Sensor Signal Conditioner

MAX1455

### General Description

The MAX1455 is a highly integrated automotive analog-sensor signal processor for resistive element sensors. The MAX1455 provides amplification, calibration, and temperature compensation that enable an overall performance approaching the inherent repeatability of the sensor. The fully analog signal path introduces no quantization noise in the output signal while enabling digitally controlled trimming with integrated 16-bit digital-to-analog converters (DACs). Offset and span are also calibrated using 16-bit DACs, allowing sensor products to be truly interchangeable.

The MAX1455 architecture includes a programmable sensor excitation, a 16-step programmable-gain amplifier (PGA), a 768-byte (6144 bits) internal EEPROM, four 16-bit DACs, an uncommitted op amp, and an on-chip temperature sensor. In addition to offset and span compensation, the MAX1455 provides a unique temperature compensation strategy that was developed to provide a remarkable degree of flexibility while minimizing testing costs.

The MAX1455 is available in die form, 16-pin SSOP and TSSOP packages.

### Customization

Maxim can customize the MAX1455 for high-volume dedicated applications. Using our dedicated cell library of more than 2000 sensor-specific function blocks, Maxim can quickly provide a modified MAX1455 solution. Contact Maxim for further information.

### Applications

Pressure Sensors and Transducers  
Piezoresistive Silicon Sensors  
Strain Gauges  
Resistive Element Sensors  
Accelerometers  
Humidity Sensors  
MR and GMR Sensors

### Outputs

Ratiometric Voltage Output  
Programmable Output Clip Limits

**A detailed Functional Diagram appears at end of data sheet.**

*Secure-Lock is a trademark of Maxim Integrated Products, Inc.*

### Features

- ◆ Provides Amplification, Calibration, and Temperature Compensation
- ◆ Selectable Output Clipping Limits
- ◆ Accommodates Sensor Output Sensitivities from 5mV/V to 40mV/V
- ◆ Single-Pin Digital Programming
- ◆ No External Trim Components Required
- ◆ 16-Bit Offset and Span Calibration Resolution
- ◆ Fully Analog Signal Path
- ◆ PRT Bridge Can Be Used for Temperature-Correction Input
- ◆ On-Chip Lookup Table Supports Multipoint Calibration Temperature Correction
- ◆ Fast 3.2kHz Frequency Response
- ◆ On-Chip Uncommitted Op Amp
- ◆ Secure-Lock™ Prevents Data Corruption

### Ordering Information

PART	TEMP. RANGE	PIN-PACKAGE
MAX1455EUE*	-40°C to +85°C	16 TSSOP
MAX1455AUE*	-40°C to +125°C	16 TSSOP
MAX1455EAE	-40°C to +85°C	16 SSOP
MAX1455AAE	-40°C to +125°C	16 SSOP
MAX1455C/D	-40°C to +85°C	Dice**

\*Future product—contact factory for availability.

\*\*Dice are tested at  $T_A = +25^\circ\text{C}$ , DC parameters only.

### Pin Configuration

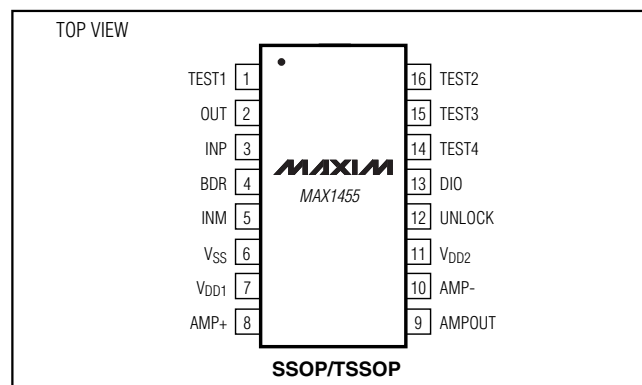

MAXIM

Maxim Integrated Products 1

**For pricing, delivery, and ordering information, please contact Maxim/Dallas Direct! at 1-888-629-4642, or visit Maxim's website at [www.maxim-ic.com](http://www.maxim-ic.com).**

# Low-Cost Automotive Sensor Signal Conditioner

## ABSOLUTE MAXIMUM RATINGS

Supply Voltage,  $V_{DD\_}$  to  $V_{SS}$  ..... -0.3V, +6V  
 $V_{DD1} - V_{DD2}$  ..... -0.3V, +0.6V  
 All Other Pins ..... ( $V_{SS} - 0.3V$ ) to ( $V_{DD\_} + 0.3V$ )  
 Short-Circuit Duration, OUT, BDR, AMPOUT ..... Continuous  
 Continuous Power Dissipation ( $T_A = +70^\circ C$ )  
 16-Pin SSOP (derate 8.00mW/ $^\circ C$  above  $+70^\circ C$ ) ..... 640mW

Operating Temperature Ranges ( $T_{MIN}$  to  $T_{MAX}$ )  
 MAX1455EUE .....  $-40^\circ C$  to  $+85^\circ C$   
 MAX1455AUE .....  $-40^\circ C$  to  $+125^\circ C$   
 MAX1455C/D .....  $-40^\circ C$  to  $+85^\circ C$   
 MAX1455EAE .....  $-40^\circ C$  to  $+85^\circ C$   
 MAX1455AAE .....  $-40^\circ C$  to  $+125^\circ C$   
 Storage Temperature Range .....  $-65^\circ C$  to  $+150^\circ C$   
 Lead Temperature (soldering, 10s) .....  $+300^\circ C$

Stresses beyond those listed under "Absolute Maximum Ratings" may cause permanent damage to the device. These are stress ratings only, and functional operation of the device at these or any other conditions beyond those indicated in the operational sections of the specifications is not implied. Exposure to absolute maximum rating conditions for extended periods may affect device reliability.

## ELECTRICAL CHARACTERISTICS

( $V_{DD} = +5V$ ,  $V_{SS} = 0$ ,  $T_A = +25^\circ C$ , unless otherwise noted.)

PARAMETER	SYMBOL	CONDITIONS	MIN	TYP	MAX	UNITS
<b>GENERAL CHARACTERISTICS</b>						
Supply Voltage	$V_{DD}$		4.5	5.0	5.5	V
Supply Current	$I_{DD}$	$I_{DD1} + I_{DD2}$ (Note 1)		3.0	6.0	mA
Oscillator Frequency	$f_{OSC}$		0.85	1	1.15	MHz
<b>ANALOG INPUT</b>						
Input Impedance	$R_{IN}$			1		$M\Omega$
Input-Referred Adjustable Offset Range		Offset TC = 0 (Note 2), minimum gain		$\pm 150$		mV
Input-Referred Offset Tempco		$T_A = T_{MIN}$ to $T_{MAX}$		$\pm 1$		$\mu V/^\circ C$
Amplifier Gain Nonlinearity				0.025		%
Common-Mode Rejection Ratio	CMRR	Specified for common-mode voltages between $V_{SS}$ and $V_{DD}$		90		dB
Minimum Input-Referred FSO Range		(Note 3)		7		mV/V
Maximum Input-Referred FSO Range		(Note 3)		40		mV/V
<b>ANALOG OUTPUT</b>						
Minimum Differential Signal-Gain Range		PGA [3:0] = 0000		39		V/V
Maximum Differential Signal-Gain Range		PGA [3:0] = 1111		234		V/V
Output Clip Voltage Settings	$V_{OUT}$	No load, $T_A = T_{MIN}$ to $T_{MAX}$	Clip[1:0] = 00	Low	0.10	V
				High	4.90	
			Clip[1:0] = 01	Low	0.15	
				High	4.85	
			Clip[1:0] = 10	Low	0.20	
				High	4.80	
			Clip[1:0] = 11	Low	0.25	
				High	4.75	
Load Current Source		$V_{OUT} = +0.5V$ to $+4.5V$ , $T_A = T_{MIN}$ to $T_{MAX}$ , Clip[1:0] = 00			1	mA

# Low-Cost Automotive Sensor Signal Conditioner

MAX1455

## ELECTRICAL CHARACTERISTICS (continued)

( $V_{DD} = +5V$ ,  $V_{SS} = 0$ ,  $T_A = +25^\circ C$ , unless otherwise noted.)

PARAMETER	SYMBOL	CONDITIONS	MIN	TYP	MAX	UNITS
Load Current Sink		$V_{OUT} = +0.5V$ to $+4.5V$ , $T_A = T_{MIN}$ to $T_{MAX}$ , Clip[1:0] = 00			2	mA
DC Output Impedance				1		$\Omega$
Offset DAC Output Ratio		$\Delta V_{OUT}/\Delta ODAC$		1.0		V/V
Offset TC DAC Output Ratio		$\Delta V_{OUT}/\Delta OTCDAC$		1.0		V/V
Step Response		0% to 63% of final value		300		$\mu s$
Output Capacitive Load					1000	nF
Output Noise		DC to 1kHz (gain = minimum, source impedance = $5k\Omega$ )		2.5		mV <sub>RMS</sub>
<b>BRIDGE DRIVE</b>						
Bridge Current	I <sub>BDR</sub>	$V_{BDR} \leq 3.75V$	0.1	0.5	2	mA
Current Mirror Ratio				12		mA/mA
Minimum FSODAC Code		Recommended minimum value		4000		Hex
<b>DIGITAL-TO-ANALOG CONVERTERS</b>						
DAC Resolution				16		Bits
ODAC Bit Weight		$\Delta V_{OUT}/\Delta CODE$ , DAC reference = $V_{DD} = +5.0V$ (Note 4)		153		$\mu V/Bit$
OTCDAC Bit Weight		$\Delta V_{OUT}/\Delta CODE$ , DAC reference = $V_{BDR} = 2.5V$ (Note 4)		76		$\mu V/Bit$
FSODAC Bit Weight		$\Delta V_{OUT}/\Delta CODE$ , DAC reference = $V_{DD} = +5.0V$ (Note 4)		153		$\mu V/Bit$
FSOTCDAC Bit Weight		$\Delta V_{OUT}/\Delta CODE$ , DAC reference = $V_{BDR} = 2.5V$ (Note 4)		76		$\mu V/Bit$
<b>COARSE-OFFSET DAC</b>						
IRODAC Resolution		Excluding sign bit		3		Bits
IRODAC Bit Weight		$\Delta V_{OUT}/\Delta CODE$ , input referred, DAC reference = $V_{DD} = +5.0V$ (Note 4)		9		mV/Bit
<b>INTERNAL RESISTORS</b>						
Current-Source Reference	R <sub>ISRC</sub>			75		$k\Omega$
Full-Span Output (FSO) Trim Resistor	$\Delta R_{STC}$			75		$k\Omega$
Resistor Temperature Coefficient		Applies to R <sub>ISRC</sub> and $\Delta R_{STC}$		1333		ppm/ $^\circ C$
Minimum Resistance Value		Applies to R <sub>ISRC</sub> and $\Delta R_{STC}$		60		$k\Omega$
Maximum Resistance Value		Applies to R <sub>ISRC</sub> and $\Delta R_{STC}$		90		$k\Omega$
Resistor Matching		R <sub>ISRC</sub> to $\Delta R_{STC}$		1		%
<b>AUXILIARY OP AMP</b>						
Open-Loop Gain				90		dB
Input Common-Mode Range	V <sub>CM</sub>		$V_{SS}$		$V_{DD}$	V
Output Swing		No load, $T_A = T_{MIN}$ to $T_{MAX}$	$V_{SS} + 0.01$		$V_{DD} - 0.01$	V

# Low-Cost Automotive Sensor Signal Conditioner

## ELECTRICAL CHARACTERISTICS (continued)

( $V_{DD} = +5V$ ,  $V_{SS} = 0$ ,  $T_A = +25^\circ C$ , unless otherwise noted.)

PARAMETER	SYMBOL	CONDITIONS	MIN	TYP	MAX	UNITS
Output Current Drive		$V_{OUT} = (V_{SS} + 0.25)$ to $(V_{DD} - 0.25)$	-1		+1	mA
Common-Mode Rejection Ratio	CMRR	$V_{CM} = V_{SS}$ to $V_{DD}$		70		dB
Input Offset Voltage	$V_{OS}$	$V_{IN} = 2.5V$ unity-gain buffer (Note 5)		$\pm 1$	$\pm 20$	mV
					$\pm 25$	
Unity-Gain Bandwidth				2		MHz
<b>TEMPERATURE-TO-DIGITAL CONVERTER</b>						
Temperature ADC Resolution				8		Bits
Offset				$\pm 3$		Bits
Gain				1.45		$^\circ C/Bit$
Nonlinearity				$\pm 1$		LSB
Lowest Digital Output				00		Hex
Highest Digital Output				AF		Hex
<b>EEPROM</b>						
Maximum Erase/Write Cycles		(Notes 6, 7)		10k		Cycles
Erase Time		(Note 8)	7.1			ms

**Note 1:** Excludes sensor or load current.

**Note 2:** This is the maximum allowable sensor offset.

**Note 3:** This is the sensor's sensitivity normalized to its drive voltage, assuming a desired full-span output of 4V and a bridge voltage of 2.5V.

**Note 4:** Bit weight is ratiometric to  $V_{DD}$ .

**Note 5:** All units production tested at  $T_A = +25^\circ C$ . Limits over temperature are guaranteed by design.

**Note 6:** Programming of the EEPROM at temperatures below  $+70^\circ C$  is recommended.

**Note 7:** For operation above  $+70^\circ C$ , limit erase/write cycle to 100.

**Note 8:** All erase commands require 7.1ms minimum time.

## Typical Operating Characteristics

( $V_{DD} = +5V$ ,  $V_{SS} = 0$ ,  $T_A = +25^\circ C$ , unless otherwise noted.)

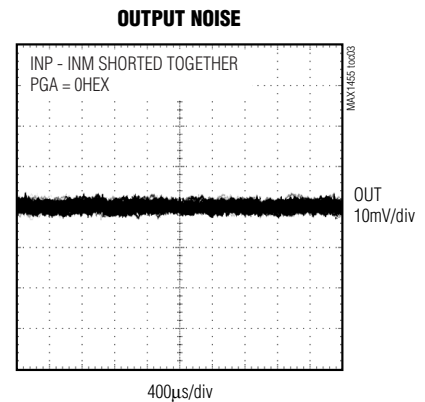
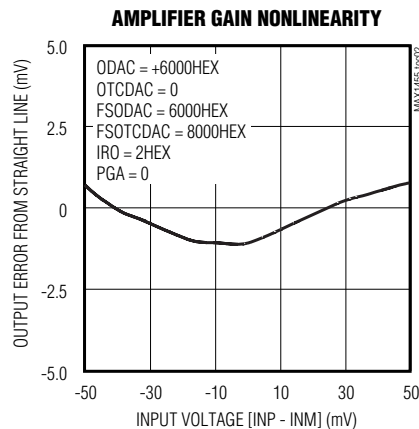
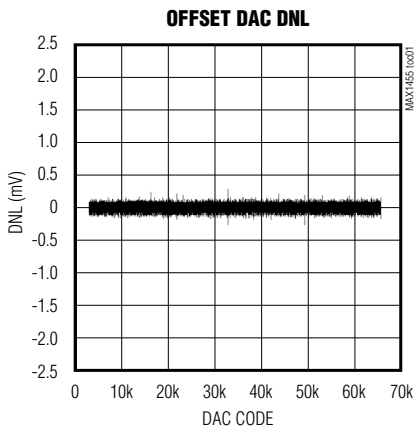

# Low-Cost Automotive Sensor Signal Conditioner

## Pin Description

**MAX1455**

PIN	NAME	FUNCTION
1, 15, 16	TEST1, TEST3, TEST2	Test Pins. Connect to V <sub>SS</sub> or leave unconnected.
2	OUT	Analog Output. Internal voltage nodes can be accessed in digital mode. OUT can be parallel connected to DIO. Bypass OUT to ground with a 0.1μF capacitor to reduce output noise.
3	INP	Positive Input. Can be swapped to INM by the Configuration register.
4	BDR	Bridge Drive Output
5	INM	Negative Input. Can be swapped to INP by the Configuration register.
6	V <sub>SS</sub>	Negative Supply Voltage
7	V <sub>DD1</sub>	Positive Supply Voltage 1. Connect a 0.1μF capacitor from V <sub>DD</sub> to V <sub>SS</sub> .
8	AMP+	Auxiliary Op Amp Positive Input
9	AMPOUT	Auxiliary Op Amp Output
10	AMP-	Auxiliary Op Amp Negative Input
11	V <sub>DD2</sub>	Positive Supply Voltage 2. Connect a 0.47μF capacitor from V <sub>DD2</sub> to V <sub>SS</sub> . Connect V <sub>DD2</sub> to V <sub>DD1</sub> or for improved noise performance, connect a 1kΩ resistor to V <sub>DD1</sub> .
12	UNLOCK	Secure-Lock Disable. There is a 150μA pulldown to V <sub>SS</sub> . Connect to V <sub>DD</sub> to disable Secure-Lock and enable serial communication.
13	DIO	Digital Input Output. Single-pin serial communication port. There are no internal pullups on DIO. Connect pullup resistor from DIO to V <sub>DD</sub> when in digital mode.
14	TEST4	Test Pin. Do not connect.

## Detailed Description

The MAX1455 provides amplification, calibration, and temperature compensation to enable an overall performance approaching the inherent repeatability of the sensor. The fully analog signal path introduces no quantization noise in the output signal while enabling digitally controlled trimming with the integrated 16-bit DACs. The MAX1455 includes four selectable high/low clipping limits set in discrete 50mV steps from 0.1V/4.9V to 0.25V/4.75V. Offset and span can be calibrated to within ±0.02% of span.

The MAX1455 architecture includes a programmable sensor excitation, a 16-step PGA, a 768-byte (6144 bits) internal EEPROM, four 16-bit DACs, an uncommitted op amp, and an on-chip temperature sensor. The MAX1455 also provides a unique temperature compensation strategy that was developed to provide a remarkable degree of flexibility while minimizing testing costs.

The customer can select from 1 to 114 temperature points to compensate their sensor. This allows the latitude to compensate a sensor with a simple first-order linear correction or match an unusual temperature curve. Programming up to 114 independent 16-bit

EEPROM locations corrects performance in 1.5°C temperature increments over a range of -40°C to +125°C. For sensors that exhibit a characteristic temperature performance, a select number of calibration points can be used with a number of preset values that define the temperature curve. The sensor and the MAX1455 should be at the same temperature during calibration and use. This allows the electronics and sensor errors to be compensated together and optimizes performance. For applications where the sensor and electronics are at different temperatures, the MAX1455 can use the sensor bridge as an input to correct for temperature errors.

The single pin, serial DIO communication architecture and the ability to timeshare its activity with the sensor's output signal enables output sensing and calibration programming on a single line by parallel connecting OUT and DIO. The MAX1455 provides a Secure-Lock feature that allows the customer to prevent modification of sensor coefficients and the 52-byte user-definable EEPROM data after the sensor has been calibrated. The Secure-Lock feature also provides a hardware override to enable factory rework and recalibration by assertion of logic high on the UNLOCK pin.

# Low-Cost Automotive Sensor Signal Conditioner

The MAX1455 allows complete calibration and sensor verification to be performed at a single test station. Once calibration coefficients have been stored in the ASIC, the customer can choose to retest in order to verify performance as part of a regular QA audit or to generate final test data on individual sensors. In addition, Maxim has developed a pilot production test system to reduce time to market. Engineering test evaluation and pilot production of the MAX1455 can be performed without expending the cost and time to develop in-house test capabilities. Contact Maxim for additional information.

Frequency response can be user adjusted to values lower than the 3.2kHz bandwidth by using the uncommitted op amp and simple passive components.

The MAX1455 (Figure 1) provides an analog amplification path for the sensor signal. It uses a digitally controlled analog path for nonlinear temperature correction. For PRT applications, analog architecture is available for first-order temperature correction. Calibration and correction are achieved by varying the offset and gain of a PGA and by varying the sensor bridge excitation current or voltage. The PGA utilizes a switched capacitor CMOS technology, with an input-referred offset trimming range of more than  $\pm 150\text{mV}$  with an approximate  $3\mu\text{V}$  resolution (16 bits). The PGA provides gain values from  $39\text{V/V}$  to  $234\text{V/V}$  in 16 steps.

The MAX1455 uses four 16-bit DACs with calibration coefficients stored by the user in an internal  $768 \times 8$  EEPROM (6144 bits). This memory contains the following information, as 16-bit-wide words:

- Configuration register
- Offset calibration coefficient table
- Offset temperature coefficient register
- FSO calibration coefficient table
- FSO temperature correction register
- 52 bytes (416 bits) uncommitted for customer programming of manufacturing data (e.g., serial number and date)

## Offset Correction

Initial offset correction is accomplished at the input stage of the signal gain amplifiers by a coarse offset setting. Final offset correction occurs through the use of a temperature-indexed lookup table with one hundred seventy-six 16-bit entries. The on-chip temperature sensor provides a unique 16-bit offset trim value from the table with an indexing resolution of approximately  $1.5^\circ\text{C}$  from  $-40^\circ\text{C}$  to  $+125^\circ\text{C}$ . Every millisecond, the on-chip temperature sensor provides indexing into the offset lookup table in EEPROM and the resulting value is

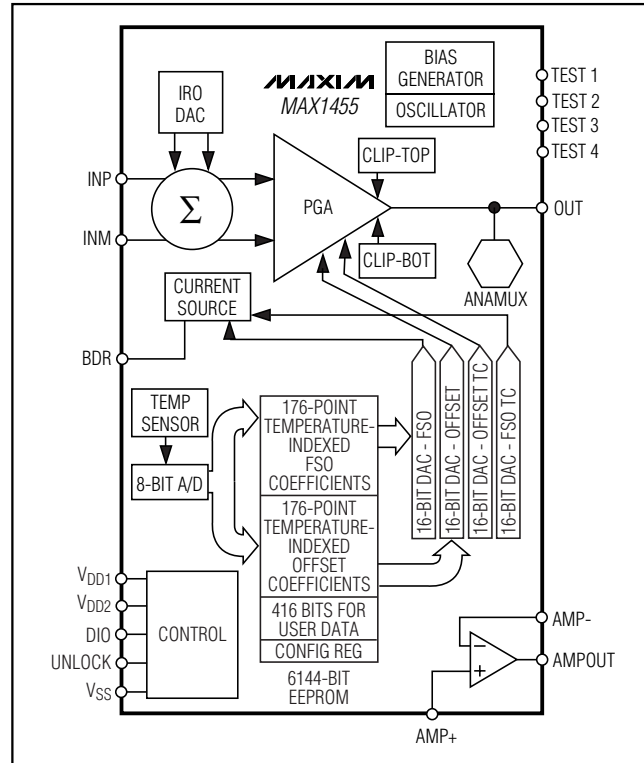

Figure 1. Functional Diagram

transferred to the offset DAC register. The resulting voltage is fed into a summing junction at the PGA output, compensating the sensor offset with a resolution of  $\pm 76\mu\text{V}$  ( $\pm 0.0019\%$  FSO). If the offset TC DAC is set to zero, then the maximum temperature error is equivalent to  $1^\circ\text{C}$  of temperature drift of the sensor, given that the Offset DAC has corrected the sensor every  $1.5^\circ\text{C}$ . The temperature indexing boundaries are outside the specified absolute maximum ratings. The minimum indexing value is 00hex, corresponding to approximately  $-69^\circ\text{C}$ . All temperatures below this value output the coefficient value at index 00hex. The maximum indexing value is AFhex, which is the highest lookup table entry. All temperatures higher than approximately  $+184^\circ\text{C}$  output the highest lookup table index value. No indexing wrap-around errors are produced.

## FSO Correction

Two functional blocks control the FSO gain calibration. First, a coarse gain is set by digitally selecting the gain of the PGA. Second, FSODAC sets the sensor bridge current or voltage with the digital input obtained from a temperature indexed reference to the FSO lookup table in EEPROM. FSO correction occurs through the use of a

# Low-Cost Automotive Sensor Signal Conditioner

temperature indexed lookup table with one hundred seventy-six 16-bit entries. The on-chip temperature sensor provides a unique FSO trim from the table with an indexing resolution approaching one 16-bit value every 1.5°C from -40°C to +125°C. The temperature indexing boundaries are outside the specified absolute maximum ratings. The minimum indexing value is 00hex, corresponding to approximately -69°C. All temperatures below this value output the coefficient value at index 00hex. The maximum indexing value is AFhex, which is the highest lookup table entry. All temperatures higher than approximately +184°C output the highest lookup table index value. No indexing wraparound errors are produced.

## Linear and Nonlinear Temperature Compensation

Writing 16-bit calibration coefficients into the offset TC and FSOTC registers compensates first-order temperature errors. The piezoresistive sensor is powered by a current source resulting in a temperature-dependent bridge voltage due to the sensor's temperature coefficient resistance (TCR). The reference inputs of the offset TC DAC and FSOTC DAC are connected to the bridge voltage. The DAC output voltages track the bridge voltage as it varies with temperature, and by varying the offset TC and FSOTC digital code and a portion of the bridge voltage, which is temperature dependent, is used to compensate the first-order temperature errors.

The internal feedback resistors (R<sub>ISRC</sub> and R<sub>STC</sub>) for FSO temperature compensation are set to 75kΩ.

To calculate the required offset TC and FSOTC compensation coefficients, two test temperatures are needed. After taking at least two measurements at each temperature, calibration software (in a host computer) calculates the correction coefficients and writes them to the internal EEPROM.

With coefficients ranging from 0000hex to FFFFhex and a +5V reference, each DAC has a resolution of 76μV. Two of the DACs (offset TC and FSOTC) utilize the sensor bridge voltage as a reference. Since the sensor bridge voltage is approximately set to +2.5V, the FSOTC and offset TC exhibit a step size of less than 38μV.

For high-accuracy applications (errors less than 0.25%), the first-order offset TC and FSOTC should be compensated with the offset TC and FSOTC DACs, and the residual higher order terms with the lookup table. The offset and FSO compensation DACs provide unique compensation values for approximately 1.5°C of temperature change as the temperature indexes the address pointer through the coefficient lookup table. Changing the offset does not affect the FSO; however,

changing the FSO affects the offset due to the nature of the bridge. The temperature is measured on both the MAX1455 die and at the bridge sensor. It is recommended to compensate the first-order temperature errors using the bridge sensor temperature.

## Typical Ratiometric Operating Circuit

Ratiometric output configuration provides an output that is proportional to the power-supply voltage. This output can then be applied to a ratiometric ADC to produce a digital value independent of supply voltage. Ratiometricity is an important consideration for battery-operated instruments, automotive, and some industrial applications.

The MAX1455 provides a high-performance ratiometric output with a minimum number of external components (Figure 2). These external components include the following:

- One supply bypass capacitor
- One optional output EMI suppression capacitor

## Typical Nonratiometric Operating Circuit (5.5VDC < VPWR < 28VDC)

Nonratiometric output configuration enables the sensor power to vary over a wide range. A low-dropout voltage regulator, such as the MAX1615, is incorporated in the circuit to provide a stable supply and reference for MAX1455 operation. A typical example is shown in Figure 3. Nonratiometric operation is valuable when wide ranges of input voltage are to be expected and the system A/D or readout device does not enable ratiometric operation.

## Internal Calibration Registers

The MAX1455 has five 16-bit internal calibration registers (ICRs) that are loaded from EEPROM, or loaded from the serial digital interface.

Data can be loaded into the ICRs under three different circumstances.

### Normal Operation, Power-On Initialization Sequence:

- The MAX1455 has been calibrated, the Secure-Lock byte is set (CL[7:0] = FFhex), and UNLOCK is low.
- Power is applied to the device.
- The power-on reset (POR) functions have been completed.
- Registers CONFIG, OTCDAC, and FSOTCDAC are refreshed from EEPROM.

# Low-Cost Automotive Sensor Signal Conditioner

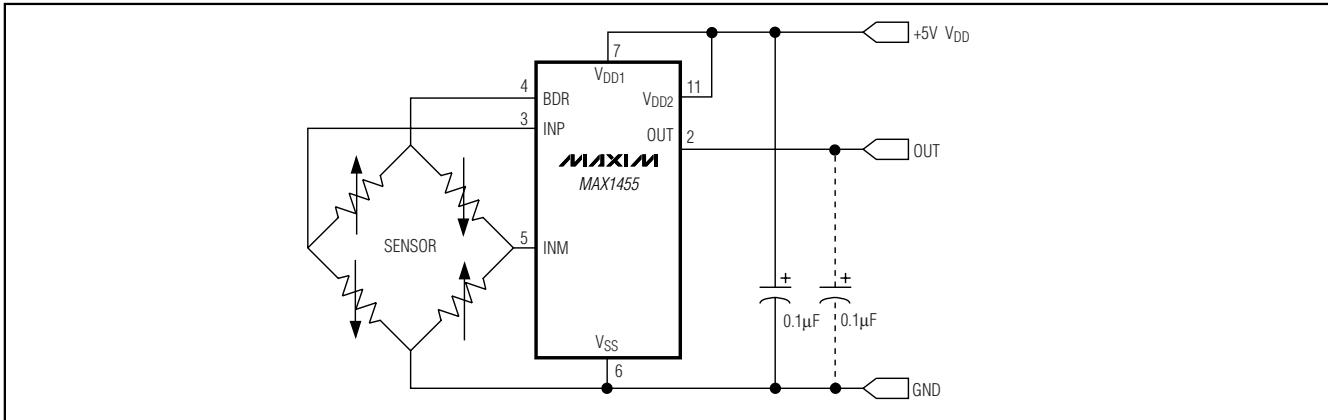

Figure 2. Basic Ratiometric Output Configuration

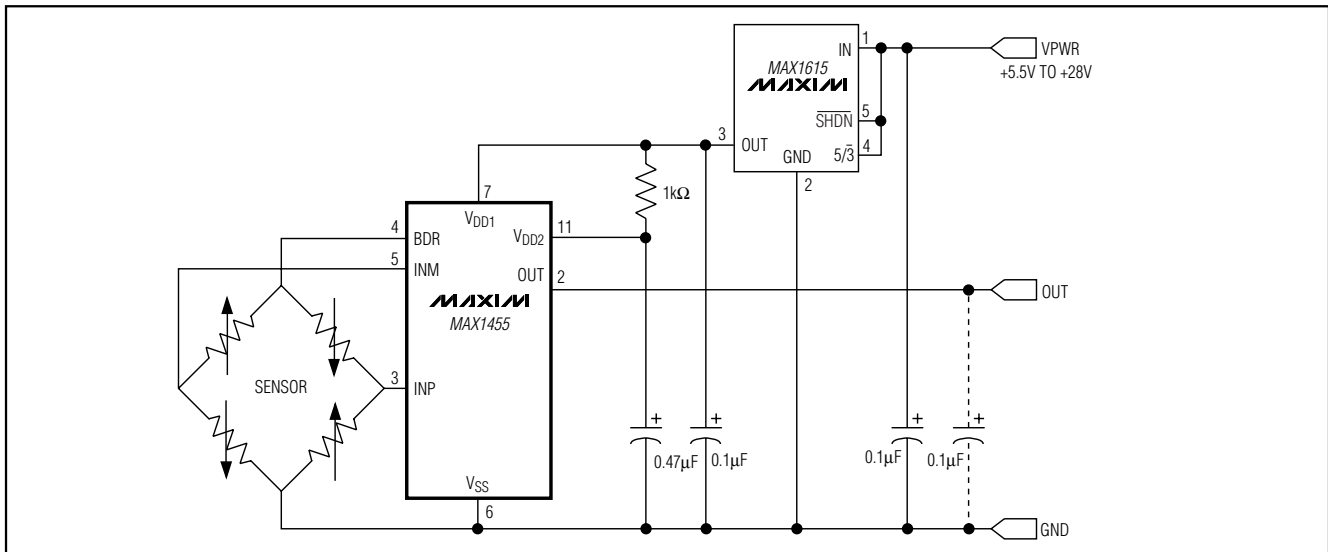

Figure 3. Basic Nonratiometric Output Configuration

- Registers ODAC and FSODAC are refreshed from the temperature indexed EEPROM locations.

### Normal Operation, Continuous Refresh:

- The MAX1455 has been calibrated, the Secure-Lock byte has been set (CL[7:0] = FFhex), and UNLOCK is low.
- Power is applied to the device.
- The POR functions have been completed.
- The temperature index timer reaches a 1ms time period.
- Registers CONFIG, OTCDAC, and FSOTCDAC are refreshed from EEPROM.

- Registers ODAC and FSODAC are refreshed from the temperature indexed EEPROM locations.

### Calibration Operation, Registers Updated by Serial Communications:

- The MAX1455 has not had the Secure-Lock byte set (CL[7:0] = 00hex) or UNLOCK is high.
- Power is applied to the device.
- The POR functions have been completed.
- The registers can then be loaded from the serial digital interface by use of serial commands. See the section on serial I/O and commands.



# Low-Cost Precision Sensor Signal Conditioner

MAX1455

## Internal EEPROM

The internal EEPROM is organized as a 768 by 8-bit memory. It is divided into 12 pages, with 64 bytes per page. Each page can be individually erased. The memory structure is arranged as shown in Table 1. The look-up tables for ODAC and FSODAC are also shown, with the respective temperature index pointer. Note that the ODAC table occupies a continuous segment, from address 000hex to address 15Fhex, whereas the FSODAC table is divided in two parts, from 200hex to 2FFhex, and from 1A0hex to 1FFhex. With the exception of the general-purpose user bytes, all values are 16-bit-wide words formed by two adjacent byte locations (high byte and low byte).

The MAX1455 compensates for sensor offset, FSO, and temperature errors by loading the internal calibration registers with the compensation values. These compensation values can be loaded to registers directly through the serial digital interface during calibration or loaded automatically from EEPROM at power-on. In this way, the device can be tested and configured during calibration and test and the appropriate compensation values stored in internal EEPROM. The device autoloading the registers from EEPROM and is ready for use without further configuration after each power-up. The EEPROM is configured as an 8-bit-wide array so each of the 16-bit registers is stored as two 8-bit quantities. The Configuration register, FSOTCDAC, and OTCDAC registers are loaded from the preassigned locations in the EEPROM. Table 2 is the EEPROM ODAC and FSODAC lookup table memory map.

The ODAC and FSODAC are loaded from the EEPROM lookup tables using an index pointer that is a function of temperature. An ADC converts the integrated temperature sensor to an 8-bit value every 1ms. This digitized value is then transferred into the Temp-Index register. Table 3 lists the registers.

The typical transfer function for the temp-index is as follows:

$$\text{temp-index} = 0.69 \times \text{Temperature } (^{\circ}\text{C}) + 47.58$$

where temp-index is truncated to an 8-bit integer value. Typical values for the Temp-Index register are given in Table 4.

Note that the EEPROM is 1 byte wide and the registers that are loaded from EEPROM are 16 bits wide. Thus, each index value points to 2 bytes in the EEPROM.

Maxim programs all EEPROM locations to FFhex with the exception of the oscillator frequency setting and Secure-Lock byte. OSC[2:0] is in the Configuration register (Table 5). These bits should be maintained at the factory-preset values. Programming 00hex in the

Secure-Lock byte (CL[7:0] = 00hex) configures the DIO as an asynchronous serial input for calibration and test purposes.

## MAX1455 Digital Mode

A single-pin serial interface provided by the DIO accesses the MAX1455's control functions and memory. All command inputs to this pin flow into a set of 16 registers, which form the interface register set (IRS). Additional levels of command processing are provided by control logic, which takes its inputs from the IRS. A bidirectional 16-bit latch buffers data to and from the 16-bit Calibration registers and internal (8-bit-wide) EEPROM locations. Figure 5 shows the relationship between the various serial commands and the MAX1455 internal architecture.

## Communication Protocol

The DIO serial interface is used for asynchronous serial data communications between the MAX1455 and a host calibration test system or computer. The MAX1455 automatically detects the baud rate of the host computer when the host transmits the initialization sequence. Baud rates between 4800 and 38400 can be detected and used. The data format is always 1 start bit, 8 data bits, and 1 stop bit. The 8 data bits are transmitted LSB first, MSB last. A weak pullup resistor can be used to maintain logic 1 on the DIO pin while the MAX1455 is in digital mode. This is to prevent unintended 1 to 0 transitions on this pin, which would be interpreted as a communication start bit. Communications are only allowed when the Secure-Lock byte is disabled (i.e., CL[7:0] = 00HEX ) or UNLOCK is held high. Table 8 is the control location.

## Initialization Sequence

The first Command Byte sent to the MAX1455 after power-up, or following receipt of the reinitialization command, is used by the MAX1455 to learn the communication baud rate. The initialization sequence is a 1-byte transmission of 01 hex, as follows:

1 1 1 1 1 **0** 1 0 0 0 0 0 0 0 **1** 1 1 1 1 1

The start bit, shown in bold above, initiates the baud rate synchronization. The 8 data bits 01hex (LSB first) follow this and then the stop bit, also shown in bold above. The MAX1455 uses this sequence to calculate the time interval for a 1-bit transmission as a multiple of the period of its internal oscillator. The resulting number of oscillator clock cycles is then stored internally as an 8-bit number (BITCLK). Note that the device power supply should be stable for a minimum period of 1ms before the initialization sequence is sent. This allows time for the POR function to complete and DIO to be configured by the Secure-Lock byte or UNLOCK.

# Low-Cost Automotive Sensor Signal Conditioner

Table 1. EEPROM Memory Address Map

PAGE	LOW-BYTE ADDRESS (hex)	HIGH-BYTE ADDRESS (hex)	TEMP-INDEX[7:0] (hex)	CONTENTS	
0	000	001	00	ODAC Lookup Table	
	03E	03F	1F		
1	040	041	20		
	07E	07F	3F		
2	080	081	40		
	0BE	0BF	5F		
3	0C0	0C1	60		
	0FE	0FF	7F		
4	100	101	80		
	13E	13F	9F		
5	140	141	A0		
	15E	15F	AF to FF		
	160	161			Configuration
	162	163			Reserved
	164	165			OTCDAC
	166	167			Reserved
	168	169		FSOTCDAC	
	16A	16B		Control Location	
	16C	16D		52 General-Purpose User Bytes	
	17E	17F			
6	180	181			
	19E	19F			
	1A0	1A1	80		
7	1BE	1BF	8F		
	1C0	1C1	90		
8	1FE	1FF	AF to FF		
	200	201	00	FSODAC Lookup Table	
9	23E	23F	1F		
	240	241	20		
A	27E	27F	3F		
	280	281	40		
B	2BE	2BF	5F		
	2C0	2C1	60		
	2FE	2FF	7F		

# Low-Cost Automotive Sensor Signal Conditioner

MAX1455

**Table 2. EEPROM ODAC and FSODAC Lookup Table Memory Map**

TEMP-INDEX[7:0]	EEPROM ADDRESS ODAC LOW BYTE AND HIGH BYTE	EEPROM ADDRESS FSODAC LOW BYTE AND HIGH BYTE
00hex to 7Fhex	000hex and 001hex to 0FEhex and 0FFhex	200hex and 201hex to 2FEhex and 2FFhex
80hex to AFhex	100hex and 101hex to 15Ehex and 15Fhex	1A0hex and 1A1hex to 1FEhex and 1FFhex

**Table 3. Registers**

REGISTER	DESCRIPTION
CONFIG	Configuration register
ODAC	Offset DAC register
OTCDAC	Offset temperature coefficient DAC register
FSODAC	Full-span output DAC register
FSOTCDAC	Full-span output temperature coefficient DAC register

**Table 4. Temp-Index Typical Values**

TEMPERATURE (°C)	TEMP-INDEX[7:0]	
	DECIMAL	HEXADECIMAL
-40	20	14
+25	65	41
+85	106	6A
+125	134	86

### Reinitialization Sequence

The MAX1455 provides for reestablishing, or relearning, the baud rate. The reinitialization sequence is a 1-byte transmission of FFhex, as follows:

1 1 1 1 1 0 1 1 1 1 1 1 1 1 1 1 1 1

When a serial reinitialization sequence is received, the receive logic resets itself to its power-up state and waits for the initialization sequence. The initialization sequence must follow the reinitialization sequence in order to reestablish the baud rate.

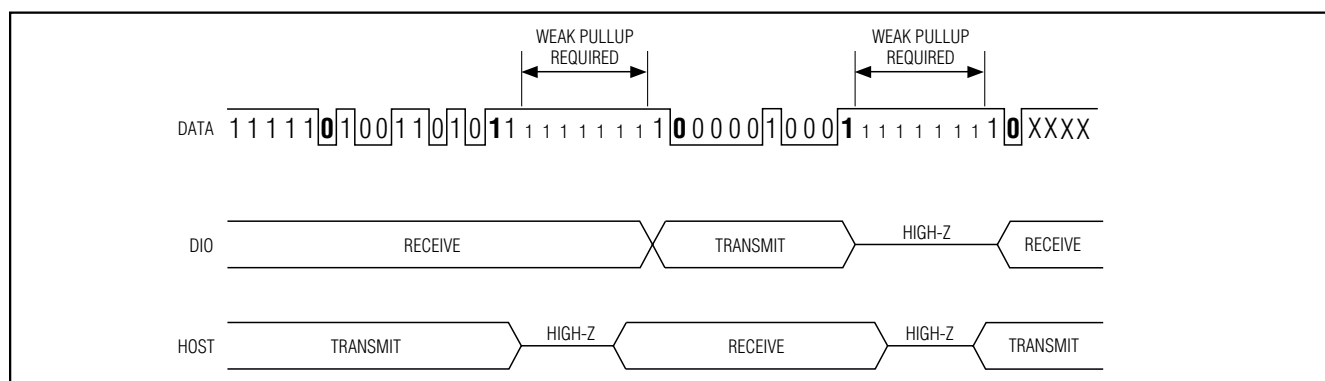

Figure 4. DIO Output Data Format

# Low-Cost Automotive Sensor Signal Conditioner

**Table 5. Configuration Register (CONFIG[15:0])**

FIELD	NAME	DESCRIPTION
15:13	OSC[2:0]	Oscillator frequency setting. <b>Factory preset; do not change.</b>
12:11	CLIP[1:0]	Sets output clip levels.
10	PGA Sign	Logic 1 inverts INM and INP polarity (Table 6).
9	IRO Sign	Logic 1 for positive input-referred offset (IRO). Logic 0 for negative IRO.
8:6	IRO[2:0]	Input-referred coarse-offset adjustment (Table 7).
5:2	PGA[3:0]	Programmable-gain amplifier setting.
1	ODAC Sign	Logic 1 for positive offset DAC output. Logic 0 for negative offset DAC output.
0	OTCDAC Sign	Logic 1 for positive offset TC DAC output. Logic 0 for negative offset TC DAC output.

**Table 6. PGA Gain Setting (PGA[3:0])**

PGA[3:0]	PGA GAIN (V/V)
0000	39
0001	52
0010	65
0011	78
0100	91
0101	104
0110	117
0111	130
1000	143
1001	156
1010	169
1011	182
1100	195
1101	208
1110	221
1111	234

### Serial Interface Command Format

All communication commands into the MAX1455 follow the format of a start bit, 8 command bits (command byte), and a stop bit. The Command Byte controls the

contents of the IRS and comprises a 4-bit interface register set address (IRSA) nibble and a 4-bit interface register set data (IRSD) nibble. The IRS Command Byte is structured as follows:

$$\text{IRS}[7:0] = \text{IRSD}[3:0], \text{IRSA}[3:0]$$

All commands are transmitted LSB first. The first bit following the start bit is IRSA[0] and the last bit before the stop bit is IRSD[3] as follows:

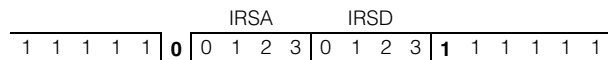

Half of the register contents of the IRS are used for data hold and steering information. Data writes to two locations within the IRS cause immediate action (command execution). These locations are at addresses 9 and 15 and are the Command Register to Internal Logic (CRIL) and reinitialize commands, respectively. Table 9 shows a full listing of IRS address decoding.

Command sequences can be written to the MAX1455 as a continuous stream, i.e., start bit, command byte, stop bit, start bit, command byte, stop bit, etc. There are no delay requirements between commands while the MAX1455 is receiving data.

### Command Register to Internal Logic

A data write to the CRIL location (IRS address 9) causes immediate execution of the command associated with the 4-bit data nibble written. All EEPROM and Calibration register read and write, together with EEPROM erase, commands are handled through the CRIL location. CRIL is also used to enable the MAX1455 analog output and to place output data (serial digital output) on DIO. Table 10 shows a full listing of CRIL commands.

# Low-Cost Automotive Sensor Signal Conditioner

**MAX1455**

**Table 7. Input Referred Offset (IRO[2:0])**

IRO SIGN, IRO[2:0]	INPUT-REFERRED OFFSET CORRECTION AS % OF V <sub>DD</sub>	INPUT-REFERRED OFFSET, CORRECTION AT V <sub>DD</sub> = 5VDC IN mV
1,111	+1.25	+63
1,110	+1.08	+54
1,101	+0.90	+45
1,100	+0.72	+36
1,011	+0.54	+27
1,010	+0.36	+18
1,001	+0.18	+9
1,000	0	0
0,000	0	0
0,001	-0.18	-9
0,010	-0.36	-18
0,011	-0.54	-27
0,100	-0.72	-36
0,101	-0.90	-45
0,110	-1.08	-54
0,111	-1.25	-63

### Serial Digital Output

DIO is configured as a digital output by writing a Read IRS (RDIRS) command (5 hex) to the CRIL location. On receipt of this command, the MAX1455 outputs a byte of data, the contents of which are determined by the IRS pointer (IRSP[3:0]) value at location IRSA[3:0] = 8hex. The data is output as a single byte, framed by a start bit and a stop bit. Table 11 lists the data returned for each IRSP address value.

Once the RDIRS command has been sent, all connections to DIO must be three-stated to allow the MAX1455 to drive the DIO line. Following receipt of the RDIRS command, the MAX1455 drives DIO high after 1 byte time. The MAX1455 holds DIO high for a single bit time and then asserts a start bit (drives DIO low). The start bit is then followed by the data byte and a stop bit. Immediately following transmission of the stop bit, the MAX1455 three-states DIO, releasing the line. The MAX1455 is then ready to receive the next command sequence 1 byte time after release of DIO.

Note that there are time intervals before and after the MAX1455 sends the data byte when all devices on the DIO line are three-stated. It is recommended that a weak pullup resistor be applied to the DIO line during these time intervals to prevent unwanted transitions (Figure 4). In applications where DIO and analog output (OUT) are not connected, a pullup resistor should be permanently connected to DIO. If the MAX1455 DIO and analog outputs are connected, then do not load this common line during analog measurements. In this situation, perform the following sequence:

- 1) Connect a pullup resistor to the DIO/OUT line, preferably with a relay.
- 2) Send the RDIRS command.
- 3) Three-state the user connection (set to high impedance).
- 4) Receive data from the MAX1455.
- 5) Activate the user connection (pull DIO/OUT line high).
- 6) Release the pullup resistor.

# Low-Cost Automotive Sensor Signal Conditioner

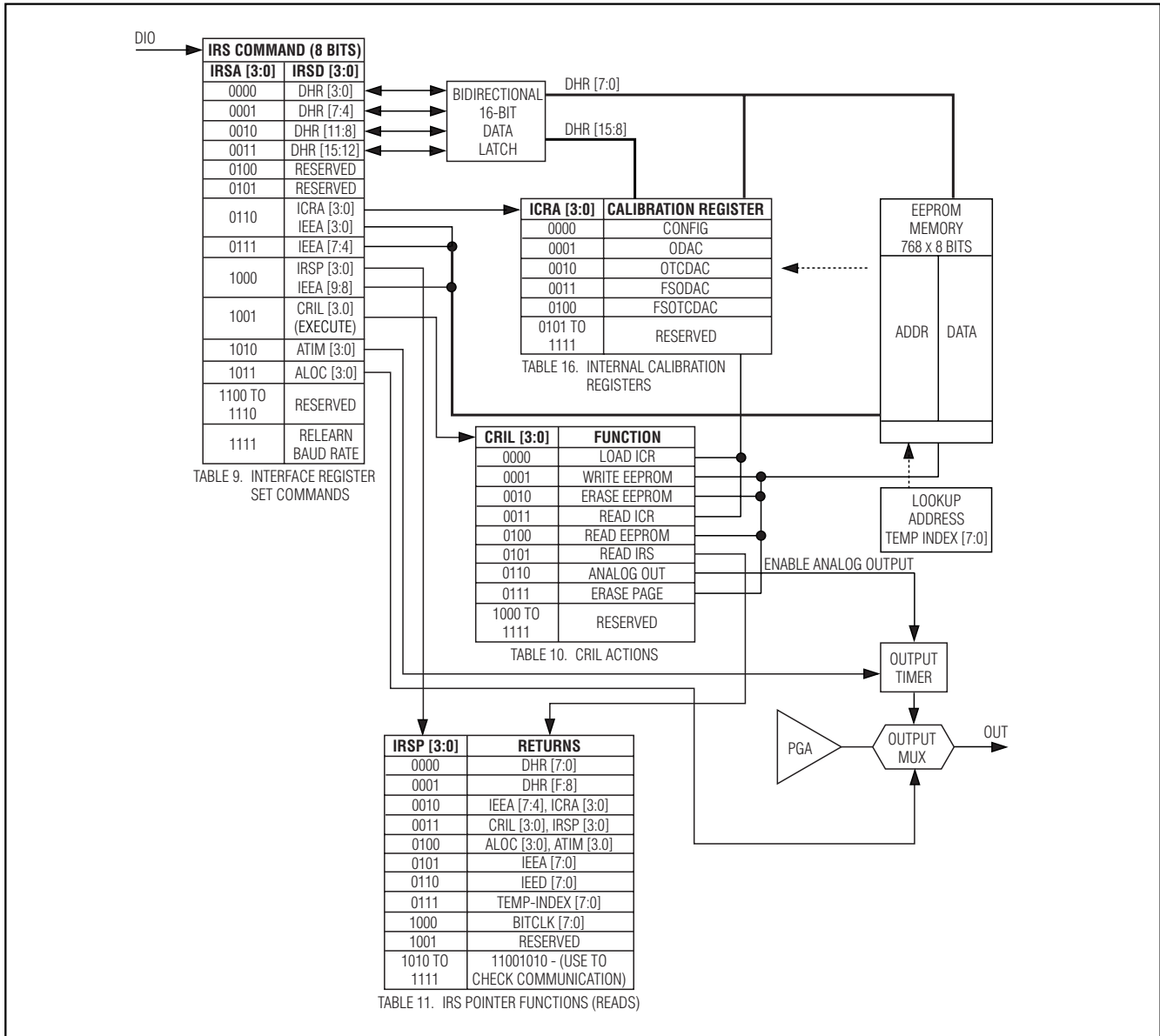

Figure 5. MAX1455 Serial Command Structure and Hardware Schematic

Figure 4 shows an example transmit/receive sequence with the RDIRS command (59hex) being sent and the MAX1455 responding with a byte value of 10hex.

### Internal Clock Settings

Following initial power-up, or after a power reset, all of the calibration registers within the MAX1455 contain 0000hex and must be programmed. Note that in analog

mode, the internal registers are automatically refreshed from the EEPROM.

When starting the MAX1455 in digital mode, pay special attention to the 3 CLK bits: 3MSBs of the Configuration register. The frequency of the MAX1455 internal oscillator is measured during production testing and a 3-bit adjustment (calibration) code is calculated

# Low-Cost Automotive Sensor Signal Conditioner

**Table 8. Control Location (CL[15:0])**

FIELD	NAME	DESCRIPTION
15:8	CL[15:8]	Reserved
7:0	CL[7:0]	Control Location. Secure-Lock is activated by setting this to FFhex, which disables DIO serial communications and connects OUT to PGA output.

**Table 9. IRSA Decoding**

IRSA[3:0]	DESCRIPTION
0000	Write IRSD[3:0] to DHR[3:0] (Data Hold register)
0001	Write IRSD[3:0] to DHR[7:4] (Data Hold register)
0010	Write IRSD[3:0] to DHR[11:8] (Data Hold register)
0011	Write IRSD[3:0] to DHR[15:12] (Data Hold register)
0100	Reserved
0101	Reserved
0110	Write IRSD[3:0] to ICRA[3:0] or IEEA[3:0] (Internal Calibration register address or internal EEPROM address nibble 0)
0111	Write IRSD[3:0] to IEEA[7:4] (internal EEPROM address, nibble 1)
1000	Write IRSD[3:0] to IRSP[3:0] or IEEA[9:8] (Interface register set pointer where IRSP[1:0] is IEEA[9:8])
1001	Write IRSD[3:0] to CRIL[3:0] (Command register to internal logic)
1010	Write IRSD[3:0] to ATIM[3:0] (analog timeout value on read)
1011	Write IRSD[3:0] to ALOC[3:0] (analog location)
1100 to 1110	Reserved
1111	Write IRSD[3:0] = 1111bin to relearn the baud rate

and stored in the upper 3 bits of EEPROM location 161hex (EEPROM upper configuration byte).

The MAX1455 internal clock controls timing functions, including the signal path gain, DAC functions, and communications. It is recommended that, while in digital mode, the Configuration register CLK bits be assigned the values contained in EEPROM (upper configuration byte). The 3 CLK bits represent a two's-complement number with a nominal clock adjustment of 9% per bit. Table 12 shows the codes and adjustment available.

Any change to the CLK bit values contained in the Configuration register must be followed by the MAX1455 baud rate learning sequence (reinitialize and initialize commands). To maximize the robustness of the communication system during clock resetting only, change the CLK bits by 1LSB value at a time. The rec-

ommended setting procedure for the Configuration register CLK bits is, therefore, as follows. (Use a minimum baud rate of 9600 during the setting procedure to prevent potential overflow of the MAX1455 baud rate counter with clock values near maximum.)

The following example is based on a required CLK code of 010 binary:

- 1) Read the CLK bits (3MSBs) from EEPROM location 161hex. CLK = 010 binary.
- 2) Set the CLK bits in the Configuration register to 001 binary.
- 3) Send the reinitialize command, followed by the initialize (baud rate learning) command.
- 4) Set the CLK bits in the Configuration register to 010 binary.

# Low-Cost Automotive Sensor Signal Conditioner

**Table 10. CRIL Command Codes**

CRIL[3:0]	NAME	DESCRIPTION
0000	LdICR	Load Internal Calibration register at address given in ICRA with data from DHR[15:0].
0001	EEPW	EEPROM write of 8 data bits from DHR[7:0] to address location pointed by IEEA [9:0].
0010	ERASE	Erase all of EEPROM (all bytes equal FFhex).
0011	RdICR	Read Internal Calibration register as pointed to by ICRA and load data into DHR[15:0].
0100	RdEEP	Read internal EEPROM location and load data into DHR[7:0] pointed by IEEA [9:0].
0101	RdIRS	Read Interface register set pointer IRSP[3:0]. See Table 11.
0110	RdAlg	Output the multiplexed analog signal onto OUT. The analog location is specified in ALOC[3:0] (Table 13) and the duration (in byte times) that the signal is asserted onto the pin is specified in ATIM[3:0] (Table 14).
0111	PageErase	Erases the page of the EEPROM as pointed by IEEA[9:6]. There are 64 bytes per page and thus 12 pages in the EEPROM.
1000 to 1111	Reserved	Reserved.

- 5) Send the reinitialize command, followed by the initialize (baud rate learning) command.

The frequency of the internal oscillator can be checked at any time by reading the value of BITCLK[7:0]. This 8-bit number represents the number of internal oscillator cycles corresponding to 1 cycle (1 bit time) of the communications baud rate.

### Erasing and Writing to the EEPROM

The internal EEPROM must be erased (bytes set to FFhex) prior to programming the desired contents. The MAX1455 is supplied in a nominally erased state except byte 161hex and byte 16Bhex. The 3MSBs of byte 161hex contain the internal oscillator calibration setting. Byte 16Bhex is set to 00hex to allow serial communication regardless of the UNLOCK status.

When erasing the EEPROM, first save the 3MSBs of byte 161hex. Following erasure, these 3 bits must be rewritten, together with the Secure-Lock byte value of 00hex. Failure to do this may cause the part to stop communicating. **Do not remove power from the device before rewriting these values.**

The internal EEPROM can be entirely erased with the ERASE command or partially erased with the PageErase command (Table 10). It is necessary to wait 7.1ms after issuing an erase or PageErase command. Any attempt to communicate with the part or to interrupt power before 7.1ms have elapsed may produce indeterminate states within the EEPROM.

To erase a page in EEPROM (PageErase command): First load the required page number (Table 1) into the IRS location IEEA[3:0]. Then send a CRIL PageErase command (79hex).

To write a byte to EEPROM: Load IRS locations IEEA[9:8], IEEA[7:4], and IEEA[3:0] with the byte address (Address[9:0]). Load IRS locations DHR[7:4] and DHR[3:0] with the 8 data bits to be written (Data[7:0]). Send the EEPROM WRITE command to CRIL (19hex).

To read a byte from EEPROM:

- 1) Load IRS locations IEEA[9:8], IEEA[7:4], and IEEA[3:0] with the byte address (Address[9:0]).
- 2) Send a READ EEPROM command to the CRIL register (49hex); this loads the required EEPROM byte into DHR[7:0].
- 3) Load IRS location IRSP[3:0] with 00hex (return DHR[7:0]).
- 4) Send the READ IRSP command to the CRIL register (59hex).

### Multiplexed Analog Output

The MAX1455 provides the facility to output analog signals while in digital mode through the read analog (RdAlg) command. One byte time after receiving the RdAlg command, the internal analog signal determined by the ALOC[3:0] register (Table 13) is multiplexed to the MAX1455 OUT. The signal remains connected to OUT for the duration set by the ATIM[3:0] register. The



# Low-Cost Automotive Sensor Signal Conditioner

**Table 11. IRSP Decode**

IRSP[3:0]	RETURNED VALUE
0000	DHR[7:0]
0001	DHR[15:8]
0010	IEEA[7:4], ICRA[3:0] concatenated
0011	CRIL[3:0], IRSP[3:0] concatenated
0100	ALOC[3:0], ATIM[3:0] concatenated
0101	IEEA[7:0] EEPROM address byte
0110	IEED[7:0] EEPROM data byte
0111	Temp-Index[7:0]
1000	BitClock[7:0]
1001	Reserved. Internal flash test data.
1010-1111	11001010 (CAhex). This can be used to test communication.

**Table 12. CLK Code (3MSBs of Configuration Register)**

CLK CODE (BIN)	CLOCK ADJUSTMENT (%)
011	+27
010	+18
001	+9
000	0
111	-9
110	-18
101	-27

ATIM function uses the communication baud rate as a timing basis. See Table 14 for details. At the end of the period determined by ATIM[3:0], the analog signal is disconnected from the analog output and OUT resumes a three-state condition. The MAX1455 can receive further commands on DIO 1 byte after resuming a three-state condition on OUT. Figure 6 shows the timing of this scheme.

The MAX1455 DIO is three-state for the duration that the analog output is active. This is to allow OUT and DIO to be connected in parallel. When DIO and OUT are connected in parallel, the host computer must also three-state its communications connection to the MAX1455. This requirement produces periods when all connections to the DIO are three-stated simultaneously, making it necessary to have a weak pullup resistor applied to DIO during these periods.

A continuous output mode is available for the analog output and is selected by setting ATIM[3:0] to Fhex. This mode may only be used when DIO and OUT are separate. While in this mode and following receipt of the RdAlG command, or any other command, DIO three-states for a period of 32,769 byte times. Once this period has elapsed, DIO enters receive mode and accepts further command inputs. The analog output is always active while in continuous mode.

**Note:** The internal analog signals are not buffered when connected to OUT. Any loading of OUT while one of these internal signals is being measured is likely to produce measurement errors. **Do not load OUT when reading internal signals such as BDR, FSOTC, etc.**

**Communication Command Examples**

A selection of examples of the command sequences for various functions within the MAX1455 follows.

**Example 1.** Change the baud rate setting and check communications. If the communication with the MAX1455 is lost due to a system baud rate change before sending the reinitialization command, apply a power reset to guarantee the initialization condition.

COMMAND	ACTION
FFhex	Reinitialize part ready for baud rate learning.
	Change system baud rate to new value.
01hex	Learn baud rate.
F8hex	Load 15 (Fhex) to IRSP[3:0] register.
59hex	Read IRS.
	Host computer must be ready to receive data on the serial line within 1 (baud rate) byte time of sending the Read IRS command. The MAX1455 returns CAhex. (IRSP values of 10 to 15 are configured to return CAhex for communication checking purposes.)

# Low-Cost Automotive Sensor Signal Conditioner

**Example 2.** Read the lookup table pointer (Temp-Index).

COMMAND	ACTION
78hex	Load 7 to IRSP[3:0] register.
59hex	Read IRS.
	Host ready to receive data within 1 byte time of sending the Read IRS command. The MAX1455 returns the current Temp-Index pointer value.

**Example 3.** Enable BDR measurement on OUT pin for 3.4s duration with 9600 baud rate.

COMMAND	ACTION
1Bhex	Load 1 (BDR measurement) to ALOC[3:0] register.
CAhex	Load 12 to the ATIM[3:0] register: $(2^{12}+1) \times 8/9600 = 3.4s$ .
69hex	RdAlg.
	The DIO pin is three-stated and the OUT pin is connected internally to the BDR pin for a duration of approximately 3.4s.

**Example 4.** Write 8C40hex to the FSODAC register.

COMMAND	ACTION
00hex	Load 0 hex to the DHR[3:0] register.
41hex	Load 4 hex to the DHR[7:4] register.
C2hex	Load C hex to the DHR[11:8] register.
83hex	Load 8 hex to the DHR[15:12] register.
36hex	Load 3 (FSODAC) to the ICRA[3:0] register.
09hex	Ld ICR.
	8C40 hex is written to the FSODAC register.

**Example 5.** Write 8C40hex to the FSODAC lookup table location at Temp-Index 40. This example uses the Page Erase command to clear the relevant section of the EEPROM and assumes that none of the existing data in that section is required to be kept.

COMMAND	ACTION
A6hex	Load Ahex (page number corresponding to EEPROM locations 280hex and 281hex) to the IEEA[3:0] register.
79hex	Page Erase command.
	Wait 7.1ms before sending any further commands.
06hex	Load 0hex to the IEEA[3:0] register.
87hex	Load 8hex to the IEEA[7:4] register.
28hex	Load 2hex to the IEEA[9:8] (IRSP[3:0]) register.
00hex	Load 0hex to the DHR[3:0] register.
41hex	Load 4hex to the DHR[7:4] register.
19hex	Write EEPROM. 40hex is loaded to EEPROM address 280hex, which is the low byte location corresponding to a Temp-Index pointer value of 40.
16hex	Load 1 to the IEEA[3:0] register. IEEA[7:4] and IEEA[9:8] already contain 8 and 2, respectively.
C0hex	Load Chex to the DHR[3:0] register.
81hex	Load 8hex to the DHR[7:4] register.
19hex	Write EEPROM. 8Chex is loaded to EEPROM address 281hex, which is the high byte location corresponding to a Temp-Index pointer value of 40.

# Low-Cost Automotive Sensor Signal Conditioner

MAX1455

**Table 13. ALOC Definition**

ALOC[3:0]	ANALOG SIGNAL	DESCRIPTION
0000	OUT	PGA Output
0001	BDR	Bridge Drive
0010	ISRC	Bridge Drive Current Setting
0011	VDD	Internal Positive Supply
0100	VSS	Internal Ground
0101	CLIP-TOP	Clip Voltage High Value
0110	CLIP-BOTTOM	Clip Voltage Low Value
0111	FSODAC	Full-Scale Output DAC
1000	FSOTCDAC	Full-Scale Output TC DAC
1001	ODAC	Offset DAC
1010	OTCDAC	Offset TC DAC
1011	VREF	Bandgap Reference Voltage (nominally 1.25V)
1100	VPTATP	Internal Test Node
1101	VPTATM	Internal Test Node
1110	INP	Sensor's Positive Input
1111	INM	Sensor's Negative Input

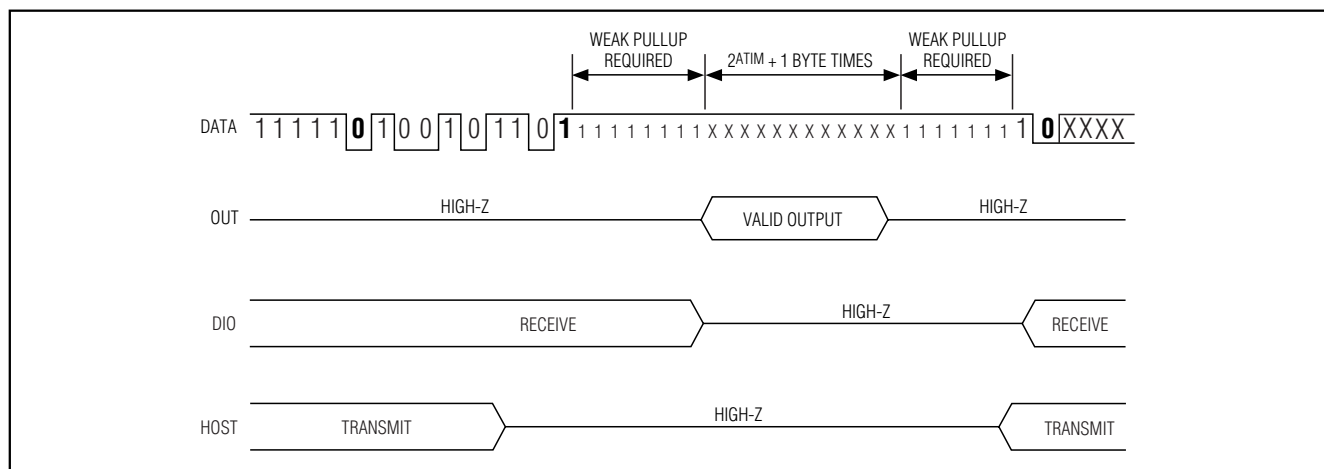

Figure 6. Analog Output Timing

# Low-Cost Automotive Sensor Signal Conditioner

**Table 14. ATIM Definition**

ATIM[3:0]	DURATION OF ANALOG SIGNAL SPECIFIED IN BYTE TIMES (8-BIT TIME)
0000	$2^0 + 1 = 2$ byte times, i.e., $(2 \times 8)$ / baud rate
0001	$2^1 + 1 = 3$ byte times
0010	$2^2 + 1 = 5$ byte times
0011	$2^3 + 1 = 9$ byte times
0100	$2^4 + 1 = 17$ byte times
0101	$2^5 + 1 = 33$ byte times
0110	$2^6 + 1 = 65$ byte times
0111	$2^7 + 1 = 129$ byte times
1000	$2^8 + 1 = 257$ byte times
1001	$2^9 + 1 = 513$ byte times
1010	$2^{10} + 1 = 1025$ byte times
1011	$2^{11} + 1 = 2049$ byte times
1100	$2^{12} + 1 = 4097$ byte times
1101	$2^{13} + 1 = 8193$ byte times
1110	$2^{14} + 1 = 16,385$ byte times
1111	In this mode, OUT is continuous; however, DIO accepts commands after 32,769 byte times. Do not parallel connect DIO to OUT.

**Table 15. ICRA Decode**

ICRA[3:0]	NAME	DESCRIPTION
0000	CONFIG	Configuration register
0001	ODAC	Offset DAC register
0010	OTCDAC	Offset temperature coefficient DAC register
0011	FSODAC	Full-scale output DAC register
0100	FSOTCDAC	Full-scale output temperature coefficient DAC register
0101		Reserved. Do not write to this location (EEPROM test).
0110 to 1111		Reserved. Do not write to this location.

### Sensor Compensation Overview

Compensation requires an examination of the sensor performance over the operating pressure and temperature range. Use a minimum of two test pressures (e.g.,

zero and full span) and two temperatures. More test pressures and temperatures result in greater accuracy. A typical compensation procedure can be summarized as follows:

# Low-Cost Automotive Sensor Signal Conditioner

**MAX1455**

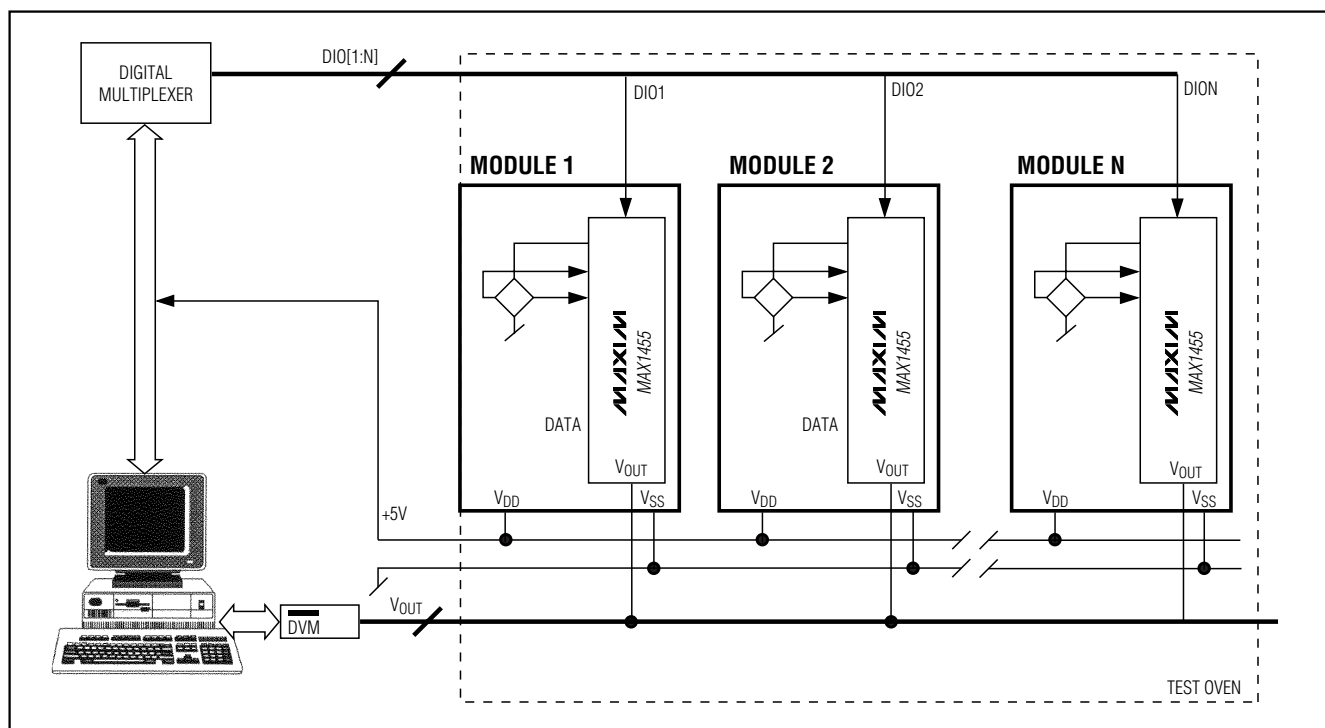

Figure 7. Automated Test System Concept

**Table 16. Effects of Compensation**

TYPICAL UNCOMPENSATED INPUT (SENSOR)	TYPICAL COMPENSATED TRANSDUCER OUTPUT
Offset..... $\pm 100\%$ FSO	OUT.....Ratiometric to $V_{DD}$ at 5.0V
FSO.....1mV/V to 40mV/V	Offset at +25°C..... $0.500V \pm 200\mu V$
Offset TC.....20% FSO	FSO at +25°C..... $4.000V \pm 200\mu V$
Offset TC Nonlinearity.....4% FSO	Offset Accuracy over Temp. Range..... $\pm 4mV (\pm 0.1\% \text{ FSO})$
FSOTC.....-20% FSO	FSO Accuracy over Temp. Range..... $\pm 4mV (\pm 0.1\% \text{ FSO})$
FSOTC Nonlinearity.....5% FSO	
Temperature Range.....-40°C to +125°C	

**Set Reference Temperature (e.g., 25°C):**

- Initialize each transducer by loading its respective register with default coefficients (e.g., based on mean values of offset, FSO, and bridge resistance) to prevent overload of the MAX1455. The internal calibration registers are addressed in ICRA[3:0] and decoded as shown in Table 15.
- Set the initial bridge voltage (with the FSODAC) to half of the supply voltage. Measure the bridge voltage using the BDR or OUT pins, or calculate based on measurements.

- Calibrate the output offset and FSO of the transducer using the ODAC and FSODAC, respectively.
- Store calibration data in the test computer or MAX1455 EEPROM user memory.

**Set Next Test Temperature:**

- Calibrate offset and FSO using the ODAC and FSODAC, respectively.
- Store calibration data in the test computer or MAX1455 EEPROM user memory.
- Calculate the correction coefficients.

# Low-Cost Automotive Sensor Signal Conditioner

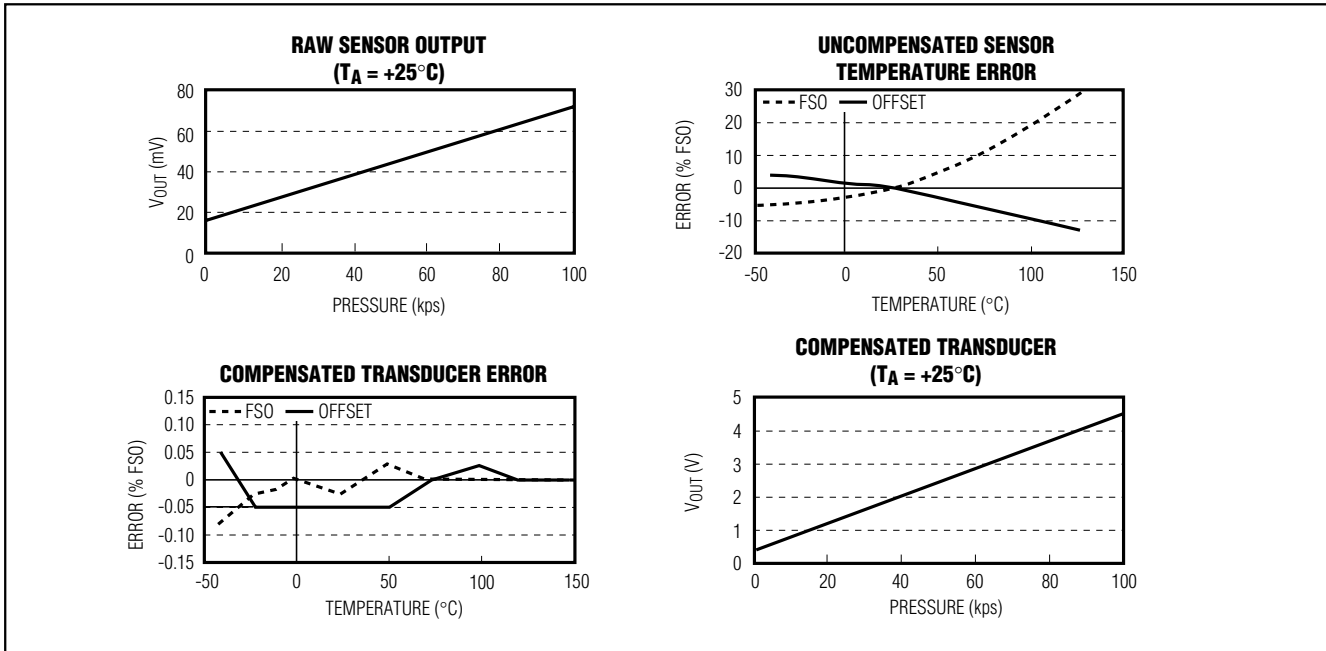

Figure 8. Comparison of an Uncalibrated Sensor and a Calibrated Transducer

- Download correction coefficients to EEPROM.
- Perform a final test.

## Sensor Calibration and Compensation Example

The MAX1455 temperature compensation design corrects both sensor and IC temperature errors. This enables the MAX1455 to provide temperature compensation approaching the inherent repeatability of the sensor. An example of the MAX1455's capabilities is shown in Figure 8. Table 16 lists the effects of compensation.

A MAX1455 and a repeatable piezoresistive sensor with an initial offset of 16.4mV and a span of 55.8mV were converted into a compensated transducer with an offset of 0.5000V and a span of 4.0000V. Nonlinear sensor offset and FSO temperature errors, which were on the order of 20% to 30% FSO, were reduced to under  $\pm 0.1\%$  FSO. Figure 8 shows the output of the uncompensated sensor and the output of the compensated transducer. Six temperature points were used to obtain this result.

## MAX1455 Evaluation Kit

To expedite the development of MAX1455-based transducers and test systems, Maxim has produced the

MAX1455 evaluation kit (EV kit). First-time users of the MAX1455 are strongly encouraged to use this kit.

The EV kit is designed to facilitate manual programming of the MAX1455 with a sensor. It includes the following:

- 1) **Evaluation board** with or without a silicon pressure sensor, ready for customer evaluation.
- 2) **Design/applications manual**. This manual was developed for test engineers familiar with data acquisition of sensor data and provides sensor compensation algorithms and test procedures.
- 3) **MAX1455 communication software**, which enables programming of the MAX1455 from a computer keyboard (IBM compatible), one module at a time.
- 4) **Interface adapter**, which allows the connection of the evaluation board to a PC serial port.

## Chip Information

TRANSISTOR COUNT: 62,242

PROCESS: CMOS

SUBSTRATE CONNECTED TO:  $V_{SS}$

# Low-Cost Automotive Sensor Signal Conditioner

## Detailed Functional Diagram

MAX1455

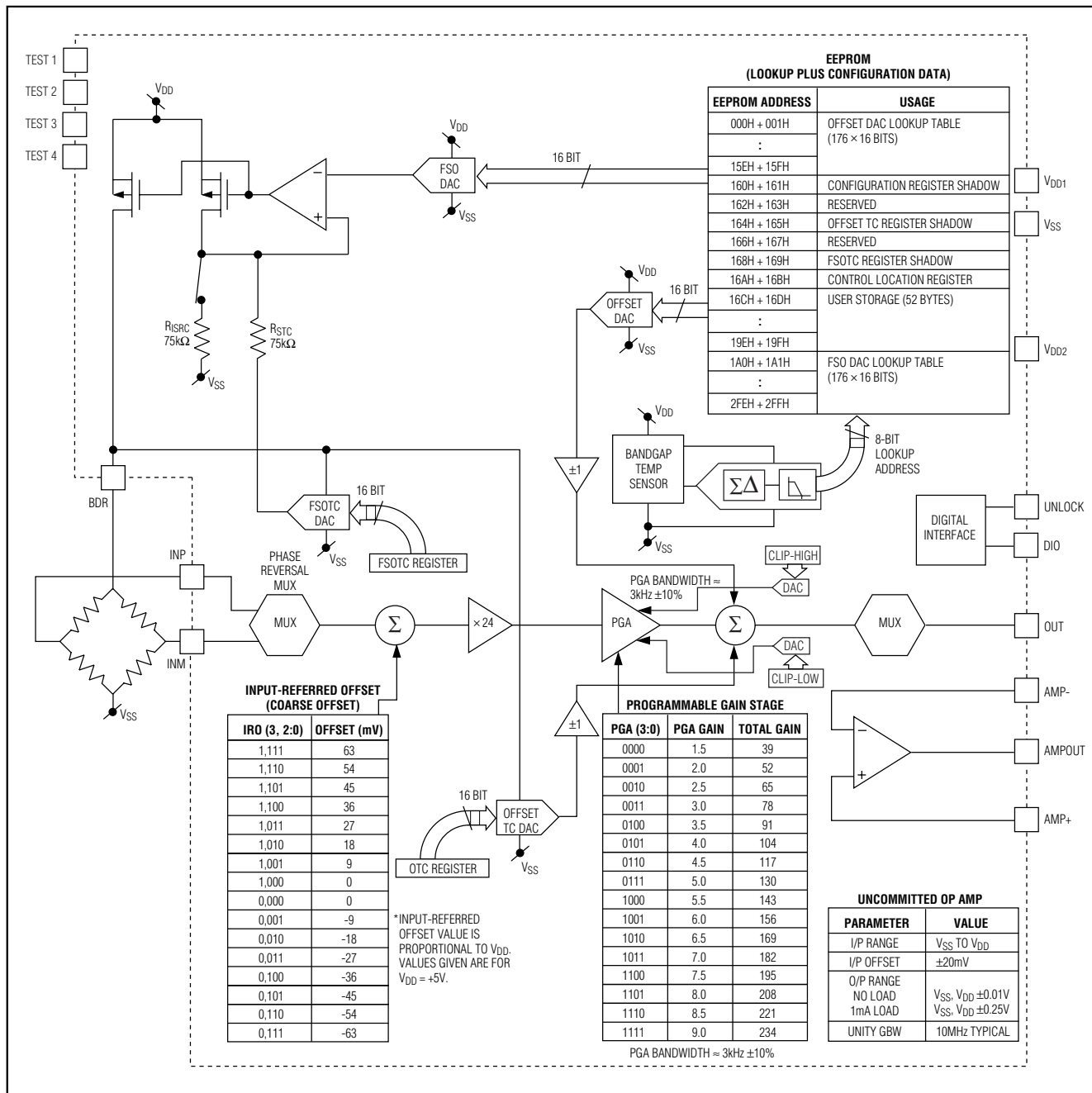

# Low-Cost Automotive Sensor Signal Conditioner

## Package Information

DIM	INCHES		MILLIMETERS	
	MIN	MAX	MIN	MAX
A	0.068	0.078	1.73	1.99
A1	0.002	0.008	0.05	0.21
B	0.010	0.015	0.25	0.38
C	0.004	0.008	0.09	0.20
D	SEE VARIATIONS			
E	0.205	0.209	5.20	5.38
e	0.0256	BSC	0.65	BSC
H	0.301	0.311	7.65	7.90
L	0.025	0.037	0.63	0.95
$\alpha$	0°	8°	0°	8°

D	INCHES		MILLIMETERS		N
	MIN	MAX	MIN	MAX	
D	0.239	0.249	6.07	6.33	14L
D	0.239	0.249	6.07	6.33	16L
D	0.278	0.289	7.07	7.33	20L
D	0.317	0.328	8.07	8.33	24L
D	0.397	0.407	10.07	10.33	28L

NOTES:

1. D&E DO NOT INCLUDE MOLD FLASH.
2. MOLD FLASH OR PROTRUSIONS NOT TO EXCEED .15mm (.006").
3. CONTROLLING DIMENSION: MILLIMETERS.
4. MEETS JEDEC MO150.

<b>MAXIM</b>		
<small>PROPRIETARY INFORMATION</small>		
<small>TITLE:</small>		
PACKAGE OUTLINE, SSOP, 5.3x.65mm		
<small>APPROVAL</small>	<small>DOCUMENT CONTROL NO.</small>	<small>REV</small>
	21-0056	B 1/1

SSOP/EPS



# Low-Cost Automotive Sensor Signal Conditioner

## Package Information (continued)

MAX1455

TSSOP, NO PADS, EPS

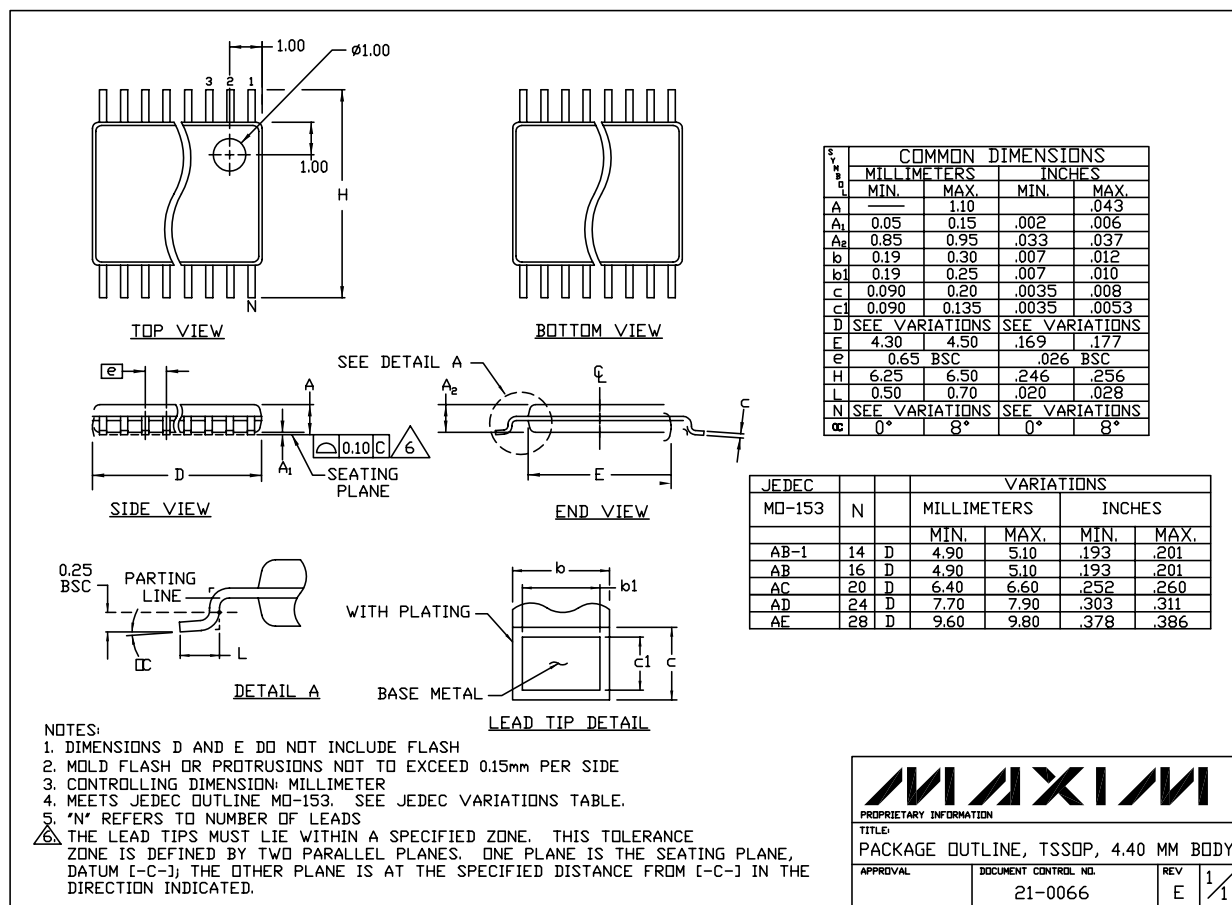

Maxim cannot assume responsibility for use of any circuitry other than circuitry entirely embodied in a Maxim product. No circuit patent licenses are implied. Maxim reserves the right to change the circuitry and specifications without notice at any time.

Maxim Integrated Products, 120 San Gabriel Drive, Sunnyvale, CA 94086 408-737-7600 25

Компания «Океан Электроники» предлагает заключение долгосрочных отношений при поставках импортных электронных компонентов на взаимовыгодных условиях!

Наши преимущества:

- Поставка оригинальных импортных электронных компонентов напрямую с производств Америки, Европы и Азии, а так же с крупнейших складов мира;
- Широкая линейка поставок активных и пассивных импортных электронных компонентов (более 30 млн. наименований);
- Поставка сложных, дефицитных, либо снятых с производства позиций;
- Оперативные сроки поставки под заказ (от 5 рабочих дней);
- Экспресс доставка в любую точку России;
- Помощь Конструкторского Отдела и консультации квалифицированных инженеров;
- Техническая поддержка проекта, помощь в подборе аналогов, поставка прототипов;
- Поставка электронных компонентов под контролем ВП;
- Система менеджмента качества сертифицирована по Международному стандарту ISO 9001;
- При необходимости вся продукция военного и аэрокосмического назначения проходит испытания и сертификацию в лаборатории (по согласованию с заказчиком);
- Поставка специализированных компонентов военного и аэрокосмического уровня качества (Xilinx, Altera, Analog Devices, Intersil, Interpoint, Microsemi, Actel, Aeroflex, Peregrine, VPT, Syfer, Eurofarad, Texas Instruments, MS Kennedy, Miteq, Cobham, E2V, MA-COM, Hittite, Mini-Circuits, General Dynamics и др.);

Компания «Океан Электроники» является официальным дистрибьютором и эксклюзивным представителем в России одного из крупнейших производителей разъемов военного и аэрокосмического назначения «JONHON», а так же официальным дистрибьютором и эксклюзивным представителем в России производителя высокотехнологичных и надежных решений для передачи СВЧ сигналов «FORSTAR».



## JONHON

«JONHON» (основан в 1970 г.)

Разъемы специального, военного и аэрокосмического назначения:

(Применяются в военной, авиационной, аэрокосмической, морской, железнодорожной, горно- и нефтедобывающей отраслях промышленности)

«FORSTAR» (основан в 1998 г.)

ВЧ соединители, коаксиальные кабели, кабельные сборки и микроволновые компоненты:

(Применяются в телекоммуникациях гражданского и специального назначения, в средствах связи, РЛС, а так же военной, авиационной и аэрокосмической отраслях промышленности).



Телефон: 8 (812) 309-75-97 (многоканальный)

Факс: 8 (812) 320-03-32

Электронная почта: [ocean@oceanchips.ru](mailto:ocean@oceanchips.ru)

Web: <http://oceanchips.ru/>

Адрес: 198099, г. Санкт-Петербург, ул. Калинина, д. 2, корп. 4, лит. А