

MAX30102

High-Sensitivity Pulse Oximeter and Heart-Rate Sensor for Wearable Health

General Description

The MAX30102 is an integrated pulse oximetry and heart-rate monitor module. It includes internal LEDs, photodetectors, optical elements, and low-noise electronics with ambient light rejection. The MAX30102 provides a complete system solution to ease the design-in process for mobile and wearable devices.

The MAX30102 operates on a single 1.8V power supply and a separate 5.0V power supply for the internal LEDs. Communication is through a standard I²C-compatible interface. The module can be shut down through software with zero standby current, allowing the power rails to remain powered at all times.

Applications

- Wearable Devices
- Fitness Assistant Devices

Benefits and Features

- Heart-Rate Monitor and Pulse Oximeter Sensor in LED Reflective Solution
- Tiny 5.6mm x 3.3mm x 1.55mm 14-Pin Optical Module
 - Integrated Cover Glass for Optimal, Robust Performance
- Ultra-Low Power Operation for Mobile Devices
 - Programmable Sample Rate and LED Current for Power Savings
 - Low-Power Heart-Rate Monitor (< 1mW)
 - Ultra-Low Shutdown Current (0.7µA, typ)
- Fast Data Output Capability
 - High Sample Rates
- Robust Motion Artifact Resilience
 - High SNR
- -40°C to +85°C Operating Temperature Range

Ordering Information appears at end of data sheet.

System Diagram

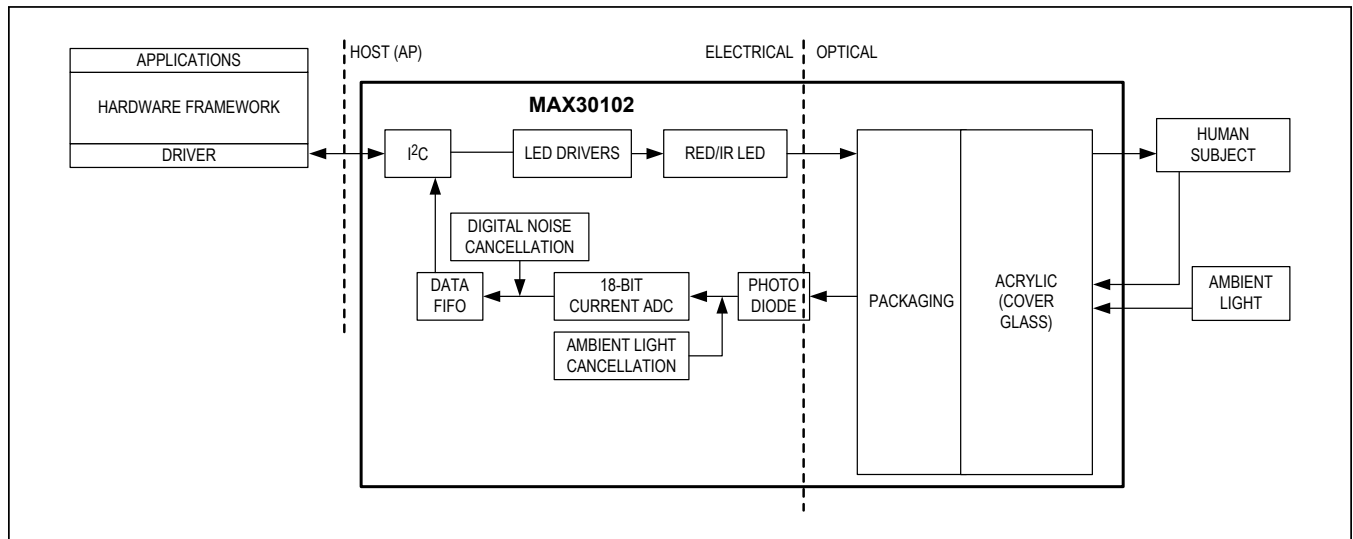

Absolute Maximum Ratings

V _{DD} to GND	-0.3V to +2.2V	Continuous Power Dissipation (T _A = +70°C)
GND to PGND	-0.3V to +0.3V	OESIP (derate 5.5mW/°C above +70°C)
X_DRV, V _{LED+} to PGND	-0.3V to +6.0V	440mW
All Other Pins to GND	-0.3V to +6.0V	Operating Temperature Range
Output Short-Circuit Current Duration	Continuous	-40°C to +85°C
Continuous Input Current into Any Terminal	±20mA	Junction Temperature
ESD, Human Body Model (HBM)	2.5kV	+90°C
Latchup Immunity	±250mA	Soldering Temperature (reflow)
		+260°C
		Storage Temperature Range
		-40°C to +105°C

Package Thermal Characteristics (Note 1)

OESIP

Junction-to-Ambient Thermal Resistance (θ _{JA})	180°C/W	Junction-to-Case Thermal Resistance (θ _{JC})	150°C/W
---	---------	--	---------

Note 1: Package thermal resistances were obtained using the method described in JEDEC specification JESD51-7, using a four-layer board. For detailed information on package thermal considerations, refer to www.maximintegrated.com/thermal-tutorial.

Electrical Characteristics

(V_{DD} = 1.8V, V_{IR_LED+} = V_{R_LED+} = 5.0V, T_A = -40°C to +85°C, unless otherwise noted. Typical values are at T_A = +25°C) (Note 2)

PARAMETER	SYMBOL	CONDITIONS	MIN	TYP	MAX	UNITS
POWER SUPPLY						
Power-Supply Voltage	V _{DD}	Guaranteed by RED and IR count tolerance	1.7	1.8	2.0	V
LED Supply Voltage R_LED+ or IR_LED+ to PGND	V _{LED+}	Guaranteed by PSRR of LED driver (R_LED+ and IR_LED+ only)	3.1	3.3	5.25	V
Supply Current	I _{DD}	SpO ₂ and HR mode, PW = 215µs, 50sps		600	1200	µA
		IR only mode, PW = 215µS, 50sps		600	1200	
Supply Current in Shutdown	I _{SHDN}	T _A = +25°C, MODE = 0x80		0.7	10	µA
PULSE OXIMETRY/HEART-RATE SENSOR CHARACTERISTICS						
ADC Resolution				18		bits
Red ADC Count (Note 3)	REDC	RED_PA = 0x0C, LED_PW = 0x01, SPO2_SR = 0x05, ADC_RGE = 0x00, T _A = +25°C	55536	65536	75536	Counts
IR ADC Count (Note 3)	IRC	IR_PA = 0x0C, LED_PW = 0x01, SPO2_SR = 0x05, ADC_RGE = 0x00, T _A = +25°C	55536	65536	75536	Counts

Electrical Characteristics (continued)(V_{DD} = 1.8V, V_{IR_LED+} = V_{R_LED+} = 5.0V, T_A = -40°C to +85°C, unless otherwise noted. Typical values are at T_A = +25°C) (Note 2)

PARAMETER	SYMBOL	CONDITIONS	MIN	TYP	MAX	UNITS
Dark Current Count	LED_DCC	RED_PA = IR_PA = 0x00, LED_PW = 0x03, SPO2_SR = 0x01 ADC_RGE = 0x02		30	128	Counts
				0.01	0.05	% of FS
DC Ambient Light Rejection	ALR	ADC counts with finger on sensor under direct sunlight (100K lux), ADC_RGE = 0x3, LED_PW = 0x03, SPO2_SR = 0x01	Red LED	2		Counts
			IR LED	2		Counts
ADC Count—PSRR (V _{DD})	PSRRV _{DD}	1.7V < V _{DD} < 2.0V, LED_PW = 0x00, SPO2_SR = 0x05 T _A = +25°C Frequency = DC to 100kHz, 100mV _{p-p}		0.25	1	% of FS
				10		LSB
ADC Count—PSRR (LED Driver Outputs)	PSRR _{LED}	3.6V < R_LED+, IR_LED+ < 5.0V, T _A = +25°C Frequency = DC to 100kHz, 100mV _{p-p}		0.05	1	% of FS
				10		LSB
ADC Clock Frequency	CLK		10.32	10.48	10.64	MHz
ADC Integration Time	INT	LED_PW = 0x00		69		µs
		LED_PW = 0x01		118		
		LED_PW = 0x02		215		
		LED_PW = 0x03		411		
Slot Timing (Timing Between Sequential Channel Samples; e.g., Red Pulse Rising Edge To IR Pulse Rising Edge)	INT	LED_PW = 0x00		427.1		µs
		LED_PW = 0x01		524.7		
		LED_PW = 0x02		720.0		
		LED_PW = 0x03		1106.6		
COVER GLASS CHARACTERISTICS (Note 4)						
Hydrolytic Resistance Class		Per DIN ISO 719		HGB 1		
IR LED CHARACTERISTICS (Note 4)						
LED Peak Wavelength	λ _P	I _{LED} = 20mA, T _A = +25°C	870	880	900	nm
Full Width at Half Max	Δλ	I _{LED} = 20mA, T _A = +25°C		30		nm
Forward Voltage	V _F	I _{LED} = 20mA, T _A = +25°C		1.4		V
Radiant Power	P _O	I _{LED} = 20mA, T _A = +25°C		6.5		mW
RED LED CHARACTERISTICS (Note 4)						
LED Peak Wavelength	λ _P	I _{LED} = 20mA, T _A = +25°C	650	660	670	nm
Full Width at Half Max	Δλ	I _{LED} = 20mA, T _A = +25°C		20		nm
Forward Voltage	V _F	I _{LED} = 20mA, T _A = +25°C		2.1		V
Radiant Power	P _O	I _{LED} = 20mA, T _A = +25°C		9.8		mW

Electrical Characteristics (continued)(V_{DD} = 1.8V, V_{IR_LED+} = V_{R_LED+} = 5.0V, T_A = -40°C to +85°C, unless otherwise noted. Typical values are at T_A = +25°C) (Note 2)

PARAMETER	SYMBOL	CONDITIONS	MIN	TYP	MAX	UNITS
PHOTODETECTOR CHARACTERISTICS (Note 4)						
Spectral Range of Sensitivity	λ (QE > 50%)	QE: Quantum Efficiency	600		900	nm
Radiant Sensitive Area	A			1.36		mm ²
Dimensions of Radiant Sensitive Area	L x W			1.38 x 0.98		mm x mm
INTERNAL DIE TEMPERATURE SENSOR						
Temperature ADC Acquisition Time	T _T	T _A = +25°C		29		ms
Temperature Sensor Accuracy	T _A	T _A = +25°C		±1		°C
Temperature Sensor Minimum Range	T _{MIN}			-40		°C
Temperature Sensor Maximum Range	T _{MAX}			85		°C
DIGITAL INPUT CHARACTERISTICS: SCL, SDA						
Input High Voltage	V _{IH}	V _{DD} = 2V	0.7 x V _{DD}			V
Input Low Voltage	V _{IL}	V _{DD} = 2V			0.3 x V _{DD}	V
Input Leakage Current	I _{IN}	V _{IN} = GND or V _{DD} (STATIC)		±0.05	±1	µA
Hysteresis Voltage	V _H			0.2		V
DIGITAL OUTPUT CHARACTERISTICS: SDA, $\overline{\text{INT}}$						
Output Low Voltage	V _{OL}	I _{SINK} = 6mA			0.2	V
I²C TIMING CHARACTERISTICS (SDA, SDA, $\overline{\text{INT}}$) (Note 5)						
I ² C Write Address				AE		Hex
I ² C Read Address				AF		Hex
Serial Clock Frequency	f _{SCL}		0		400	kHz
Bus Free Time Between STOP and START Conditions	t _{BUF}		1.3			µs
Hold Time (Repeated) START Condition	t _{HD;STA}		0.6			µs
SCL Pulse-Width Low	t _{LOW}		1.3			µs
SCL Pulse-Width High	t _{HIGH}		0.6			µs
Setup Time for a Repeated START Condition	t _{SU;STA}		0.6			µs
Data Hold Time	t _{HD;DAT}		0		900	ns

Electrical Characteristics (continued)

($V_{DD} = 1.8V$, $V_{IR_LED+} = V_{R_LED+} = 5.0V$, $T_A = -40^{\circ}C$ to $+85^{\circ}C$, unless otherwise noted. Typical values are at $T_A = +25^{\circ}C$) (Note 2)

PARAMETER	SYMBOL	CONDITIONS	MIN	TYP	MAX	UNITS
Data Setup Time	$t_{SU,DAT}$		100			ns
Setup Time for STOP Condition	$t_{SU,STO}$		0.6			μs
Pulse Width of Suppressed Spike	t_{SP}		0		50	ns
Bus Capacitance	C_B				400	pF
SDA and SCL Receiving Rise Time	t_R		$20 + 0.1C_B$		300	ns
SDA and SCL Receiving Fall Time	t_{RF}		$20 + 0.1C_B$		300	ns
SDA Transmitting Fall Time	t_{TF}				300	ns

Note 2: All devices are 100% production tested at $T_A = +25^{\circ}C$. Specifications over temperature limits are guaranteed by Maxim Integrated's bench or proprietary automated test equipment (ATE) characterization.

Note 3: Specifications are guaranteed by Maxim Integrated's bench characterization and by 100% production test using proprietary ATE setup and conditions.

Note 4: For design guidance only. Not production tested.

Note 5: Guaranteed by design and characterization. Not tested.

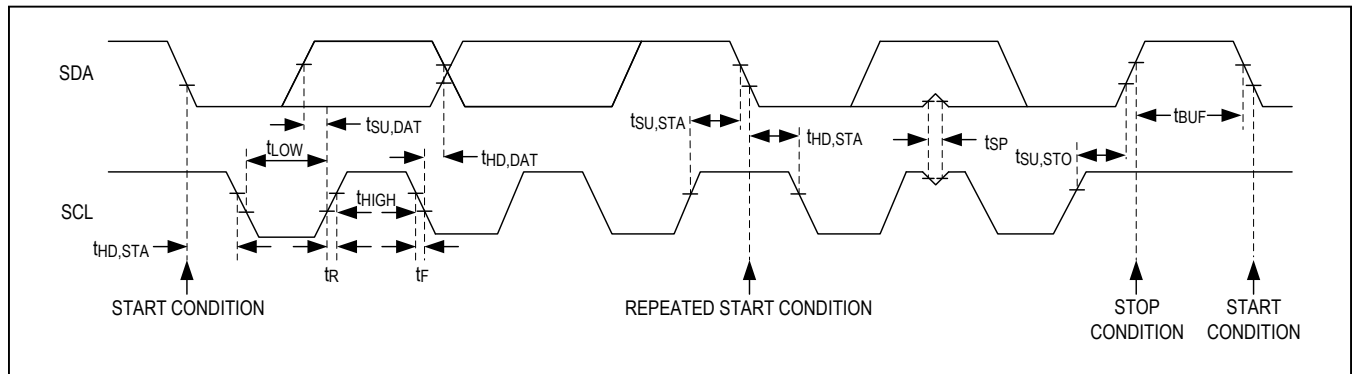
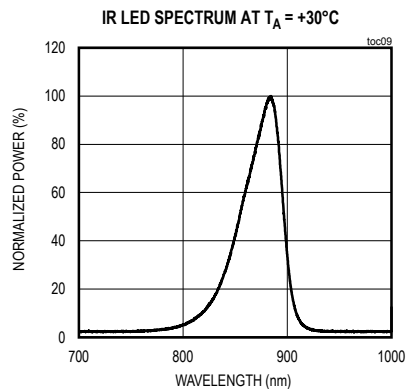
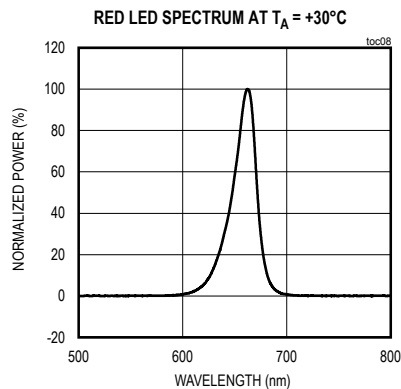
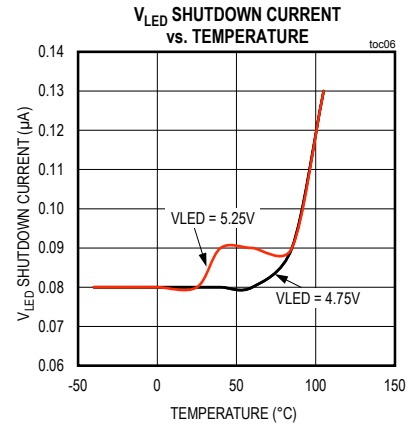
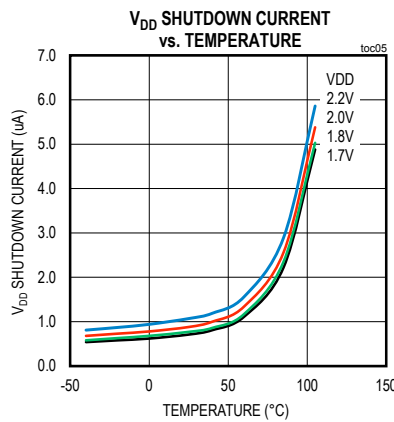
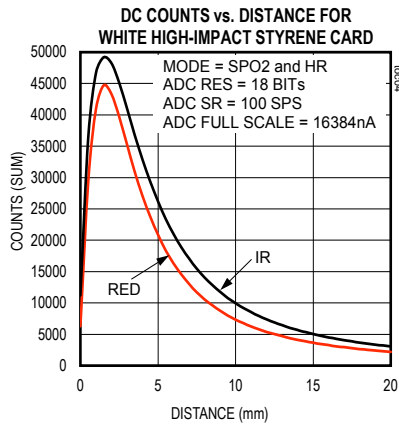
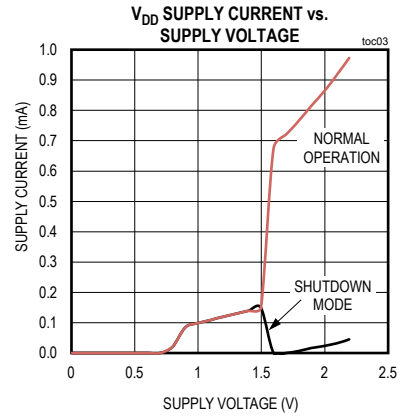
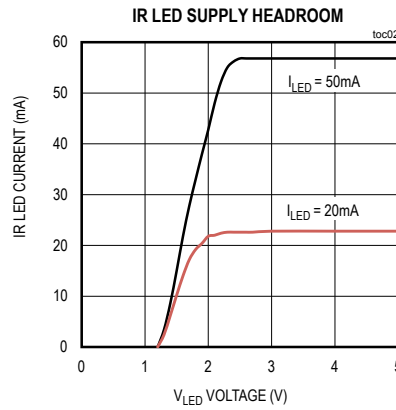
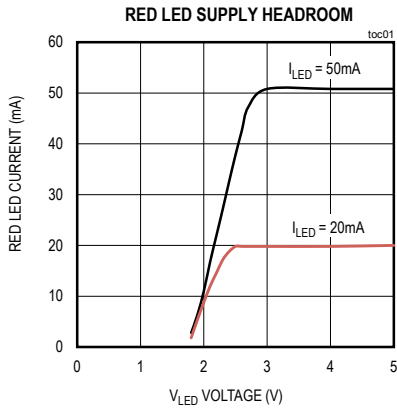

Figure 1. I²C-Compatible Interface Timing Diagram

Typical Operating Characteristics

($V_{DD} = 1.8V$, $V_{LED+} = 5.0V$, $T_A = +25^{\circ}C$, \overline{RST} , unless otherwise noted.)



Typical Operating Characteristics (continued)

($V_{DD} = 1.8V$, $V_{LED+} = 5.0V$, $T_A = +25^{\circ}C$, \overline{RST} , unless otherwise noted.)

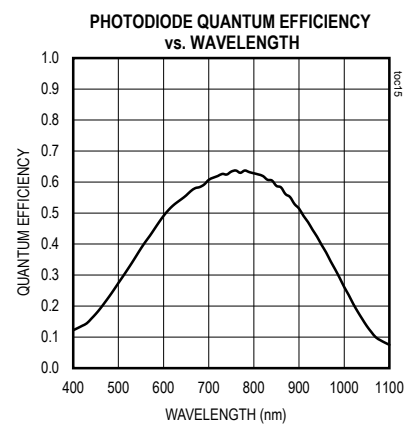
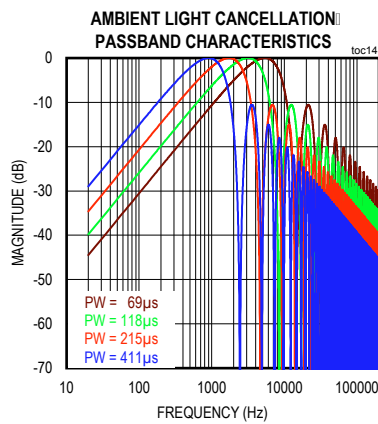
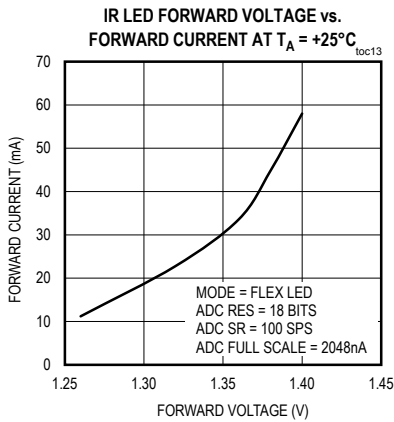
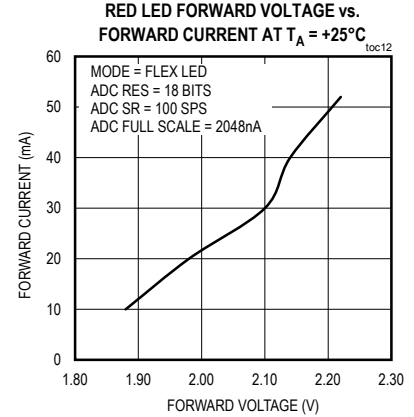
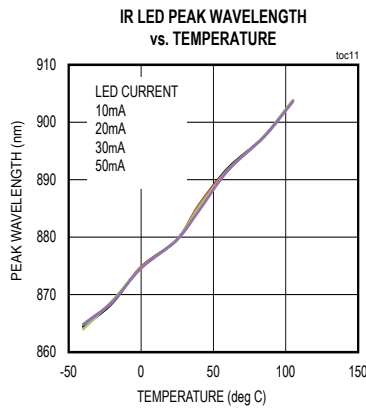
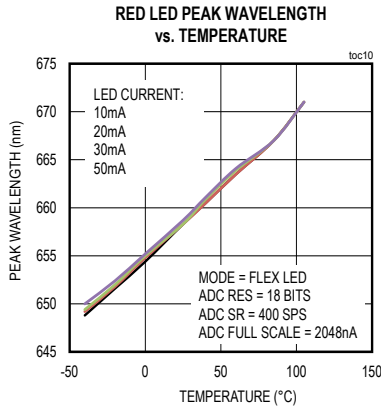

Pin Configuration

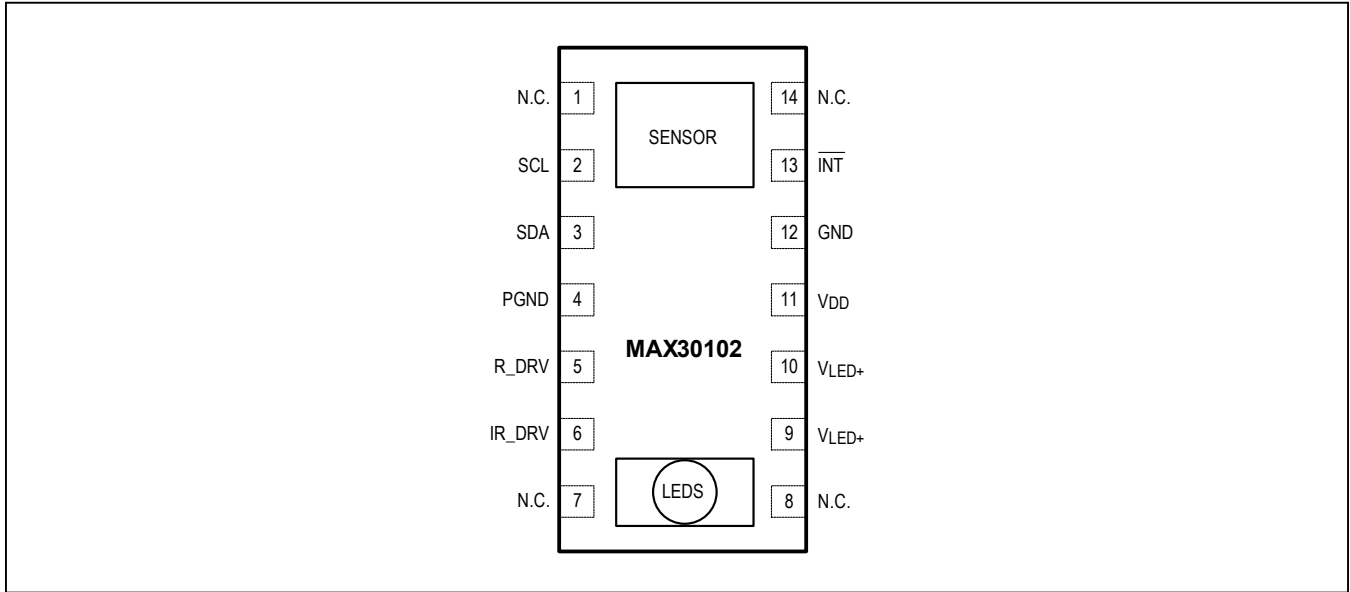

Pin Description

PIN	NAME	FUNCTION
1, 7, 8, 14	N.C.	No Connection. Connect to PCB pad for mechanical stability.
2	SCL	I ² C Clock Input
3	SDA	I ² C Data, Bidirectional (Open-Drain)
4	PGND	Power Ground of the LED Driver Blocks
5	R_DRV	Red LED Driver.
6	IR_DRV	IR LED Driver.
9	V _{LED+}	LED Power Supply (anode connection). Use a bypass capacitor to PGND for best performance.
10	V _{LED+}	
11	V _{DD}	Analog Power Supply Input. Use a bypass capacitor to GND for best performance.
12	GND	Analog Ground
13	INT	Active-Low Interrupt (Open-Drain). Connect to an external voltage with a pullup resistor.

Functional Diagram

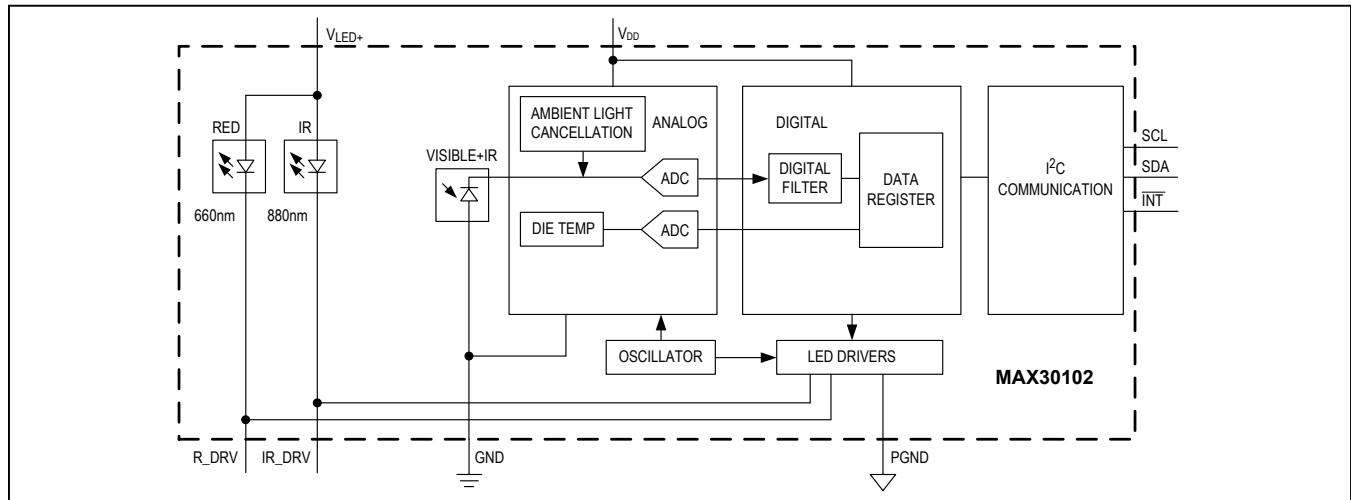

Detailed Description

The MAX30102 is a complete pulse oximetry and heart-rate sensor system solution module designed for the demanding requirements of wearable devices. The device maintains a very small solution size without sacrificing optical or electrical performance. Minimal external hardware components are required for integration into a wearable system.

The MAX30102 is fully adjustable through software registers, and the digital output data can be stored in a 32-deep FIFO within the IC. The FIFO allows the MAX30102 to be connected to a microcontroller or processor on a shared bus, where the data is not being read continuously from the MAX30102's registers.

SpO₂ Subsystem

The SpO₂ subsystem of the MAX30102 contains ambient light cancellation (ALC), a continuous-time sigma-delta ADC, and a proprietary discrete time filter. The ALC has an internal Track/Hold circuit to cancel ambient light and increase the effective dynamic range. The SpO₂ ADC has programmable full-scale ranges from 2µA to 16µA. The ALC can cancel up to 200µA of ambient current.

The internal ADC is a continuous time oversampling sigma-delta converter with 18-bit resolution. The ADC sampling rate is 10.24MHz. The ADC output data rate can be programmed from 50sps (samples per second) to 3200sps. The MAX30102 includes a proprietary discrete time filter to reject 50Hz/60Hz interference and slow-moving residual ambient noise.

Temperature Sensor

The MAX30102 has an on-chip temperature sensor for calibrating the temperature dependence of the SpO₂ subsystem. The temperature sensor has an inherent resolution of 0.0625°C.

The device output data is relatively insensitive to the wavelength of the IR LED, where the Red LED's wavelength is critical to correct interpretation of the data. An SpO₂ algorithm used with the MAX30102 output signal can compensate for the associated SpO₂ error with ambient temperature changes.

LED Driver

The MAX30102 integrates Red and IR LED drivers to modulate LED pulses for SpO₂ and HR measurements. The LED current can be programmed from 0 to 50mA with proper supply voltage. The LED pulse width can be programmed from 69µs to 411µs to allow the algorithm to optimize SpO₂ and HR accuracy and power consumption based on use cases.

Proximity Function

The device includes a proximity function to save power and reduce visible light emission when the user's finger is not on the sensor. When the SpO₂ or HR function is initiated (by writing the MODE register), the IR LED is activated in proximity mode with a drive current set by the PILOT_PA register. When an object is detected by exceeding the IR ADC count threshold (set in the PROX_INT_THRESH register), the part transitions automatically to the normal SpO₂/HR Mode. To reenter proximity mode, the MODE register must be rewritten (even if the value is the same).

The proximity function can be disabled by resetting PROX_INT_EN to 0. In this case, the SpO₂ or HR mode begins immediately.

Register Maps and Descriptions

REGISTER	B7	B6	B5	B4	B3	B2	B1	B0	REG ADDR	POR STATE	R/W
STATUS											
Interrupt Status 1	A_FULL	PPG_RDY	ALC_OVF	PROX_INT				PWR_RDY	0x00	0x00	R
Interrupt Status 2							DIE_TEMP_RDY		0x01	0x00	R
Interrupt Enable 1	A_FULL_EN	PPG_RDY_EN	ALC_OVF_EN	PROX_INT_EN					0x02	0x00	R/W
Interrupt Enable 2							DIE_TEMP_RDY_EN		0x03	0x00	R/W
FIFO											
FIFO Write Pointer				FIFO_WR_PTR[4:0]					0x04	0x00	R/W
Overflow Counter				OVF_COUNTER[4:0]					0x05	0x00	R/W
FIFO Read Pointer				FIFO_RD_PTR[4:0]					0x06	0x00	R/W
FIFO Data Register	FIFO_DATA[7:0]								0x07	0x00	R/W
CONFIGURATION											
FIFO Configuration	SMP_AVE[2:0]			FIFO_ROLL_OVER_EN	FIFO_A_FULL[3:0]				0x08	0x00	R/W
Mode Configuration	SHDN	RESET				MODE[2:0]			0x09	0x00	R/W
SpO ₂ Configuration	0 (Reserved)	SPO2_ADC_RGE [1:0]		SPO2_SR[2:0]			LED_PW[1:0]		0x0A	0x00	R/W
RESERVED									0x0B	0x00	R/W
LED Pulse Amplitude	LED1_PA[7:0]								0x0C	0x00	R/W
	LED2_PA[7:0]								0x0D	0x00	R/W
RESERVED									0x0E	0x00	R/W
RESERVED									0x0F	0x00	R/W
Proximity Mode LED Pulse Amplitude	PILOT_PA[7:0]								0x10	0x00	R/W
Multi-LED Mode Control Registers		SLOT2[2:0]				SLOT1[2:0]			0x11	0x00	R/W
		SLOT4[2:0]				SLOT3[2:0]			0x12	0x00	R/W

Register Maps and Descriptions (continued)

REGISTER	B7	B6	B5	B4	B3	B2	B1	B0	REG ADDR	POR STATE	R/W
RESERVED									0x13–0x17	0xFF	R/W
RESERVED									0x18–0x1E	0x00	R
DIE TEMPERATURE											
Die Temp Integer	TINT[7:0]								0x1F	0x00	R
Die Temp Fraction					TFRAC[3:0]				0x20	0x00	R
Die Temperature Config								TEMP_EN	0x21	0x00	R
RESERVED									0x22–0x2F	0x00	R/W
PROXIMITY FUNCTION											
Proximity Interrupt Threshold	PROX_INT_THRESH[7:0]								0x30	0x00	R/W
PART ID											
Revision ID	REV_ID[7:0]								0xFE	0XX*	R
Part ID	PART_ID[7]								0xFF	0x15	R

*XX denotes a 2-digit hexadecimal number (00 to FF) for part revision identification. Contact Maxim Integrated for the revision ID number assigned for your product.

Interrupt Status (0x00–0x01)

REGISTER	B7	B6	B5	B4	B3	B2	B1	B0	REG ADDR	POR STATE	R/W
Interrupt Status 1	A_FULL	PPG_RDY	ALC_OVF	PROX_INT				PWR_RDY	0x00	0x00	R
Interrupt Status 2							DIE_TEMP_RDY		0x01	0x00	R

Whenever an interrupt is triggered, the MAX30102 pulls the active-low interrupt pin into its low state until the interrupt is cleared.

A_FULL: FIFO Almost Full Flag

In SpO₂ and HR modes, this interrupt triggers when the FIFO write pointer has a certain number of free spaces remaining. The trigger number can be set by the FIFO_A_FULL[3:0] register. The interrupt is cleared by reading the Interrupt Status 1 register (0x00).

PPG_RDY: New FIFO Data Ready

In SpO₂ and HR modes, this interrupt triggers when there is a new sample in the data FIFO. The interrupt is cleared by reading the Interrupt Status 1 register (0x00), or by reading the FIFO_DATA register.

ALC_OVF: Ambient Light Cancellation Overflow

This interrupt triggers when the ambient light cancellation function of the SpO₂/HR photodiode has reached its maximum limit, and therefore, ambient light is affecting the output of the ADC. The interrupt is cleared by reading the Interrupt Status 1 register (0x00).

PROX_INT: Proximity Threshold Triggered

The proximity interrupt is triggered when the proximity threshold is reached, and SpO₂/HR mode has begun. This lets the host processor know to begin running the SpO₂/HR algorithm and collect data. The interrupt is cleared by reading the Interrupt Status 1 register (0x00).

PWR_RDY: Power Ready Flag

On power-up or after a brownout condition, when the supply voltage V_{DD} transitions from below the undervoltage lockout (UVLO) voltage to above the UVLO voltage, a power-ready interrupt is triggered to signal that the module is powered-up and ready to collect data.

DIE_TEMP_RDY: Internal Temperature Ready Flag

When an internal die temperature conversion is finished, this interrupt is triggered so the processor can read the temperature data registers. The interrupt is cleared by reading either the Interrupt Status 2 register (0x01) or the TFRAC register (0x20).

The interrupts are cleared whenever the interrupt status register is read, or when the register that triggered the interrupt is read. For example, if the SpO2 sensor triggers an interrupt due to finishing a conversion, reading either the FIFO data register or the interrupt register clears the interrupt pin (which returns to its normal HIGH state). This also clears all the bits in the interrupt status register to zero.

Interrupt Enable (0x02-0x03)

REGISTER	B7	B6	B5	B4	B3	B2	B1	B0	REG ADDR	POR STATE	R/W
Interrupt Enable 1	A_FULL_EN	PPG_RDY_EN	ALC_OVF_EN	PROX_INT_EN					0x02	0x00	R/W
Interrupt Enable 2							DIE_TEMP_RDY_EN		0x03	0x00	R/W

Each source of hardware interrupt, with the exception of power ready, can be disabled in a software register within the MAX30102 IC. The power-ready interrupt cannot be disabled because the digital state of the module is reset upon a brownout condition (low power supply voltage), and the default condition is that all the interrupts are disabled. Also, it is important for the system to know that a brownout condition has occurred, and the data within the module is reset as a result.

The unused bits should always be set to zero for normal operation.

FIFO (0x04–0x07)

REGISTER	B7	B6	B5	B4	B3	B2	B1	B0	REG ADDR	POR STATE	R/W
FIFO Write Pointer				FIFO_WR_PTR[4:0]					0x04	0x00	R/W
Over Flow Counter				OVF_COUNTER[4:0]					0x05	0x00	R/W
FIFO Read Pointer				FIFO_RD_PTR[4:0]					0x06	0x00	R/W
FIFO Data Register	FIFO_DATA[7:0]								0x07	0x00	R/W

FIFO Write Pointer

The FIFO Write Pointer points to the location where the MAX30102 writes the next sample. This pointer advances for each sample pushed on to the FIFO. It can also be changed through the I²C interface when MODE[2:0] is 010, 011, or 111.

FIFO Overflow Counter

When the FIFO is full, samples are not pushed on to the FIFO, samples are lost. OVF_COUNTER counts the number of samples lost. It saturates at 0xF. When a complete sample is “popped” (i.e., removal of old FIFO data and shifting the samples down) from the FIFO (when the read pointer advances), OVF_COUNTER is reset to zero.

FIFO Read Pointer

The FIFO Read Pointer points to the location from where the processor gets the next sample from the FIFO through the I²C interface. This advances each time a sample is popped from the FIFO. The processor can also write to this pointer after reading the samples to allow rereading samples from the FIFO if there is a data communication error.

FIFO Data Register

The circular FIFO depth is 32 and can hold up to 32 samples of data. The sample size depends on the number of LED channels (a.k.a. channels) configured as active. As each channel signal is stored as a 3-byte data signal, the FIFO width can be 3 bytes or 6 bytes in size.

The FIFO_DATA register in the I²C register map points to the next sample to be read from the FIFO. FIFO_RD_PTR points to this sample. Reading FIFO_DATA register, does not automatically increment the I²C register address. Burst reading this register, reads the same address over and over. Each sample is 3 bytes of data per channel (i.e., 3 bytes for RED, 3 bytes for IR, etc.).

The FIFO registers (0x04–0x07) can all be written and read, but in practice only the FIFO_RD_PTR register should be written to in operation. The others are automatically incremented or filled with data by the MAX30102. When starting a new SpO₂ or heart rate conversion, it is recommended to first clear the FIFO_WR_PTR, OVF_COUNTER, and FIFO_RD_PTR registers to all zeroes (0x00) to ensure the FIFO is empty and in a known state. When reading the MAX30102 registers in one burst-read I²C transaction, the register address pointer typically increments so that the next byte of data sent is from the next register, etc. The exception to this is the FIFO data register, register 0x07. When reading this register, the address pointer does not increment, but the FIFO_RD_PTR does. So the next byte of data sent represents the next byte of data available in the FIFO.

Entering and exiting the proximity mode (when PROX_INT_EN = 1) clears the FIFO by setting the write and read pointers equal to each other.

Reading from the FIFO

Normally, reading registers from the I²C interface autoincrements the register address pointer, so that all the registers can be read in a burst read without an I²C START event. In the MAX30102, this holds true for all registers except for the FIFO_DATA register (register 0x07).

Reading the FIFO_DATA register does not automatically increment the register address. Burst reading this register reads data from the same address over and over. Each sample comprises multiple bytes of data, so multiple bytes should be read from this register (in the same transaction) to get one full sample.

The other exception is 0xFF. Reading more bytes after the 0xFF register does not advance the address pointer back to 0x00, and the data read is not meaningful.

FIFO Data Structure

The data FIFO consists of a 32-sample memory bank that can store IR and Red ADC data. Since each sample consists of two channels of data, there are 6 bytes of data for each sample, and therefore 192 total bytes of data can be stored in the FIFO.

The FIFO data is left-justified as shown in Table 1; in other words, the MSB bit is always in the bit 17 data position regardless of ADC resolution setting. See Table 2 for a visual presentation of the FIFO data structure.

Table 1. FIFO Data is Left-Justified

ADC Resolution	FIFO_DATA[17]	FIFO_DATA[16]	...	FIFO_DATA[12]	FIFO_DATA[11]	FIFO_DATA[10]	FIFO_DATA[9]	FIFO_DATA[8]	FIFO_DATA[7]	FIFO_DATA[6]	FIFO_DATA[5]	FIFO_DATA[4]	FIFO_DATA[3]	FIFO_DATA[2]	FIFO_DATA[1]	FIFO_DATA[0]
18-bit	█	█		█	█	█	█	█	█	█	█	█	█	█	█	█
17-bit	█	█		█	█	█	█	█	█	█	█	█	█	█	█	█
16-bit	█	█		█	█	█	█	█	█	█	█	█	█	█	█	█
15-bit	█	█		█	█	█	█	█	█	█	█	█	█	█	█	█

FIFO Data Contains 3 Bytes per Channel

The FIFO data is left-justified, meaning that the MSB is always in the same location regardless of the ADC resolution setting. FIFO DATA[18] – [23] are not used. Table 2 shows the structure of each triplet of bytes (containing the 18-bit ADC data output of each channel).

Each data sample in SpO₂ mode comprises two data triplets (3 bytes each). To read one sample, requires an I²C read command for each byte. Thus, to read one sample in SpO₂ mode, requires 6 I²C byte reads. The FIFO read pointer is automatically incremented after the first byte of each sample is read.

Write/Read Pointers

Write/Read pointers are used to control the flow of data in the FIFO. The write pointer increments every time a new sample is added to the FIFO. The read pointer is incremented every time a sample is read from the FIFO. To reread a sample from the FIFO, decrement its value by one and read the data register again.

The FIFO write/read pointers should be cleared (back to 0x00) upon entering SpO₂ mode or HR mode, so that there is no old data represented in the FIFO. The pointers are automatically cleared if V_{DD} is power-cycled or V_{DD} drops below its UVLO voltage.

Table 2. FIFO Data (3 Bytes per Channel)

BYTE 1							FIFO_DATA[17]	FIFO_DATA[16]
BYTE 2	FIFO_DATA[15]	FIFO_DATA[14]	FIFO_DATA[13]	FIFO_DATA[12]	FIFO_DATA[11]	FIFO_DATA[10]	FIFO_DATA[9]	FIFO_DATA[8]
BYTE 3	FIFO_DATA[7]	FIFO_DATA[6]	FIFO_DATA[5]	FIFO_DATA[4]	FIFO_DATA[3]	FIFO_DATA[2]	FIFO_DATA[1]	FIFO_DATA[0]

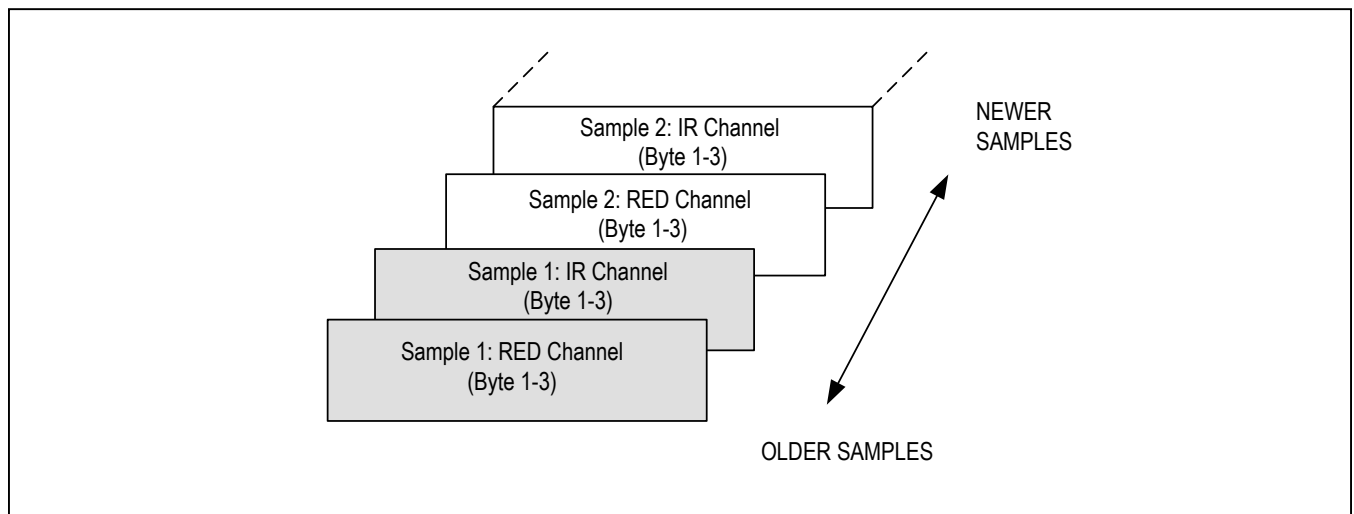

Figure 2. Graphical Representation of the FIFO Data Register. It shows IR and Red in SpO₂ Mode.

Pseudo-Code Example of Reading Data from FIFO

First transaction: Get the FIFO_WR_PTR:

```
START;
Send device address + write mode
Send address of FIFO_WR_PTR;
REPEATED_START;
Send device address + read mode
Read FIFO_WR_PTR;
STOP;
```

The central processor evaluates the number of samples to be read from the FIFO:

```
NUM_AVAILABLE_SAMPLES = FIFO_WR_PTR - FIFO_RD_PTR
(Note: pointer wrap around should be taken into account)
NUM_SAMPLES_TO_READ = < less than or equal to NUM_AVAILABLE_SAMPLES >
```

Second transaction: Read NUM_SAMPLES_TO_READ samples from the FIFO:

```
START;
Send device address + write mode
Send address of FIFO_DATA;
REPEATED_START;
Send device address + read mode
for (i = 0; i < NUM_SAMPLES_TO_READ; i++) {
Read FIFO_DATA;
Save LED1[23:16];
Read FIFO_DATA;
Save LED1[15:8];
Read FIFO_DATA;
Save LED1[7:0];
Read FIFO_DATA;
Save LED2[23:16];
Read FIFO_DATA;
Save LED2[15:8];
Read FIFO_DATA;
Save LED2[7:0];
Read FIFO_DATA;
}
STOP;
START;
Send device address + write mode
Send address of FIFO_RD_PTR;
Write FIFO_RD_PTR;
STOP;
```

Third transaction: Write to FIFO_RD_PTR register. If the second transaction was successful, FIFO_RD_PTR points to the next sample in the FIFO, and this third transaction is not necessary. Otherwise, the processor updates the FIFO_RD_PTR appropriately, so that the samples are reread.

FIFO Configuration (0x08)

REGISTER	B7	B6	B5	B4	B3	B2	B1	B0	REG ADDR	POR STATE	R/W
FIFO Configuration	SMP_AVE[2:0]			FIFO_ROLLOVER_EN	FIFO_A_FULL[3:0]			0x08	0x00	R/W	

Bits 7:5: Sample Averaging (SMP_AVE)

To reduce the amount of data throughput, adjacent samples (in each individual channel) can be averaged and decimated on the chip by setting this register.

Table 3. Sample Averaging

SMP_AVE[2:0]	NO. OF SAMPLES AVERAGED PER FIFO SAMPLE
000	1 (no averaging)
001	2
010	4
011	8
100	16
101	32
110	32
111	32

Bit 4: FIFO Rolls on Full (FIFO_ROLLOVER_EN)

This bit controls the behavior of the FIFO when the FIFO becomes completely filled with data. If FIFO_ROLLOVER_EN is set (1), the FIFO address rolls over to zero and the FIFO continues to fill with new data. If the bit is not set (0), then the FIFO is not updated until FIFO_DATA is read or the WRITE/READ pointer positions are changed.

Bits 3:0: FIFO Almost Full Value (FIFO_A_FULL)

This register sets the number of data samples (3 bytes/sample) remaining in the FIFO when the interrupt is issued. For example, if this field is set to 0x0, the interrupt is issued when there is 0 data samples remaining in the FIFO (all 32 FIFO words have unread data). Furthermore, if this field is set to 0xF, the interrupt is issued when 15 data samples are remaining in the FIFO (17 FIFO data samples have unread data).

FIFO_A_FULL[3:0]	EMPTY DATA SAMPLES IN FIFO WHEN INTERRUPT IS ISSUED	UNREAD DATA SAMPLES IN FIFO WHEN INTERRUPT IS ISSUED
0x0h	0	32
0x1h	1	31
0x2h	2	30
0x3h	3	29
...
0xFh	15	17

Mode Configuration [0x09]

REGISTER	B7	B6	B5	B4	B3	B2	B1	B0	REG ADDR	POR STATE	R/W
Mode Configuration	SHDN	RESET				MODE[2:0]			0x09	0x00	R/W

Bit 7: Shutdown Control (SHDN)

The part can be put into a power-save mode by setting this bit to one. While in power-save mode, all registers retain their values, and write/read operations function as normal. All interrupts are cleared to zero in this mode.

Bit 6: Reset Control (RESET)

When the RESET bit is set to one, all configuration, threshold, and data registers are reset to their power-on-state through a power-on reset. The RESET bit is cleared automatically back to zero after the reset sequence is completed.

Note: Setting the RESET bit does not trigger a PWR_RDY interrupt event.

Bits 2:0: Mode Control

These bits set the operating state of the MAX30102. Changing modes does not change any other setting, nor does it erase any previously stored data inside the data registers.

Table 4. Mode Control

MODE[2:0]	MODE	ACTIVE LED CHANNELS
000	Do not use	
001	Do not use	
010	Heart Rate mode	Red only
011	SpO2 mode	Red and IR
100–110	Do not use	
111	Multi-LED Mode	Red and IR

SpO₂ Configuration (0x0A)

REGISTER	B7	B6	B5	B4	B3	B2	B1	B0	REG ADDR	POR STATE	R/W
SpO ₂ Configuration		SPO2_ADC_RGE[1:0]		SPO2_SR[2:0]			LED_PW[1:0]		0x0A	0x00	R/W

Bits 6:5: SpO₂ ADC Range Control

This register sets the SpO₂ sensor ADC's full-scale range as shown in [Table 5](#).

Table 5. SpO₂ ADC Range Control (18-Bit Resolution)

SPO2_ADC_RGE[1:0]	LSB SIZE (pA)	FULL SCALE (nA)
00	7.81	2048
01	15.63	4096
10	31.25	8192
11	62.5	16384

Bits 4:2: SpO₂ Sample Rate Control

These bits define the effective sampling rate with one sample consisting of one IR pulse/conversion and one Red pulse/conversion.

The sample rate and pulse width are related in that the sample rate sets an upper bound on the pulse width time. If the user selects a sample rate that is too high for the selected LED_PW setting, the highest possible sample rate is programmed instead into the register.

Table 6. SpO₂ Sample Rate Control

SPO2_SR[2:0]	SAMPLES PER SECOND
000	50
001	100
010	200
011	400
100	800
101	1000
110	1600
111	3200

See Table 11 and Table 12 for Pulse Width vs. Sample Rate information.

Bits 1:0: LED Pulse Width Control and ADC Resolution

These bits set the LED pulse width (the IR and Red have the same pulse width), and therefore, indirectly sets the integration time of the ADC in each sample. The ADC resolution is directly related to the integration time.

Table 7. LED Pulse Width Control

LED_PW[1:0]	PULSE WIDTH (μs)	ADC RESOLUTION (bits)
00	69 (68.95)	15
01	118 (117.78)	16
10	215 (215.44)	17
11	411 (410.75)	18

LED Pulse Amplitude (0x0C–0x10)

REGISTER	B7	B6	B5	B4	B3	B2	B1	B0	REG ADDR	POR STATE	R/W
LED Pulse Amplitude	LED1_PA[7:0]								0x0C	0x00	R/W
	LED2_PA[7:0]								0x0D	0x00	R/W
RESERVED									0x0E	0x00	R/W
RESERVED									0x0F	0x00	R/W
Proximity Mode LED Pulse Amplitude	PILOT_PA[7:0]								0x10	0x00	R/W

These bits set the current level of each LED as shown in [Table 8](#).

Table 8. LED Current Control

LEDx_PA [7:0], RED_PA[7:0], or IR_PA[7:0]	TYPICAL LED CURRENT (mA)*
0x00h	0.0
0x01h	0.2
0x02h	0.4
...	...
0x0Fh	3.1
...	...
0x1Fh	6.4
...	...
0x3Fh	12.5
...	...
0x7Fh	25.4
...	...
0xFFh	50.0

*Actual measured LED current for each part can vary widely due to the trimming methodology.

The purpose of PILOT_PA[7:0] is to set the LED power during the proximity mode, as well as in Multi-LED mode.

Multi-LED Mode Control Registers (0x11–0x12)

REGISTER	B7	B6	B5	B4	B3	B2	B1	B0	REG ADDR	POR STATE	R/W
Multi-LED Mode Control Registers		SLOT2[2:0]				SLOT1[2:0]			0x11	0x00	R/W
		SLOT4[2:0]				SLOT3[2:0]			0x12	0x00	R/W

In multi-LED mode, each sample is split into up to four time slots, SLOT1 through SLOT4. These control registers determine which LED is active in each time slot, making for a very flexible configuration.

Table 9. Multi-LED Mode Control Registers

SLOTx[2:0] Setting	WHICH LED IS ACTIVE	LED PULSE AMPLITUDE SETTING
000	None (time slot is disabled)	N/A (Off)
001	LED1 (Red)	LED1_PA[7:0]
010	LED2 (IR)	LED2_PA[7:0]
011	None	N/A (Off)
100	None	N/A (Off)
101	LED1 (Red)	PILOT_PA[7:0]
110	LED2 (IR)	PILOT_PA[7:0]

Each slot generates a 3-byte output into the FIFO. One sample comprises all active slots, for example if SLOT1 and SLOT2 are non-zero, then one sample is 2 x 3 = 6 bytes.

The slots should be enabled in order (i.e., SLOT1 should not be disabled if SLOT2 is enabled).

Temperature Data (0x1F–0x21)

REGISTER	B7	B6	B5	B4	B3	B2	B1	B0	REG ADDR	POR STATE	R/W
Die Temp Integer	TINT[7]								0x1F	0x00	R
Die Temp Fraction					TFRAC[3:0]				0x20	0x00	R
Die Temperature Config								TEMP_EN	0x21	0x00	R

Temperature Integer

The on-board temperature ADC output is split into two registers, one to store the integer temperature and one to store the fraction. Both should be read when reading the temperature data, and the equation below shows how to add the two registers together:

$$T_{\text{MEASURED}} = T_{\text{INTEGER}} + T_{\text{FRACTION}}$$

This register stores the integer temperature data in 2’s complement format, where each bit corresponds to 1°C.

Table 10. Temperature Integer

REGISTER VALUE (hex)	TEMPERATURE (°C)
0x00	0
0x01	+1
...	...
0x7E	+126
0x7F	+127
0x80	-128
0x81	-127
...	...
0xFE	-2
0xFF	-1

Temperature Fraction

This register stores the fractional temperature data in increments of 0.0625°C. If this fractional temperature is paired with a negative integer, it still adds as a positive fractional value (e.g., -128°C + 0.5°C = -127.5°C).

Temperature Enable (TEMP_EN)

This is a self-clearing bit which, when set, initiates a single temperature reading from the temperature sensor. This bit clears automatically back to zero at the conclusion of the temperature reading when the bit is set to one in IR or SpO₂ mode.

Proximity Mode Interrupt Threshold (0x30)

REGISTER	B7	B6	B5	B4	B3	B2	B1	B0	REG ADDR	POR STATE	R/W
Proximity Interrupt Threshold	PROX_INT_THRESHH[7:0]								0x30	0x00	R/W

This register sets the IR ADC count that will trigger the beginning of HR or SpO₂ mode. The threshold is defined as the 8 MSBs bits of the ADC count. For example, if PROX_INT_THRESHH[7:0] = 0x01, then a 17-bit ADC value of 1023 (decimal) or higher triggers the PROX_INT interrupt. If PROX_INT_THRESHH[7:0] = 0xFF, then only a saturated ADC triggers the interrupt.

Applications Information

Sample Rate and Performance

The maximum sample rate for the ADC depends on the selected pulse width, which in turn, determines the ADC resolution. For instance, if the pulse width is set to 69µs then the ADC resolution is 15 bits, and all sample rates are selectable. However, if the pulse width is set to 411µs, then the samples rates are limited. The allowed sample rates for both SpO₂ and HR Modes are summarized in the [Table 11](#) and [Table 12](#).

Power Considerations

The LED waveforms and their implication for power supply design are discussed in this section.

The LEDs in the MAX30102 are pulsed with a low duty cycle for power savings, and the pulsed currents can cause ripples in the V_{LED+} power supply. To ensure these pulses do not translate into optical noise at the LED outputs, the power supply must be designed to handle these. Ensure that the resistance and inductance from the power supply (battery, DC/DC converter, or LDO) to the pin is much smaller than 1Ω, and that there is at least 1µF of power supply bypass capacitance to a good ground plane. The capacitance should be located as close as physically possible to the IC.

Table 11. SpO₂ Mode (Allowed Settings)

SAMPLES PER SECOND	PULSE WIDTH (µs)			
	69	118	215	411
50	○	○	○	○
100	○	○	○	○
200	○	○	○	○
400	○	○	○	○
800	○	○	○	
1000	○	○		
1600	○			
3200				
Resolution (bits)	15	16	17	18

Table 12. HR Mode (Allowed Settings)

SAMPLES PER SECOND	PULSE WIDTH (µs)			
	69	118	215	411
50	○	○	○	○
100	○	○	○	○
200	○	○	○	○
400	○	○	○	○
800	○	○	○	○
1000	○	○	○	○
1600	○	○	○	
3200	○			
Resolution (bits)	15	16	17	18

In the Heart Rate mode, only the Red LED is used to capture optical data and determine the user's heart rate and/or photoplethysmogram (PPG).

SpO₂ Temperature Compensation

The MAX30102 has an accurate on-board temperature sensor that digitizes the IC's internal temperature upon command from the I²C master. The temperature has an effect on the wavelength of the red and IR LEDs. While the device output data is relatively insensitive to the wavelength of the IR LED, the red LED's wavelength is critical to correct interpretation of the data.

Table 13 shows the correlation of red LED wavelength versus the temperature of the LED. Since the LED die heats up with a very short thermal time constant (tens of microseconds), the LED wavelength should be calculated according to the current level of the LED and the temperature of the IC. Use Table 13 to estimate the temperature.

Red LED Current Settings vs. LED Temperature Rise

Add the temperature rise to the module temperature reading to estimate the LED temperature and output wavelength. The LED temperature estimate is valid even with very short pulse widths, due to the fast thermal time constant of the LED.

Interrupt Pin Functionality

The active-low interrupt pin pulls low when an interrupt is triggered. The pin is open-drain, which means it normally requires a pullup resistor or current source to an external voltage supply (up to +5V from GND). The interrupt pin is not designed to sink large currents, so the pullup resistor value should be large, such as 4.7kΩ.

Table 13. RED LED Current Settings vs. LED Temperature Rise

RED LED CURRENT SETTING	RED LED DUTY CYCLE (% OF LED PULSE WIDTH TO SAMPLE TIME)	ESTIMATED TEMPERATURE RISE (ADD TO TEMP SENSOR MEASUREMENT) (°C)
0001 (0.2mA)	8	0.1
1111 (50mA)	8	2
0001 (0.2mA)	16	0.3
1111 (50mA)	16	4
0001 (0.2mA)	32	0.6
1111 (50mA)	32	8

Timing for Measurements and Data Collection

Slot Timing in Multi-LED Modes

The MAX30102 can support two LED channels of sequential processing (Red and IR). Table 14 below displays the four possible channel slot times associated with each pulse width setting. Figure 3 shows an example of channel slot timing for a SpO₂ mode application with a 1kHz sample rate.

Table 14. Slot Timing

PULSE-WIDTH SETTING (μs)	CHANNEL SLOT TIMING (TIMING PERIOD BETWEEN PULSES) (μs)	CHANNEL-CHANNEL TIMING (RISING EDGE-TO-RISING EDGE) (μs)
69	358	427
118	407	525
215	505	720
411	696	1107

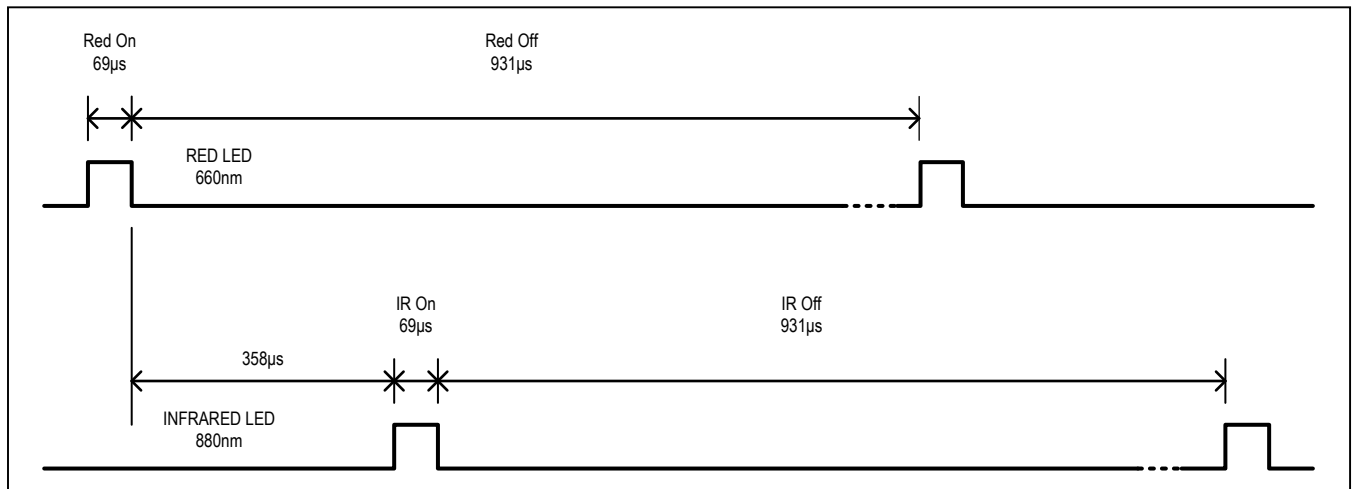

Figure 3. Channel Slot Timing for the SpO₂ Mode with a 1kHz Sample Rate

Timing in SpO₂ Mode

The internal FIFO stores up to 32 samples, so that the system processor does not need to read the data after every sample. Temperature data is needed to properly interpret SpO₂ data (Figure 4), but the temperature does not need to be sampled very often—once a second or every few seconds should be sufficient.

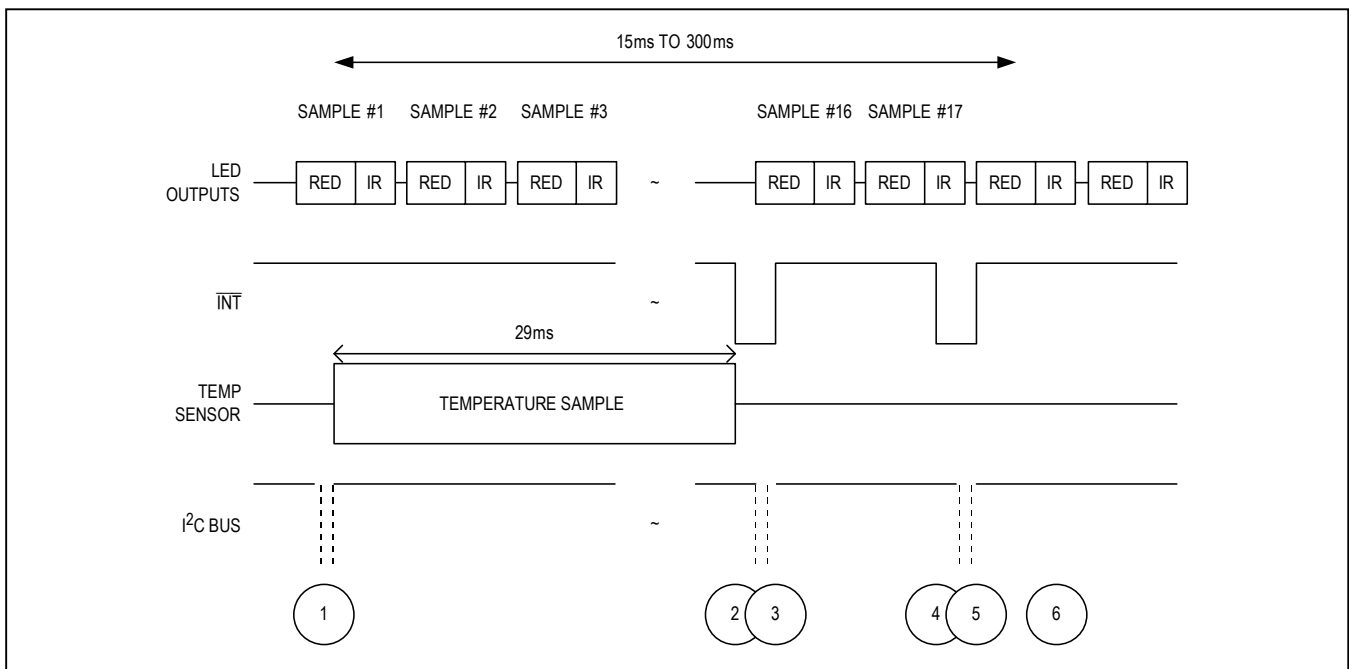

Figure 4. Timing for Data Acquisition and Communication When in SpO₂ Mode

Table 15. Events Sequence for Figure 4 in SpO₂ Mode

EVENT	DESCRIPTION	COMMENTS
1	Enter into SpO ₂ Mode. Initiate a Temperature measurement.	I ² C Write Command sets MODE[2:0] = 0x03. At the same time, set the TEMP_EN bit to initiate a single temperature measurement. Mask the PPG_RDY Interrupt.
2	Temperature Measurement Complete, Interrupt Generated	TEMP_RDY interrupt triggers, alerting the central processor to read the data.
3	Temp Data is Read, Interrupt Cleared	
4	FIFO is Almost Full, Interrupt Generated	Interrupt is generated when the FIFO almost full threshold is reached.
5	FIFO Data is Read, Interrupt Cleared	
6	Next Sample is Stored	New Sample is Stored at the new read pointer location. Effectively, it is now the first sample in the FIFO.

Timing in HR Mode

The internal FIFO stores up to 32 samples, so that the system processor does not need to read the data after every sample. In HR mode (Figure 5), unlike in SpO₂ mode, temperature information is not necessary to interpret the data. The user can select either the red LED or the infrared LED channel for heart rate measurements.

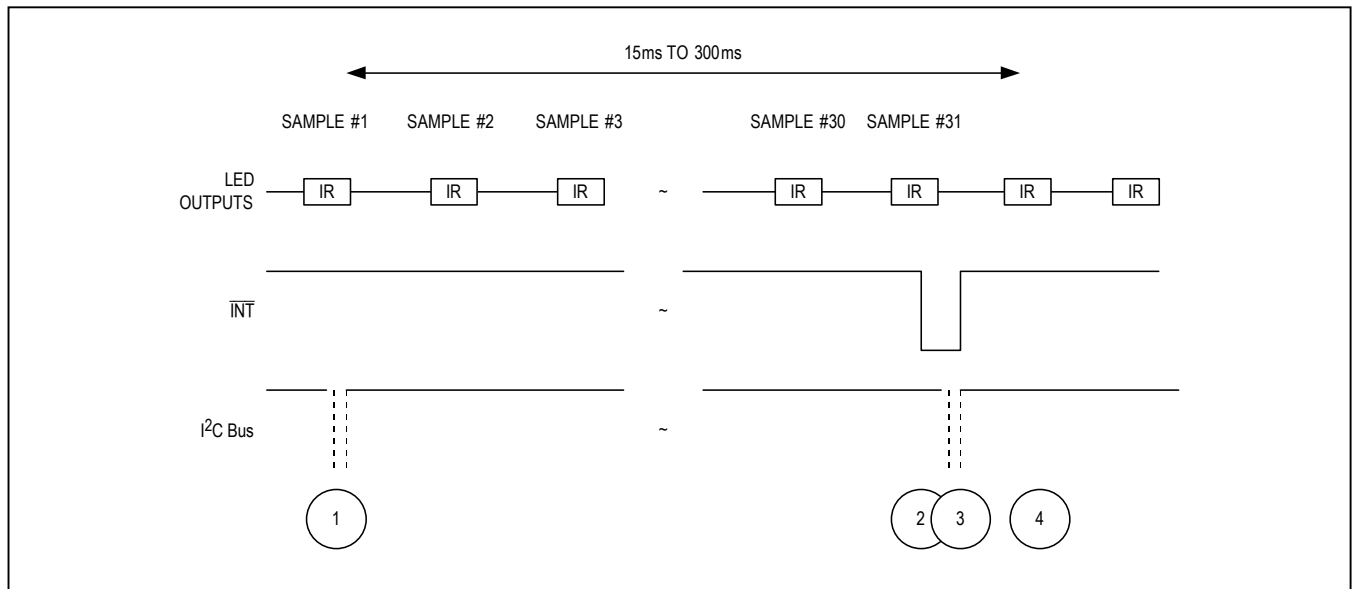

Figure 5. Timing for Data Acquisition and Communication When in HR Mode

Table 16. Events Sequence for Figure 5 in HR Mode

EVENT	DESCRIPTION	COMMENTS
1	Enter into Mode	I ² C Write Command sets MODE[2:0] = 0x02. Mask the PPG_RDY Interrupt.
2	FIFO is Almost Full, Interrupt Generated	Interrupt is generated when the FIFO has only one empty space left.
3	FIFO Data is Read, Interrupt Cleared	
4	Next Sample is Stored	New sample is stored at the new read pointer location. Effectively, it is now the first sample in the FIFO.

Power Sequencing and Requirements

Power-Up Sequencing

Figure 6. shows the recommended power-up sequence for the MAX30102.

It is recommended to power the V_{DD} supply first, before the LED power supplies (R_LED+ , IR_LED+). The interrupt and I²C pins can be pulled up to an external voltage even when the power supplies are not powered up.

After the power is established, an interrupt occurs to alert the system that the MAX30102 is ready for operation. Reading the I²C interrupt register clears the interrupt, as shown in Figure 6.

Power-Down Sequencing

The MAX30102 is designed to be tolerant of any power supply sequencing on power-down.

I²C Interface

The MAX30102 features an I²C/SMBus-compatible, 2-wire serial interface consisting of a serial data line (SDA) and a serial clock line (SCL). SDA and SCL facilitate communication between the MAX30102 and the master at clock rates up to 400kHz. Figure 1 shows the 2-wire interface timing diagram. The master generates SCL and initiates data transfer on the bus. The master device writes data to the MAX30102 by transmitting the proper slave address followed by data. Each transmit sequence is framed by a START (S) or REPEATED START (Sr) condition and a STOP (P) condition. Each word transmitted to the MAX30102 is 8 bits long and is followed by an acknowledge clock pulse. A master reading data from the MAX30102 transmits the proper slave address followed by a series of nine SCL pulses.

The MAX30102 transmits data on SDA in sync with the master-generated SCL pulses. The master acknowledges receipt of each byte of data. Each read sequence is framed by a START (S) or REPEATED START (Sr) condition, a not acknowledge, and a STOP (P) condition. SDA operates as both an input and an open-drain output. A pullup resistor, typically greater than 500 Ω , is required on SDA. SCL operates only as an input. A pullup resistor, typically greater than 500 Ω , is required on SCL if there are multiple masters on the bus, or if the single master has an open-drain SCL output. Series resistors in line with SDA and SCL are optional. Series resistors protect the digital inputs of the MAX30102 from high voltage spikes on the bus lines and minimize crosstalk and undershoot of the bus signals.

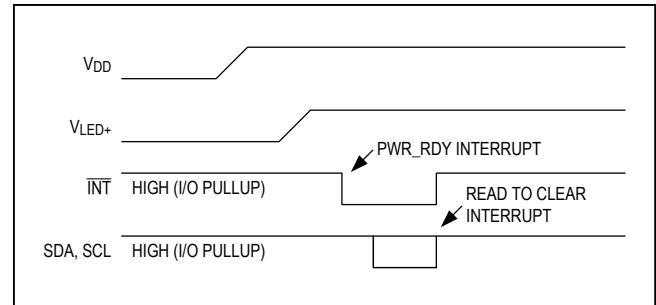

Figure 6. Power-Up Sequence of the Power Supply Rails

Bit Transfer

One data bit is transferred during each SCL cycle. The data on SDA must remain stable during the high period of the SCL pulse. Changes in SDA while SCL is high are control signals. See the [START and STOP Conditions](#) section.

START and STOP Conditions

SDA and SCL idle high when the bus is not in use. A master initiates communication by issuing a START condition. A START condition is a high-to-low transition on SDA with SCL high. A STOP condition is a low-to-high transition on SDA while SCL is high (Figure 7). A START condition from the master signals the beginning of a transmission to the device. The master terminates transmission, and frees the bus, by issuing a STOP condition. The bus remains active if a REPEATED START condition is generated instead of a STOP condition.

Early STOP Conditions

The MAX30102 recognizes a STOP condition at any point during data transmission except if the STOP condition occurs in the same high pulse as a START condition. For proper operation, do not send a STOP condition during the same SCL high pulse as the START condition.

Slave Address

A bus master initiates communication with a slave device by issuing a START condition followed by the 7-bit slave ID. When idle, the MAX30102 waits for a START condition followed by its slave ID. The serial interface compares each slave ID bit by bit, allowing the interface to power down and disconnect from SCL immediately if an incorrect slave ID is detected. After recognizing a START condition followed by the correct slave ID, the MAX30102 is programmed to accept or send data. The LSB of the slave ID word is the read/write (R/W) bit. R/W indicates whether the master is writing to or reading data from the MAX30102 (R/W = 0 selects a write condition, R/W = 1 selects a read condition).

MAX30102

High-Sensitivity Pulse Oximeter and Heart-Rate Sensor for Wearable Health

After receiving the proper slave ID, the MAX30102 issues an ACK by pulling SDA low for one clock cycle.

The MAX30102 slave ID consists of seven fixed bits, B7–B1 (set to 0b1010111). The most significant slave ID bit (B7) is transmitted first, followed by the remaining bits. [Table 17](#) shows the possible slave IDs of the device.

Acknowledge

The acknowledge bit (ACK) is a clocked 9th bit that the MAX30102 uses to handshake receipt each byte of data when in write mode ([Figure 8](#)). The MAX30102 pulls down SDA during the entire master-generated 9th clock pulse if the previous byte is successfully received. Monitoring ACK allows for detection of unsuccessful data transfers. An unsuccessful data transfer occurs if a receiving device is busy or if a system fault has occurred. In the event of an unsuccessful data transfer, the bus master retries communication. The master pulls down SDA

during the 9th clock cycle to acknowledge receipt of data when the MAX30102 is in read mode. An acknowledge is sent by the master after each read byte to allow data transfer to continue. A not-acknowledge is sent when the master reads the final byte of data from the MAX30102, followed by a STOP condition.

Write Data Format

For the write operation, send the slave ID as the first byte followed by the register address byte and then one or more data bytes. The register address pointer increments automatically after each byte of data received, so for example the entire register bank can be written by at one time. Terminate the data transfer with a STOP condition. The write operation is shown in [Figure 9](#).

The internal register address pointer increments automatically, so writing additional data bytes fill the data registers in order.

Table 17. Slave ID Description

B7	B6	B5	B4	B3	B2	B1	B0	WRITE ADDRESS	READ ADDRESS
1	0	1	0	1	1	1	R \bar{W}	0xAE	0xAF

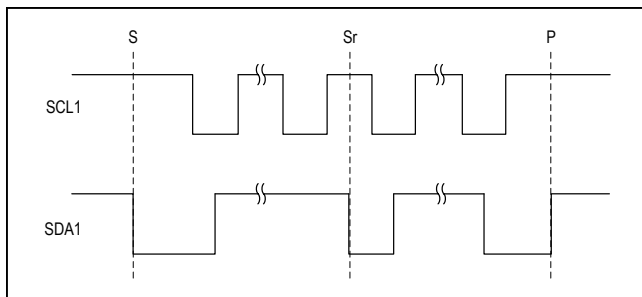

Figure 7. START, STOP, and REPEATED START Conditions

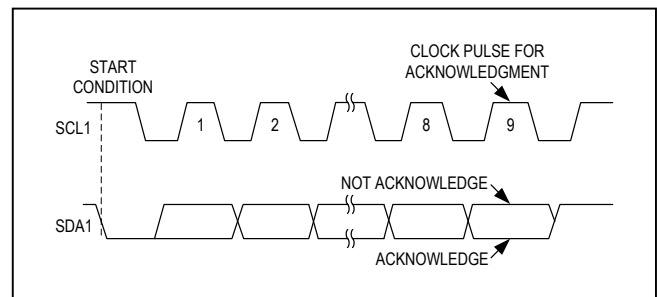

Figure 8. Acknowledge

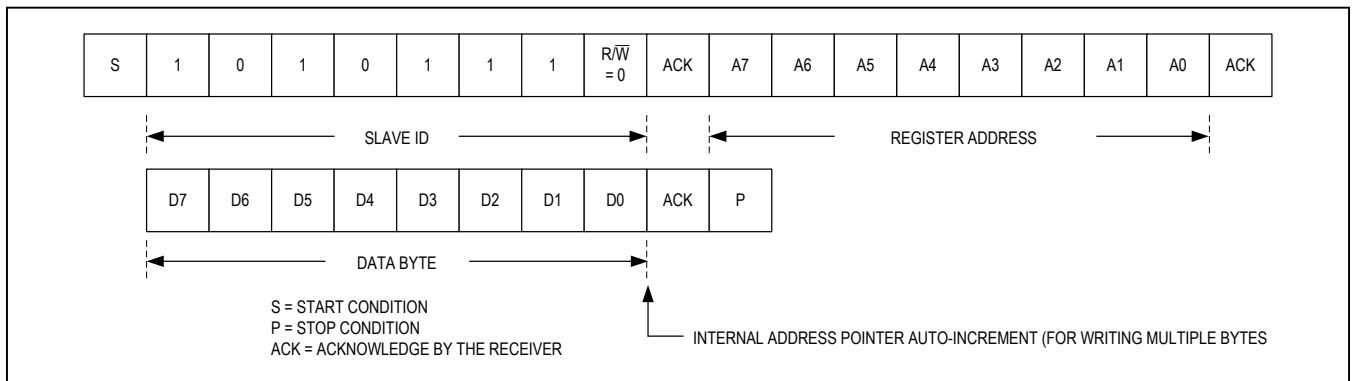

Figure 9. Writing One Data Byte to the MAX30102

Read Data Format

For the read operation, two I²C operations must be performed. First, the slave ID byte is sent followed by the I²C register that you wish to read. Then a REPEAT START (Sr) condition is sent, followed by the read slave ID. The MAX30102 then begins sending data beginning with the register selected in the first operation. The read pointer increments automatically, so the device continues sending data from additional registers in sequential order until a STOP (P) condition is received. The exception to this is the FIFO_DATA register, at which the read pointer no longer increments when reading additional bytes. To

read the next register after FIFO_DATA, an I²C write command is necessary to change the location of the read pointer.

Figure 10 and Figure 11 show the process of reading one byte and multiple bytes of data.

An initial write operation is required to send the read register address.

Data is sent from registers in sequential order, starting from the register selected in the initial I²C write operation. If the FIFO_DATA register is read, the read pointer will not automatically increment, and subsequent bytes of data will contain the contents of the FIFO.

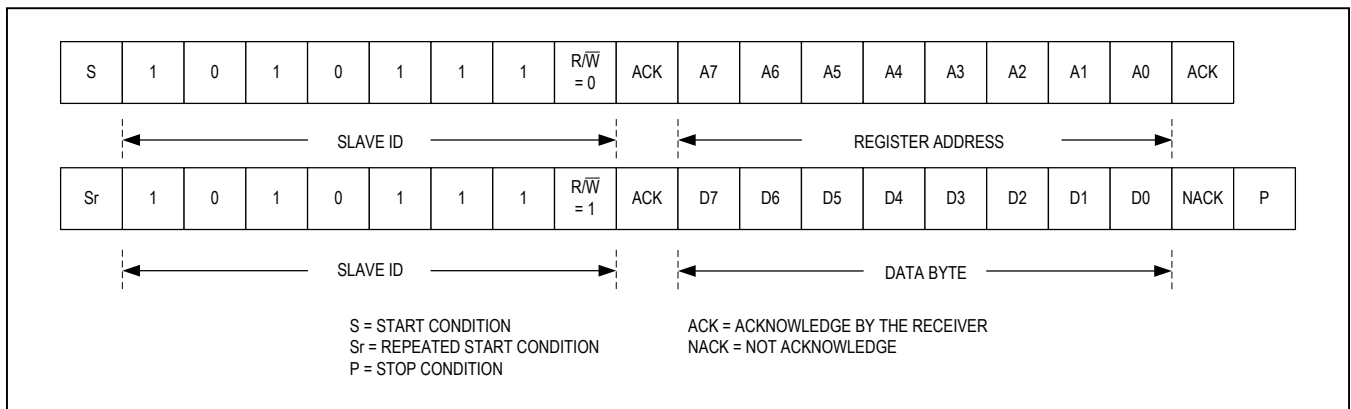

Figure 10. Reading one byte of data from MAX30102

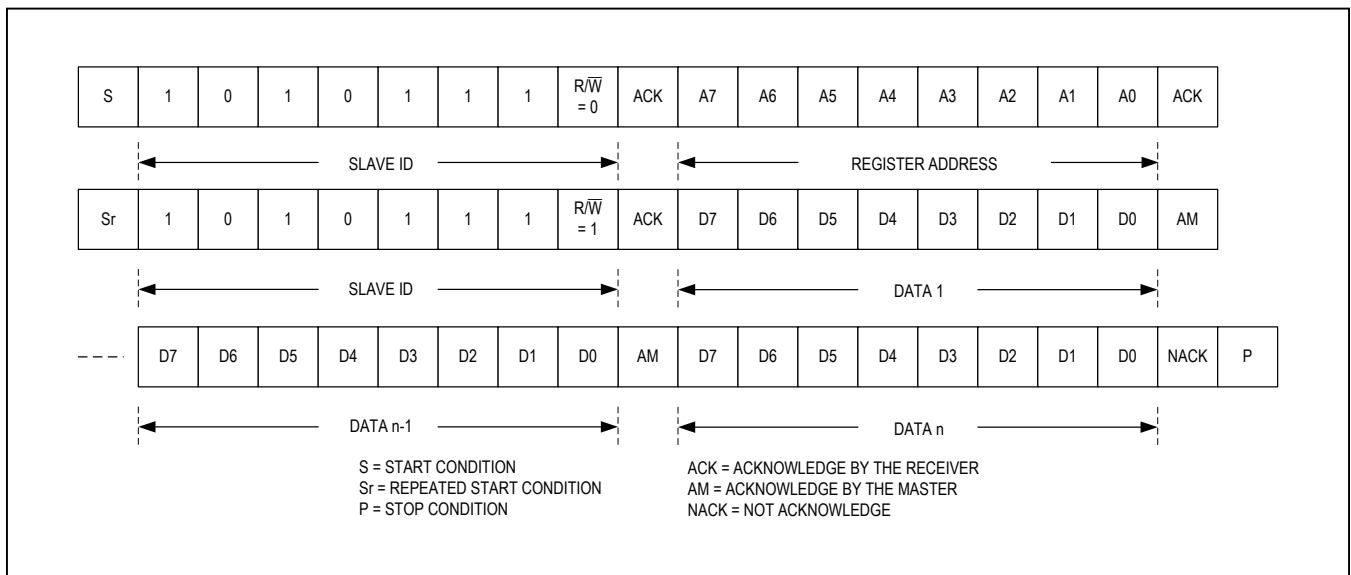
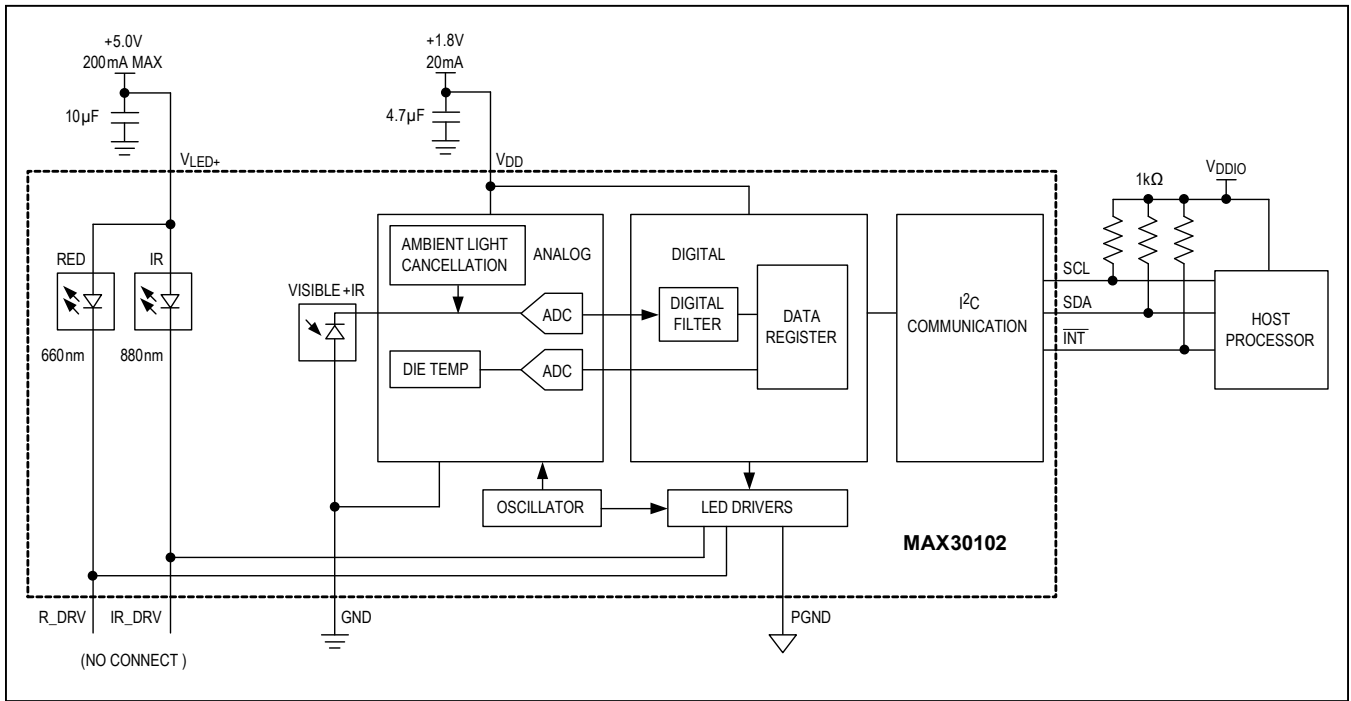

Figure 11. Reading multiple bytes of data from the MAX30102

Typical Application Circuit



Ordering Information

PART	TEMP RANGE	PIN-PACKAGE
MAX30102EFD+T	-40°C to +85°C	14-Lead OESIP (0.8mm Pin Pitch)

+Denotes lead(Pb)-free/RoHS-compliant package.

T = Tape and reel.

Package Information

For the latest package outline information and land patterns (footprints), go to www.maximintegrated.com/packages. Note that a "+", "#", or "-" in the package code indicates RoHS status only. Package drawings may show a different suffix character, but the drawing pertains to the package regardless of RoHS status.

PACKAGE TYPE	PACKAGE CODE	OUTLINE NO.	LAND PATTERN NO.
14 OESIP	F143A5MK+1	21-1048	90-0602

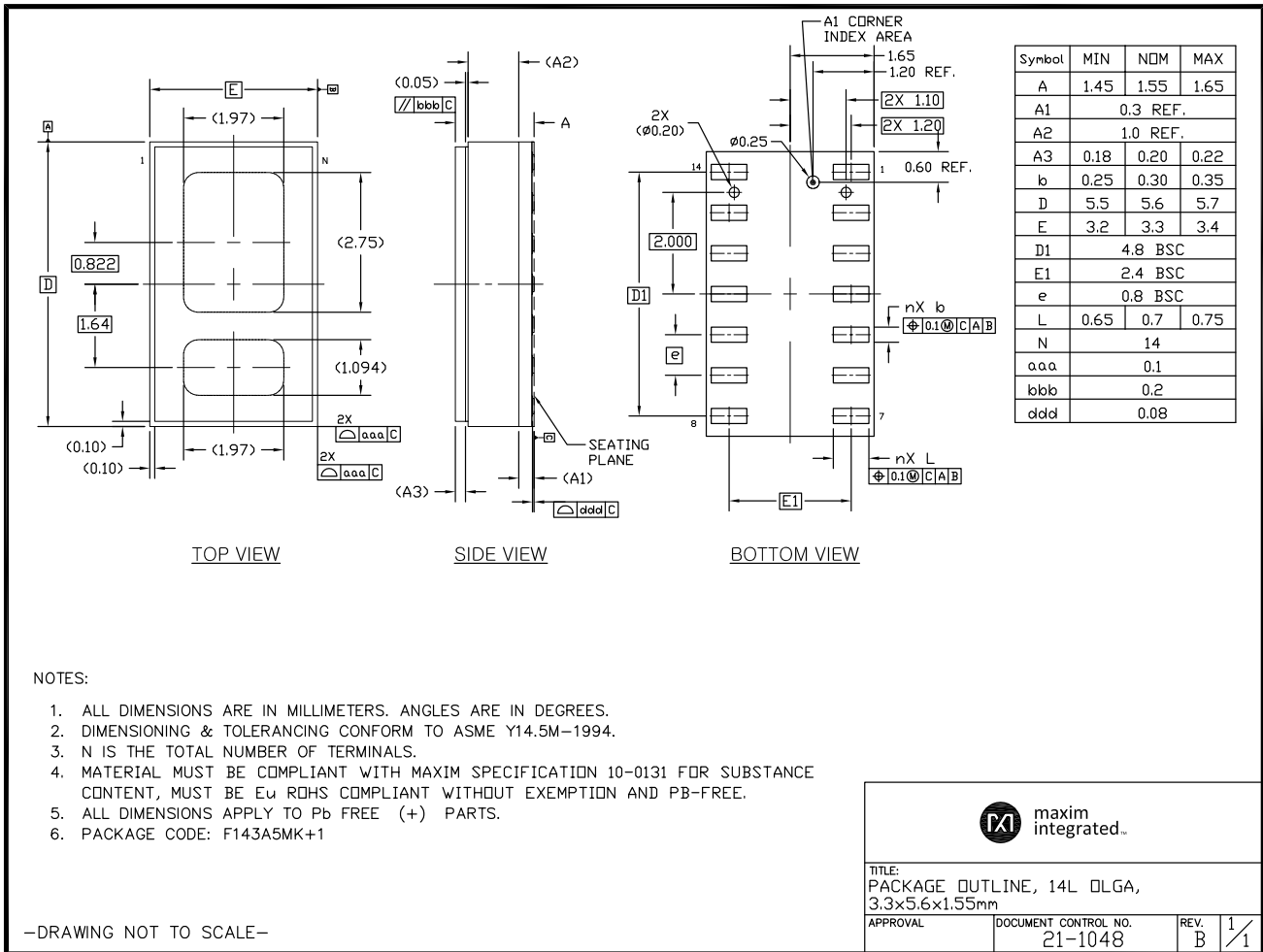

Package Information (continued)

For the latest package outline information and land patterns (footprints), go to www.maximintegrated.com/packages. Note that a "+", "#", or "-" in the package code indicates RoHS status only. Package drawings may show a different suffix character, but the drawing pertains to the package regardless of RoHS status.

NOTES:

1. REFERENCE PKG. OUTLINE: 21-1048
2. LAND PATTERN COMPLIES TO: IPC7351A.
3. TOLERANCE: +/- 0.02 MM.
4. ALL DIMENSIONS APPLY TO PbFREE (+) PKG. CODE ONLY.
5. ALL DIMENSIONS IN MM.

—DRAWING NOT TO SCALE—

TITLE: PACKAGE LAND PATTERN, [F143A5MK+1] QLGA		
APPROVAL	DOCUMENT CONTROL NO. 90-0602	REV. 1 A 1/1

This document (including dimensions, notes & specs) is a recommendation based on typical circuit board manufacturing parameters. Since land pattern design depend on many factors unknown to Maxim (eg. user's board manufacturing specs), user must determine suitability for use. This document is subject to change without notice. Contact technical support at <http://www.maxim-ic.com/support> for further questions.

Revision History

REVISION NUMBER	REVISION DATE	DESCRIPTION	PAGES CHANGED
0	9/15	Initial release	—

For pricing, delivery, and ordering information, please contact Maxim Direct at 1-888-629-4642, or visit Maxim Integrated's website at www.maximintegrated.com.

Maxim Integrated cannot assume responsibility for use of any circuitry other than circuitry entirely embodied in a Maxim Integrated product. No circuit patent licenses are implied. Maxim Integrated reserves the right to change the circuitry and specifications without notice at any time. The parametric values (min and max limits) shown in the Electrical Characteristics table are guaranteed. Other parametric values quoted in this data sheet are provided for guidance.

Компания «Океан Электроники» предлагает заключение долгосрочных отношений при поставках импортных электронных компонентов на взаимовыгодных условиях!

Наши преимущества:

- Поставка оригинальных импортных электронных компонентов напрямую с производств Америки, Европы и Азии, а так же с крупнейших складов мира;
- Широкая линейка поставок активных и пассивных импортных электронных компонентов (более 30 млн. наименований);
- Поставка сложных, дефицитных, либо снятых с производства позиций;
- Оперативные сроки поставки под заказ (от 5 рабочих дней);
- Экспресс доставка в любую точку России;
- Помощь Конструкторского Отдела и консультации квалифицированных инженеров;
- Техническая поддержка проекта, помощь в подборе аналогов, поставка прототипов;
- Поставка электронных компонентов под контролем ВП;
- Система менеджмента качества сертифицирована по Международному стандарту ISO 9001;
- При необходимости вся продукция военного и аэрокосмического назначения проходит испытания и сертификацию в лаборатории (по согласованию с заказчиком);
- Поставка специализированных компонентов военного и аэрокосмического уровня качества (Xilinx, Altera, Analog Devices, Intersil, Interpoint, Microsemi, Actel, Aeroflex, Peregrine, VPT, Syfer, Eurofarad, Texas Instruments, MS Kennedy, Miteq, Cobham, E2V, MA-COM, Hittite, Mini-Circuits, General Dynamics и др.);

Компания «Океан Электроники» является официальным дистрибьютором и эксклюзивным представителем в России одного из крупнейших производителей разъемов военного и аэрокосмического назначения «**JONHON**», а так же официальным дистрибьютором и эксклюзивным представителем в России производителя высокотехнологичных и надежных решений для передачи СВЧ сигналов «**FORSTAR**».



JONHON

«**JONHON**» (основан в 1970 г.)

Разъемы специального, военного и аэрокосмического назначения:

(Применяются в военной, авиационной, аэрокосмической, морской, железнодорожной, горно- и нефтедобывающей отраслях промышленности)

«**FORSTAR**» (основан в 1998 г.)

ВЧ соединители, коаксиальные кабели,
кабельные сборки и микроволновые компоненты:

(Применяются в телекоммуникациях гражданского и специального назначения, в средствах связи, РЛС, а так же военной, авиационной и аэрокосмической отраслях промышленности).



Телефон: 8 (812) 309-75-97 (многоканальный)

Факс: 8 (812) 320-03-32

Электронная почта: ocean@oceanchips.ru

Web: <http://oceanchips.ru/>

Адрес: 198099, г. Санкт-Петербург, ул. Калинина, д. 2, корп. 4, лит. А