

PULSE-WIDTH-MODULATION CONTROL CIRCUITS

AZ7500E

General Description

The AZ7500E is a voltage mode pulse width modulation switching regulator control circuit designed primarily for power supply control.

The AZ7500E consists of a reference voltage circuit, two error amplifiers, an on-chip adjustable oscillator, a dead-time control (DTC) comparator, a pulse-steering control flip-flop, and an output control circuit. The precision of voltage reference (V_{REF}) is improved up to $\pm 1\%$ through trimming and this provides a better output voltage regulation. The AZ7500E provides for push-pull or single-ended output operation, which can be selected through the output control.

AZ7500E is the enhanced version of AZ7500B for it improves REF Pin's reliability comparing with AZ7500B.

The AZ7500E is available in standard packages of DIP-16 and SOIC-16.

Features

- Stable 4.95V Reference Voltage Trimmed to $\pm 1.0\%$ Accuracy
- Uncommitted Output TR for 200mA Sink or Source Current
- Single-End or Push-Pull Operation Selected by Output Control
- Internal Circuitry Prohibits Double Pulse at Either Output
- Complete PWM Control Circuit with Variable Duty Cycle
- On-Chip Oscillator With Master or Slave Operation

Applications

- SMPS
- Back Light Inverter
- Charger

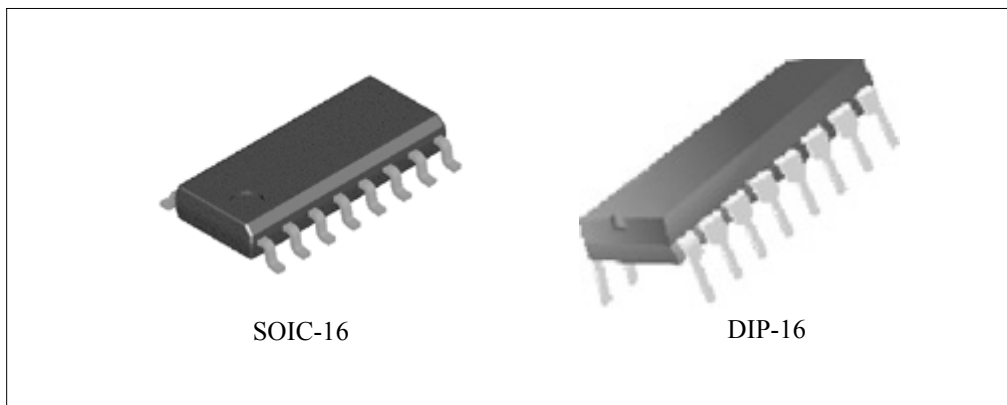

Figure 1. Package Types of AZ7500E

PULSE-WIDTH-MODULATION CONTROL CIRCUITS

AZ7500E

Pin Configuration

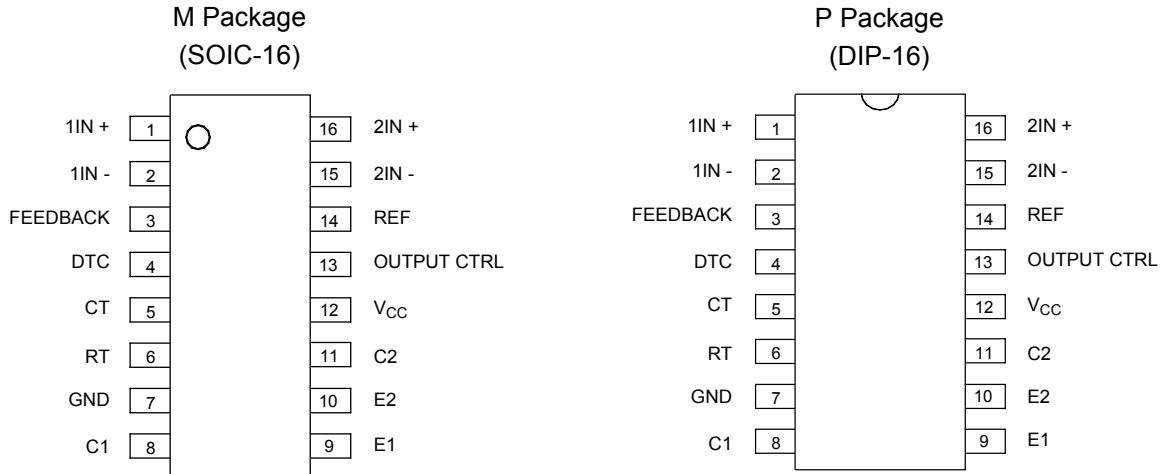

Figure 2. Pin Configuration of AZ7500E (Top View)

Output Function Control Table

Signal for Output Control	Output Function
$V_I = \text{GND}$	Single-ended or parallel output
$V_I = V_{\text{REF}}$	Normal push-pull operation

Functional Block Diagram



Figure 3. Functional Block Diagram of AZ7500E



PULSE-WIDTH-MODULATION CONTROL CIRCUITS

AZ7500E

Ordering Information

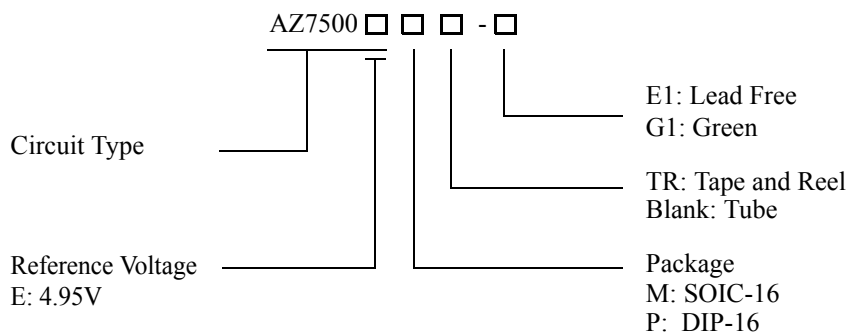

Package	Temperature Range	Part Number		Marking ID		Packing Type
		Lead Free	Green	Lead Free	Green	
SOIC-16	-40 to 85°C	AZ7500EM-E1	AZ7500EM-G1	AZ7500EM-E1	AZ7500EM-G1	Tube
		AZ7500EMTR-E1	AZ7500EMTR-G1	AZ7500EM-E1	AZ7500EM-G1	Tape & Reel
DIP-16		AZ7500EP-E1	AZ7500EP-G1	AZ7500EP-E1	AZ7500EP-G1	Tube

BCD Semiconductor's Pb-free products, as designated with "E1" suffix in the part number, are RoHS compliant. Products with "G1" suffix are available in green packages.

**PULSE-WIDTH-MODULATION CONTROL CIRCUITS****AZ7500E****Absolute Maximum Ratings (Note 1)**

Parameter	Symbol	Value	Unit
Supply Voltage (Note 2)	V_{CC}	40	V
Amplifier Input Voltage	V_I	-0.3 to $V_{CC} + 0.3$	V
Collector Output Voltage	V_O	40	V
Collector Output Current	I_O	250	mA
Package Thermal Impedance (Note 3)	$R_{\theta JA}$	M Package	73
		P Package	67
Lead Temperature 1.6mm from case for 10 seconds		260	°C
Storage Temperature Range	T_{STG}	-65 to 150	°C
ESD rating (Machine Model)		200	V

Note 1: Stresses greater than those listed under "Absolute Maximum Ratings" may cause permanent damage to the device. These are stress ratings only, and functional operation of the device at these or any other conditions beyond those indicated under "Recommended Operating Conditions" is not implied. Exposure to "Absolute Maximum Ratings" for extended periods may affect device reliability.

Note 2: All voltage values are with respect to the network ground terminal.

Note 3: Maximum power dissipation is a function of $T_J(\max)$, $R_{\theta JA}$ and T_A . The maximum allowable power dissipation at any allowable ambient temperature is $P_D = (T_J(\max) - T_A)/R_{\theta JA}$. Operating at the absolute maximum T_J of 150°C can affect reliability.

Recommended Operating Conditions

Parameter	Symbol	Min	Typ	Max	Unit
Supply Voltage	V_{CC}	7	15	36	V
Collector Output Voltage	V_{C1}, V_{C2}		30	36	V
Collector Output Current (Each Transistor)	I_{C1}, I_{C2}			200	mA
Amplifier Input Voltage	V_I	0.3		$V_{CC} - 2$	V
Current Into Feedback Terminal	I_{FB}			0.3	mA
Reference Output Current	I_{REF}			10	mA
Timing Capacitor	C_T	0.00047	0.001	10	μF
Timing Resistor	R_T	1.8	30	500	KΩ
Oscillator Frequency	f_{osc}	1.0	40	200	KHz
PWM Input Voltage (Pin 3, 4, 14)		0.3		5.3	V
Operating Free-Air Temperature	T_A	-40		85	°C



PULSE-WIDTH-MODULATION CONTROL CIRCUITS

AZ7500E

Electrical Characteristics

$T_A = 25^{\circ}\text{C}$, $V_{CC}=20\text{V}$, $f=10\text{KHz}$ unless otherwise noted.

Parameter	Symbol	Conditions	Min	Typ	Max	Unit
Reference Section						
Output Reference Voltage	V_{REF}	$I_{REF}=1\text{mA}$	4.90	4.95	5.0	V
		$I_{REF}=1\text{mA}$, $T_A = -40$ to 85°C	4.85	4.95	5.05	V
Line Regulation	R_{LINE}	$V_{CC} = 7\text{V}$ to 36V		2	25	mV
Load Regulation	R_{LOAD}	$I_{REF}=1\text{mA}$ to 10mA		1	15	mV
Short-Circuit Output Current	I_{SC}	$V_{REF} = 0\text{V}$	10	35	50	mA
Oscillator Section						
Oscillator Frequency	f_{OSC}	$C_T=0.001\mu\text{F}$, $R_T=30\text{K}\Omega$		40		KHz
		$C_T=0.01\mu\text{F}$, $R_T=12\text{K}\Omega$	9.2	10	10.8	
		$C_T=0.01\mu\text{F}$, $R_T=12\text{K}\Omega$, $T_A = -40$ to 85°C	9.0		12	
Frequency Change with Temperature	$\Delta f / \Delta T$	$C_T=0.01\mu\text{F}$, $R_T=12\text{K}\Omega$, $T_A = -40$ to 85°C			1	%
Dead-Time Control Section						
Input Bias Current	I_{BIAS}	$V_{CC}=15\text{V}$, $V_4= 0$ to 5.25V		-2	-10	μA
Maximum Duty Cycle	$D(\text{MAX})$	$V_{CC}=15\text{V}$, $V_4= 0\text{V}$, $\text{Pin } 13= V_{REF}$	45			%
Input Threshold Voltage	V_{ITH}	Zero Duty Cycle		3	3.3	V
		Maximum Duty Cycle	0			
Error-Amplifier Section						
Input Offset Voltage	V_{IO}	$V_3 = 2.5\text{V}$		2	10	mV
Input Offset Current	I_{IO}	$V_3 = 2.5\text{V}$		25	250	nA
Input Bias Current	I_{BIAS}	$V_3 = 2.5\text{V}$		0.2	1	μA
Common-Mode Input Voltage Range	V_{CM}	$V_{CC}=7\text{V}$ to 36V	-0.3		$V_{CC}-2$	V
Open-Loop Voltage Gain	G_{VO}	$V_O = 0.5\text{V}$ to 3.5V	70	95		dB
Unity-Gain Bandwidth	BW			650		KHz
Common-Mode Rejection Ratio	CMRR		65	80		dB
Output Sink Current (Feedback)	I_{SINK}	$V_{ID} = -15\text{mV}$ to -5V , $V_3 = 0.7\text{V}$	-0.3	-0.7		mA
Output Source Current (Feedback)	I_{SOURCE}	$V_{ID}=15\text{mV}$ to 5V $V_3 = 3.5\text{V}$	2			mA

**PULSE-WIDTH-MODULATION CONTROL CIRCUITS****AZ7500E****Electrical Characteristics (Continued)**

Parameter	Symbol	Conditions	Min	Typ	Max	Unit
PWM Comparator Section						
Input Threshold Voltage	V_{ITH}	Zero duty cycle		4	4.5	V
Input Sink Current	I_{SINK}	$V_3 = 0.7V$	-0.3	-0.7		mA
Output Section						
Output Saturation Voltage	Common Emitter	$V_{CE(SAT)}$ $V_E = 0V, I_C = 200mA$		1.1	1.3	V
	Emitter Follower	$V_{CC(SAT)}$ $V_{CC} = 15V, I_E = -200mA$		1.5	2.5	
Collector Off-State Current	$I_C(OFF)$	$V_{CE} = 36V, V_{CC} = 36V$		2	100	μA
Emitter Off-State Current	$I_E(OFF)$	$V_{CC} = V_C = 36V, V_E = 0$			-100	μA
Total Device						
Supply Current	I_{CC}	Pin 6 = V_{REF} , $V_{CC} = 15V$		6	10	mA
Output Switching Characteristics						
Rise Time	t_R	Common Emitter Common Collector		100	200	ns
Fall Time	t_F	Common Emitter Common Collector		25	100	ns

Parameter Measurement information



Figure 4. Operational Test Circuit and Waveforms

Parameter Measurement information (Continued)



Figure 5. Error Amplifier Characteristics



Note A: C_L includes probe and jig capacitance.

Figure 6. Common-Emitter Configuration



Note A: C_L includes probe and jig capacitance.

Figure 7. Emitter-Follower Configuration



Typical Performance Characteristics

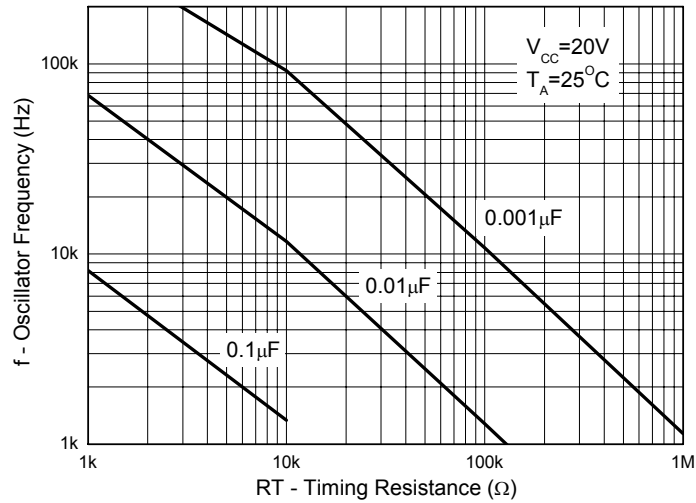

Figure 8. Oscillator Frequency vs. RT and CT

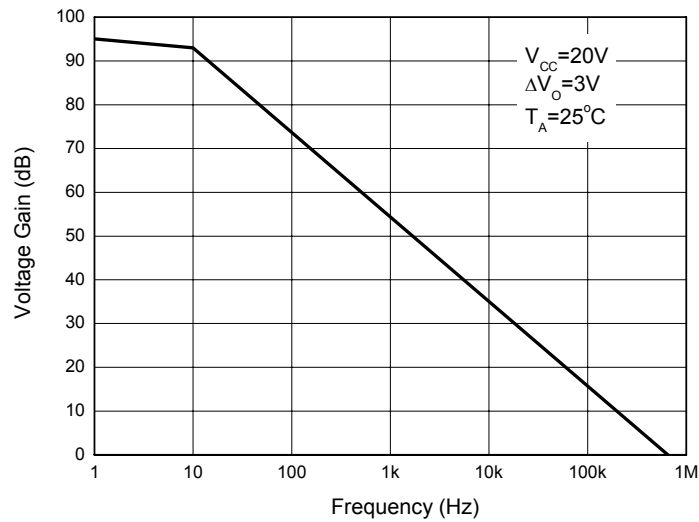

Figure 9. Error Amplifier Small-Signal Voltage Gain vs. Frequency

Typical Applications

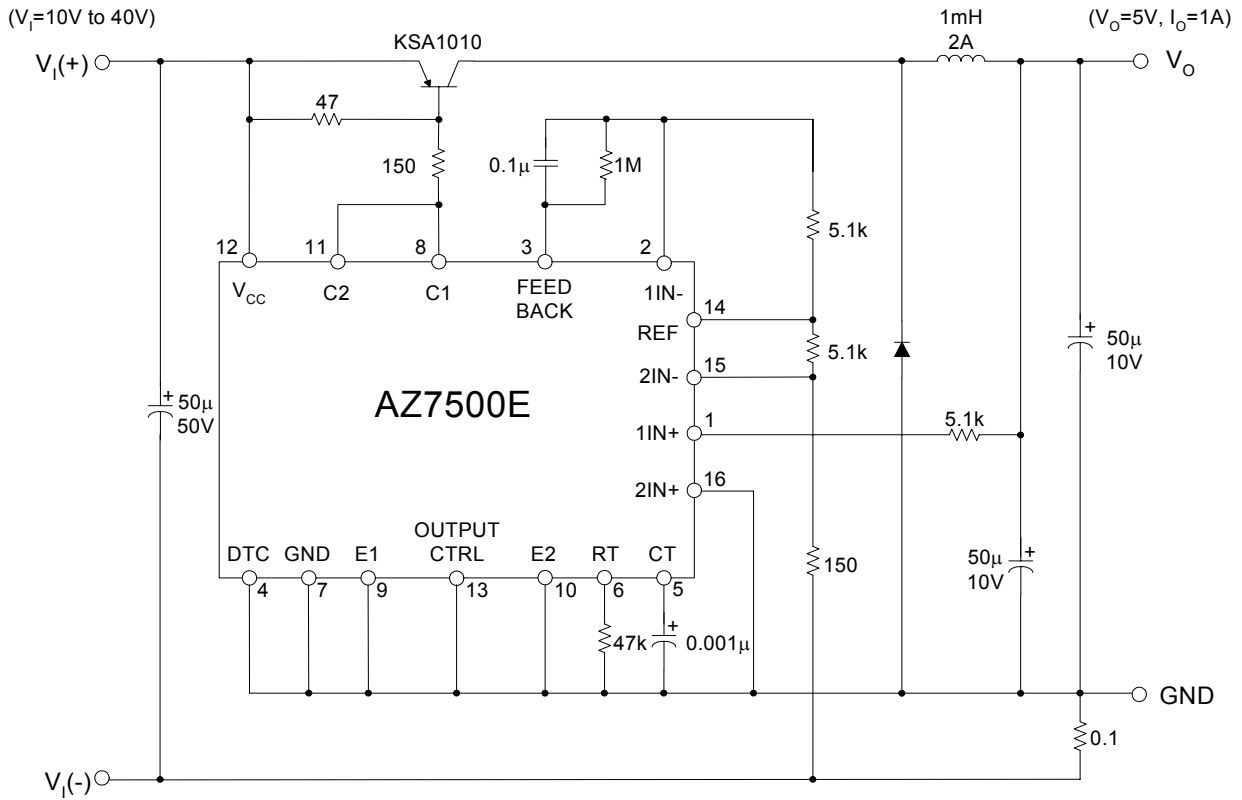

Figure 10. Pulse Width Modulated Step-Down Converter

Mechanical Dimensions

SOIC-16

Unit: mm(inch)



Note: Eject hole, oriented hole and mold mark is optional.



Mechanical Dimensions (Continued)

DIP-16

Unit: mm(inch)

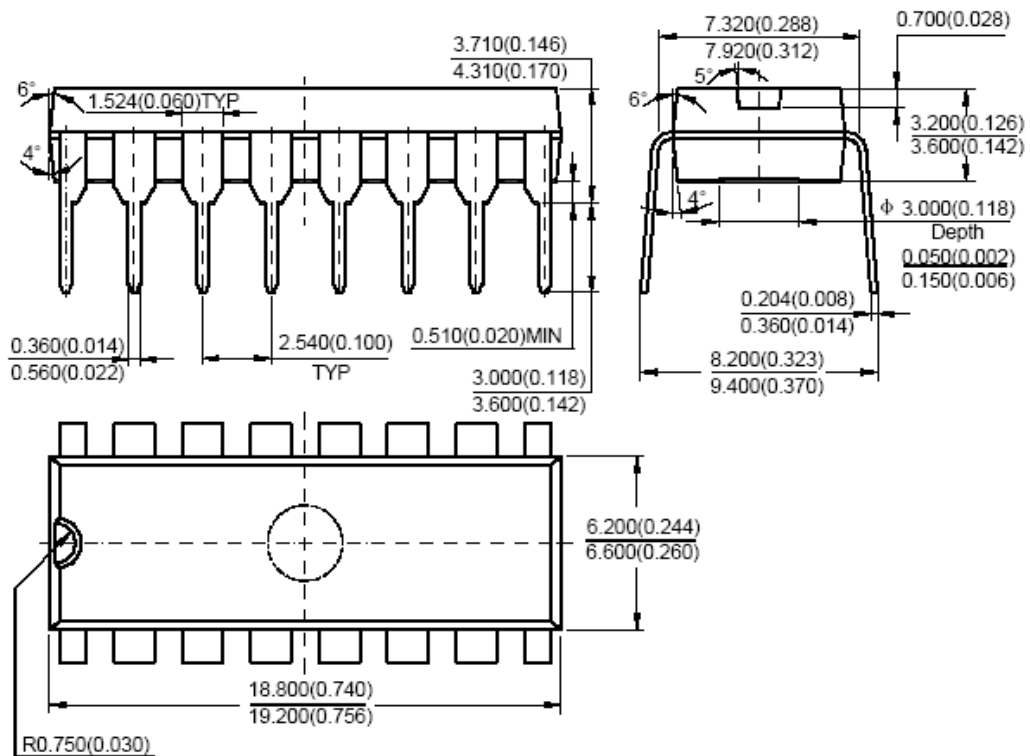

Note: Eject hole, oriented hole and mold mark is optional.



BCD Semiconductor Manufacturing Limited

<http://www.bcdsemi.com>

IMPORTANT NOTICE

BCD Semiconductor Manufacturing Limited reserves the right to make changes without further notice to any products or specifications herein. BCD Semiconductor Manufacturing Limited does not assume any responsibility for use of any its products for any particular purpose, nor does BCD Semiconductor Manufacturing Limited assume any liability arising out of the application or use of any its products or circuits. BCD Semiconductor Manufacturing Limited does not convey any license under its patent rights or other rights nor the rights of others.

MAIN SITE

- Headquarters

BCD Semiconductor Manufacturing Limited

No. 1600, Zi Xing Road, Shanghai ZiZhu Science-based Industrial Park, 200241, China
Tel: +86-21-24162266, Fax: +86-21-24162277

- Wafer Fab

Shanghai SIM-BCD Semiconductor Manufacturing Co., Ltd.

800 Yi Shan Road, Shanghai 200233, China
Tel: +86-21-6485 1491, Fax: +86-21-5450 0008

REGIONAL SALES OFFICE

Shenzhen Office

Shanghai SIM-BCD Semiconductor Manufacturing Co., Ltd., Shenzhen Office

Unit A Room 1203, Skyworth Bldg., Gaoxin Ave. 1.S., Nanshan District, Shenzhen, China
Tel: +86-755-8826 7951
Fax: +86-755-8826 7865

Taiwan Office

BCD Semiconductor (Taiwan) Company Limited

4F, 298-1, Rui Guang Road, Nei-Hu District, Taipei, Taiwan
Tel: +886-2-2656 2808
Fax: +886-2-2656 2806

USA Office

BCD Semiconductor Corp.

30920 Huntwood Ave. Hayward, CA 94544, USA
Tel : +1-510-324-2988
Fax: +1-510-324-2788

Компания «Океан Электроники» предлагает заключение долгосрочных отношений при поставках импортных электронных компонентов на взаимовыгодных условиях!

Наши преимущества:

- Поставка оригинальных импортных электронных компонентов напрямую с производств Америки, Европы и Азии, а так же с крупнейших складов мира;
- Широкая линейка поставок активных и пассивных импортных электронных компонентов (более 30 млн. наименований);
- Поставка сложных, дефицитных, либо снятых с производства позиций;
- Оперативные сроки поставки под заказ (от 5 рабочих дней);
- Экспресс доставка в любую точку России;
- Помощь Конструкторского Отдела и консультации квалифицированных инженеров;
- Техническая поддержка проекта, помощь в подборе аналогов, поставка прототипов;
- Поставка электронных компонентов под контролем ВП;
- Система менеджмента качества сертифицирована по Международному стандарту ISO 9001;
- При необходимости вся продукция военного и аэрокосмического назначения проходит испытания и сертификацию в лаборатории (по согласованию с заказчиком);
- Поставка специализированных компонентов военного и аэрокосмического уровня качества (Xilinx, Altera, Analog Devices, Intersil, Interpoint, Microsemi, Actel, Aeroflex, Peregrine, VPT, Syfer, Eurofarad, Texas Instruments, MS Kennedy, Miteq, Cobham, E2V, MA-COM, Hittite, Mini-Circuits, General Dynamics и др.);

Компания «Океан Электроники» является официальным дистрибьютором и эксклюзивным представителем в России одного из крупнейших производителей разъемов военного и аэрокосмического назначения «**JONHON**», а так же официальным дистрибьютором и эксклюзивным представителем в России производителя высокотехнологичных и надежных решений для передачи СВЧ сигналов «**FORSTAR**».



JONHON

«**JONHON**» (основан в 1970 г.)

Разъемы специального, военного и аэрокосмического назначения:

(Применяются в военной, авиационной, аэрокосмической, морской, железнодорожной, горно- и нефтедобывающей отраслях промышленности)

«**FORSTAR**» (основан в 1998 г.)

ВЧ соединители, коаксиальные кабели,
кабельные сборки и микроволновые компоненты:

(Применяются в телекоммуникациях гражданского и специального назначения, в средствах связи, РЛС, а так же военной, авиационной и аэрокосмической отраслях промышленности).



Телефон: 8 (812) 309-75-97 (многоканальный)

Факс: 8 (812) 320-03-32

Электронная почта: ocean@oceanchips.ru

Web: <http://oceanchips.ru/>

Адрес: 198099, г. Санкт-Петербург, ул. Калинина, д. 2, корп. 4, лит. А