

ZX1

A CMOS Laser Sensor That's Optimum for Simple Measurements



- A resolution of 0.002 mm that's suitable for simple measurements.
- Stable measurements for any type of workpiece.
- Models available with four different distance specifications.
- Long-distance model for up to 1,000 mm.

Refer to **Safety Precautions** on page 4.

This datasheet contains information only for selecting the appropriate model. Be sure to read the instruction sheet for usage precautions prior to using the product.



Ordering Information

Sensors (Refer to Dimensions on page 5.)

Appearance	Connection method	Cable length	Sensing distance	Model	
				NPN output	PNP output
	Pre-wired	2 m		ZX1-LD50A61 2M *	ZX1-LD50A81 2M *
		5 m		ZX1-LD50A61 5M	ZX1-LD50A81 5M
	Pre-wired connector	0.5 m		ZX1-LD50A66 0.5M	ZX1-LD50A86 0.5M
		2 m		ZX1-LD100A61 2M *	ZX1-LD100A81 2M *
	Pre-wired	2 m		ZX1-LD100A61 5M	ZX1-LD100A81 5M
		5 m		ZX1-LD100A66 0.5M	ZX1-LD100A86 0.5M
	Pre-wired connector	0.5 m		ZX1-LD300A61 2M *	ZX1-LD300A81 2M *
		2 m		ZX1-LD300A61 5M	ZX1-LD300A81 5M
	Pre-wired	2 m		ZX1-LD300A66 0.5M	ZX1-LD300A86 0.5M
		5 m		ZX1-LD600A61 2M *	ZX1-LD600A81 2M *
	Pre-wired connector	0.5 m		ZX1-LD600A61 5M	ZX1-LD600A81 5M
		2 m		ZX1-LD600A66 0.5M	ZX1-LD600A86 0.5M

* Sensors with Class 1 lasers are also available. Add an "L" to the end of the model number when ordering. (Example: ZX1-LD50A61L 2M)

Accessories (sold separately)

Extension Cables for Pre-wired Connector Models An Extension Cable is not provided with the Sensor. Order an Extension Cable separately. (Refer to Dimensions on page 6.)

Cable length	Model
10 m	ZX0-XC10R
20 m	ZX0-XC20R

Mounting Brackets A Mounting Bracket is not provided with the Sensor. Order a Mounting Bracket separately if required. (Refer to Dimensions on page 6.)

Applicable sensors	Appearance	Model	Remarks
ZX1-LD50□ ZX1-LD100□		E39-L180	Mounting Bracket: 1 Nut plate: 1 Phillips screws (M3×30): 2
ZX1-LD300□ ZX1-LD600□		E39-L181	Mounting Bracket: 1 Nut plate: 1 Phillips screws (M4×35): 2

ZX1

Ratings and Specifications

Item	Model	NPN output	ZX1-LD50A61 ZX1-LD50A66	ZX1-LD100A61 ZX1-LD100A66	ZX1-LD300A61 ZX1-LD300A66	ZX1-LD600A61 ZX1-LD600A66
		PNP output	ZX1-LD50A81 ZX1-LD50A86	ZX1-LD100A81 ZX1-LD100A86	ZX1-LD300A81 ZX1-LD300A86	ZX1-LD600A81 ZX1-LD600A86
Measurement range			50 ± 10 mm	100 ± 35 mm	300 ± 150 mm	600 ± 400 mm
Light source (wave length)		Visible-light semiconductor laser (wavelength: 660 nm, 1 mW max., IEC/EN Class 2, FDA Class 2 *1)				
Spot diameter (typical) (Defined at the measurement center distance) *2			0.17 mm dia.	0.33 mm dia.	0.52 mm dia.	0.56 mm dia.
Power consumption		2,500 mW max. (105 mA max. at 24 VDC, 210 mA max. at 12 VDC)				
Current consumption		250 mA max. (at power supply voltage 10 VDC)				
Control output		Load power supply voltage: 30 VDC max., Load current: 100 mA max. (Residual voltage: 1 V max. (load current 10 mA or less), 2 V max. (load current of 10 to 100 mA))				
Analog output		Current output: 4 to 20 mA, maximum load resistance: 300 Ω (The output is 20 mA for the nearest point in the measurement range in respect to the Sensor and 4 mA for the farthest point.)				
Functions		Smart tuning, keep function, background removal, OFF-delay timer, ON-delay timer, one-shot timer, ON/OFF-delay timer, zero reset, area output, eco function, hysteresis width setting, and setting initialization				
Indicators		Digital display (red), output indicator (OUT1, OUT2) (orange), zero reset indicator (orange), menu indicator (orange), laser ON indicator (green), and smart tuning indicator (blue)				
Response time	Judgment output	Super-high-speed (SHS) Mode: 1 ms High-speed (HS) Mode: 10 ms Standard (Stnd) Mode : 100 ms				
	Laser OFF input	200 ms max.				
	Zero reset input	200 ms max.				
Temperature characteristic *3		0.03% F.S./°C				0.04% F.S./°C
Linearity *4		±0.15% F.S.			±0.25% F.S.	±0.25% F.S. (200 to 600 mm) ±0.5% F.S. (entire range)
Resolution *5		2 μm	7 μm	30 μm	80 μm	
Ambient illumination		Illumination on received light surface: 7,500 lx or less (incandescent light)			Illumination on received light surface: 5,000 lx or less (incandescent light)	
Ambient temperature		Operating: -10 to +55°C, Storage: -15 to +70°C (with no icing or condensation)				
Ambient humidity		Operating and storage: 35% to 85% (with no condensation)				
Dielectric strength		1,000 VAC, 50/60 Hz, 1 minute				
Vibration resistance (destruction)		10 to 55 Hz, 1.5-mm double amplitude, 2 hours each in X, Y, and Z directions				
Shock resistance (destruction)		500 m/s ² 3 times each in X, Y, and Z directions				
Degree of protection *6		IEC 60529, IP67				
Connection method *7		Pre-wired model (Standard cable length: 2 m, 5 m) Pre-wired connector model (Standard cable length: 0.5 m)				
Weight (packed state/ sensor only)	Pre-wired models (2 m)	Approx. 240 g / Approx. 180 g			Approx. 270 g / Approx. 210 g	
	Pre-wired models (5 m)	Approx. 450 g / Approx. 330 g			Approx. 480 g / Approx. 360 g	
	Pre-wired connector models (0.5 m)	Approx. 170 g / Approx. 110 g			Approx. 200 g / Approx. 140 g	
Materials		Case and cover: PBT (polybutylene terephthalate), Optical window: Glass, Cable: PVC, Mounting hole part: SUS303				
Accessories		Instruction sheet and Laser warning label (English)				

Note: 1. False detection outside the measurement range can occur in the case of an object with high reflectance.

2. Refer to the next page for the ratings and specifications of Sensors with Class 1 lasers.

*1. Classified as Class 2 by IEC60825-1 criteria in accordance with the FDA standard provisions of Laser Notice No. 50. CDRH registration has been completed. (Center for Devices and Radiological Health) (Accession Number: 1210041)

*2. Spot diameter: Defined as 1/e² (13.5%) of the central intensity at the measurement center distance.

False detections can occur in the case there is light leakage outside the defined region and the surroundings of the target object have a high reflectance in comparison to the target object.

Accurate measurements may not be possible for workpieces that are smaller than the spot diameter.

*3. Temperature characteristic: Value for the case the space between the sensor and Omron's standard target object is secured by an aluminum jig. (Measured at the measurement center distance)

*4. Linearity: Indicates the error with respect to the ideal straight line of the displacement output in the case of measuring Omron's standard target object (white ceramic) at a temperature of 25 °C.

Linearity and measured value may vary depending on target object.

*5. Resolution: Defined in Standard Mode for Omron's standard target object (white ceramic) after executing Smart Tuning.

The resolution indicates the repetition accuracy for a still workpiece. Not an indication of the distance accuracy.

Resolution performance may not be satisfied in a strong electromagnetic field.

*6. IP67 protection applies to the connector on pre-wired connector models if an extension cable is connected.

*7. Use a Pre-wired Connector Model together with an Extension Cable (10 m or 20 m).

Ratings and Specifications of Sensors with Class 1 lasers (ZX1-LD□□L)

The ratings and specifications that are different from those of the Sensors with Class 2 lasers are given below.

Item	Model	ZX1-LD50A61L/ZX1-LD50A81L ZX1-LD100A61L/ZX1-LD100A81L	ZX1-LD300A61L/ZX1-LD300A81L ZX1-LD600A61L/ZX1-LD600A81L
FDA Class		Class1 0.24mW max.	
IEC/EN Class		Class1 0.24mW max.	
Ambient illumination		Illumination on received light surface 5,000 lx or less (incandescent light)	Illumination on received light surface 2,500 lx or less (incandescent light)
Connection method		Pre-wired model (2 m)	
Accessories		Instruction sheet and Explanatory label (English), FDA certification label	

Accession Number: 1210041

Engineering Data (Typical)

Angle Characteristic

ZX1-LD50□

Side-to-side Inclination

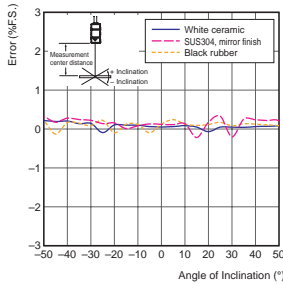

ZX1-LD100□

Side-to-side Inclination

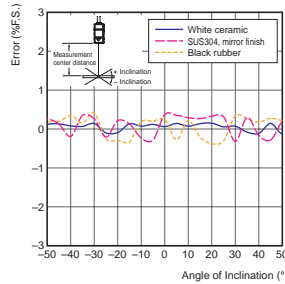

ZX1-LD300□

Side-to-side Inclination

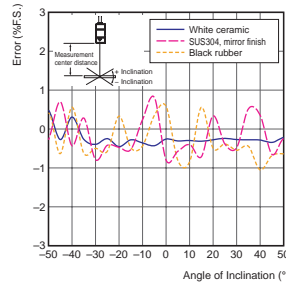

ZX1-LD600□

Side-to-side Inclination

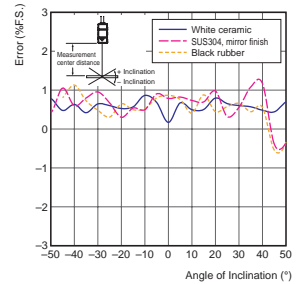

ZX1-LD50□

Front-to-back Inclination

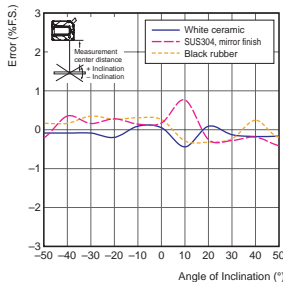

ZX1-LD100□

Front-to-back Inclination

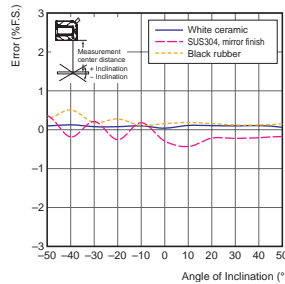

ZX1-LD300□

Front-to-back Inclination

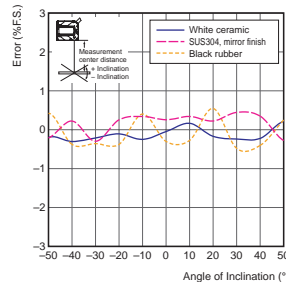

ZX1-LD600□

Front-to-back Inclination

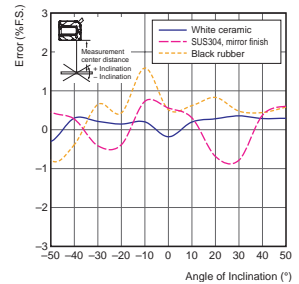

Linearity Characteristic for Different Materials

ZX1-LD50□

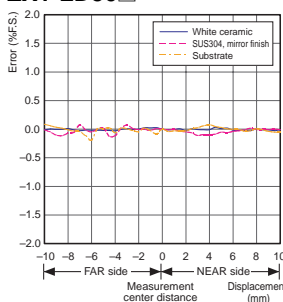

ZX1-LD100□

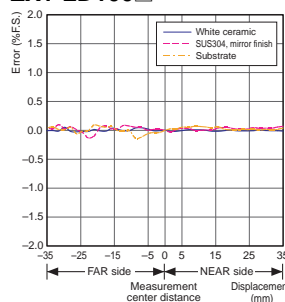

ZX1-LD300□

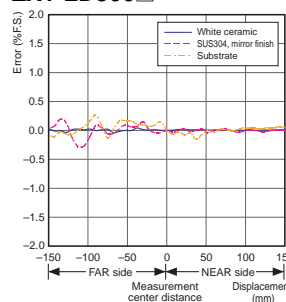

ZX1-LD600□

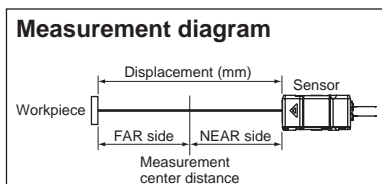
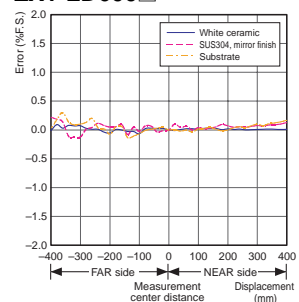

- Note:**
1. Measurement conditions for the ZX1-LD□□: Ambient temperature of 25°C in Standard Mode after executing Smart Tuning.
 2. The ambient conditions or workpiece may adversely affect the engineering data of the ZX1-LD□□L.
 3. The X-axis displacement indicates the measurement distance displayed on a digital display.
The measurement distance displayed on a digital display takes the measurement center distance as 0 and displays the near side of the Sensor as positive and the far side as negative.

ZX1

I/O Circuit Diagrams

NPN Output Model (Negative Common)

ZX1-LD50A61(L) / ZX1-LD50A66
 ZX1-LD100A61(L) / ZX1-LD100A66
 ZX1-LD300A61(L) / ZX1-LD300A66
 ZX1-LD600A61(L) / ZX1-LD600A66

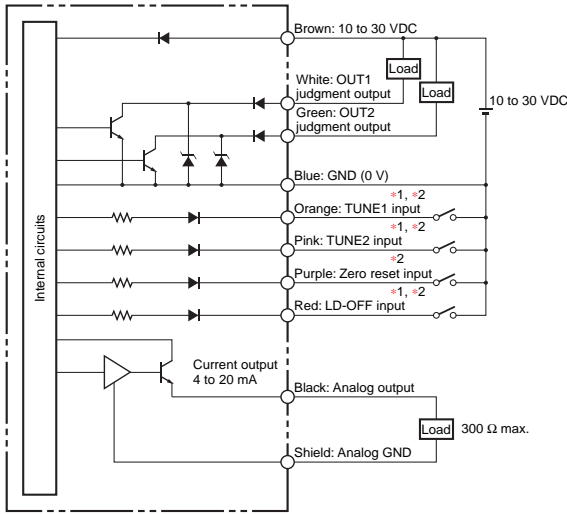

PNP Output Model (Positive Common)

ZX1-LD50A81(L) / ZX1-LD50A86
 ZX1-LD100A81(L) / ZX1-LD100A86
 ZX1-LD300A81(L) / ZX1-LD300A86
 ZX1-LD600A81(L) / ZX1-LD600A86

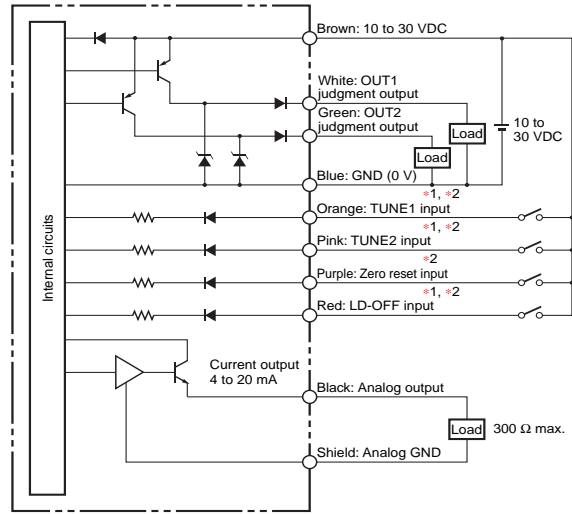

- *1. TUNE1 input: tuning external input for channel 1
 TUNE2 input: tuning external input for channel 2
 LD-OFF input: Laser OFF input
- *2. The input specification is as follows:

	NPN Output Model	PNP Output Model
ON	Short-circuited with 0-V terminal or 1.5 V max.	Supply voltage short-circuited or supply voltage within -1.5 V
OFF	Open (leakage current: 0.1 mA max.)	Open (leakage current: 0.1 mA max.)

Timing Charts

TUNE1 Input / TUNE2 Input

(1) Time identification tuning type

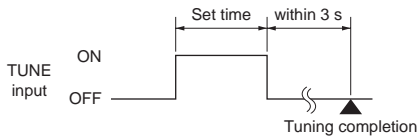

(2) Tuning type other than time identification

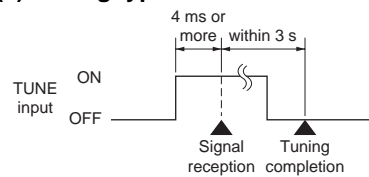

Zero Reset Input

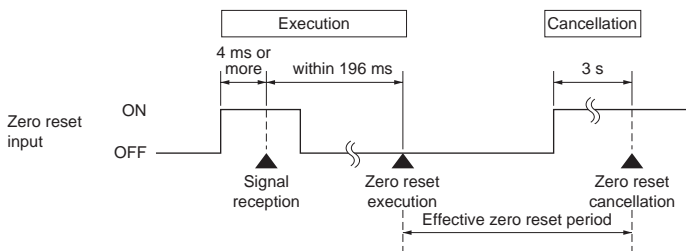

LD-OFF Input

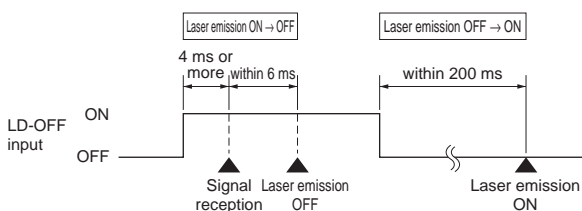

Safety Precautions

This datasheet contains information only for selecting the appropriate model. Be sure to read the Instruction Sheet for usage precautions prior to using the product.

Laser Safety

WARNING

ZX1-LD□□□: Class 2, ZX1-LD□□□L: Class1

Do not expose your eyes to the laser radiation either directly or indirectly (i.e., after reflection from a mirror or shiny surface).



The laser radiation has a high power density and exposure may result in loss of sight.

Do not disassemble the product.

Doing so may cause the laser beam to leak, resulting in the danger of visual impairment.



Note: For Precautions for safe use and Precautions for correct use, refer to the Instruction Sheet supplied with the product.

Dimensions

Tolerance class IT16 applies to dimensions in this datasheet unless otherwise specified.

Sensors

Pre-wired Models

- ZX1-LD50A61(L)
- ZX1-LD50A81(L)
- ZX1-LD100A61(L)
- ZX1-LD100A81(L)

Pre-wired Connector Models

- ZX1-LD50A66
- ZX1-LD50A86
- ZX1-LD100A66
- ZX1-LD100A86

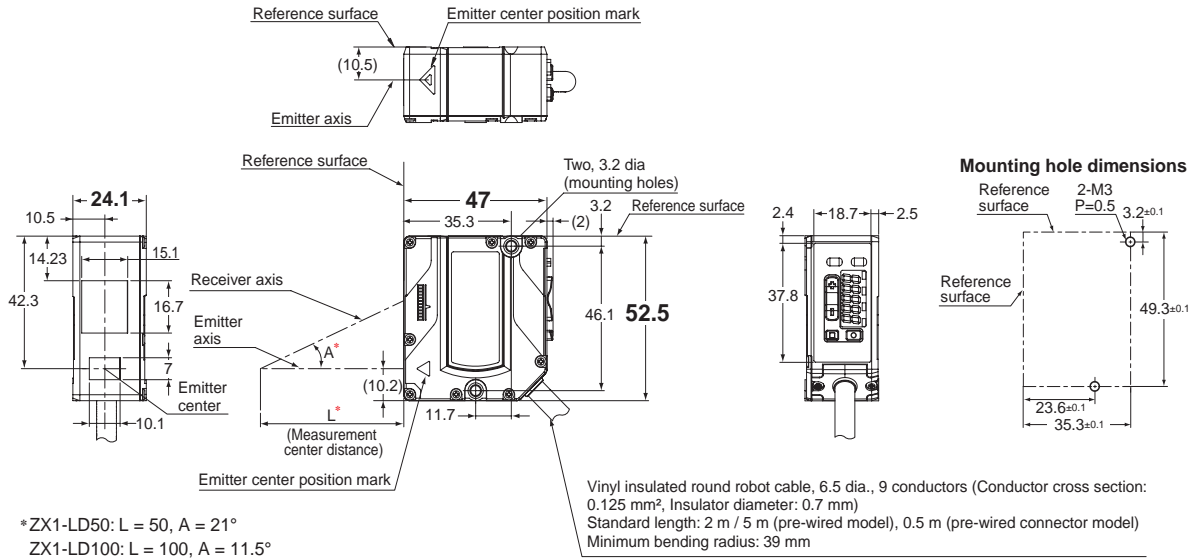

Pre-wired Models

- ZX1-LD300A61(L)
- ZX1-LD300A81(L)
- ZX1-LD600A61(L)
- ZX1-LD600A81(L)

Pre-wired Connector Models

- ZX1-LD300A66
- ZX1-LD300A86
- ZX1-LD600A66
- ZX1-LD600A86

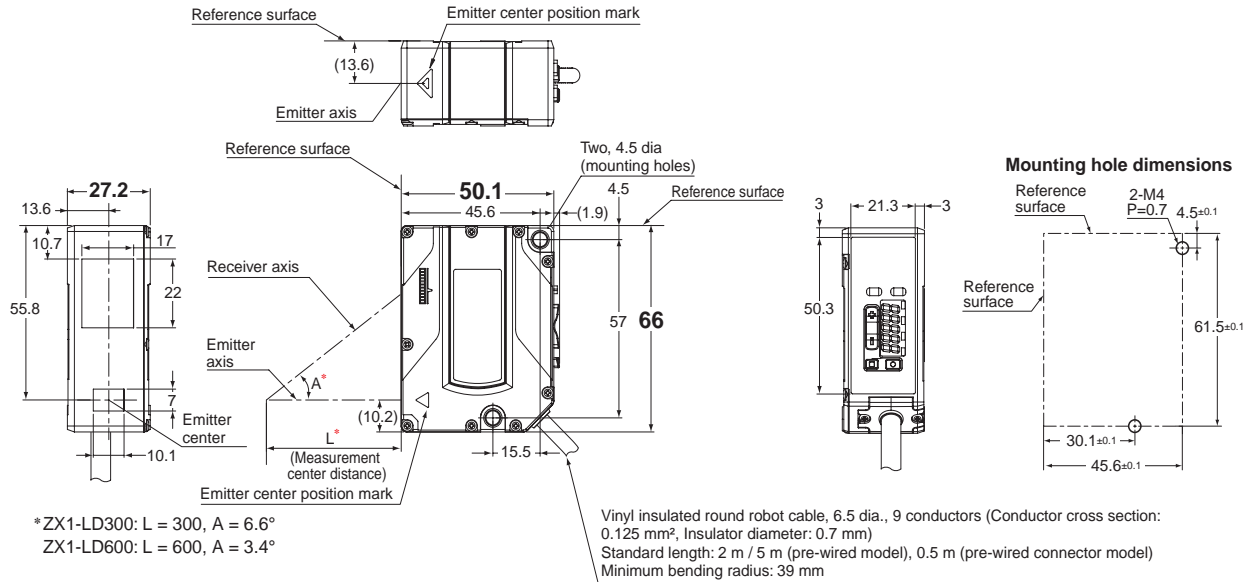

Display, Indicators, and Controls

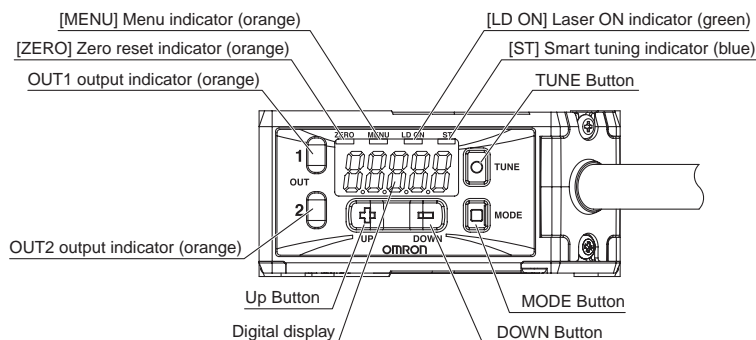

Pre-wired connector

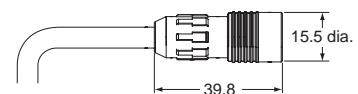

Accessories (sold separately)

Extension Cables for Pre-wired Connector Models

ZX0-XC10R (10 m)

ZX0-XC20R (20 m)

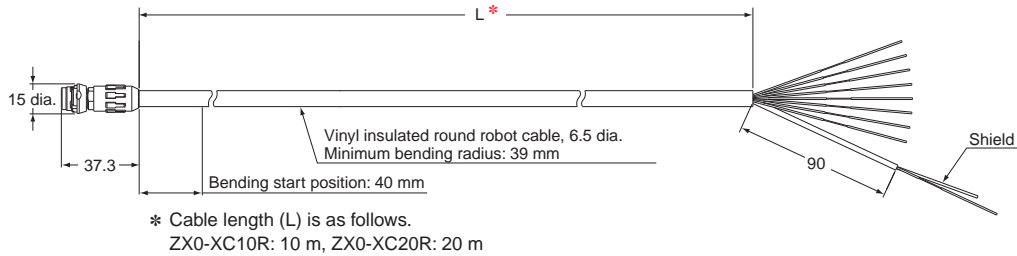

Mounting Bracket for ZX1-LD50□/ZX1-LD100□ E39-L180

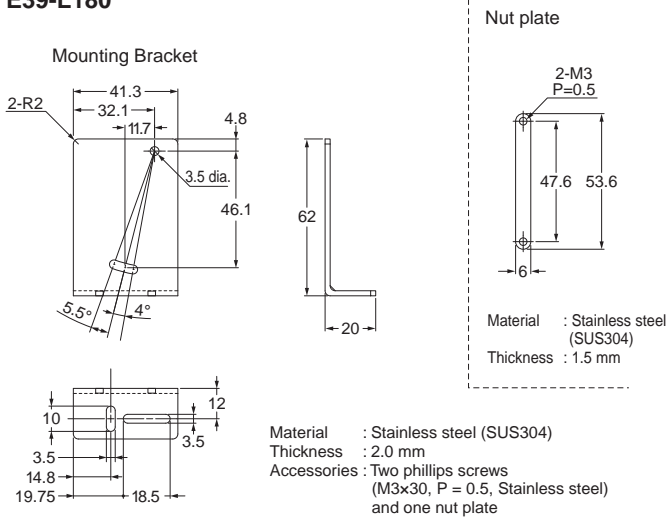

Mounting Bracket for ZX1-LD300□/ZX1-LD600□ E39-L181

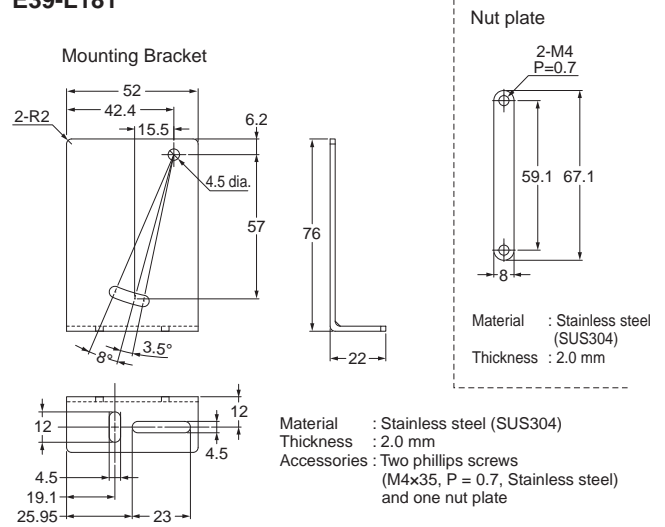

Installation Method (ZX1-LD50□/ZX1-LD100□) Using E39-L180 Mounting Bracket

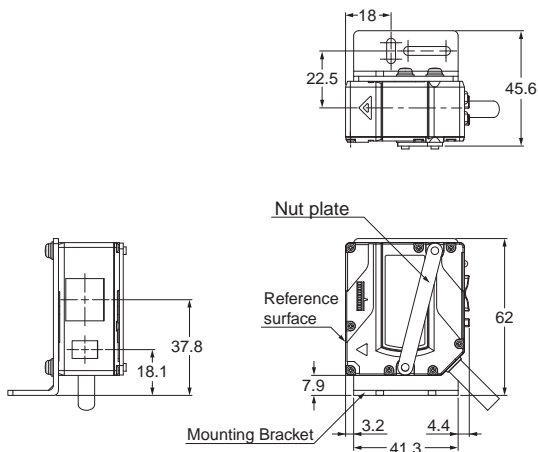

Installation Method (ZX1-LD300□/ZX1-LD600□) Using E39-L181 Mounting Bracket

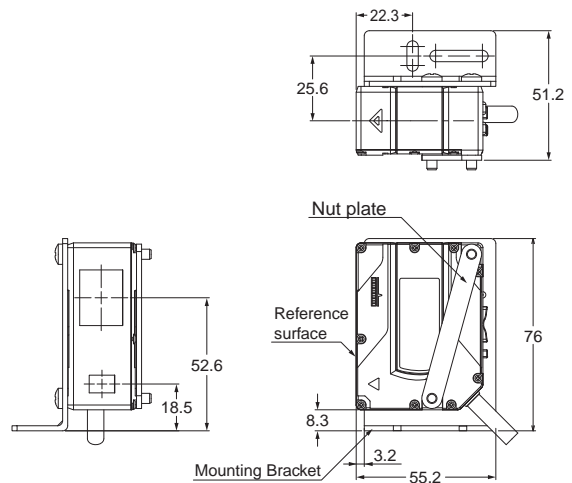

READ AND UNDERSTAND THIS DOCUMENT

Please read and understand this document before using the products. Please consult your OMRON representative if you have any questions or comments.

WARRANTY

OMRON's exclusive warranty is that the products are free from defects in materials and workmanship for a period of one year (or other period if specified) from date of sale by OMRON.

OMRON MAKES NO WARRANTY OR REPRESENTATION, EXPRESS OR IMPLIED, REGARDING NON-INFRINGEMENT, MERCHANTABILITY, OR FITNESS FOR PARTICULAR PURPOSE OF THE PRODUCTS. ANY BUYER OR USER ACKNOWLEDGES THAT THE BUYER OR USER ALONE HAS DETERMINED THAT THE PRODUCTS WILL SUITABLY MEET THE REQUIREMENTS OF THEIR INTENDED USE. OMRON DISCLAIMS ALL OTHER WARRANTIES, EXPRESS OR IMPLIED.

LIMITATIONS OF LIABILITY

OMRON SHALL NOT BE RESPONSIBLE FOR SPECIAL, INDIRECT, OR CONSEQUENTIAL DAMAGES, LOSS OF PROFITS OR COMMERCIAL LOSS IN ANY WAY CONNECTED WITH THE PRODUCTS, WHETHER SUCH CLAIM IS BASED ON CONTRACT, WARRANTY, NEGLIGENCE, OR STRICT LIABILITY.

In no event shall responsibility of OMRON for any act exceed the individual price of the product on which liability is asserted.

IN NO EVENT SHALL OMRON BE RESPONSIBLE FOR WARRANTY, REPAIR, OR OTHER CLAIMS REGARDING THE PRODUCTS UNLESS OMRON'S ANALYSIS CONFIRMS THAT THE PRODUCTS WERE PROPERLY HANDLED, STORED, INSTALLED, AND MAINTAINED AND NOT SUBJECT TO CONTAMINATION, ABUSE, MISUSE, OR INAPPROPRIATE MODIFICATION OR REPAIR.

SUITABILITY FOR USE

THE PRODUCTS CONTAINED IN THIS DOCUMENT ARE NOT SAFETY RATED. THEY ARE NOT DESIGNED OR RATED FOR ENSURING SAFETY OF PERSONS, AND SHOULD NOT BE RELIED UPON AS A SAFETY COMPONENT OR PROTECTIVE DEVICE FOR SUCH PURPOSES. Please refer to separate catalogs for OMRON's safety rated products.

OMRON shall not be responsible for conformity with any standards, codes, or regulations that apply to the combination of products in the customer's application or use of the product.

At the customer's request, OMRON will provide applicable third party certification documents identifying ratings and limitations of use that apply to the products. This information by itself is not sufficient for a complete determination of the suitability of the products in combination with the end product, machine, system, or other application or use.

The following are some examples of applications for which particular attention must be given. This is not intended to be an exhaustive list of all possible uses of the products, nor is it intended to imply that the uses listed may be suitable for the products:

- Outdoor use, uses involving potential chemical contamination or electrical interference, or conditions or uses not described in this document.
- Nuclear energy control systems, combustion systems, railroad systems, aviation systems, medical equipment, amusement machines, vehicles, safety equipment, and installations subject to separate industry or government regulations.
- Systems, machines, and equipment that could present a risk to life or property.

Please know and observe all prohibitions of use applicable to the products.

NEVER USE THE PRODUCTS FOR AN APPLICATION INVOLVING SERIOUS RISK TO LIFE OR PROPERTY WITHOUT ENSURING THAT THE SYSTEM AS A WHOLE HAS BEEN DESIGNED TO ADDRESS THE RISKS, AND THAT THE OMRON PRODUCT IS PROPERLY RATED AND INSTALLED FOR THE INTENDED USE WITHIN THE OVERALL EQUIPMENT OR SYSTEM.

PERFORMANCE DATA

Performance data given in this document is provided as a guide for the user in determining suitability and does not constitute a warranty. It may represent the result of OMRON's test conditions, and the users must correlate it to actual application requirements. Actual performance is subject to the OMRON Warranty and Limitations of Liability.

CHANGE IN SPECIFICATIONS

Product specifications and accessories may be changed at any time based on improvements and other reasons.

It is our practice to change model numbers when published ratings or features are changed, or when significant construction changes are made. However, some specifications of the product may be changed without any notice. When in doubt, special model numbers may be assigned to fix or establish key specifications for your application on your request. Please consult with your OMRON representative at any time to confirm actual specifications of purchased products.

DIMENSIONS AND WEIGHTS

Dimensions and weights are nominal and are not to be used for manufacturing purposes, even when tolerances are shown.

ERRORS AND OMISSIONS

The information in this document has been carefully checked and is believed to be accurate; however, no responsibility is assumed for clerical, typographical, or proofreading errors, or omissions.

PROGRAMMABLE PRODUCTS

OMRON shall not be responsible for the user's programming of a programmable product, or any consequence thereof.

COPYRIGHT AND COPY PERMISSION

This document shall not be copied for sales or promotions without permission.

This document is protected by copyright and is intended solely for use in conjunction with the product. Please notify us before copying or reproducing this document in any manner, for any other purpose. If copying or transmitting this document to another, please copy or transmit it in its entirety.

ALL DIMENSIONS SHOWN ARE IN MILLIMETERS.
To convert millimeters into inches, multiply by 0.03937. To convert grams into ounces, multiply by 0.03527.

OMRON Corporation Industrial Automation Company
Tokyo, JAPAN

Contact: www.ia.omron.com

Regional Headquarters

OMRON EUROPE B.V.
Sensor Business Unit
Carl-Benz-Str. 4, D-71154 Nufringen, Germany
Tel: (49) 7032-811-0/Fax: (49) 7032-811-199

OMRON ELECTRONICS LLC
One Commerce Drive Schaumburg,
IL 60173-5302 U.S.A.
Tel: (1) 847-843-7900/Fax: (1) 847-843-7787

OMRON ASIA PACIFIC PTE. LTD.
No. 438A Alexandra Road # 05-05/08 (Lobby 2),
Alexandra Technopark,
Singapore 119967
Tel: (65) 6835-3011/Fax: (65) 6835-2711

OMRON (CHINA) CO., LTD.
Room 2211, Bank of China Tower,
200 Yin Cheng Zhong Road,
PuDong New Area, Shanghai, 200120, China
Tel: (86) 21-5037-2222/Fax: (86) 21-5037-2200

Authorized Distributor:

© OMRON Corporation 2011 All Rights Reserved.
In the interest of product improvement,
specifications are subject to change without notice.

CSM_3_1_1114
Cat. No. E416-E1-02

Printed in Japan
0112(1111)

Mouser Electronics

Authorized Distributor

Click to View Pricing, Inventory, Delivery & Lifecycle Information:

Omron:

[ZX1-LD50A81 5M](#) [ZX1-LD50A61 5M](#)

Компания «Океан Электроники» предлагает заключение долгосрочных отношений при поставках импортных электронных компонентов на взаимовыгодных условиях!

Наши преимущества:

- Поставка оригинальных импортных электронных компонентов напрямую с производств Америки, Европы и Азии, а так же с крупнейших складов мира;
- Широкая линейка поставок активных и пассивных импортных электронных компонентов (более 30 млн. наименований);
- Поставка сложных, дефицитных, либо снятых с производства позиций;
- Оперативные сроки поставки под заказ (от 5 рабочих дней);
- Экспресс доставка в любую точку России;
- Помощь Конструкторского Отдела и консультации квалифицированных инженеров;
- Техническая поддержка проекта, помощь в подборе аналогов, поставка прототипов;
- Поставка электронных компонентов под контролем ВП;
- Система менеджмента качества сертифицирована по Международному стандарту ISO 9001;
- При необходимости вся продукция военного и аэрокосмического назначения проходит испытания и сертификацию в лаборатории (по согласованию с заказчиком);
- Поставка специализированных компонентов военного и аэрокосмического уровня качества (Xilinx, Altera, Analog Devices, Intersil, Interpoint, Microsemi, Actel, Aeroflex, Peregrine, VPT, Syfer, Eurofarad, Texas Instruments, MS Kennedy, Miteq, Cobham, E2V, MA-COM, Hittite, Mini-Circuits, General Dynamics и др.);

Компания «Океан Электроники» является официальным дистрибьютором и эксклюзивным представителем в России одного из крупнейших производителей разъемов военного и аэрокосмического назначения «JONHON», а так же официальным дистрибьютором и эксклюзивным представителем в России производителя высокотехнологичных и надежных решений для передачи СВЧ сигналов «FORSTAR».



JONHON

«JONHON» (основан в 1970 г.)

Разъемы специального, военного и аэрокосмического назначения:

(Применяются в военной, авиационной, аэрокосмической, морской, железнодорожной, горно- и нефтедобывающей отраслях промышленности)

«FORSTAR» (основан в 1998 г.)

ВЧ соединители, коаксиальные кабели, кабельные сборки и микроволновые компоненты:

(Применяются в телекоммуникациях гражданского и специального назначения, в средствах связи, РЛС, а так же военной, авиационной и аэрокосмической отраслях промышленности).



Телефон: 8 (812) 309-75-97 (многоканальный)

Факс: 8 (812) 320-03-32

Электронная почта: ocean@oceanchips.ru

Web: <http://oceanchips.ru/>

Адрес: 198099, г. Санкт-Петербург, ул. Калинина, д. 2, корп. 4, лит. А