

**Circuits
from the Lab®**
Reference Designs

Circuits from the Lab® reference designs are engineered and tested for quick and easy system integration to help solve today's analog, mixed-signal, and RF design challenges. For more information and/or support, visit www.analog.com/CN0372.

Devices Connected/Referenced

AD7091R-5	4-Channel, I ² C, Ultralow Power, 12-Bit ADC
ADP5090	Ultralow Power Boost Regulator with MPPT and Charge Management
ADA4805-1	0.2 $\mu\text{V}/^\circ\text{C}$ Offset Drift, 105 MHz Low Power, Low Noise, Rail-to-Rail Amplifier
ADP1607	2 MHz, Synchronous Boost DC-to-DC Converter

Ultralow Power, General-Purpose, Multichannel Data Acquisition System with Energy Harvesting Circuit and Alert Function

EVALUATION AND DESIGN SUPPORT

Circuit Evaluation Boards

- [CN-0372 Circuit Evaluation Board \(EVAL-CN0372-PMDZ\)](#)
- [System Demonstration Platform \(EVAL-SDP-CB1Z\)](#)
- [SDP-I-PMOD Interposer Board \(SDP-PMD-IB1Z\)](#)

Design and Integration Files

- [Schematics, Layout Files, Bill of Materials](#)

CIRCUIT FUNCTION AND BENEFITS

The circuit shown in Figure 1 is an ultralow power, multichannel data acquisition system that can be powered by a photovoltaic (PV) cell or thermoelectric generator (TEG). The circuit uses the industry's lowest power, multichannel, 12-bit successive approximation analog-to-digital converter (SAR ADC), the [AD7091R-5](#), along with an efficient energy harvesting circuit based on the [ADP5090](#) boost regulator. The ADC has a typical power consumption of 100 μW on a single 3 V supply when sampling at 22 kSPS. Typical signal-to-noise ratio (SNR) is 68 dB for a 1 kHz input signal.

The low power consumption and small form factor make this combination of devices ideally suited for portable low power applications, particularly for wearable and self-powered devices.

Rev. 0

Circuits from the Lab® reference designs from Analog Devices have been designed and built by Analog Devices engineers. Standard engineering practices have been employed in the design and construction of each circuit, and their function and performance have been tested and verified in a lab environment at room temperature. However, you are solely responsible for testing the circuit and determining its suitability and applicability for your use and application. Accordingly, in no event shall Analog Devices be liable for direct, indirect, special, incidental, consequential or punitive damages due to any cause whatsoever connected to the use of any Circuits from the Lab circuits. (Continued on last page)

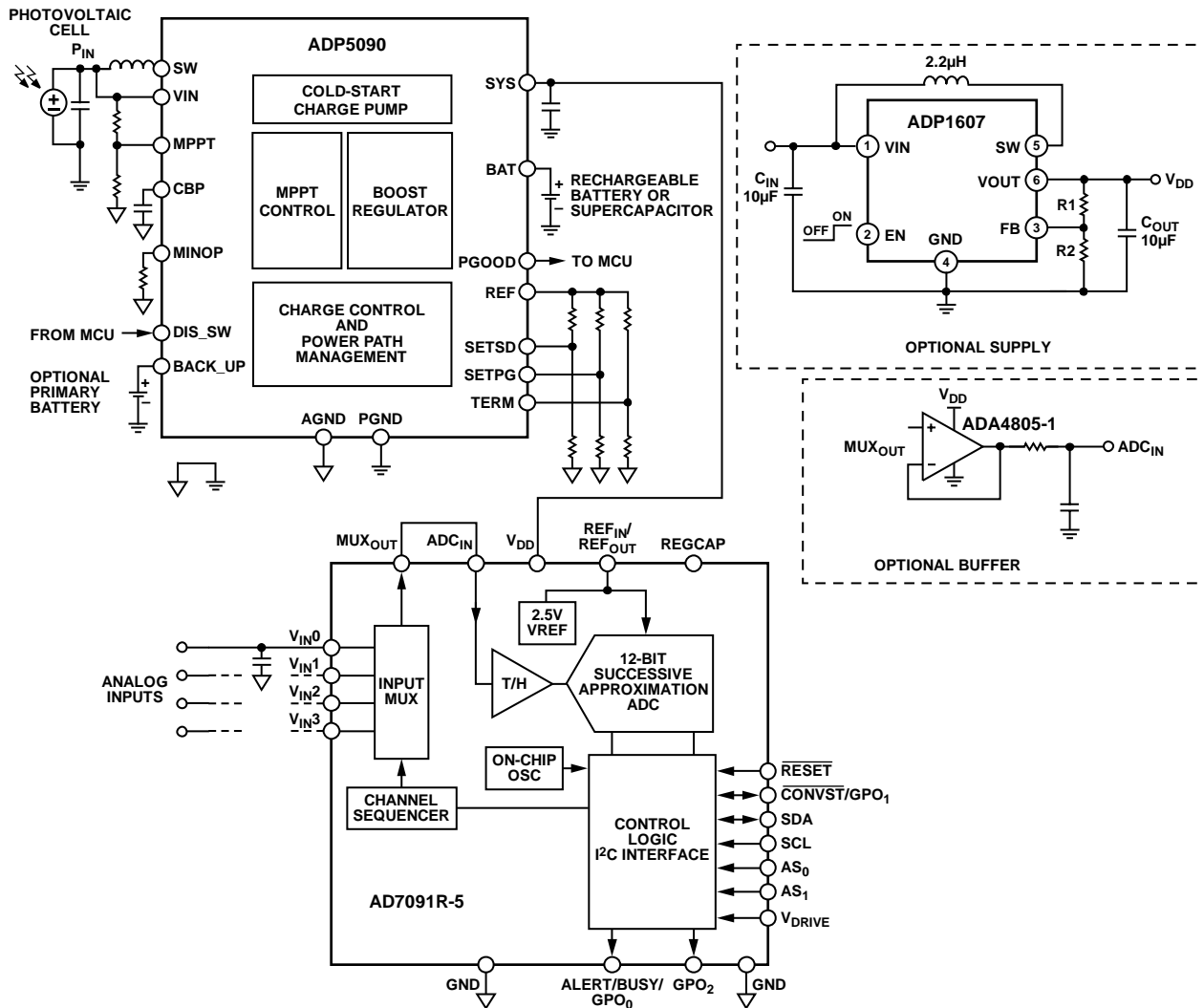

Figure 1. Low Power Data Acquisition System with Energy Harvesting Circuit (Simplified Schematic: All Connections and Decoupling Not Shown)

CIRCUIT DESCRIPTION

This circuit provides an optimized low power compact solution for multichannel system monitoring. These characteristics are particularly important in wearable and self-powered applications where form factor and power consumption are critical system specifications.

Analog-to-Digital Converter

The AD7091R-5 is a 12-bit, ultralow power, successive approximation ADC. The device operates from a single 2.7 V to 5.25 V power supply. This ADC features an on-chip conversion clock, an accurate reference, and an I²C interface that operates in both standard ($f_{SCL} = 100$ kHz) and fast ($f_{SCL} = 400$ kHz) modes.

The conversion process and data acquisition are controlled using the I²C interface and an internal oscillator. The AD7091R-5 interface allows data read after the conversion, achieving a maximum 22.22 kSPS throughput rate in fast mode. This device uses advanced design and process techniques to achieve ultralow power dissipation without compromising performance.

An on-chip, accurate 2.5 V reference is available on the REF_{IN}/REF_{OUT} pin.

The AD7091R-5 has an autcycle mode that allows the user to configure the ADC for autonomous operation and is ideal for the monitoring of events outside of a user defined range. Conversions automatically take place at configured intervals as shown in Table 25 of the AD7091R-5 data sheet. Typically, this mode is used to monitor a selection of channels with limit registers programmed to signal out of bounds conditions via the alert function.

Energy Harvester

The ADP5090 is an integrated boost regulator that converts dc power from photovoltaic cells or thermoelectric generators. The device charges storage elements (rechargeable battery or super capacitor). The CN-0372 board uses a super capacitor that supplies power for small electronic devices and battery-free systems. The ADP5090 provides efficient conversion of the small amounts of harvested power available from PV cells or TEGs. The ADP5090 operates on an input power range from 16 μW to 200 mW range with sub-microwatt operation losses.

With the internal cold-start circuit, the regulator can start operating at an input voltage as low as 380 mV. This solution eliminates the need for an external battery to power the circuit (although backup battery options are available) and makes full use of harvestable energy instead.

The SYS voltage output of the [ADP5090](#) supplies the entire circuit as shown in Figure 1.

Circuit Design

The circuit in Figure 2 shows the minimal connections needed for the [AD7091R-5](#) ADC.

The analog input range for the [AD7091R-5](#) is 0 V to V_{REF} and is unipolar. The circuit is not designed to accept negative voltages. While the [AD7091R-5](#) contains a wide bandwidth track-and-hold amplifier that can handle input frequencies up to 1.5 MHz, the circuit is tested to resolve lower frequencies up to 2 kHz in fast mode.

The [AD7091R-5](#) provides access to the multiplexer output eliminating the need for a signal conditioning circuit in each channel when additional filtering is required. The input signal of the active channel appears at MUX_{OUT} . The filters before the ADC V_{IN} pins are designed to have a cutoff frequency of about 8.6 MHz. These filters attenuate noise at the ADC input and absorb the charge kickbacks from the ADC. It is recommended to use a low series resistance value and a reasonably sized capacitor that can source and sink the high frequency charge kickbacks from the ADC.

If no additional filtering or signal conditioning is required, the MUX_{OUT} pin is tied directly to ADC_{IN} . Control of the [AD7091R-5](#) is through the I²C-compatible serial bus.

Figure 3 shows the [ADP5090](#) energy harvesting circuit. The circuit converts power from an energy source connected to the J4 terminal, stores charge in the super capacitor (C26), and provides power to the entire circuit.

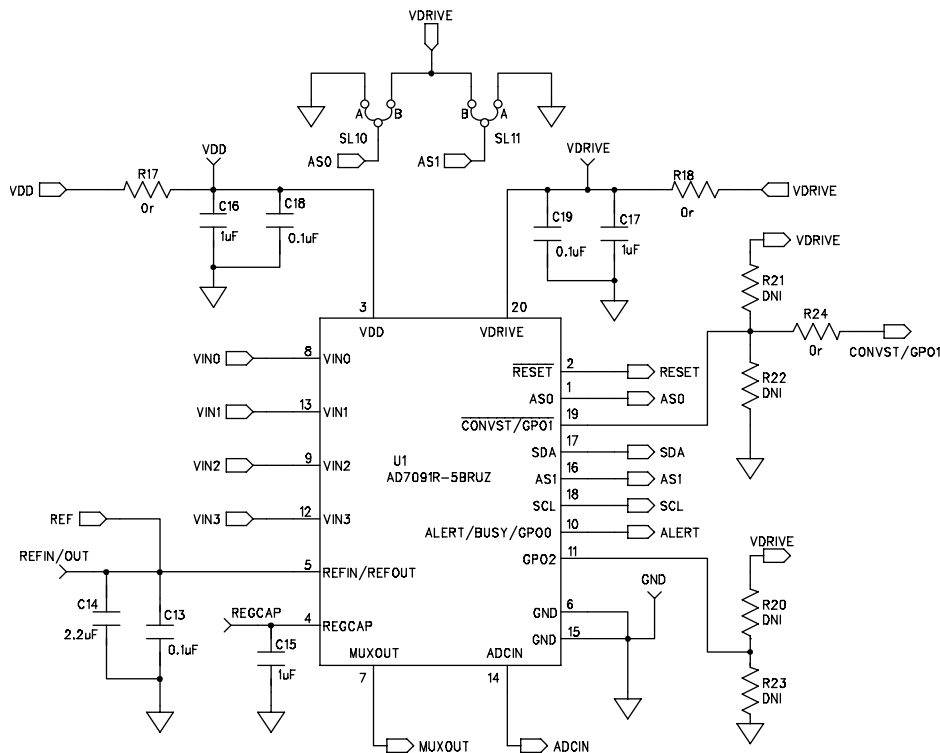

Figure 2. CN-0372 ADC Connection (Simplified Schematic: All Connections Not Shown)

1395B2-002

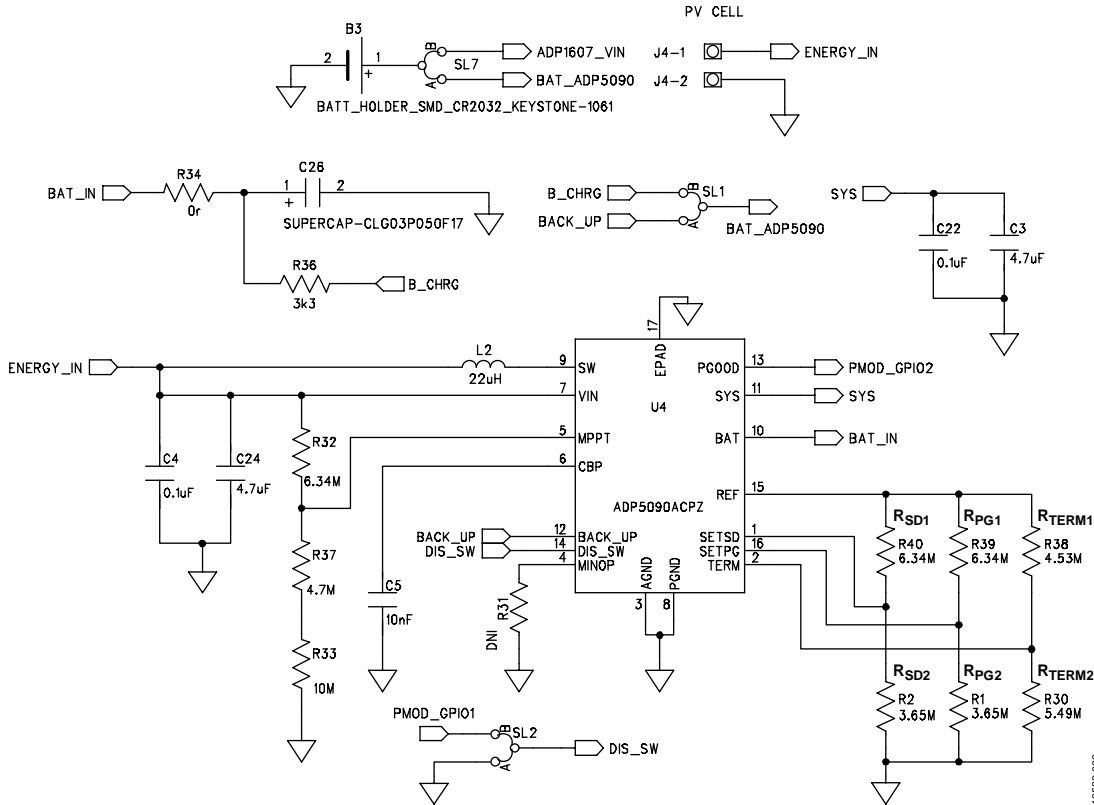

Figure 3. CN-0372 Energy Harvesting Circuit

Harvested energy from a PV cell or TEG is introduced at ENERGY_IN. When ENERGY_IN exceeds 380 mV, the ADP5090 enters cold start-up. The device then exits cold-startup, and main boost is enabled when the SYS voltage exceeds V_{SYS_TH} , which is typically 1.93 V. The logic high level on PGOOD is equal to the SYS voltage, and when the battery terminal voltage is reached, the main boost charger is turned off.

The ADP5090 boost regulator operates in pulse frequency mode (PFM), transferring energy stored in the input capacitor to SYS and the C26 super capacitor (Cellergy CLG03P050F17, 50 mF, 3.5 V). A PGOOD threshold is set by external connectors to indicate that the SYS voltage is at an acceptable voltage, given by

$$V_{SYS_PGOOD} = V_{REF_ADP5090} \left(1 + \frac{R_{PG1}}{R_{PG2}} \right), \sim 3.3 \text{ V}$$

where:

R_{PG1} and R_{PG2} are the values from Figure 3.

$V_{REF_ADP5090}$ is typically 1.21 V.

The ADP5090 is also equipped with battery overcharging and discharging protection thresholds, which are also set by external resistors.

To prevent overcharging, the rising threshold for the battery terminal voltage is given by

$$V_{BAT_TERM} = \frac{3}{2} V_{REF_ADP5090} \left(1 + \frac{R_{TERM1}}{R_{TERM2}} \right), \sim 3.3 \text{ V}$$

where R_{TERM1} and R_{TERM2} are the values from Figure 3.

To prevent deep discharge, the falling threshold for the battery discharge shutdown voltage is given by

$$V_{BAT_SD} = V_{REF_ADP5090} \left(1 + \frac{R_{SD1}}{R_{SD2}} \right), \sim 3.3 \text{ V}$$

where R_{SD1} and R_{SD2} are the values from Figure 3.

An illustration of these threshold voltages is shown in Figure 4.

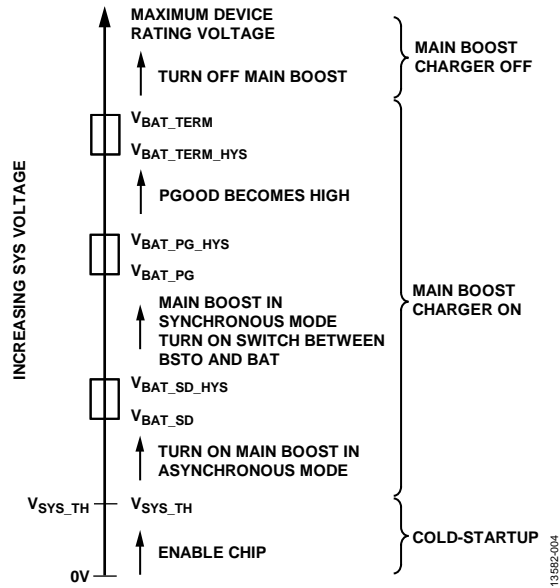

Figure 4. States of Various Threshold Voltages

The circuit in Figure 3 also has a provision through SL7 to provide a low energy state backup option to accelerate cold-start.

A complete documentation package including schematics, board layout, and bill of materials (BOM) can be found at www.analog.com/CN0372-DesignSupport. The circuit is compatible with the Digilent PMOD interface standard.

Measurement Results for DAS with Energy Harvesting Circuit

The circuit comes with a graphical user interface that facilitates configuring the devices on-board and evaluating the circuit performance. Tabs are available for device configuration, as well as for displaying noise performance, histogram, and register readout. For a complete description of the software package, see the [CN-0372 Software User Guide](#).

Figure 5 and Figure 6 show the ac performance of the circuit, configured with MUX_{OUT} connected directly to ADC_{IN}, for a 2.4 V p-p, 1 kHz sine wave with a common-mode voltage of 1.25 V. While the default configuration generates a 3.3 V supply on SYS, all measurements in this circuit note were taken with the external resistors configured for 3 V supplies.

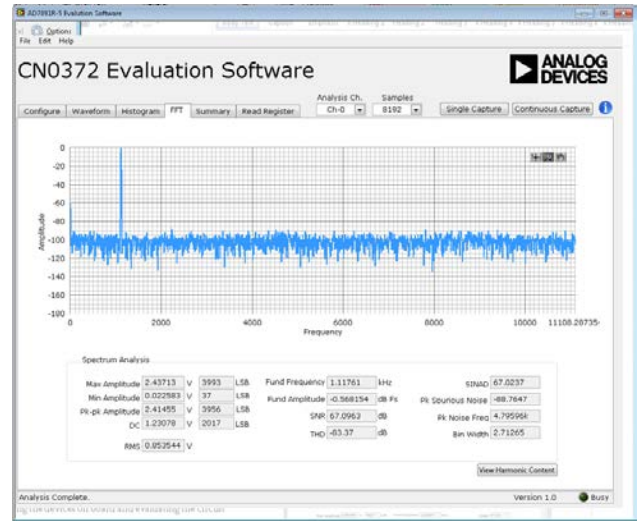

Figure 5. CN-0372 AC Performance

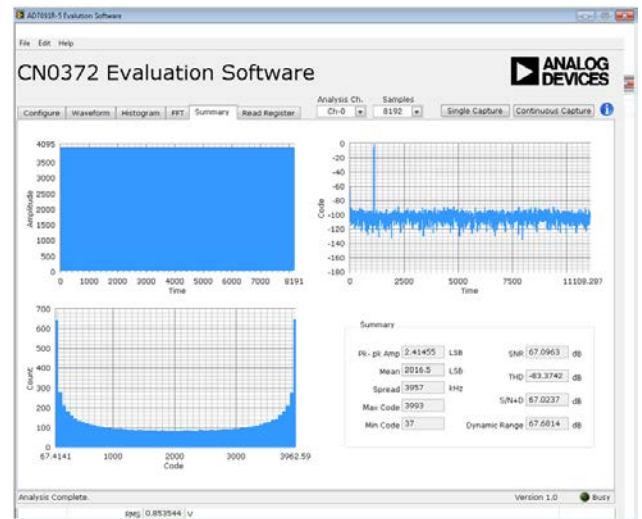

Figure 6. CN-0372 AC Performance Full Summary

Power consumed is computed using the following equation:

$$P_T = I_T \times V_S$$

where:

P_T is the total consumed power.

I_T is the total current consumption measured in series with V_{DD} .

V_S is the supply voltage at V_{DD} .

The circuit, configured without the buffer and with V_{DD} and V_{DRIVE} coming from SYS, consumes 34 μ A.

COMMON VARIATIONS

An on-board option for external buffering of the MUX_{OUT} signal using an ADA4805-1 is available, as well as an option to use the backup battery to power an on-board ADP1607 regulator to generate the board supply rails.

Figure 7 shows the on-board optional buffer circuitry. When used, R6 is removed, SL9 and SL12 are set to Position B, SL13 is set to Position A, and R43 is installed. The circuit also has

provisions for any gain, attenuation, or level shifting that is desired. The ADA4805-1 consumes approximately 500 μA of quiescent current, but has the option to power down and scale with throughput. As shown in Figure 8, controlling the ADA4805-1 SHUTDOWN pin allows users to dynamically manage its power consumption. Adjusting the duty cycle of the SHUTDOWN signal through the evaluation software achieves significant power savings.

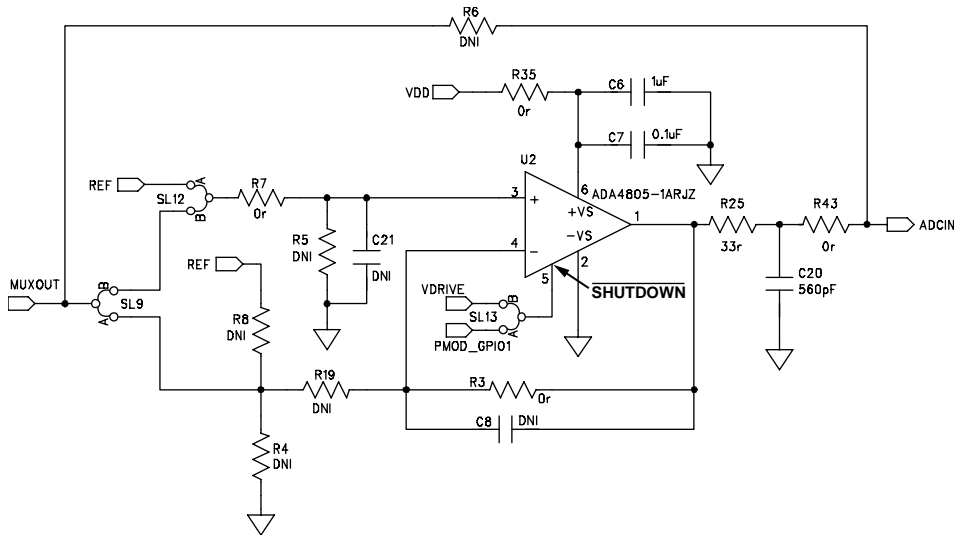

Figure 7. Optional Buffer Circuitry

13582-007

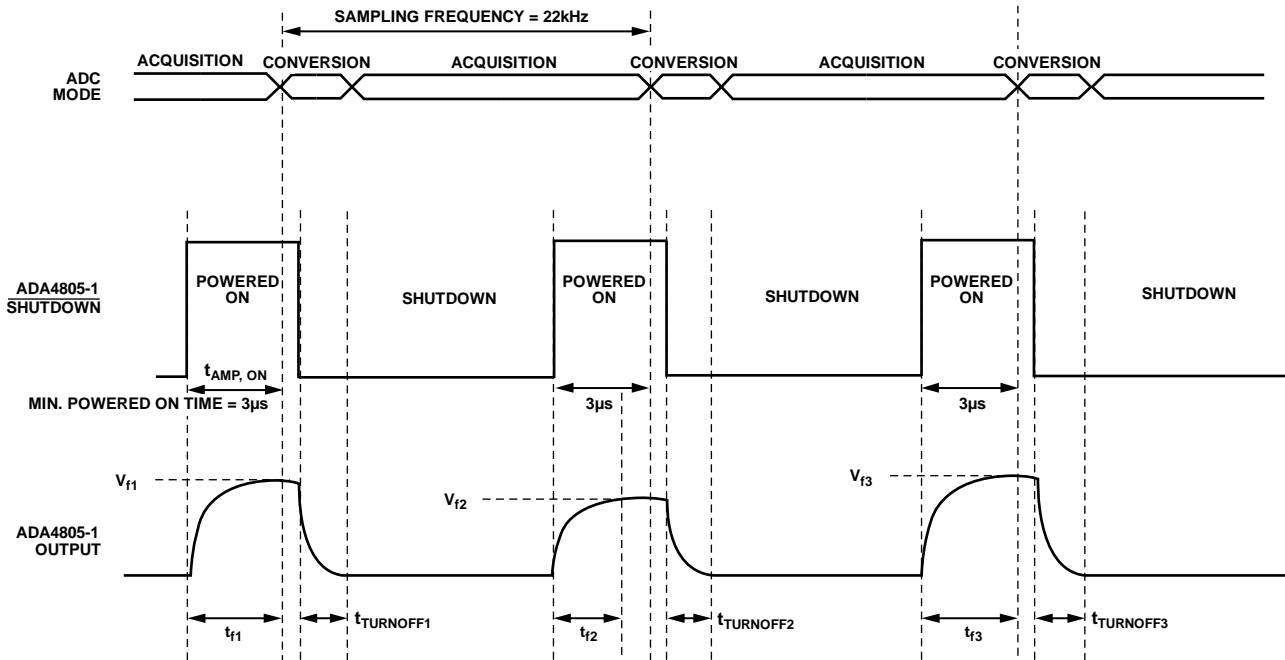

Figure 8. Dynamic Power Scaling with ADA4805-1

13582-008

See the [CN-0372 Software User Guide](#) for additional details on controlling the power-scaling feature of the [ADA4805-1](#) in the evaluation software.

With power scaling, the equation for consumed power becomes

$$P_T = I_T \times V_S + I_Q \times V_S \times \frac{t_{AMP, ON}}{t_S}$$

where:

P_T is the total consumed power.

I_Q is the quiescent current.

$t_{AMP, ON}$ is the time the [ADA4805-1](#) is on.

t_S is the sampling time.

Overall system consumption with the [ADA4805-1](#) in use and dynamically powered, and with VDD and VDRIVE coming from SYS, was as low as 70 μA without performance degradation, as shown in Figure 9.

Table 1 shows typical current consumption of the circuit at different configurations.

Table 1. Current Consumption at Different Configurations

Configuration	Current (μA)
Without Buffer Amplifier	34
AD7091R-5 in Full Power Down	13.4
AD7091R-5 in Full Power Down, No Internal Reference	0.5
With Buffer Amplifier Always On	530
AD7091R-5 in Full Power Down	520.4
AD7091R-5 in Full Power Down, No Internal Reference	507.3
Dynamic Power Scaling with Buffer Amplifier	See Figure 9

Typical performance and current consumption of the system with different duty cycles is shown in Figure 9.

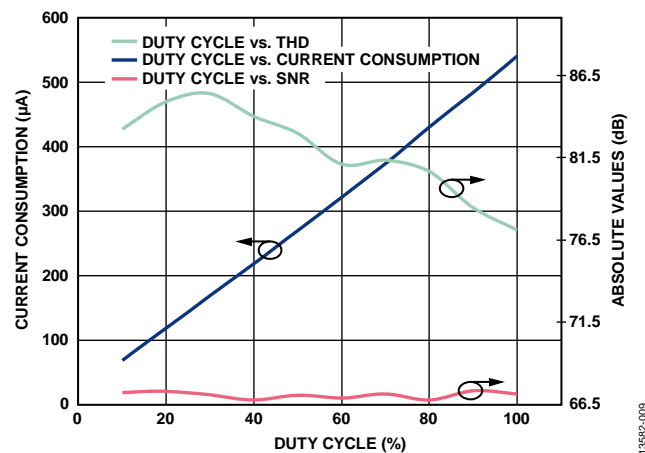

Figure 9. Current Consumption and AC Performance with Varying Duty Cycle in Fast Mode

Figure 10 shows the optional [ADP1607](#) circuitry, which can be configured through SL7 to be powered by the B3 backup battery in Figure 3.

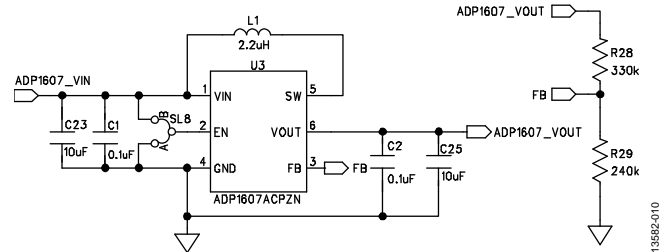

Figure 10. Optional Regulator Circuitry

The output voltage is configured by the R28 and R29 external resistors for a 3 V output using the following equation:

$$V_{OUT} = V_{FB} \left(1 + \frac{R28}{R29} \right) + I_{FB} \times R28$$

where:

$V_{FB} = 1.259 V$.

$I_{FB} = 0.1 \mu A$.

CIRCUIT EVALUATION AND TEST

This circuit uses the [EVAL-CN0372-PMDZ](#) circuit board, the [SDP-PMD-IB1Z](#) interposer board, and the [EVAL-SDP-CB1Z](#) system demonstration platform (SDP) board. The PMOD interposer board and the SDP controller board have 120-pin mating connectors. The interposer board and the [EVAL-CN0372-PMDZ](#) board have 12-pin PMOD interface Type 2A and 8-pin I²C interface matching connectors, allowing quick setup and evaluation of the circuit performance. The [EVAL-CN0372-PMDZ](#) board contains the circuit to be evaluated. The SDP controller board is used in conjunction with the [CN0372 Evaluation Software](#) to capture data and present results to the user.

Table 2. PMOD Interface Type 2A connection

Pin No.	Signal	Description
1	CONVST/GPO1	Connects to AD7091R-5 CONVST/GPO ₁ pin.
2, 3, 4	NC	No connection.
5, 11	GND	Connects to GND.
6, 12	VDD_PMOD	Connects to PMOD power supply.
7	ALERT	Connects to AD7091R-5 ALERT pin.
8	RESET	Connects to AD7091R-5 RESET pin.
9	PMOD_GPIO1	Connects to ADA4805-1 SHUTDOWN pin. Also connects to ADP5090 DIS_SW pin through SL2.
10	PMOD_GPIO2	Connects to ADP5090 PGOOD pin.

Table 3. I²C Interface Connection

Pin No.	Signal	Description
1, 2	SCL	Connects to AD7091R-5 SCL pin
3, 4	SDA	Connects to AD7091R-5 SDA pin
5, 6	GND	Connects to GND
7, 8	VDD_PMOD	Connects to PMOD power supply

Equipment Needed

The following equipment is needed:

- PC with a USB port and Windows® XP, Windows Vista® (32-bit), or Windows 7 (32-bit)
- [EVAL-CN0372-PMDZ](#) circuit evaluation board
- [EVAL-SDP-CB1Z](#) SDP controller board
- [SDP-PMD-IB1Z](#) interposer board
- 8-pin IDSD-04-D flexible cable: needed to connect the I²C interface between the [EVAL-CN0372-PMDZ](#) and [SDP-PMD-IB1Z](#) boards (included with the [EVAL-CN0372-PMDZ](#) board)
- [CN0372 Evaluation Software](#)
- Power supply: 6 V wall wart
- USB cable
- SRS DS360 ultralow distortion function generator or similar precision source
- Cymbet CBC-PV-01 PV cell: typical operating voltage is 0.8 V with an output current of approximately 200 μ A at 200 Lux in fluorescent light

Getting Started

Before connecting the boards to the PC, install the [CN0372 Evaluation Software](#). The most up to date version of the evaluation software can be downloaded from <ftp://ftp.analog.com/pub/cftl/CN0372>. Follow the on-screen prompts to finish the installation. It is recommended to install all software components to the default locations.

Connect the [EVAL-CN0372-PMDZ](#) in the desired regulator configuration, and connect the circuit evaluation board to the [SDP-PMD-IB1Z](#) interposer board.

Connect the I²C interface on the [EVAL-CN0372-PMDZ](#) board to the [SDP-PMD-IB1Z](#) interposer board with the 8-pin flexible cable.

Connect the [SDP-PMD-IB1Z](#) board to the [EVAL-SDP-CB1Z](#) controller board. Apply power to the [SDP-PMD-IB1Z](#) board, and connect the [EVAL-SDP-CB1Z](#) SDP controller board to the PC via the provided USB cable. Open the evaluation software and start evaluation.

Information regarding the [EVAL-SDP-CB1Z](#) can be found in the [SDP User Guide \(UG-277\)](#).

Functional Block Diagram

Figure 11 shows the functional block diagram of the test setup used for evaluating the circuit.

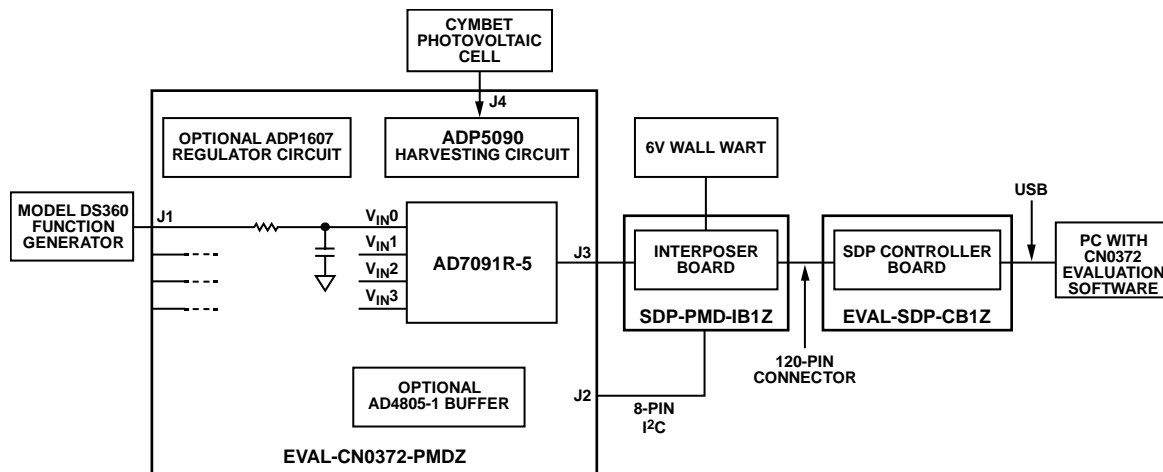

Figure 11. Test Setup Block Diagram

13582-011

Power Supply Configuration

Connect a low power, high impedance dc source (such as the Cymbet CBC-PV-01 PV cell or TEG) to the J4 terminal, and place SL4 and SL5 in Position A before opening the evaluation software. This makes use of the [ADP5090](#) energy harvesting circuit as system supply. For the complete power supply options available, see Table 4 and Table 5.

Table 6 contains the complete description of all solder links on the [EVAL-CN0372-PMDZ](#).

Table 6. Link Options

Link	Default	Description
SL1	A	This link is used in conjunction with SL7 connected A to center. A to center connects the ADP5090 BACK_UP pin to the CR2302 battery. B to center connects the ADP5090 B_CHRG pin to R36 near the super capacitor.
SL2	A	This link selects the ADP5090 DIS_SW pin connection. A to center connects the ADP5090 DIS_SW pin to ground. B to center connects the ADP5090 DIS_SW pin to PMOD_GPIO1 (Pin 9 of J3).
SL3	A	This link selects the V_{DRIVE} connection in conjunction with SL4. A to center connects the ADP5090 SYS pin to V_{DRIVE} . B to center connects the ADP1607 V_{OUT} pin to V_{DRIVE} .
SL4	A	This link selects the V_{DRIVE} source. A to center connects VDD_PMOD to V_{DRIVE} . B to center connects V_{DRIVE} to either the ADP1607 or ADP5090 output through SL3.
SL5	A	This link selects the V_{DD} source. A to center connects the ADP5090 SYS output to V_{DD} . B to center connects the ADP1607 output to V_{DD} .
SL6	open	This link selects the VDD_PMOD source when SDP-I-PMOD is not used. A to center connects the ADP5090 SYS output to VDD_PMOD . B to center connects the ADP1607 output to VDD_PMOD .
SL7	A	This link selects the CR2032 battery path. A to center connects the battery to SL1 to serve as backup (SL1 connected A to center) or to charge the super capacitor (SL1 connected B to center). B to center connects the battery to the ADP1607 V_{IN} pin.
SL8	B	This link is used to select the ADP1607 EN pin connection. A to center connects EN to GND, and turns synchronous boost off. B to center connects EN to the ADP1607 V_{IN} pin, and turns synchronous boost on.
SL9	B	This link selects the MUX_{OUT} connection. A to center connects MUX_{OUT} to the ADA4805-1 inverting input. B to center connects MUX_{OUT} to the ADA4805-1 noninverting input if SL12 is in Position B.
SL10	A	This link selects the AS_0 connection. A to center connects AS_0 to GND. B to center connects AS_0 to V_{DRIVE} .
SL11	A	This link selects the AS_1 connection. A to center connects AS_1 to GND. B to center connects AS_1 to V_{DRIVE} .
SL12	B	This link selects the optional buffer. A to center connects REF to the ADA4805-1 noninverting input. B to center connects MUX_{OUT} to the ADA4805-1 noninverting input if SL9 is in Position B.
SL13	A	This link selects the ADA4805-1 SHUTDOWN connection. A to center connects SHUTDOWN to PMOD_GPIO1. B to center connects SHUTDOWN to the V_{DD} source selected in SL5.

Table 4. V_{DD} Options

V_{DD}	Solder Link Position	
	SL5	SL7
ADP5090 SYS	A	A
ADP1607 V_{OUT}	B	B

Table 5. V_{DRIVE} Options

V_{DRIVE}	Solder Link Position	
	SL3	SL4
ADP5090 SYS	A	B
ADP1607 V_{OUT}	B	B
VDD_PMOD	No connect	A

Setup and Test

After the board is powered up and the evaluation software is initialized, set the ADC to convert at the desired channel. Introduce an input signal at the J1 terminal, click **Single Capture** or **Continuous Capture**, and observe the results.

To test the alert function, set **Low Limit** or **High Limit** in the evaluation software **Configure** tab and observe the LED alert indicator outside of the set range.

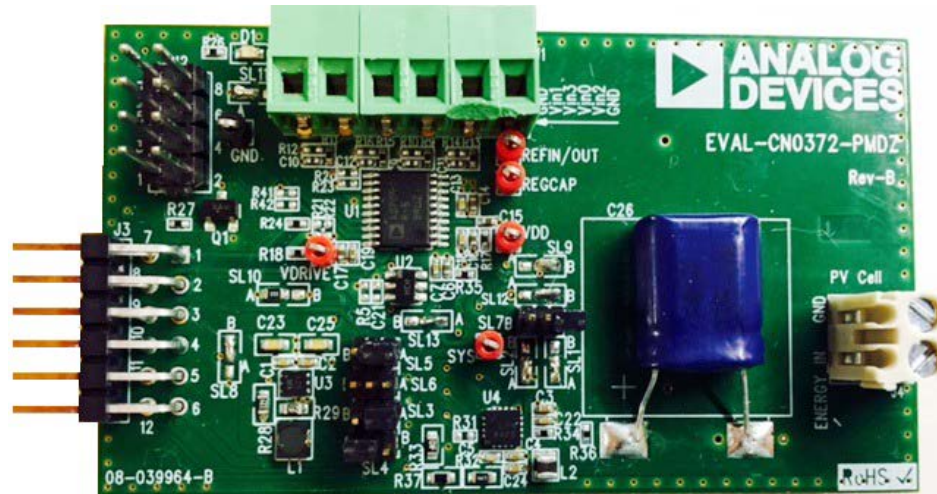

Figure 12. EVAL-CN0372-PMDZ PCB Photograph

LEARN MORE

CN-0372 Design Support Package:

www.analog.com/CN0372-DesignSupport

SDP User Guide, UG-277

AN-931 Application Note. *Understanding PulSAR ADC Support Circuitry*. Analog Devices.

Walsh, Alan. *Front-End Amplifier and RC Filter Design for a Precision SAR Analog-to-Digital Converter*. Analog Dialogue Vol. 46, No. 4. Analog Devices.

Data Sheets and Evaluation Boards

[AD7091R-5 Data Sheet](#)

[ADP5090 Data Sheet](#)

[ADA4805-1 Data Sheet](#)

[ADP1607 Data Sheet](#)

REVISION HISTORY

9/15—Revision 0: Initial Version

I²C refers to a communications protocol originally developed by Philips Semiconductors (now NXP Semiconductors).

(Continued from first page) Circuits from the Lab reference designs are intended only for use with Analog Devices products and are the intellectual property of Analog Devices or its licensors. While you may use the Circuits from the Lab reference designs in the design of your product, no other license is granted by implication or otherwise under any patents or other intellectual property by application or use of the Circuits from the Lab reference designs. Information furnished by Analog Devices is believed to be accurate and reliable. However, Circuits from the Lab reference designs are supplied "as is" and without warranties of any kind, express, implied, or statutory including, but not limited to, any implied warranty of merchantability, noninfringement or fitness for a particular purpose and no responsibility is assumed by Analog Devices for their use, nor for any infringements of patents or other rights of third parties that may result from their use. Analog Devices reserves the right to change any Circuits from the Lab reference designs at any time without notice but is under no obligation to do so.

©2015 Analog Devices, Inc. All rights reserved. Trademarks and registered trademarks are the property of their respective owners.
CN13582-0-9/15(0)



Компания «Океан Электроники» предлагает заключение долгосрочных отношений при поставках импортных электронных компонентов на взаимовыгодных условиях!

Наши преимущества:

- Поставка оригинальных импортных электронных компонентов напрямую с производств Америки, Европы и Азии, а так же с крупнейших складов мира;
- Широкая линейка поставок активных и пассивных импортных электронных компонентов (более 30 млн. наименований);
- Поставка сложных, дефицитных, либо снятых с производства позиций;
- Оперативные сроки поставки под заказ (от 5 рабочих дней);
- Экспресс доставка в любую точку России;
- Помощь Конструкторского Отдела и консультации квалифицированных инженеров;
- Техническая поддержка проекта, помощь в подборе аналогов, поставка прототипов;
- Поставка электронных компонентов под контролем ВП;
- Система менеджмента качества сертифицирована по Международному стандарту ISO 9001;
- При необходимости вся продукция военного и аэрокосмического назначения проходит испытания и сертификацию в лаборатории (по согласованию с заказчиком);
- Поставка специализированных компонентов военного и аэрокосмического уровня качества (Xilinx, Altera, Analog Devices, Intersil, Interpoint, Microsemi, Actel, Aeroflex, Peregrine, VPT, Syfer, Eurofarad, Texas Instruments, MS Kennedy, Miteq, Cobham, E2V, MA-COM, Hittite, Mini-Circuits, General Dynamics и др.);

Компания «Океан Электроники» является официальным дистрибьютором и эксклюзивным представителем в России одного из крупнейших производителей разъемов военного и аэрокосмического назначения «JONHON», а так же официальным дистрибьютором и эксклюзивным представителем в России производителя высокотехнологичных и надежных решений для передачи СВЧ сигналов «FORSTAR».



JONHON

«JONHON» (основан в 1970 г.)

Разъемы специального, военного и аэрокосмического назначения:

(Применяются в военной, авиационной, аэрокосмической, морской, железнодорожной, горно- и нефтедобывающей отраслях промышленности)

«FORSTAR» (основан в 1998 г.)

ВЧ соединители, коаксиальные кабели, кабельные сборки и микроволновые компоненты:

(Применяются в телекоммуникациях гражданского и специального назначения, в средствах связи, РЛС, а так же военной, авиационной и аэрокосмической отраслях промышленности).



Телефон: 8 (812) 309-75-97 (многоканальный)

Факс: 8 (812) 320-03-32

Электронная почта: ocean@oceanchips.ru

Web: <http://oceanchips.ru/>

Адрес: 198099, г. Санкт-Петербург, ул. Калинина, д. 2, корп. 4, лит. А