

| PART NUMBER DATA | | | | | | | | | |
|------------------|-------|-------|-------|--------|--------|--------|------|-------|--|
| CIRCUITS | A IN | mm | B IN | mm | C IN | mm | D IN | mm | |
| 2 | 1.58 | 40.2 | .375 | 9.52 | 1.125 | 28.58 | .83 | 21.1 | |
| 3 | 1.96 | 49.7 | .750 | 19.05 | 1.500 | 38.10 | 1.21 | 30.7 | |
| 4 | 2.33 | 59.2 | 1.125 | 28.58 | 1.875 | 47.63 | 1.58 | 40.2 | |
| 5 | 2.71 | 68.7 | 1.500 | 38.10 | 2.250 | 57.15 | 1.96 | 49.7 | |
| 6 | 3.08 | 78.3 | 1.875 | 47.63 | 2.625 | 66.68 | 2.33 | 59.2 | |
| 7 | 3.46 | 87.8 | 2.250 | 57.15 | 3.000 | 76.20 | 2.71 | 68.8 | |
| 8 | 3.83 | 97.3 | 2.625 | 66.68 | 3.375 | 85.73 | 3.08 | 78.3 | |
| 9 | 4.21 | 106.8 | 3.000 | 76.20 | 3.750 | 95.25 | 3.46 | 87.8 | |
| 10 | 4.58 | 116.4 | 3.375 | 85.73 | 4.125 | 104.78 | 3.83 | 97.3 | |
| 11 | 4.96 | 125.9 | 3.750 | 95.25 | 4.500 | 114.30 | 4.21 | 106.9 | |
| 12 | 5.33 | 135.4 | 4.125 | 104.78 | 4.875 | 123.83 | 4.58 | 116.4 | |
| 13 | 5.71 | 144.9 | 4.500 | 114.30 | 5.250 | 133.35 | 4.96 | 125.9 | |
| 14 | 6.08 | 154.5 | 4.875 | 123.83 | 5.625 | 142.88 | 5.33 | 135.4 | |
| 15 | 6.46 | 164.0 | 5.250 | 133.35 | 6.000 | 152.40 | 5.71 | 145.0 | |
| 16 | 6.83 | 173.5 | 5.625 | 142.88 | 6.375 | 161.93 | 6.08 | 154.5 | |
| 17 | 7.21 | 183.0 | 6.000 | 152.40 | 6.750 | 171.45 | 6.46 | 164.0 | |
| 18 | 7.58 | 192.6 | 6.375 | 161.93 | 7.125 | 180.98 | 6.83 | 173.5 | |
| 19 | 7.96 | 202.1 | 6.750 | 171.45 | 7.500 | 190.50 | 7.21 | 183.1 | |
| 20 | 8.33 | 211.6 | 7.125 | 180.98 | 7.875 | 200.03 | 7.58 | 192.6 | |
| 21 | 8.71 | 221.1 | 7.500 | 190.50 | 8.250 | 209.55 | 7.96 | 202.1 | |
| 22 | 9.08 | 230.7 | 7.875 | 200.03 | 8.625 | 219.08 | 8.33 | 211.6 | |
| 23 | 9.46 | 240.2 | 8.250 | 209.55 | 9.000 | 228.60 | 8.71 | 221.2 | |
| 24 | 9.83 | 249.7 | 8.625 | 219.08 | 9.375 | 238.13 | 9.08 | 230.7 | |
| 25 | 10.21 | 259.2 | 9.000 | 228.60 | 9.750 | 247.65 | 9.46 | 240.2 | |
| 26 | 10.58 | 268.8 | 9.375 | 238.13 | 10.125 | 257.18 | 9.83 | 249.7 | |

PART NUMBER LEGEND

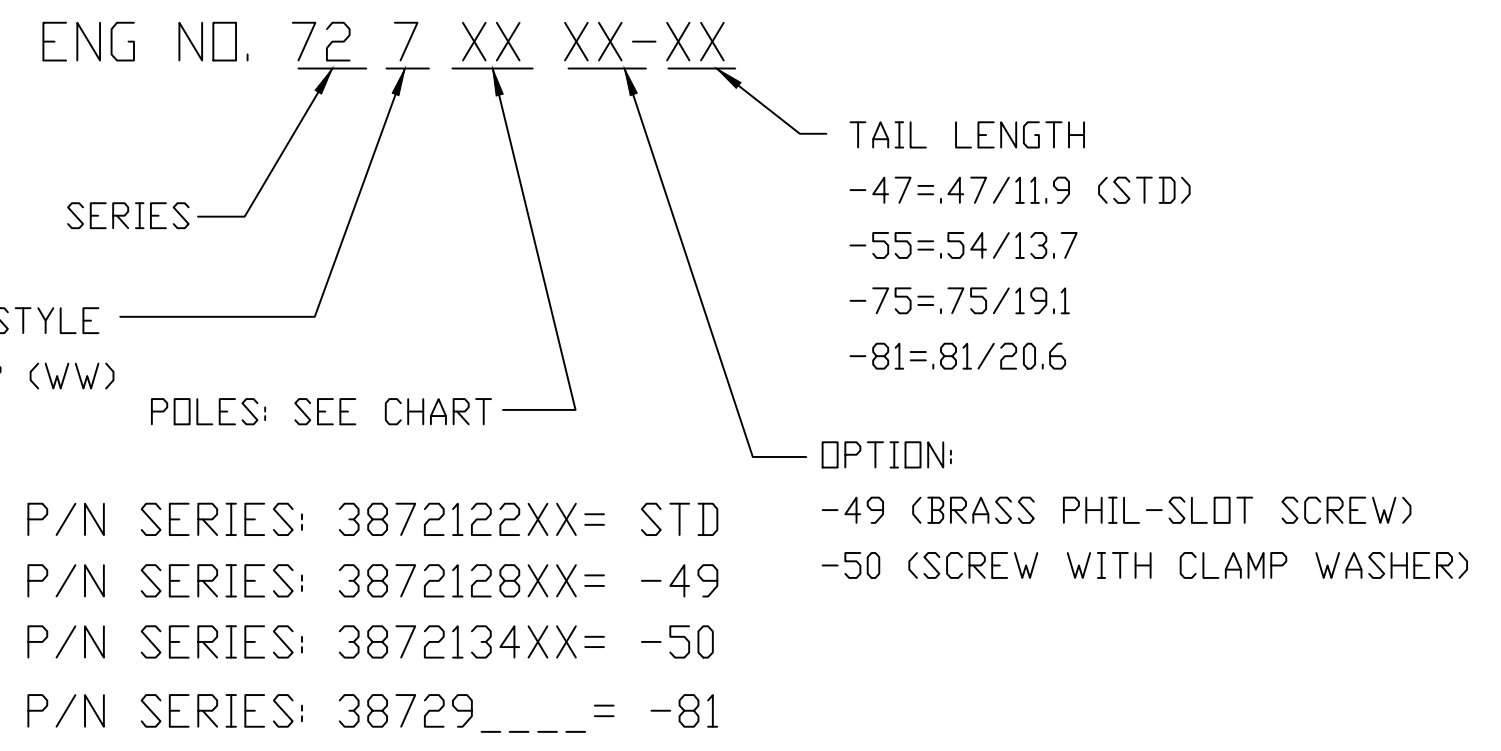

- NOTES:
- MATERIAL: SEE TABLE
 - ASSEMBLY MUST MEET BEAU WORKMANSHIP STANDARD ES-19900-059
 - PRODUCT SPECIFICATION: PS-38710-001
 - SEE SAP BOM FOR COMPONENT PART NUMBERS
 - "XX" REFERS TO THE QUANTITY OF CIRCUITS

| ITEM | QTY | DESCRIPTION | MATERIAL NO. | ENGINEERING NO. |
|------|-----|-------------------------------------|--------------|-----------------|
| 6 | XX | #6-32 PH/SLOTTED SCREW (OPTION -50) | 380010099 | 2504-9201-C220 |
| 5 | XX | #6-32 PH/SLOTTED SCREW (OPTION -49) | 380010058 | 1804-9101-A120 |
| 4 | XX | #6-32 PH/SLOTTED SCREW (STD) | 380010092 | 2504-9101-C220 |
| 3 | 2 | MOUNTING PLATE | 380021308 | 7204-7201-A120 |
| 2 | XX | TERMINAL | 380021279 | 7204-3411-A260 |
| 1 | 1 | BARRIER TERMINAL STRIP | 38728_____ | 7200-XX02-V000 |

RELEASED
 EC NO: IPG2015-0118
 DRWN: RSTONE 2014/07/18
 CHKD: BARDEN 2014/07/23
 APPR: JFMURPHY 2014/08/02

QUALITY SYMBOL
 ▽=0
 ▽=0

GENERAL TOLERANCES (UNLESS SPECIFIED)

| | mm | INCH |
|----------|-------|-------|
| 4 PLACES | ±--- | ±--- |
| 3 PLACES | ±--- | ±.005 |
| 2 PLACES | ±0.13 | ±.01 |
| 1 PLACE | ±0.3 | ±--- |

ANGULAR ±---°

DRAFT WHERE APPLICABLE MUST REMAIN WITHIN DIMENSIONS

DIMENSION STYLE IN/MM

SCALE ---

DESIGN UNITS INCH

THIRD ANGLE PROJECTION

DRAWN BY RSTONE DATE 2014/07/18

CHECKED BY DATE

APPROVED BY JFMURPHY DATE 2014/08/02

MATERIAL NO. SEE PART LEGEND

DOCUMENT NO. E-38721-010

SHEET NO. 1 OF 1

THIS DRAWING CONTAINS INFORMATION THAT IS PROPRIETARY TO MOLEX INCORPORATED AND SHOULD NOT BE USED WITHOUT WRITTEN PERMISSION

REF. THIS DRAWING SUPERSEDES E-78721-003 REV-B

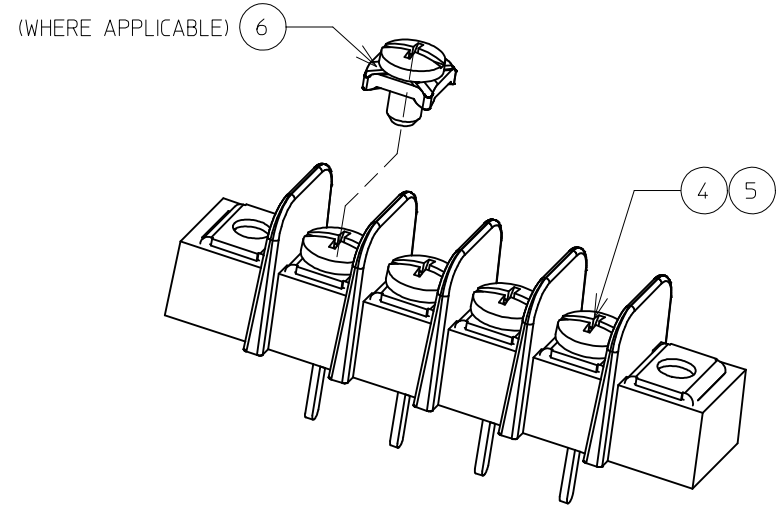
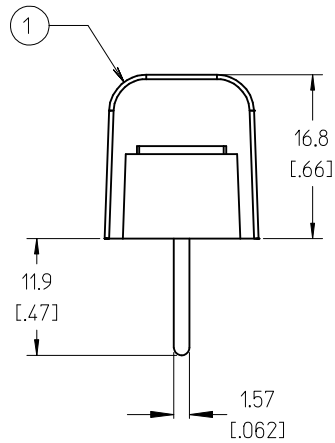
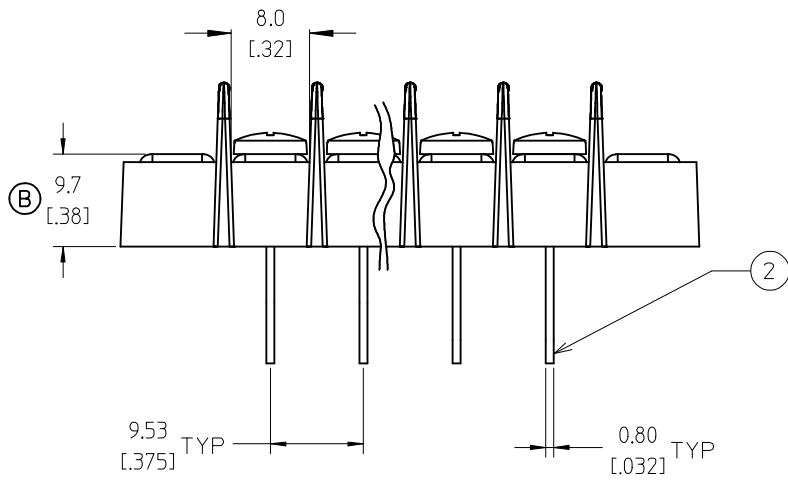
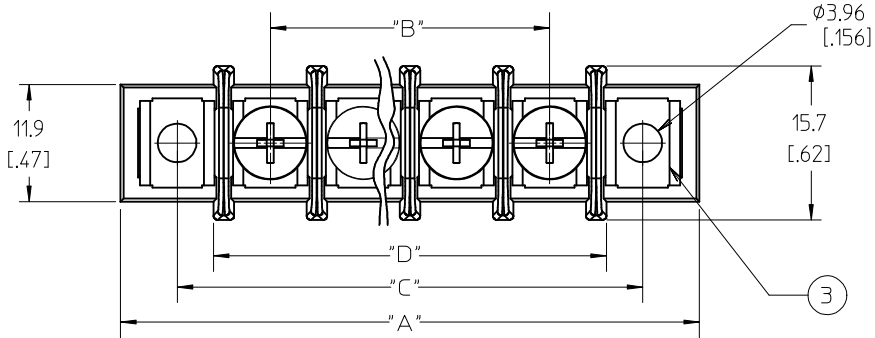

NOTES:

1. MATERIAL: SEE TABLE
2. FINISHES: SEE TABLE
3. PRODUCT SPECIFICATION: NOT REQUIRED
4. PACKAGING: NOT REQUIRED
5. MATES WITH: NONE
6. *XX* REFERS TO THE QUANTITY OF CIRCUITS.
7. ALL COMPONENTS ARE ROHS COMPLIANT.

| ITEM | QTY | DESCRIPTION | MATERIAL | FINISH |
|------|-----|-------------------------------------|----------|--------------------|
| 6 | XX | #6-32 PH/SLOTTED SCREW (OPTION -50) | STEEL | ZN, CLEAR CHROMATE |
| 5 | XX | #6-32 PH/SLOTTED SCREW (OPTION -49) | BRASS | NICKEL PLATE |
| 4 | XX | #6-32 PH/SLOTTED SCREW (STD) | STEEL | ZN, CLEAR CHROMATE |
| 3 | 2 | MOUNTING PLATE | BRASS | NICKEL PLATE |
| 2 | XX | TERMINAL | BRASS | TIN PLATE |
| 1 | 1 | BARRIER TERMINAL STRIP | PBT | BLACK |

| |
|----------------------------|
| UPDATE TERM. HEIGHT DIM. |
| EC NO: WNAZ009-0445 |
| DRWN: JENC INAS 2009/07/01 |
| CHKD: CYORK 2009/07/02 |
| APPR: JMACNE IL 2009/07/02 |
| B |

| |
|-----------------|
| QUALITY SYMBOLS |
| ▽=0 |
| ▽=0 |
| DESCRIPTION |
| REV |

| |
|--|
| GENERAL TOLERANCES (UNLESS SPECIFIED) |
| mm INCH |
| 4 PLACES ± --- ± --- |
| 3 PLACES ± --- ± .005 |
| 2 PLACES ± 0.13 ± .01 |
| 1 PLACE ± 0.3 ± --- |
| ANGULAR ± 2 ° |
| DRAFT WHERE APPLICABLE MUST REMAIN WITHIN DIMENSIONS |

| | |
|-----------------|------------|
| DIMENSION STYLE | MM/IN |
| DRAWN BY | DATE |
| C. YORK | 2006/03/24 |
| CHECKED BY | DATE |
| RDEROSS | 2006/03/24 |
| APPROVED BY | DATE |
| RDEROSS | 2006/03/24 |
| MATERIAL NO. | SEE CHART |
| SIZE | B |

| | |
|---|---|
| SCALE | 2:1 |
| DESIGN UNITS | INCH |
| THIRD ANGLE PROJECTION | |
| TITLE | SR BTS, WW, ASSY 9.53 MM [0.375] CENTERS |
| MATERIAL NO. | SEE CHART |
| DOCUMENT NO. | SD-38721-003 |
| SHEET NO. | 1 OF 2 |
| THIS DRAWING CONTAINS INFORMATION THAT IS PROPRIETARY TO MOLEX INCORPORATED AND SHOULD NOT BE USED WITHOUT WRITTEN PERMISSION | |

| NUMBER OF CIRCUITS "XX" | DIM. "A" | | DIM. "B" | | DIM. "C" | | DIM. "D" | |
|-------------------------|----------|---------|----------|---------|----------|---------|----------|--------|
| 02 | 40.1 | [.58] | 9.53 | [.375] | 28.6 | [1.13] | 21.1 | [.83] |
| 03 | 49.7 | [1.96] | 19.05 | [.750] | 38.1 | [1.50] | 30.6 | [1.21] |
| 04 | 59.2 | [2.33] | 28.58 | [1.125] | 47.6 | [1.88] | 40.1 | [1.58] |
| 05 | 68.7 | [2.71] | 38.10 | [1.500] | 57.2 | [2.25] | 49.7 | [1.96] |
| 06 | 78.2 | [3.08] | 47.63 | [1.875] | 66.7 | [2.63] | 59.2 | [2.33] |
| 07 | 87.8 | [3.46] | 57.15 | [2.250] | 76.2 | [3.00] | 68.7 | [2.71] |
| 08 | 97.3 | [3.83] | 66.68 | [2.625] | 85.7 | [3.38] | 78.2 | [3.08] |
| 09 | 106.8 | [4.21] | 76.20 | [3.000] | 95.3 | [3.75] | 87.8 | [3.46] |
| 10 | 116.3 | [4.58] | 85.73 | [3.375] | 104.8 | [4.13] | 97.3 | [3.83] |
| 11 | 125.9 | [4.96] | 95.25 | [3.750] | 114.3 | [4.50] | 106.8 | [4.21] |
| 12 | 135.4 | [5.33] | 104.78 | [4.125] | 123.8 | [4.88] | 116.3 | [4.58] |
| 13 | 144.9 | [5.71] | 114.30 | [4.500] | 133.4 | [5.25] | 125.9 | [4.96] |
| 14 | 154.4 | [6.08] | 123.83 | [4.875] | 142.9 | [5.63] | 135.4 | [5.33] |
| 15 | 164.0 | [6.46] | 133.35 | [5.250] | 152.4 | [6.00] | 144.9 | [5.71] |
| 16 | 173.5 | [6.83] | 142.88 | [5.625] | 161.9 | [6.38] | 154.4 | [6.08] |
| 17 | 183.0 | [7.21] | 152.40 | [6.000] | 171.5 | [6.75] | 164.0 | [6.46] |
| 18 | 192.5 | [7.58] | 161.93 | [6.375] | 181.0 | [7.13] | 173.5 | [7.21] |
| 19 | 202.1 | [7.96] | 171.45 | [6.750] | 190.5 | [7.50] | 192.5 | [7.58] |
| 20 | 211.6 | [8.33] | 180.98 | [7.125] | 200.0 | [7.88] | 202.1 | [7.96] |
| 21 | 221.1 | [8.71] | 190.50 | [7.500] | 209.6 | [8.25] | 211.6 | [8.33] |
| 22 | 230.6 | [9.08] | 200.03 | [7.875] | 219.1 | [8.63] | 221.1 | [8.71] |
| 23 | 240.2 | [9.46] | 209.55 | [8.250] | 228.6 | [9.00] | 230.6 | [9.08] |
| 24 | 249.7 | [9.83] | 219.08 | [8.625] | 238.1 | [9.38] | 230.6 | [9.08] |
| 25 | 259.2 | [10.21] | 228.60 | [9.000] | 247.7 | [9.75] | 240.2 | [9.46] |
| 26 | 268.7 | [10.58] | 238.13 | [9.375] | 257.2 | [10.13] | 249.7 | [9.83] |

| MATERIAL NO. (OPTION -50) | MATERIAL NO. (OPTION -49) | MATERIAL NO. (STANDARD) | NUMBER OF CIRCUITS "XX" |
|---------------------------|---------------------------|-------------------------|-------------------------|
| 38721-3402 | 38721-2802 | 38721-2202 | 02 |
| 38721-3403 | 38721-2803 | 38721-2203 | 03 |
| 38721-3404 | 38721-2804 | 38721-2204 | 04 |
| 38721-3405 | 38721-2805 | 38721-2205 | 05 |
| 38721-3406 | 38721-2806 | 38721-2206 | 06 |
| 38721-3407 | 38721-2807 | 38721-2207 | 07 |
| 38721-3408 | 38721-2808 | 38721-2208 | 08 |
| 38721-3409 | 38721-2809 | 38721-2209 | 09 |
| 38721-3410 | 38721-2810 | 38721-2210 | 10 |
| 38721-3411 | 38721-2811 | 38721-2211 | 11 |
| 38721-3412 | 38721-2812 | 38721-2212 | 12 |
| 38721-3413 | 38721-2813 | 38721-2213 | 13 |
| 38721-3414 | 38721-2814 | 38721-2214 | 14 |
| 38721-3415 | 38721-2815 | 38721-2215 | 15 |
| 38721-3416 | 38721-2816 | 38721-2216 | 16 |
| 38721-3417 | 38721-2817 | 38721-2217 | 17 |
| 38721-3418 | 38721-2818 | 38721-2218 | 18 |
| 38721-3419 | 38721-2819 | 38721-2219 | 19 |
| 38721-3420 | 38721-2820 | 38721-2220 | 20 |
| 38721-3421 | 38721-2821 | 38721-2221 | 21 |
| 38721-3422 | 38721-2822 | 38721-2222 | 22 |
| 38721-3423 | 38721-2823 | 38721-2223 | 23 |
| 38721-3424 | 38721-2824 | 38721-2224 | 24 |
| 38721-3425 | 38721-2825 | 38721-2225 | 25 |
| 38721-3426 | 38721-2826 | 38721-2226 | 26 |

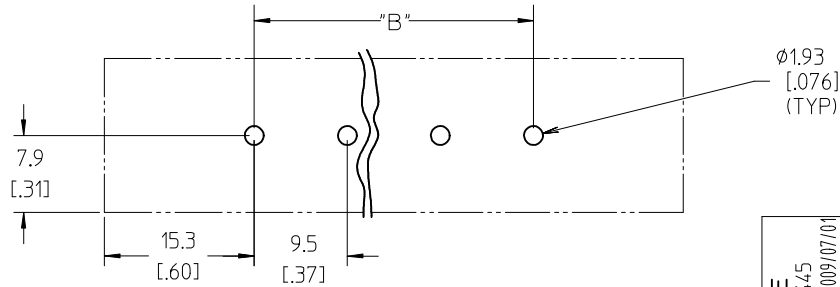

| SEE SHEET ONE EC NO: WNA2009-0445 DRWN: JENC INAS 2009/07/01 CHKD: CYORK 2009/07/02 APPR: JMACNE IL 2009/07/02 | QUALITY SYMBOLS ▽=0 ▽=0 | GENERAL TOLERANCES (UNLESS SPECIFIED) <table border="1"> <tr><th colspan="2">mm</th><th colspan="2">INCH</th></tr> <tr><td>4 PLACES</td><td>± ---</td><td>± ---</td><td></td></tr> <tr><td>3 PLACES</td><td>± ---</td><td>± .005</td><td></td></tr> <tr><td>2 PLACES</td><td>± 0.13</td><td>± .01</td><td></td></tr> <tr><td>1 PLACE</td><td>± 0.3</td><td>± ---</td><td></td></tr> </table> | mm | | INCH | | 4 PLACES | ± --- | ± --- | | 3 PLACES | ± --- | ± .005 | | 2 PLACES | ± 0.13 | ± .01 | | 1 PLACE | ± 0.3 | ± --- | | DIMENSION STYLE MM/IN | SCALE 2:1 | DESIGN UNITS INCH | THIRD ANGLE PROJECTION |
|---|---|---|--|--|------|--|----------|-------|-------|--|----------|-------|--------|--|----------|--------|-------|--|---------|-------|-------|--|---------------------------------|---------------------|-----------------------------|------------------------|
| | mm | | INCH | | | | | | | | | | | | | | | | | | | | | | | |
| | 4 PLACES | ± --- | ± --- | | | | | | | | | | | | | | | | | | | | | | | |
| | 3 PLACES | ± --- | ± .005 | | | | | | | | | | | | | | | | | | | | | | | |
| 2 PLACES | ± 0.13 | ± .01 | | | | | | | | | | | | | | | | | | | | | | | | |
| 1 PLACE | ± 0.3 | ± --- | | | | | | | | | | | | | | | | | | | | | | | | |
| DRAFT WHERE APPLICABLE MUST REMAIN WITHIN DIMENSIONS | DRAWN BY C. YORK | DATE 2006/03/24 | TITLE SR BTS, WW, ASSY 9.53 MM [.375] CENTERS | | | | | | | | | | | | | | | | | | | | | | | |
| MATERIAL NO. | APPROVED BY RDEROSS | DATE 2006/03/24 | DOCUMENT NO. SD-38721-003 | | | | | | | | | | | | | | | | | | | | | | | |
| SIZE B | THIS DRAWING CONTAINS INFORMATION THAT IS PROPRIETARY TO MOLEX INCORPORATED AND SHOULD NOT BE USED WITHOUT WRITTEN PERMISSION | | | | | | | | | | | | | | | | | | | | | | | | | |

ISO VIEW
4 CIRCUIT SHOWN

PART NUMBER DATA

| CIRCUITS | A IN | | B IN | | C IN | | D IN | |
|----------|-------|-------|-------|--------|--------|--------|------|-------|
| | mm | mm | mm | mm | mm | mm | mm | mm |
| 2 | 1.58 | 40.2 | .375 | 9.52 | 1.125 | 28.58 | .83 | 21.1 |
| 3 | 1.96 | 49.7 | .750 | 19.05 | 1.500 | 38.10 | 1.21 | 30.7 |
| 4 | 2.33 | 59.2 | 1.125 | 28.58 | 1.875 | 47.63 | 1.58 | 40.2 |
| 5 | 2.71 | 68.7 | 1.500 | 38.10 | 2.250 | 57.15 | 1.96 | 49.7 |
| 6 | 3.08 | 78.3 | 1.875 | 47.63 | 2.625 | 66.68 | 2.33 | 59.2 |
| 7 | 3.46 | 87.8 | 2.250 | 57.15 | 3.000 | 76.20 | 2.71 | 68.8 |
| 8 | 3.83 | 97.3 | 2.625 | 66.68 | 3.375 | 85.73 | 3.08 | 78.3 |
| 9 | 4.21 | 106.8 | 3.000 | 76.20 | 3.750 | 95.25 | 3.46 | 87.8 |
| 10 | 4.58 | 116.4 | 3.375 | 85.73 | 4.125 | 104.78 | 3.83 | 97.3 |
| 11 | 4.96 | 125.9 | 3.750 | 95.25 | 4.500 | 114.30 | 4.21 | 106.9 |
| 12 | 5.33 | 135.4 | 4.125 | 104.78 | 4.875 | 123.83 | 4.58 | 116.4 |
| 13 | 5.71 | 144.9 | 4.500 | 114.30 | 5.250 | 133.35 | 4.96 | 125.9 |
| 14 | 6.08 | 154.5 | 4.875 | 123.83 | 5.625 | 142.88 | 5.33 | 135.4 |
| 15 | 6.46 | 164.0 | 5.250 | 133.35 | 6.000 | 152.40 | 5.71 | 145.0 |
| 16 | 6.83 | 173.5 | 5.625 | 142.88 | 6.375 | 161.93 | 6.08 | 154.5 |
| 17 | 7.21 | 183.0 | 6.000 | 152.40 | 6.750 | 171.45 | 6.46 | 164.0 |
| 18 | 7.58 | 192.6 | 6.375 | 161.93 | 7.125 | 180.98 | 6.83 | 173.5 |
| 19 | 7.96 | 202.1 | 6.750 | 171.45 | 7.500 | 190.50 | 7.21 | 183.1 |
| 20 | 8.33 | 211.6 | 7.125 | 180.98 | 7.875 | 200.03 | 7.58 | 192.6 |
| 21 | 8.71 | 221.1 | 7.500 | 190.50 | 8.250 | 209.55 | 7.96 | 202.1 |
| 22 | 9.08 | 230.7 | 7.875 | 200.03 | 8.625 | 219.08 | 8.33 | 211.6 |
| 23 | 9.46 | 240.2 | 8.250 | 209.55 | 9.000 | 228.60 | 8.71 | 221.2 |
| 24 | 9.83 | 249.7 | 8.625 | 219.08 | 9.375 | 238.13 | 9.08 | 230.7 |
| 25 | 10.21 | 259.2 | 9.000 | 228.60 | 9.750 | 247.65 | 9.46 | 240.2 |
| 26 | 10.58 | 268.8 | 9.375 | 238.13 | 10.125 | 257.18 | 9.83 | 249.7 |

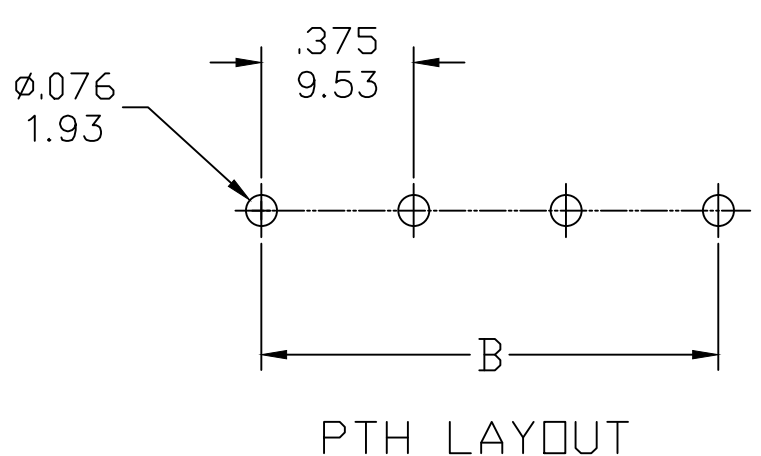
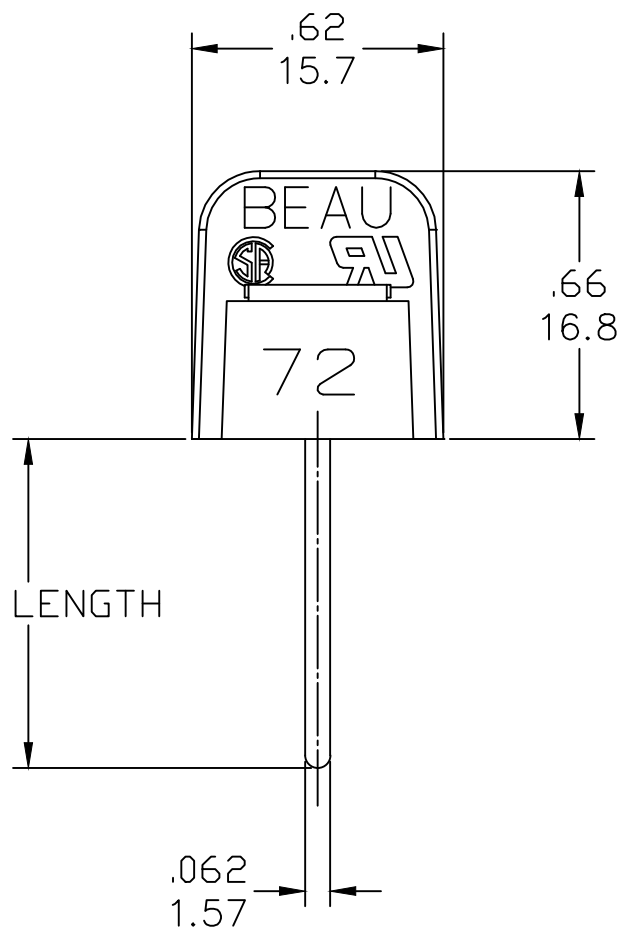
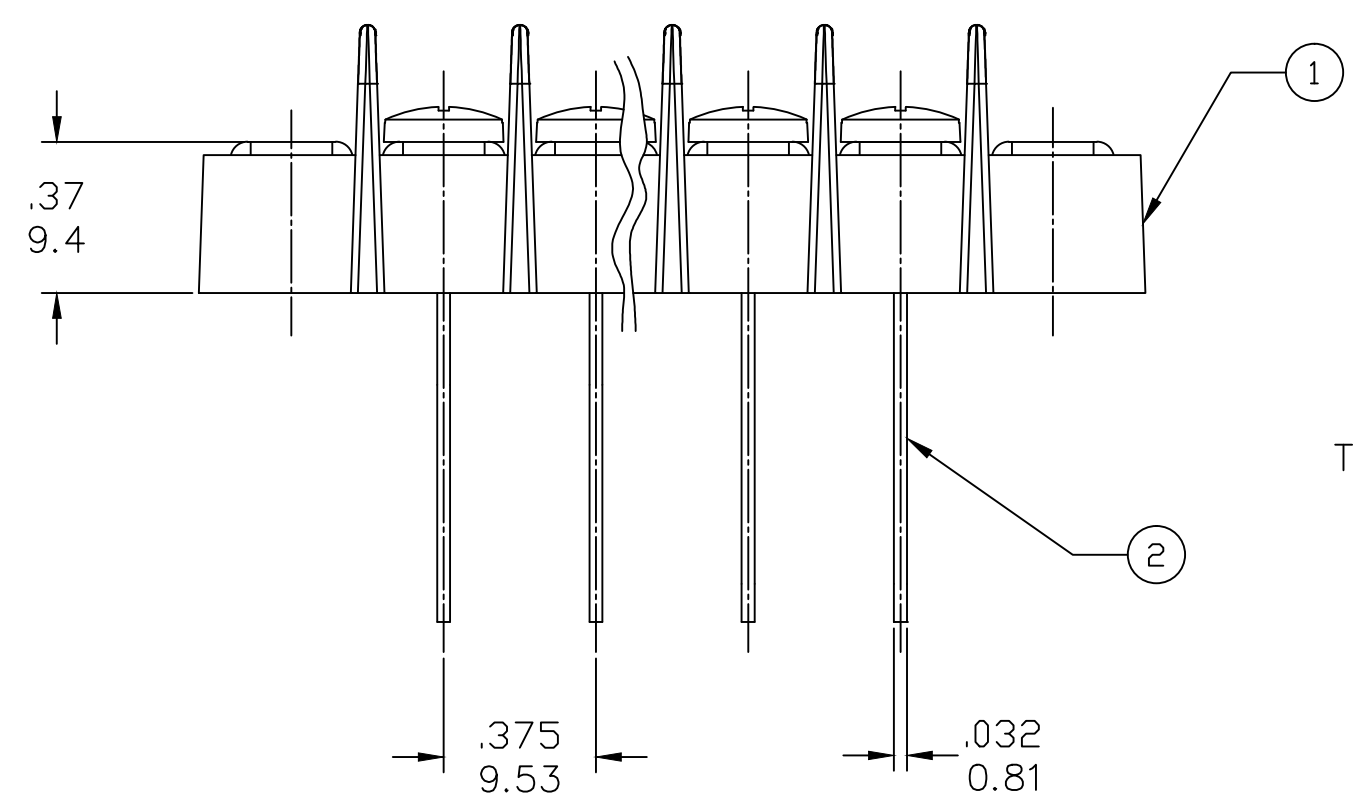
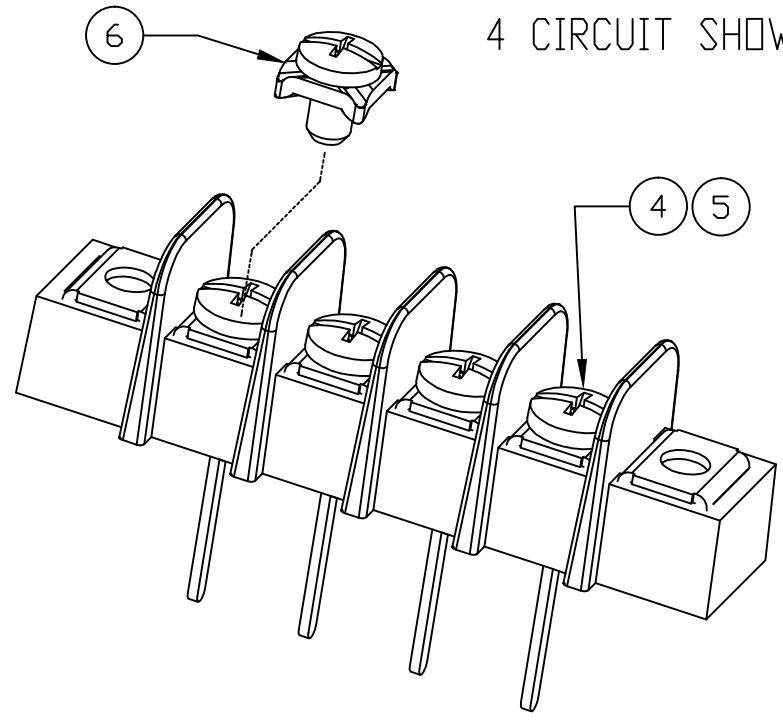
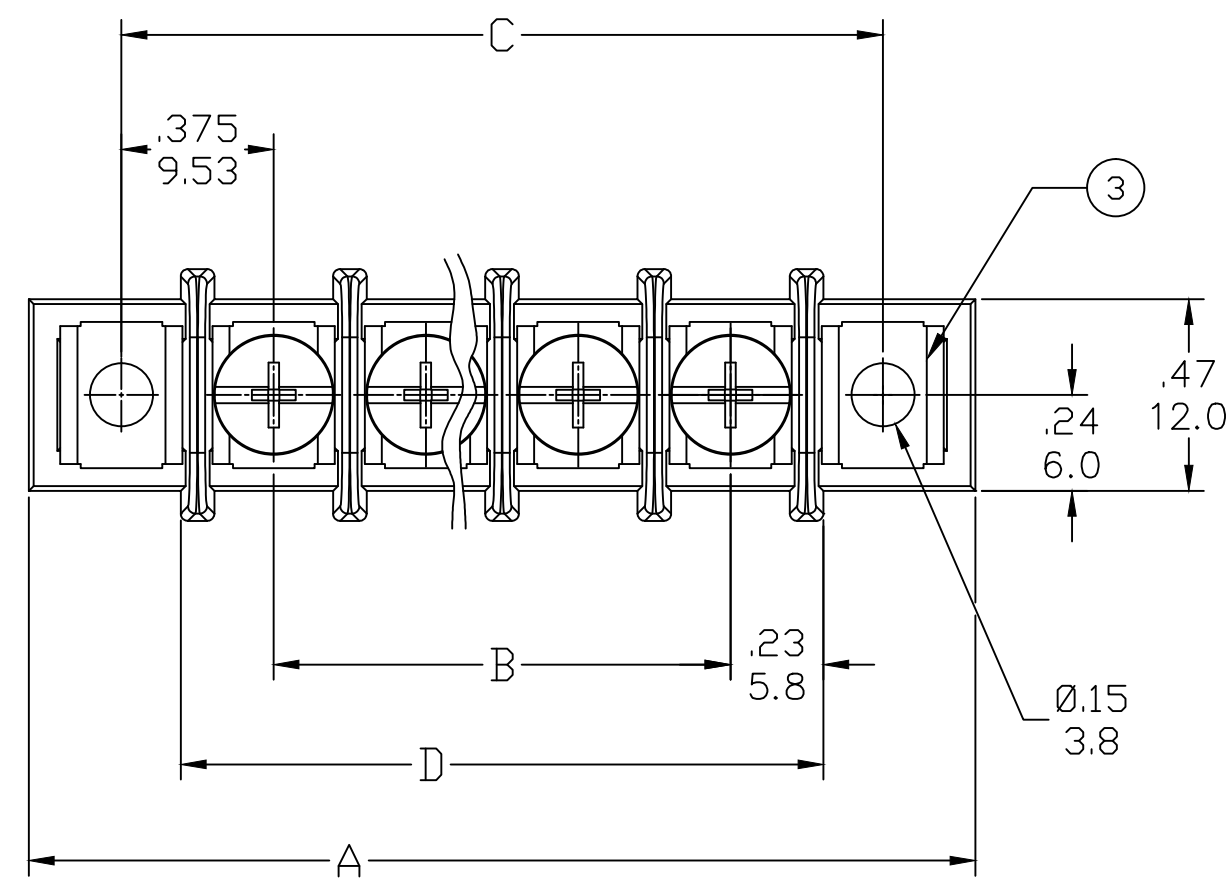

- NOTES:
- MATERIAL: SEE TABLE
 - FINISHES: SEE TABLE
 - PRODUCT SPECIFICATION: PS-38710-001
 - "XX" REFERS TO THE QUANTITY OF CIRCUITS
 - DIMS SHOWN ARE FOR REFERENCE ONLY

PART NUMBER LEGEND

ENG NO. 72 7 XX XX-XX

SERIES

TAIL LENGTH
-47=.47/11.9 (STD)
-55=.54/13.7
-75=.75/19.1
-81=.81/20.6

OPTION:
-49 (BRASS PHIL-SLOT SCREW)
-50 (SCREW WITH CLAMP WASHER)

TERMINAL STYLE
WIRE WRAP (WW)

POLES: SEE CHART

SAP P/N SERIES: 3872122XX= STD
SAP P/N SERIES: 3872128XX= -49
SAP P/N SERIES: 3872134XX= -50
SAP P/N SERIES: 38729___= -81

REF. THIS DRAWING SUPERSEDES SD-78721-003 REV-B

| ITEM | QTY | DESCRIPTION | MATERIAL | FINISH |
|------|-----|-------------------------------------|----------|--------------------|
| 6 | XX | #6-32 PH/SLOTTED SCREW (OPTION -50) | STEEL | ZN, CLEAR CHROMATE |
| 5 | XX | #6-32 PH/SLOTTED SCREW (OPTION -49) | BRASS | NICKEL PLATE |
| 4 | XX | #6-32 PH/SLOTTED SCREW (STD) | STEEL | ZN, CLEAR CHROMATE |
| 3 | 2 | MOUNTING PLATE | BRASS | NICKEL PLATE |
| 2 | XX | TERMINAL | BRASS | TIN PLATE |
| 1 | 1 | BARRIER TERMINAL STRIP | PBT | BLACK |

| | | | | | | | |
|-------------|----------------------------|--------------|------------|--------------|------------|----------------|------------|
| RELEASED | EC NO: ICG2015-0118 | DRWN: RSTONE | 2014/07/17 | CHKD: BARDEN | 2014/07/23 | APPR: JFMURPHY | 2014/08/02 |
| DESCRIPTION | QUALITY SYMBOL | | | | | | |
| | $\nabla=0$ $\nabla C=0$ | | | | | | |

| GENERAL TOLERANCES (UNLESS SPECIFIED) | | DIMENSION STYLE IN/MM | |
|--|-------|-----------------------|------|
| | | mm | INCH |
| 4 PLACES | ±--- | ±--- | ±--- |
| 3 PLACES | ±--- | ±.005 | |
| 2 PLACES | ±0.13 | ±.01 | |
| 1 PLACE | ±0.3 | ±--- | |
| ANGULAR ±--- | | | |
| DRAFT WHERE APPLICABLE MUST REMAIN WITHIN DIMENSIONS | | | |

| DRAWN BY | | DATE | |
|-----------------|---|--------------|--|
| RSTONE | | 2014/07/17 | |
| CHECKED BY | | DATE | |
| BARDEN | | | |
| APPROVED BY | | DATE | |
| JFMURPHY | | 2014/08/02 | |
| MATERIAL NO. | | DOCUMENT NO. | |
| SEE PART LEGEND | | SD-38721-010 | |
| SIZE | THIS DRAWING CONTAINS INFORMATION THAT IS PROPRIETARY TO MOLEX INCORPORATED AND SHOULD NOT BE USED WITHOUT WRITTEN PERMISSION | | |
| C | | | |

| SCALE | DESIGN UNITS | THIRD ANGLE PROJECTION | |
|---|--------------|------------------------|--------|
| --- | INCH | | |
| SR BTS WW ASSY .375 PITCH WITH MOUNTING ENDS | | | |
| MOLEX INCORPORATED | | | |
| SHEET NO. | | | 1 OF 1 |

Компания «Океан Электроники» предлагает заключение долгосрочных отношений при поставках импортных электронных компонентов на взаимовыгодных условиях!

Наши преимущества:

- Поставка оригинальных импортных электронных компонентов напрямую с производств Америки, Европы и Азии, а так же с крупнейших складов мира;
- Широкая линейка поставок активных и пассивных импортных электронных компонентов (более 30 млн. наименований);
- Поставка сложных, дефицитных, либо снятых с производства позиций;
- Оперативные сроки поставки под заказ (от 5 рабочих дней);
- Экспресс доставка в любую точку России;
- Помощь Конструкторского Отдела и консультации квалифицированных инженеров;
- Техническая поддержка проекта, помощь в подборе аналогов, поставка прототипов;
- Поставка электронных компонентов под контролем ВП;
- Система менеджмента качества сертифицирована по Международному стандарту ISO 9001;
- При необходимости вся продукция военного и аэрокосмического назначения проходит испытания и сертификацию в лаборатории (по согласованию с заказчиком);
- Поставка специализированных компонентов военного и аэрокосмического уровня качества (Xilinx, Altera, Analog Devices, Intersil, Interpoint, Microsemi, Actel, Aeroflex, Peregrine, VPT, Syfer, Eurofarad, Texas Instruments, MS Kennedy, Miteq, Cobham, E2V, MA-COM, Hittite, Mini-Circuits, General Dynamics и др.);

Компания «Океан Электроники» является официальным дистрибьютором и эксклюзивным представителем в России одного из крупнейших производителей разъемов военного и аэрокосмического назначения «JONHON», а так же официальным дистрибьютором и эксклюзивным представителем в России производителя высокотехнологичных и надежных решений для передачи СВЧ сигналов «FORSTAR».



JONHON

«JONHON» (основан в 1970 г.)

Разъемы специального, военного и аэрокосмического назначения:

(Применяются в военной, авиационной, аэрокосмической, морской, железнодорожной, горно- и нефтедобывающей отраслях промышленности)

«FORSTAR» (основан в 1998 г.)

ВЧ соединители, коаксиальные кабели, кабельные сборки и микроволновые компоненты:

(Применяются в телекоммуникациях гражданского и специального назначения, в средствах связи, РЛС, а так же военной, авиационной и аэрокосмической отраслях промышленности).



Телефон: 8 (812) 309-75-97 (многоканальный)

Факс: 8 (812) 320-03-32

Электронная почта: ocean@oceanchips.ru

Web: <http://oceanchips.ru/>

Адрес: 198099, г. Санкт-Петербург, ул. Калинина, д. 2, корп. 4, лит. А