

Specification

LC/UPC Receptacle XFP

Optical Transceiver Module

10 Gigabit Ethernet

10GBASE-SR



Ordering Information

TAS-X1XH5-BA6

Model Name	Voltage	Category	Device type	Interface	Temperature	Distance
TAS-X1XH5-BA6	5V, 3.3V, 1.8V	With DDMI	850 nm VCSEL	AC-AC / TTL	0°C ~ +70°C	300 m

Features

- **STM64 or 10GBase SR/SW application**
- **Supports Data rate 9.95 ~ 10.5 Gbps**
- **Up to 300 m transmission distance over OMA3 MMF**
- **850 nm VCSEL Laser transmitter**
- **850 nm receiver with PIN-TIA**
- **2-wire interface for integrated digital diagnostic Monitoring**
- **Operation case temperature 0~70°C for commercial**
- **Single +5V +3.3V +1.8V power supply**
- **XFP MAS package with LC/UPC receptacle optical interface**
- **RoHS-10 compliance**

Pin Assignment and Pin Description

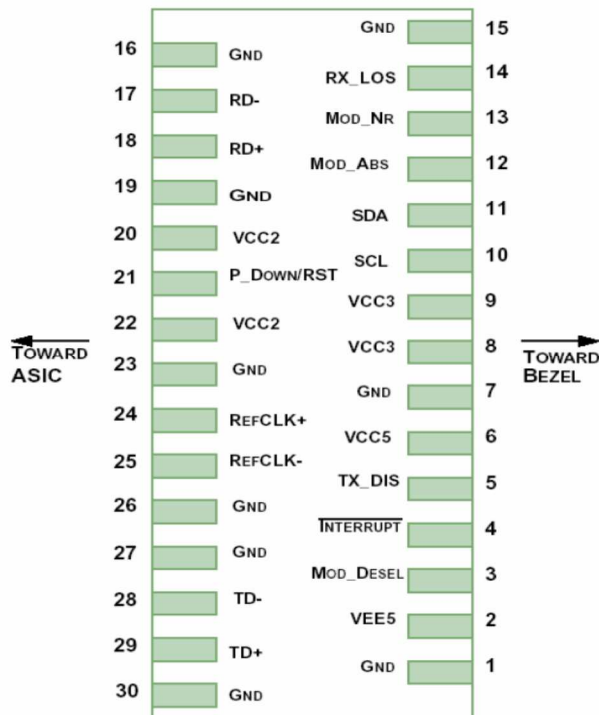

Pin Definitions

PIN	Logic	Symbol	Name/Description	Note
1		GND	Ground	1
2		VEE5	Optional -5.2V power supply, not in use	3
3	LVTLL-I	Mod_DeSel	Module Deselect; when held low allows module to respond 2-wire serial interface	
4	LVTLL-O	Interrupt	Indicates presence of an important condition which can be read over the 2-wire serial interface	2
5	LVTLL-I	TX_DIS	Transmitter Disable; turn off transmitter laser output	
6		VCC5	+5V power supply, not in use	3
7		GND	Ground	1
8		VCC3	+3.3V power supply	
9		VCC3	+3.3V power supply	
10	LVTTL-I/O	SCL	2-wire serial interface clock	2
11	LVTTL-I/O	SDA	2-wire serial interface data	2
12	LVTTL-O	Mod_Abs	Indicates module is not present. ground in the module	2

13	LVTTL-O	Mod_NR	Module not ready, indicating module operational fault	2
14	LVTTL-O	RX_LOS	Receiver loss of signal indicator	2
15		GND	Ground	1
16		GND	Ground	1
17	CML-O	RD-	Receiver Inverted Data Output	
18	CML-O	RD+	Receiver Non-Inverted Data Output	
19		GND	Ground	1
20		VCC2	+1.8V power supply, not in use	3
21	LVTTL-I	P_Down/RST	Power down; when high, requires the module to limit power consumption to 1.5w or below ,2-wire serial interface must be functional in the low power mode	
			Reset; the falling edge initiates a complete reset of the module including the 2-wire Serial interface, equivalent to a power cycle	
22		VCC2	+1.8V power supply, not in use	3
23		GND	Ground	1
24	PECL-I	RefCLK+	Reference clock non-inverted input, ac coupled on the host board, not in use	3
25	PECL-I	RefCLK-	Reference clock inverted input, ac coupled on the host board, not in use	3
26		GND	Ground	1
27		GND	Ground	1
28	CML-I	TD-	Transmitter inverted data input	
29	CML-I	TD+	Transmitter non-inverted data input	
30		GND	Ground	1

Notes:

1. Module ground pins GND are isolated from the module case and chassis ground within the module.
2. Shall be pulled up with 4.7K-10Kohms to a voltage between 3.15V and 3.45V on the host board.
3. Not connected internally.

Absolute Maximum Ratings

It has to be noted that the operation in excess of any individual absolute maximum ratings might cause permanent damage to this module.

Parameters	Symbol	Min.	Max.	Unit
Bit Rate	Gbps	9.95	10.5	V
Power Dissipation			1.5	W
Storage Temperature	Tc	-40	85	°C
Operating Case Temperature	Tc	0	70	°C

Optical Characteristics

The following optical characteristics are defined over the Recommended Operating Environment unless otherwise specified.

Parameter	Symbol	Min.	Typ.	Max	Unit	Notes
Operating Reach, OM3 MMF				300	m	
Transmitter						
Center Wavelength	λ_t	840	850	860	nm	
Spectral Width			0.4	0.45	nm	
Average Optical Power	P_{avg}	-7.3		-1	dBm	
Transmitter and dispersion penalty (max)	TDP			3.2	dB	3
Average launch power of Off transmitter	P_{off}			-30	dBm	
Extinction Ratio	ER	3			dB	
Transmitter Mask (PRBS2 ³¹ -1@9.95G)		Compliant With ITU-T				
Receiver						
Center Wavelength	λ_r	840	850	860	nm	
Sensitivity (PRBS2 ³¹ -1@9.95G, BER<10 ⁻¹²)				-11.1	dBm	
Overload (PRBS2 ³¹ -1@9.95G, BER<10 ⁻¹²)		-1.0			dBm	
Los Assert	LosA	-30			dBm	
Los Dessert	LosD			-12	dBm	
Los Hysteresis	LosH	0.5			dB	

Note:

1. Average optical power shall be measured using the methods specified in TIA/EIA-455-95.
2. Receiver sensitivity is informative. Stressed receiver sensitivity shall be measured with conformance test signal for BER = 1x 10⁻¹².
3. Path penalty is intended as the power penalty of the interface between back-to-back and the maximum applied dispersion.

Electrical Characteristics

The following electrical characteristics are defined over the Recommended Operating Environment unless otherwise specified.

Parameter	Symbol	Min.	Typical	Max	Unit	Notes
Data Rate		9.953		10.5	Gbps	
Data Input Swing Differential/TX		180		1200	mV	
Data Output Swing Differential/RX		300		850	mV	
Date Differential Impedance		90	100	110	Ω	
Output High		2.4		V _{cc}	V	
Output Low		0		0.4	V	
Input High		2		V _{cc} +0.3	V	
Input Low		0		0.8	V	
LOS Assert Time	T _{LOSA}			100	us	
LOS De-assert Time	T _{LOSD}			100	us	

Typical Interface Circuit

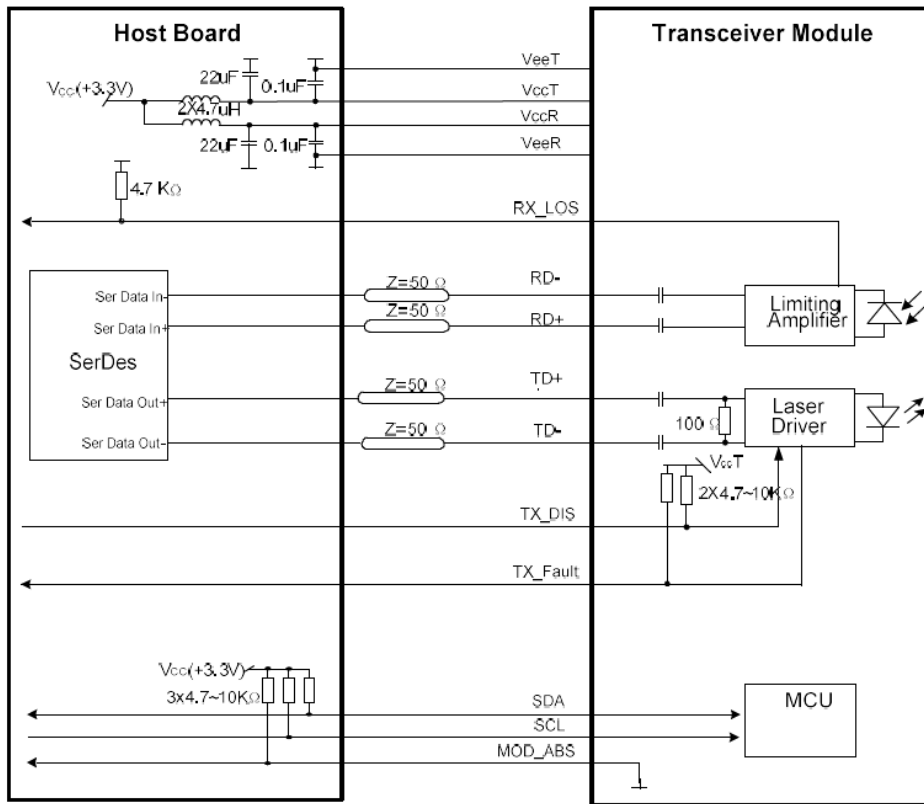

EEPROM Memory Map

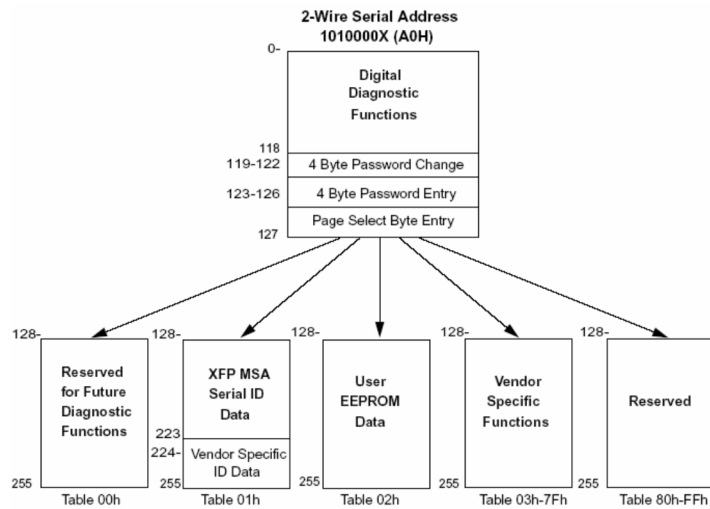

Mechanical Dimensions

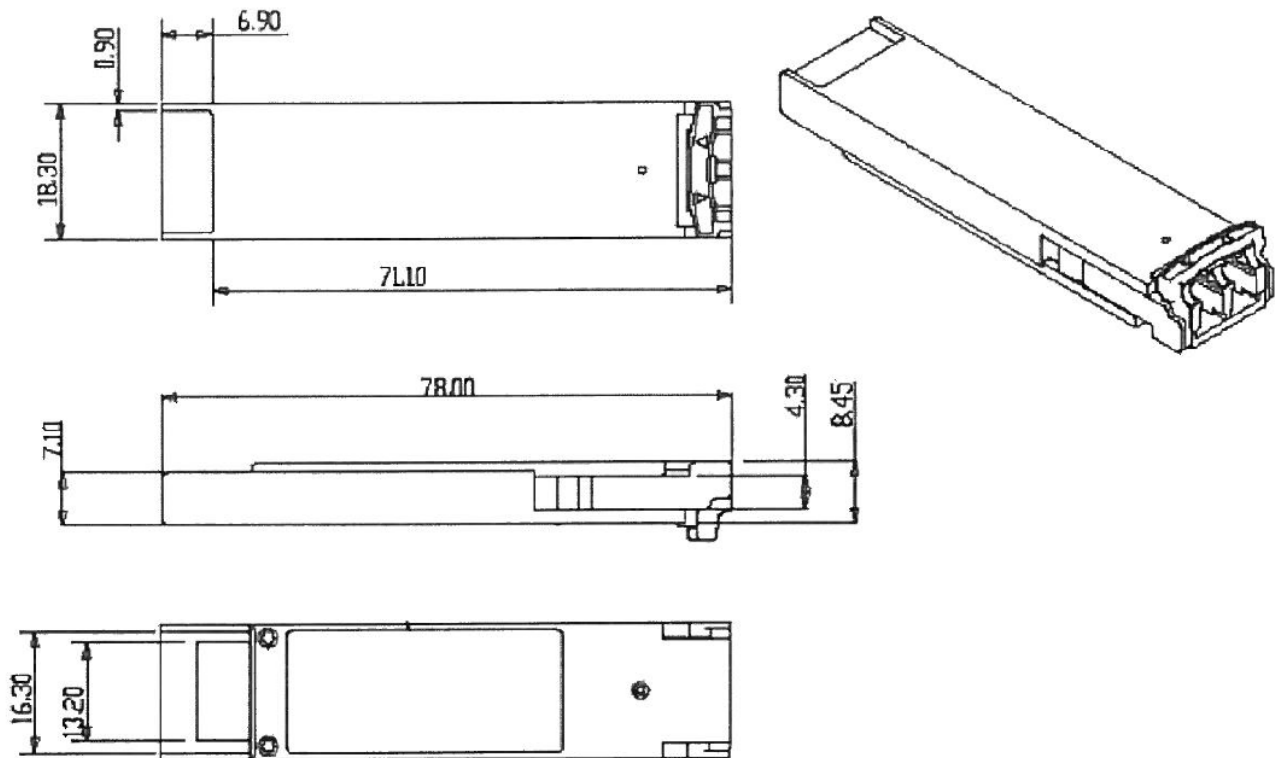

ESD

This transceiver is specified as ESD threshold 2kV for all electrical input pins, tested per MIL-STD-883, Method 3015.4 /JESD22-A114-A (HBM). However, normal ESD precautions are still required during the handling of this module. This transceiver is shipped in ESD protective packaging. It should be removed from the packaging and handled only in an ESD protected environment.

LASER Safety

This is a Class 1 Laser Product according to IEC/EN60825-1:2014 (Third Edition).. This product complies with 21 CFR 1040.10 and 1040.11 except for deviations pursuant to Laser Notice No. 50, dated (June 24, 2007)

Revision History

Date	Version	Description
03/12/2018	1.0	Initial release

Компания «Океан Электроники» предлагает заключение долгосрочных отношений при поставках импортных электронных компонентов на взаимовыгодных условиях!

Наши преимущества:

- Поставка оригинальных импортных электронных компонентов напрямую с производств Америки, Европы и Азии, а так же с крупнейших складов мира;
- Широкая линейка поставок активных и пассивных импортных электронных компонентов (более 30 млн. наименований);
- Поставка сложных, дефицитных, либо снятых с производства позиций;
- Оперативные сроки поставки под заказ (от 5 рабочих дней);
- Экспресс доставка в любую точку России;
- Помощь Конструкторского Отдела и консультации квалифицированных инженеров;
- Техническая поддержка проекта, помощь в подборе аналогов, поставка прототипов;
- Поставка электронных компонентов под контролем ВП;
- Система менеджмента качества сертифицирована по Международному стандарту ISO 9001;
- При необходимости вся продукция военного и аэрокосмического назначения проходит испытания и сертификацию в лаборатории (по согласованию с заказчиком);
- Поставка специализированных компонентов военного и аэрокосмического уровня качества (Xilinx, Altera, Analog Devices, Intersil, Interpoint, Microsemi, Actel, Aeroflex, Peregrine, VPT, Syfer, Eurofarad, Texas Instruments, MS Kennedy, Miteq, Cobham, E2V, MA-COM, Hittite, Mini-Circuits, General Dynamics и др.);

Компания «Океан Электроники» является официальным дистрибьютором и эксклюзивным представителем в России одного из крупнейших производителей разъемов военного и аэрокосмического назначения «JONHON», а так же официальным дистрибьютором и эксклюзивным представителем в России производителя высокотехнологичных и надежных решений для передачи СВЧ сигналов «FORSTAR».



JONHON

«JONHON» (основан в 1970 г.)

Разъемы специального, военного и аэрокосмического назначения:

(Применяются в военной, авиационной, аэрокосмической, морской, железнодорожной, горно- и нефтедобывающей отраслях промышленности)

«FORSTAR» (основан в 1998 г.)

ВЧ соединители, коаксиальные кабели, кабельные сборки и микроволновые компоненты:

(Применяются в телекоммуникациях гражданского и специального назначения, в средствах связи, РЛС, а так же военной, авиационной и аэрокосмической отраслях промышленности).



Телефон: 8 (812) 309-75-97 (многоканальный)

Факс: 8 (812) 320-03-32

Электронная почта: ocean@oceanchips.ru

Web: <http://oceanchips.ru/>

Адрес: 198099, г. Санкт-Петербург, ул. Калинина, д. 2, корп. 4, лит. А