

DESIGNED & DIMENSIONED
IN MILLIMETERS [INCHES]

MEC5-XXX-XX-X-RA-XX-TR

DO NOT
SCALE FROM
THIS PRINT

No OF POSITIONS (PER ROW)

-030, -040, -050,
-060, -070, -080

TAPE & REEL

OPTION
(REQUIRED)

-W1: WELD TAB THROUGH HOLE
(SEE FIG 2, SHT 3)
-W2: WELD TAB SURFACE MOUNT
(SEE FIG 1)

CARD THICKNESS

-01: FOR .062" THICK BOARD

PLATING SPECIFICATION

-L: 10µ" GOLD IN CONTACT AREA,
MATTE TIN TAIL
-S: 30µ" GOLD IN CONTACT AREA,
MATTE TIN TAIL

ROW SPECIFICATION

-RA: RIGHT ANGLE

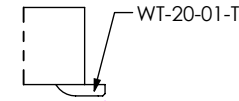
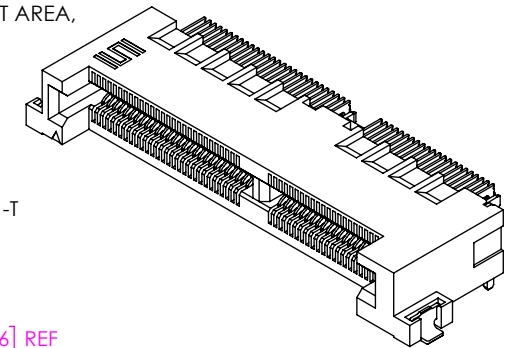
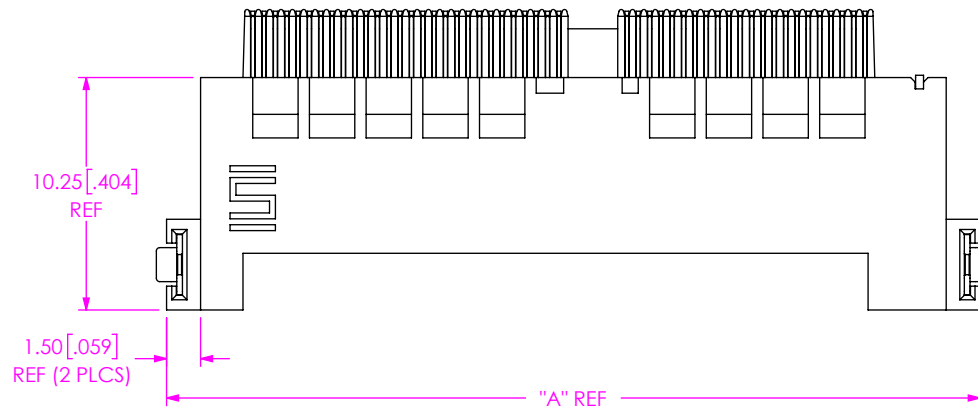

DETAIL 'A'
SCALE 6:1

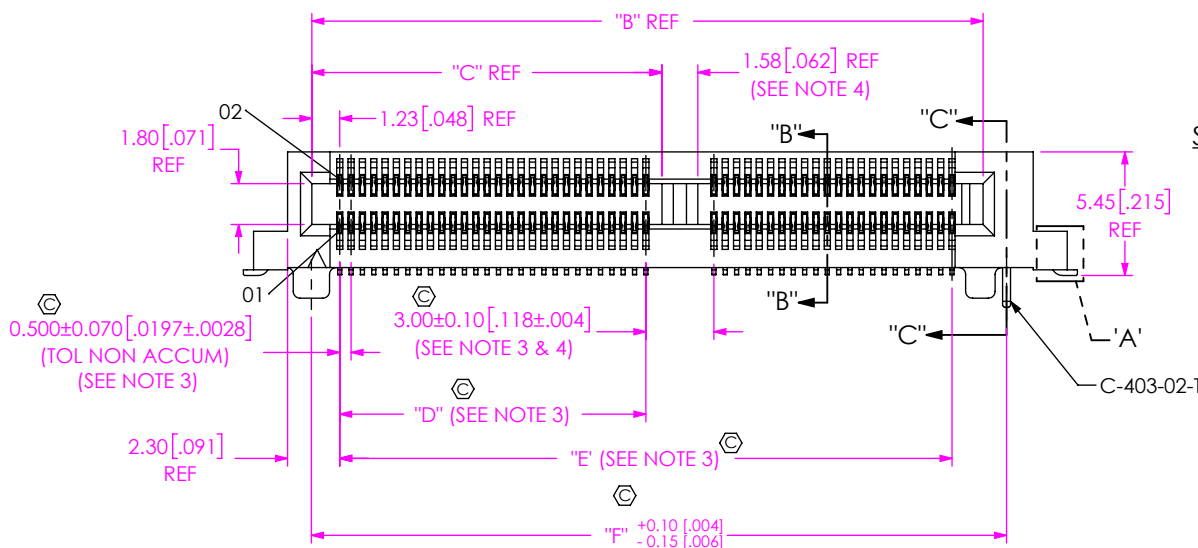

TABLE 1

| NO OF POS | "A" | "B" | "C" |
|-----------|---------------|---------------|---------------|
| -030 | 23.38 [0.920] | 17.10 [0.673] | N/A |
| -040 | 28.38 [1.117] | 22.10 [0.870] | N/A |
| -050 | 35.88 [1.413] | 29.60 [1.165] | 15.44 [0.608] |
| -060 | 40.88 [1.609] | 34.60 [1.362] | 17.94 [0.706] |
| -070 | 45.88 [1.806] | 39.60 [1.559] | 20.44 [0.805] |
| -080 | 50.88 [2.003] | 44.60 [1.756] | 22.94 [0.903] |

| NO OF POS | "D" | "E" | "F" |
|-----------|---------------|---------------|---------------|
| -030 | N/A | 14.50 [0.571] | 18.16 [0.715] |
| -040 | N/A | 19.50 [0.768] | 23.16 [0.912] |
| -050 | 13.50 [0.531] | 27.00 [1.063] | 30.66 [1.207] |
| -060 | 16.00 [0.630] | 32.00 [1.260] | 35.66 [1.404] |
| -070 | 18.50 [0.728] | 37.00 [1.457] | 40.66 [1.601] |
| -080 | 21.00 [0.827] | 42.00 [1.654] | 45.66 [1.798] |

FIG 1
MEC5-050-01-X-D-RA-W2-TR SHOWN

NOTES:

- ⊗ REPRESENTS A CRITICAL DIMENSION.
- MINIMUM PUSHOUT FORCE: 0.5 LBS FOR C-401, WT-20, WT-51; 1.0 LBS FOR C-403.
- MEASURE BOTH TOP AND BOTTOM ROWS.
- POLARIZATION RIB IS NOT PRESENT ON -030 & -040 POSITIONS.
- FOR QUANTITIES UP TO 49 PCS., NO LEADER, TRAILER OR REEL WILL BE SUPPLIED.
FOR QUANTITIES OF 50-124 PCS., NO LEADER OR TRAILER WILL BE SUPPLIED,
SPICES MAY BE PRESENT.

UNLESS OTHERWISE SPECIFIED,
DIMENSIONS ARE IN MILLIMETERS.
TOLERANCES ARE:
DECIMALS ANGLES
X.X: ±0.3 [.01] 2°
X.XX: ±0.10 [.004]
X.XXX: ±0.051 [.0020]

PROPRIETARY NOTE
THIS DOCUMENT CONTAINS CONFIDENTIAL AND PROPRIETARY INFORMATION AND ALL DESIGN, MANUFACTURING, REPRODUCTION, USE, PATENT RIGHTS AND SALES RIGHTS ARE EXPRESSLY RESERVED BY SAMTEC, INC. THIS DOCUMENT SHALL NOT BE DISCLOSED, IN WHOLE OR PART, TO ANY UNAUTHORIZED PERSON OR ENTITY NOR REPRODUCED, TRANSFERRED OR INCORPORATED IN ANY OTHER PROJECT IN ANY MANNER WITHOUT THE EXPRESS WRITTEN CONSENT OF SAMTEC, INC.

MATERIAL: DO NOT SCALE DRAWING SHEET SCALE: 3:1
INSULATOR: LCP, UL 94 V0, COLOR: BLACK
CONTACT: Cu ALLOY
WELD TAB: BRASS ALLOY



520 PARK EAST BLVD, NEW ALBANY, IN 47150
PHONE: 812-944-6733 FAX: 812-948-5047
e-Mail: info@SAMTEC.com code 53322

DESCRIPTION:
0.5mm HIGH SPEED EDGE CARD ASSEMBLY
DWG. NO.
MEC5-XXX-XX-X-RA-XX-TR
BY: JESSIE W 6/3/2015 SHEET 1 OF 4

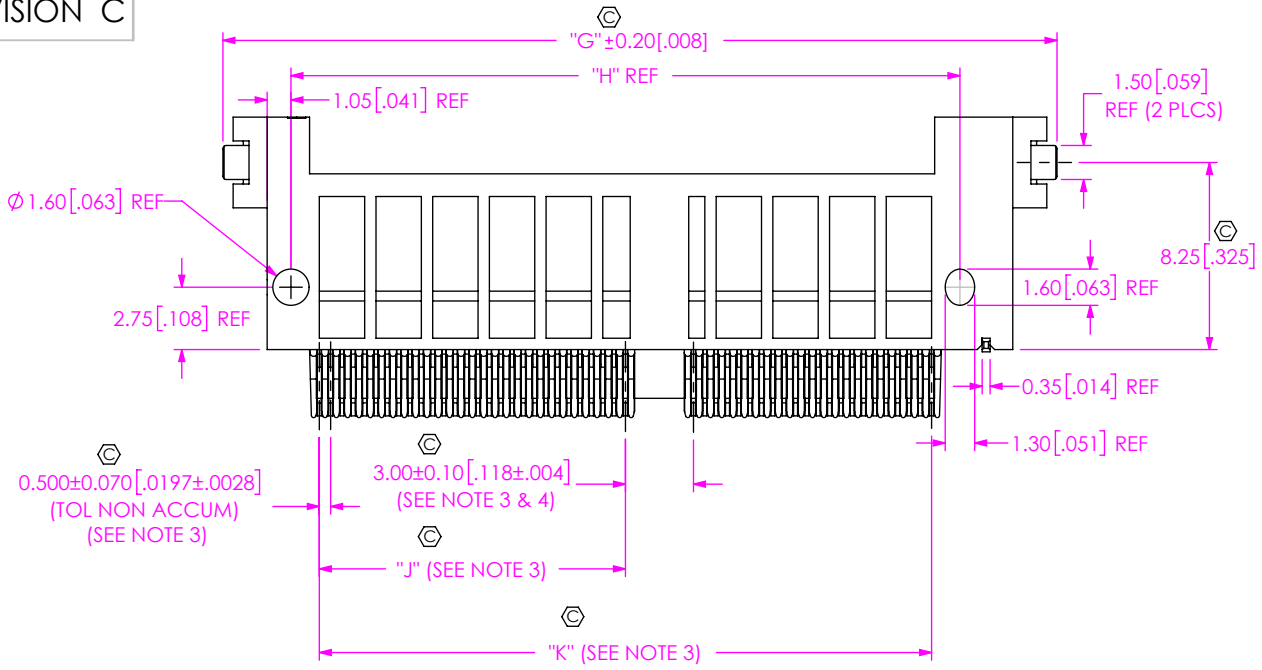

BOTTOM VIEW

| TABLE 2 | | |
|-----------|---------------|---------------|
| NO OF POS | "G" | "H" |
| -030 | 24.28 [0.956] | 17.00 [0.669] |
| -040 | 29.28 [1.153] | 22.00 [0.866] |
| -050 | 36.78 [1.448] | 29.50 [1.161] |
| -060 | 41.78 [1.645] | 34.50 [1.358] |
| -070 | 46.78 [1.842] | 39.50 [1.555] |
| -080 | 51.78 [2.039] | 44.50 [1.752] |

| NO OF POS | "J" | "K" |
|-----------|---------------|---------------|
| -030 | N/A | 14.50 [0.571] |
| -040 | N/A | 19.50 [0.768] |
| -050 | 13.50 [0.531] | 27.00 [1.063] |
| -060 | 16.00 [0.630] | 32.00 [1.260] |
| -070 | 18.50 [0.728] | 37.00 [1.457] |
| -080 | 21.00 [0.827] | 42.00 [1.654] |

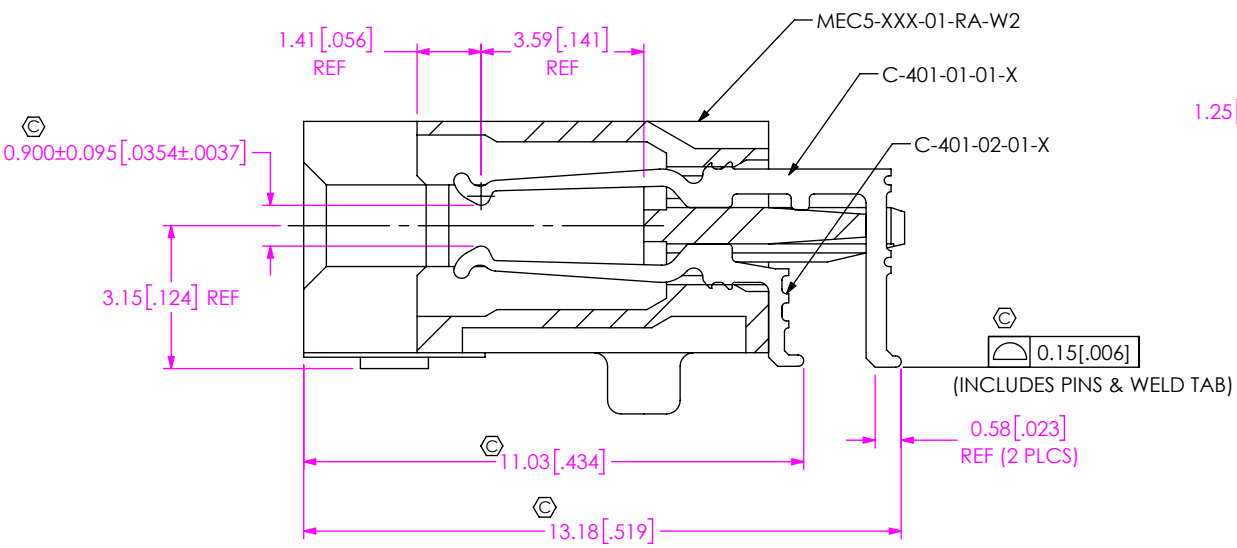

SECTION "B"- "B"
SCALE 6 : 1

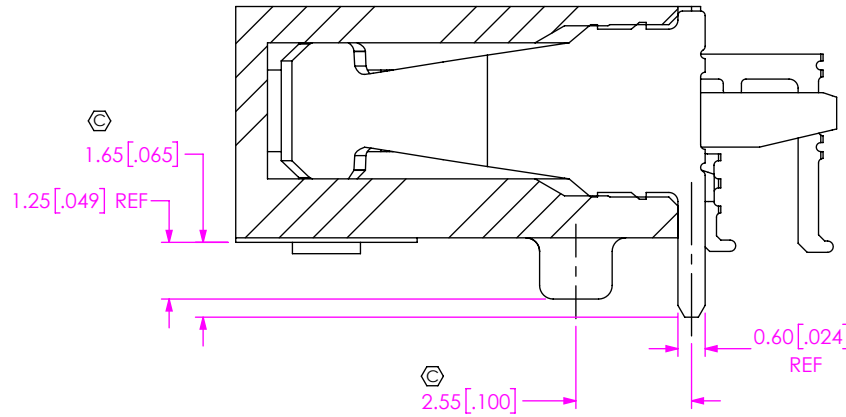

SECTION "C"- "C"
SCALE 6 : 1

PROPRIETARY NOTE
THIS DOCUMENT CONTAINS CONFIDENTIAL AND PROPRIETARY INFORMATION AND ALL DESIGN, MANUFACTURING, REPRODUCTION, USE, PATENT RIGHTS AND SALES RIGHTS ARE EXPRESSLY RESERVED BY SAMTEC, INC. THIS DOCUMENT SHALL NOT BE DISCLOSED, IN WHOLE OR PART, TO ANY UNAUTHORIZED PERSON OR ENTITY NOR REPRODUCED, TRANSFERRED OR INCORPORATED IN ANY OTHER PROJECT IN ANY MANNER WITHOUT THE EXPRESS WRITTEN CONSENT OF SAMTEC, INC.

DO NOT SCALE DRAWING

SHEET SCALE: 3:1



520 PARK EAST BLVD, NEW ALBANY, IN 47150
PHONE: 812-944-6733 FAX: 812-948-5047
e-Mail info@SAMTEC.com code 55322

DESCRIPTION:
0.5mm HIGH SPEED EDGE CARD ASSEMBLY

DWG. NO.
MEC5-XXX-XX-X-RA-XX-TR

BY: JESSIE W 6/3/2015 SHEET 2 OF 4

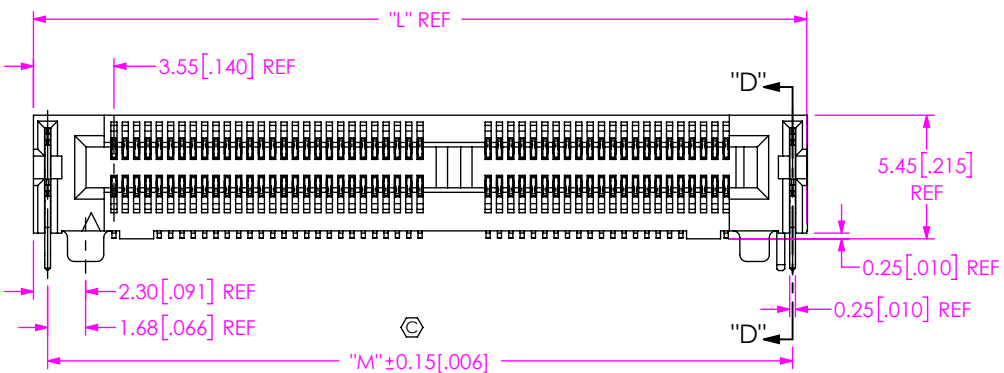
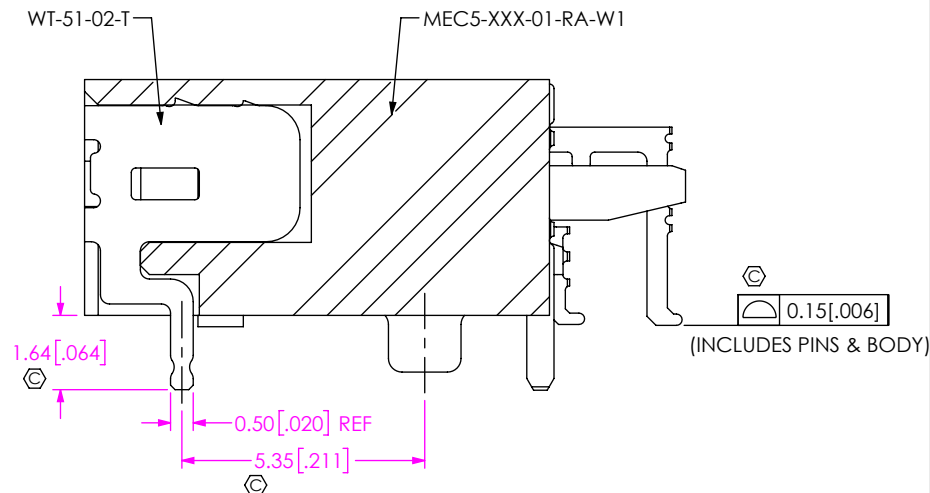
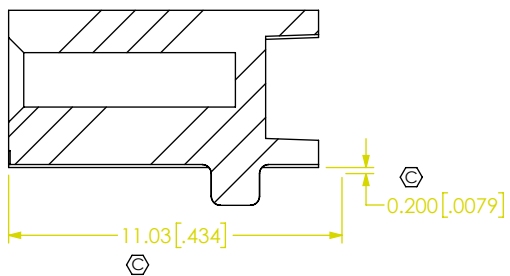

FIG 2
MEC5-050-01-X-D-RA-W1-TR SHOWN
(DIFFERENT AS SHOWN, OTHERWISE SAME AS FIG 1)



SECTION "D"-"D"
SCALE 6:1



IN-PROCESS 1 FOR W1
FILL C-401-02-01-X

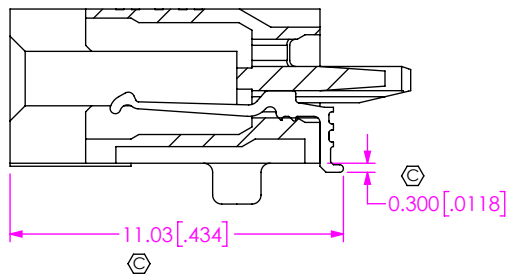

IN-PROCESS 1 FOR W2
FILL C-401-02-01-X

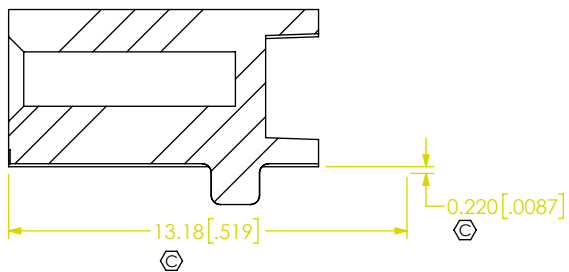

IN-PROCESS 2 FOR W1
FILL C-401-01-01-X

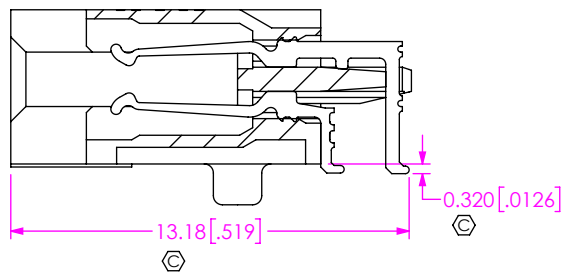

IN-PROCESS 2 FOR W2
FILL C-401-01-01-X

TABLE 3

| NO OF POS | "L" | "M" |
|-----------|---------------|---------------|
| -030 | 22.88 [0.901] | 21.63 [0.852] |
| -040 | 27.88 [1.098] | 26.63 [1.048] |
| -050 | 35.38 [1.393] | 34.13 [1.344] |
| -060 | 40.38 [1.590] | 39.13 [1.541] |
| -070 | 45.38 [1.787] | 44.13 [1.737] |
| -080 | 50.38 [1.983] | 49.13 [1.934] |

PROPRIETARY NOTE
THIS DOCUMENT CONTAINS CONFIDENTIAL AND PROPRIETARY INFORMATION AND ALL DESIGN, MANUFACTURING, REPRODUCTION, USE, PATENT RIGHTS AND SALES RIGHTS ARE EXPRESSLY RESERVED BY SAMTEC, INC. THIS DOCUMENT SHALL NOT BE DISCLOSED, IN WHOLE OR PART, TO ANY UNAUTHORIZED PERSON OR ENTITY NOR REPRODUCED, TRANSFERRED OR INCORPORATED IN ANY OTHER PROJECT IN ANY MANNER WITHOUT THE EXPRESS WRITTEN CONSENT OF SAMTEC, INC.

DO NOT SCALE DRAWING

SHEET SCALE: 3:1



520 PARK EAST BLVD, NEW ALBANY, IN 47150
PHONE: 812-944-6733 FAX: 812-948-5047
e-Mail info@SAMTEC.com code 55322

DESCRIPTION:
0.5mm HIGH SPEED EDGE CARD ASSEMBLY

DWG. NO.
MEC5-XXX-XX-X-RA-XX-TR

BY: JESSIE W 6/3/2015 SHEET 3 OF 4

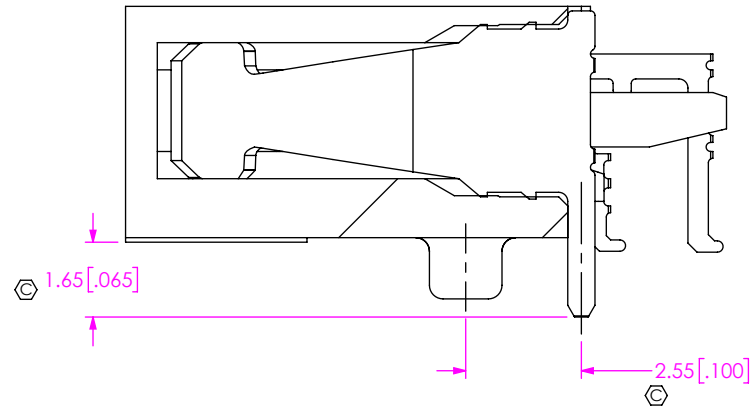

IN-PROCESS 3
FILL C-403-02-T

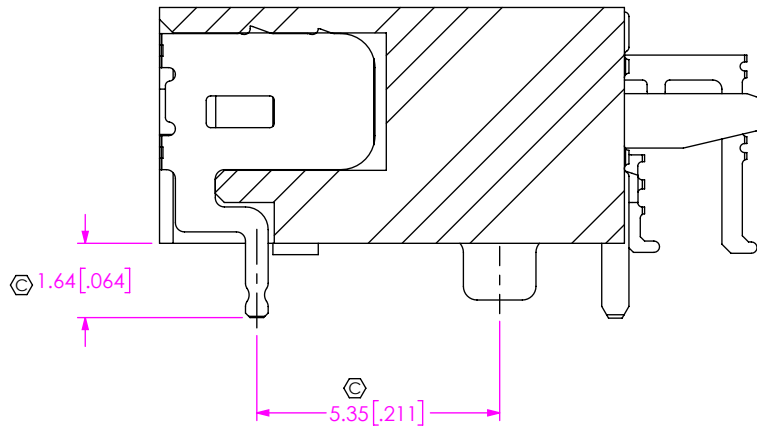

IN-PROCESS 4 FOR W1
FILL WT-51-02-T

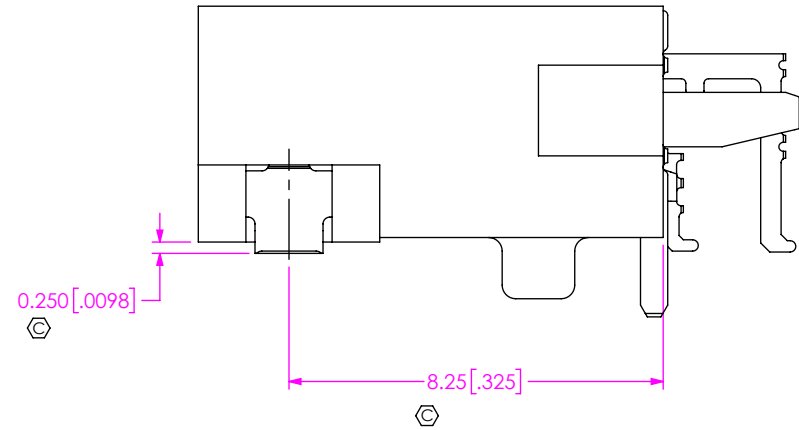

IN-PROCESS 4 FOR W2
FILL WT-20-01-T

| | |
|---|--|
| <p>PROPRIETARY NOTE</p> <p>THIS DOCUMENT CONTAINS CONFIDENTIAL AND PROPRIETARY INFORMATION AND ALL DESIGN, MANUFACTURING, REPRODUCTION, USE, PATENT RIGHTS AND SALES RIGHTS ARE EXPRESSLY RESERVED BY SAMTEC, INC. THIS DOCUMENT SHALL NOT BE DISCLOSED, IN WHOLE OR PART, TO ANY UNAUTHORIZED PERSON OR ENTITY NOR REPRODUCED, TRANSFERRED OR INCORPORATED IN ANY OTHER PROJECT IN ANY MANNER WITHOUT THE EXPRESS WRITTEN CONSENT OF SAMTEC, INC.</p> | <p>samtec</p> <p>520 PARK EAST BLVD, NEW ALBANY, IN 47150 PHONE: 812-944-6733 FAX: 812-948-5047 e-Mail info@SAMTEC.com code 55322</p> |
| <p>SHEET SCALE: 3:1</p> | <p>DESCRIPTION: 0.5mm HIGH SPEED EDGE CARD ASSEMBLY</p> |
| | <p>DWG. NO. MEC5-XXX-XX-X-RA-XX-TR</p> <p>BY: JESSIE W 6/3/2015 SHEET 4 OF 4</p> |

Компания «Океан Электроники» предлагает заключение долгосрочных отношений при поставках импортных электронных компонентов на взаимовыгодных условиях!

Наши преимущества:

- Поставка оригинальных импортных электронных компонентов напрямую с производств Америки, Европы и Азии, а так же с крупнейших складов мира;
- Широкая линейка поставок активных и пассивных импортных электронных компонентов (более 30 млн. наименований);
- Поставка сложных, дефицитных, либо снятых с производства позиций;
- Оперативные сроки поставки под заказ (от 5 рабочих дней);
- Экспресс доставка в любую точку России;
- Помощь Конструкторского Отдела и консультации квалифицированных инженеров;
- Техническая поддержка проекта, помощь в подборе аналогов, поставка прототипов;
- Поставка электронных компонентов под контролем ВП;
- Система менеджмента качества сертифицирована по Международному стандарту ISO 9001;
- При необходимости вся продукция военного и аэрокосмического назначения проходит испытания и сертификацию в лаборатории (по согласованию с заказчиком);
- Поставка специализированных компонентов военного и аэрокосмического уровня качества (Xilinx, Altera, Analog Devices, Intersil, Interpoint, Microsemi, Actel, Aeroflex, Peregrine, VPT, Syfer, Eurofarad, Texas Instruments, MS Kennedy, Miteq, Cobham, E2V, MA-COM, Hittite, Mini-Circuits, General Dynamics и др.);

Компания «Океан Электроники» является официальным дистрибьютором и эксклюзивным представителем в России одного из крупнейших производителей разъемов военного и аэрокосмического назначения «JONHON», а так же официальным дистрибьютором и эксклюзивным представителем в России производителя высокотехнологичных и надежных решений для передачи СВЧ сигналов «FORSTAR».



JONHON

«JONHON» (основан в 1970 г.)

Разъемы специального, военного и аэрокосмического назначения:

(Применяются в военной, авиационной, аэрокосмической, морской, железнодорожной, горно- и нефтедобывающей отраслях промышленности)

«FORSTAR» (основан в 1998 г.)

ВЧ соединители, коаксиальные кабели, кабельные сборки и микроволновые компоненты:

(Применяются в телекоммуникациях гражданского и специального назначения, в средствах связи, РЛС, а так же военной, авиационной и аэрокосмической отраслях промышленности).



Телефон: 8 (812) 309-75-97 (многоканальный)

Факс: 8 (812) 320-03-32

Электронная почта: ocean@oceanchips.ru

Web: <http://oceanchips.ru/>

Адрес: 198099, г. Санкт-Петербург, ул. Калинина, д. 2, корп. 4, лит. А