

**Applications**

- Automotive
- Instrumentation
- White goods
- Telecommunications

**Benefits**

- RoHS Compliant
- Halogen and Lead Free
- Sharp detection feeling
- Compact Size

**JJ Series – Detector Switches**

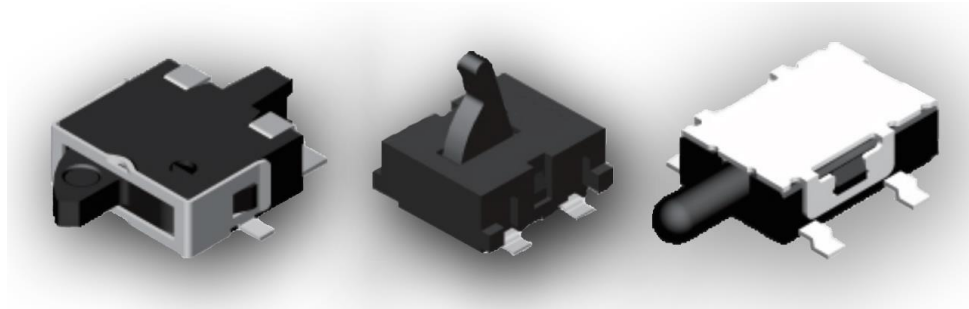

TE Connectivity is pleased to introduce its JJ Series of Detector Switches, suitable for a wide variety of applications given their several presentations ranging from horizontal or vertical actuated options as well as Gull-winged, J-leaded and Through-Hole mounting possibilities.

The Detector Switches will be offered in a wide range of sizes giving the possibility for countless applications going from automotive to telecommunications.

**JJ Series – Family Classification**

Series	Body Size
JJA	3.5x2.8 mm
JJB	3.5x2.98 mm
JJC	3.5x3.3 mm
JJD	4.2x3.6 mm
JJE	4.7x3.5 mm
JJF	4.7x3.8 mm
JJG	5.7x4.0 mm (High-Rating)
JJH	5.7x4.0 mm (Standard-Rating)
JJI	5.0x4.4 mm
JJJ	6.0x4.85 mm / 5.5x4.7 mm
JJK	6.3x3.0 mm
JJL	6.5x3.9 mm
JJM	5.7x4.0 mm
JJN	5.7x4.0 mm (Wedge)
JJO	10.0x3.8 mm
JJP	10.6x10.0 mm

**JJF Family – 4.7x3.8 mm**

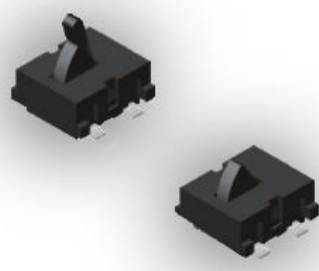
	Contact Rating	1mA, 5VDC Max.
	Contact Resistance	1Ω Max.
	Insulation Resistance	100MΩ Min. 100VDC
	Dielectric Strength	100VAC/1 minute
	Operating Force	40gF Max.
	Travel	5.30mm Stem--3.9mm 3.80mm Stem--2.6mm
	Operating Life	100,000 cycles
	Operating Temperature	-10°C to 60°C
	Storage Temperature	-20°C to 70°C

Features	Applications
<ul style="list-style-type: none"> <li>Guiding post for easy orientation</li> <li>3.80 &amp; 5.30mm stem height</li> </ul>	<ul style="list-style-type: none"> <li>DSC</li> <li>Detection of disc loading</li> </ul>

**Circuit**

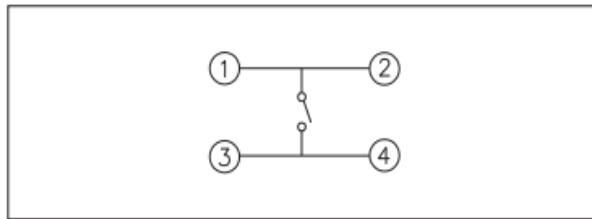

**How To Order**

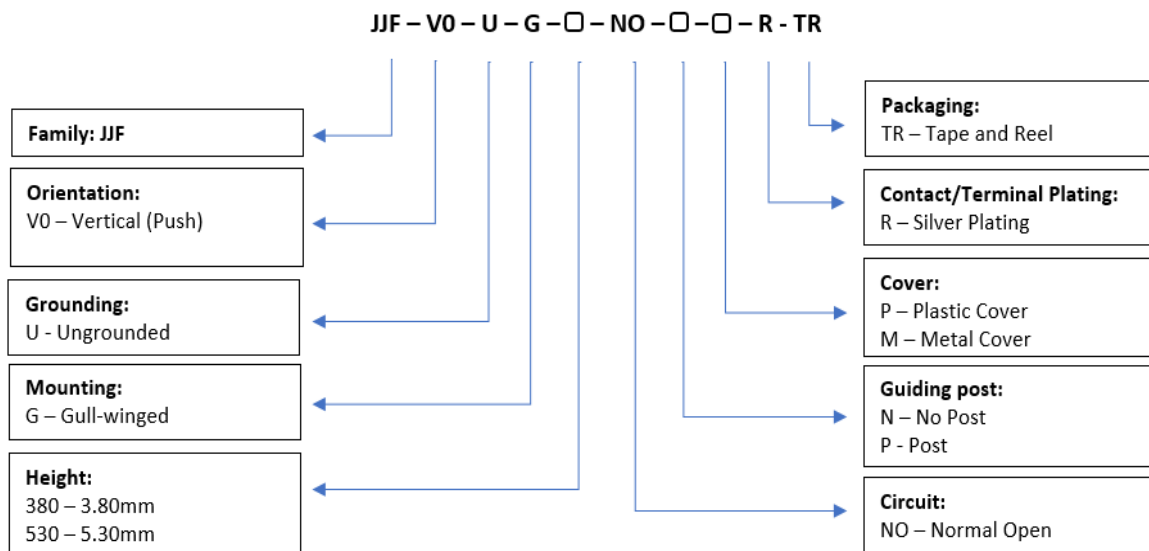

## Diagrams

### -5.30mm

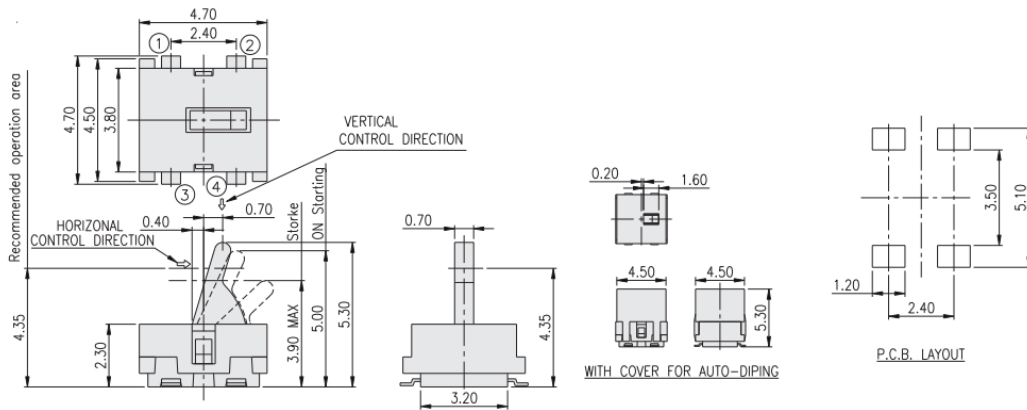

### -3.80mm

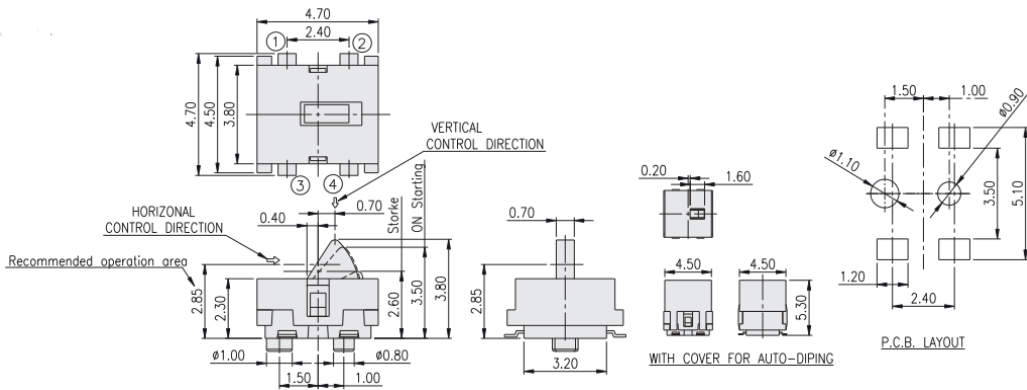

## PN List

Smart PN	Orientation	Grounding	Mounting	Height	Circuit	Guide Post	Cover	Plating	Packaging	MOQ	TE PN
JJFV0UG530NOPMRTR	Vertical Push	Ungrounded	Gull-winged	5.30 mm	NO	Post	Metal	Silver	Tape and Reel	900	2331364-1
JJFV0UG530NOPRTR	Vertical Push	Ungrounded	Gull-winged	5.30 mm	NO	Post	Plastic	Silver	Tape and Reel	900	2331365-1
JJFV0UG530NONMRTR	Vertical Push	Ungrounded	Gull-winged	5.30 mm	NO	No Post	Metal	Silver	Tape and Reel	900	2331366-1
JJFV0UG530NONPRTR	Vertical Push	Ungrounded	Gull-winged	5.30 mm	NO	No Post	Plastic	Silver	Tape and Reel	900	2331367-1
JJFV0UG380NOPMRTR	Vertical Push	Ungrounded	Gull-winged	3.80 mm	NO	Post	Metal	Silver	Tape and Reel	900	2331368-1
JJFV0UG380NOPRTR	Vertical Push	Ungrounded	Gull-winged	3.80 mm	NO	Post	Plastic	Silver	Tape and Reel	1,000	2331369-1
JJFV0UG380NONMRTR	Vertical Push	Ungrounded	Gull-winged	3.80 mm	NO	No Post	Metal	Silver	Tape and Reel	900	2331370-1
JJFV0UG380NONPRTR	Vertical Push	Ungrounded	Gull-winged	3.80 mm	NO	No Post	Plastic	Silver	Tape and Reel	1,000	2331372-1

## 1. Style

“Detector Switches” are mainly used as signal switches of electric devices, with the general requirements of mechanical and electrical characteristic.

1.1 Operating Temperature Range: -10°C to 60°C

1.2 Storage Temperature Range: -20°C to 70°C

1.3 The shelf life of product is within 6 months.

**2. Current Range:** 1mA, 5 VDC

**3. Type of Actuation:** Tactile feedback

## 4. Test Sequence:

	Item	Description	Test Conditions	Requirements
Appearance	1	Visual Examination	Physical inspection without applying any external forces.	There shall be no defects that affect the serviceability of the product.
Electric Performance	2	Contact Resistance	Actuate the switch 4.35mm (5.30mm Stem); 2.85mm (3.80mm Stem) and measure contact resistance using a micro-Ohmmeter.	1Ω Max.
	3	Insulation Resistance	Measurements shall be made at 100 VDC potential between terminals and cover.	100MΩ Min.
	4	Dielectric Withstanding Voltage	100 VAC (50Hz or 60Hz) shall be applied across terminals and cover for 1 minute	There shall be no breakdown or flashover
	5	Capacitance	Capacitance shall be measured at 1 MHz between terminals.	5 pF Max.
	6	Operating Force	As the specification shows operating force is measured	40gF Max (.4N Max)



Mechanical Performance	7	Contact (On) point	-----	As the specification shows ON start position												
	8	Stop Strength	Apply vertical static load of 1KgF(9.8N) shall be applied in the direction of stem operation for a period of 60 seconds	As shown in items 2 through 7.												
	9	Solder Heat Resistance	<p>(See chart below)</p> <p>ON starting before reflow:</p> <table border="1"> <tr> <td colspan="2">5.30mm Stem</td> <td colspan="2">3.80mm Stem</td> </tr> <tr> <td>5.00</td> <td>+0.2</td> <td>3.50</td> <td>+0.2</td> </tr> <tr> <td></td> <td>-0.3</td> <td></td> <td>-0.3</td> </tr> </table>	5.30mm Stem		3.80mm Stem		5.00	+0.2	3.50	+0.2		-0.3		-0.3	1) Shall be free from pronounced backlash and falling-off or breakage terminals 2) As shown in items 2 through 8.
	5.30mm Stem		3.80mm Stem													
	5.00	+0.2	3.50	+0.2												
		-0.3		-0.3												
10	Vibration	Test per Method 201A of MIL-STD-202F 1) Swing distance=1.5mm 2) Frequency: 10-55-10Hz in 1-min/cycle. 3) Direction: 3 vertical directions including the directions of operation 4) Test time: 2 hours each direction	As shown in items 2 through 8.													
11	Shock	Test per Method 213B condition A of MIL-STD-202F 1) Acceleration; 50G 2) Action time: 11±1m seconds 3) Testing Direction: 6 sides 4) Test Cycle: 3 times in each direction	As shown in items 2 through 8.													
12	Solderability	1) Temperature: 245±3°C Lead-Free solder: M705E JIS Z 3282 A (Tin 96.5%, Silver 3%, Copper 0.5%) 2) Flux: 5-10 sec. 3) Duration of solder Immersion: 3±0.5sec.	No anti-soldering and the coverage of dipping into solder must more than 75% was requested.													
Durability	13	Operating Life	Measurements shall be made following the test forth below: 1) 1mA,5 VDC resistive load 2) Apply a static load in the direction of operation equal to the operating force to the center of the stem. 3) Rate of Operation: 20 to 25 operations per minute. 4) Cycle of Operation: 100,000 cycles Min.	1) As shown in items 4 to 5 2) Insulation Resistance: 10MΩ Min. 3) Contact Resistance: 2Ω Max.												

Weather-proof	14	Resistance Low Temperature	Following the test set forth below the sample shall be left in normal temperature and humidity conditions for 1 hour before the measurements are made: 1) Temperature: $-40\pm 2^{\circ}\text{C}$ 2) Time: 96 hours	As shown in items 2 to 8.
	15	Heat Resistance	Following the test set forth below the sample shall be left in normal temperature and humidity conditions for 1 hour before the measurements are made: 1) Temperature: $85\pm 2^{\circ}\text{C}$ 2) Time: 96 hours	
	16	Humidity Resistance	Following the test set forth below the sample shall be left in normal temperature and humidity conditions for 1 hour before the measurements are made: 1) Temperature: $40\pm 2^{\circ}\text{C}$ 2) Relative Humidity: 90 to 95% 3) Time: 96 hours	1) As shown in items 4 to 8. 2) Insulation Resistance: $10\text{M}\Omega$ Min.

**5. Soldering Conditions:**

■ Recommended Soldering Profile for the JJF Series



■ The temperatures defined above are the temperatures measured on the surface of the Printed Circuit Board. There are cases where the printed circuit board's temperature differs greatly from the temperature of the switch. Critical note: the switch's surface temperature must not exceed  $260^{\circ}\text{C}$ .

■ Manual Soldering

Soldering Temperature:  $350^{\circ}\text{C}$  Max.  
Continuous Soldering Time: 5 second Max.

■ Precautions in Handling

- Care must be taken to ensure excess flux on the top surface of the printed circuit board does not adhere to the switch.
- Do not wash the switch.

---

■ Recommended storage conditions:

Store the products in the original packaging material. After opening the package, the remaining products must be stored in the appropriate moisture-proof & airtight environment.

Do not store the switch in the following environment or it may affect performance and solderability:

1. temperatures below -10° C to 40°C & humidity at 85% (min)
2. environment with corrosive gas
3. storage over 6 months
4. place in direct sunlight

Компания «Океан Электроники» предлагает заключение долгосрочных отношений при поставках импортных электронных компонентов на взаимовыгодных условиях!

Наши преимущества:

- Поставка оригинальных импортных электронных компонентов напрямую с производств Америки, Европы и Азии, а так же с крупнейших складов мира;
- Широкая линейка поставок активных и пассивных импортных электронных компонентов (более 30 млн. наименований);
- Поставка сложных, дефицитных, либо снятых с производства позиций;
- Оперативные сроки поставки под заказ (от 5 рабочих дней);
- Экспресс доставка в любую точку России;
- Помощь Конструкторского Отдела и консультации квалифицированных инженеров;
- Техническая поддержка проекта, помощь в подборе аналогов, поставка прототипов;
- Поставка электронных компонентов под контролем ВП;
- Система менеджмента качества сертифицирована по Международному стандарту ISO 9001;
- При необходимости вся продукция военного и аэрокосмического назначения проходит испытания и сертификацию в лаборатории (по согласованию с заказчиком);
- Поставка специализированных компонентов военного и аэрокосмического уровня качества (Xilinx, Altera, Analog Devices, Intersil, Interpoint, Microsemi, Actel, Aeroflex, Peregrine, VPT, Syfer, Eurofarad, Texas Instruments, MS Kennedy, Miteq, Cobham, E2V, MA-COM, Hittite, Mini-Circuits, General Dynamics и др.);

Компания «Океан Электроники» является официальным дистрибьютором и эксклюзивным представителем в России одного из крупнейших производителей разъемов военного и аэрокосмического назначения «JONHON», а так же официальным дистрибьютором и эксклюзивным представителем в России производителя высокотехнологичных и надежных решений для передачи СВЧ сигналов «FORSTAR».



## JONHON

«JONHON» (основан в 1970 г.)

Разъемы специального, военного и аэрокосмического назначения:

(Применяются в военной, авиационной, аэрокосмической, морской, железнодорожной, горно- и нефтедобывающей отраслях промышленности)

«FORSTAR» (основан в 1998 г.)

ВЧ соединители, коаксиальные кабели, кабельные сборки и микроволновые компоненты:

(Применяются в телекоммуникациях гражданского и специального назначения, в средствах связи, РЛС, а так же военной, авиационной и аэрокосмической отраслях промышленности).



Телефон: 8 (812) 309-75-97 (многоканальный)

Факс: 8 (812) 320-03-32

Электронная почта: [ocean@oceanchips.ru](mailto:ocean@oceanchips.ru)

Web: <http://oceanchips.ru/>

Адрес: 198099, г. Санкт-Петербург, ул. Калинина, д. 2, корп. 4, лит. А