

- High power density power supply (open frame)
- Certification according to IEC/EN/ES 60601-1 3rd edition for 2 x MOPP
- Low leakage current <75 µA rated for BF applications
- EMC compliance to IEC 60601-1-2 4th edition
- Risk management process according to ISO 14971 incl. risk management file
- Acceptance criteria for electronic assemblies acc. to IPC-A-610 Level 3
- Protection class II
- Operating up to 5000 m altitude
- Ready to meet ErP directive, no load power consumption <75 mW
- 5-year product warranty

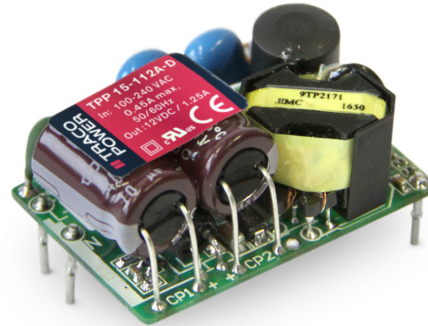

The TPP 15A-D AC/DC power supplies feature a reinforced double I/O isolation system according to medical safety standards IEC/EN/ES 60601-1 3rd edition for 2 x MOPP approved for an operating altitude of 5000 m. The earth leakage current is below 75 µA what makes the units suitable for BF (body floating) applications. The excellent efficiency of up to 88.5% offers a high power density in the packaging format 1.0" x 1.5". The full load operating temperature range covers -40°C to +60°C while it goes up to 85°C with 50% load derating. The units operate in compliance to the medical EMC emission and immunity levels according to latest standard IEC 60601-1-2 4th edition.

Models

Order Code	Output Power max.	Output Voltage nom. (adjustable)	Output Current max.	Efficiency typ.
TPP 15-103A-D	15 W	3.3 VDC (2.97 - 3.63 VDC)	4'000 mA	84 %
TPP 15-105A-D		5 VDC (4.5 - 5.5 VDC)	3'000 mA	86 %
TPP 15-109A-D		9 VDC (8.1 - 9.9 VDC)	1'670 mA	86 %
TPP 15-112A-D		12 VDC (10.8 - 13.2 VDC)	1'250 mA	87 %
TPP 15-115A-D		15 VDC (13.5 - 16.5 VDC)	1'000 mA	87 %
TPP 15-124A-D		24 VDC (21.6 - 26.4 VDC)	625 mA	88 %
TPP 15-136A-D		36 VDC (32.4 - 39.6 VDC)	417 mA	88 %
TPP 15-148A-D		48 VDC (43.2 - 52.8 VDC)	313 mA	89 %

Note - Other output models are available on request.

Input Specifications

Input Voltage	- AC Range	85 - 264 VAC (Full Range)
	- DC Range	120 - 370 VDC (Designed for, no certification)
Input Frequency		47 - 63 Hz
Input Current	- Full Load & Vin = 230 VAC	300 mA max.
	- Full Load & Vin = 115 VAC	450 mA max.
Power Consumption	- at no Load	75 mW max. (Ready to meet ErP directive)
Input Inrush Current	- at 230 VAC	40 A max.
Input Protection		T 1.6 A / 250 VAC (Internal Fuse in L & N)

Output Specifications

Output Voltage Adjustment		±10% (By external trim resistor)
	Refer to Application Note:	www.tracopower.com/overview/tpp15a-d Output power must not exceed rated power!
Voltage Set Accuracy		±1% max.
Regulation	- Input Variation (Vmin - Vmax)	0.2% max.
	- Load Variation (0 - 100%)	0.7% max. (3.3 and 5 VDC model) 0.5% max. (other output models)
Ripple and Noise (20 MHz Bandwidth)	3.3 VDC model:	40 mVp-p typ. (with 10 µF X5R)
	5 VDC model:	40 mVp-p typ. (with 10 µF X5R)
	9 VDC model:	70 mVp-p typ. (with 10 µF X5R)
	12 VDC model:	70 mVp-p typ. (with 10 µF X5R)
	15 VDC model:	70 mVp-p typ. (with 10 µF X5R)
	24 VDC model:	100 mVp-p typ. (with 10 µF X5R)
	36 VDC model:	100 mVp-p typ. (with 10 µF X5R)
	48 VDC model:	140 mVp-p typ. (with 1 µF X7R)
Capacitive Load	3.3 VDC model:	6'000 µF max.
	5 VDC model:	4'000 µF max.
	9 VDC model:	1'860 µF max.
	12 VDC model:	1'200 µF max.
	15 VDC model:	820 µF max.
	24 VDC model:	470 µF max.
	36 VDC model:	220 µF max.
48 VDC model:	150 µF max.	
Minimum Load		Not required
Temperature Coefficient		±0.02 %/K max.
Hold-up Time	- at 115 VAC	8 ms min.
Start-up Time	- at 230 VAC	500 ms max.
Short Circuit Protection		Continuous, Automatic recovery
Output Current Limitation		120 - 200% of Iout max.
		145% typ. of Iout max.
Overvoltage Protection		125 - 140% of Vout nom.
Transient Response	- Response Deviation	8% max. (75% to 100% Load Step)
	- Response Time	500 µs typ. (75% to 100% Load Step)

All specifications valid at nominal input voltage, full load and +25°C after warm-up time unless otherwise stated.

Safety Specifications

Safety Standards	- IT / Multimedia Equipment	EN 62368-1 IEC 62368-1 UL 62368-1
	- Household	IEC 60335-1
	- Medical Equipment	EN 60601-1 IEC 60601-1 ANSI/AAMI ES 60601-1
	- Power Transformers	2 x MOPP (Means Of Patient Protection) IEC 61558-1 IEC 61558-2-16
	- Certification Documents	www.tracopower.com/overview/tpp15a-d
Protection Class	Class II Prepared: Reinforced Insulation	
Pollution Degree	PD 2	
Over Voltage Category	OVC II	

EMC Specifications

EMC Emissions	- Conducted Emissions	EN 60601-1-2 edition 4 (Medical Devices) EN 55011 class B (internal filter) EN 55014-1 EN 55032 class B (internal filter) FCC Part 15, class B FCC Part 18, class B
	- Radiated Emissions	EN 55011 class B (internal filter) EN 55014-1 EN 55032 class B (internal filter) FCC Part 15, class B FCC Part 18, class B
	- Harmonic Current Emissions	EN 61000-3-2, class A
	- Voltage Fluctuations & Flicker	EN 61000-3-3
	EMC Immunity	EN 55024 (IT Equipment) EN 60601-1-2 edition 4 (Medical Devices) EN 55014-2 (Household Appliances Tools)
- Electrostatic Discharge	Air: EN 61000-4-2, ±15 kV, perf. criteria A Contact: EN 61000-4-2, ±8 kV, perf. criteria A EN 61000-4-3, 20 V/m, perf. criteria A EN 61000-4-4, ±2 kV, perf. criteria A	
- RF Electromagnetic Field	L to L: EN 61000-4-5, ±1 kV, perf. criteria A	
- EFT (Burst)	EN 61000-4-6, 20 Vrms, perf. criteria A	
- Surge	EN 61000-4-8, 30 A/m, perf. criteria A	
- Conducted RF Disturbances	230 VAC / 50 Hz: EN 61000-4-11 30%, 25 periods, perf. criteria A 60%, 1 period, perf. criteria A >95%, 1 period, perf. criteria A >95%, 250 periods, perf. criteria A	
- PF Magnetic Field	115 VAC / 60 Hz: EN 61000-4-11 30%, 25 periods, perf. criteria A 60%, 1 period, perf. criteria A >95%, 1 period, perf. criteria A >95%, 250 periods, perf. criteria A	
- Voltage Dips & Interruptions		

General Specifications

Relative Humidity	95% max. (non condensing)	
Temperature Ranges	- Operating Temperature	-40°C to +85°C
	- Storage Temperature	-40°C to +85°C

All specifications valid at nominal input voltage, full load and +25°C after warm-up time unless otherwise stated.

Power Derating	- High Temperature - Low Input Voltage	see application note www.tracopower.com/overview/tpp15a-d 4 %/V below 90 VAC
Cooling System		Natural convection (20 LFM)
Altitude During Operation		5'000 m max.
Switching Frequency		75 - 95 kHz (PWM)
Insulation System		Reinforced Insulation
Working Voltage (rated)		250 VAC
Isolation Test Voltage	- Input to Output, 60 s - Input to Case or PE, 60 s - Output to Case or PE, 60 s	5'657 VDC 2'121 VDC 2'121 VDC
Creepage	- Input to Output	8 mm min.
Clearance	- Input to Output	8 mm min.
Isolation Resistance	- Input to Output, 500 VDC	100 MOhm min.
Leakage Current (264 VAC)	- Touch Current	75 µA max.
Reliability	- Calculated MTBF	3'100'000 h (MIL-HDBK-217F, ground benign)
Environment	- Vibration - Mechanical Shock	IEC 60068-2-6 IEC 60068-2-27
Connection Type		THD (Through-Hole Device)
Weight		16.5 g
Environmental Compliance	- Reach - RoHS	www.tracopower.com/info/reach-declaration.pdf www.tracopower.com/info/rohs-declaration.pdf

Supporting Documents

Overview Link (for additional Documents)

www.tracopower.com/overview/tpp15a-d

All specifications valid at nominal input voltage, full load and +25°C after warm-up time unless otherwise stated.

Outline Dimensions

12, 15, 24, 36, and 48 VDC models - without heatsink

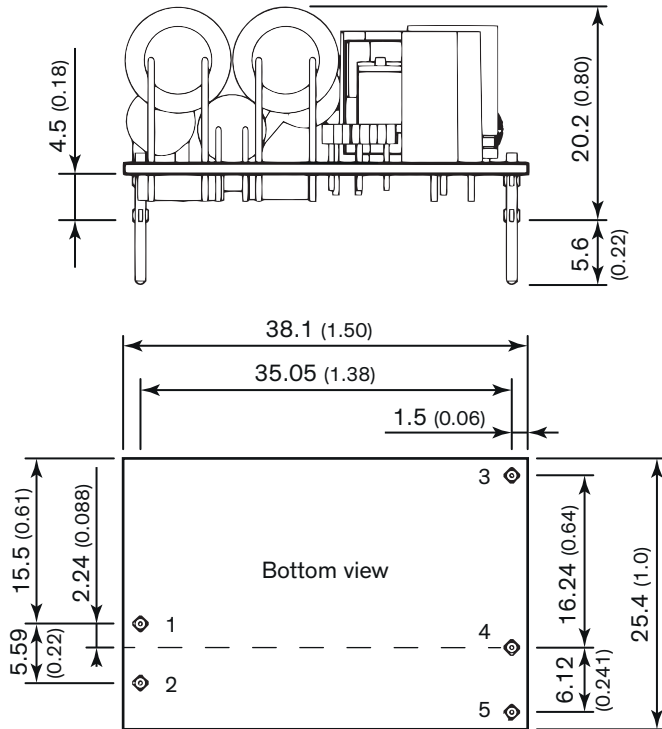

PCB Pinout	
Pin	Function
1	Neutral
2	Line
3	Trim
4	-Vout
5	+Vout

Print thickness: 1.0 mm (0.04 inch)
 Pin diameter: 1.0 mm (0.04 inch)

Dimension in mm, () = inch
 Tolerances: x.x ±0.50 (±0.02)
 x.xx ±0.25 (±0.01)
 Pin pitch tolerance: ±0.25 (±0.010)
 Pin dimension tolerance: ±0.10 (±0.004)

All specifications valid at nominal input voltage, full load and +25°C after warm-up time unless otherwise stated.

3.3, 5, and 9 VDC models - with heatsink

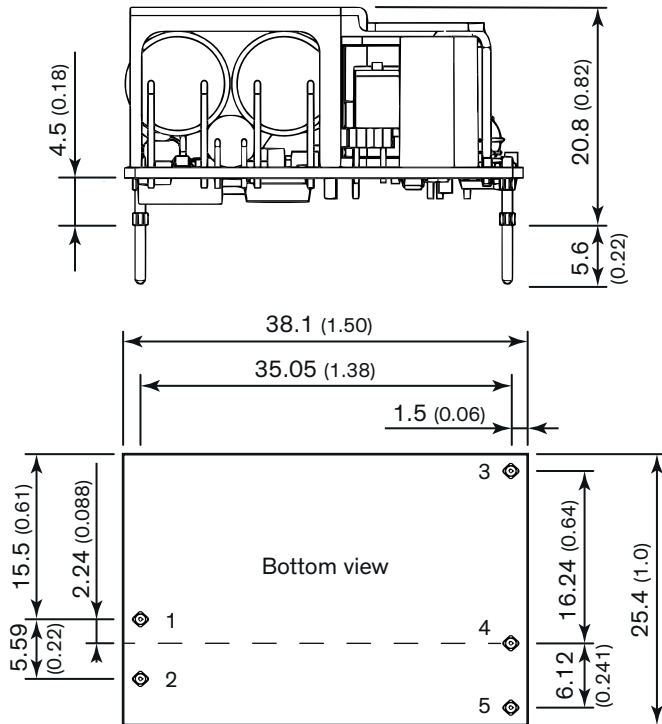

PCB Pinout	
Pin	Function
1	Neutral
2	Line
3	Trim
4	-Vout
5	+Vout

Print thickness: 1.0 mm (0.04 inch)
Pin diameter: 1.0 mm (0.04 inch)

Dimension in mm, () = inch
Tolerances: x.x ± 0.50 (± 0.02)
 x.xx ± 0.25 (± 0.01)
Pin pitch tolerance: ± 0.25 (± 0.010)
Pin dimension tolerance: ± 0.10 (± 0.004)

Компания «Океан Электроники» предлагает заключение долгосрочных отношений при поставках импортных электронных компонентов на взаимовыгодных условиях!

Наши преимущества:

- Поставка оригинальных импортных электронных компонентов напрямую с производств Америки, Европы и Азии, а так же с крупнейших складов мира;
- Широкая линейка поставок активных и пассивных импортных электронных компонентов (более 30 млн. наименований);
- Поставка сложных, дефицитных, либо снятых с производства позиций;
- Оперативные сроки поставки под заказ (от 5 рабочих дней);
- Экспресс доставка в любую точку России;
- Помощь Конструкторского Отдела и консультации квалифицированных инженеров;
- Техническая поддержка проекта, помощь в подборе аналогов, поставка прототипов;
- Поставка электронных компонентов под контролем ВП;
- Система менеджмента качества сертифицирована по Международному стандарту ISO 9001;
- При необходимости вся продукция военного и аэрокосмического назначения проходит испытания и сертификацию в лаборатории (по согласованию с заказчиком);
- Поставка специализированных компонентов военного и аэрокосмического уровня качества (Xilinx, Altera, Analog Devices, Intersil, Interpoint, Microsemi, Actel, Aeroflex, Peregrine, VPT, Syfer, Eurofarad, Texas Instruments, MS Kennedy, Miteq, Cobham, E2V, MA-COM, Hittite, Mini-Circuits, General Dynamics и др.);

Компания «Океан Электроники» является официальным дистрибьютором и эксклюзивным представителем в России одного из крупнейших производителей разъемов военного и аэрокосмического назначения «JONHON», а так же официальным дистрибьютором и эксклюзивным представителем в России производителя высокотехнологичных и надежных решений для передачи СВЧ сигналов «FORSTAR».



JONHON

«JONHON» (основан в 1970 г.)

Разъемы специального, военного и аэрокосмического назначения:

(Применяются в военной, авиационной, аэрокосмической, морской, железнодорожной, горно- и нефтедобывающей отраслях промышленности)

«FORSTAR» (основан в 1998 г.)

ВЧ соединители, коаксиальные кабели, кабельные сборки и микроволновые компоненты:

(Применяются в телекоммуникациях гражданского и специального назначения, в средствах связи, РЛС, а так же военной, авиационной и аэрокосмической отраслях промышленности).



Телефон: 8 (812) 309-75-97 (многоканальный)

Факс: 8 (812) 320-03-32

Электронная почта: ocean@oceanchips.ru

Web: <http://oceanchips.ru/>

Адрес: 198099, г. Санкт-Петербург, ул. Калинина, д. 2, корп. 4, лит. А