

## Si8920ISO-EVB USER'S GUIDE

### Description

This document describes the operation of the Si8920ISO-EVB.

### Kit Contents

- The Si8920ISO Evaluation Kit contains the following items:
- Si8920ISO-EVB.
- Si8920BC-IP installed on the evaluation board.

### Si8920ISO-EVB Overview

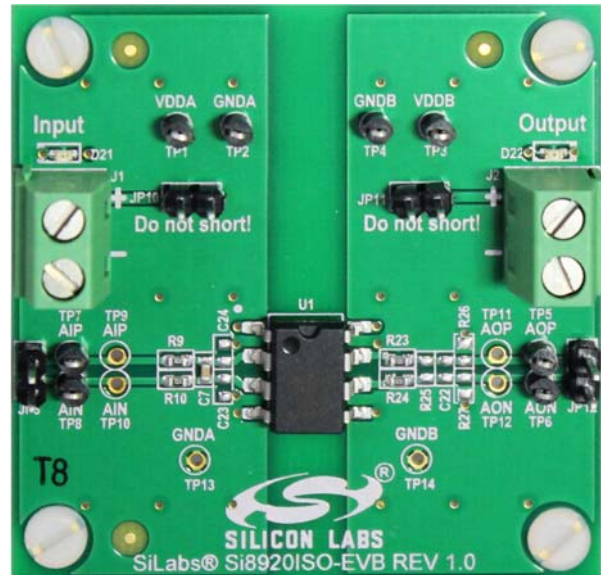

## 1. Hardware Overview and Setup

### 1.1. Connecting to the EVB

Power the EVB by applying isolated 3.0 to 5.5 V<sub>DC</sub> supplies to terminal blocks J1 and J2. LEDs D21 and D22 will light up. Use separate test points TP1, TP2, TP3, and TP4 for observing VDDA, GNDA, VDDB, and GNDB, respectively.

**Note:** DO NOT place jumpers across JP10, JP11, or JP12. These are redundant test points for VDDA, VDDB, and AOP/AON, respectively.

There are three connection points for applying and observing differential signals to the inputs of Si8920:

1. Through a two conductor ribbon cable to 2x1 header JP8.
2. Clipping wires to test points TP7 and TP8.
3. Soldering wires directly to through holes located at TP9 and TP10.

The same connector options are available for observing and taking the output signals off circuit board:

1. Through a two conductor ribbon cable at 2x1 header JP12.
2. Clipping wires to test points TP5 and TP6.
3. Soldering wires directly through holes located at TP11 and TP12.

### 1.2. Driving Si8920 Inputs

Drive the inputs with a low impedance source. The Si8920 has a typical input impedance of 37.2 k $\Omega$ . A high source impedance will affect the gain error of the amplifier. The maximum specified differential voltage is 200 mV and the common mode must be within -250 mV to 1 V with respect to GNDA.

**Note:** When driving inputs from a single-ended source, short the unused input to GNDA. If driving AIP input, install 0  $\Omega$  resistor across C23 pads. If driving AIN input, install a 0  $\Omega$  resistor across C24 pads.

## 1.3. Input Configuration

To measure input offset, install a jumper (not provided) at JP8 to short AIP and AIN together, and measure the difference voltage between AOP and AON.

Si8920 has a channel bandwidth of approximately 750 kHz. R9-C7-R10 are populated providing low pass filtering with cutoff frequency of approximately 400 kHz. If a different cutoff frequency is desired, replace C7 per Table 1. If it is necessary to replace R9 and R10 for a specific cutoff frequency, ensure that  $R9 = R10 < 33 \Omega$ .

**Table 1. Input Filter Cutoff Frequency for Common Capacitor Values with  $R9 = R10 = 20 \Omega$**

C7 (nF)	Cutoff Frequency (kHz)
10*	398
15	265
22	181
33	121
47	85
*Note: Installed value.	

Si8920 has excellent immunity to common mode transients. This EVB provides provisions for capacitors C23 and C24 (not populated) between each input pin and GNDA. Placing a small capacitor at C23 and C24 can assist with charge swapping between the inputs and GNDA during common mode transients. However, any mismatch between C23 and C24 will result as a gain error at the output.

## 1.4. Observing Si8920 Outputs

Use a differential probe when observing the output using an oscilloscope. Most differential oscilloscope probes will connect to the 2x1 headers JP12 without adapters. If only single-ended oscilloscope probes are available, use two and set oscilloscope to subtract the two channels as one channel will only show half of the output.

## 1.5. Output Configuration

By default, R23 and R24 are populated with 0  $\Omega$  resistors that pass the output signal to the output connectors. If low pass filtering at the output is required, replace R23 and R24 and populate C22.

R25 can be populated to measure the differential output drive strength. R26 and R27 can be populated to measure the common mode drive strength to GNDB.

**Table 2. Test Point Descriptions**

Test Point	Description	Reference
TP1	VDDA	GNDA
TP2	GNDA	N/A
TP3	VDDDB	GNDB
TP4	GNDB	N/A
TP5	AOP	GNDB
TP6	AON	GNDB
TP7	AIP	GNDA
TP8	AIN	GNDA
TP13	GNDA	N/A
TP14	GNDB	N/A

**Table 3. Jumper Descriptions**

Jumper	PIN 1	PIN 2	Default Position	Description
JP8	AIN	AIP	Not Installed	Analog Input Connector, Short to Measure Offset
JP10	VDDA	GNDA	Not Installed	<b>DO NOT SHORT</b> – test points only
JP11	VDDDB	GNDB	Not Installed	<b>DO NOT SHORT</b> – test points only
JP12	AON	AOP	Not Installed	<b>DO NOT SHORT</b> – test points only

## 2. Si8920ISO-EVB Schematics

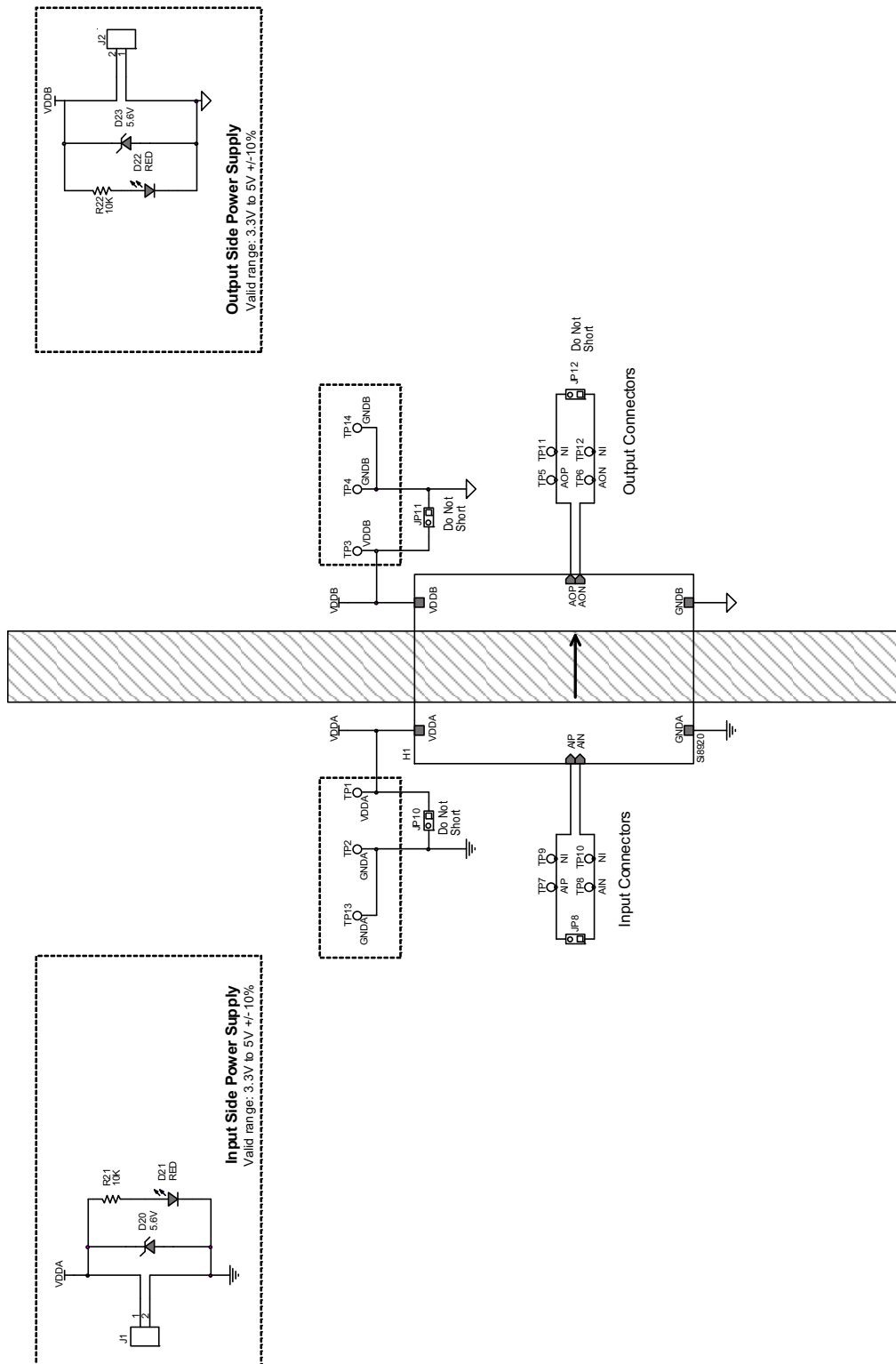

Figure 1. Si8920ISO-EVB Schematic (1 of 2)

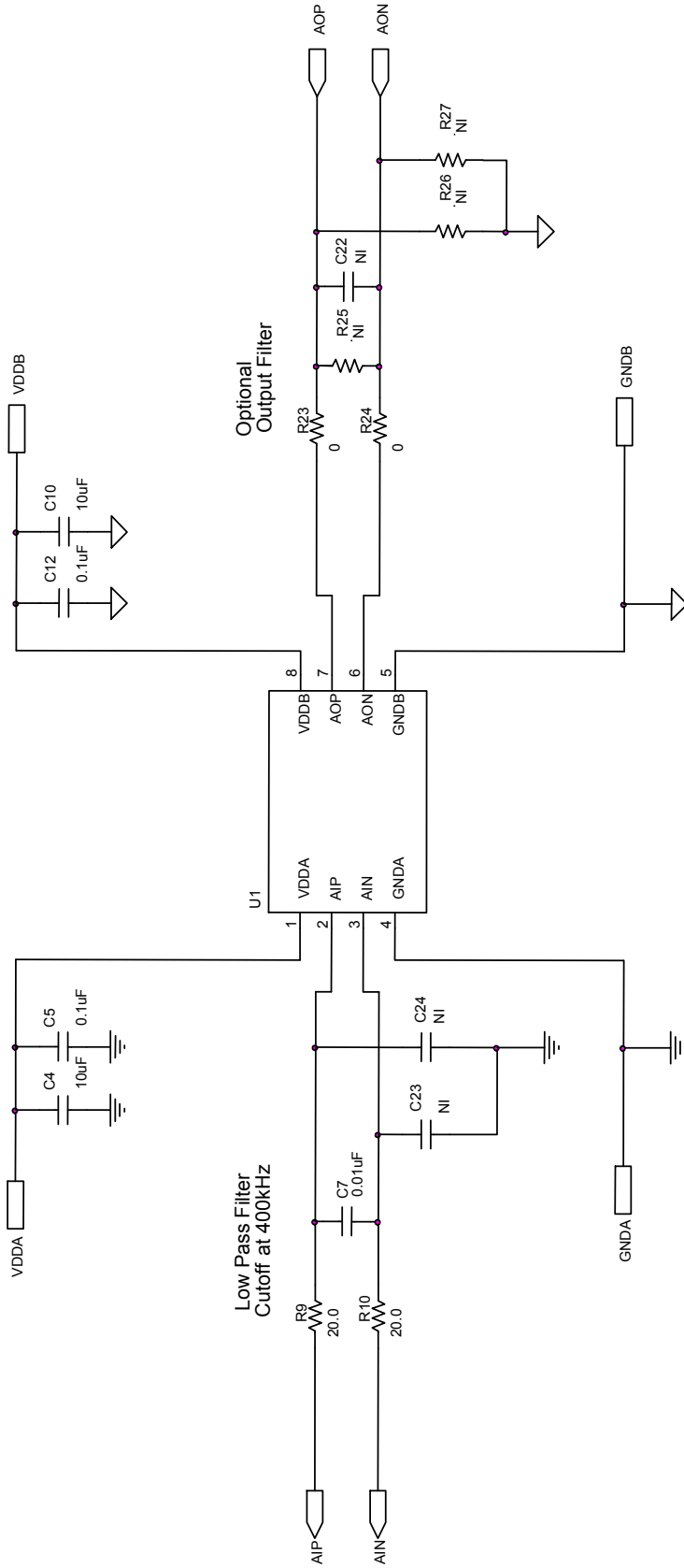
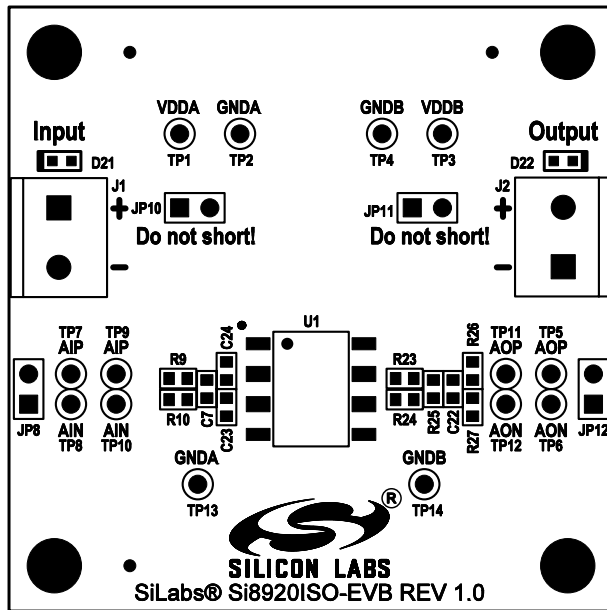
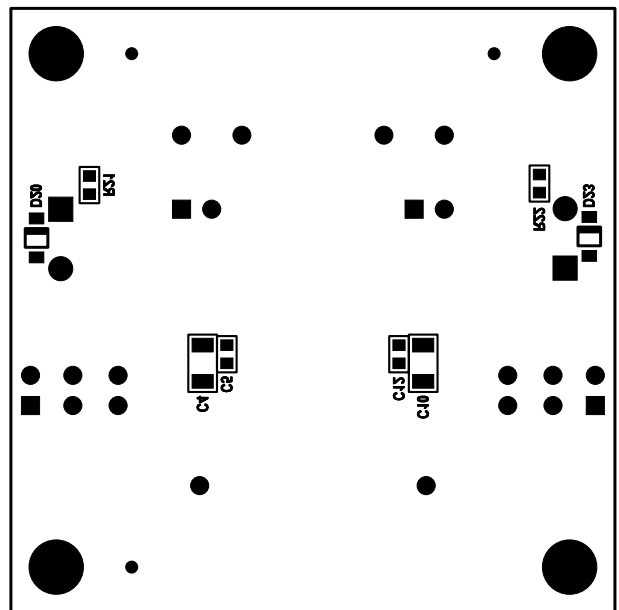

Figure 2. Si8920ISO-EVB Schematic (2 of 2)

## 3. Si8920ISO-EVB Layout



Top Silkscreen



Bottom Silkscreen

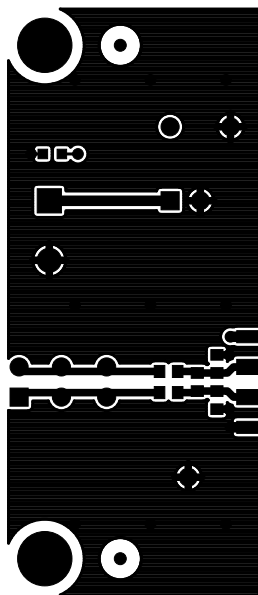

Top

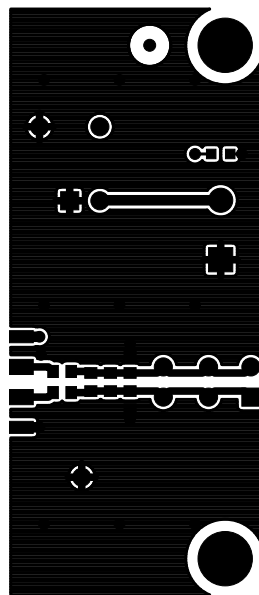

Bottom

Figure 3. Si8920ISO-EVB Layout

# Si8920ISO-EVB

## 4. Bill of Materials

Table 4. Si8920ISO-EVB Bill of Materials

Part Reference	Description	Manufacturer	Manufacturer Part Number
C4, C10	CAP, 10 $\mu$ F, 10 V, $\pm$ 20%, X7R, 1206	Venkel	C1206X7R100-106M
C5, C12	CAP, 0.1 $\mu$ F, 10 V, $\pm$ 10%, X7R, 0603	Venkel	C0603X7R100-104K
C7	CAP, 0.01 $\mu$ F, 16 V, $\pm$ 10%, X7R, 0603	Venkel	C0603X7R160-103K
D20, D23	DIO, ZENER, 28 V, 500 mW, SOD123	On Semi	MMSZ5255BT1G
D21, D22	LED, RED, 631 nM, 20 mA, 2 V, 54mcd, 0603	Lite-On	LTST-C190KRKT
J1, J2	CONN, TERM BLOCK 2POS, 5MM PCB	Phoenix Contact	1729018
JP8, JP10, JP11, JP12	Header, 2x1, 0.1" pitch, Tin Plated	Samtec	TSW-102-07-T-S
MH1, MH2, MH3, MH4	HDW, Screw, 4-40 x 1/4" Pan Head, Slotted, Nylon	Richco Plastic Co	NSS-4-4-01
R9, R10	RES, 20.0 $\Omega$ , 1/10 W, $\pm$ 1%, ThickFilm, 0603	Venkel	CR0603-10W-20R0F
R21, R22	RES, 10 K, 1/10 W, $\pm$ 5%, ThickFilm, 0603	Venkel	CR0603-10W-103J
R23, R24	RES, 0 $\Omega$ , 1A, ThickFilm, 0603	Venkel	CR0603-16W-000
SO1, SO2, SO3, SO4	HDW, STANDOFF, 1/4" HEX, 4-40x3/4", NYLON	Keystone	1902D
TP1, TP2, TP3, TP4, TP5, TP6, TP7, TP8	TESTPOINT, BLACK, PTH	Kobiconn	151-203-RC
U1	IC, ISOLATED AMPLIFIER FOR CURRENT SHUNT MEASUREMENT, 8PIN SMD GULL WING	Silicon Labs	Si8920BC-IP



## 5. Ordering Guide

Table 5. Si8920ISO-EVB Ordering Guide

Ordering Part Number (OPN)	Description
Si8920ISO-KIT	Si8920 Analog isolator evaluation board kit

## CONTACT INFORMATION

### **Silicon Laboratories Inc.**

400 West Cesar Chavez

Austin, TX 78701

Tel: 1+(512) 416-8500

Fax: 1+(512) 416-9669

Toll Free: 1+(877) 444-3032

Please visit the Silicon Labs Technical Support web page:

<https://www.siliconlabs.com/support/pages/contacttechnicalsupport.aspx>

and register to submit a technical support request.

### **Patent Notice**

Silicon Labs invests in research and development to help our customers differentiate in the market with innovative low-power, small size, analog-intensive mixed-signal solutions. Silicon Labs' extensive patent portfolio is a testament to our unique approach and world-class engineering team.

The information in this document is believed to be accurate in all respects at the time of publication but is subject to change without notice. Silicon Laboratories assumes no responsibility for errors and omissions, and disclaims responsibility for any consequences resulting from the use of information included herein. Additionally, Silicon Laboratories assumes no responsibility for the functioning of undescribed features or parameters. Silicon Laboratories reserves the right to make changes without further notice. Silicon Laboratories makes no warranty, representation or guarantee regarding the suitability of its products for any particular purpose, nor does Silicon Laboratories assume any liability arising out of the application or use of any product or circuit, and specifically disclaims any and all liability, including without limitation consequential or incidental damages. Silicon Laboratories products are not designed, intended, or authorized for use in applications intended to support or sustain life, or for any other application in which the failure of the Silicon Laboratories product could create a situation where personal injury or death may occur. Should Buyer purchase or use Silicon Laboratories products for any such unintended or unauthorized application, Buyer shall indemnify and hold Silicon Laboratories harmless against all claims and damages.

Silicon Laboratories and Silicon Labs are trademarks of Silicon Laboratories Inc.

Other products or brandnames mentioned herein are trademarks or registered trademarks of their respective holders.

Компания «Океан Электроники» предлагает заключение долгосрочных отношений при поставках импортных электронных компонентов на взаимовыгодных условиях!

Наши преимущества:

- Поставка оригинальных импортных электронных компонентов напрямую с производств Америки, Европы и Азии, а так же с крупнейших складов мира;
- Широкая линейка поставок активных и пассивных импортных электронных компонентов (более 30 млн. наименований);
- Поставка сложных, дефицитных, либо снятых с производства позиций;
- Оперативные сроки поставки под заказ (от 5 рабочих дней);
- Экспресс доставка в любую точку России;
- Помощь Конструкторского Отдела и консультации квалифицированных инженеров;
- Техническая поддержка проекта, помощь в подборе аналогов, поставка прототипов;
- Поставка электронных компонентов под контролем ВП;
- Система менеджмента качества сертифицирована по Международному стандарту ISO 9001;
- При необходимости вся продукция военного и аэрокосмического назначения проходит испытания и сертификацию в лаборатории (по согласованию с заказчиком);
- Поставка специализированных компонентов военного и аэрокосмического уровня качества (Xilinx, Altera, Analog Devices, Intersil, Interpoint, Microsemi, Actel, Aeroflex, Peregrine, VPT, Syfer, Eurofarad, Texas Instruments, MS Kennedy, Miteq, Cobham, E2V, MA-COM, Hittite, Mini-Circuits, General Dynamics и др.);

Компания «Океан Электроники» является официальным дистрибьютором и эксклюзивным представителем в России одного из крупнейших производителей разъемов военного и аэрокосмического назначения «JONHON», а так же официальным дистрибьютором и эксклюзивным представителем в России производителя высокотехнологичных и надежных решений для передачи СВЧ сигналов «FORSTAR».



## JONHON

«JONHON» (основан в 1970 г.)

Разъемы специального, военного и аэрокосмического назначения:

(Применяются в военной, авиационной, аэрокосмической, морской, железнодорожной, горно- и нефтедобывающей отраслях промышленности)

«FORSTAR» (основан в 1998 г.)

ВЧ соединители, коаксиальные кабели, кабельные сборки и микроволновые компоненты:

(Применяются в телекоммуникациях гражданского и специального назначения, в средствах связи, РЛС, а так же военной, авиационной и аэрокосмической отраслях промышленности).



Телефон: 8 (812) 309-75-97 (многоканальный)

Факс: 8 (812) 320-03-32

Электронная почта: [ocean@oceanchips.ru](mailto:ocean@oceanchips.ru)

Web: <http://oceanchips.ru/>

Адрес: 198099, г. Санкт-Петербург, ул. Калинина, д. 2, корп. 4, лит. А