

## PWM, PWM/PFM Switching Step-Up & Down DC/DC Converter Controller ICs

Green Operation Compatible

### GENERAL DESCRIPTION

The XC9301/XC9302 series are step-up/down DC/DC converter controller ICs with fast, low ON resistance drivers built-in. A versatile, large output current, step-up/down DC/DC converter can be realized using only 4 type of basic external components two transistors, one inductor, two diodes and capacitors.

Output voltage is selectable in 0.1V increments within a 2.4V ~ 6.0V ( $\pm 2.5\%$  accuracy) range and switching frequency is set at 180kHz or 300kHz.

The XC9302 series switches from PWM to PFM control during light loads and the series offers high efficiencies from light loads through to large output currents.

Soft-start time is internally set to 10ms which offers protection against inrush currents when the power is turned on and also against voltage overshoot.

During shutdown (CE pin = L), consumption current can be reduced to as little as 0.5  $\mu$  A or less.

### APPLICATIONS

- Mobile phones
- PDA's
- Palmtop computers
- Portable audio equipment
- Various power supplies

### FEATURES

- Input Voltage Range** : 2.0V ~ 10V
- Output Voltage Range** : 2.4V ~ 6.0V ( $\pm 2.5\%$  accuracy)  
(selectable in 0.1V increments)
- Oscillation Frequency** : 180kHz, 300kHz  
( $\pm 15\%$  accuracy)
- Output Current** : 250mA ( $V_{IN}=2.4V$ ,  $V_{OUT}=3.3V$ )
- Efficiency** : 81%(TYP.) @  $V_{OUT}=5.0V$ ,  
78%(TYP.) @  $V_{OUT}=3.3V$
- Stand-By** :  $I_{STB} = 0.5 \mu A$  (MAX.)
- Maximum Duty Cycle** : 85%(TYP.)
- Package** : SOT-25
- Environmentally Friendly**: EU RoHS Compliant, Pb Free

### TYPICAL APPLICATION CIRCUIT

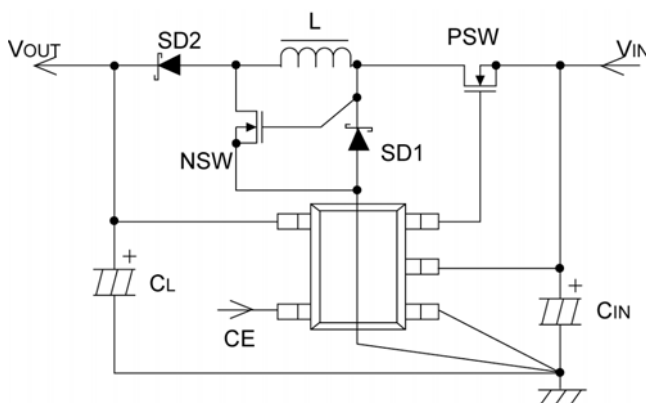

### TYPICAL PERFORMANCE CHARACTERISTICS

XC9302A502 (180kHz,  $V_{OUT}=5.0V$ )

Efficiency vs. Output Current

PSW=XP162A12A6PR, CL=47  $\mu$  F ((MCE series, Tantalum)  $\times$  2,  
NSW=XP161A1265PR, CIN=220  $\mu$  F (Electrolytic, PJ type), SD=U2FWJ44N, R<sub>DD</sub>=10  $\Omega$ ,  
L=22  $\mu$  H (CR54), CDD=47  $\mu$  F (MCE series, Tantalum)

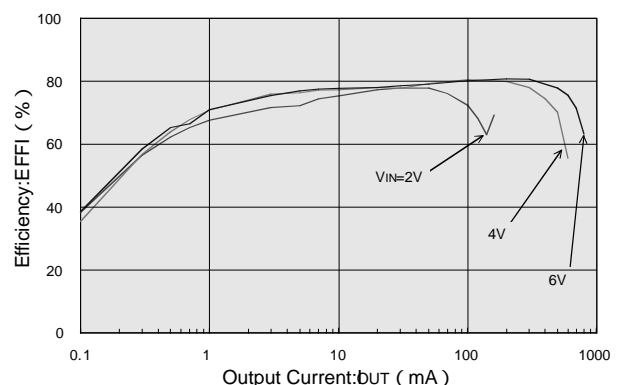

## PIN CONFIGURATION

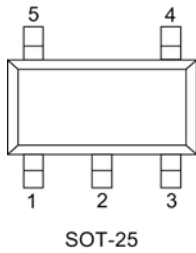

## PIN ASSIGNMENT

PIN NUMBER	PIN NAME	FUNCTION
1	GND	Ground
2	VDD	Power Supply
3	EXT/	External Tr. Drive
4	VOUT	Output Voltage Monitor
5	CE	Chip Enable

## PRODUCT CLASSIFICATION

### Ordering Information

XC9301 - <sup>(\*)</sup>: PWM control  
 XC9302 - <sup>(\*)</sup>: PWM/PFM switching control

DESIGNATOR	DESCRIPTION	SYMBOL	DESCRIPTION
	Standard	A	Fixed
	Output Voltage	20~60	e.g. VOUT=3.0V =3, =0, VOUT=5.3V =5, =3
	Oscillation Frequency	2	180kHz
		3	300kHz
-	Packages Taping Type <sup>(*)</sup>	MR-G	SOT-25

<sup>(\*)</sup> The "-G" suffix indicates that the products are Halogen and Antimony free as well as being fully RoHS compliant.

<sup>(\*)</sup> The device orientation is fixed in its embossed tape pocket. For reverse orientation, please contact your local Torex sales office or representative. (Standard orientation: R- , Reverse orientation: L- )

## BLOCK DIAGRAM

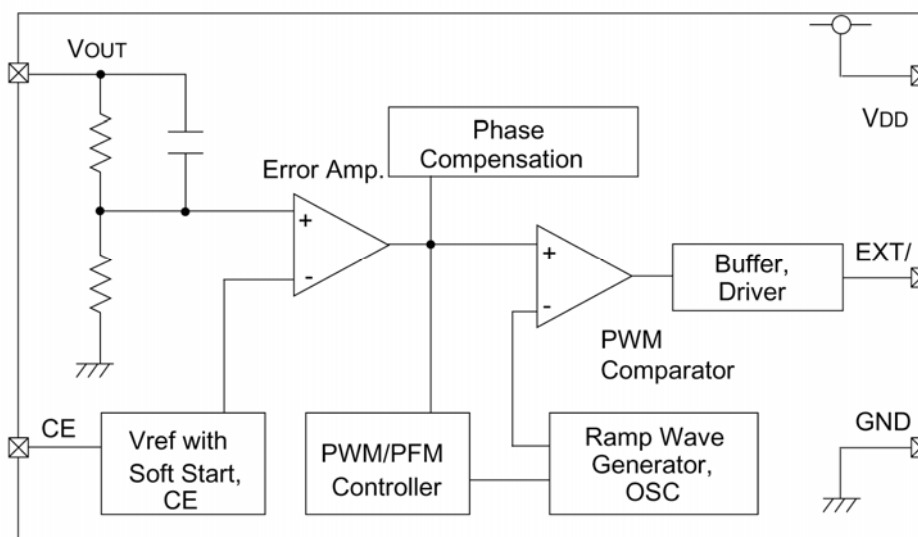

## ABSOLUTE MAXIMUM RATINGS

Ta = 25

PARAMETER	SYMBOL	RATINGS	UNITS
VDD Pin Voltage	VDD	-0.3 ~ 12.0	V
VOUT Pin Voltage	VOUT	-0.3 ~ 12.0	V
CE Pin Voltage	VCE	-0.3 ~ 12.0	V
EXT/ Pin Voltage	VEXT/	-0.3 ~ VDD+0.3	V
EXT/ Pin Current	IEXT/	± 100	mA
Power Dissipation	Pd	150	mW
Operating Temperature Range	Topr	-40 ~ +85	
Storage Temperature Range	Tstg	-40 ~ +125	

## ELECTRICAL CHARACTERISTICS

XC9301x332MR, XC9302x332MR

(V<sub>OUT</sub>=3.3V, FOSC=180kHz)

T<sub>a</sub>=25

PARAMETER	SYMBOL	CONDITIONS	MIN.	TYP.	MAX.	UNITS
Output Voltage	V <sub>OUT</sub>		3.218	3.300	3.383	V
Supply Voltage	V <sub>DD</sub>		2.0	-	10.0	V
Supply Current 1	I <sub>DD1</sub>	V <sub>OUT</sub> =CE: Setting output voltage × 0.95 applied	-	80	140	μA
Supply Current 2	I <sub>DD2</sub>	V <sub>OUT</sub> =CE: Setting output voltage + 0.5 applied	-	15	26	μA
Stand-By Current	I <sub>STB</sub>	V <sub>OUT</sub> : Setting output voltage × 0.95 applied, CE=0V	-	-	0.5	μA
Oscillation Frequency	FOSC	V <sub>DD</sub> =V <sub>OUT</sub> =CE: Setting output voltage × 0.95 applied	153	180	207	kHz
Maximum Duty Ratio	MAXDTY	V <sub>DD</sub> =V <sub>OUT</sub> =CE: Setting output voltage × 0.95 applied	78	85	92	%
PFM Duty Ratio <sup>(*)1</sup>	PFMDTY	No Load	15	25	35	%
Efficiency <sup>(*)2</sup>	EFFI	V <sub>DD</sub> =V <sub>IN</sub> =CE: Setting output voltage × 0.95 applied	-	78	-	%
Soft-Start Time	T <sub>SS</sub>		5.0	10.0	20.0	ms
CE 'H' Voltage	V <sub>CEH</sub>	V <sub>OUT</sub> : Setting output voltage × 0.95 applied	0.65	-	-	V
CE 'L' Voltage	V <sub>CEL</sub>	V <sub>OUT</sub> : Setting output voltage × 0.95 applied	-	-	0.20	V
EXT/ 'H' ON Resistance	R <sub>EXTBH</sub>	Same as I <sub>DD1</sub> , V <sub>EXT/</sub> = V <sub>OUT</sub> - 0.4V	-	29	43	
EXT/ 'L' ON Resistance	R <sub>EXTBL</sub>	Same as I <sub>DD1</sub> , V <sub>EXT/</sub> = 0.4V	-	19	27	

Test Conditions: Unless otherwise stated, V<sub>DD</sub> = 3.3V, I<sub>OUT</sub> = 130mA

NOTE: \*1: XC9302 series only

\*2: EFFI =  $\frac{(\text{output voltage}) \times (\text{output current})}{(\text{input voltage}) \times (\text{input current})} \times 100$

XC9301x333MR, XC9302x333MR

(V<sub>OUT</sub>=3.3V, FOSC=300kHz)

T<sub>a</sub>=25

PARAMETER	SYMBOL	CONDITIONS	MIN.	TYP.	MAX.	UNITS
Output Voltage	V <sub>OUT</sub>		3.218	3.300	3.383	V
Supply Voltage	V <sub>DD</sub>		2.0	-	10.0	V
Supply Current 1	I <sub>DD1</sub>	V <sub>OUT</sub> =CE: Setting output voltage × 0.95 applied	-	130	200	μA
Supply Current 2	I <sub>DD2</sub>	V <sub>OUT</sub> =CE: Setting output voltage + 0.5 applied	-	20	35	μA
Stand-By Current	I <sub>STB</sub>	V <sub>OUT</sub> : Setting output voltage × 0.95 applied, CE=0V	-	-	0.5	μA
Oscillation Frequency	FOSC	V <sub>DD</sub> =V <sub>OUT</sub> =CE: Setting output voltage × 0.95 applied	255	300	345	kHz
Max. Duty Ratio	MAXDTY	V <sub>DD</sub> =V <sub>OUT</sub> =CE: Setting output voltage × 0.95 applied	78	85	92	%
PFM Duty Ratio <sup>(*)1</sup>	PFMDTY	No Load	15	25	35	%
Efficiency <sup>(*)2</sup>	EFFI	V <sub>DD</sub> =V <sub>IN</sub> =CE: Setting output voltage × 0.95 applied	-	78	-	%
Soft-Start Time	T <sub>SS</sub>		5.0	10.0	20.0	ms
CE 'H' Voltage	V <sub>CEH</sub>	V <sub>OUT</sub> : Setting output voltage × 0.95 applied	0.65	-	-	V
CE 'L' Voltage	V <sub>CEL</sub>	V <sub>OUT</sub> : Setting output voltage × 0.95 applied	-	-	0.20	V
EXT/ 'H' ON Resistance	R <sub>EXTBH</sub>	Same as I <sub>DD1</sub> , V <sub>EXT/</sub> = V <sub>OUT</sub> - 0.4V	-	29	43	
EXT/ 'L' ON Resistance	R <sub>EXTBL</sub>	Same as I <sub>DD1</sub> , V <sub>EXT/</sub> = 0.4V	-	19	27	

Test Conditions: Unless otherwise stated, V<sub>DD</sub> = 3.3V, I<sub>OUT</sub> = 130mA

NOTE: \*1: XC9302 series only

\*2: EFFI =  $\frac{(\text{output voltage}) \times (\text{output current})}{(\text{input voltage}) \times (\text{input current})} \times 100$

## TYPICAL APPLICATION CIRCUIT

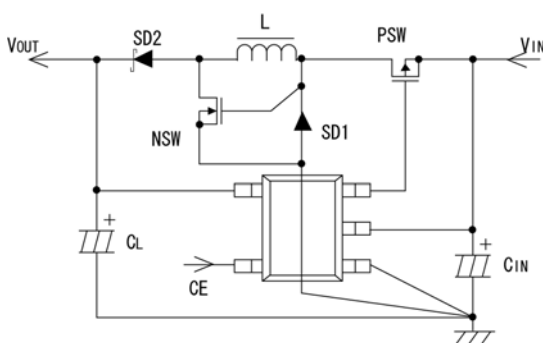

### External Components

PSW: XP162A12 (SOT-89, TOREX)

NSW: XP161A12 (SOT-89, TOREX)

L : 22 μH (CR54, SUMIDA)

SD : U2FWJ44N ( Schottky, TOSHIBA )

CL : 16V, 47 μ F×2 (Tantalum, MCE series, NICHICON )

CIN : 16V, 22 μ F (Tantalum, MCE series, NICHICON )

220 μ F (Electrolytic, NICHICON, PJ type)

## OPERATIONAL EXPLANATION

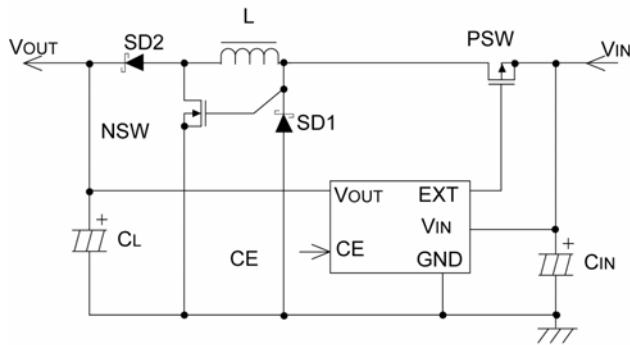

<Circuit Connection Example>

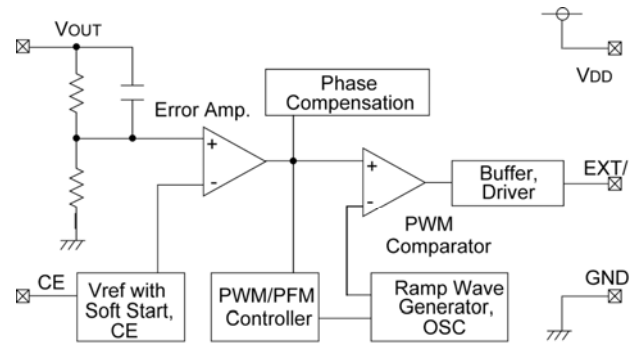

<Block Diagram>

The XC9301/9302 series are PWM (PWM/PFM switching) step-up/down DC/DC converter controller ICs. The XC9302 series switches to PFM operations during light loads and is very efficient over a wide range in relation to load. Further, the efficiency can be maintained over a wide input voltage range as both step-up & step-down operations are PWM controlled. Output voltage settings are laser trimmed.

### <ON TIME>

P-ch MOSFET (PSW) = ON, N-ch MOSFET (NSW) = ON: Current flows from  $V_{IN}$  via PSW, L, NSW, to GND: L is charged.

### <OFF TIME>

P-ch MOSFET (PSW) = OFF, N-ch MOSFET (NSW) = OFF: Current flows from GND via SD1, L, SD2, to  $V_{OUT}$ :  $V_{OUT}$  rises due to the charge stored at L.

By comparing  $V_{OUT}$  with the internal reference voltage, the ON TIME vs. OFF TIME ratio can be regulated & output stability can be protected.

### <Error Amp.>

The error amplifier is used as an output voltage monitor. It compares the reference voltage with the feedback from the voltage divided by the internal resistor. Should a voltage higher than the reference voltage be feedback, the output of the error amp will increase.

### <PWM Comparator>

The PWM comparator compares the output of the error amp with the ramp wave. When the voltage at the output of the error amp is low, the EXT/ pin will be low level (Switching ON time).

### <Ramp Wave Generator>

The ramp wave generator generates the switching frequency's ramp wave.

### <PWM / PFM Controller>

With the XC9302 series, control is automatically switched between PWM and PFM according to the size of the load.

### <Vref with Soft Start, CE>

The start up of the  $V_{ref}$  voltage at the error amp's input is gradual due to the internal capacitor and low current circuit. Because of this soft-start function, the operations of the error amp's 2 inputs are balanced and the EXT/ pin's ON TIME can be manipulated to produce longer ON times. Further, with the U.V.L.O. function, the signal will be such so as not to turn the MOSFET switch ON until any instability in the internal circuit stabilizes during soft-start time. Even in cases where input voltage is so low as to produce instability in the IC, the U.V.L.O. function will operate and the MOSFET switch will be turned OFF.

## OPERATIONAL EXPLANATION (Continued)

### Product Selection (Notes)

XC9301/02 series is a group of PFM controlled (XC9302 series switches from PWM to PFM control during light loads) step-up and down DC/DC converters. The series is highly efficient with a wide range of input voltage since its stepping-up and down operation is controlled by PWM movements. In general, there are several methods available for obtaining a stable output voltage at such times when input voltage is changing from being higher than the established output voltage to being lower than the established output voltage. Each method has its merits and demerits but is essential that a method, which provides the best results in terms of input and output under actual operating conditions. Below, two methods are highlighted and their respective performances in terms of efficiency are compared. This is an efficiency comparison of two ways, step-up DC/DC converter + VR and step-up & down DC/DC converter.

#### [Step-Up DC/DC Converter + VR] (XC6361/62)

Step-up mode (Input voltage < setting output voltage + 0.4V)

After input voltage has been stepped-up to setting output voltage + 0.4V by the step-up DC/DC converter, the output voltage will be regulated to the set value by the VR. (0.4V loss via the VR)

Step-down mode (Input voltage  $\geq$  setting output voltage + 0.4V)

After input voltage has been stepped-up to setting output voltage + 0.4V by the step-up DC/DC converter, the output voltage will be regulated to the set value by the VR. (Dropout voltage loss via the VR)

#### [Step-Up & Down DC/DC Converter] (XC9301/02)

Setting output voltage obtained as a result of the automatic switching operations of the IC regardless of the difference between input voltage and set output voltage.

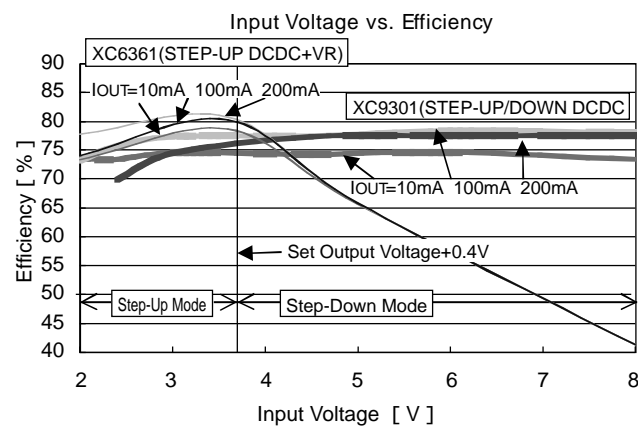

The above graph shows that over a wide input voltage range, the efficiency of the XC9301/02 is more or less constant. On the other hand, the efficiency of the XC6361/62 is clearly shown to decrease as input voltage increases. In step-down mode in particular, the efficiency of the XC9301/02 is much better than the XC6361/62. In applications that use either a standard dry 3 cell battery or a 2 cell lithium Ion battery to obtain an output of 3.3V, for example, the efficiency of the XC9301/02 series is again much better. Because the XC9301/02 series does not have a series regulator output, we recommend a test with samples for use in applications where ripple voltage is a problem.

### External Components Selection (Notes)

The performance of the DC/DC converter IC circuit is heavily reliant upon the performance of the surrounding circuitry and components. In particular, since the  $V_F$  voltage of the Schottky Diode used will have a direct effect upon efficiency, the smaller the diode, the better the efficiency obtainable. (Refer to the graph below)

It is also recommended that a switching MOSFET with a small ON resistance be used. With the XC9301/02, an ON resistance of 500m $\Omega$  or less is recommended.

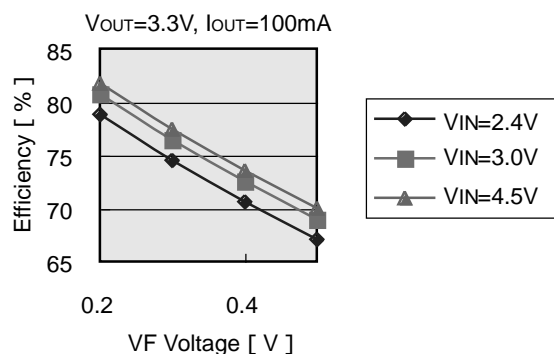

## OPERATIONAL EXPLANATION (Continued)

Demo Board Version 1.1

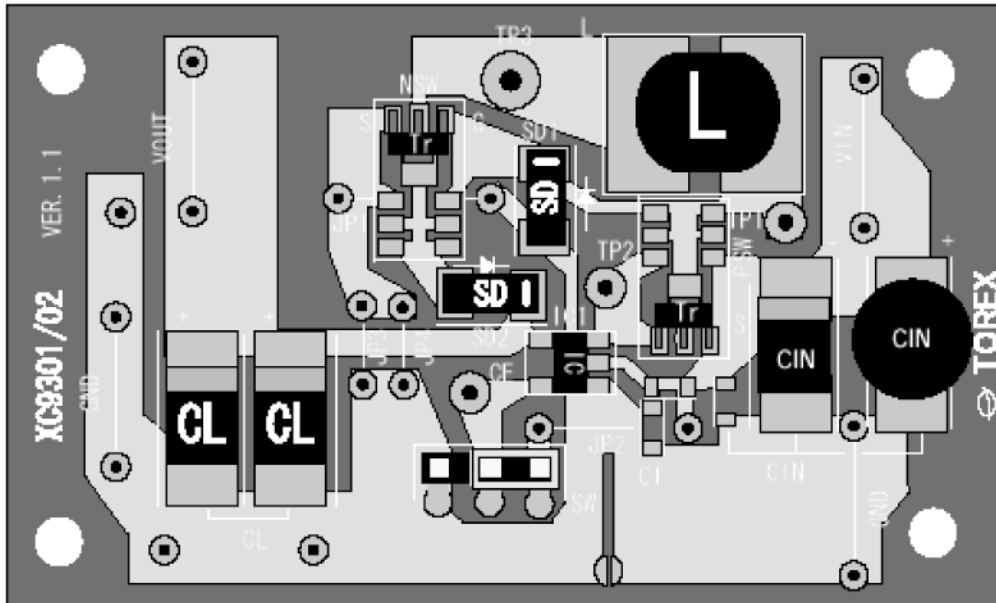

### External Components

- PSW : XP162A12 (SOT-89)
- NSW : XP161A12 (SOT-89)
- L : 22  $\mu$  H (CR54, SUMIDA)
- SD : U2FWJ44N (Schottky, TOSHIBA)
- CL : 16V, 47  $\mu$  F  $\times$  2 (Tantalum, MCE series, NICHICON)
- CIN : 16V, 22  $\mu$  F (Tantalum, MCE series, NICHICON)  
16V, 220  $\mu$  F (Electrolytic, NICHICON, PJ type)

### Demo Board Connection Layout

- suitable for SOT-23, SOT-89, CPH-6
- suitable for CR43 ~ CR105
- suitable for MA720, MA735, U2FWJ44N
- suitable for 1005 type ~ D2 Package

### <Jumper Settings>

JP3: Must be connected

JP2: To be connected if using SW (CE pin fixed to VIN)

\* Use tinned copper wire for the VIN pin, VOUT pin, GND pin, JP2, and JP3.

\* Connect test pins for the TP1, TP2, TP3, and CE.

### Note:

Oscillation may occur as a result of input voltage instability when the output current is large. At such times, we recommend that in place of the 220  $\mu$  F, PJ type capacitor, you connect R1 & C1 as shown in the diagram on the right hand side. (In case of demo boards version 1.1, cut the pattern wire of R1 connecting point, then connect R1.)

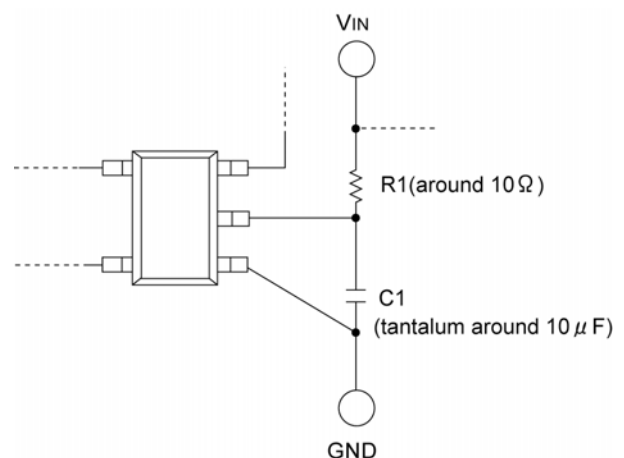

## TYPICAL PERFORMANCE CHARACTERISTICS

XC9302A332 (PWM/PFM switching control, 180kHz,  $V_{OUT}=3.3V$ )

(1) Output Voltage vs. Output Current ( $T_{opr}=25^\circ C$ )

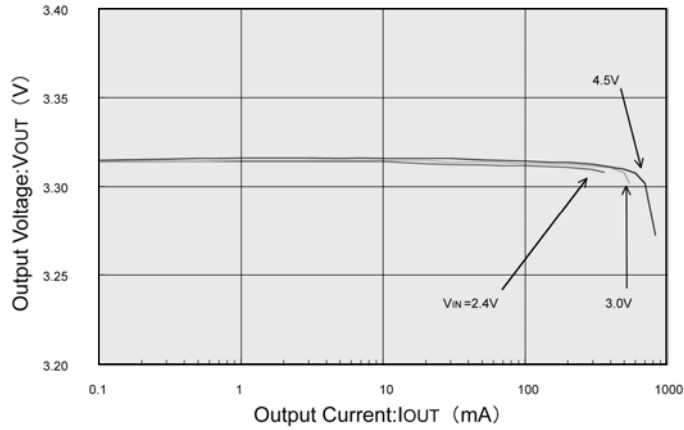

(2) Efficiency vs. Output Current ( $T_{opr}=25^\circ C$ )

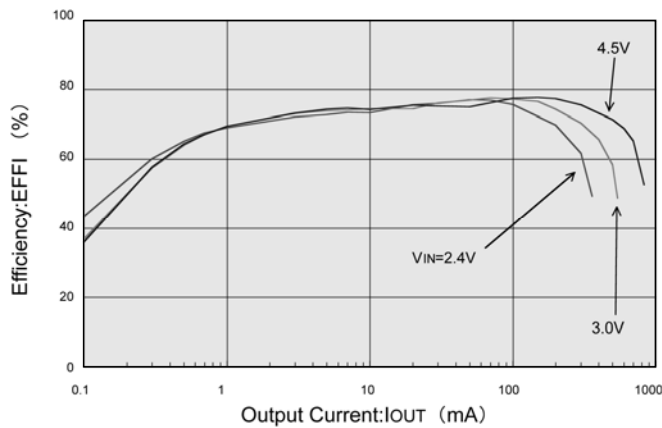

(3) Ripple Voltage vs. Output Current ( $T_{opr}=25^\circ C$ )

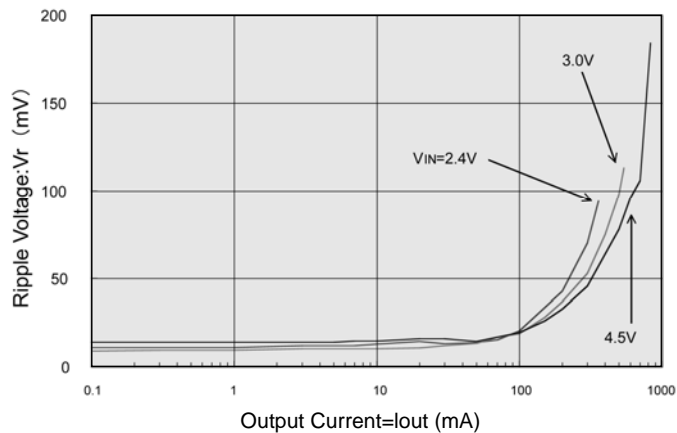

### External Components

PSW : XP162A12A6PR  
 NSW : XP161A1265PR  
 SD : U2FWJ44N  
 L : 22  $\mu H$  (CR54)

CL : 47  $\mu F$  (MCE series, Tantalum)  $\times 2$   
 CIN : 220  $\mu F$  (Electrolytic, PJ type)  
 R<sub>DD</sub> : 10  
 C<sub>DD</sub> : 47  $\mu F$  (MCE series, Tantalum)  
 V<sub>CE</sub>=V<sub>IN</sub>



## TYPICAL PERFORMANCE CHARACTERISTICS (Continued)

XC9302A332 (PWM/PFM switching control, 180kHz,  $V_{OUT}=3.3V$ ) (Continued)

(4) Load Transient Response ( $T_{opr}=25^\circ C$ )

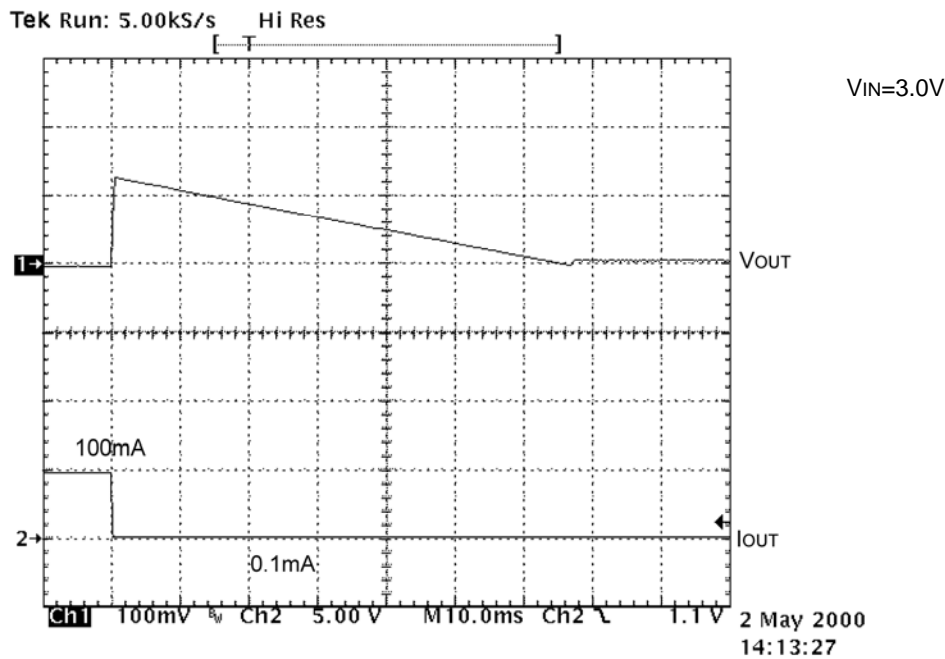
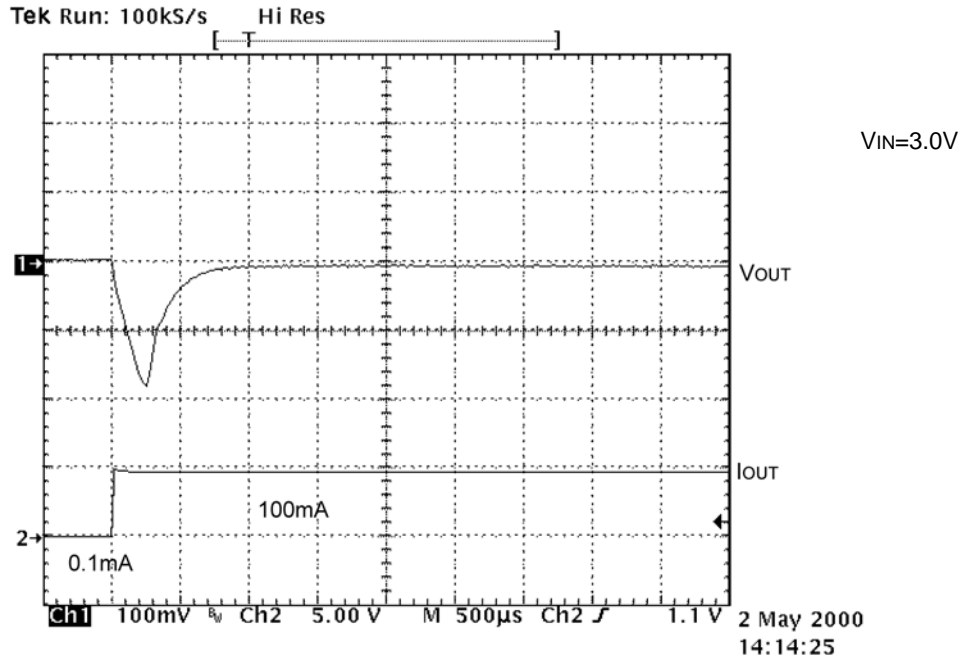

### External Components

PSW : XP162A12A6PR  
NSW : XP161A1265PR  
SD : U2FWJ44N  
L : 22  $\mu H$  (CR54)

CL : 47  $\mu F$  (MCE series, Tantalum)  $\times 2$   
CIN : 220  $\mu F$  (Electrolytic, PJ type)  
RDD : 10  
CDD : 47  $\mu F$  (MCE series, Tantalum)  
 $V_{CE}=V_{IN}$

## TYPICAL PERFORMANCE CHARACTERISTICS (Continued)

XC9302A502 (PWM/PFM switching control, 180kHz,  $V_{OUT}=5.0V$ )

(1) Output Voltage vs. Output Current ( $T_{opr}=25^\circ C$ )

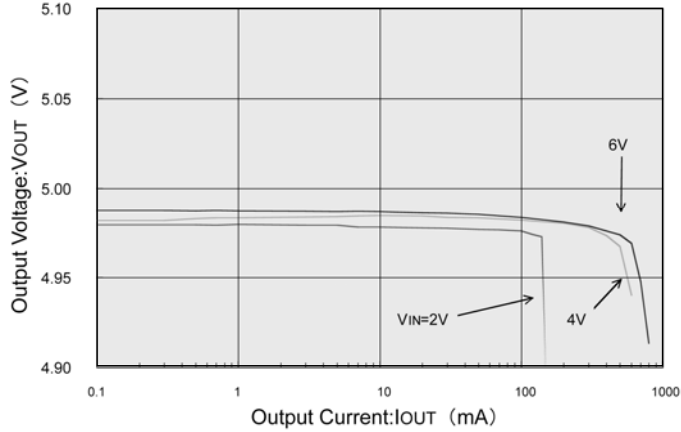

(2) Efficiency vs. Output Current ( $T_{opr}=25^\circ C$ )

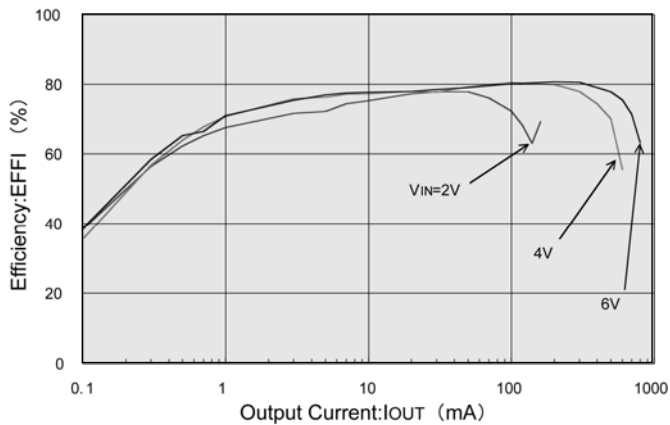

(3) Ripple Voltage vs. Output Current ( $T_{opr}=25^\circ C$ )

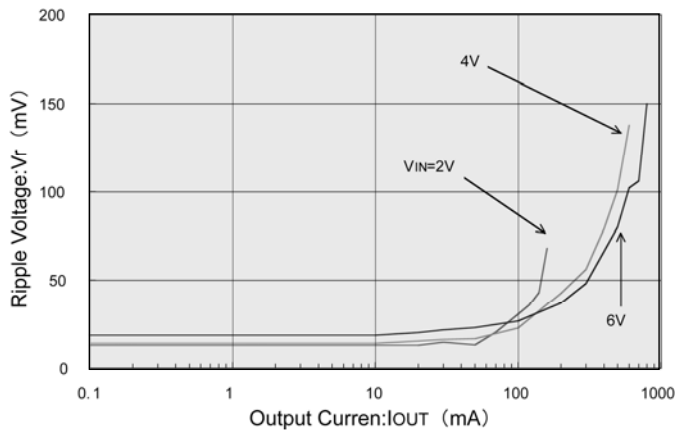

### External Components

PSW : XP162A12A6PR  
 NSW : XP161A1265PR  
 SD : U2FWJ44N  
 L : 22  $\mu H$  (CR54)

CL : 47  $\mu F$  (MCE series, Tantalum)  $\times 2$   
 CIN : 220  $\mu F$  (Electrolytic, PJ type)  
 RDD : 10  
 CDD : 47  $\mu F$  (MCE series, Tantalum)  
 VCE=VIN

## TYPICAL PERFORMANCE CHARACTERISTICS (Continued)

XC9302A502 (PWM/PFM switching control, 180kHz,  $V_{OUT}=5.0V$ ) (Continued)

(4) Load Transient Response ( $T_{opr}=25^\circ C$ )

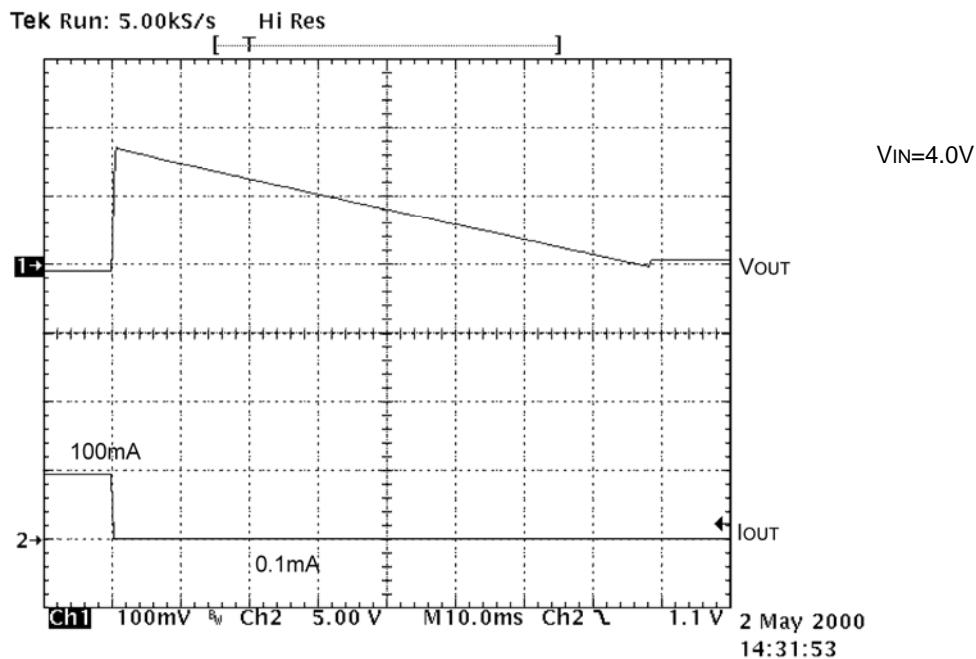
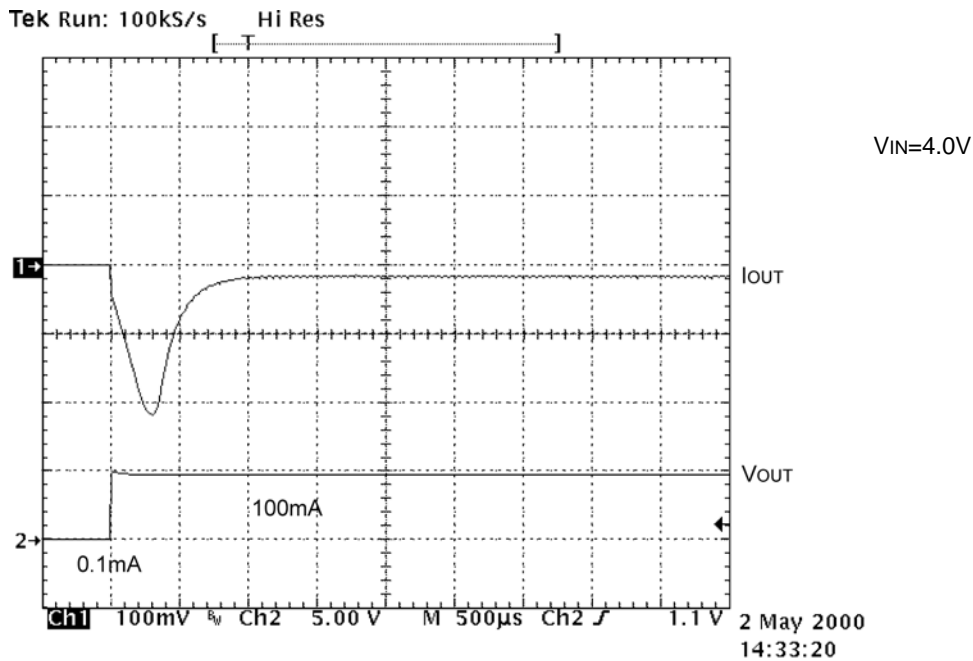

### External Components

PSW : XP162A12A6PR  
NSW : XP161A1265PR  
SD : U2FWJ44N  
L : 22  $\mu$  H (CR54)

CL : 47  $\mu$  F (MCE series Tantalum)  $\times$  2  
CIN : 220  $\mu$  F (Electrolytic, PJ type)  
RDD : 10  
CDD : 47  $\mu$  F (MCE series Tantalum)  
 $V_{CE}=V_{IN}$

## PACKAGING INFORMATION

SOT-25

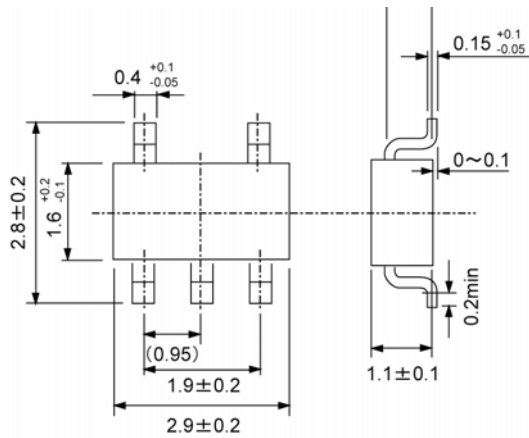

## MARKING RULE

SOT-25

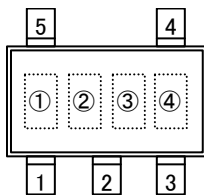

SOT-25  
(TOP VIEW)

represents the product series

MARK	PRODUCT SERIES
<u>A</u>	XC9301AxxxMx
<u>K</u>	XC9302AxxxMx

represents the integer of the output voltage and oscillation frequency

OUTPUT VOLTAGE (V)	MARK	
	FREQUENCY=180kHz (XC9301/XC9302Axx2Mx)	FREQUENCY=300kHz (XC9301/XC9302Axx3Mx)
2.x	2	2
3.x	3	3
4.x	4	4
5.x	5	5
6.x	6	6

represents decimal number of output voltage and oscillation frequency

OUTPUT VOLTAGE (V)	MARK	
	FREQUENCY=180kHz (XC9301/XC9302Axx2Mx)	FREQUENCY=300kHz (XC9301/XC9302Axx3Mx)
0.x	<u>0</u>	<u>A</u>
1.x	<u>1</u>	<u>B</u>
2.x	<u>2</u>	<u>C</u>
3.x	<u>3</u>	<u>D</u>
4.x	<u>4</u>	<u>E</u>
5.x	<u>5</u>	<u>F</u>
6.x	<u>6</u>	<u>H</u>
7.x	<u>7</u>	<u>K</u>
8.x	<u>8</u>	<u>L</u>
9.x	<u>9</u>	<u>M</u>

represents production lot number

0 to 9, A to Z reverse character 0 to 9, A to Z repeated  
(G, I, J, O, Q, W excluded)

1. The products and product specifications contained herein are subject to change without notice to improve performance characteristics. Consult us, or our representatives before use, to confirm that the information in this datasheet is up to date.
2. We assume no responsibility for any infringement of patents, patent rights, or other rights arising from the use of any information and circuitry in this datasheet.
3. Please ensure suitable shipping controls (including fail-safe designs and aging protection) are in force for equipment employing products listed in this datasheet.
4. The products in this datasheet are not developed, designed, or approved for use with such equipment whose failure or malfunction can be reasonably expected to directly endanger the life of, or cause significant injury to, the user.  
(e.g. Atomic energy; aerospace; transport; combustion and associated safety equipment thereof.)
5. Please use the products listed in this datasheet within the specified ranges.  
Should you wish to use the products under conditions exceeding the specifications, please consult us or our representatives.
6. We assume no responsibility for damage or loss due to abnormal use.
7. All rights reserved. No part of this datasheet may be copied or reproduced without the prior permission of TOREX SEMICONDUCTOR LTD.

**TOREX SEMICONDUCTOR LTD.**

Компания «Океан Электроники» предлагает заключение долгосрочных отношений при поставках импортных электронных компонентов на взаимовыгодных условиях!

Наши преимущества:

- Поставка оригинальных импортных электронных компонентов напрямую с производств Америки, Европы и Азии, а так же с крупнейших складов мира;
- Широкая линейка поставок активных и пассивных импортных электронных компонентов (более 30 млн. наименований);
- Поставка сложных, дефицитных, либо снятых с производства позиций;
- Оперативные сроки поставки под заказ (от 5 рабочих дней);
- Экспресс доставка в любую точку России;
- Помощь Конструкторского Отдела и консультации квалифицированных инженеров;
- Техническая поддержка проекта, помощь в подборе аналогов, поставка прототипов;
- Поставка электронных компонентов под контролем ВП;
- Система менеджмента качества сертифицирована по Международному стандарту ISO 9001;
- При необходимости вся продукция военного и аэрокосмического назначения проходит испытания и сертификацию в лаборатории (по согласованию с заказчиком);
- Поставка специализированных компонентов военного и аэрокосмического уровня качества (Xilinx, Altera, Analog Devices, Intersil, Interpoint, Microsemi, Actel, Aeroflex, Peregrine, VPT, Syfer, Eurofarad, Texas Instruments, MS Kennedy, Miteq, Cobham, E2V, MA-COM, Hittite, Mini-Circuits, General Dynamics и др.);

Компания «Океан Электроники» является официальным дистрибьютором и эксклюзивным представителем в России одного из крупнейших производителей разъемов военного и аэрокосмического назначения «JONHON», а так же официальным дистрибьютором и эксклюзивным представителем в России производителя высокотехнологичных и надежных решений для передачи СВЧ сигналов «FORSTAR».



## JONHON

«JONHON» (основан в 1970 г.)

Разъемы специального, военного и аэрокосмического назначения:

(Применяются в военной, авиационной, аэрокосмической, морской, железнодорожной, горно- и нефтедобывающей отраслях промышленности)

«FORSTAR» (основан в 1998 г.)

ВЧ соединители, коаксиальные кабели, кабельные сборки и микроволновые компоненты:

(Применяются в телекоммуникациях гражданского и специального назначения, в средствах связи, РЛС, а так же военной, авиационной и аэрокосмической отраслях промышленности).



Телефон: 8 (812) 309-75-97 (многоканальный)

Факс: 8 (812) 320-03-32

Электронная почта: [ocean@oceanchips.ru](mailto:ocean@oceanchips.ru)

Web: <http://oceanchips.ru/>

Адрес: 198099, г. Санкт-Петербург, ул. Калинина, д. 2, корп. 4, лит. А