

Click [here](#) for production status of specific part numbers.

MAX16141 MAX16141A

3.5V to 36V Ideal Diode Controller with Voltage and Current Circuit Breaker

General Description

The MAX16141/MAX16141A, ideal diode controllers, provide system protection against a variety of system faults, such as reverse current, reverse voltage, overcurrent, input overvoltage/undervoltage, and overtemperature conditions. The wide operating voltage range of 3.5V to 36V, combined with 5 μ A (typ) of shutdown current, make the MAX16141/MAX16141A ideal for automotive applications. An integrated charge pump drives the gate of the back-to-back external nFETs 9V above the source connection, minimizing power loss between the source and the load.

A fast-acting comparator allows the MAX16141/MAX16141A to block reverse-current flow within 1 μ s (max) of the input falling below the output voltage. An external current-sense resistor between RS and OUT provides overload monitoring capability. Two input pins, OVSET and UVSET, provide set points to protect against input overvoltage and undervoltage events using a simple resistive-divider.

During startup, the MAX16141/MAX16141A monitor the voltage drop across the external nFETs ($V_{IN} - V_{OUT}$) and the load current for overcurrent fault to ensure V_{OUT} is greater than $0.9 \times V_{IN}$. Once the startup event is complete, the MAX16141/MAX16141A are ready to protect against systems faults. During normal operation, some systems experience brownouts or short interruptions of power. To ensure smooth system recovery from these interruptions, the MAX16141/MAX16141A includes a secondary power input (V_{CC}) to keep critical circuits alive. When the main input power recovers, the MAX16141/MAX16141A enable the gate in fast mode (70 μ s, typ) to charge the output capacitor.

Both devices feature a low power mode that is enabled with a logic input. In low power mode the devices allow limited current flow from source to the load. For the MAX16141, the low power mode is enabled using an active low logic input, SLEEP. For the MAX16141A, the lower power mode is activated using an active-high logic input (SLEEP).

Additional features include an internal switch that isolates the monitoring from the UVSET and OVSET resistive network in shutdown mode to help minimize system power loss.

The MAX16141 is available in a 4mm x 4mm x 0.75mm, 16-pin TQFN package and operates over the automotive temperature range of -40°C to +125°C.

Benefits and Features

- Wide Voltage Range
 - 3.5V to 36V Operating Voltage Range
 - -36V to +60V Input Protection Voltage Range
- Eliminates Discrete Diode Power Dissipation
- Low-Power Shutdown Reduces Battery Drain
 - 5 μ A (Typ) Shutdown Current
 - Term Switch Isolates UVLO and OVLO Circuitry in Shutdown
- Isolates Failed Supply from Load
 - Bidirectional Current Blocking On Open
 - Bidirectional Voltage Blocking On Open
- Current Protection
 - Factory Adjustable Overcurrent Trip Thresholds
 - Factory Adjustable Reverse-Current Trip Thresholds
- Resistor Adjustable Overvoltage and Undervoltage Trip Thresholds
- Automotive Qualified
 - Operates Down to +3.5V, Riding Out Cold-Crank Conditions
 - -40°C to +125°C Operating Temperature Range
- N-Channel MOSFET Gate Driver of $V_{IN} + 8V$
- Fault Output
 - UVLO, OVLO, Overcurrent, Reverse-Current, and Thermal Shutdown
- AEC-Q100 Qualified MAX16141AAF/V+T

Applications

- Automotive Power Systems
- Network/Telecom Power Systems
- RAID Systems
- Servers
- PoE Systems

[Ordering Information](#) appears at end of data sheet.

Simplified Block Diagram

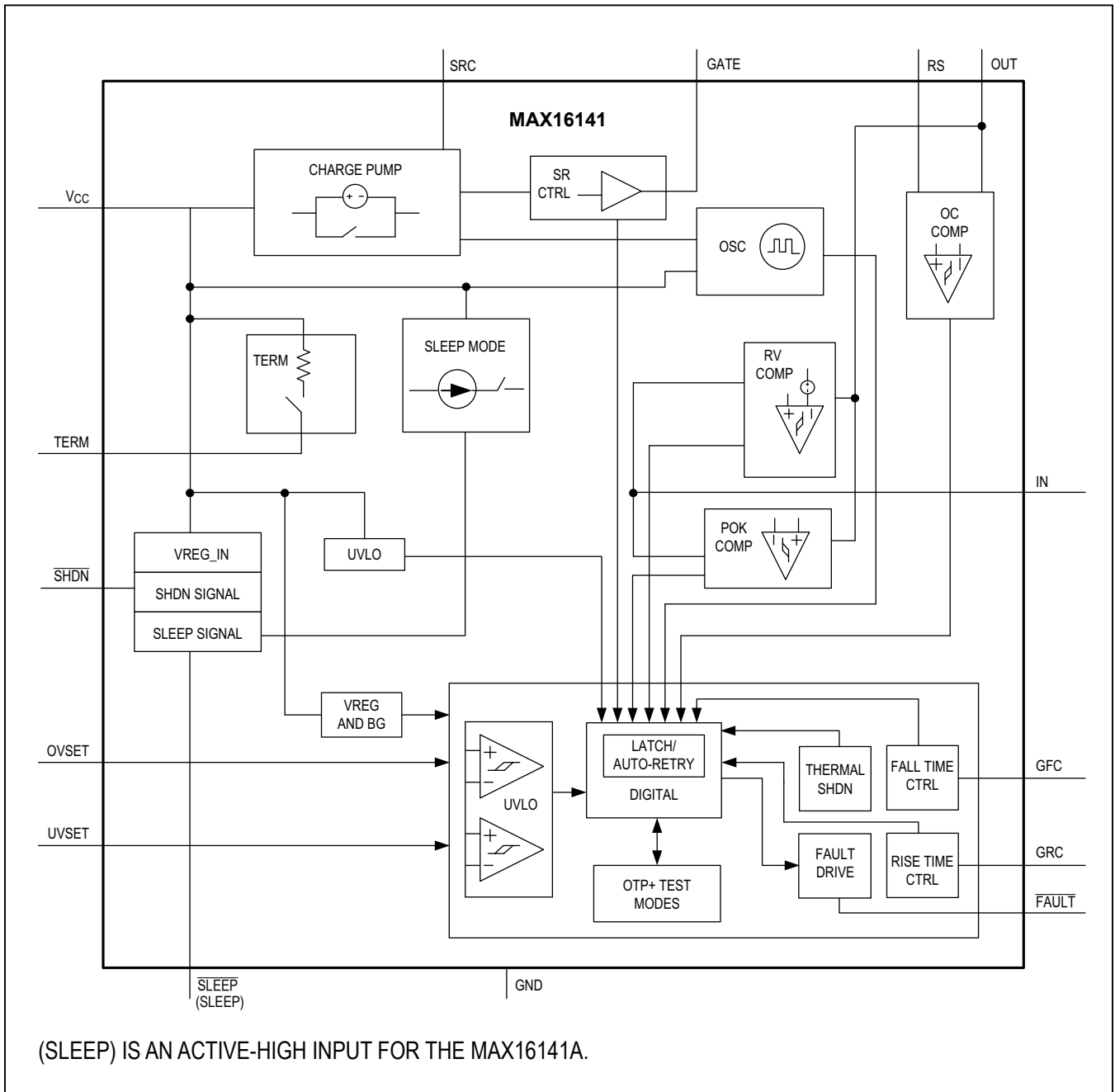

Absolute Maximum Ratings

VIN to GND	-36V to +60V
VCC, SHDN, FAULT, RS OUT to GND	-0.3V to +60V
RS, OUT to GND	-0.3V to +60V
VIN to VCC, VIN to SHDN, VIN to TERM	-45V to +60V
SRC, GATE to GND	-36V to +50V
SRC to GATE, VIN to VOUT, RS to OUT	-36V to +36V
TERM to VCC	-15V to +1V
SLEEP, SLEEP, OVSET, UVSET, GRC, GFC, to GND	-0.3V to +6V
Continuous Sink/Source Current (all pins except FAULT)	±20mA

FAULT Continuous Sink/Source Current	±5mA
Continuous Power Dissipation (TQFN 16-Pin derate 25mW/°C above +70°C.)	2000mW
Operating Temperature Range	-40°C to +125°C
Junction Temperature	+150°C
Storage Temperature Range	-60°C to +150°C
Lead Temperature (soldering 10s)	+300°C
Soldering Temperature (reflow)	+260°C

Stresses beyond those listed under "Absolute Maximum Ratings" may cause permanent damage to the device. These are stress ratings only, and functional operation of the device at these or any other conditions beyond those indicated in the operational sections of the specifications is not implied. Exposure to absolute maximum rating conditions for extended periods may affect device reliability.

Package Information

16-TQFN

Package Code	T1644+4A
Outline Number	21-0139
Land Pattern Number	90-0070
Thermal Resistance, Single-Layer Board:	
Junction to Ambient (θ_{JA})	59.30°C/W
Junction to Case (θ_{JC})	6°C/W
Thermal Resistance, Four-Layer Board:	
Junction to Ambient (θ_{JA})	40
Junction to Case (θ_{JC})	6

16-TQFN

Package Code	T1644Y+4
Outline Number	21-100267
Land Pattern Number	90-0070
Thermal Resistance, Multi-Layer Board:	
Junction to Ambient (θ_{JA})	40°C/W
Junction to Case (θ_{JC})	6°C/W

For the latest package outline information and land patterns (footprints), go to www.maximintegrated.com/packages. Note that a "+", "#", or "-" in the package code indicates RoHS status only. Package drawings may show a different suffix character, but the drawing pertains to the package regardless of RoHS status.

Package thermal resistances were obtained using the method described in JEDEC specification JESD51-7, using a four-layer board. For detailed information on package thermal considerations, refer to www.maximintegrated.com/thermal-tutorial.

MAX16141
MAX16141A

3.5V to 36V Ideal Diode Controller
with Voltage and Current Circuit Breaker

Electrical Characteristics

($V_{IN} = 12V$, $C_{GATE-SRC} = 7nF$, $C_{VCC} = 0.33\mu F$, $T_A = -40^\circ C$ to $+125^\circ C$, unless otherwise noted. Typical values are at $T_A = +25^\circ C$. All specs are subject to change.)

PARAMETER	SYMBOL	CONDITIONS	MIN	TYP	MAX	UNITS
Input Voltage Range		V_{IN} and V_{CC} Operating range	3.5		36	V
Input Protection Voltage Range	V_{IN}		-36		+60	V
INPUT SUPPLY CURRENT						
Input Supply Current	I_{IN}	$V_{SHDN} = \text{high}$, $V_{IN} = V_{SRC} = V_{OUT} = 12V$		2.0	3.8	mA
Input Supply Current	I_{IN}	$V_{SHDN} = \text{high}$, $V_{IN} = V_{SRC} = V_{OUT} = 36V$		2.1	4.0	mA
Input Supply Current	I_{IN}	$V_{SHDN} = \text{low}$, $V_{IN} = 12V$		5	10	μA
		$V_{SHDN} = \text{low}$, $V_{IN} = 36V$		6	15	
Sleep Mode Supply Current	I_{SLEEP}	Internal PFET on, charge pump off		10	15	μA
SRC Input Current	I_{SRC}	$V_{IN} = 12V$, $\overline{SHDN} = \text{high}$		1	2	mA
Undervoltage Lockout	UVLO	V_{IN} rising			3.3	V
OVSET/UVSET Input Current					100	nA
OVSET/UVSET Threshold		V_{IN} rising	0.485	0.5	0.515	V
OVSET Threshold Hysteresis	V_{OV_HYS}	OTP configuration-dependent		$0.05 \times V_{OV_TH}$		V
UVSET Threshold Hysteresis	V_{UV_HYS}	OTP configuration-dependent		$0.05 \times V_{UV_TH}$		V
TERM On-Resistance	R_{TERM}			0.7	1.3	k Ω
Startup Response Time	t_{SU}			450		μs
OVSET to GATE Prop Delay		V_{OVSET} rising from ($V_{TH_OV} - 100mV$) to ($V_{TH_OV} + 100mV$)		10		μs
UVSET to Gate Prop Delay		V_{UVSET} falling from ($V_{UV_TH} + 100mV$) to ($V_{UV_TH} - 100mV$)		20		μs
OVSET to \overline{FAULT} Prop Delay	t_{OV}	V_{OVSET} rising from ($V_{OV_TH} - 100mV$) to ($V_{OV_TH} + 100mV$)		0.3		μs
GATE OUTPUT VOLTAGE						
GATE Output Voltage High Above V_{SRC}	V_{GS}	$V_{IN} = V_{SRC} = V_{OUT} = 3.5V$, $I_{GATE} = -1\mu A$	5	6.3	8	V
		$V_{IN} = V_{SRC} = V_{OUT} = 12V$, $I_{GATE} = -1\mu A$	8	9	11	
		$V_{IN} = V_{SRC} = V_{OUT} = 24V$, $I_{GATE} = -1\mu A$	7	8.5	11	
		$V_{IN} = V_{SRC} = V_{OUT} = 36V$, $I_{GATE} = -1\mu A$	6.25	8	11	

Electrical Characteristics (continued)

($V_{IN} = 12V$, $C_{GATE-SRC} = 7nF$, $C_{VCC} = 0.33\mu F$, $T_A = -40^\circ C$ to $+125^\circ C$, unless otherwise noted. Typical values are at $T_A = +25^\circ C$. All specs are subject to change.)

PARAMETER	SYMBOL	CONDITIONS		MIN	TYP	MAX	UNITS
GATE Charge Pump Current	I_{GATE}	$V_{IN} = V_{GATE} = V_{SRC} = 12V$			1200		μA
\overline{SHDN} , \overline{SLEEP} , SLEEP Logic-High Input Voltage	V_{IH}			1.4			V
\overline{SHDN} , \overline{SLEEP} , SLEEP Logic-Low Input Voltage	V_{IL}					0.4	V
\overline{SHDN} Input Pulse Width	t_{PW_SHDN}			6			μs
\overline{SHDN} Input Pulldown Current	I_{SPD}				0.1	1.2	μA
\overline{FAULT} Output Voltage Low	V_{OL}	\overline{FAULT} sinking 1mA				0.4	V
\overline{FAULT} Leakage Current	I_{IL}	$V_{\overline{FAULT}} = 12V$				0.5	μA
OUT Input Resistance	R_{OUT}				4		$M\Omega$
REVERSE CURRENT THRESHOLD							
Reverse-Current Threshold	$V_{(OUT-IN)}$			7	10	14	mV
Reverse Current-Blocking Response Time	t_{REV}	Overdrive Threshold Voltage = 40mV			0.3	1	μs
Fast Reverse Recovery Turn-On Time (Note 2)	t_{REV_FAST}	Gate rise from GND to $V_{SRC} + 3.5V$, $C_{GS} = 7nF$. (Note 1)	100 Ω from GATE to gate of the MOSFETs			70	μs
OVERCURRENT THRESHOLDS							
Overcurrent Threshold (Note 2)	$V_{(RS-OUT)}$			22.5	25	27.5	mV
Overcurrent Response Time		Comparator overdrive = 40mV, Response time is measured from overcurrent event to \overline{FAULT} pulling low				0.5	μs
Thermal Shutdown	T_{HSHDN}				+145		$^\circ C$
Thermal Shutdown Hysteresis	T_{HSHDN_HYS}				15		$^\circ C$
Power OK Threshold		V_{OUT} rising			$0.9V \times V_{IN}$		V
Power OK Threshold		V_{OUT} falling			$0.87 \times V_{IN}$		V

Electrical Characteristics (continued)

($V_{IN} = 12V$, $C_{GATE-SRC} = 7nF$, $C_{VCC} = 0.33\mu F$, $T_A = -40^{\circ}C$ to $+125^{\circ}C$, unless otherwise noted. Typical values are at $T_A = +25^{\circ}C$. All specs are subject to change.)

PARAMETER	SYMBOL	CONDITIONS	MIN	TYP	MAX	UNITS
GATE RAMP RATE CONTROL CURRENT						
Gate Rise Time		$R_{GRC} = 10k\Omega$, gate rising from ground to $V_{SRC} + 3.5V$		10		ms
		$R_{GRC} = 20k\Omega$, gate rising from ground to $V_{SRC} + 3.5V$		20		
		$R_{GRC} = 40k\Omega$, gate rising from ground to $V_{SRC} + 3.5V$		40		
GATE RAMP DOWN						
Gate Fall Time		$R_{GFC} = 20k\Omega$, GATE is falling from $(V_{SRC} + 8V)$ to V_{SRC}	200			μs
		$R_{GFC} = 10k\Omega$, Gate falling from $(V_{SRC} + 8V)$ to V_{SRC}	100			
GATE Pulldown Current		Active during reverse bias detection to achieve $1\mu s$ (max) response time		0.280		A

Note 1: Tested with MOSFETs, NVD6824NL.

Note 2: Guaranteed by design and bench characterization.

Note 3: Specifications with minimum and maximum limits are 100% production tested at $T_A = +25^{\circ}C$ and are guaranteed over the operating temperature range by design and characterization. Actual typical values may vary and are not guaranteed.

Typical Operating Characteristics

$V_{IN} = V_{CC} = 12V$, $C_{VCC} = 0.33\mu F$, $T_A = -40^{\circ}C$ to $+125^{\circ}C$, unless otherwise noted.

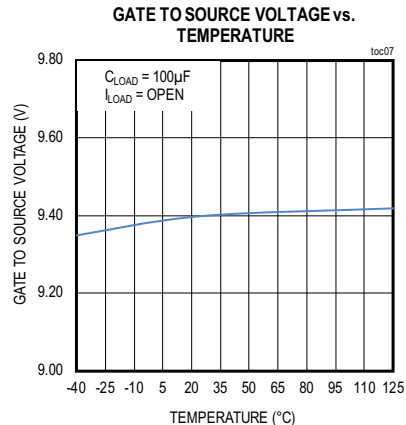
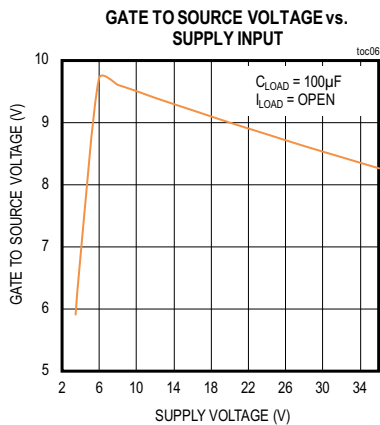
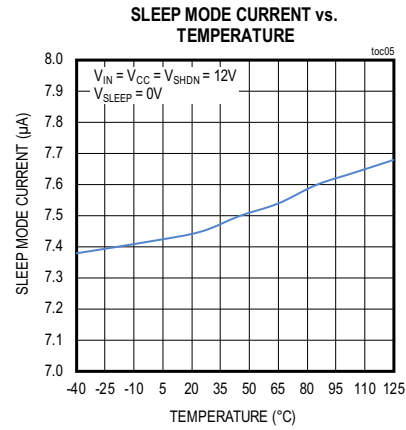
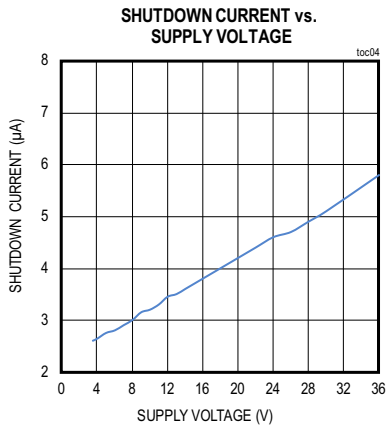
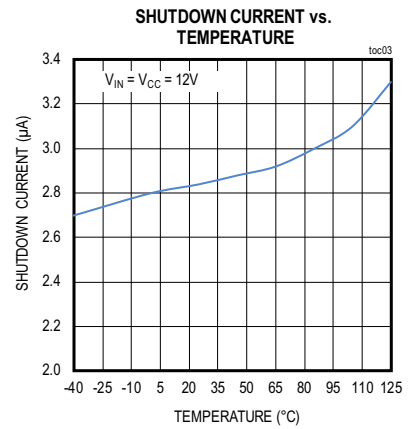
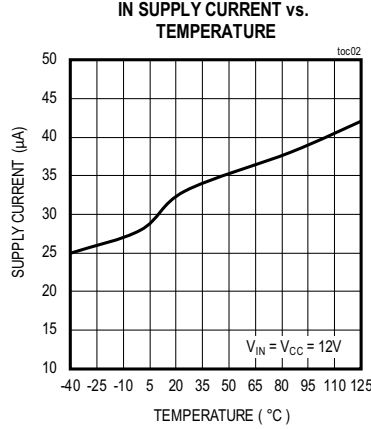
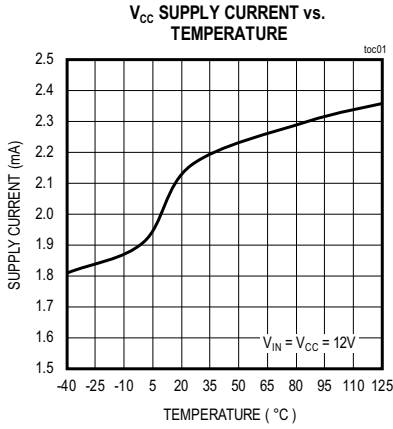

Typical Operating Characteristics (continued)

$V_{IN} = V_{CC} = 12V$, $C_{VCC} = 0.33\mu F$, $T_A = -40^\circ C$ to $+125^\circ C$, unless otherwise noted.

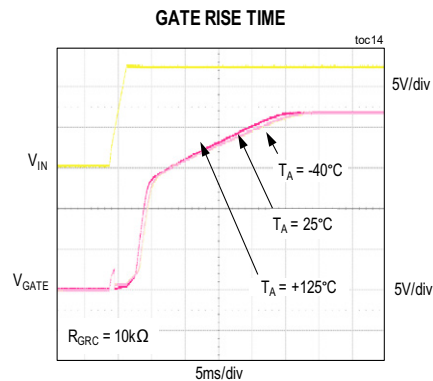
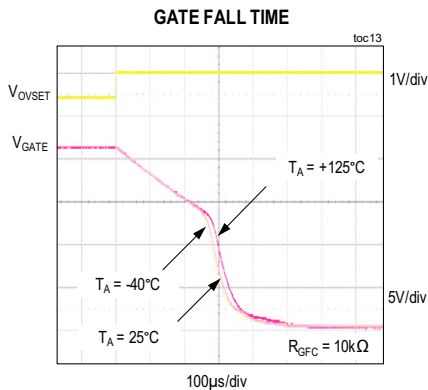
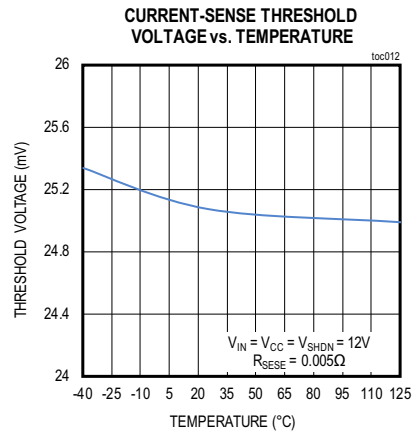
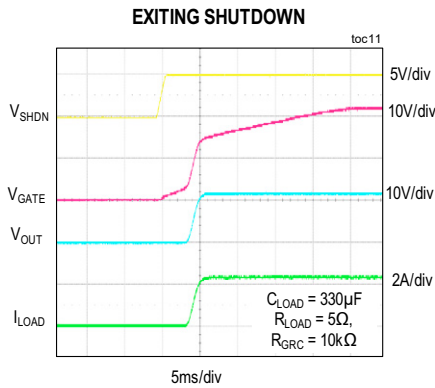
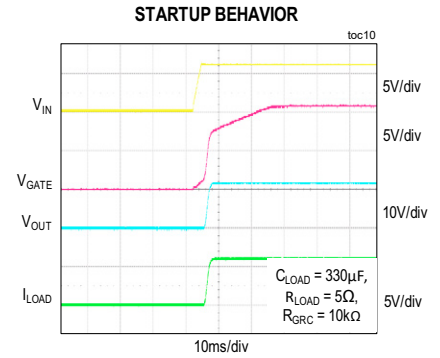
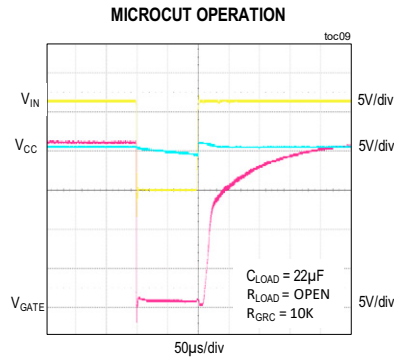
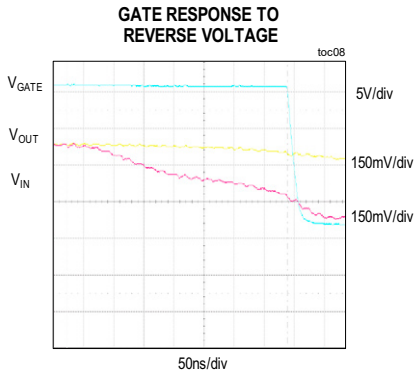

Pin Configuration

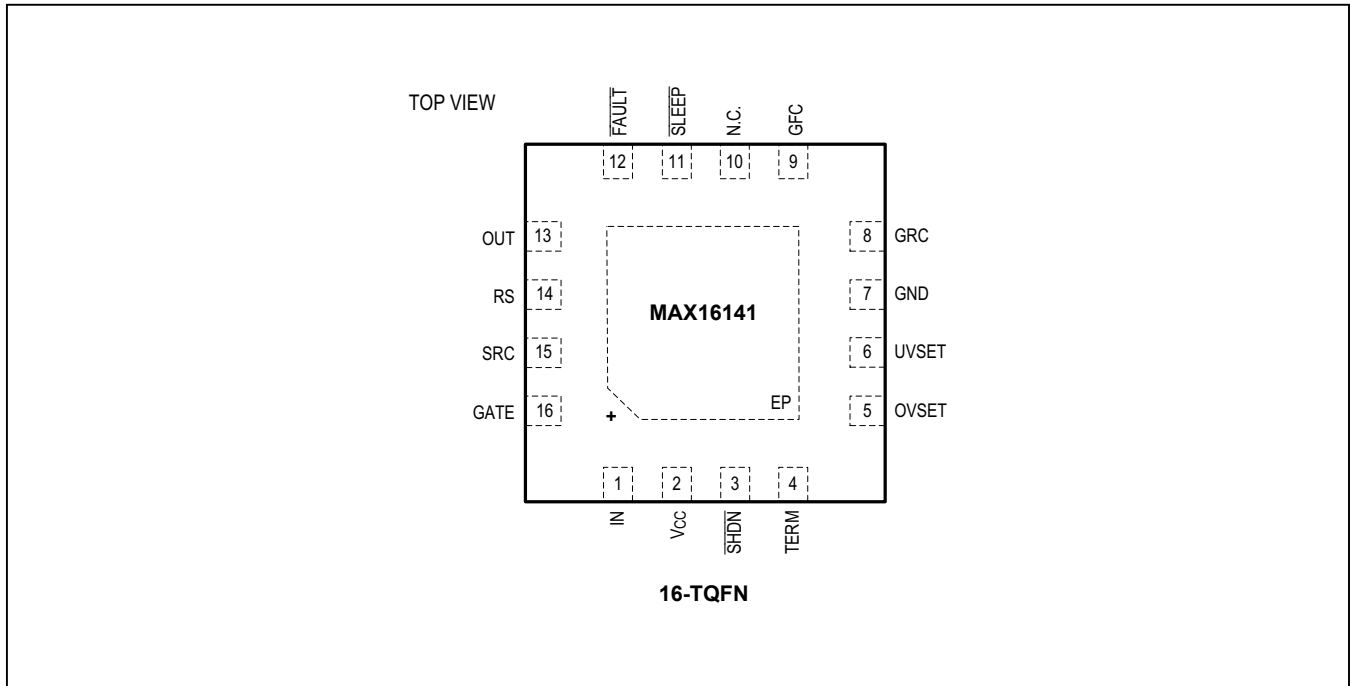

Pin Description

PIN	NAME	FUNCTION
1	IN	Sense Input. Bypass IN with a 0.1µF ceramic capacitor to GND.
2	V _{CC}	Auxiliary Power Input. V _{CC} provides power to the MAX16141/MAX16141A during short interruption of power at IN. Connect V _{CC} to IN through a diode. Bypass V _{CC} to ground with a 0.1µF capacitor.
3	$\overline{\text{SHDN}}$	Active-Low Shutdown Input. Drive $\overline{\text{SHDN}}$ low to drive GATE low and TERM to high-impedance state. Drive $\overline{\text{SHDN}}$ high for normal operation.
4	TERM	UVSET/OVSET Voltage-Divider Termination Output. TERM is internally connected to V _{CC} through a switch. Connect TERM to the high-side of the UVSET/OVSET resistive-divider network for undervoltage and overvoltage settings.
5	OVSET	Overvoltage Threshold Adjustment Input. Connect a resistive-divider from TERM to OVSET and GND to set the overvoltage threshold.
6	UVSET	Undervoltage Threshold Adjustment Input. Connect a resistive-divider from TERM to UVSET and GND to set the undervoltage threshold.
7	GND	Ground
8	GRC	Gate Rise Control Input. Connect a resistor from GRC to ground to set the gate rise time. See Electrical Characteristics for appropriate resistor values.
9	GFC	Gate Fall Control Input. A resistor from GFC to ground allows the MAX16141/MAX16141A to disable the gate slower in the event of an overvoltage fault. See Electrical Characteristics for appropriate resistor values.
10	N.C.	No Connect. Connect to ground.

Pin Description (continued)

PIN	NAME	FUNCTION
11	$\overline{\text{SLEEP}}$ / SLEEP	Sleep Mode input. In Sleep mode, the gate drive is disabled and power to the load flows through an internal low-power switch and the body diode of the ORing FET.
12	$\overline{\text{FAULT}}$	Active-Low, Open-Drain Fault Output. $\overline{\text{FAULT}}$ requires a pullup resistor.
13	OUT	Load Current/Output Voltage Sense Input. OUT is internally connected to a current-sense comparator input and a voltage comparator. During normal operation, the MAX16141/MAX16141A monitor the overcurrent conditions using a sense resistor between RS and OUT. During the reverse-voltage condition, the MAX16141/MAX16141A enter a fault mode when the voltage between OUT and IN exceeds the set threshold.
14	RS	Current Sense Positive Input. RS is internally connected to the positive input of a current-sense resistor. Connect a sense resistor between RS and OUT to set the overload threshold.
15	SRC	Source Input. Connect SRC to the common source connection of the external n-channel MOSFETs. An external zener diode between SRC and GATE protects the gates of the external MOSFETs.
16	GATE	Gate-Driver Output. Connect GATE to the gates of the external n-channel MOSFETs. GATE is the charge-pump output during normal operation. GATE is quickly pulled low during a fault condition or when $\overline{\text{SHDN}}$ is pulled low.

Functional Diagram

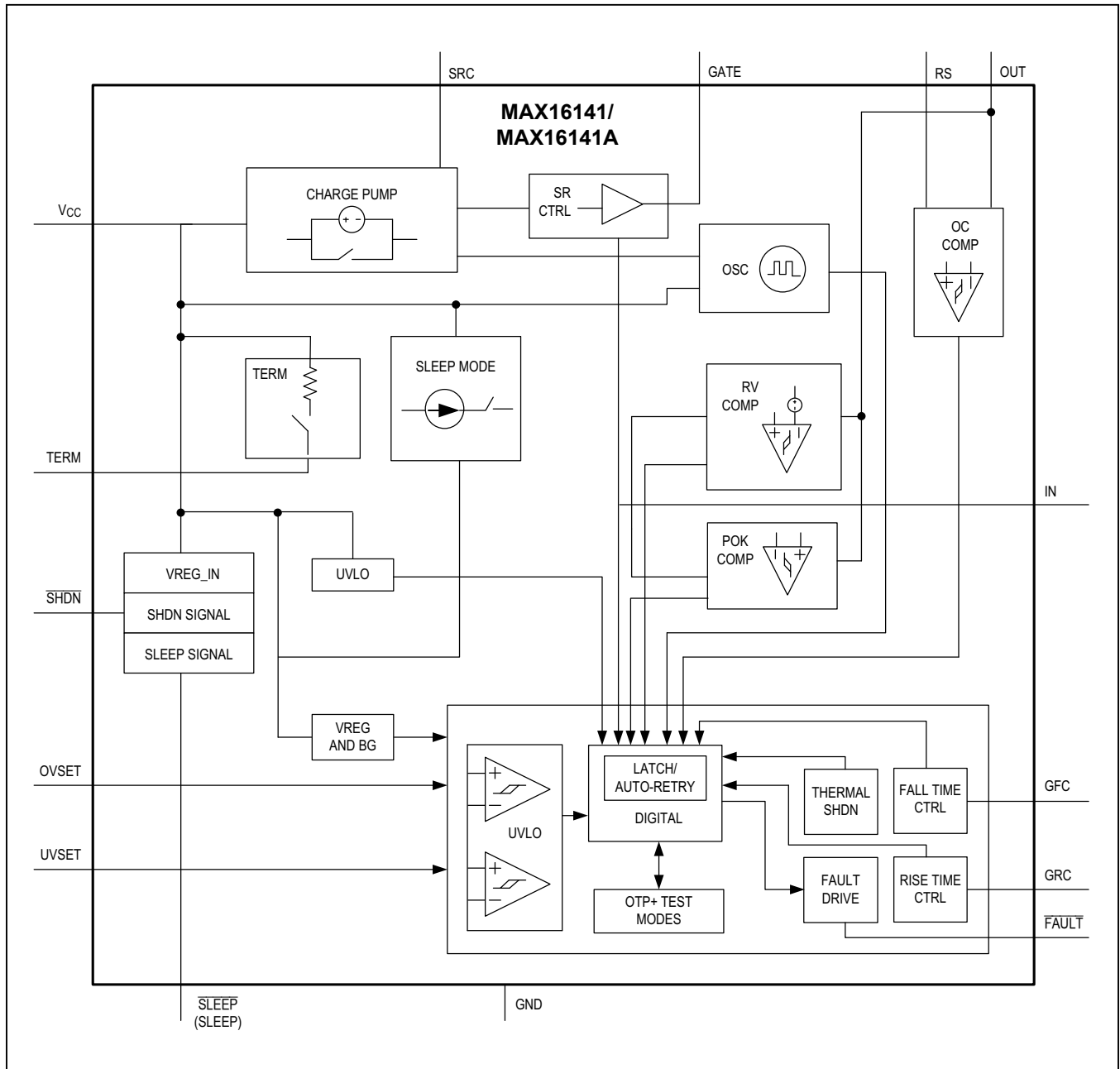

Detailed Description

Device Operation

The MAX16141/MAX16141A is an ideal diode controller featuring several system-level protections, such as reverse-current, overcurrent, overvoltage, undervoltage, and overtemperature faults. The MAX16141/MAX16141A consume only 5 μ A (typ) in shutdown mode. During a reverse condition, $V_{OUT} > V_{IN}$, the MAX16141/MAX16141A disables the gate within 1 μ s (max) of V_{IN} falling below V_{OUT} by the factory-set threshold.

An internal charge pump drives the gate above the source voltage to fully turn on two external back-to-back N-channel FETs, minimizing power dissipation and voltage drop across the FETs. The MAX16141/MAX16141A monitor the load current using a sense resistor between RS and OUT and protects against reverse current flow when V_{IN} fall below V_{OUT} . This device features gate ramp rate control to provide correct operation in a variety of situations. For example, the ramp-up during power-up can be adjusted to avoid excessive inrush current. In the case of an overvoltage fault, the ramp down rate is slow enough to avoid large inductive transients when interrupting high fault currents. On the other hand, the gate drive responds quickly to transient shorts of the input to ground, thereby preventing discharge of the load-side capacitance. When the input recovers, the gate drive ramps up quickly enough to provide power to the load before the load voltage can drop excessively.

Power-Up

At power-up, the MAX16141/MAX16141A monitors the output and releases the gate after 450 μ s of startup delay (t_{SU}). During power-up, the gate's rise time is determined by value of resistor connected between GRC and GND, while \overline{FAULT} remains low and goes high-impedance when the output voltage is greater than 90% of V_{IN} if no fault condition is present.

Undervoltage Protection

The MAX16141/MAX16141A monitor the input voltage for undervoltage fault. An external resistive divider connected between TERM, UVSET, and GND sets the undervoltage threshold (TERM is connected to V_{CC} through a switch when \overline{SHDN} is high). When the input voltage falls below the undervoltage threshold ($V_{CC} = V_{IN} < V_{UVTH} - V_{HYS}$), the MAX16141/MAX16141A pull the gate voltage low, turning off the external MOSFETs, and FAULT asserts. When the input voltage rises above the undervoltage threshold ($V_{CC} = V_{IN} > V_{UVTH}$), GATE goes high after a 450 μ s startup delay (typ).

Overvoltage Protection

The MAX16141/MAX16141A detect an overvoltage conditions using an external resistive divider connected between TERM, OVSET, and GND (TERM is connected to V_{CC} through a switch when \overline{SHDN} is high). When the input voltage exceeds the programmed overvoltage threshold, the MAX16141/MAX16141A isolate the load from the input and disables GATE low with a slow falling ramp rate, as selected by the resistor value between GFC and ground. See [Electrical Characteristics](#) for GATE's fall times versus resistor values. During the overvoltage fault condition, GATE latches low and FAULT stays asserted.

Overvoltage/Undervoltage Threshold Hysteresis

The MAX16141/MAX16141A offer 6 factory-set overvoltage/undervoltage threshold hysteresis options. See [Figure 5](#) for available options.

Overcurrent Protection

The MAX16141/MAX16141A detect an overcurrent fault condition using a sense resistor between RS and OUT. When the load current exceeds the factory-set threshold, the MAX16141/MAX16141A isolate the load from the input and disables GATE low with a slow falling ramp rate, as selected by the resistor value between GFC and ground. See [Electrical Characteristics](#) table for GATE's fall times versus resistor values. During the overcurrent fault condition, GATE enters the 300ms auto-retry mode while FAULT stays asserted. Upon termination of an overcurrent fault condition, the MAX16141/MAX16141A pull the gate voltage high and allow the fault to deassert.

The MAX16141/MAX16141A offer 4 factory-set overcurrent threshold options. See [Figure 5](#) for available options.

Ideal Diode Reverse-Current Protection

The MAX16141/MAX16141A detect a reverse-current condition using a comparator that monitors the differential voltage between IN and OUT. When V_{IN} falls below V_{OUT} by the factory-set thresholds, the MAX16141/MAX16141A disable the gate drive within 1 μ s (max) to minimize load discharge into the source. The gate drive is enabled once the input rises above the output voltage by 50mV. The MAX16141/MAX16141A offer 4 factory-set reverse-current thresholds. See [Figure 5](#) for available options.

Reverse-Voltage Protection

The MAX16141/MAX16141A integrate reverse-voltage protection, preventing damage to the downstream circuitry caused by battery reversal or negative transients. The devices can withstand reverse voltage to -36V. When IN is forced below ground, an internal circuitry blocks current flow from

MAX16141 MAX16141A

3.5V to 36V Ideal Diode Controller with Voltage and Current Circuit Breaker

GND to IN to protect the MAX16141/MAX16141A during negative transients events. During a reverse-voltage condition, the two external n-channel MOSFETs are turned off, protecting the load. Connect a 0.1µF ceramic capacitor from IN to GND. During normal operation, both MOSFETs are turned on and have a minimal forward voltage drop, providing lower power dissipation and a much lower voltage drop than a reverse-battery protection diode.

Thermal Shutdown Protection

The MAX16141/MAX16141A include thermal shutdown protection that turns off the external MOSFETs if the internal die temperature exceeds +145°C (T_J). By ensuring good thermal coupling between the MOSFETs and the MAX16141/MAX16141A, the thermal shutdown can turn off the MOSFETs if they overheat. When the junction temperature exceeds $T_J = +145^\circ\text{C}$ (typ), the internal thermal sensor signals the shutdown logic, pulling the GATE voltage low and allowing the device to cool. The MAX16141/MAX16141A isolate the load from the input by pulling the gate to ground with a slow falling ramp rate to prevent transient overshoots beyond the input protection voltage and asserts FAULT. When T_J drops by 15°C (typ), GATE goes high with a slow rising ramp rate and the MOSFETs turn back on. Do not exceed the absolute maximum junction-temperature rating of $T_J = +150^\circ\text{C}$.

GATE Ramp-Up Control

To ensure proper power-up, the MAX16141/MAX16141A offers 3 different gate rise-times set with a resistor connected from GRC to GND. See [Electrical Characteristics](#) for more detail. The gate's controlled rise-time ensures soft-start with limited inrush current and is active during power-up,

when exiting shutdown, recovering from undervoltage, overvoltage, and thermal faults.

Note: The values in the electrical characteristics table are determined based on a 7nF gate-to-source capacitance. Depending on the gate-to-source capacitance, the rise time of the gate will be different.

GATE Ramp-Down Control

The MAX16141/MAX16141A control the gate fall time using a resistor from GFC to ground. The gate's fall-time control remains active during overvoltage, undervoltage, overcurrent and thermal fault is detected. The gate's fall-time-control is not active when the MAX16141/MAX16141A enter shutdown mode or detects reverse current fault condition. See [Electrical Characteristics](#) for more detail.

Sleep Mode

The MAX16141/MAX16141A feature a low power mode that is enabled with a logic level input. In low power mode the devices allow limited current flow from source to the load. For the MAX16141, the low power mode is enabled using an active-low logic input, SLEEP. For the MAX16141A, the lower power mode is activated using an active-high logic input, SLEEP. In sleep mode, the MAX16141/MAX16141A consume about 10µA (typ) of current while sources up to 400µA (typ) to the load. During sleep mode, the gate drive remains disabled and the MAX16141/MAX16141A provides power to the load through the body diode of the MOSFET that is connected to SRC and an internal switch. See [Figure 1](#) for more detail.

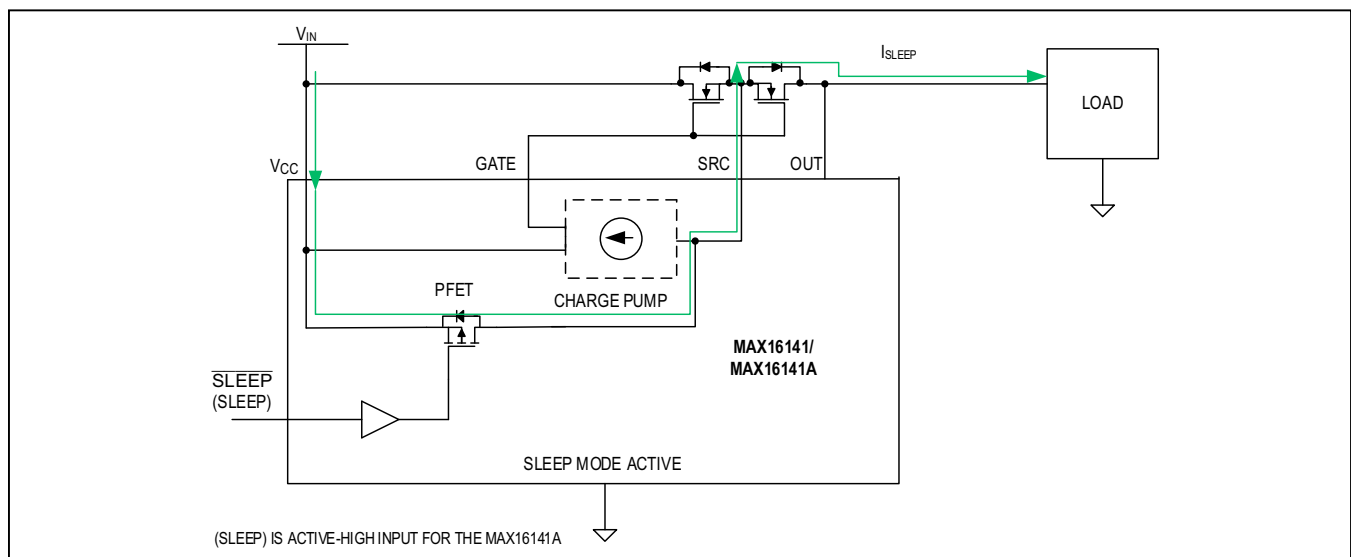

Figure 1. Sleep Mode Operation

Gate Charge Pump

An internal charge pump generates the GATE-to-SRC voltage to enhance the external MOSFETs. After the input voltage exceeds the input undervoltage threshold, the charge pump turns on after a 450µs startup (t_{SU}) delay. During a fault condition, GATE is disabled with a 280mA (typ) pulldown current.

TERM Connection

The TERM connection has an internal switch to V_{CC} . In shutdown ($\overline{SHDN} = \text{low}$), this switch is open. By connecting the voltage threshold resistive divider to TERM instead of directly to V_{CC} , power dissipation in the resistive divider can be eliminated and the supply current in shutdown mode reduced.

During shutdown mode, the $(V_{CC} - V_{TERM})$ can be as high 60V but $(V_{TERM} - V_{CC})$ must be limited to < 1V due to parasitic diode.

\overline{FAULT} Output

\overline{FAULT} is an open-drain output that indicates fault conditions. During startup, \overline{FAULT} is initially low and goes high-impedance when V_{OUT} is greater than 90% of V_{IN} if no fault conditions are present. \overline{FAULT} asserts low during shutdown mode, reverse-current, overcurrent, overvoltage, thermal shutdown, or undervoltage faults, or when V_{OUT} falls below 90% of V_{IN} .

Auto-Retry

The MAX16141/MAX16141A enter auto-retry mode of 300ms during overcurrent, output short-circuit and thermal shutdown faults only. In auto-retry mode, the gate drive is enabled every 300ms (typ) to check if the fault condition is removed or not. If the fault is active, the gate will be pulled low after a short duration of 20ms(typ). If the fault condition is removed, the gate will stay on and the MAX16141/MAX16141A resume normal operation. During these fault conditions, \overline{FAULT} asserts low and deasserts once the fault conditions are removed.

Applications Information

Setting Overvoltage/Undervoltage Threshold

The MAX16141/MAX16141A features window-detection threshold comparators. The noninverting input of the undervoltage comparator shares the same reference voltage connected to the inverting input of the overvoltage comparator. This configuration allows using three-resistor network to set both undervoltage and overvoltage thresholds.

The top of the resistive divider network connects to TERM. See Figure 2. When the input voltage falls outside the set window-threshold, the gate voltage is disabled and the n-channel MOSFETs are turned off. Use the equations below to set the thresholds:

$$V_{UVTH} = (V_{TH} - V_{TH_HYS}) \left[\frac{R_{TOTAL}}{R_2 + R_3} \right],$$

$$V_{OVTH} = (V_{TH}) \left[\frac{R_{TOTAL}}{R_3} \right],$$

Where V_{UVTH} and V_{OVTH} are the undervoltage and overvoltage thresholds respectively, $R_{TOTAL} = R_1 + R_2 + R_3$, V_{TH} is the 0.5V for OVSET and UVSET threshold, and the V_{TH_HYS} is the hysteresis.

Use the steps below to determine values for R1, R2, and R3.

- 1) Choose a value for R_{TOTAL} , the sum of R1, R2, and R3.
- 2) Calculate R3 based on R_{TOTAL} and the desired overvoltage threshold point, V_{OVTH} :

$$R_3 = \left(\frac{V_{TH} \times R_{TOTAL}}{V_{OVTH}} \right)$$

- 3) Calculate R2 based on R_{TOTAL} , R3 and the desired undervoltage threshold point, V_{UVTH} :

$$R_2 = \left(\frac{(V_{TH} - V_{TH_HYS}) \times R_{TOTAL}}{V_{UVTH}} \right) - R_3$$

- 4) Calculate R1 based on R_{TOTAL} , R2 and R3:

$$R_1 = R_{TOTAL} - R_2 - R_3$$

MAX16141
MAX16141A

3.5V to 36V Ideal Diode Controller
with Voltage and Current Circuit Breaker

The MAX16141 offers factory threshold hysteresis for undervoltage and overvoltage threshold settings.

Reverse-Voltage Protection

Traditionally, discrete diodes have been used to block reverse current flow and prevent output capacitor discharge. However, for high-current applications, ideal diode controllers (FET-based solutions) are more appealing

due to their low power dissipation. But, unlike a discrete diode that blocks reverse current instantaneously, a typical ideal diode controller reacts much more slowly. To prevent heavy discharge of the load-side capacitor in the case of a fault that shorts the input to ground, the MAX16141/MAX16141A disable the gate drive within 1µs (max) of detection of the reverse-voltage condition. See [Figure 3](#).

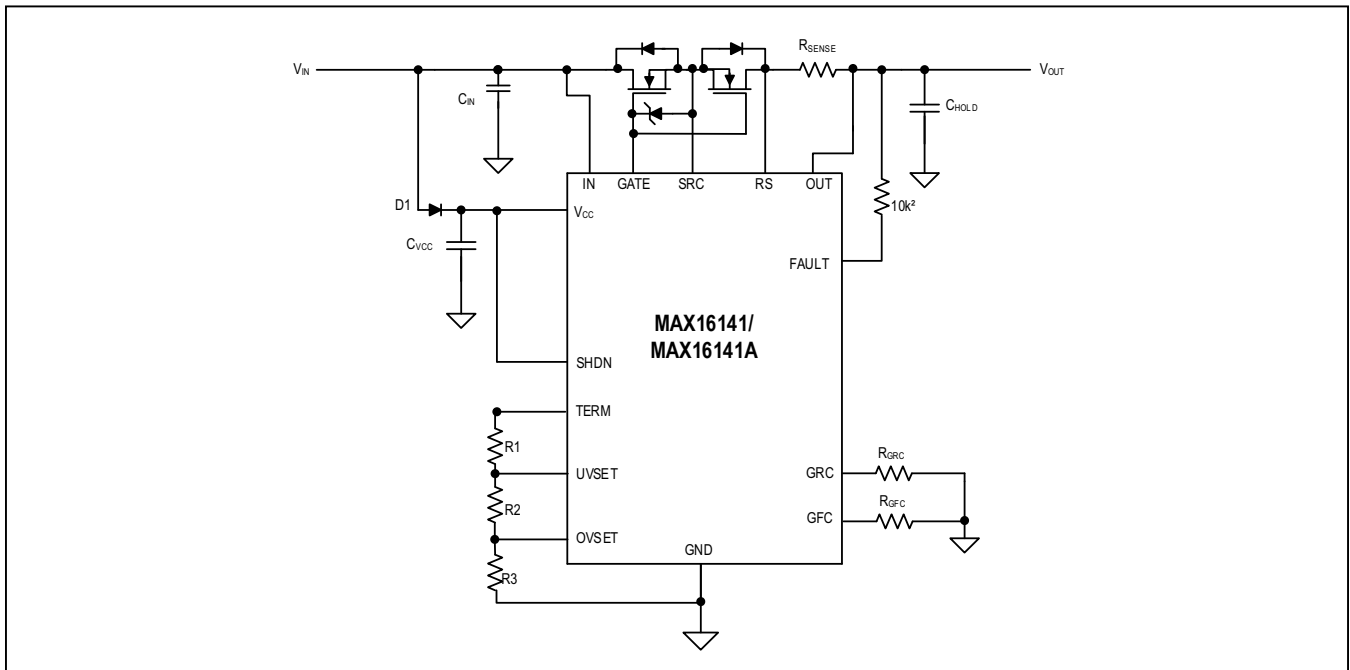

Figure 2. UVSET and OVSET Thresholds Setting

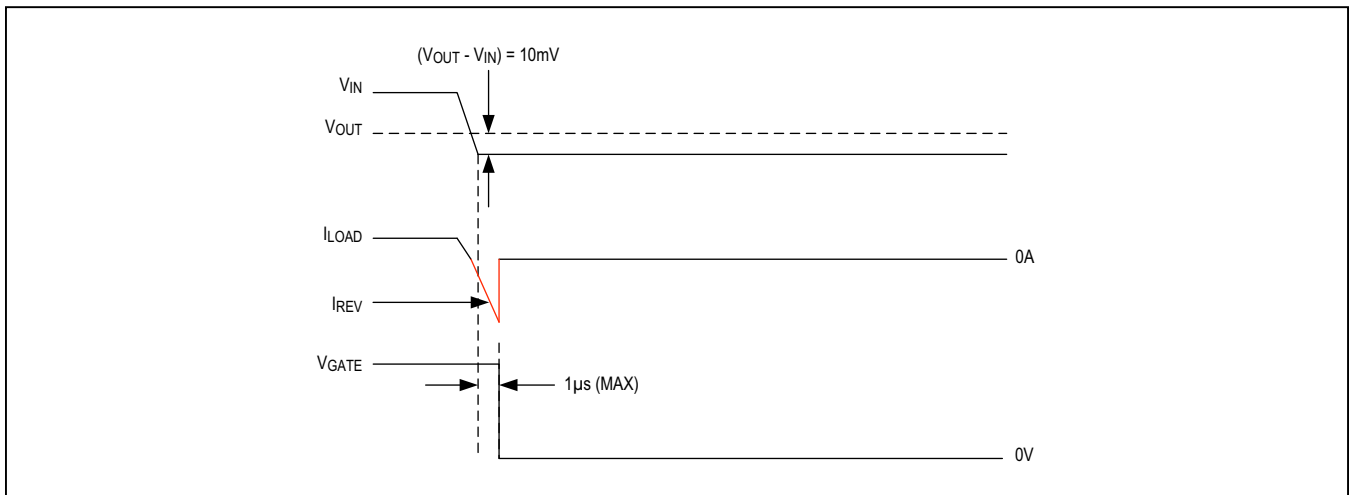

Figure 3. Reverse-Voltage Fault

MAX16141 MAX16141A

3.5V to 36V Ideal Diode Controller with Voltage and Current Circuit Breaker

The MAX16141/MAX16141A protect against negative input voltage down to -36V. High leakage current of the back-to-back MOSFETs and diode(D1) between IN and V_{CC} can cause OUT and V_{CC} pins to drop below their minimum ABS max ratings. For proper protection against negative input voltage, low leakage MOSFETs and diode is recommended.

Overcurrent Threshold Setting

Use the formula below to set the overcurrent threshold:

$$I_{OC} = V_{(RS-OUT)}/R_{SENSE}$$

where,

V_(RS-OUT) is the overcurrent threshold voltage in Volts

R_{SENSE} is the resistor in Ohms connected between RS and OUT.

Short Power Interruptions

In an automotive environment, systems usually experience brief power interruptions where the main supply is shorted to ground. The power interruption may last for several seconds; and the only source of power to system load is the output capacitance. To ensure fast recovery, an auxiliary input (V_{CC}) helps keep the MAX16141/MAX16141A standby mode for 100µs (typ). When the main supply input (IN) recovers, the MAX16141/MAX16141A initiate a fast recovery mode that allows the gate to reach its peak voltage within 70µs (typ). See [Figure 4](#) for more detail. Therefore, brief power supply interruptions will not affect operation of the load, as long as the load-side

capacitance is sufficiently large to power the load during the interruption.

Since V_{CC} provides power to the MAX16141 when the main supply is shorted to ground, a low-leakage diode such as CMPD4150 from V_{IN} to V_{CC} and a bulk capacitance is required to keep the MAX16141/MAX16141A in standby mode. See [Typical Application Circuit](#) for proper connection. The size of the bulk capacitance is dictated by the expected duration of the power interruption and supply current of the MAX16141/MAX16141A. Below is a simple bulk capacitance calculation for 100µs power interruption and 1V drop in V_{CC} voltage.

$$C_{VCC} = \frac{(I_{CC} \times 100 \times 10^{-6})}{\Delta V_{CC}}$$

Where C_{VCC} is the bulk capacitance at V_{CC}, I_{CC} is the supply current in amper, and ΔV_{CC} is the desired droop in V_{CC} in volts.

$$\frac{(3 \times 10^{-3} \text{ (A)} \times 100 \times 10^{-6} \text{ (s)})}{1\text{V}} \approx 0.33\mu\text{F}$$

Note: If the input voltage sags slowly and the output follows, the differential voltage between the input and output may always be less than factory-set threshold. In this case, the reverse-current fault may not occur. Instead, an undervoltage fault may eventually be detected; causing the gate drive to be disabled.

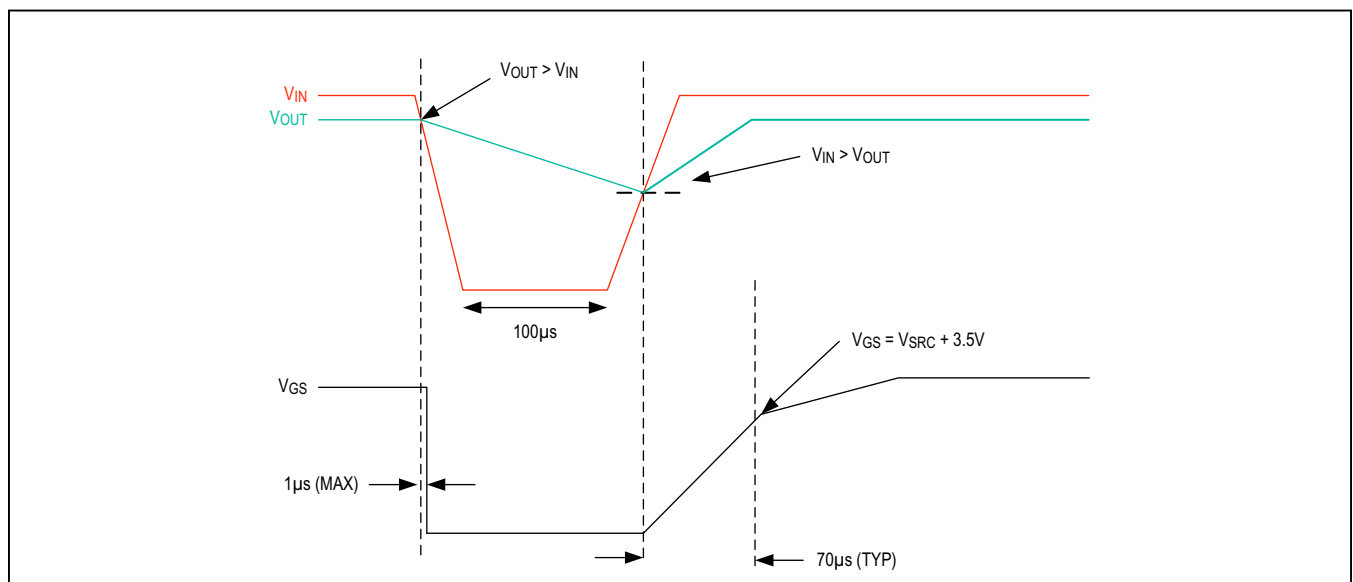

Figure 4. Short Power Interruption and Recover

MOSFET Selection

MOSFET selection is critical to design a proper protection circuit. Several factors must be considered: the gate capacitance, the drain-to-source voltage rating, the on-resistance ($R_{DS(ON)}$), the peak power dissipation capability, and the average power dissipation limit. In general, both MOSFETs should have the same part number. For size-constrained applications, a dual MOSFET can conserve board area. Select the drain-to-source voltage so that the MOSFETs can handle the highest voltage that might be applied to the circuit. Gate capacitance is not as critical, but it does determine the maximum turn-on and turn-off time. MOSFETs with more gate capacitance tend to respond more slowly.

MOSFET Power Dissipation

The $R_{DS(ON)}$ must be low enough to limit the MOSFET power dissipation during normal operation. Power dissipation (per MOSFET) during normal operation can be calculated using this formula:

$$P = I_{LOAD}^2 \times R_{DS(ON)}$$

where P is the power dissipated in each MOSFET and I_{LOAD} is the average load current.

During a fault condition in switch mode, the MOSFETs turn off and do not dissipate power.

Since limiter mode can involve high switching currents when the GATE is turning on at the start of a limiting cycle (especially when the output capacitance is high), it is important to ensure the circuit does not violate the peak power rating of the MOSFETs. Check the pulse power ratings in the MOSFET data sheet.

MOSFET Gate Protection

To protect the gate of the MOSFETs, connect a Zener clamp diode from the gate to the source. The cathode connects to the gate, and the anode connects to the source. Choose the Zener clamp voltage to be above 10V and below the MOSFET V_{GS} maximum rating.

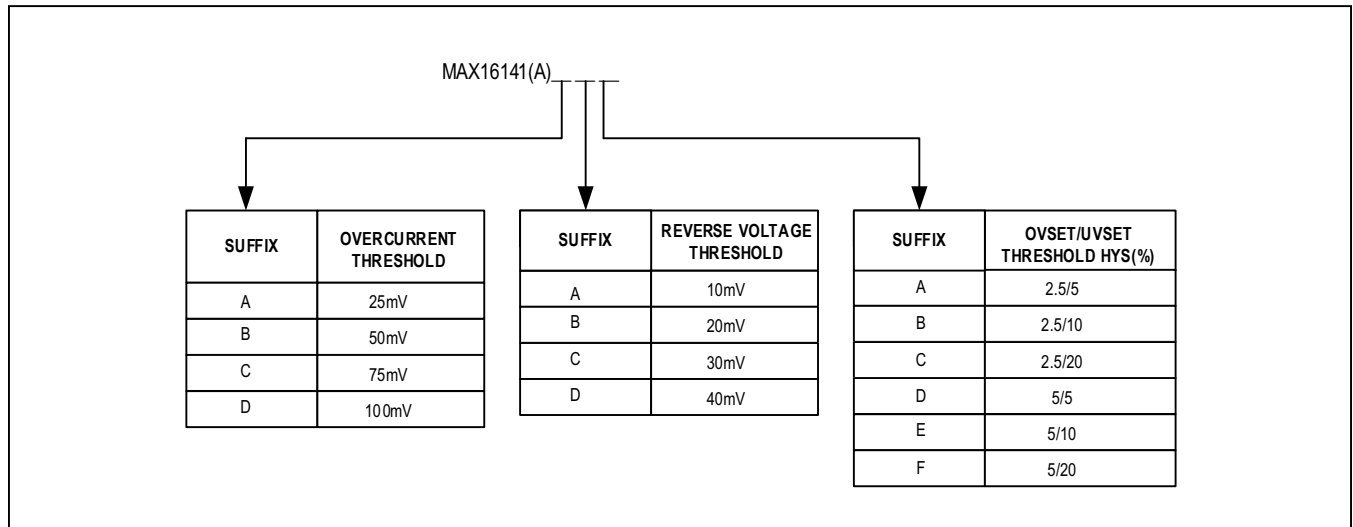
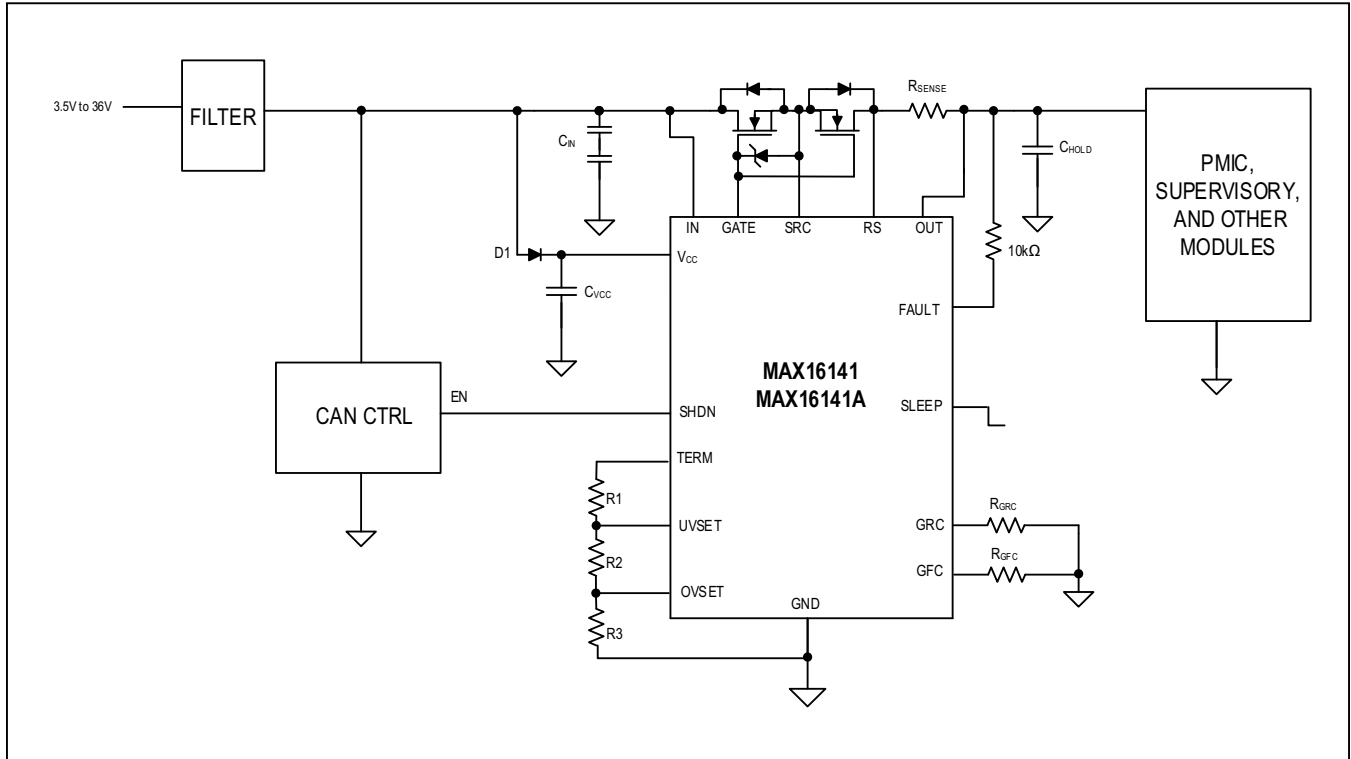

Figure 5. Selector Guide

MAX16141
MAX16141A

3.5V to 36V Ideal Diode Controller with Voltage and Current Circuit Breaker

Typical Application Circuit



MAX16141
MAX16141A

3.5V to 36V Ideal Diode Controller
with Voltage and Current Circuit Breaker

Ordering Information

PART NUMBER	TEMP RANGE	PIN-PACKAGE
MAX16141AAF+T	-40°C to +125°C	16-TQFN
MAX16141AAF/V+T	-40°C to +125°C	16-TQFN
MAX16141AAAF/VY+T*	-40°C to +125°C	16-TQFN

+ Denotes a lead(Pb)-free/RoHS-compliant package.

T Denotes tape-and-reel.

/V denotes automotive qualified parts.

*Future product—contact factory for availability.

Note: See the [Figure 5](#) for overcurrent, reverse-current, overvoltage, and undervoltage hysteresis options. Contact factory for availability of variants not listed in the [Ordering Information](#) table (10k units minimum order quantity).

MAX16141
MAX16141A

3.5V to 36V Ideal Diode Controller with Voltage and Current Circuit Breaker

Revision History

REVISION NUMBER	REVISION DATE	DESCRIPTION	PAGES CHANGED
0	6/18	Initial release	—
1	7/18	Updated <i>Electrical Characteristics</i> table, <i>Detailed Description</i> section, <i>Ordering Information</i> table, and <i>Applications Information</i> section	6, 12, 14, 16, 19
2	12/18	Updated <i>Benefits and Features</i> , <i>Simplified Block Diagram</i> , <i>Package Information</i> , <i>Functional Diagram</i> , and <i>Reverse-Voltage Protection</i>	1–3, 11, 13
3	2/19	Added MAX16141A to data sheet	1–19

For pricing, delivery, and ordering information, please visit Maxim Integrated's online storefront at <https://www.maximintegrated.com/en/storefront/storefront.html>.

Maxim Integrated cannot assume responsibility for use of any circuitry other than circuitry entirely embodied in a Maxim Integrated product. No circuit patent licenses are implied. Maxim Integrated reserves the right to change the circuitry and specifications without notice at any time. The parametric values (min and max limits) shown in the *Electrical Characteristics* table are guaranteed. Other parametric values quoted in this data sheet are provided for guidance.

Компания «Океан Электроники» предлагает заключение долгосрочных отношений при поставках импортных электронных компонентов на взаимовыгодных условиях!

Наши преимущества:

- Поставка оригинальных импортных электронных компонентов напрямую с производств Америки, Европы и Азии, а так же с крупнейших складов мира;
- Широкая линейка поставок активных и пассивных импортных электронных компонентов (более 30 млн. наименований);
- Поставка сложных, дефицитных, либо снятых с производства позиций;
- Оперативные сроки поставки под заказ (от 5 рабочих дней);
- Экспресс доставка в любую точку России;
- Помощь Конструкторского Отдела и консультации квалифицированных инженеров;
- Техническая поддержка проекта, помощь в подборе аналогов, поставка прототипов;
- Поставка электронных компонентов под контролем ВП;
- Система менеджмента качества сертифицирована по Международному стандарту ISO 9001;
- При необходимости вся продукция военного и аэрокосмического назначения проходит испытания и сертификацию в лаборатории (по согласованию с заказчиком);
- Поставка специализированных компонентов военного и аэрокосмического уровня качества (Xilinx, Altera, Analog Devices, Intersil, Interpoint, Microsemi, Actel, Aeroflex, Peregrine, VPT, Syfer, Eurofarad, Texas Instruments, MS Kennedy, Miteq, Cobham, E2V, MA-COM, Hittite, Mini-Circuits, General Dynamics и др.);

Компания «Океан Электроники» является официальным дистрибьютором и эксклюзивным представителем в России одного из крупнейших производителей разъемов военного и аэрокосмического назначения «JONHON», а так же официальным дистрибьютором и эксклюзивным представителем в России производителя высокотехнологичных и надежных решений для передачи СВЧ сигналов «FORSTAR».



JONHON

«JONHON» (основан в 1970 г.)

Разъемы специального, военного и аэрокосмического назначения:

(Применяются в военной, авиационной, аэрокосмической, морской, железнодорожной, горно- и нефтедобывающей отраслях промышленности)

«FORSTAR» (основан в 1998 г.)

ВЧ соединители, коаксиальные кабели,
кабельные сборки и микроволновые компоненты:

(Применяются в телекоммуникациях гражданского и специального назначения, в средствах связи, РЛС, а так же военной, авиационной и аэрокосмической отраслях промышленности).



Телефон: 8 (812) 309-75-97 (многоканальный)

Факс: 8 (812) 320-03-32

Электронная почта: ocean@oceanchips.ru

Web: <http://oceanchips.ru/>

Адрес: 198099, г. Санкт-Петербург, ул. Калинина, д. 2, корп. 4, лит. А