

LTC6431-20

50Ω 20dB Gain Block IF Amplifier

DESCRIPTION

Demonstration circuit 2077A features the **LTC®6431-20** 50Ω gain block IF amplifier. The LTC6431-20 has a power gain of 20.8dB and it is part of the LTC6431-YY amplifier series.

The DC2077A demo board supports the LTC6431-YY amplifier family. The DC2077A demo board is optimized for a frequency range from 100MHz to 1200MHz. It incorporates a minimum of passive components to configure the

amplifier for various applications. The LTC6431-20 provides 50Ω single-ended input and output impedances so that it can be easily evaluated with most RF test equipment.

Design files for this circuit board are available at <http://www.linear.com/demo>

LT, LT, LTC, LTM, Linear Technology and the Linear logo are registered trademarks of Linear Technology Corporation. All other trademarks are the property of their respective owners.

BLOCK DIAGRAM

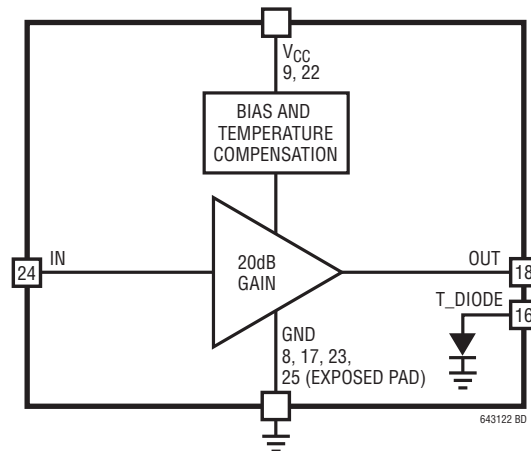

Figure 1. LTC6431-20 Device Block Diagram

DEMO MANUAL DC2077A

PERFORMANCE SUMMARY $T_A = 25^\circ\text{C}$, $V_{CC} = 5\text{V}$

Table 1. Typical Demo Board Performance Summary

SYMBOL	PARAMETER	CONDITIONS	VALUE / UNIT
Power Supply			
V_{CC}	Operating Supply Range	All V_{CC} Pins Plus OUT	4.75V to 5.25V
I_{CC}	Current Consumption	Total Current	95mA

FREQUENCY (MHZ)	POWER GAIN [S21]	OUTPUT THIRD-ORDER INTERCEPT POINT ¹ OIP3	OUTPUT THIRD-ORDER INTERMODULATION ¹ OIM3	SECOND HARMONIC DISTORTION ² HD2	THIRD HARMONIC DISTORTION ² HD3	OUTPUT 1DB COMPRESSION POINT P1DB	NOISE FIGURE ³ NF
100	20.2	47.2	-90.4	-56.8	-96.7	23.2	3.2
200	20.6	48.0	-91.9	-55.6	-92.9	22.4	2.7
240	20.6	47.9	-91.9	-52.5	-106.1	22.0	2.7
300	20.7	47.9	-91.9	-50.5	-83.1	21.8	2.8
400	20.6	46.9	-89.9	-50.4	-77.4	21.7	2.8
500	20.6	45.0	-86.0	-47.8	-72.6	21.8	2.9
600	20.6	42.5	-81.0	-43.7	-64.0	21.7	3.1
700	20.5	39.7	-75.5	-42.1	-60.7	21.4	3.3
800	20.5	38.6	-73.1	-40.6	-63.1	21.4	3.4
900	20.5	37.1	-70.3	-37.1	-60.4	21.1	3.7
1000	20.4	36.0	-68.0	-36.9	-55.1	20.8	3.8
1100	20.3	35.1	-66.2	-35.7	-54.5	20.4	3.9
1200	20.2	34.4	-64.8	-34.4	-53.6	20.3	4.1
Units	dB	dBm	dBc	dBc	dBc	dBm	dB

Notes: All figures are referenced to J1 (Input Port) and J2 (Output Port).

1. Two-tone test conditions: Output power level = +2dBm/tone, tone spacing = 1MHz.

2. Single-tone test conditions: Output power level = +6dBm.

3. Small-signal noise figure.

OPERATION

The demo circuit 2077A is a high linearity, fixed gain amplifier. It is designed for ease of use. Both the input and output are internally matched to 50Ω single-ended source and load impedance. Figure 2 shows the DC2077A's S-parameters.

Figure 4 shows the demo circuit's schematic. The input and output DC blocking capacitors (C1 and C7) are required because this device is internally DC biased for optimal operation. The frequency appropriate choke (L1) and the decoupling capacitors (C3 and C4) provide the proper DC bias to the RF output node. Only a single 5V supply is necessary for the VCC pins on the device.

L2 and C6 are optional parts. These additional components allow for further optimization to lower or wider frequency range applications.

A parallel 62pF (C2) and 348Ω (R1) input network has been added to ensure low frequency stability. Note that the input stability network does degrade performance below 150MHz. Low frequency performance can be improved by increasing the value of capacitor C2.

The T_DIODE Pin (Turret E1) can be forward biased to ground with 1mA of current. The measured voltage will be an indicator of the chip junction temperature (T_J).

OPERATION

Please note that a number of DNC pins are connected on the demo board. These connections are not necessary for normal operation. Failure to float these pins may impair the operation of the device. Table 2 shows the function of each input and output on the board.

Table 2. DC2077A Board I/O Descriptors

CONNECTOR	FUNCTION
J1 (IN)	Single-ended input. Impedance matched to 50Ω. Drive from a 50Ω network analyzer or signal source.
J2 (OUT)	Single-ended output. Impedance matched to 50Ω. Drives a 50Ω network analyzer or spectrum analyzer.
E1 (T_DIODE)	The measured voltage will be an indicator of the chip junction temperature.
E2 (VCC)	Positive supply voltage source.
E3 (GND)	Supply ground.

Additional Information

As with any RF device, minimizing ground inductance is critical. Care should be taken during the board layout when using these exposed pad packages. The maximum number of small-diameter vias should be placed underneath the exposed pad. This will ensure a good RF ground and low thermal impedance. Maximizing the copper ground plane will also improve heat spreading and lower the inductance to ground. It is a good idea to cover the via holes with solder mask on the back side of the PCB to prevent solder from wicking away from the critical PCB to exposed pad interface.

The DC2077A is a wide bandwidth demo board, but it is not intended for operation down to DC. The lower frequency cutoff is limited by on-chip matching elements.

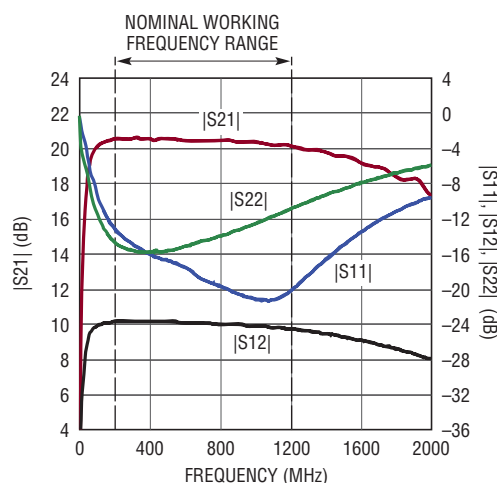

Figure 2. Demo Board S-Parameters

Table 3 shows the LTC643X-YY amplifier series and its associated demo boards. Each demo board lists the typical working frequency range and the input and output impedance of the amplifiers.

Setup Signal Sources and Spectrum Analyzer

The LTC6431-20 is an amplifier with high linearity performance. Therefore, the output intermodulation products are very low. Even using high dynamic range test equipment, third-order intercept (IP3) measurements can drive test setups to their limits. Consequently, accurate measurement of IP3 for a low distortion IC such as the LTC6431-20 requires certain precautions to be observed in the test setup as well as the testing procedure.

Table 3. The LTC643X-YY Amplifier Family and Corresponding Application Demo Boards

DEMO BOARD NUMBER	FREQUENCY RANGE (MHz)	NOTES/APPLICATIONS	BOARD'S IN/OUT IMPEDANCE	AMPLIFIER	AMPLIFIER'S IMPEDANCE
DC1774A-A	50 to 350	Low Frequency	50Ω	LTC6430-15	Differential 100Ω
DC1774A-B	400 to 1000	Mid Frequency	50Ω	LTC6430-15	Differential 100Ω
DC1774A-C	100 to 1200	Wide Frequency	50Ω	LTC6431-15	Single-Ended 50Ω
DC2032A	50 to 1000	Cable Infrastructure	75Ω	LTC6430-15	Differential 100Ω
DC2077A	100 to 1200	Wide Frequency	50Ω	LTC6431-20	Single-Ended 50Ω
DC2153A	700 to 1700	High Frequency	50Ω	LTC6430-15	Differential 100Ω

OPERATION

Setup Signal Sources

Figure 4 shows a proposed IP3 test setup. This setup has low phase noise, good reverse isolation, high dynamic range, sufficient harmonic filtering and wideband impedance matching. The setup is outlined below:

- a. High performance signal generators 1 and 2 (HP8644A) are used. These suggested generators have low harmonic distortion and very low phase noise.
- b. High linearity amplifiers are used to improve the reverse isolation. This prevents crosstalk between the two signal generators and provides higher output power.
- c. A lowpass filter is used to suppress the harmonic content from interfering with the test signal. Note that second order inputs can “mix” with the fundamental frequency to form intermodulation (IM) products of their own. We suggest filtering the harmonics to -50dBc or better.
- d. The signal combiner from Mini-Circuits (ADP-2-9) combines the two isolated input signals. This combiner has a typical isolation of 27dB. For improved VSWR and isolation, the H-9 signal combiner from MA/COM is an alternative which features >40dB isolation and a wider frequency range. Passive devices (e.g. combiners) with magnetic elements can contribute nonlinearity to the signal chain and should be used cautiously.
- e. The attenuator pads on all three ports of the signal combiner will further support isolation of the two input signal sources. They also reduce reflections and promote maximum power transfer with wideband impedance matching.

Setup the Spectrum Analyzer

- a. Adjust the spectrum analyzer for maximum possible resolution of the intermodulation products’ amplitude in dBc. A narrower resolution bandwidth will take a longer time to sweep.
- b. Optimize the dynamic range of the spectrum analyzer by adjusting the input attenuation. First increase the spectrum analyzer’s input attenuation (normally in steps of 5dB or 10dB). If the IM product levels decrease when the input attenuation is increased, then the input power level is too high for the spectrum analyzer to make a valid measurement. Most likely, the spectrum analyzer’s 1st mixer was overloaded and producing its own IM products. If the IM reading holds constant with increased input attenuation, then a sufficient amount of attenuation was present. Adding too much attenuation will bury the intended IM signal in the noise floor. Therefore, select just enough attenuation to achieve a stable and valid measurement.
- c. In order to achieve this valid measurement result, the test system must have lower total distortion than the DUT’s intermodulation. For example, to measure a 48dBm OIP3, the measured intermodulation products will be -92dBc below the -18dBm per tone input level and the test system must have intermodulation products approximately -98dBc or better. For best results, the IM products and noise floor should measure at least -102dBc before connecting the DUT.

QUICK START PROCEDURE

Demo circuit 2077A can be set up to evaluate the performance of the LTC6431-20. Refer to Figure 3 for proper equipment connections and follow the procedure below:

Two-Tone Measurement

Connect all test equipment as suggested in Figure 3.

1. The power labels of VCC 4.75V-5.25V and GND directly correspond to the power supply. Typical current consumption of the LTC6431-20 is about 95mA.
2. Apply two independent signals f1 and f2 from signal generator 1 and signal generator 2 at 240MHz and 241MHz, while setting the amplitude to -18dBm/tone at the demo board input (J1).
3. Monitor the output tone level on the spectrum analyzer. Adjust the signal generator levels such that the output power measures +2dBm/tone at the amplifier output J2, after correcting for external cable losses and attenuations.

4. Change the spectrum analyzer's center frequency and observe the two IM3 tones at 1 MHz below and above the input frequencies. The frequencies of IM3_LOW and IM3_HIGH are 239 MHz and 242 MHz, respectively. The measurement levels should be approximately -92dBc; +48dBm is typical OIP3 performance for the LTC6431-20 at 240MHz.

The OIP3 calculation is:

$$OIP3 = POUT + \Delta IMD3/2$$

where:

POUT is the lower output signal power of the fundamental products.

$\Delta IMD3 = POUT - PIM3$; PIM3 is the higher third-order intermodulation product.

Single-Tone Measurement

5. Continue with Step 4 above, turn off one signal source to measure gain and harmonic distortions.

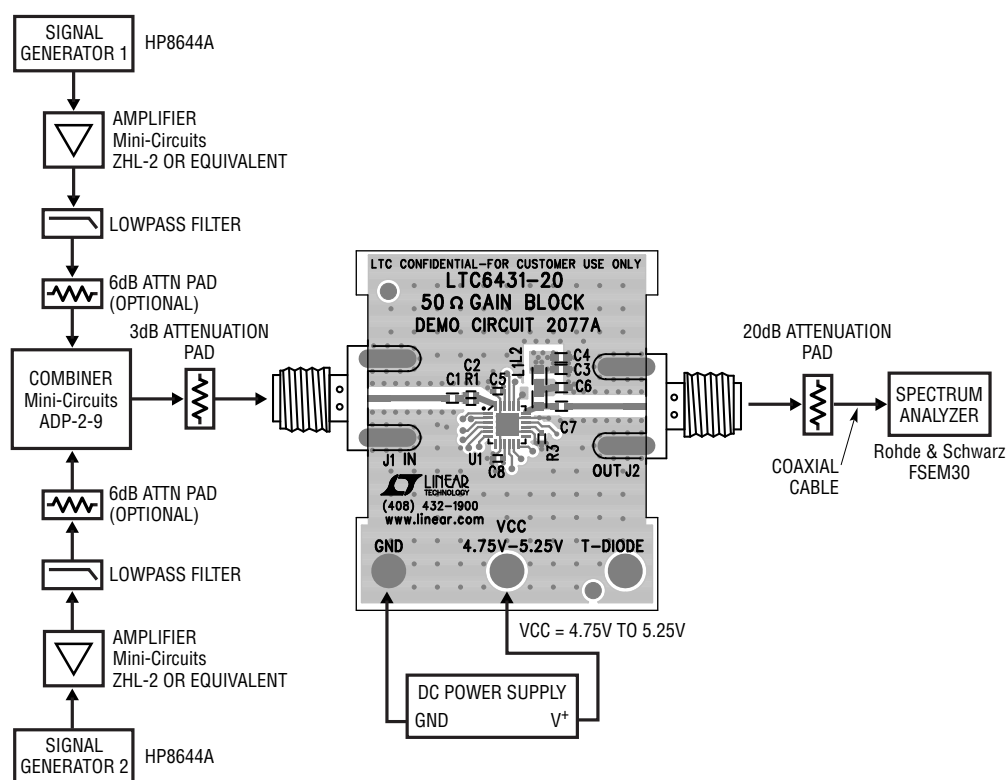

Figure 3. Proper Equipment Setup for IP3 Measurement

DEMO MANUAL DC2077A

PARTS LIST

ITEM	QTY	REFERENCE	PART DESCRIPTION	MANUFACTURER/PART NUMBER
1	3	C1, C3, C7	CAP., X7R, 1000pF, 50V 5%, 0603	AVX, 06035C102JAT2A
2	1	C2	CAP., NPO, 62pF, 25V, 5%, 0402	AVX, 04023A620JAT
3	1	C4	CAP., X5R, 0.1 μ F, 10V, 10%, 0603	AVX, 0603ZD104KAT2A
4	2	C5, C8	CAP., X7R, 1000pF, 50V 5%, 0402	AVX, 04025C102JAT2A
5	1	C6	CAP., OPT, 0603	
6	3	E1-E3	TESTPOINT, TURRET, 0.093"	MILL-MAX, 2501-2-00-80-00-00-07-0
7	2	J1-J2	CONN., SMA 50 Ω EDGE-LAUNCH	E.F.JOHNSON, 142-0701-851
8	1	L1	INDUCTOR, CHIP, 560nH, 5%, 0603LS-1608	COILCRAFT, 0603LS-561XJLB
9	1	L2	RES., CHIP, 0 Ω , 0603	VISHAY, CRCW06030000Z0ED
10	1	R1	RES., CHIP, 348 Ω , 1%, 1/16W, 0402	VISHAY,CRCW0402348RFKED
11	0	R3	RES., OPT, 0402	
12	1	U1	BALANCED AMPLIFIER LTC6431AIUF-20, QFN24UF-4X4	LINEAR TECH., LTC6431AIUF-20

DEMO MANUAL DC2077A

DEMONSTRATION BOARD IMPORTANT NOTICE

Linear Technology Corporation (LTC) provides the enclosed product(s) under the following **AS IS** conditions:

This demonstration board (DEMO BOARD) kit being sold or provided by Linear Technology is intended for use for **ENGINEERING DEVELOPMENT OR EVALUATION PURPOSES ONLY** and is not provided by LTC for commercial use. As such, the DEMO BOARD herein may not be complete in terms of required design-, marketing-, and/or manufacturing-related protective considerations, including but not limited to product safety measures typically found in finished commercial goods. As a prototype, this product does not fall within the scope of the European Union directive on electromagnetic compatibility and therefore may or may not meet the technical requirements of the directive, or other regulations.

If this evaluation kit does not meet the specifications recited in the DEMO BOARD manual the kit may be returned within 30 days from the date of delivery for a full refund. **THE FOREGOING WARRANTY IS THE EXCLUSIVE WARRANTY MADE BY THE SELLER TO BUYER AND IS IN LIEU OF ALL OTHER WARRANTIES, EXPRESSED, IMPLIED, OR STATUTORY, INCLUDING ANY WARRANTY OF MERCHANTABILITY OR FITNESS FOR ANY PARTICULAR PURPOSE. EXCEPT TO THE EXTENT OF THIS INDEMNITY, NEITHER PARTY SHALL BE LIABLE TO THE OTHER FOR ANY INDIRECT, SPECIAL, INCIDENTAL, OR CONSEQUENTIAL DAMAGES.**

The user assumes all responsibility and liability for proper and safe handling of the goods. Further, the user releases LTC from all claims arising from the handling or use of the goods. Due to the open construction of the product, it is the user's responsibility to take any and all appropriate precautions with regard to electrostatic discharge. Also be aware that the products herein may not be regulatory compliant or agency certified (FCC, UL, CE, etc.).

No License is granted under any patent right or other intellectual property whatsoever. **LTC assumes no liability for applications assistance, customer product design, software performance, or infringement of patents or any other intellectual property rights of any kind.**

LTC currently services a variety of customers for products around the world, and therefore this transaction **is not exclusive**.

Please read the DEMO BOARD manual prior to handling the product. Persons handling this product must have electronics training and observe good laboratory practice standards. **Common sense is encouraged.**

This notice contains important safety information about temperatures and voltages. For further safety concerns, please contact a LTC application engineer.

Mailing Address:

Linear Technology
1630 McCarthy Blvd.
Milpitas, CA 95035

Copyright © 2004, Linear Technology Corporation

Компания «Океан Электроники» предлагает заключение долгосрочных отношений при поставках импортных электронных компонентов на взаимовыгодных условиях!

Наши преимущества:

- Поставка оригинальных импортных электронных компонентов напрямую с производств Америки, Европы и Азии, а так же с крупнейших складов мира;
- Широкая линейка поставок активных и пассивных импортных электронных компонентов (более 30 млн. наименований);
- Поставка сложных, дефицитных, либо снятых с производства позиций;
- Оперативные сроки поставки под заказ (от 5 рабочих дней);
- Экспресс доставка в любую точку России;
- Помощь Конструкторского Отдела и консультации квалифицированных инженеров;
- Техническая поддержка проекта, помощь в подборе аналогов, поставка прототипов;
- Поставка электронных компонентов под контролем ВП;
- Система менеджмента качества сертифицирована по Международному стандарту ISO 9001;
- При необходимости вся продукция военного и аэрокосмического назначения проходит испытания и сертификацию в лаборатории (по согласованию с заказчиком);
- Поставка специализированных компонентов военного и аэрокосмического уровня качества (Xilinx, Altera, Analog Devices, Intersil, Interpoint, Microsemi, Actel, Aeroflex, Peregrine, VPT, Syfer, Eurofarad, Texas Instruments, MS Kennedy, Miteq, Cobham, E2V, MA-COM, Hittite, Mini-Circuits, General Dynamics и др.);

Компания «Океан Электроники» является официальным дистрибьютором и эксклюзивным представителем в России одного из крупнейших производителей разъемов военного и аэрокосмического назначения «JONHON», а так же официальным дистрибьютором и эксклюзивным представителем в России производителя высокотехнологичных и надежных решений для передачи СВЧ сигналов «FORSTAR».



JONHON

«JONHON» (основан в 1970 г.)

Разъемы специального, военного и аэрокосмического назначения:

(Применяются в военной, авиационной, аэрокосмической, морской, железнодорожной, горно- и нефтедобывающей отраслях промышленности)

«FORSTAR» (основан в 1998 г.)

ВЧ соединители, коаксиальные кабели,
кабельные сборки и микроволновые компоненты:

(Применяются в телекоммуникациях гражданского и специального назначения, в средствах связи, РЛС, а так же военной, авиационной и аэрокосмической отраслях промышленности).



Телефон: 8 (812) 309-75-97 (многоканальный)

Факс: 8 (812) 320-03-32

Электронная почта: ocean@oceanchips.ru

Web: <http://oceanchips.ru/>

Адрес: 198099, г. Санкт-Петербург, ул. Калинина, д. 2, корп. 4, лит. А